

# N625P210460W



# N625P210461W

Product manual

Gebrauchsanweisung

Manuel du produit

Manual del producto

Manuale del prodotto

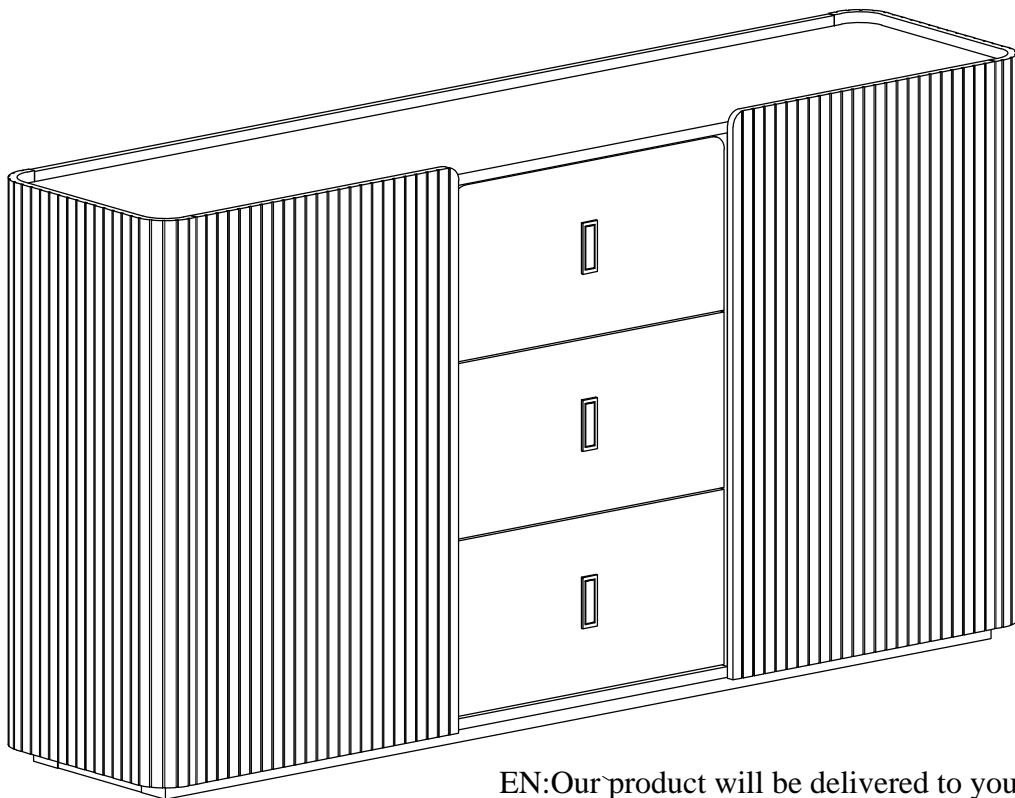

EN:Our product will be delivered to you in 2 packages. The delivery times of these 2 packages may differ, please be patient and thank you for your understanding

FR:Notre produit vous sera livré en 2 colis. Les délais de livraison de ces 2 colis peuvent différer, soyez patient et merci de votre compréhension.

DE:Unser Produkt wird Ihnen in 2 Paketen geliefert. Die Lieferzeiten dieser 2 Pakete können abweichen, bitte haben Sie etwas Geduld und vielen Dank für Ihr Verständnis

IT:I nostri prodotti vengono trasportati in due pacchetti. I tempi di consegna dei due pacchetti sono diversi: abbiate pazienza e vi ringrazio per la vostra comprensione.

ES:Nuestro producto se entrega en dos paquetes. El tiempo de entrega de estos dos paquetes es diferente. Por favor, sea paciente. Gracias por su comprensión.

Importeur	Decobus Handel GmbH
Adresse	Innungsstraße 9, 21244 Buchholz, Deutschland
URL	<a href="https://www.decobusgroup.de">https://www.decobusgroup.de</a>
Hersteller	SHANDONG CHANGHENG WOOD CO., LTD
Adresse	ANJIAVILLAGE, GUCHENG SUB-DISTRICT, SHOUGUANG SHANDONG CHINA
Email/URL	1327411424@qq.com
EC REP	Decobus Handel GmbH Innungsstraße 9, 21244 Buchholz, Deutschland <a href="https://www.decobusgroup.de">https://www.decobusgroup.de</a>



2PERS

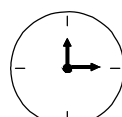

45 MIN

Tool Required Not Provided

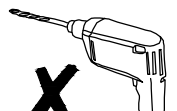
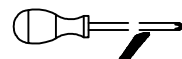
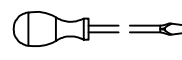



[DE]

**Warnung:** Lesen Sie diese Anleitung vor dem Zusammenbau bitte vollständig durch. Überprüfen Sie, ob Sie alle auf den Seiten aufgeführten Komponenten und Werkzeuge haben. Bewahren Sie die Anleitung zum späteren Nachschlagen auf. Teile des Zusammenbaus lassen sich mit 2 Personen leichter durchführen. Suchen Sie bei Bedarf professionelle Hilfe.

**Warnung:** Legen Sie alle Teile auf eine ebene Fläche. Legen Sie eine weiche Decke oder Ähnliches darunter, um sie vor Kratzern oder Flecken zu schützen. Vermeiden Sie es, Komponenten über den Boden zu ziehen oder zu schieben.

**Warnung:** Überprüfen Sie regelmäßig alle Beschläge und Befestigungen, um sicherzustellen, dass sie sicher sind und um Unfälle zu vermeiden. Wenn Teile fehlen, kaputt, beschädigt oder abgenutzt sind, verwenden Sie das Produkt nicht weiter, bis es mit vom Hersteller autorisierten Teilen repariert wurde.

**Warnung:** Lassen Sie Kinder nicht auf die Möbel klettern, da dies zum Umkippen und zu schweren Verletzungen führen kann. Bauen Sie die Möbel außerhalb der Reichweite von Kindern zusammen.

**Warnung:** Stellen Sie die Möbel nicht in die Nähe von Feuerquellen oder heißen Gegenständen, um Brandgefahr zu vermeiden.

**Warnung:** Reinigen Sie die Möbel mit einem feuchten Tuch oder Alkohol. Verwenden Sie keine Reinigungsmittel mit ätzenden Chemikalien.

**Warnung:** Dieses Produkt ist mit einer Kippschutzvorrichtung ausgestattet. Bitte installieren Sie diese Vorrichtung unbedingt, um unnötige Verletzungen durch Umkippen zu vermeiden.

[EN]

**Warning:** Please read these instructions fully before starting assembly. Check you have all the components and tools listed on pages. Keep the instructions for later reference. Parts of the assembly will be easier with 2 people. Seek professional assistance if necessary.

**Warning:** Please place all parts on a flat surface. Place a soft blanket or similar underneath to protect against scratches or stains. Avoid dragging or sliding components across the floor.

**Warning:** Regularly check all fittings and fastenings to ensure they are secure and to prevent accidents. If any parts are missing, broken, damaged, or worn, discontinue use of the product until repairs have been made using factory authorized parts.

**Warning:** Do not allow children to climb on the furniture as this may result in tipping and serious personal injury. Assemble the furniture away from the reach of children.

**Warning:** Do not place furniture close to fire sources or high-temperature objects to avoid the risk of fire. Do not place furniture in damp environments to prevent material damage.

**Warning:** Clean furniture with a damp cloth or alcohol, avoid using cleaning agents containing corrosive chemicals.

**Warning:** This product is equipped with an anti-tilt device. Please be sure to install this device to prevent unnecessary injuries caused by tipping.

[FR]

**Avertissement :** Veuillez lire attentivement ces instructions avant de commencer l'assemblage. Vérifiez que vous disposez de tous les composants et outils répertoriés sur les pages. Conservez les instructions pour référence ultérieure. Certaines parties de l'assemblage seront plus faciles à 2 personnes. Demandez l'aide d'un professionnel si nécessaire.

**Avertissement :** Veuillez placer toutes les pièces sur une surface plane. Placez une couverture douce ou similaire en dessous pour les protéger des rayures ou des taches. Évitez de faire glisser les composants sur le sol.

**Avertissement :** Vérifiez régulièrement tous les raccords et fixations pour vous assurer qu'ils sont bien fixés et

pour éviter les accidents. Si des pièces manquent, sont cassées, endommagées ou usées, cessez d'utiliser le produit jusqu'à ce que des réparations aient été effectuées à l'aide de pièces autorisées par l'usine.

**Avertissement** : Ne laissez pas les enfants grimper sur les meubles car cela pourrait entraîner un basculement et des blessures graves. Assemblez les meubles hors de portée des enfants.

**Avertissement** : Ne placez pas les meubles à proximité de sources de feu ou d'objets à haute température pour éviter tout risque d'incendie.

**Avertissement** : Nettoyez les meubles avec un chiffon humide ou de l'alcool, évitez d'utiliser des produits de nettoyage contenant des produits chimiques corrosifs.

**Avertissement** : Ce produit est équipé d'un dispositif anti-basculement. Assurez-vous d'installer ce dispositif pour éviter les blessures inutiles causées par un basculement.

[IT]

**Attenzione**: leggere attentamente queste istruzioni prima di iniziare il montaggio. Verificare di avere tutti i componenti e gli strumenti elencati nelle pagine. Conservare le istruzioni per riferimento futuro. Alcune parti del montaggio saranno più facili con 2 persone. Se necessario, chiedere assistenza professionale.

**Attenzione**: posizionare tutte le parti su una superficie piana. Posizionare una coperta morbida o simile sotto per proteggere da graffi o macchie. Evitare di trascinare o far scivolare i componenti sul pavimento.

**Attenzione**: controllare regolarmente tutti i raccordi e i dispositivi di fissaggio per assicurarsi che siano sicuri e per prevenire incidenti. Se alcune parti sono mancanti, rotte, danneggiate o usurate, interrompere l'uso del prodotto fino a quando non siano state eseguite le riparazioni utilizzando parti autorizzate dalla fabbrica.

**Attenzione**: non consentire ai bambini di arrampicarsi sui mobili poiché ciò potrebbe causare ribaltamenti e gravi lesioni personali. Montare i mobili lontano dalla portata dei bambini.

**Attenzione**: non posizionare i mobili vicino a fonti di fuoco o oggetti ad alta temperatura per evitare il rischio di incendio

**Attenzione**: pulire i mobili con un panno umido o alcol, evitare di utilizzare detersivi contenenti sostanze chimiche corrosive.

**Attenzione**: questo prodotto è dotato di un dispositivo antiribaltamento. Assicurarsi di installare questo dispositivo per prevenire lesioni inutili causate dal ribaltamento.

[ES]

**Advertencia**: Lea estas instrucciones completamente antes de comenzar el montaje. Compruebe que tiene todos los componentes y herramientas que se enumeran en las páginas. Conserve las instrucciones para consultarlas más adelante. El montaje de algunas partes será más sencillo con 2 personas. Busque ayuda profesional si es necesario.

**Advertencia**: Coloque todas las piezas sobre una superficie plana. Coloque una manta suave o algo similar debajo para protegerlas de rayones o manchas. Evite arrastrar o deslizar los componentes por el piso.

**Advertencia**: Verifique regularmente todos los accesorios y fijaciones para asegurarse de que estén seguros y evitar accidentes. Si falta alguna pieza, está rota, dañada o desgastada, deje de usar el producto hasta que se hayan realizado las reparaciones con piezas autorizadas de fábrica.

**Advertencia**: No permita que los niños se suban a los muebles, ya que esto puede provocar que se vuelquen y lesiones personales graves. Monte los muebles fuera del alcance de los niños.

**Advertencia**: No coloque los muebles cerca de fuentes de fuego u objetos de alta temperatura para evitar el riesgo de incendio.

**Advertencia**: Limpie los muebles con un paño húmedo o alcohol, evite usar agentes de limpieza que contengan químicos corrosivos.

**Advertencia**: Este producto está equipado con un dispositivo antivuelco. Asegúrese de instalar este dispositivo para evitar lesiones innecesarias causadas por vuelcos.

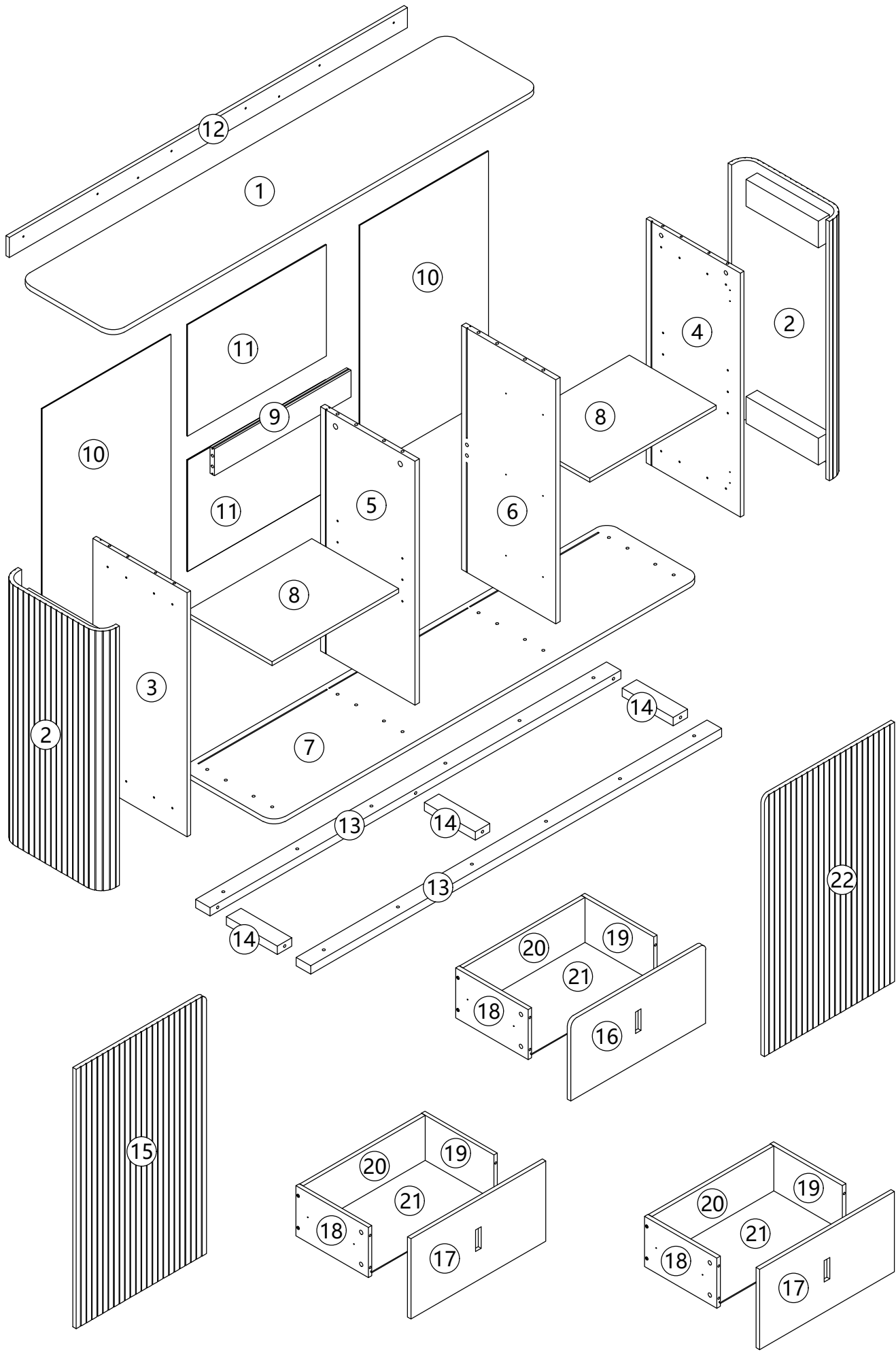

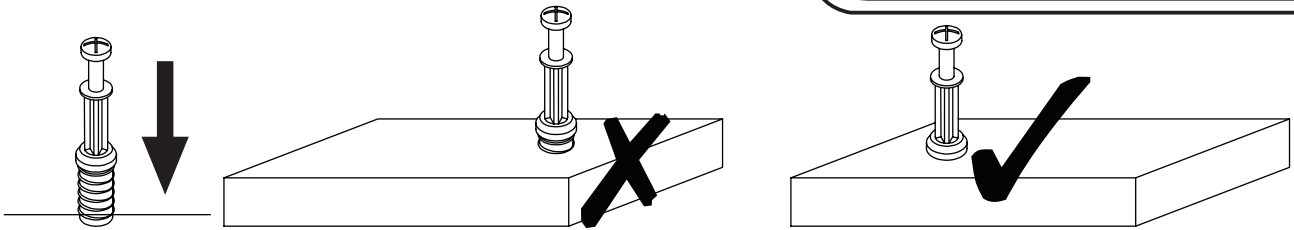

**EN\_QUICKFIT:** Tighten quickfit until shoulder is flush with panel. Do not overtighten or undertighten.

**FR\_RACCORD RAPIDE:** Faites serrer le raccord rapide jusqu'à ce que l'épaulement soit parfaitement encastré dans le panneau. Il ne faut ni trop serrer ni insuffisamment serrer.

**ES\_QUICKFIT:** Apriete quickfit hasta que el hombro se descargue con el panel. NO lo sobreapriete ni lo apriete poco.

**DE\_QUICKFIT:** Ziehen Sie den Quickfit fest, bis die Schulter mit der Platte bündig ist. Bitte nicht zu fest oder zu schwach anziehen.

**IT\_MONTAGGIO RAPIDO:** Stringere il montaggio rapido fino a quando la spalla è a filo con il pannello, non stringere troppo o troppo poco.

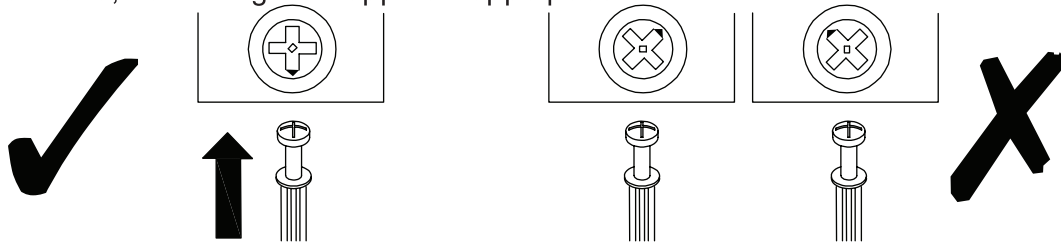

**EN\_CAM LOCK:** When fitting cam lock, ensure starting position is correct before you insert connecting quickfit.

**FR\_SERRURE BATTEUSE:** Avant d'insérer la serrure batteuse, veillez à la bonne orientation avant d'insérer le raccord rapide.

**ES\_CIERRE DE LA CÁMARA:** Cuando instale el cierre de la cámara, asegúrese de que la posición de inicio es correcta antes de que inserte el quickfit conector.

**DE\_CAM-LOCK:** Achten Sie bei der Montage des Cam-Locks auf die richtige Ausgangsposition, bevor Sie den Quickfit einsetzen.

**IT\_BLOCCAGGIO A CAMMA:** Quando si monta il bloccaggio a camma, assicurarsi che la posizione iniziale sia corretta prima di inserire il montaggio rapido di collegamento.

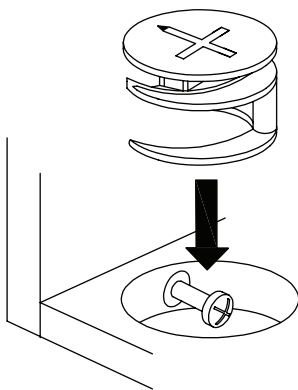

**EN\_Quickfit head** should be in the centre of the cam lock when the two panels are joined.

Cam lock should be inserted before quickfit.

**FR\_**Lorsque les deux panneaux sont assemblés, la tête du raccord rapide doit reposer au centre de la serrure batteuse. Il faut insérer la serrure batteuse avant le raccord rapide.

**ES\_**El cabezal del quickfit debe estar en el centro del cierre de la cámara cuando se unan los dos paneles.

Se debe insertar el cierre de la cámara antes que el quickfit.

**DE\_**Der Quickfit-Kopf sollte sich in der Mitte des Cam-Locks befinden, wenn die beiden Platten zusammengefügt sind. Der Cam-Lock sollte vor dem Quickfit eingesetzt werden.

**IT\_**La testa del montaggio rapido deve trovarsi al centro del bloccaggio a camma quando i due pannelli sono uniti.

Il Bloccaggio a Camma deve essere inserito prima del montaggio rapido.

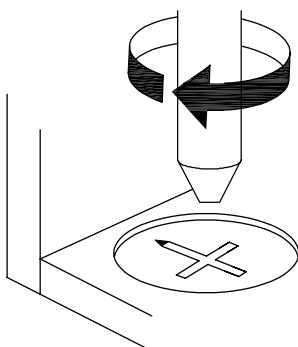

**EN\_**Turn cam lock clockwise to tighten.

**FR\_**Faites tourner la serrure batteuse dans le sens des aiguilles d'une montre pour la resserrer.

**ES\_**Gire el cierre de la cámara en sentido horario para apretarlo.

**DE\_**Drehen Sie den Cam-Lock im Uhrzeigersinn, um ihn festzuziehen.

**IT\_**Ruotare il bloccaggio a camma in senso orario per stringere.

**EN** It may be necessary to adjust the hinges so that the doors align. Use the instructions below as a guide.

**FR** Il est parfois nécessaire d'ajuster les charnières pour un meilleur alignement des portes. Servez-vous des instructions ci-dessous comme guide.

**ES** Puede que sea necesario ajustar los quicios de forma que se alineen las puertas. Use las instrucciones que aparecen debajo como guía.

**DE** Möglicherweise müssen Sie die Scharniere so einstellen, dass die Türen ausgerichtet sind. Verwenden Sie die nachstehenden Anweisungen als Leitfaden.

**IT** Potrebbe essere necessario regolare le cerniere in modo che le porte siano allineate. Per fare ciò attenersi alle istruzioni sottostanti.

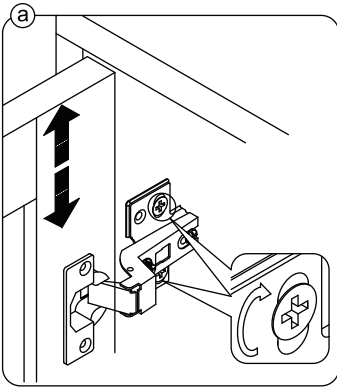

**EN** To adjust the door vertically loosen the screw as shown and move up and down as needed.

**FR** Si vous souhaitez régler la porte **verticalement**, desserrez la vis comme indiqué et déplacez la porte de haut en bas selon les besoins.

**ES** Para ajustar la puerta **verticalmente** afloje el tornillo tal y como se muestra y muévelo hacia arriba o hacia abajo según sea necesario.

**DE** Um die Tür **vertikal** auszurichten, lösen Sie die Schraube wie abgebildet und bewegen Sie sie nach Bedarf nach oben oder nach unten.

**IT** Per allineare la porta **verticalmente** allentare la vite come mostrato e spostarla in alto o in basso secondo necessità.

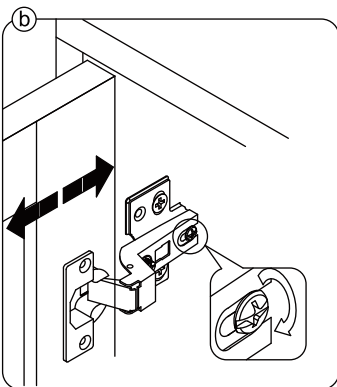

**EN** To adjust the gap from the door to the main frame turn the screw clockwise or anti-clockwise as needed.

**FR** Si vous souhaitez ajuster l'**écart** entre la porte et le cadre principal, tournez la vis dans le sens des aiguilles d'une montre ou dans le sens inverse, si nécessaire.

**ES** Para ajustar el **espacio** desde la puerta al marco principal, gire el tornillo en sentido horario o antihorario, según se necesite.

**DE** Um den **Abstand** von der Tür zum Hauptrahmen auszurichten, drehen Sie die Schraube je nach Bedarf im oder gegen den Uhrzeigersinn.

**IT** Per regolare lo **spazio** tra la porta e il telaio principale, avvitare o svitare la vite secondo necessità.

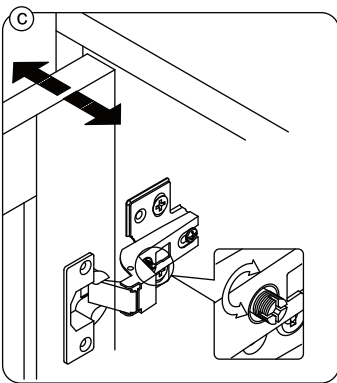

**EN** To adjust the door laterally adjust the screw as shown by turning clockwise or anti-clockwise.

**FR** Si vous souhaitez ajuster la porte **latéralement**, ajustez la vis comme indiqué en tournant dans le sens des aiguilles d'une montre ou dans le sens inverse des aiguilles d'une montre.

**ES** Para ajustar la puerta **lateralmente** ajuste el tornillo tal y como se muestra girándolo en sentido horario y antihorario.

**DE** Um die Tür **seitlich** auszurichten, stellen Sie bitte die Schraube wie abgebildet durch Drehen im oder gegen den Uhrzeigersinn ein.

**IT** Per allineare la porta **lateralmente** regolare la vite come mostrato, avvitarandola o svitarandola.

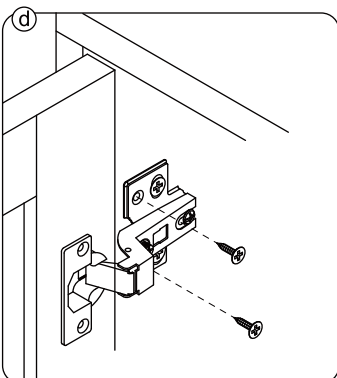

**EN** Please fix other screws

**FR** Merci de serrer les autres vis.

**ES** Fije los demás tornillos

**DE** Befestigen Sie bitte die anderen Schrauben

**IT** Fissare le altre viti

**EN\_NOTE:** Pull inner and outer drawer runners apart before fixing them to panels.

**FR\_REMARQUE:** Avant de fixer les glissières de tiroir aux panneaux, tirez vers l'extérieur et poussez vers l'intérieur de chacun des tiroirs.

**ES\_NOTA:** retire los rieles interiores y exteriores antes de fijarlos a los paneles.

**PT\_NOTA:** Separar as corredeças das gavetas interiores e exteriores antes de fixar para os painéis.

**DE\_HINWEIS:** Ziehen Sie die inneren und äußeren Schubladenführung auseinander, bevor Sie sie an den Platten befestigen.

**IT\_NOTA:** Separare le guide interne ed esterne del cassetto prima di fissarle ai pannelli.

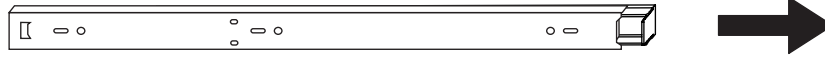

**EN\_Slide** drawer runners apart until the drawer lock can be seen, as shown.

**FR\_Les** glissières de tiroir doivent être ouvertes jusqu'à ce que la serrure du tiroir soit visible, comme indiqué.

**ES\_Deslice** a un lado los rieles del cajón hasta que se pueda ver el cierre del armario, tal y como se muestra.

**PT\_Deslizam-se** as gavetas até se poder ver o fecho da gaveta, como se mostra.

**DE\_Schieben** Sie die Schubladenführungen auseinander, bis das Schubladenschloss sichtbar ist, gemäß der Abbildung.

**IT\_Far** scorrere le guide del cassetto fino a quando non sia visibile il blocco di scorrimento, come mostrato.

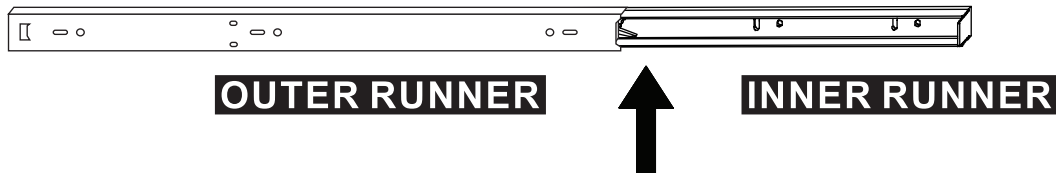

**EN\_Press** and hold the drawer runner lock and then continue to slide drawer runners apart, as shown.

**FR\_En** appuyant et en maintenant le verrouillage des glissières de tiroir, vous pouvez continuer à les écarter l'une de l'autre, comme indiqué.

**ES\_Mantenga** presionado el cierre del riel del cajón y después continúe deslizando a un lado los rieles de los cajones, tal y como se muestra.

**PT\_Manter** pressionado o fecho de gaveta e depois continuar a deslizar as corredeças da gaveta, como mostrado.

**DE\_Drücken** und halten Sie die Verriegelung der Schubladenführung und schieben Sie die Schubladenführungen wie abgebildet weiter auseinander.

**IT\_Tenere** premuto il blocco di scorrimento e quindi continuare a far scorrere la guida, come mostrato.

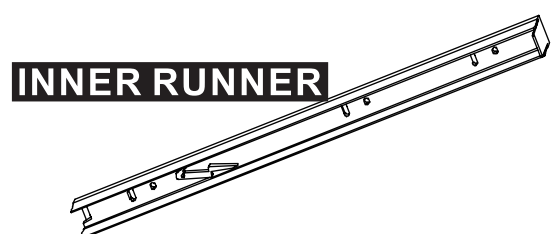
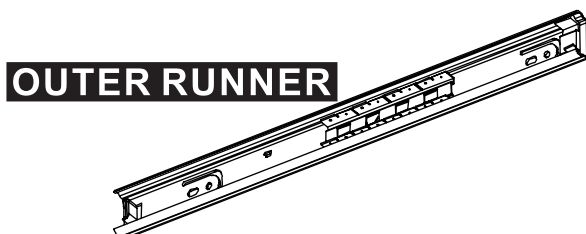
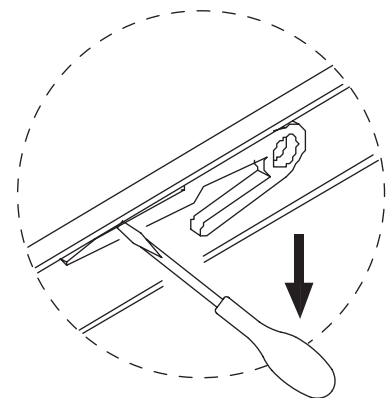

**EN\_Your** inner and outer drawer runners are ready to be fixed to panels.

**FR\_Il** est possible, à présent, de fixer les glissières intérieures et extérieures de vos tiroirs sur des panneaux.

**ES\_Los** rieles interiores y exteriores del cajón están listos para fijarse a los paneles.

**PT\_As** corredeças das gavetas interiores e exteriores estão prontas para serem fixadas nos painéis.

**DE\_Ihre** inneren und äußeren Schubladenführungen sind bereit, an den Platten befestigt zu werden.

**IT\_Le** guide interne ed esterne sono pronte per essere fissate ai pannelli.

# N625P210460W

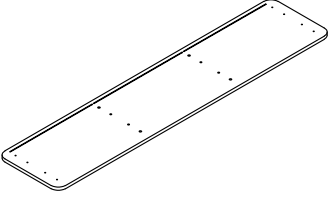
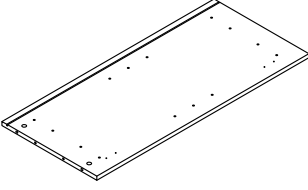
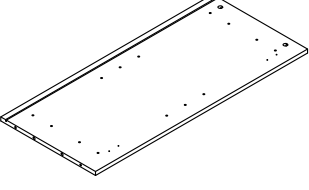
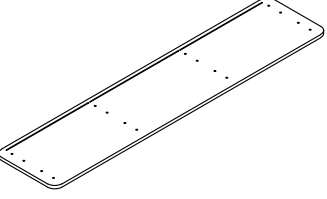
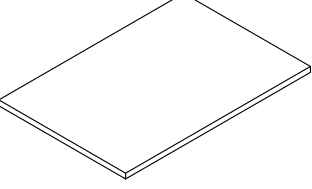
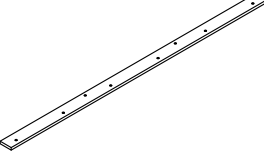
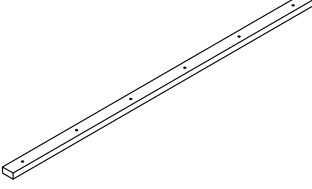
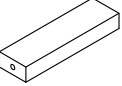
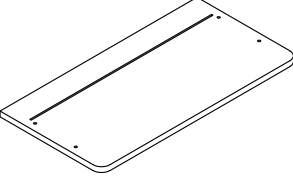
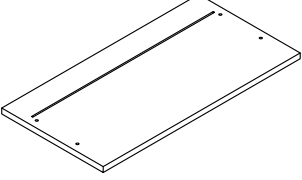
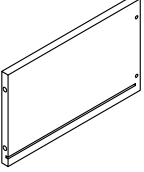
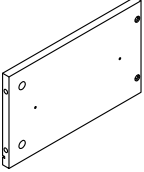
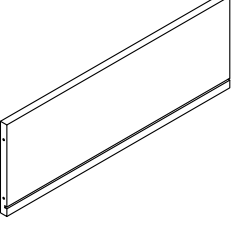
1  1PC	3  1PC	4  1PC	7  1PC
8  2PCS	12  1PC	13  2PCS	14  3PCS
16  1PC	17  2PCS	18  3PCS	19  3PCS
20  3PCS			

# N625P210461W

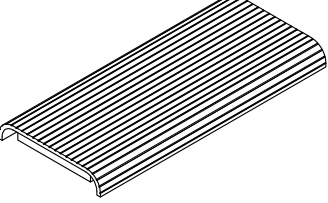
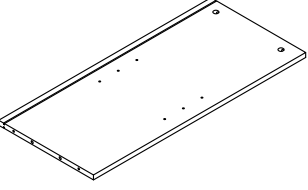
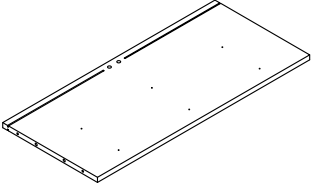
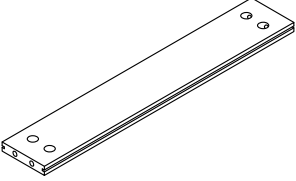
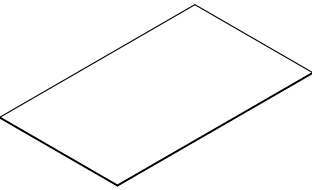
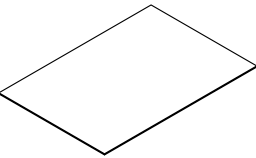
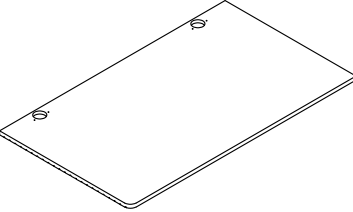
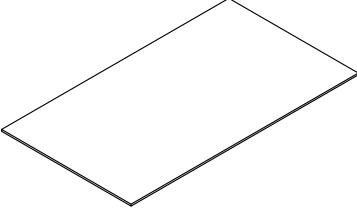
2  2PCS	5  1PC	6  1PC	9  1PC
10  2PCS	11  2PCS	15  1PC	21  3PCS



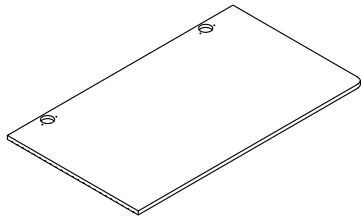

1PC

# Hardware N625P210461W

**A**

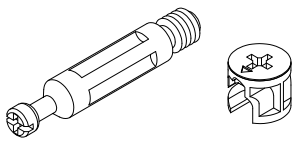

A1

A2

8STES

**B**

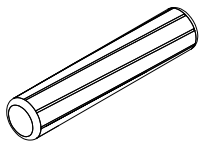

8 x 40MM

14PCS

**C**



3.5 x 12MM

72PCS

**D**

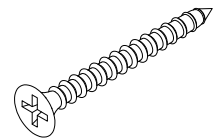

3.5 x 30MM

12PCS

**E**

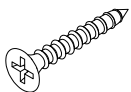

4 x 25MM

8PCS

**F**

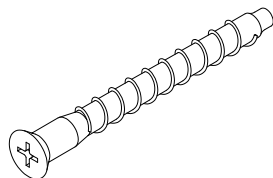

5 x 50MM

8PCS

**G**



8PCS

**H**

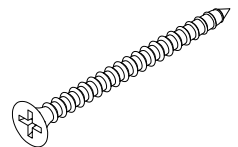

4 x 45MM

16PCS

**J**

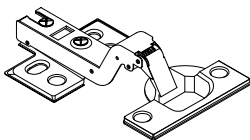

4PCS

**K**



K1

K2

16STES

**L**

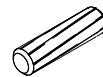

6 x 30MM

8PCS

**M**

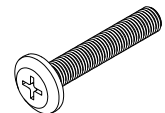

M6 x 35MM

12PCS

**N**

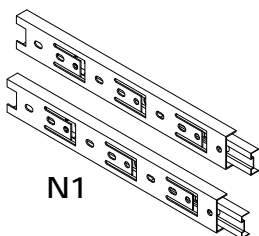

N1

N2

3STES

**P**



24PCS

**Q**

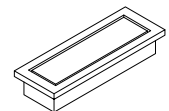

3PCS

**R**

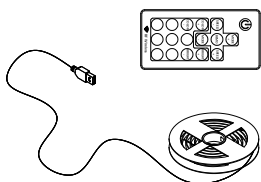

1PC

**S**

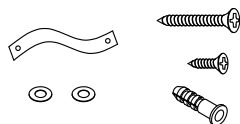

2STES

**T**

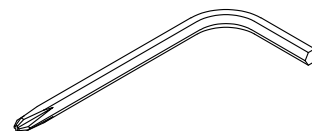

1PC

1

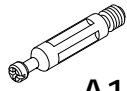

A1 x 4



K1 x 4



L x 8

6 x 30MM

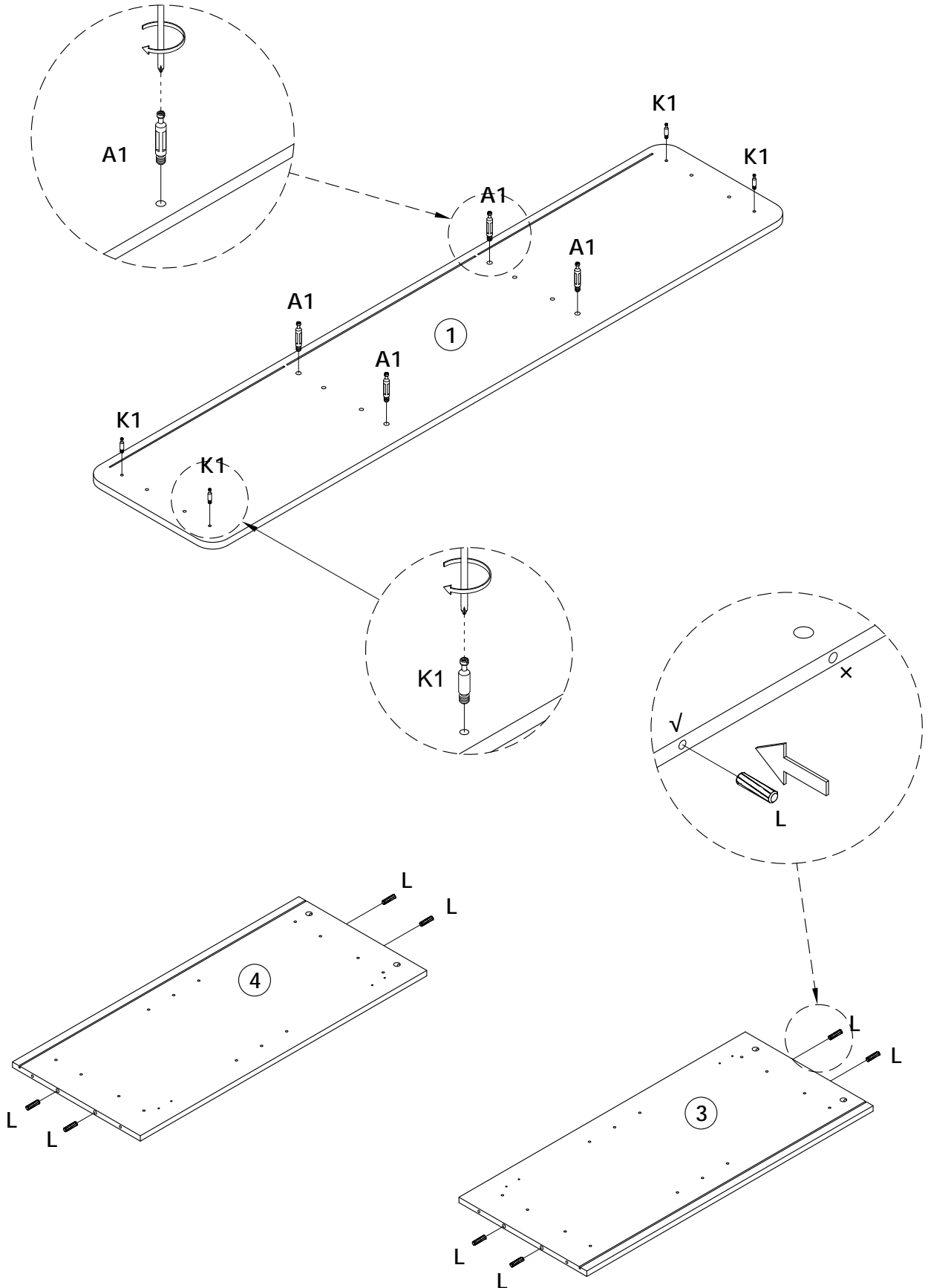

2

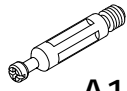

A1 x 4

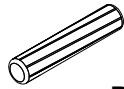

B x 8



3.5 x 12MM

C x 12

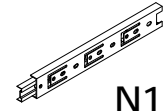

N1 x 6

8 x 40MM

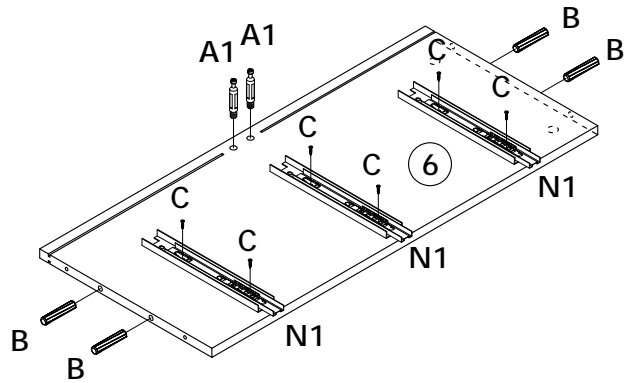
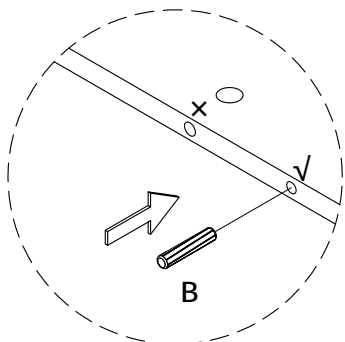
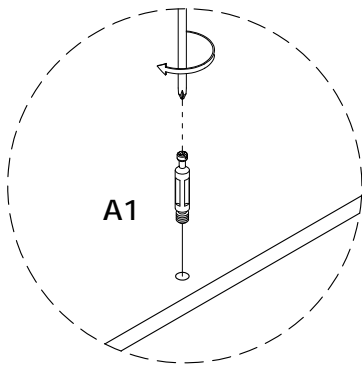
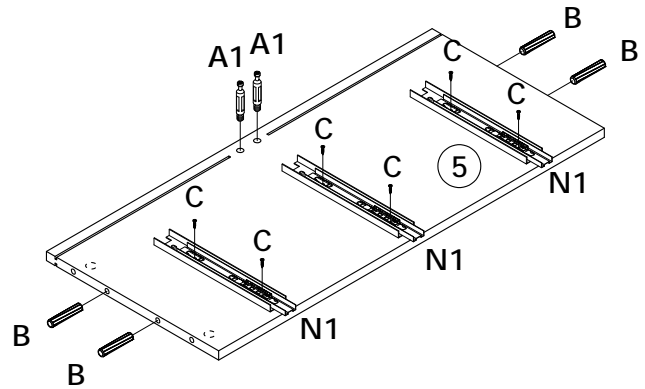
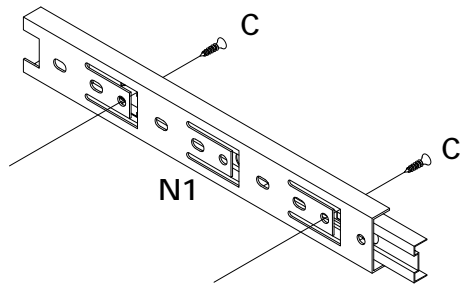
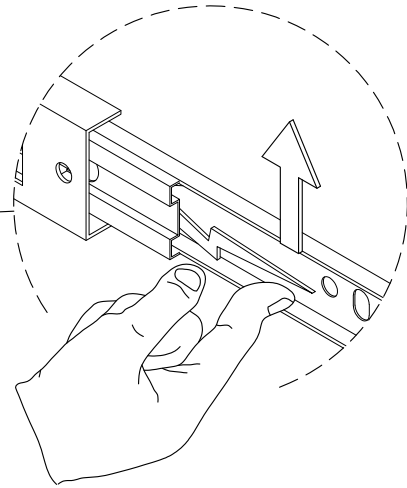
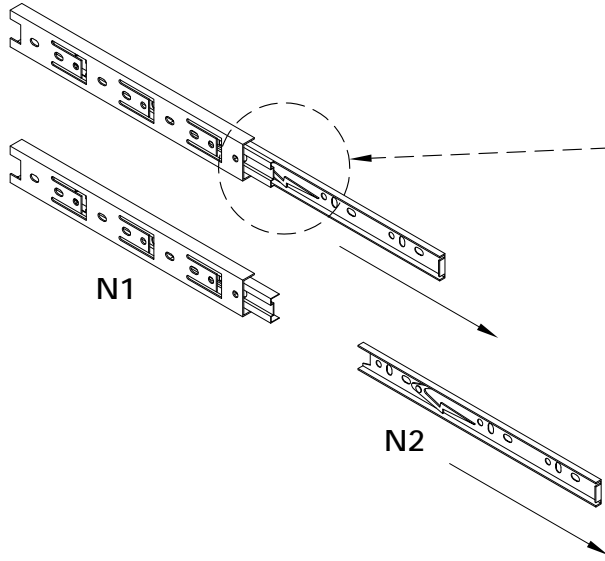

3



A2 x 8

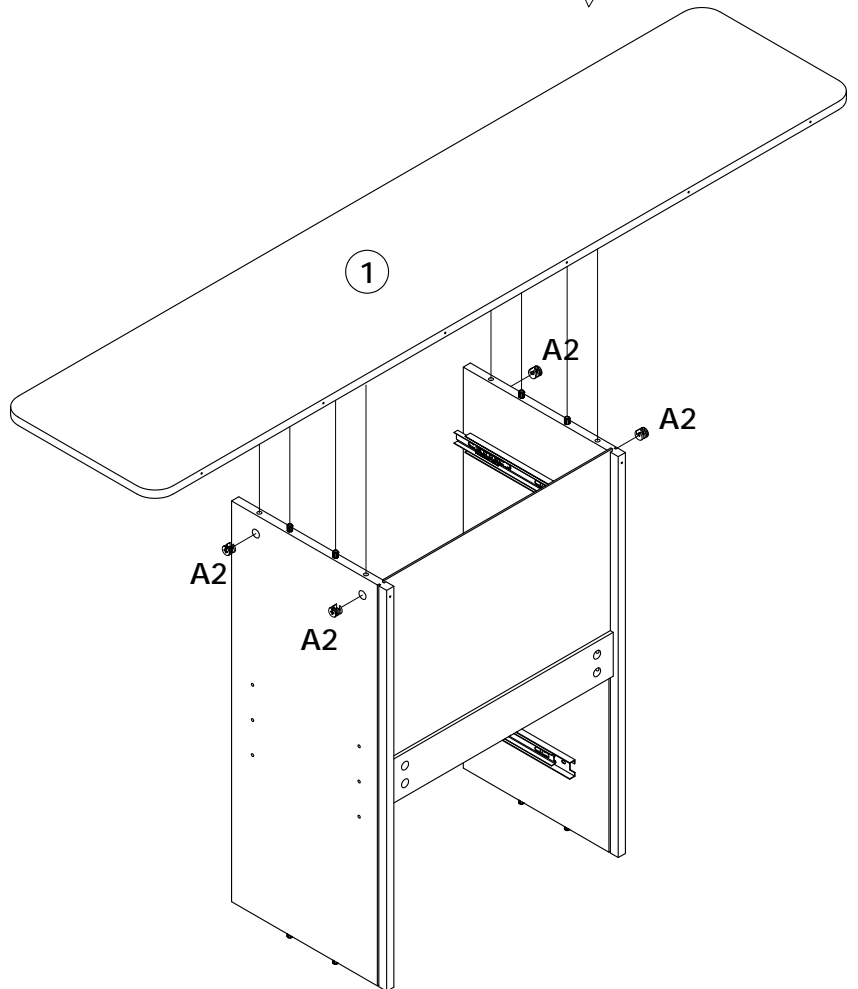
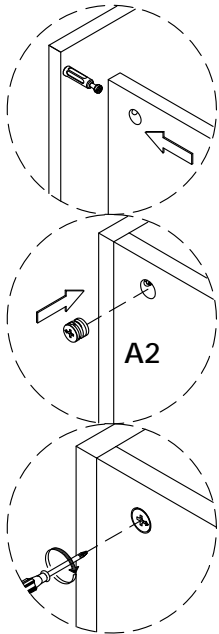
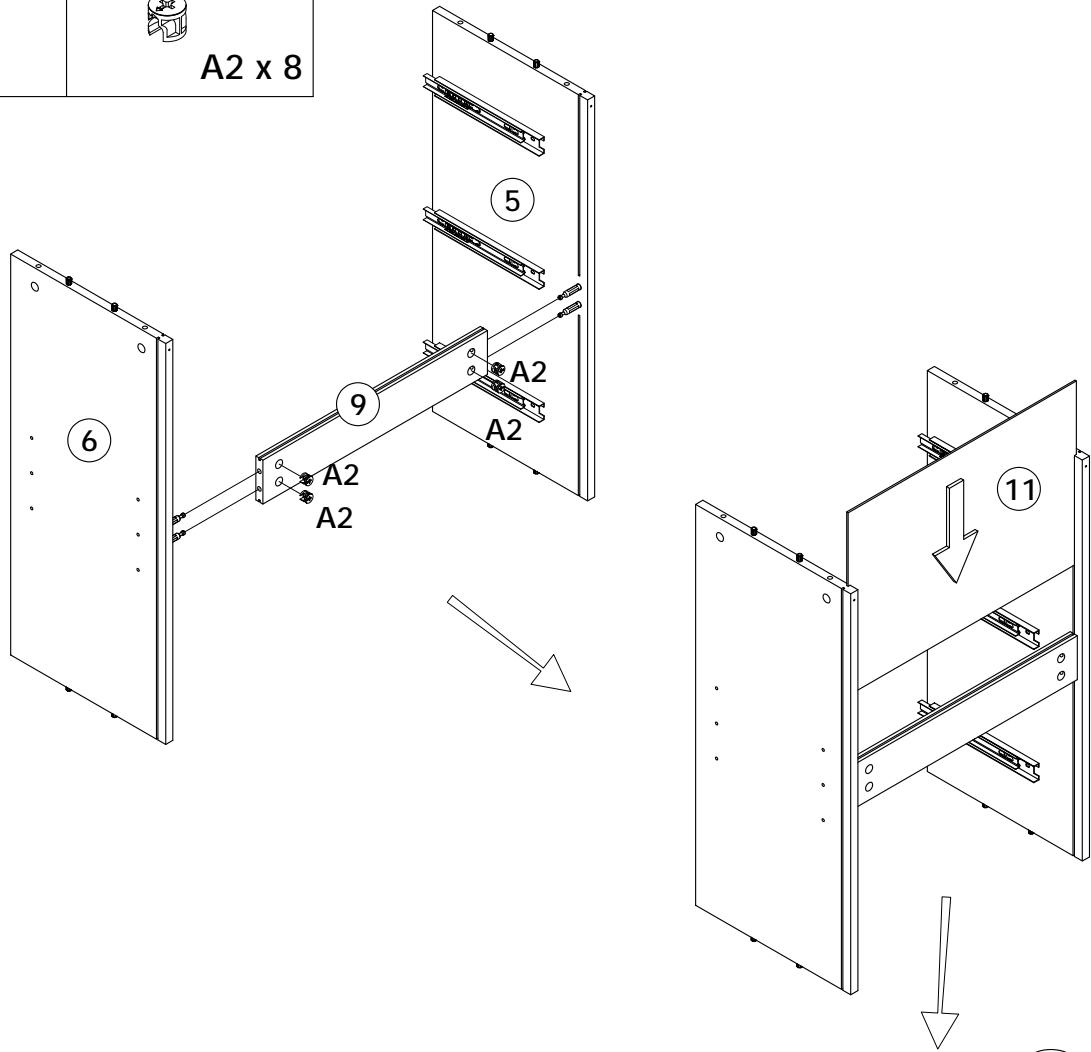

4

7 x 50MM  
F x 8

K2 x 4

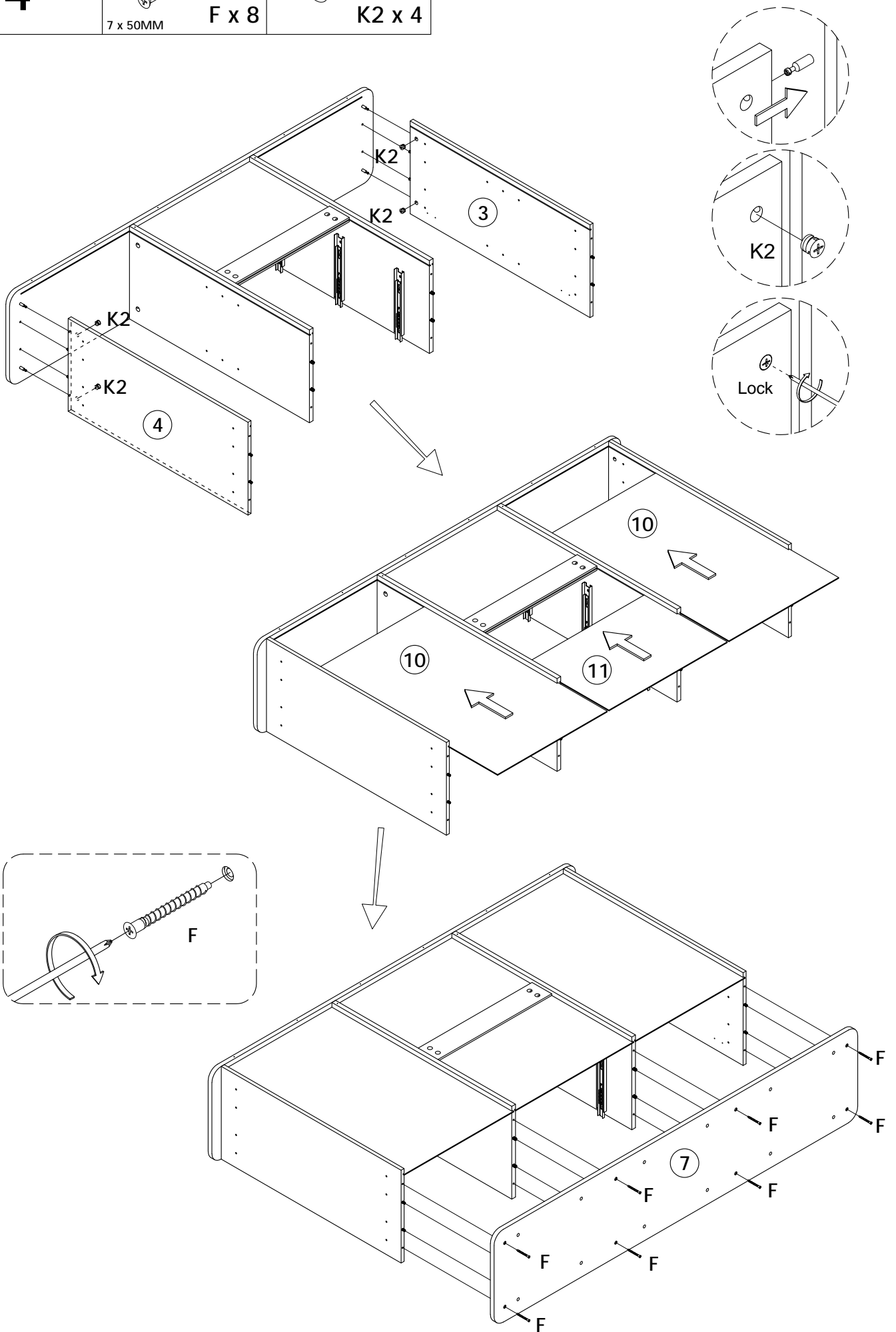

5

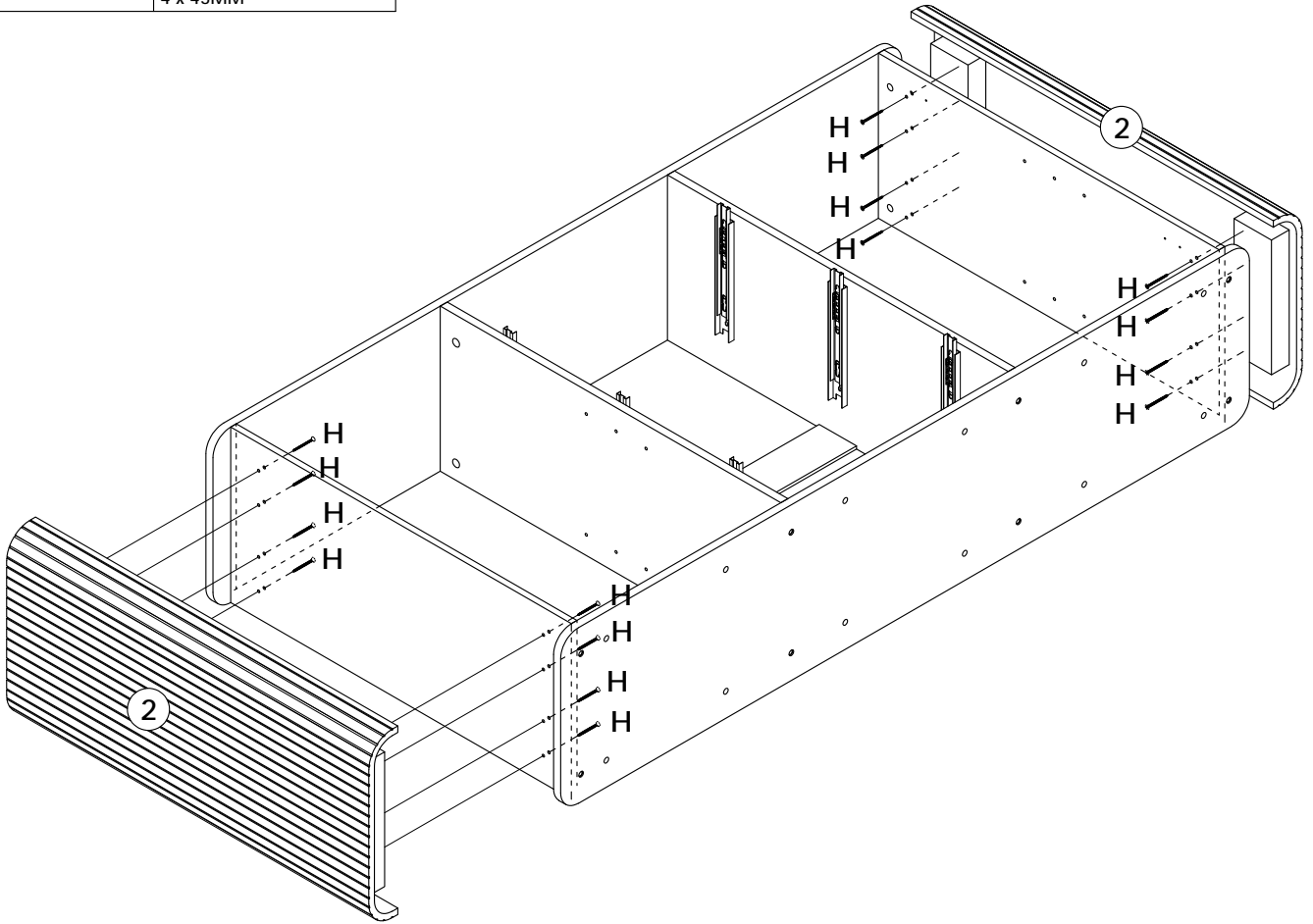
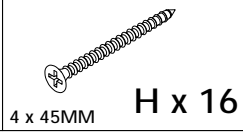

6

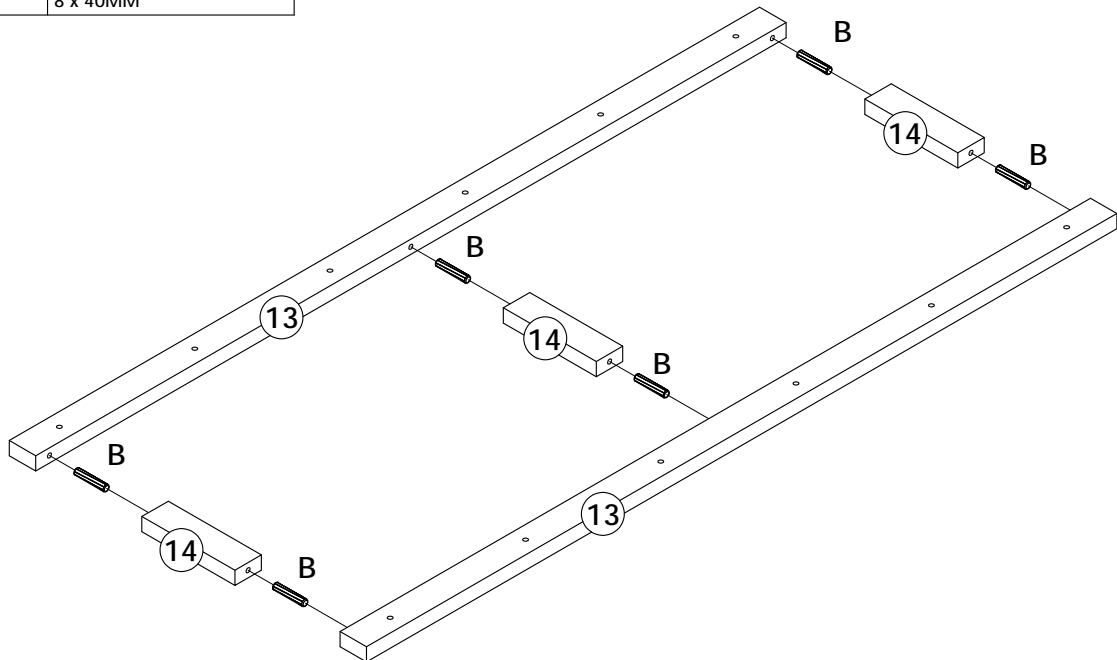
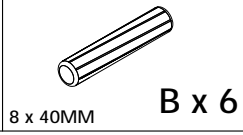

7

4 x 25MM  
E x 8

M6 x 35MM  
M x 12

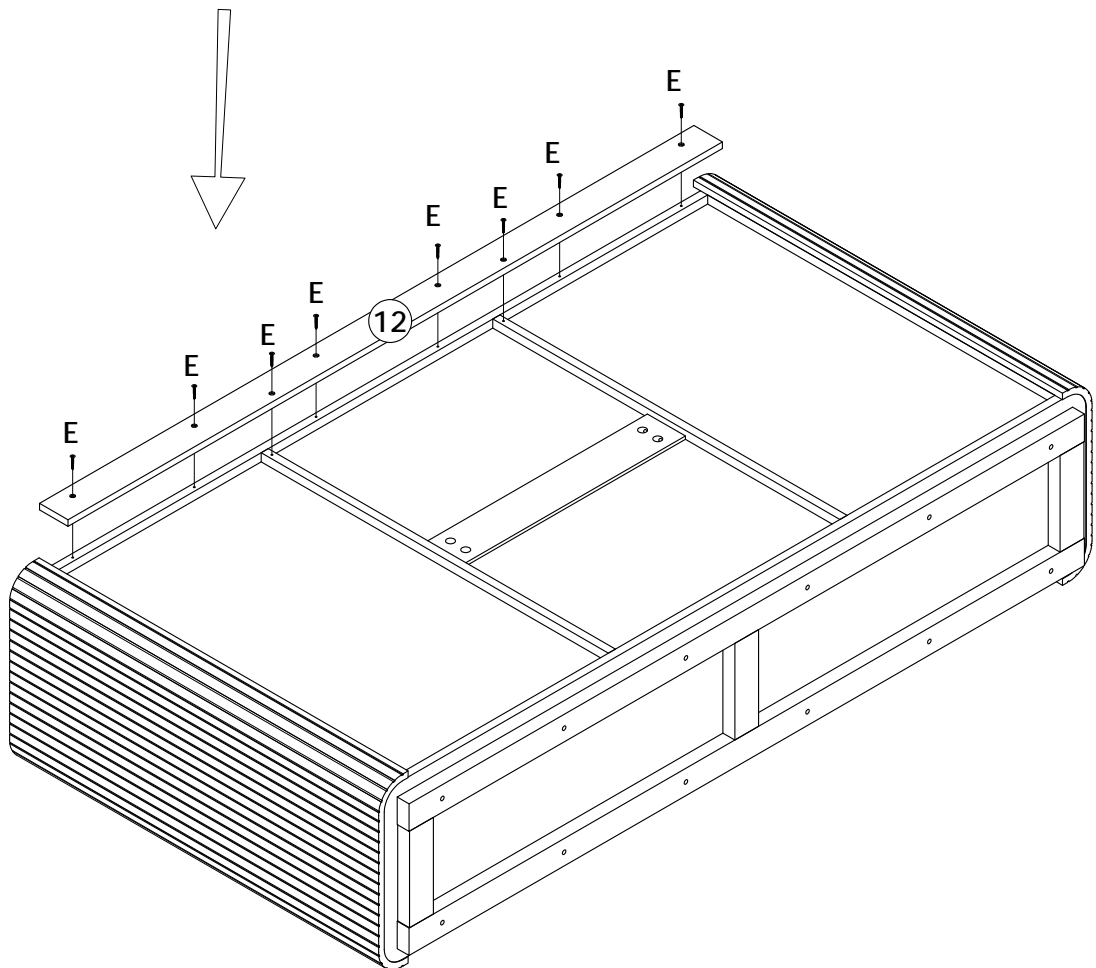
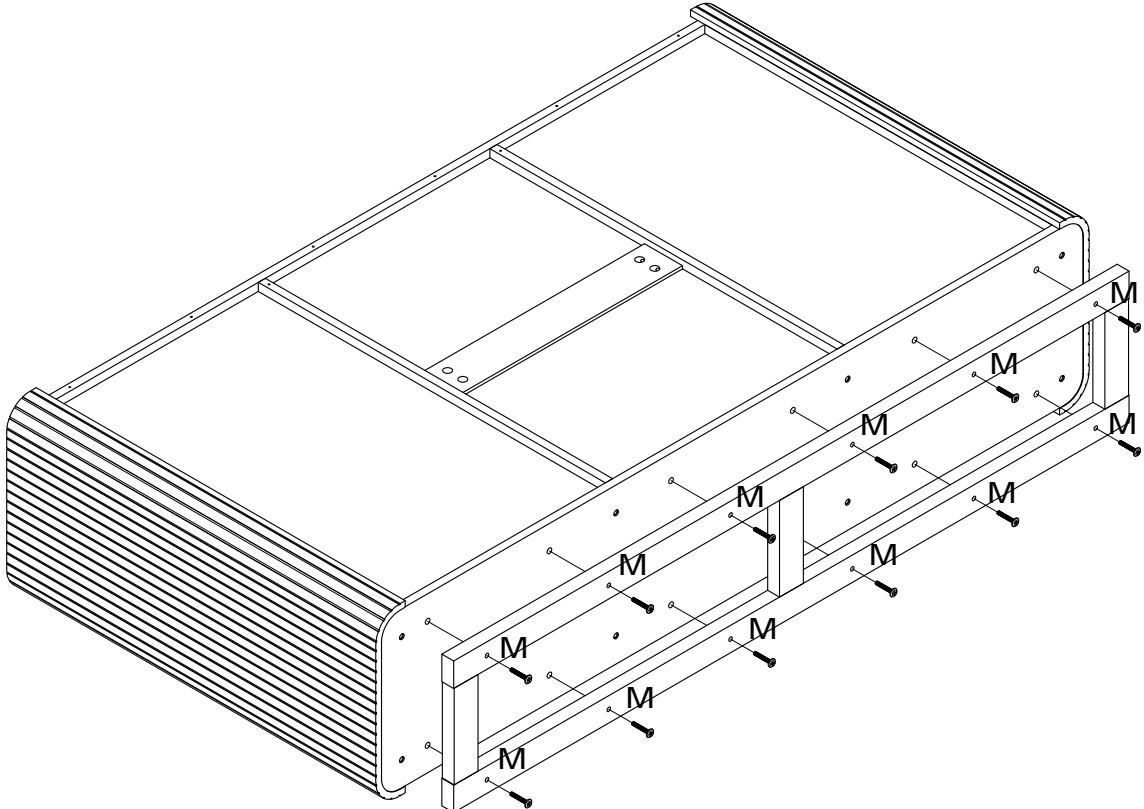

8

3.5 x 12MM C x 24

P x 24

R x 1

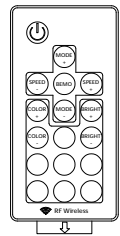
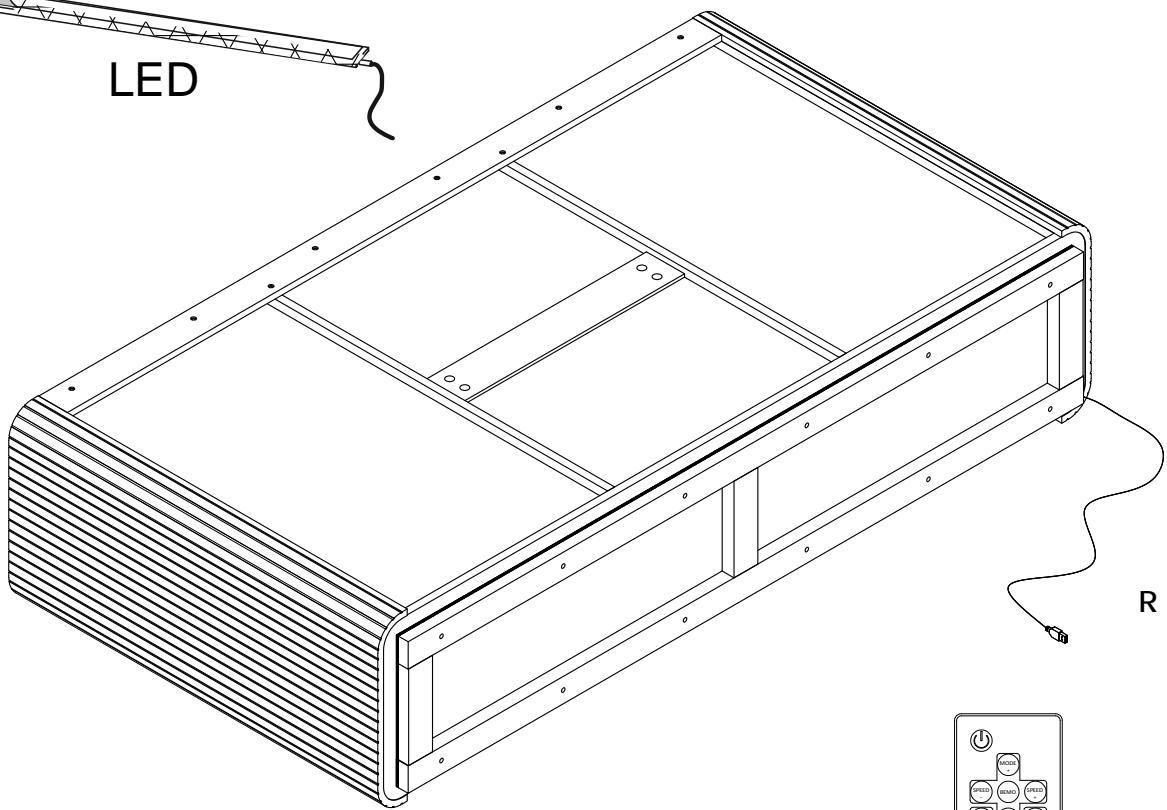
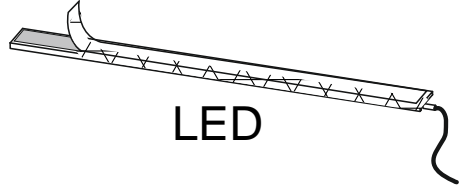
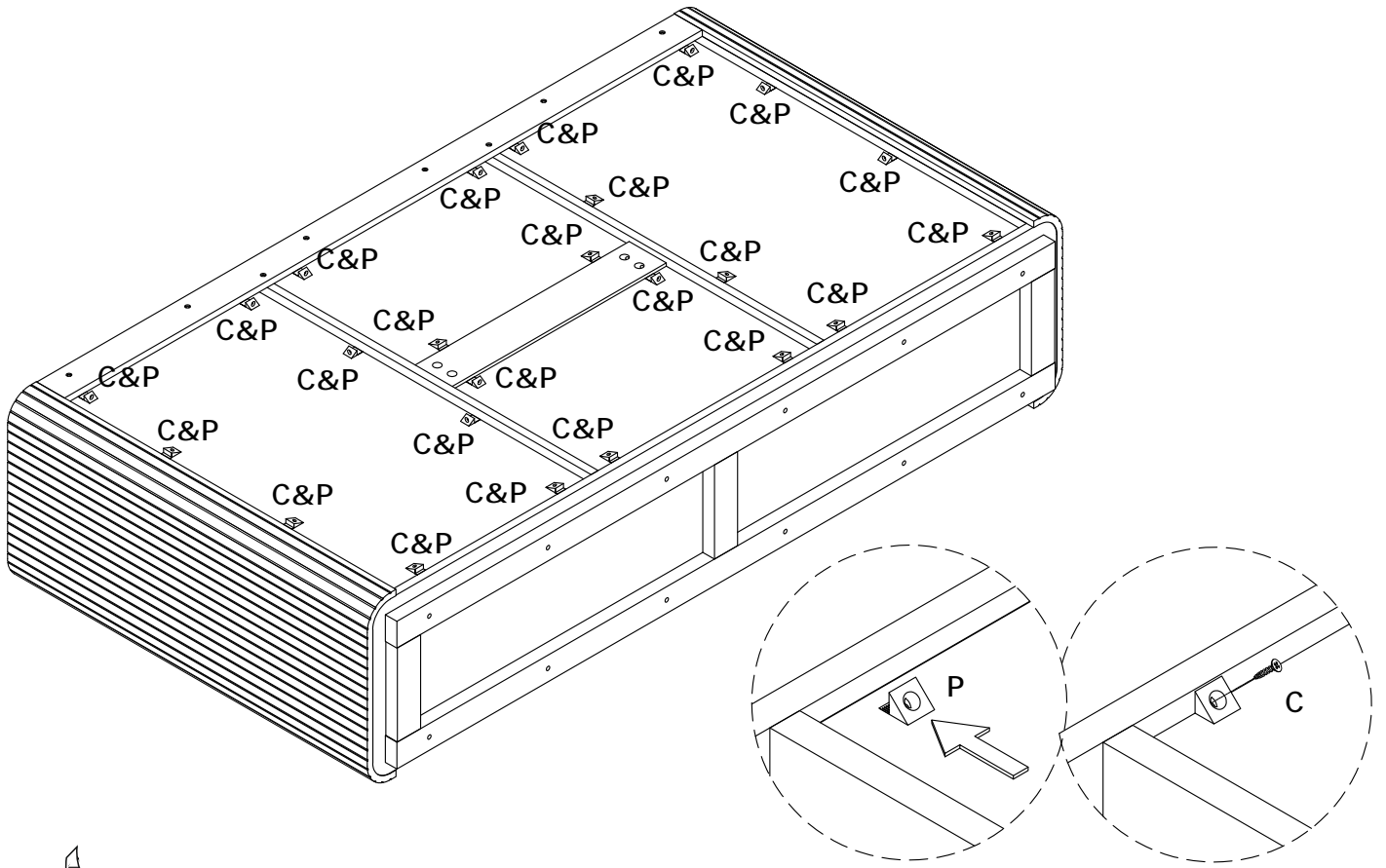



9

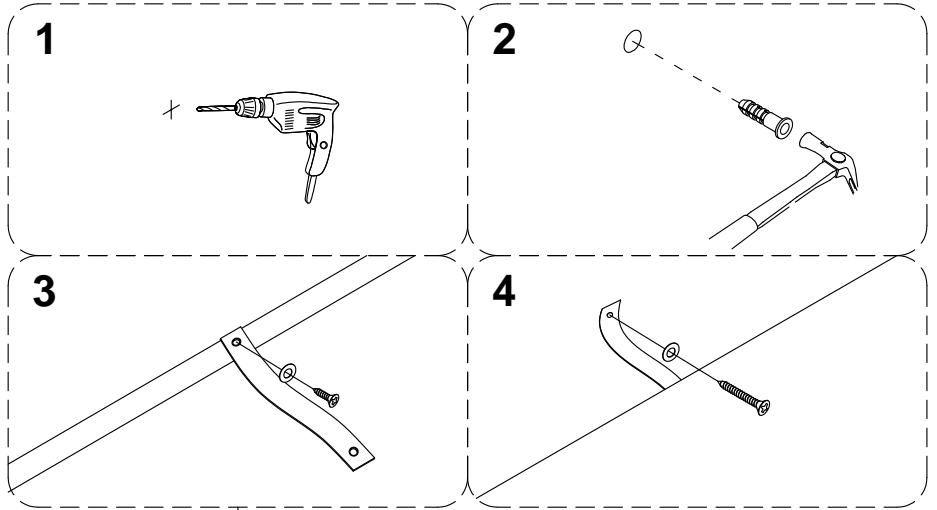
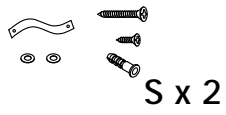

Wand  
Wall  
Parete  
Mur  
Pared

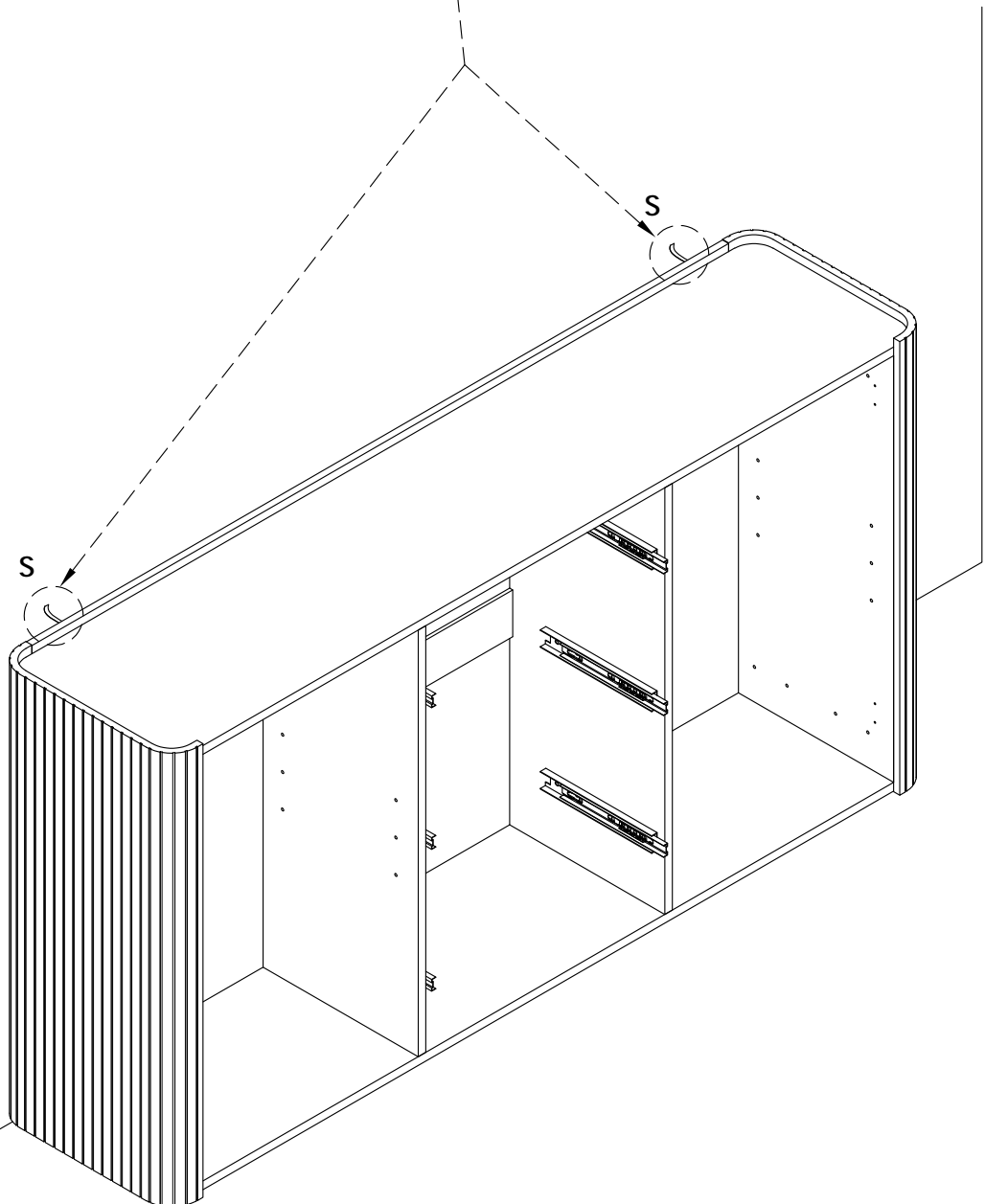

10



K1 x 12

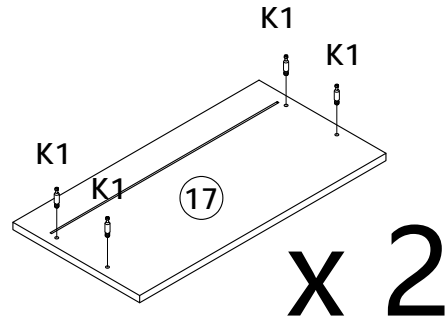
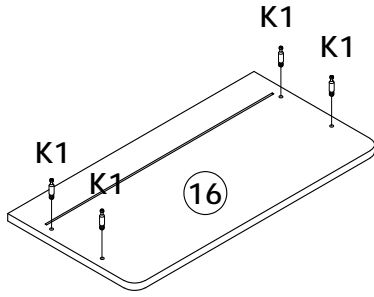

11



K2 x 12

3.5 x 12MM



C x 12

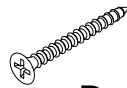

3.5 x 30MM

D x 12

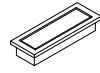

Q x 3



N2 x 6

x 3

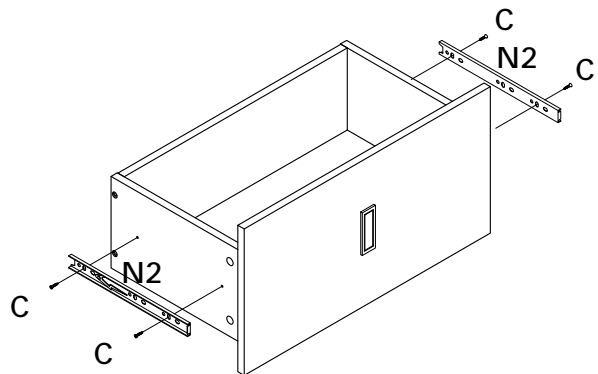
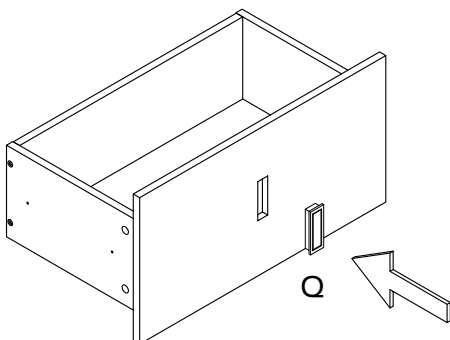
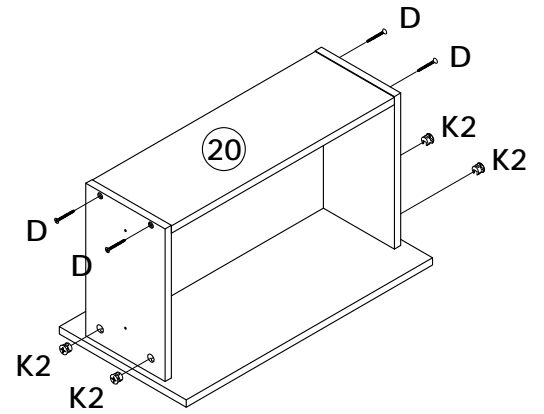
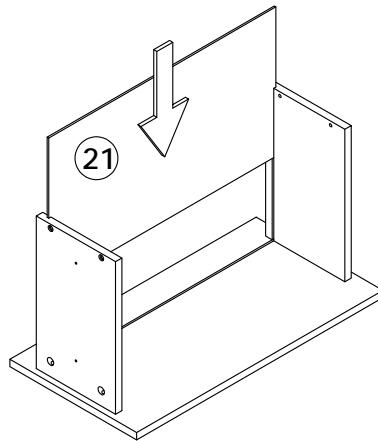
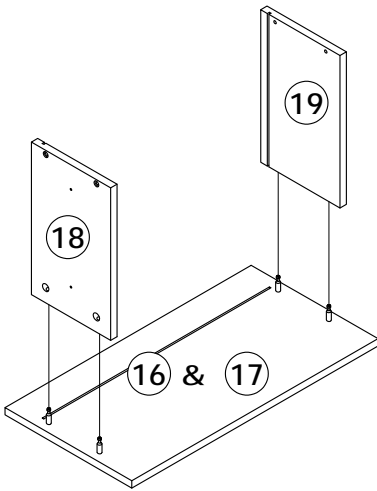

12

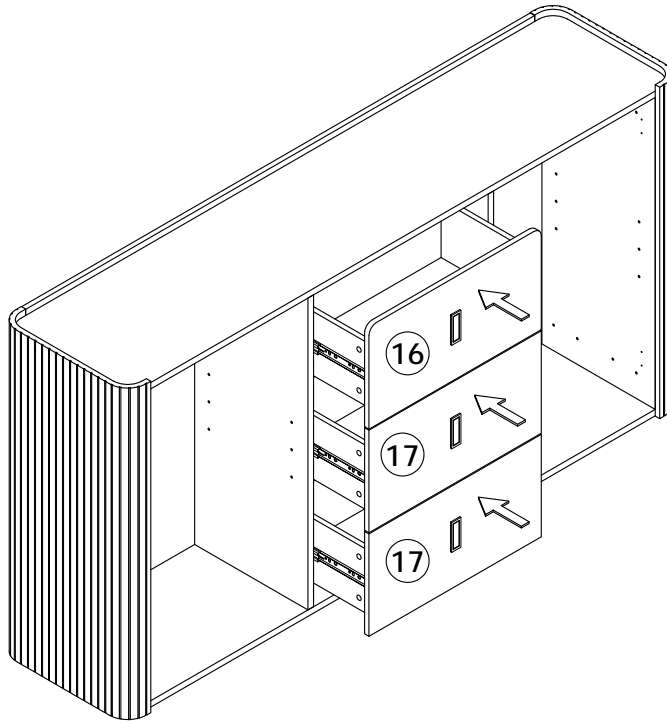

13



G x 8

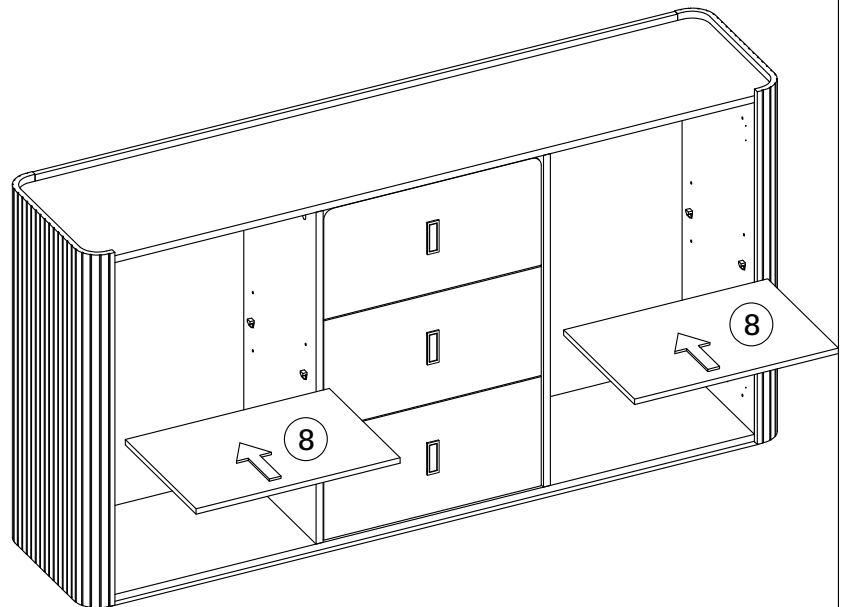
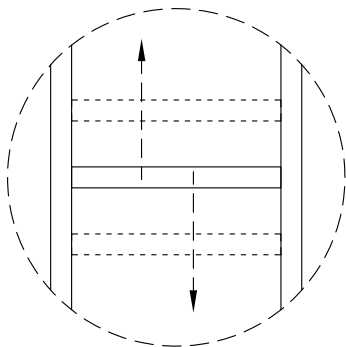
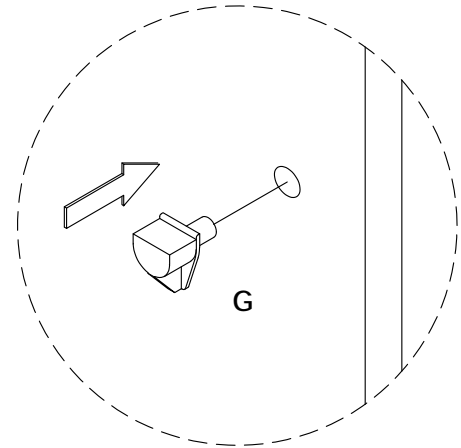
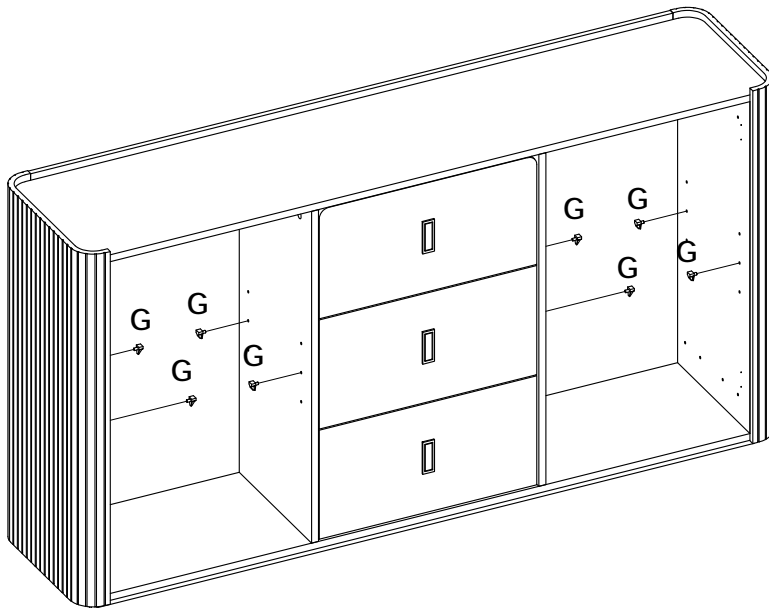

# 14

3.5 x 12MM

C x 8

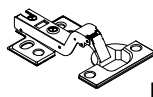

J x 4

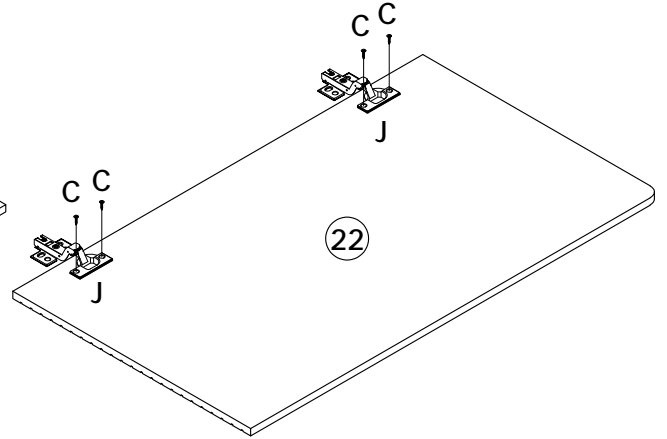
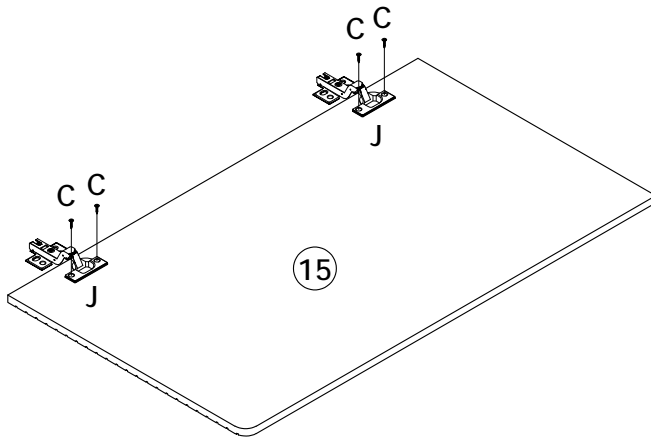

# 15

3.5 x 12MM

C x 16

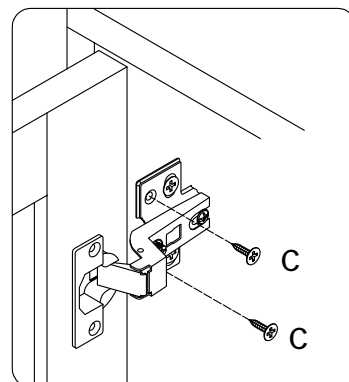
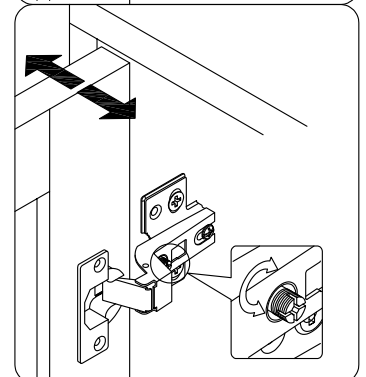
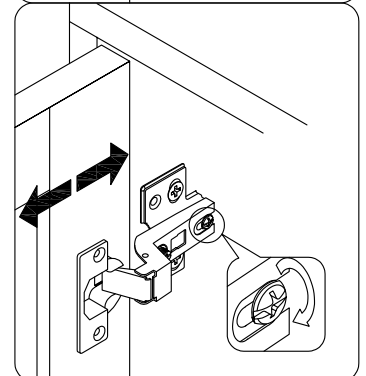
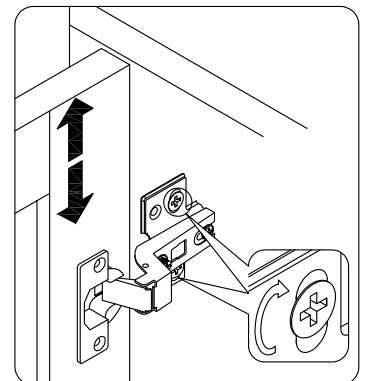
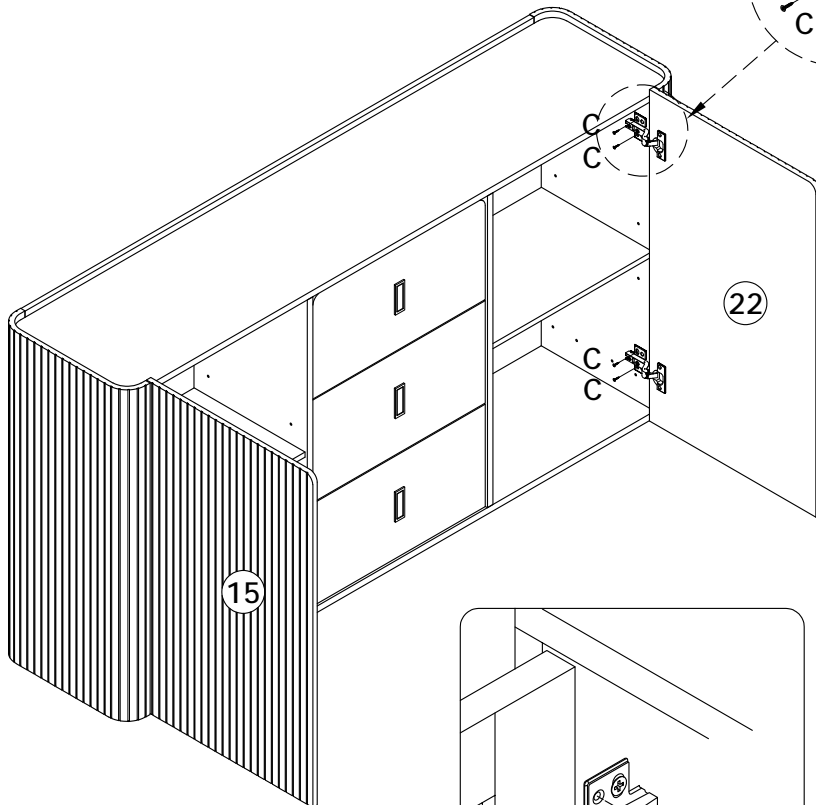
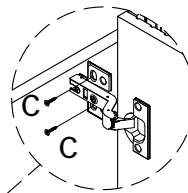

Bitte installieren Sie zuerst zwei Teile vom Typ C. Nachdem Sie die Spalte aller Türen gleichmäßig angepasst haben, fixieren Sie sie mit den anderen Teilen vom Typ C.

Please first install two parts of type C. After evenly adjusting the gaps of all doors, fix them with the other parts of type C.  
Si prega di installare prima due pezzi di tipo C. Dopo aver regolato uniformemente gli spazi di tutte le porte, fissateli con gli altri pezzi di tipo C.

Veillez d'abord installer deux pièces de type C. Après avoir ajusté uniformément les espaces de toutes les portes, fixez-les avec les autres pièces de type C.

Por favor, instale primero dos piezas de tipo C. Después de ajustar uniformemente los espacios de todas las puertas, fíjelos con las otras piezas de tipo C.

# Verification of Compliance

**Verification No.:** TMC210319126-E

**Name and address of Applicant:** **Shenzhen CWG Technology Co., Ltd**  
5 / F, No.264 Baoshi East Road, Shiyan street, Bao'an District, Shenzhen,China 518108

**Name and address of Manufacturer:** **Shenzhen CWG Technology Co., Ltd**  
5 / F, No.264 Baoshi East Road, Shiyan street, Bao'an District, Shenzhen,China 518108

**Product name:** **LED Strip**

**Rated:** DC12V

**Product model(s):** CWG-5050RGB-60D-12V , additional models reference attachment

**Product trademark:** 创唯光

This verification confirms that the product meets the requirements of the following standard. The conformity was demonstrated based on following standard(s) listed by European Commission as harmonized with EMC Directive 2014/30/EU.

EN IEC 55015:2019+A11:2020  
IEC 61547:2020

*The verification has been carried out in accordance with individual rules and conditions agreed with the applicant. Evaluation has been carried out in accordance with:*

**Test report(s) No.:** TMC210319126-E

**Test conducted by:** TMC Testing Services (Shenzhen) Co., Ltd.

**Verification issue date:** March 26, 2021

**Notes:**

*This verification refers to the above mentioned product and its conformity in regards of above mentioned standard(s) was proven on test sample.*

*This verification does not imply meeting all essential requirements, assessment of the series-production or any other restricted Notified Bodies conformity assessment procedure appropriate for the product.*

*This verification holder shall use this verification in connection to verification of conformity and technical data relevant for the product the verification was issued.*

**TMC Testing Services (Shenzhen) Co., Ltd.**

t:86-755-86642861 cert@tmc-lab.com www.tmc-lab.com

1st Floor, Block A1, Zone A, Xinshidai Gongrong Industrial Park, No. 2, Shihuan Road, Shiyan Street, Baoan District, Shenzhen, China



**Lab Director**  
Lemon Rao



## Verification of Compliance

CWG-5050RGB-30D-12V, CWG-5050RGB-18D-12V, CWG-5050RGB-60D-24V,  
CWG-5050RGB-60D-5V, CWG-5050RGB-30D-5V, CWG-5050RGB-18D-5V,  
CWG-5050-60D-12V, CWG-5050-30D-12V, CWG-5050-60D-24V,  
CWG-HC5050RGB-60D-12V, CWG-HC5050RGB-30D-12V,  
CWG-HC5050RGB-60D-24V, CWG-HC5050-60D-12V, CWG-HC5050-30D-12V,  
CWG-HC5050-60D-24V, CWG-HC5050RGB-30D-5V, CWG-HC5050RGB-60D-5V,  
CWG-HC5050RGB-144D-5V, CWG-2835-60D-12V, CWG-2835-120D-12V,  
CWG-2835-60D-24V, CWG-2835-120D-24V, CWG-2835-60D-5V, CWG-2835-120D-5V

Note:

This attachment only valided with Verification No.: TMC210319126-E