

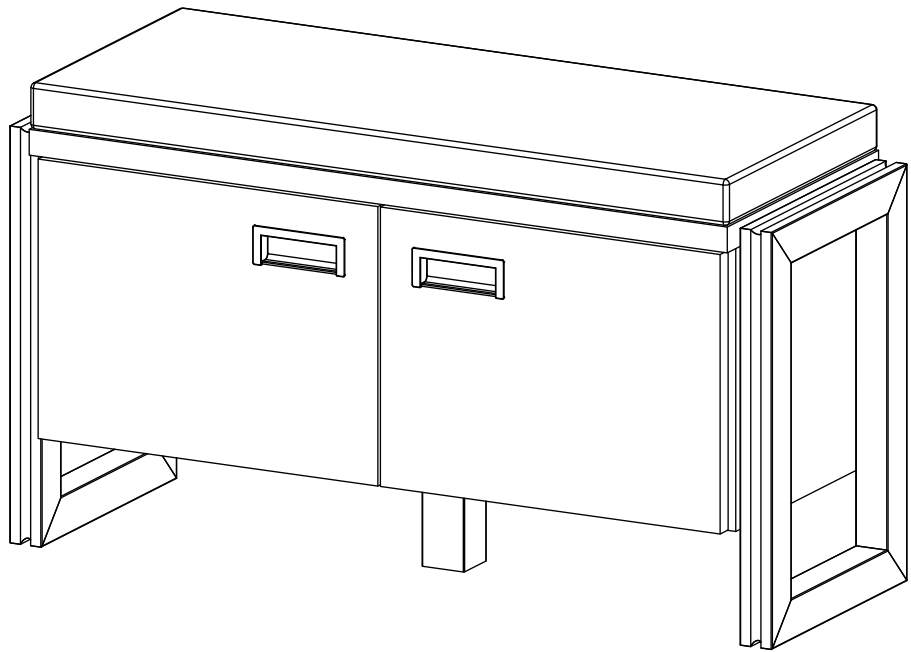

# DETROIT 79

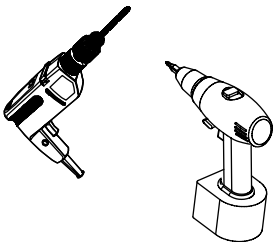

- Ⓚ Montageanleitung
- ⓃL Handleiding voor de montage
- ⓃR Montaj talimati
- ⓃF Instructions de montage
- ⓃZ Montá ní návod
- ⓃHU Összeszerelési útmutató
- ⓃGB Assembly instructions
- ⓃPL Instrukcja montażu
- ⓃRU Инструкция по монтажу
- ⓃIT Istruzioni di montaggio
- ⓃSK Montá ní návod
- ⓃRO Instrucțiuni de asamblare

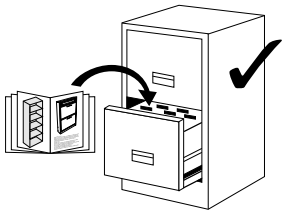
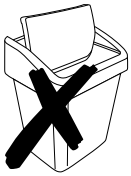
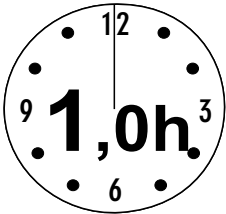
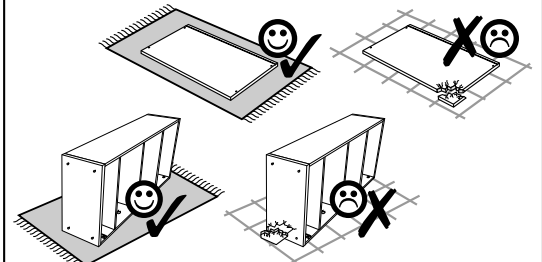
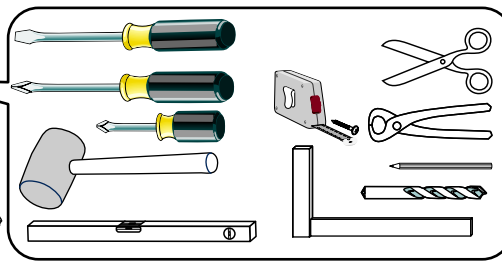
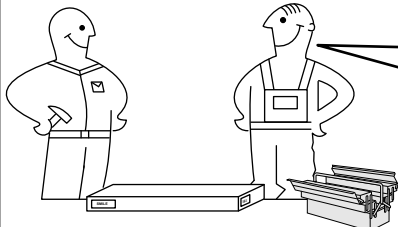

 <b>Achtung • Opgelet • Uwaga • Dikkat • Внимание • Attention</b> <b>•Upozornění • Figyelem • Attenzione • Atenție</b> 	
<b>D</b>	Überschreiten Sie angegebenen Maximalbelastungen nicht. Andernfalls kann das Möbelstück beschädigt oder zerstört werden.
<b>GB</b>	Do not exceed the maximum loads specified. Otherwise, the furniture may sustain damage or be irreparably damaged.
<b>NL</b>	Overschrijd de aangegeven maximale belastingen niet. Anders kan het meubelstuk worden beschadigd of vernield.
<b>PL</b>	Nie wolno przekraczać podanych maksymalnych wartości obciążenia. W przeciwnym razie mebel może zostać uszkodzony lub zniszczony.
<b>TR</b>	Belirtilen azami yük deđerini aţmayınız, aksi taktirde mobilya parçaları zarar görebilir veya kullanılamaz hale gelebilir.
<b>RU</b>	Не допускается превышение указанных максимальных нагрузок. В противном случае возможно повреждение или разрушение мебели.
<b>FR</b>	Ne dépassez pas les charges maximum indiquées. Sinon, le meuble peut être endommagé ou détruit.
<b>CZ</b>	Nepřekračujte uvedené maximální zatížení. V opačném případě může dojít k poškození nebo zničení nábytku.
<b>HU</b>	Tartsa be az engedélyezett maximális terhelhetőséget/teljesítményt. Különben a bútor és annak alkatrészei megsérülhetnek, tönk्रे mehetnek.
<b>IT</b>	Non superare il carico massimo indicato. Altrimenti il mobile rischia di rovinarsi o frantumarsi.
<b>RO</b>	Nu depășiți solicitările maxime specificate. Altfel puteți să deteriorați sau să distrugeți piesa de mobilier.
<b>SK</b>	Neprekročte uvedené maximálne zaťaženia. V opačnom prípade sa môže nábytok poškodiť alebo zničiť.
<b>D</b>	Die Befestigung des Möbelstückes an der Wand muss von einer fachkundigen Person vorgenommen werden, da für die Montage an die Wand angepasste Dübel erforderlich sind.
<b>GB</b>	A qualified professional is required when mounting furniture to the wall since dowels corresponding to the wall are required for this.
<b>NL</b>	Een vakkundige persoon dient het meubelstuk aan de muur te bevestigen; voor de montage aan de muur zijn immers aangepaste pluggen vereist.
<b>PL</b>	Mocowanie mebla do ściany mogą przeprowadzić wyłącznie wykwalifikowane osoby, z uwagi na zastosowanie odpowiednio dopasowanych kołków do rodzaju ściany.
<b>TR</b>	Mobilya parçasının duvara sabitlenmesi, duvar montajı için özel uyarlanmış dübeller gerektirdiğinden bu iş sadece bu konuda uzman bir kişi tarafından gerçekleştirilmelidir.
<b>RU</b>	Поскольку для монтажа на стене необходимо использовать специальные дюбели, мебель должна быть закреплена на стене квалифицированным персоналом.
<b>FR</b>	La fixation du meuble contre le mur doit être effectuée par une personne compétente car, pour le montage mural, il faut utiliser des chevilles adaptées.
<b>CZ</b>	Montáž nábytku na stěnu musí provést odborník, protože k montáži na stěnu jsou zapotřebí upravené hmoždinky.
<b>HU</b>	A bútorlemez falra rögzítését szakembernek kell végeznie, mert a rögzítéshez megfelelő tiplit kell használni.
<b>IT</b>	Il fissaggio del mobile alla parete deve essere eseguito da persone esperte, dato che occorrono tasselli adeguati.
<b>RO</b>	Fixarea la perete a piesei de mobilier se realizează numai de către personal competent, deoarece montajul de perete necesită dibluri adecvate.
<b>SK</b>	Upevnenie nábytku na stenu musí vykonať odborník, nakoľko sú pre montáž na stenu potrebné vhodné hmoždinky.

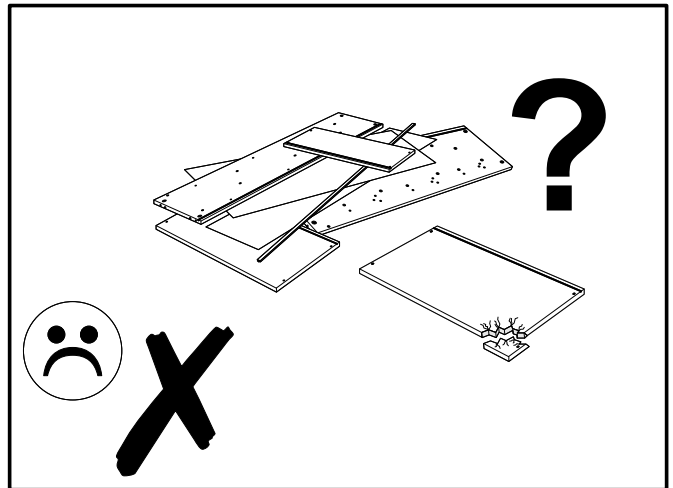
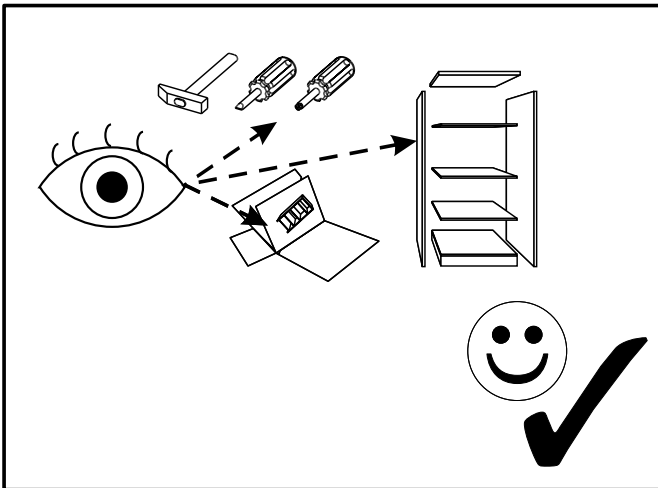
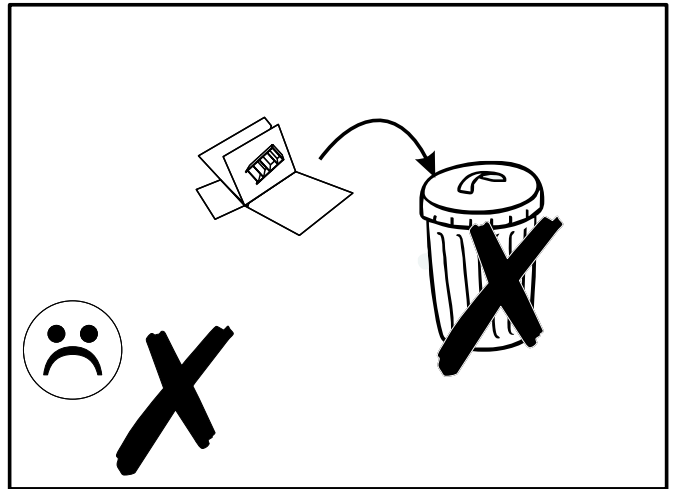
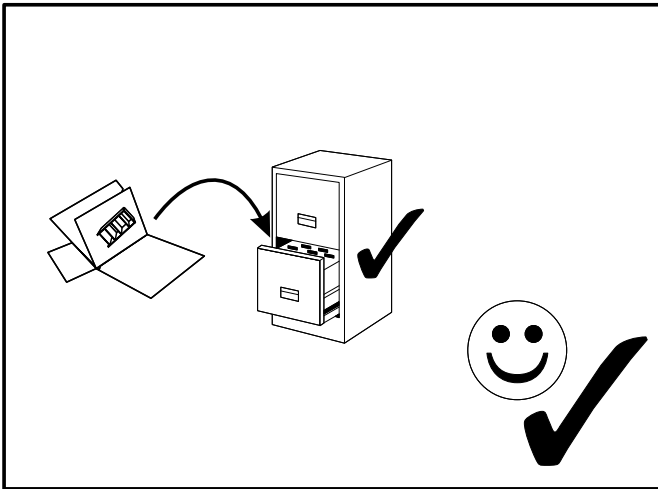
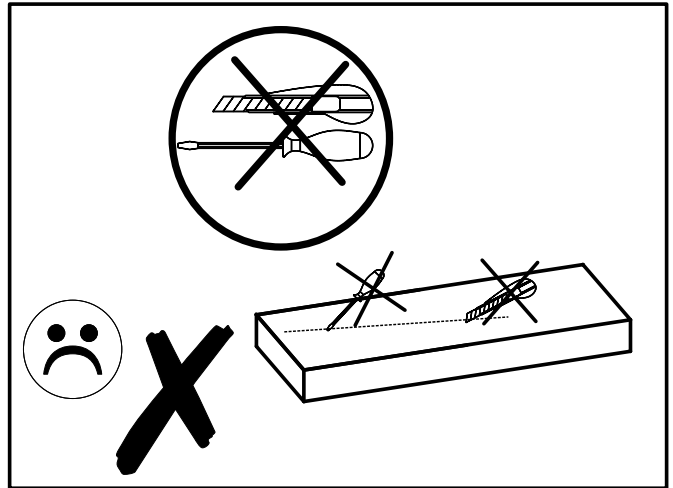
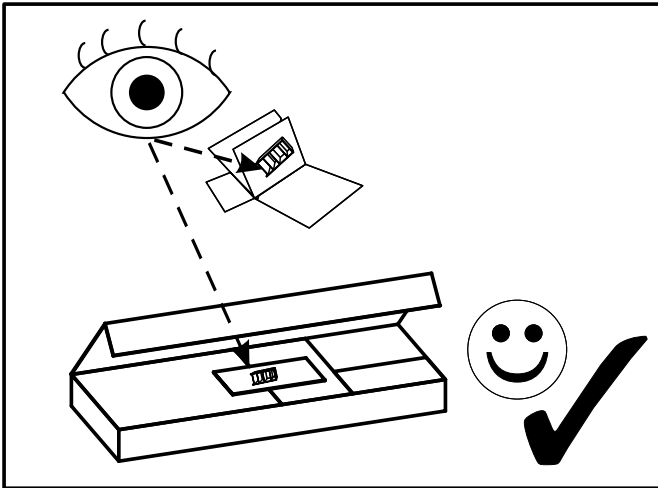



# DETROIT 79

MM  
260  
250  
240  
230  
220  
210  
200  
190  
180  
170  
160  
150  
140  
130  
120  
110  
100  
90  
80  
70  
60  
50  
40  
30  
20  
10  
0

**NR 1**

**B1**   $\phi 8 \times 28$  x22

**M1**  x6

**T1**  x6

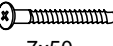
**K1**  7x50 x6

**C6**  x6

**J23**  x6

**P3**  3x20 x8

**L13**  x4

**W1**  x8

**NR 2**

**U276**  x2

**P13**  3,5x13 x4

**NR 3**

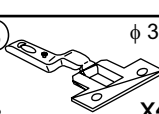
**Z3**   $\phi 35$  x4

Kr8

**Y4**  H2 x4

**S3**  3,5x13 x8

**NR 4**

**F15**   $\phi 28$  x5

**P6**  4x30 x8

**NR 5**

**L1**  x1

**NR 6**

**11**  x1

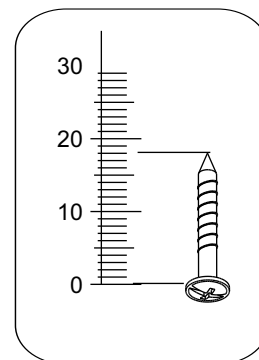

# DETROIT 79



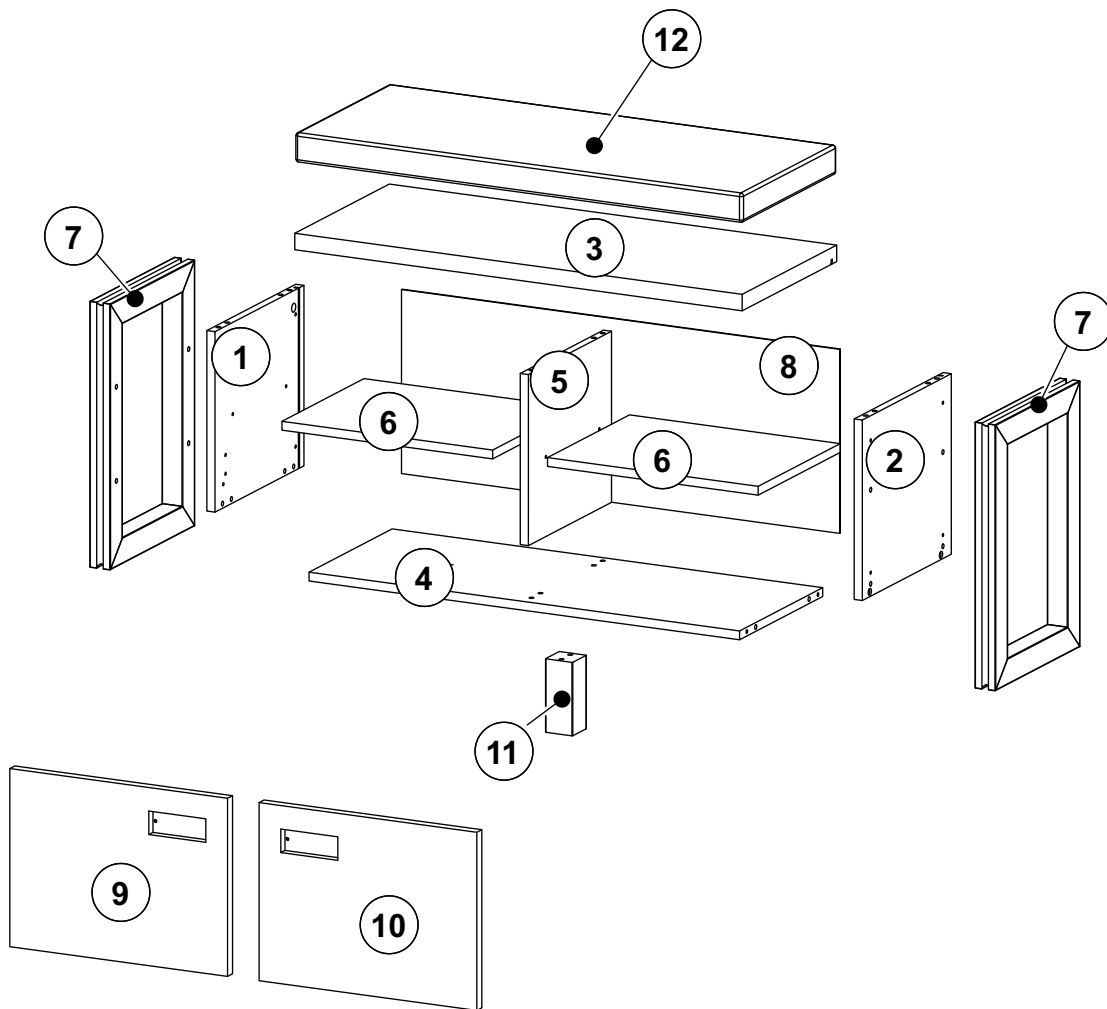

⑥ = **5kg**

⑫ = **90kg**





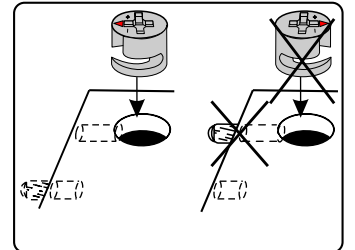
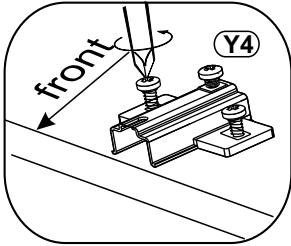
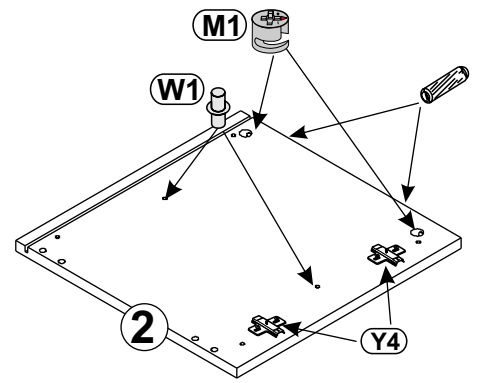
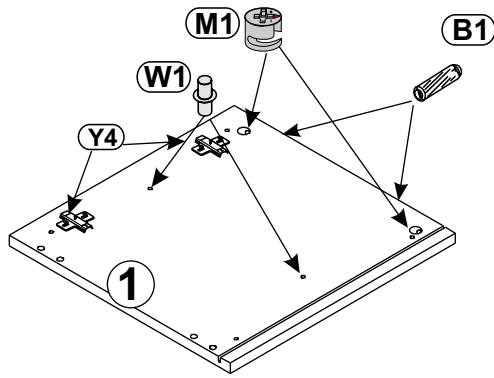

①	307	320	15	1	1/1
②	307	320	15	1	1/1
③	824	340	28	1	1/1
④	793	299	15	1	1/1
⑤	291	299	15	1	1/1
⑥	388	295	15	2	1/1
⑦	452	304	38	2	1/1
⑧	807	313	2,5	1	1/1
⑨	401	303	18	1	1/1
⑩	401	303	18	1	1/1
⑪	125	50	50	1	1/1
⑫	824	340	50	1	1/1

# 1

- B1**   $\phi 8 \times 28$  x4
- M1**  x4
- Y4**  H2 x4
- W1**  x4



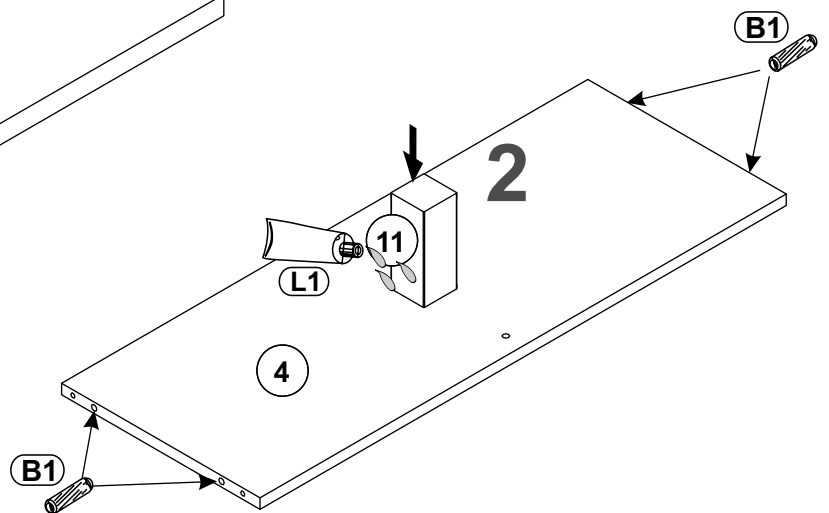
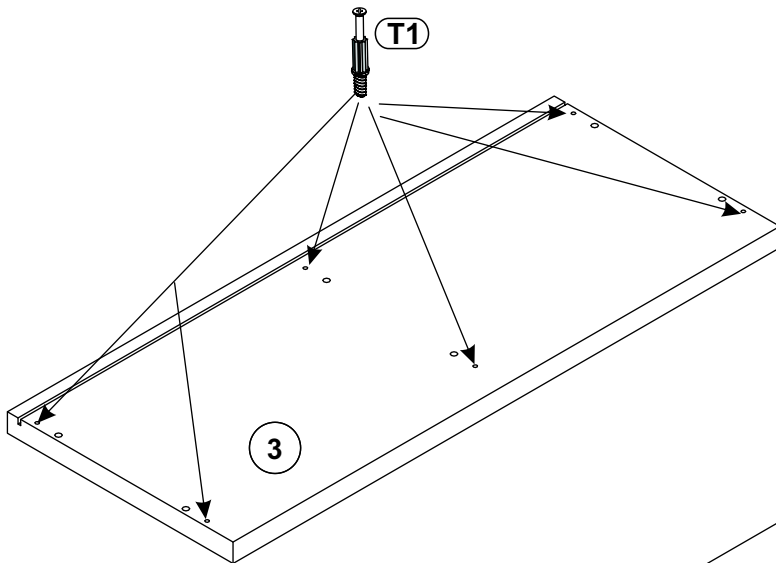
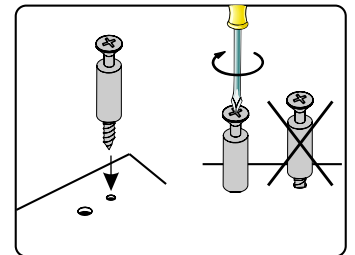
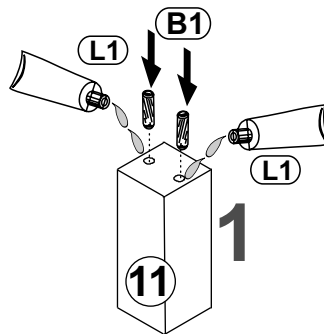

# 2

- T1**  x6
- B1**   $\phi 8 \times 28$  x6
- 11**  x1
- L1**  x1



3

**B1**   $\phi 8 \times 28$  x4

**M1**  x2

**W1**  x4

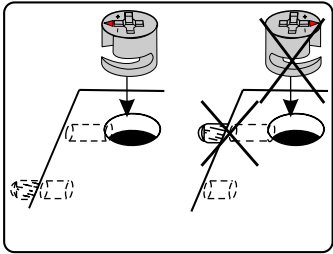
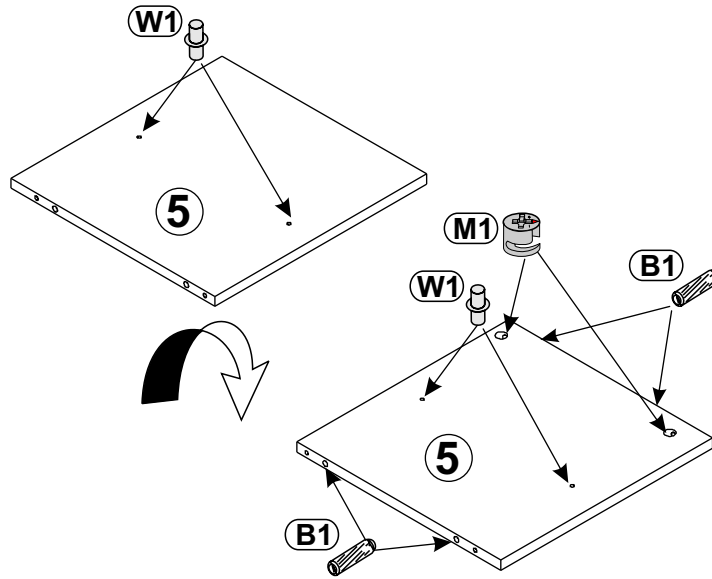

4

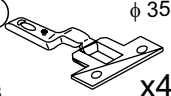
**Z3**   $\phi 35$   
Kr8 x4

**S3**   $3,5 \times 13$  x8

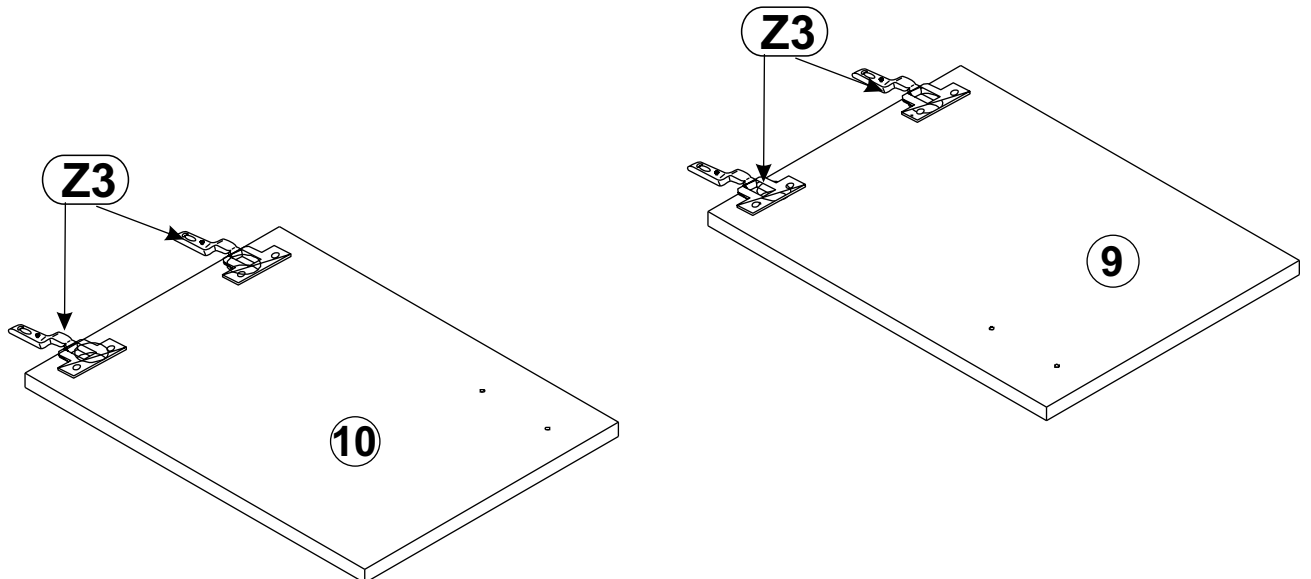
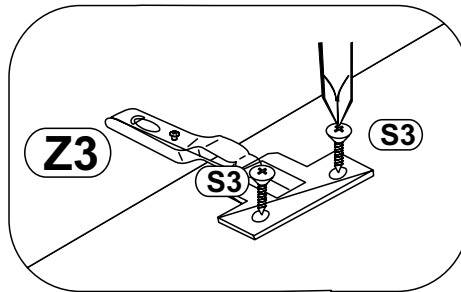

5

**K1**  7x50 x6

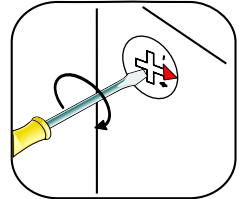
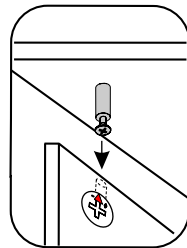
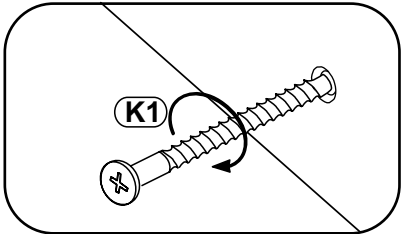
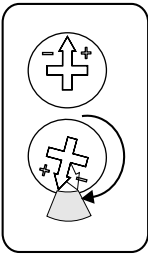
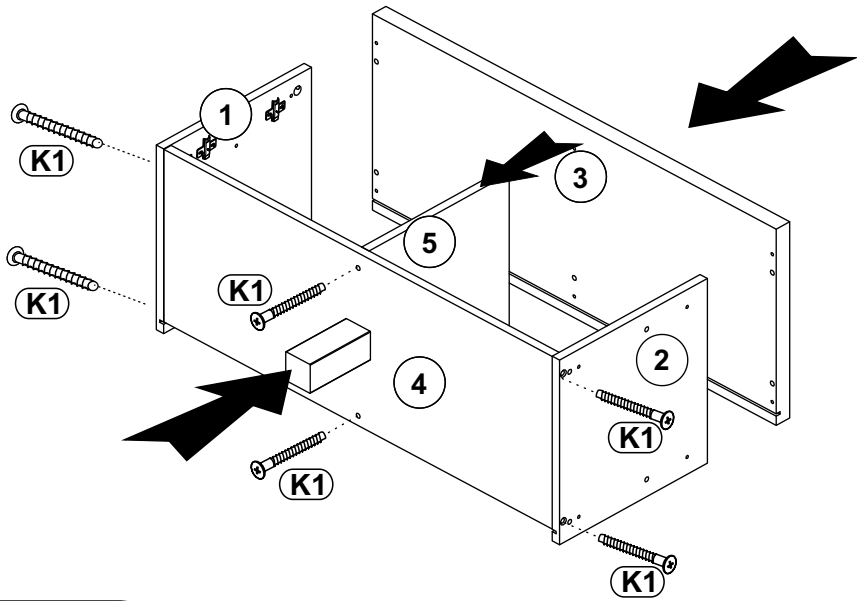

6

**B1**   $\phi$  8x28 x8

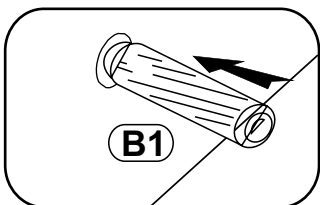
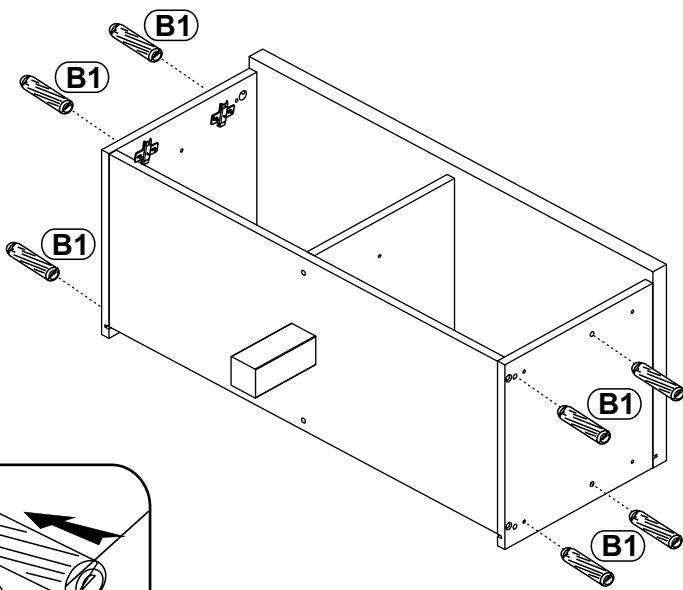



# 7

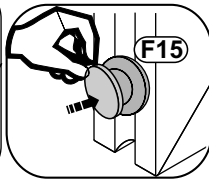
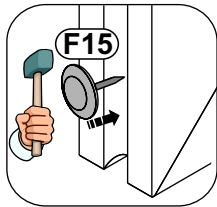
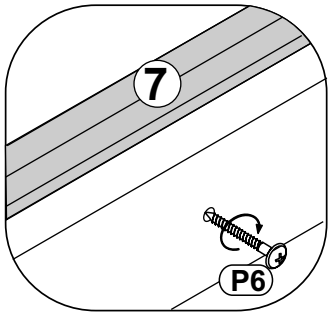
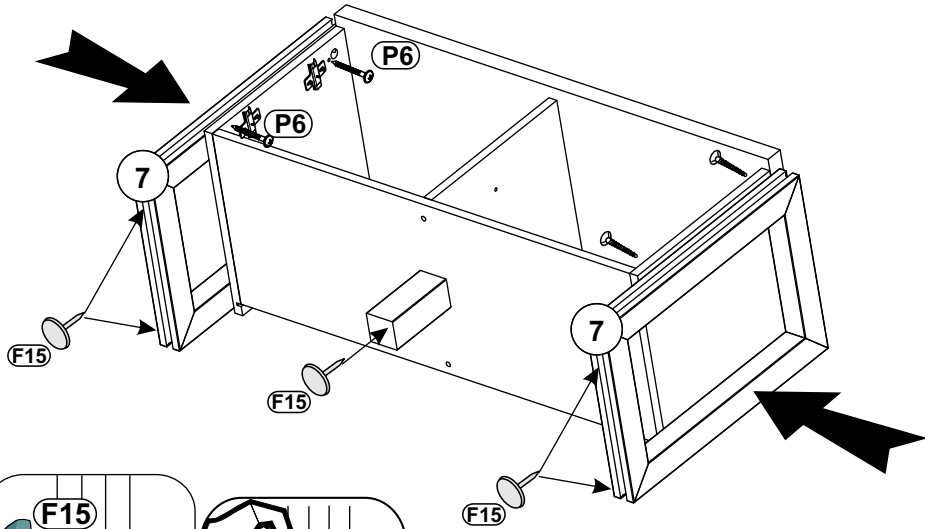
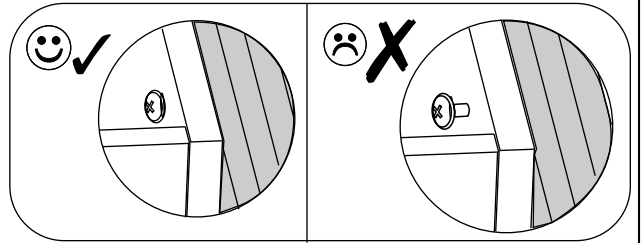
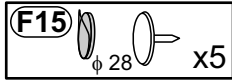
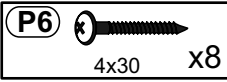

# 8

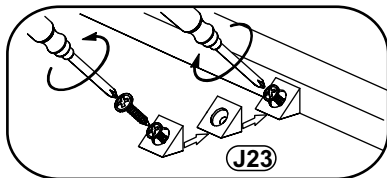
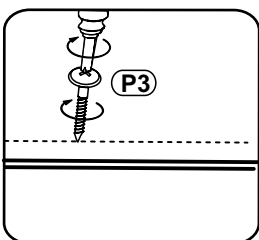
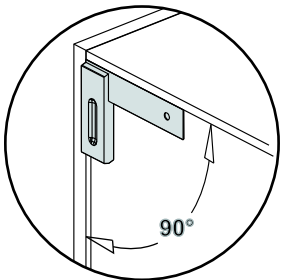
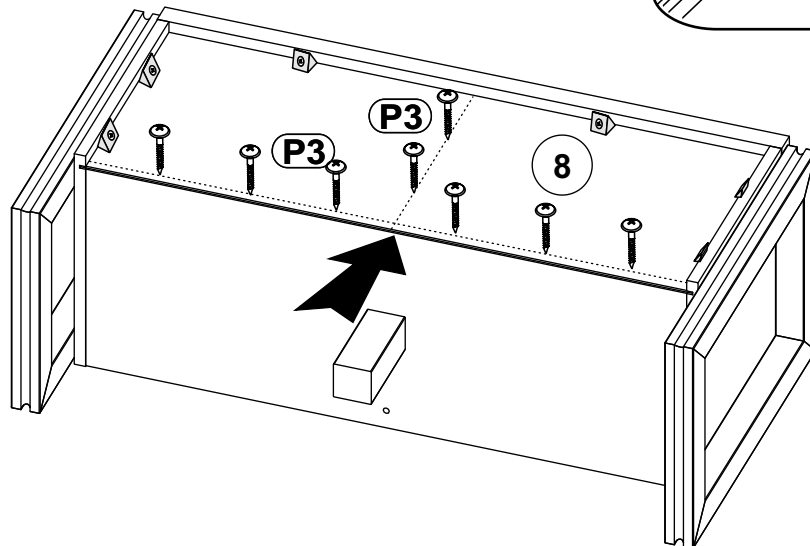
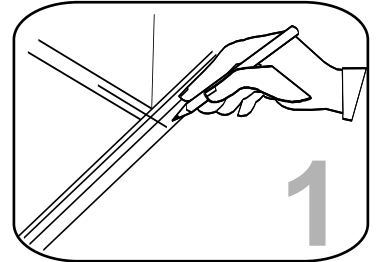
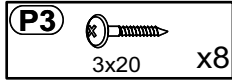
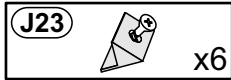

9

