

- | | |
|---|---|
| (D) Montageanleitung
3787 | (GB) Assembly instructions
3787 |
| (FR) Notice de montage
3787 | (IT) Istruzioni di montaggio
3787 |
| (NL) Handleiding voor de montage
3787 | (PL) Instrukcja montażu
3787 |
| (CZ) Montážní návod
3787 | (SK) Návod na montáž
3787 |
| (HU) Szerelési útmutató
3787 | (RO) Instrucțiuni de montaj
3787 |
| (TR) Montaj talimatı
3787 | (RU) Инструкция по монтажу
3787 |

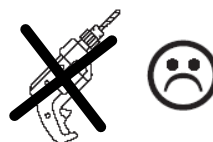
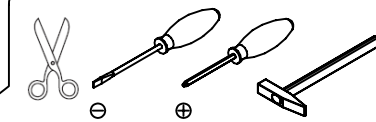
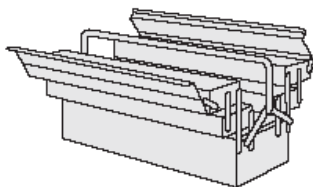

0
10
20
30
40
50
60
70
80
90
100
110
120
130
140
150
160
170
180
190
200

Service • Dienstverlening • Serwis • Servis • Сервисная служба

Name • Naam • Nazwa • İsim • Название	
Nr. • No. • Номер	
Typ • Type • Tip • Тип	

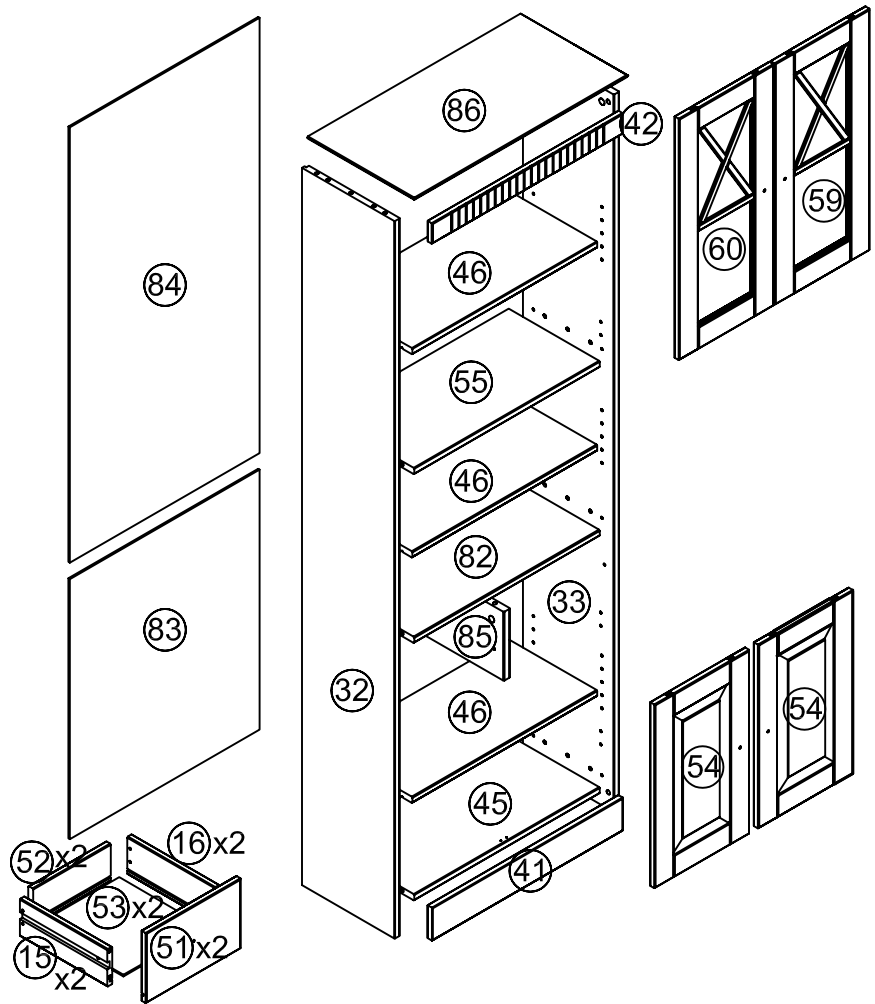

A Ø8x30mm 35x 	B Ø6.5x34mm 18x 	C Ø15x11mm 18x 	D 4mm 1x 	E Ø5x16mm 12x 	F 20x1.2mm 50x 	G Ø4x30mm 4x 	H 20x20x16mm 1x 	I Ø4x60mm 1x
J Ø3.5x15mm 17x 	K 22x22mm 4x 	L Ø12x18mm 4x 	M 246mm 4x 	N D Leim GB Glue NL Lijm PL Klej TR Tutkal RU Клей 1x 	O M4x10mm 4x 	P Ø5.8x9mm 8x 	R Ø28x29mm 6x 	S Ø26mm 8x
T 36x52mm 8x 	U Ø3.5x35mm 14x 	Bc 40x20x17mm 1x 	Bd Ø3x12mm 2x 	Lu 45x18mm 1x 				

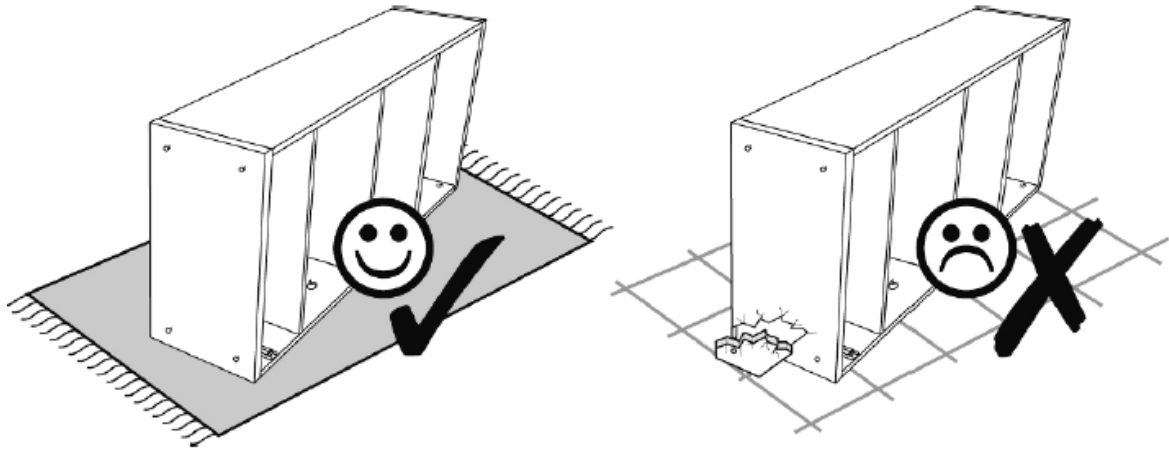

1

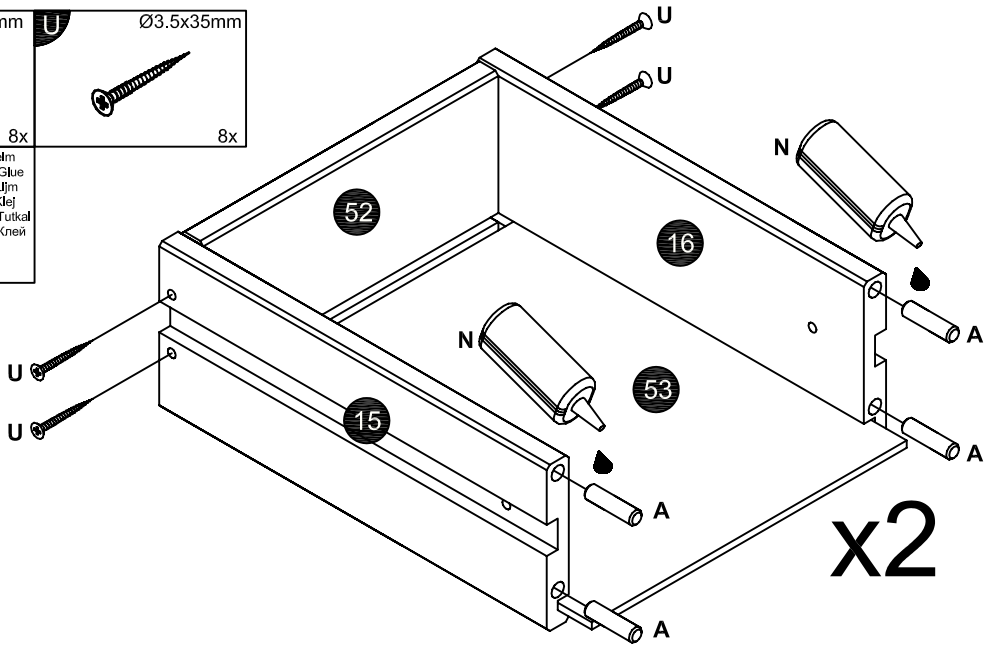
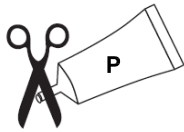
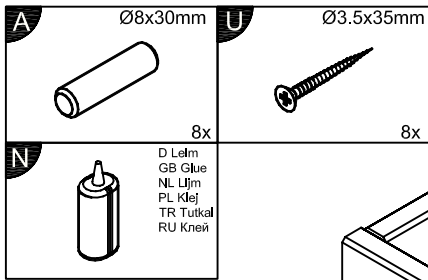

2

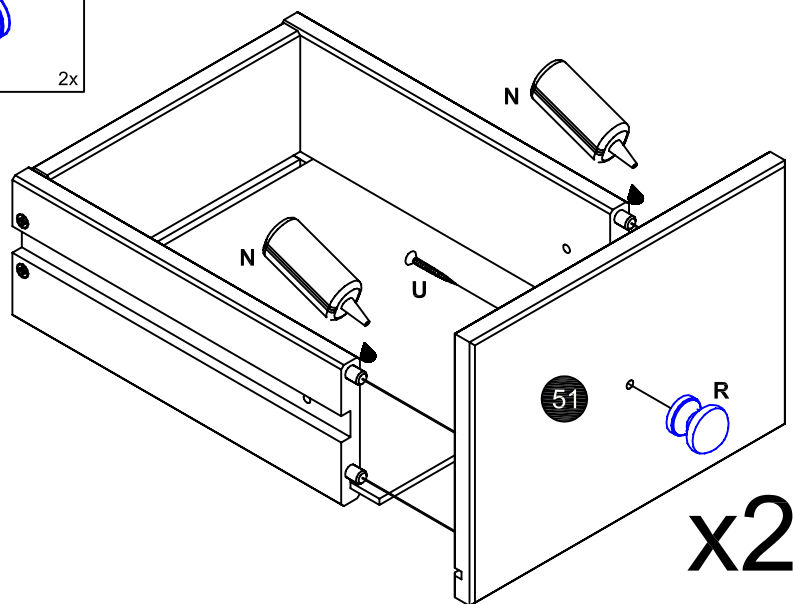
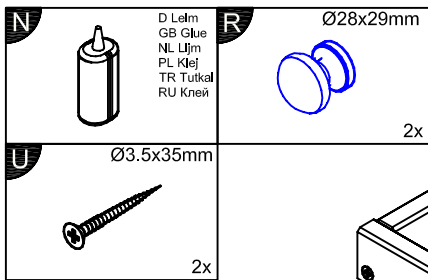

3

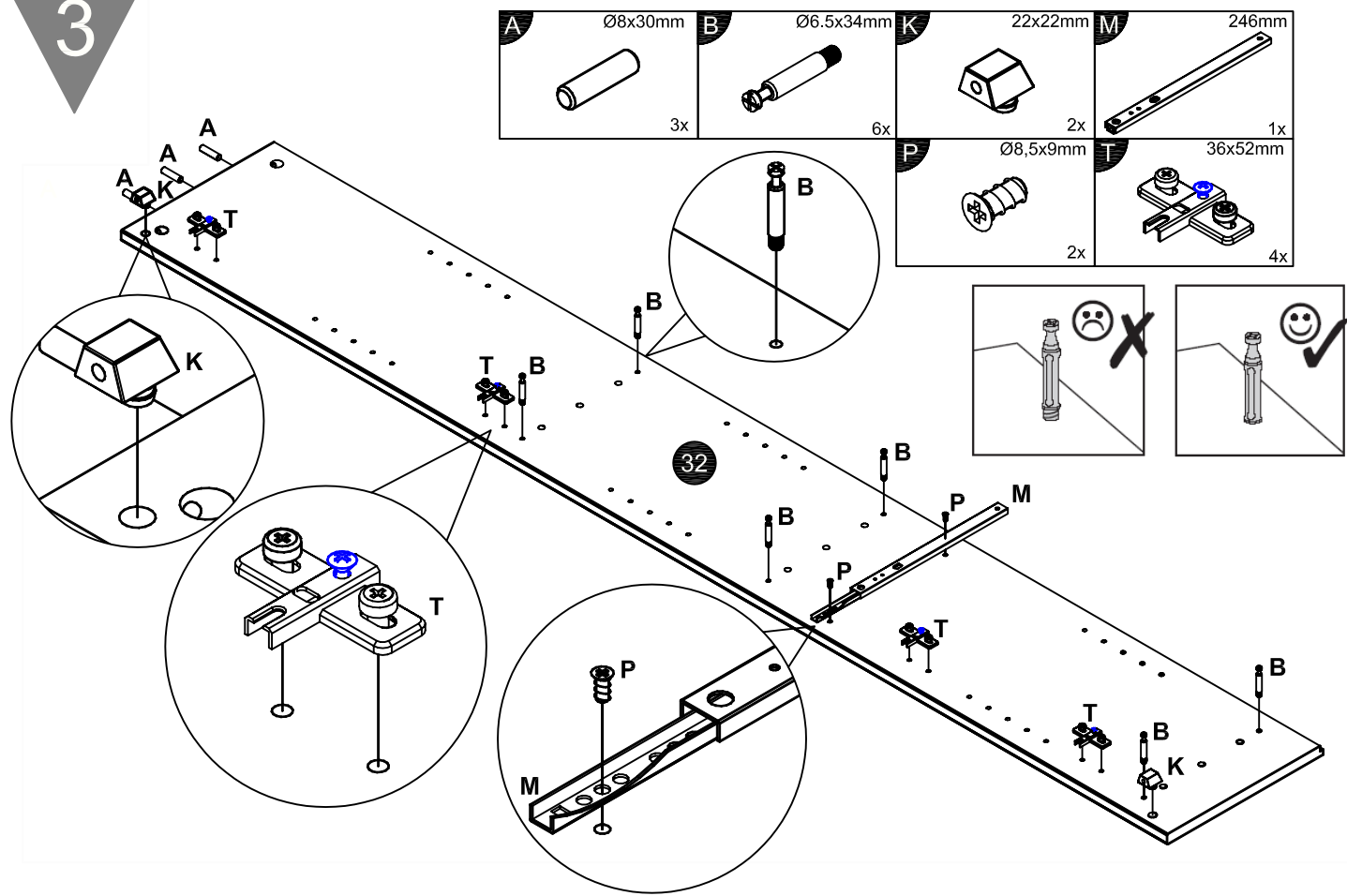

4

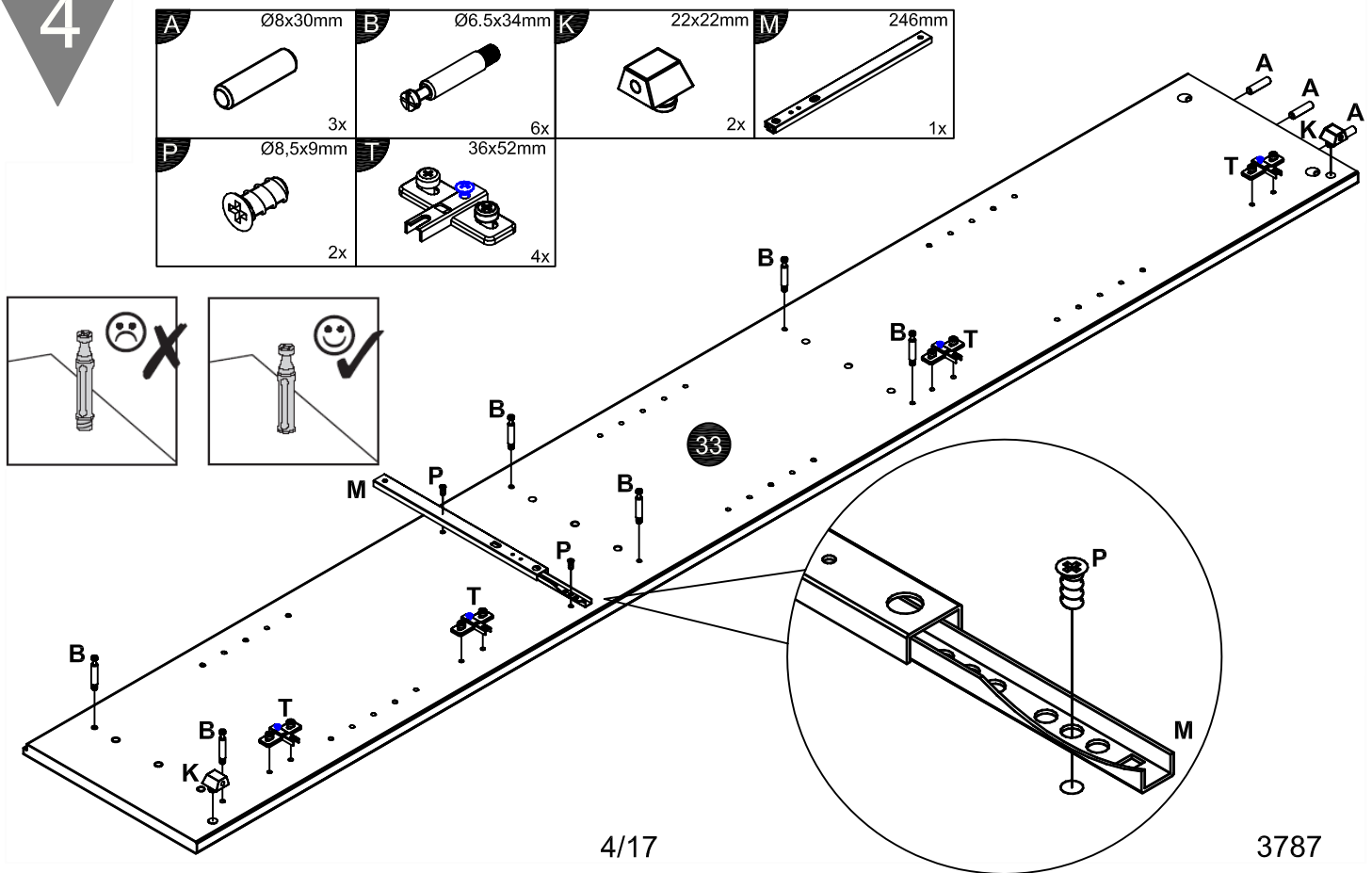

5

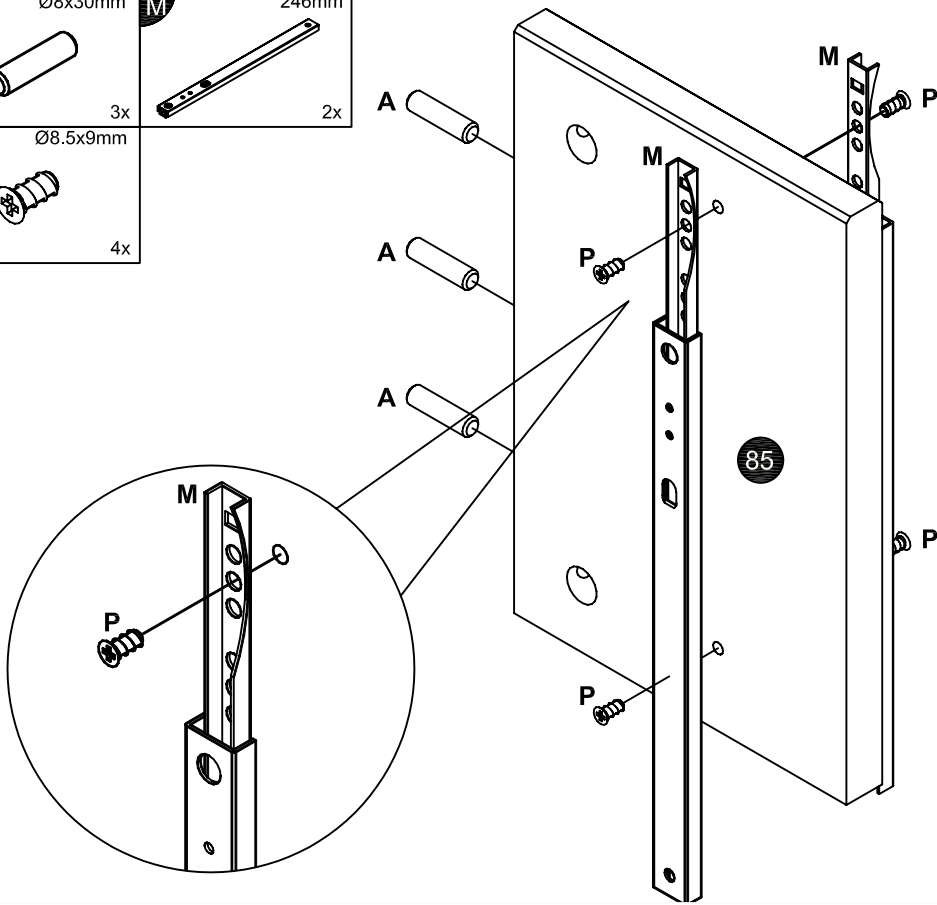
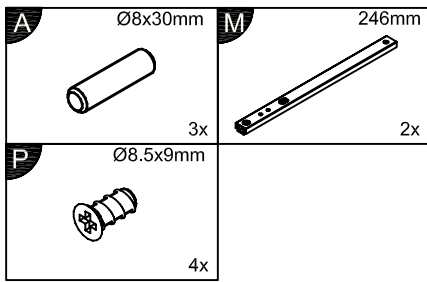

6

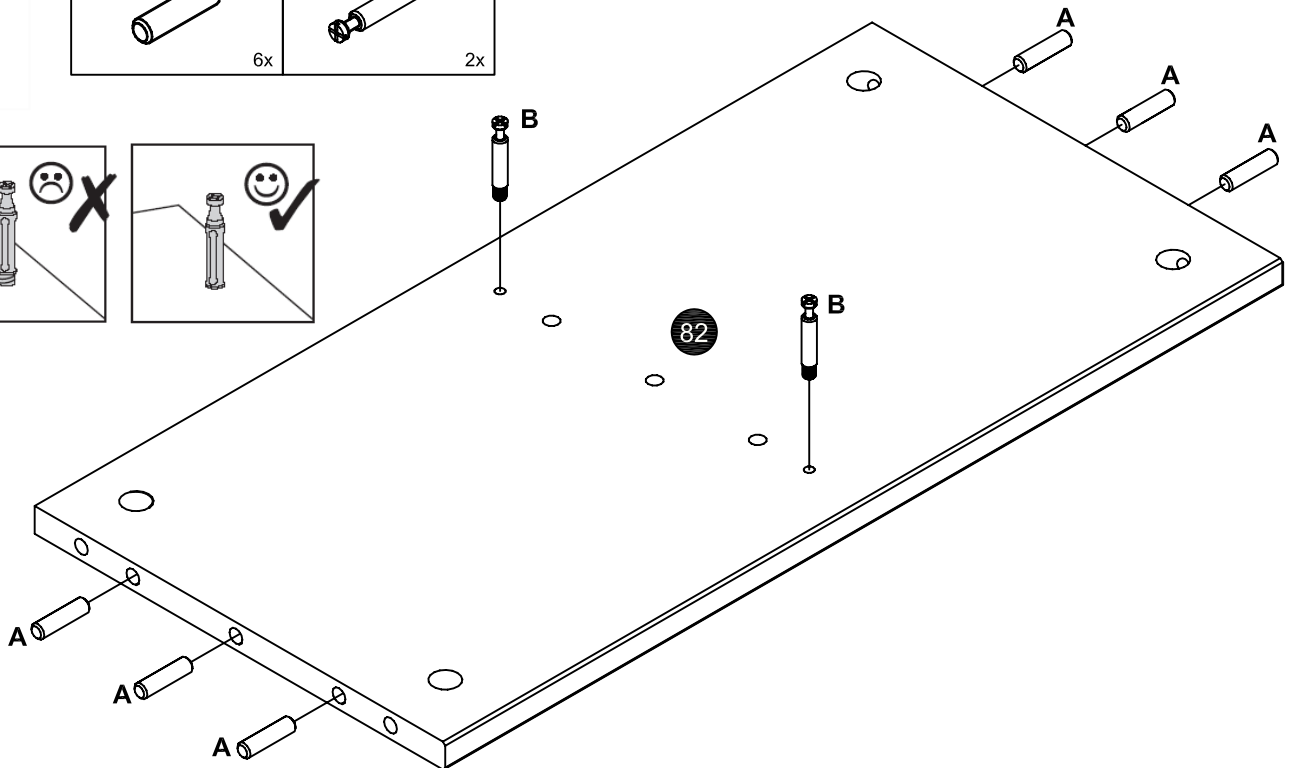
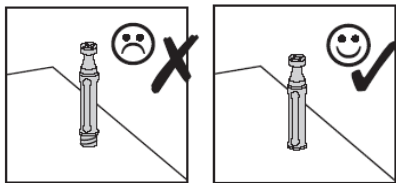
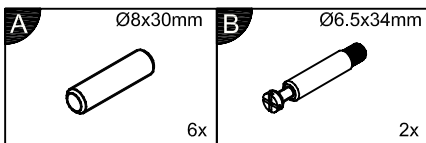

7

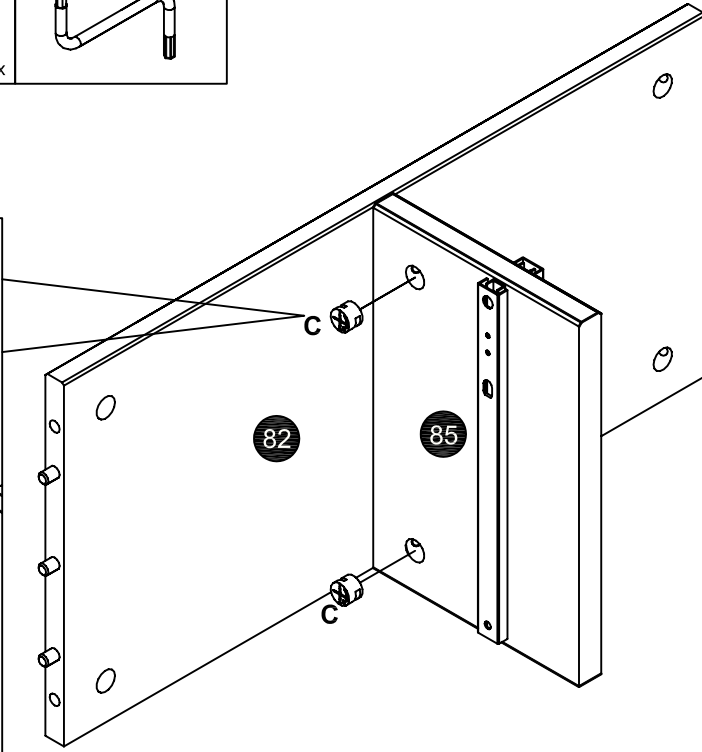
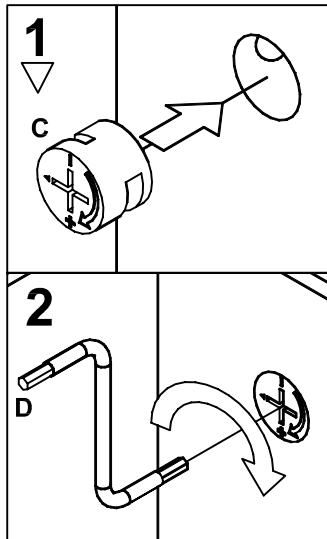
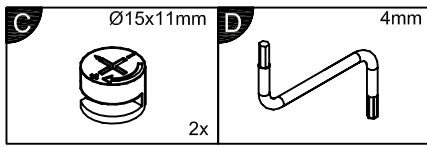

8

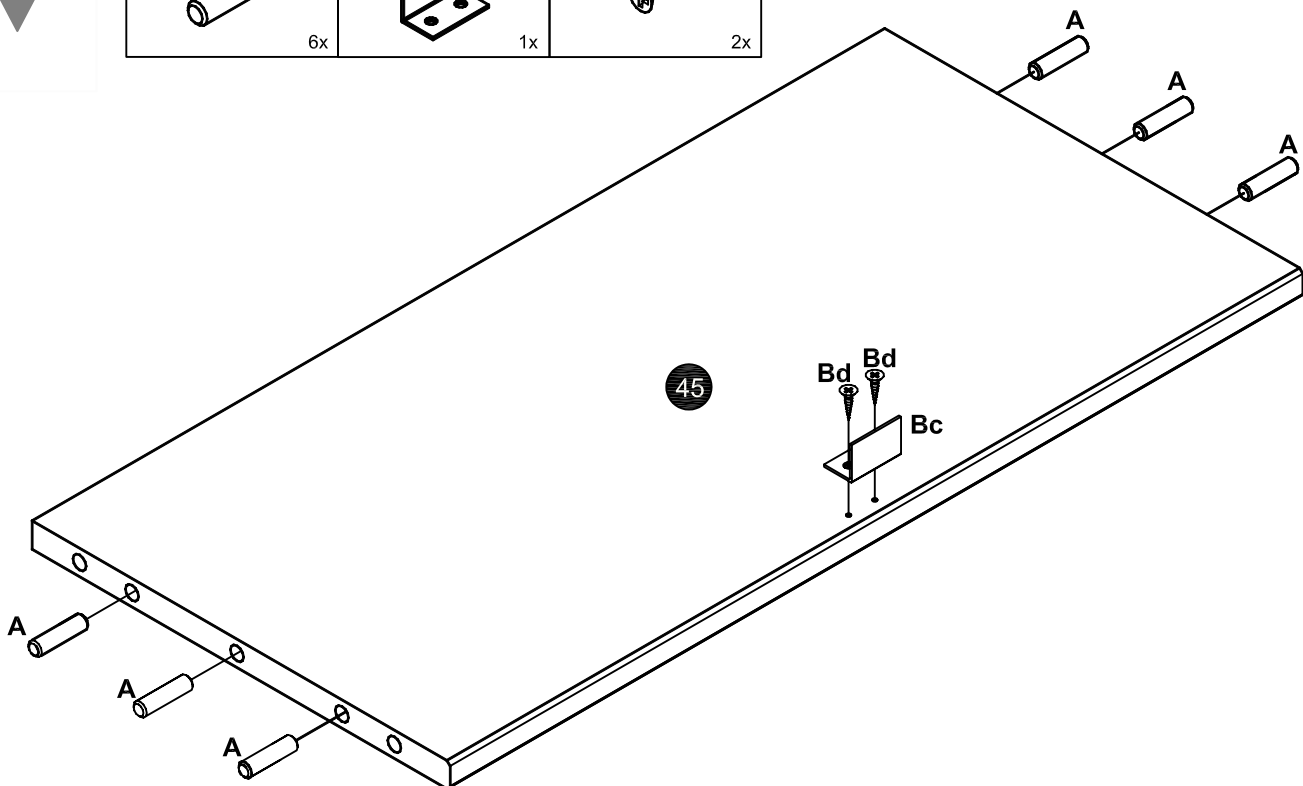
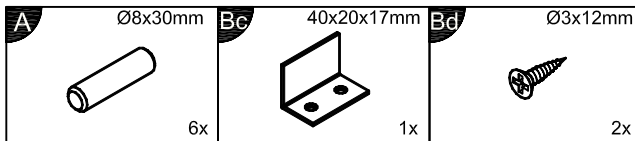

9

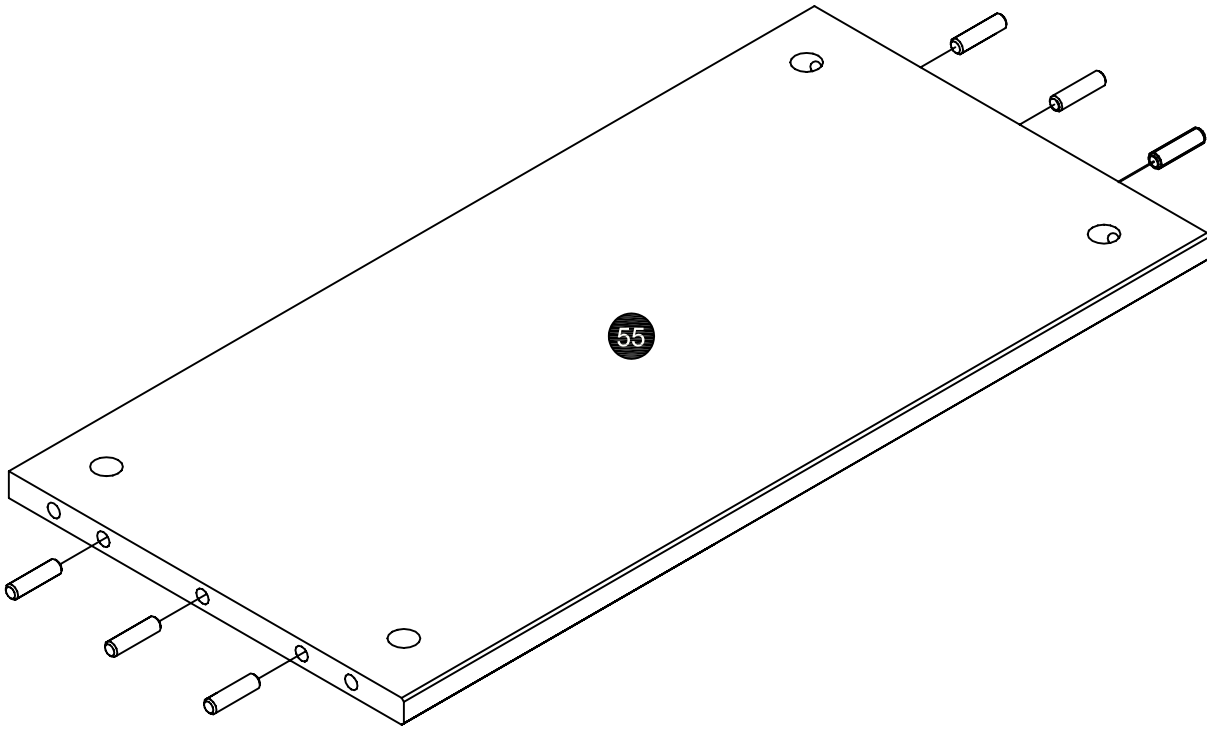
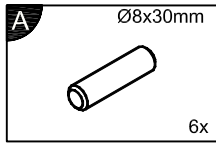

10

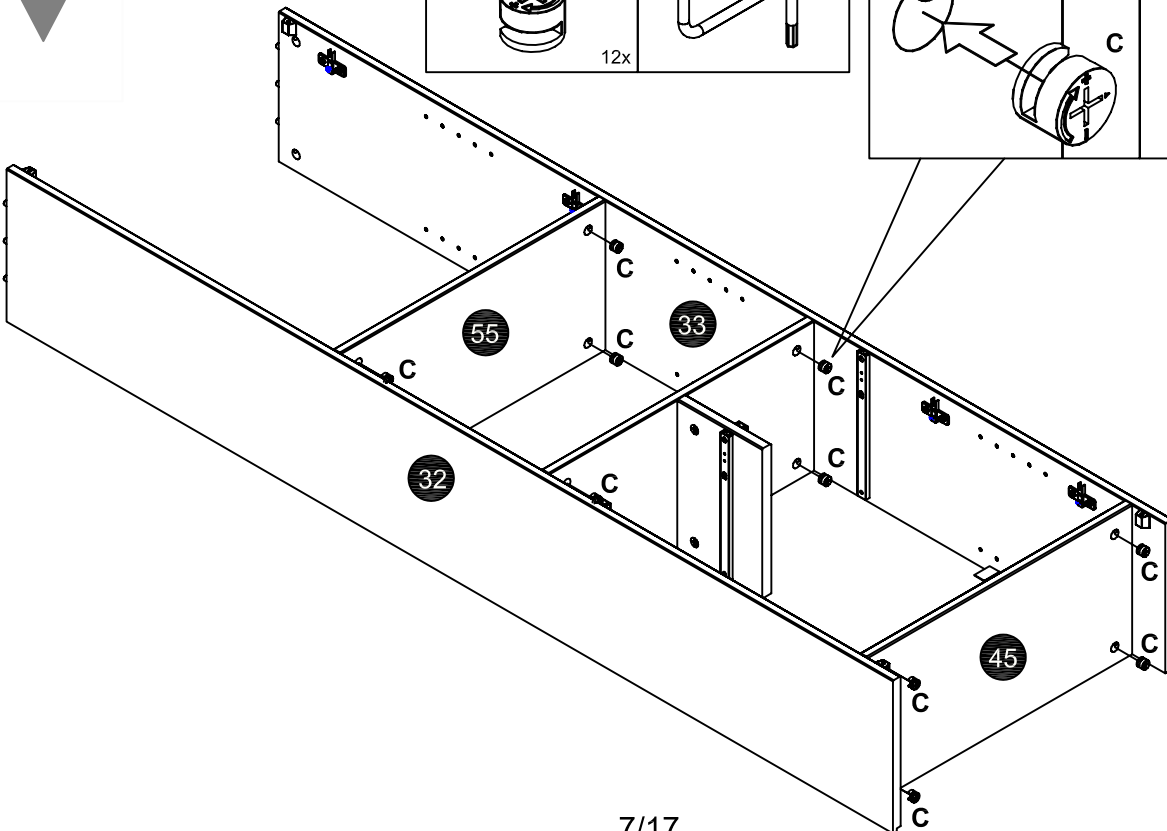
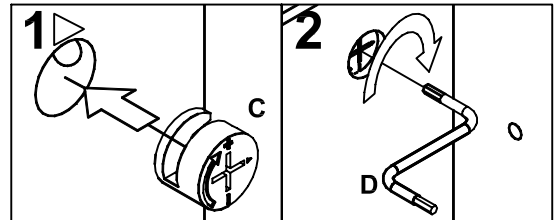
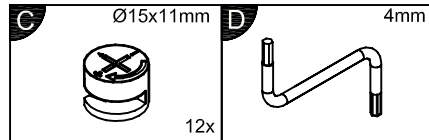

11

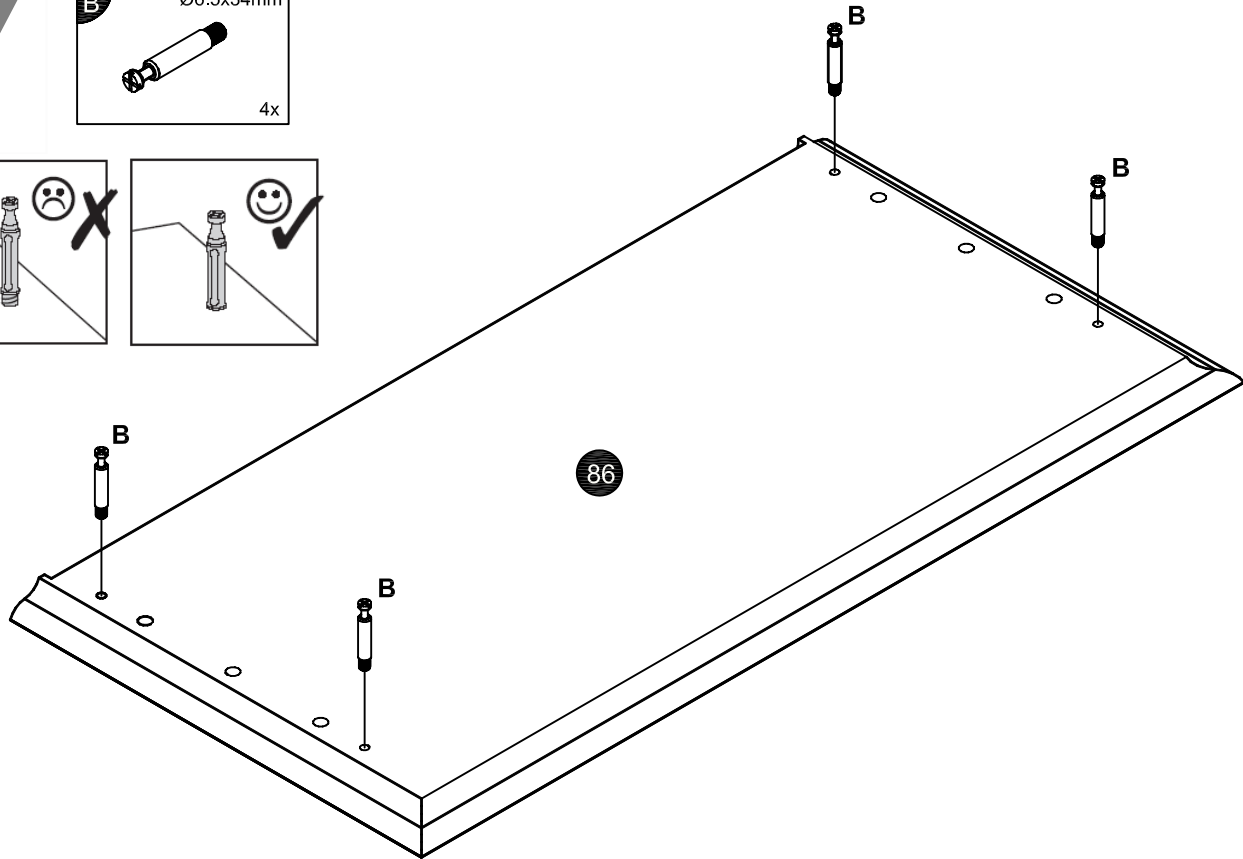
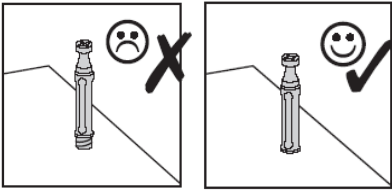
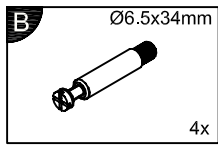

12

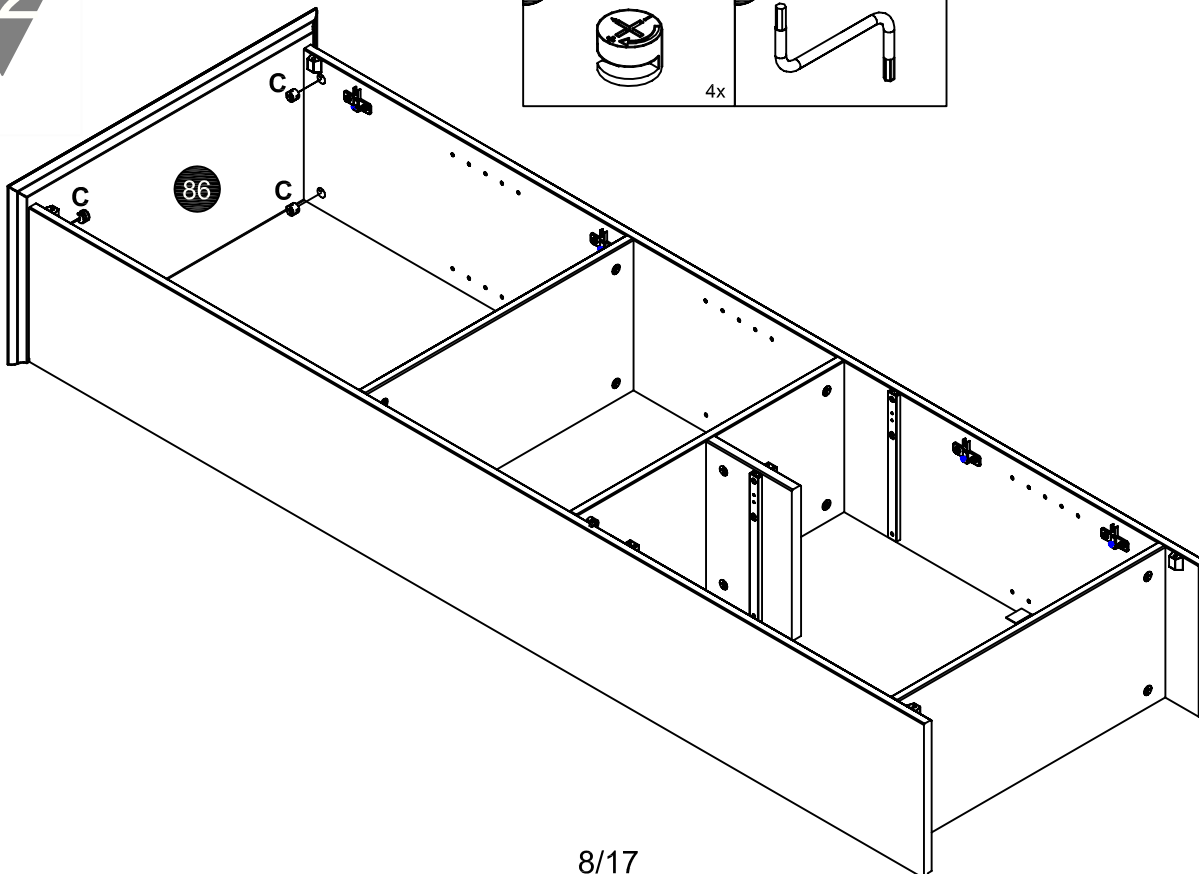
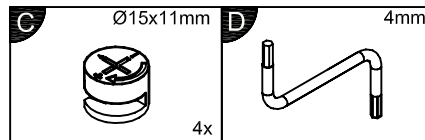

13

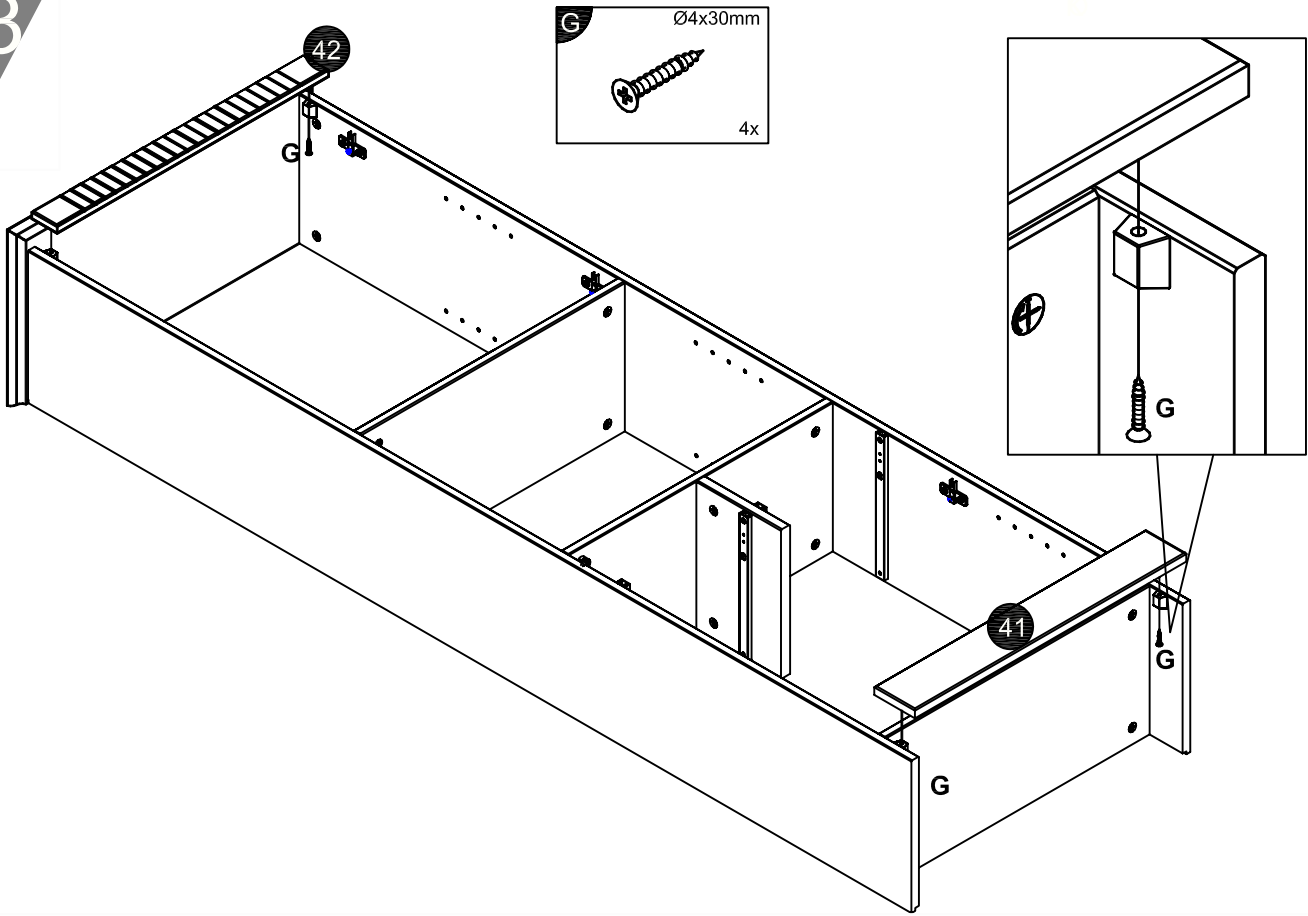

14

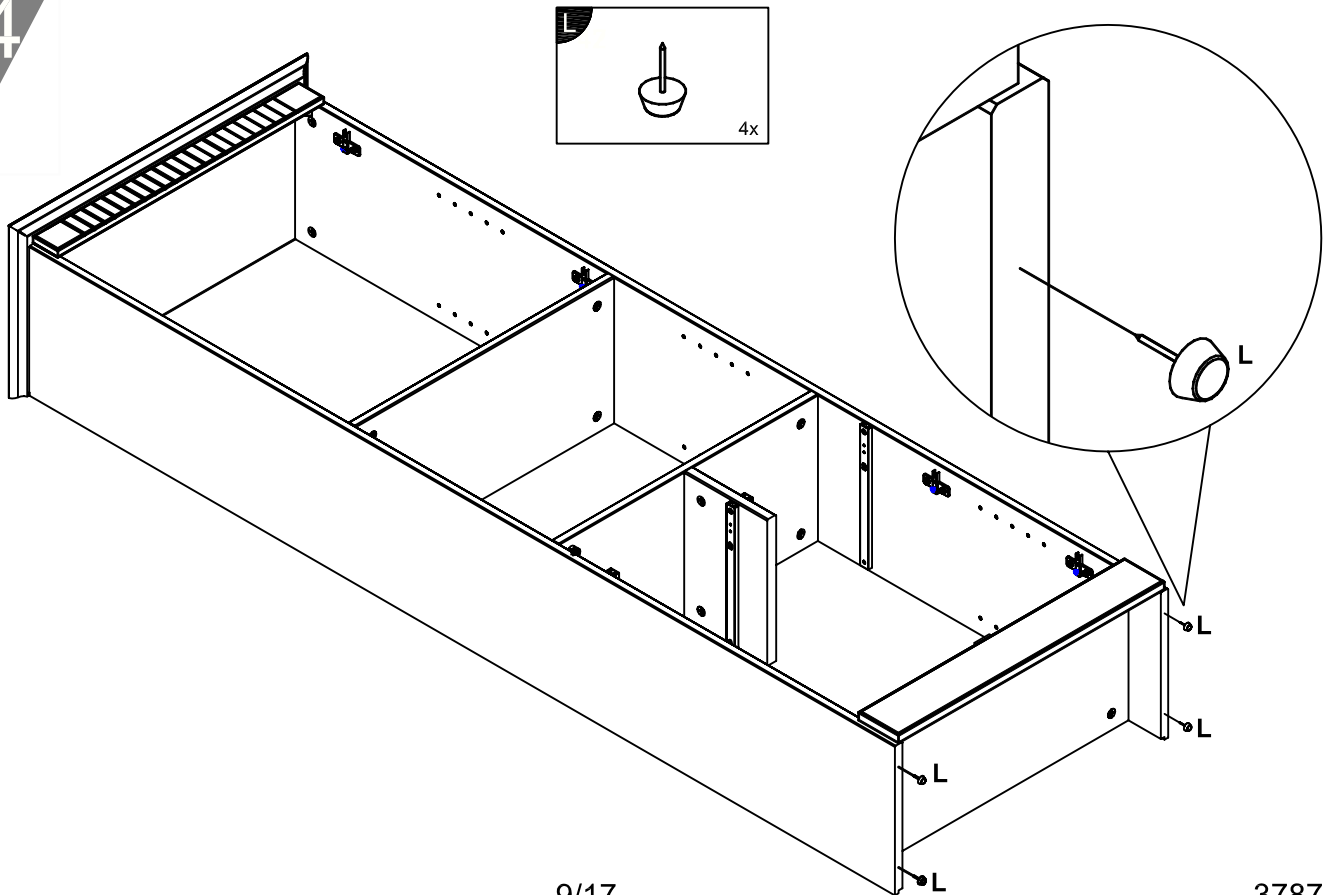

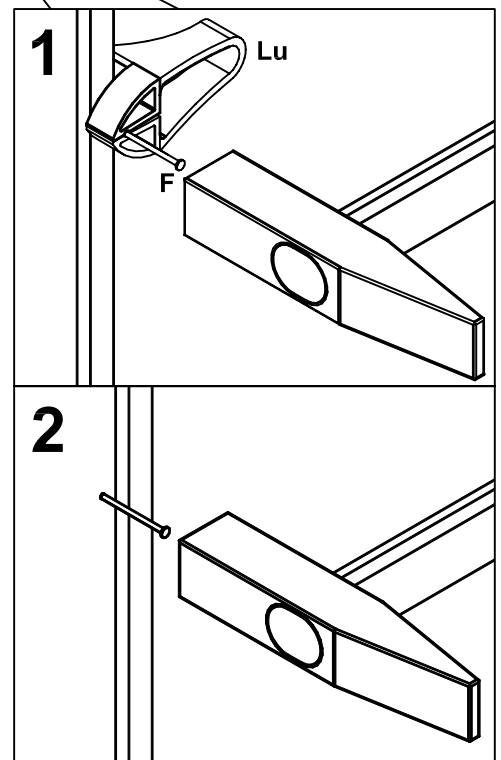
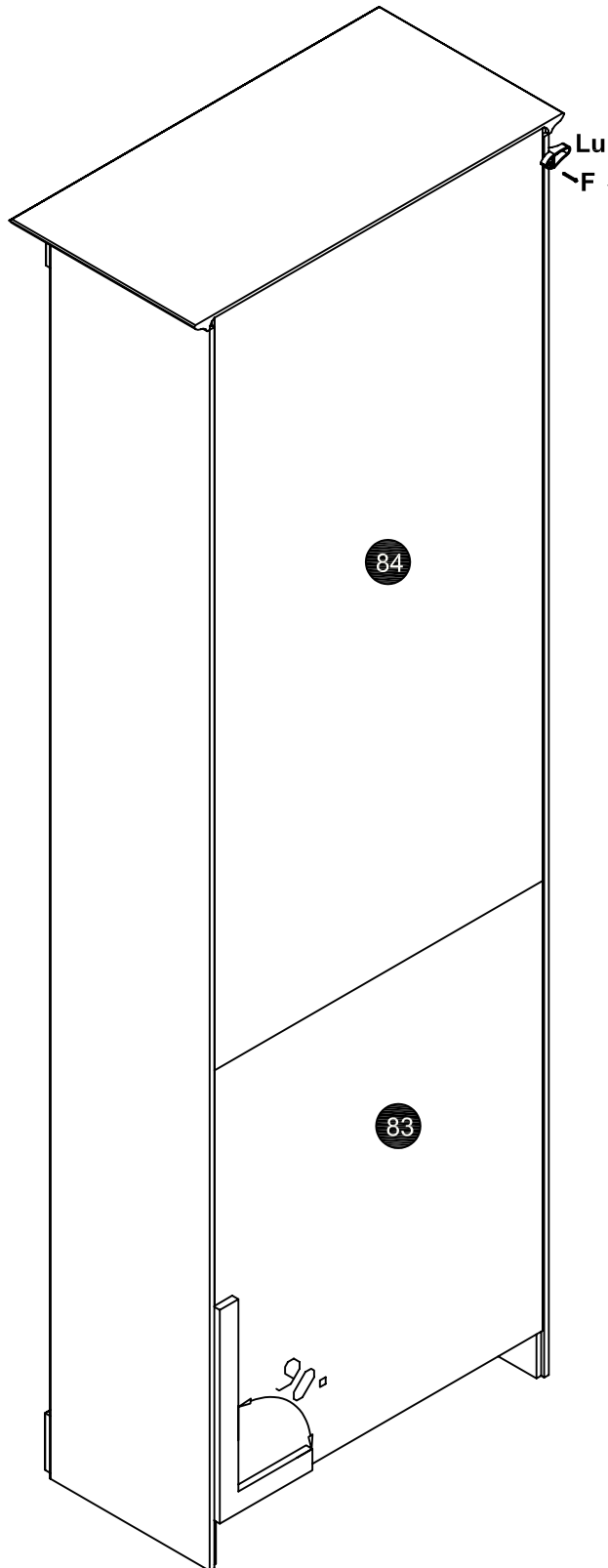
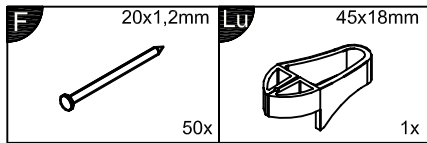

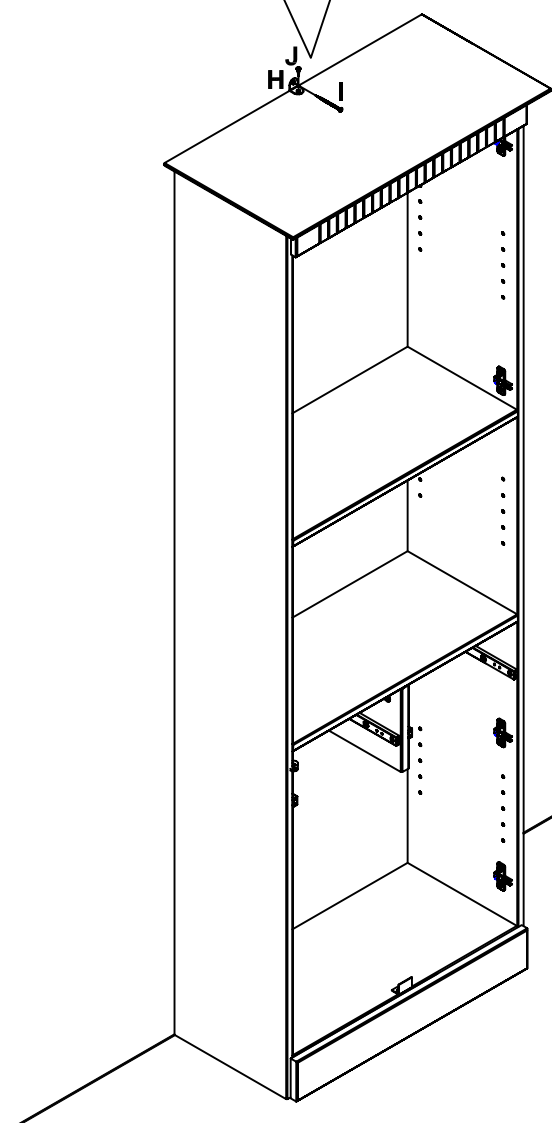
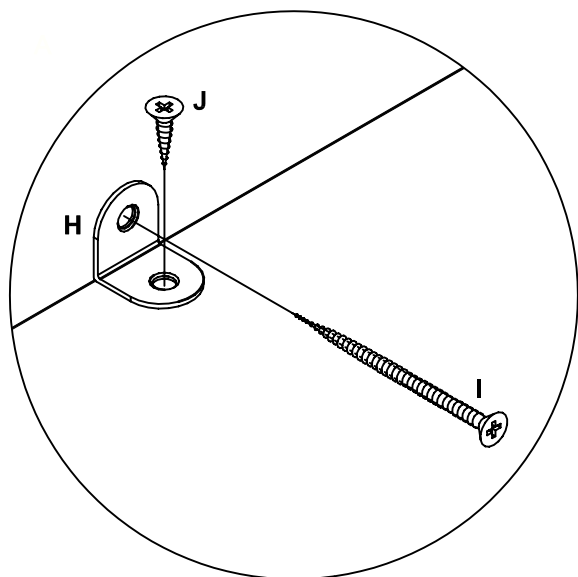
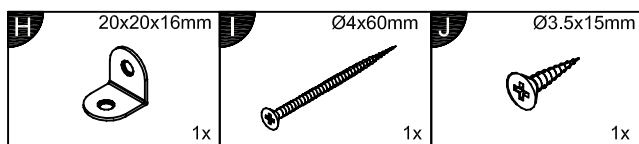

Achtung • Attention • Attenzione Opgelet • Uwaga • Pozor • Figyelem Atenție • Dikkat • Внимание	
(D)	Wandbefestigung dient als Kippschutz – unbedingt anbringen! Bei einigen Wandtypen kann ein Spezialdübel erforderlich sein!
(GB)	The wall fastening serves to prevent tipping – be absolutely sure to mount it! For certain wall types, a special wall plug may be necessary!
(FR)	La fixation murale sert de protection contre le basculement – à installer impérativement ! Pour certains types de murs il faut des chevilles spéciales !
(IT)	Il fissaggio alla parete serve da protezione anti-ribaltamento – attaccarla assolutamente! Per alcune strutture di parete può essere necessario un tassello speciale!
(NL)	Bevestiging aan de muur dient als kantelbescherming – zeker en vast bevestigen! Bij enkele muurtypes is een speciale plug misschien vereist!
(PL)	Mocowanie do ściany jest jednocześnie zabezpieczeniem przed przewróceniem – koniecznie zamontować! Do niektórych rodzajów ścian koniecznie zastosować specjalne kołki mocujące.
(CZ)	Montáž na stěnu slouží jako ochrana proti převrnutí – bezpodmínečně umístěte! U některých typů stěn může být zapotřebí speciální hmoždinka!
(SK)	Upevnenie na stenu slúži ako ochrana proti prevráteniu – bezpodmienečne použite! Pre niektoré druhy stien môže byť potrebná špeciálna hmoždinka!
(HU)	A termék a falhoz kel rögzíténi, különben az felborulhat! Egyes faltípusoknál speciális tiplit kell használni!
(RO)	Sistemul de fixare la perete servește ca protecție la răsturnare – de montat obligatoriu! Pentru unele tipuri de pereți este posibil să fie necesar un diblu special!
(TR)	Duvardaki sabitleme, devrilmeye karşı bir emniyet tedbiridir ve mutlaka monte edilmelidir! Bazı duvar tiplerinde bunun için özel bir dübel gerekli olabilir!
(RU)	Обязательно установите крепление на стене во избежание опрокидывания! Для некоторых типов стен может потребоваться специальный дюбель!

17

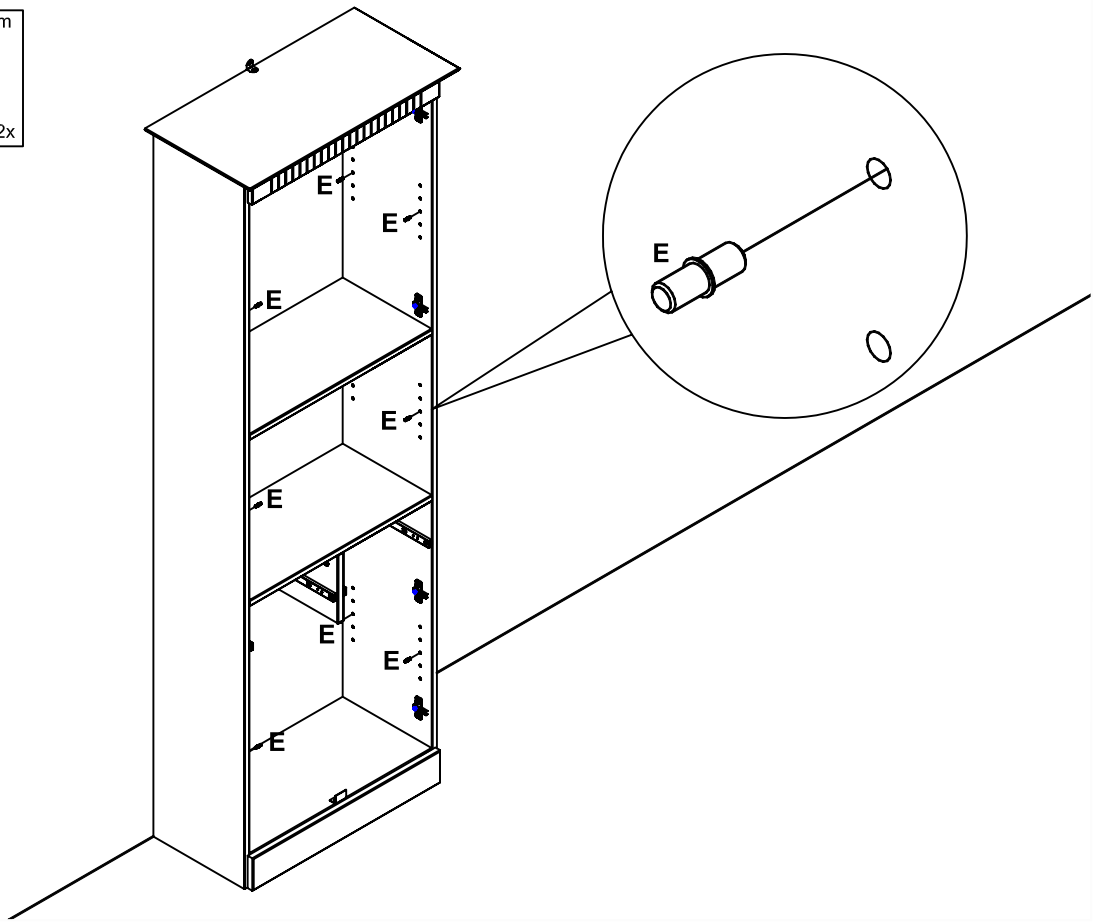
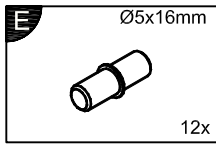

18

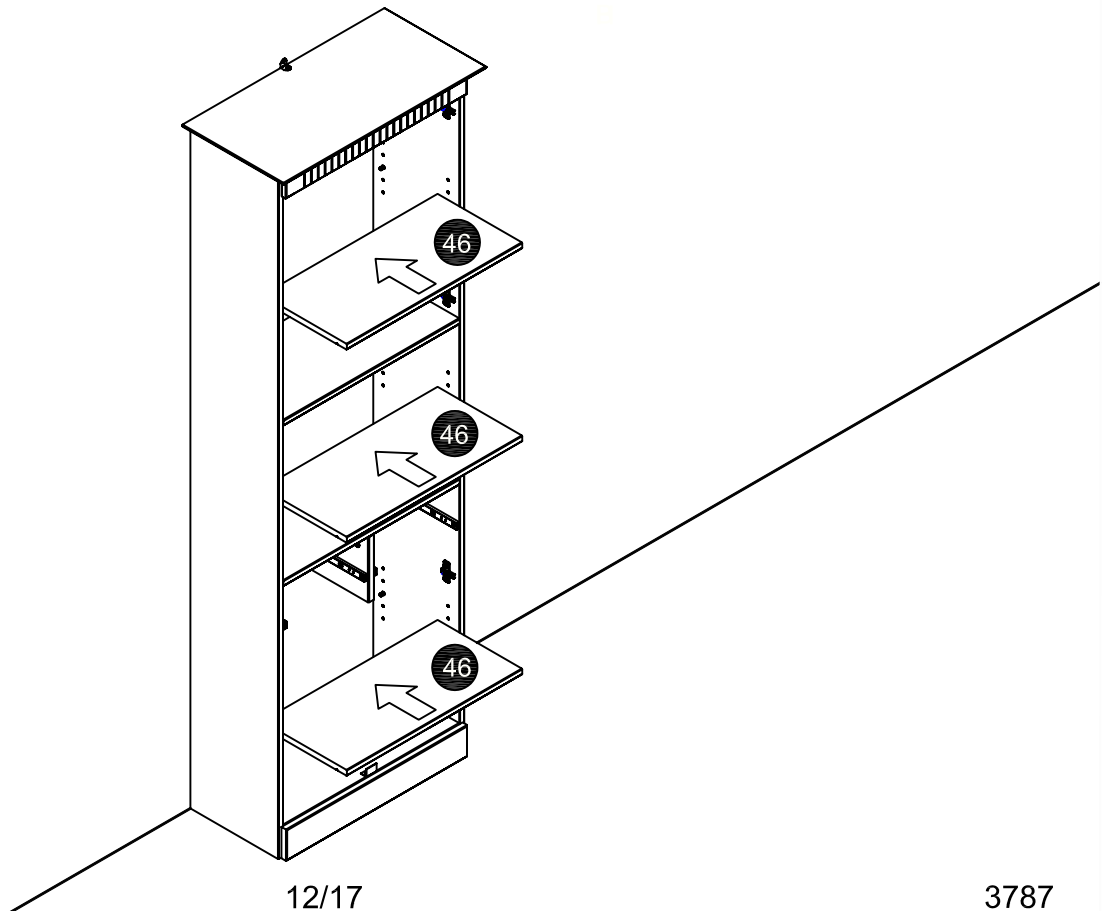

19

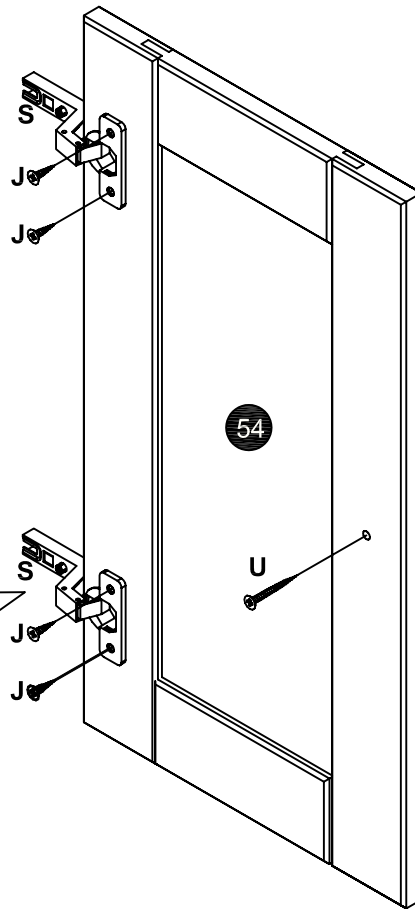
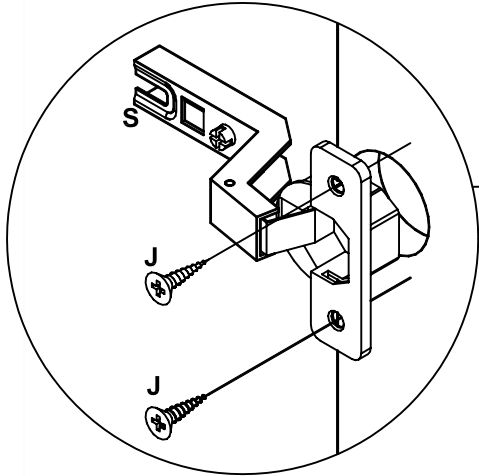
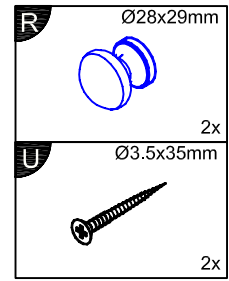
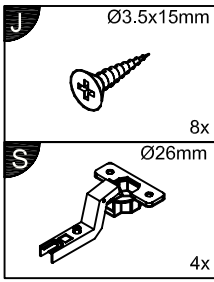

x2

20

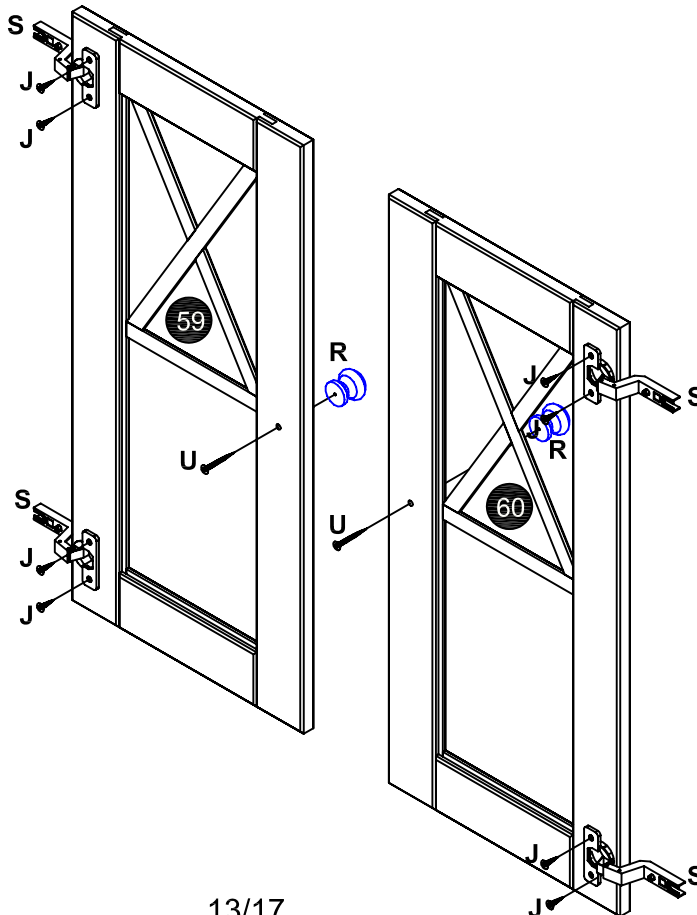
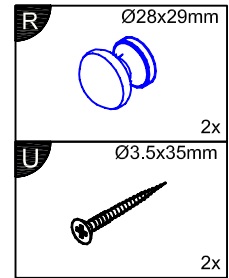
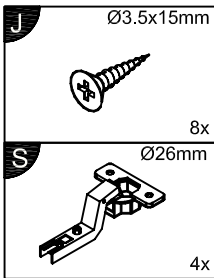

21

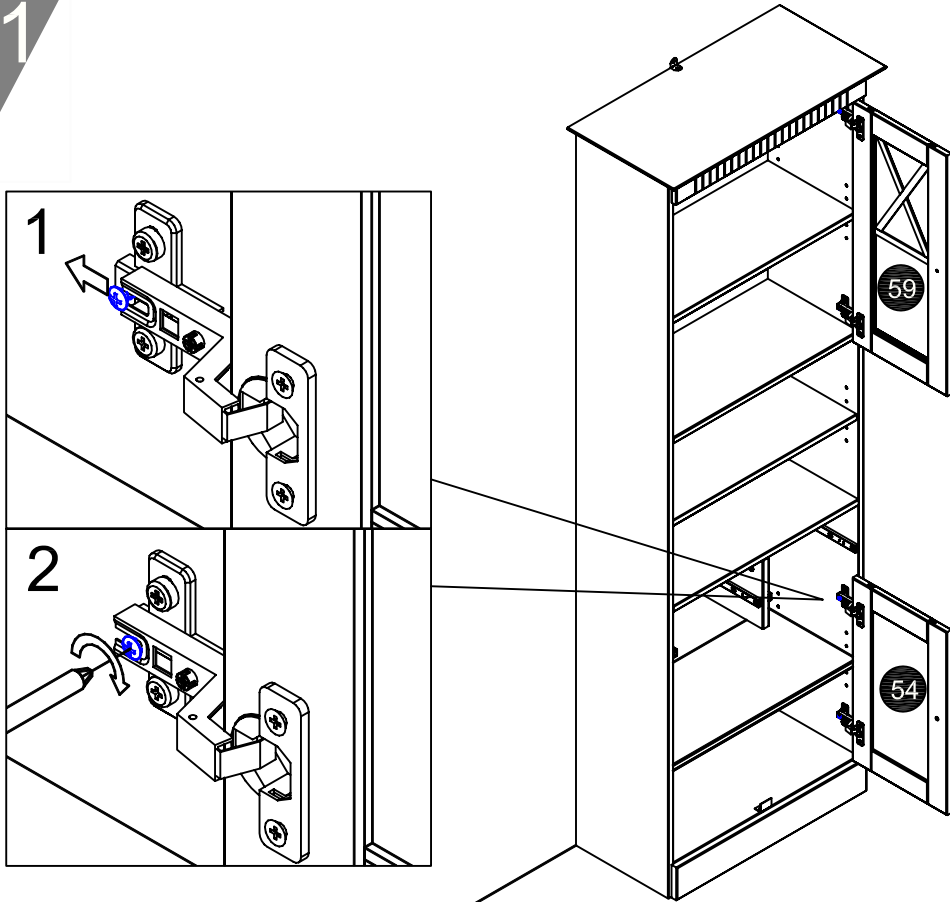

22

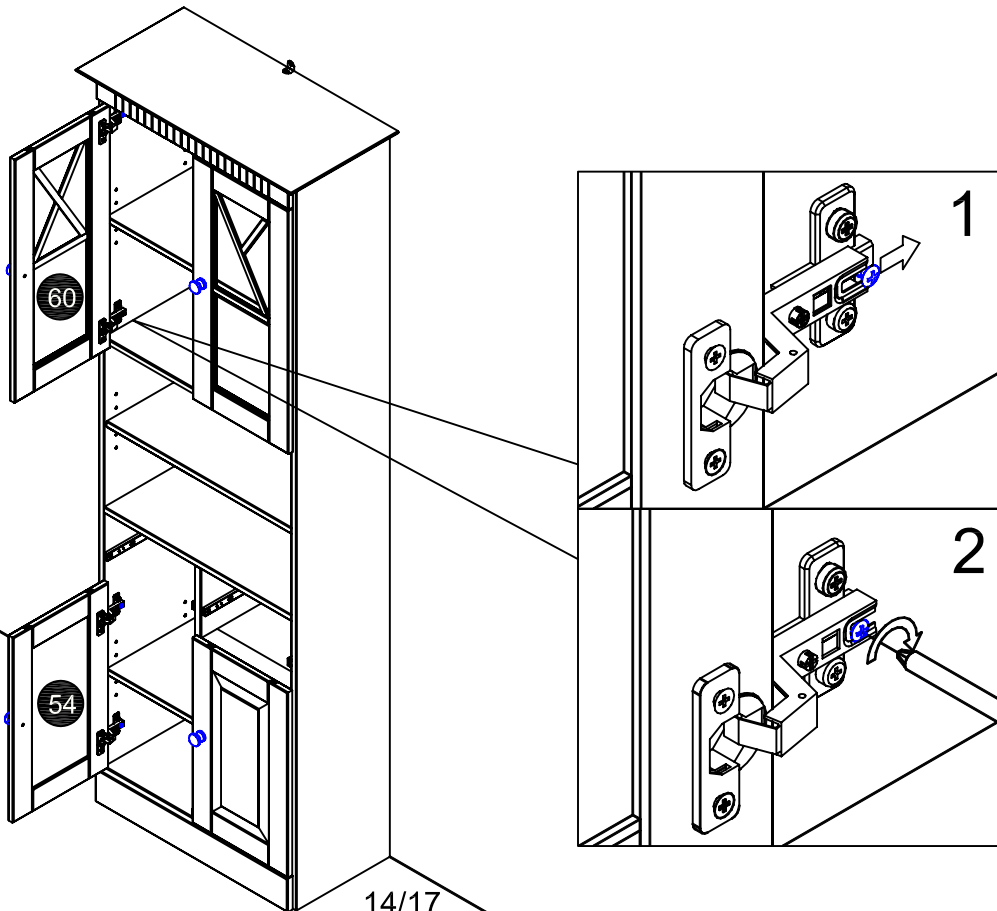

23

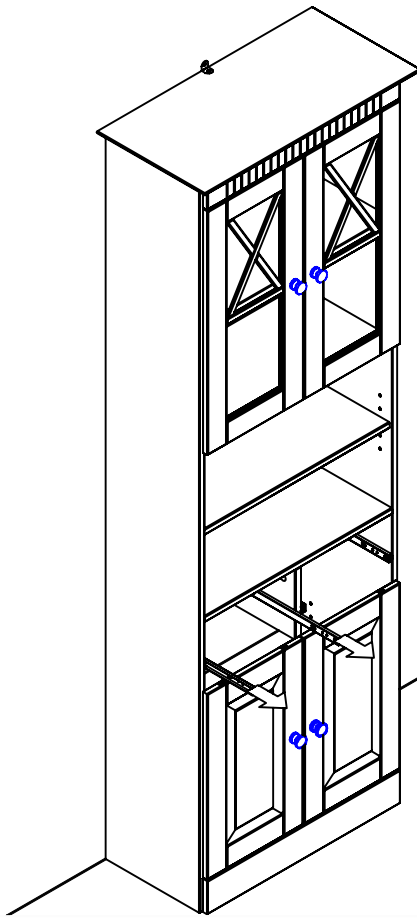

24

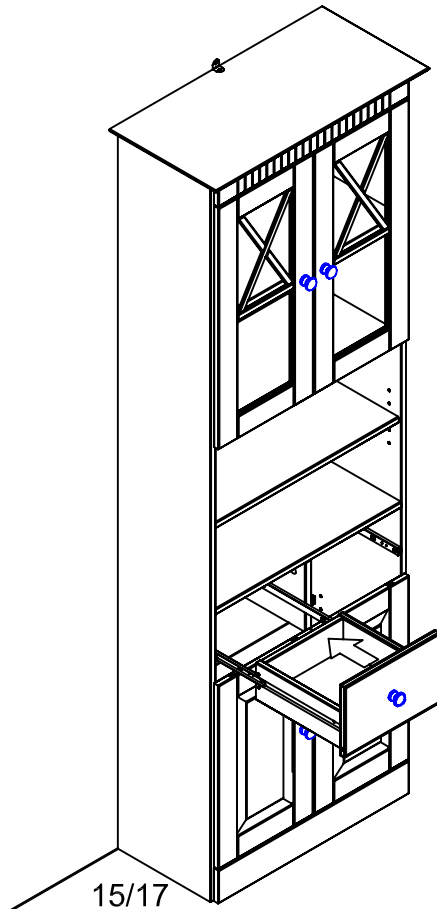

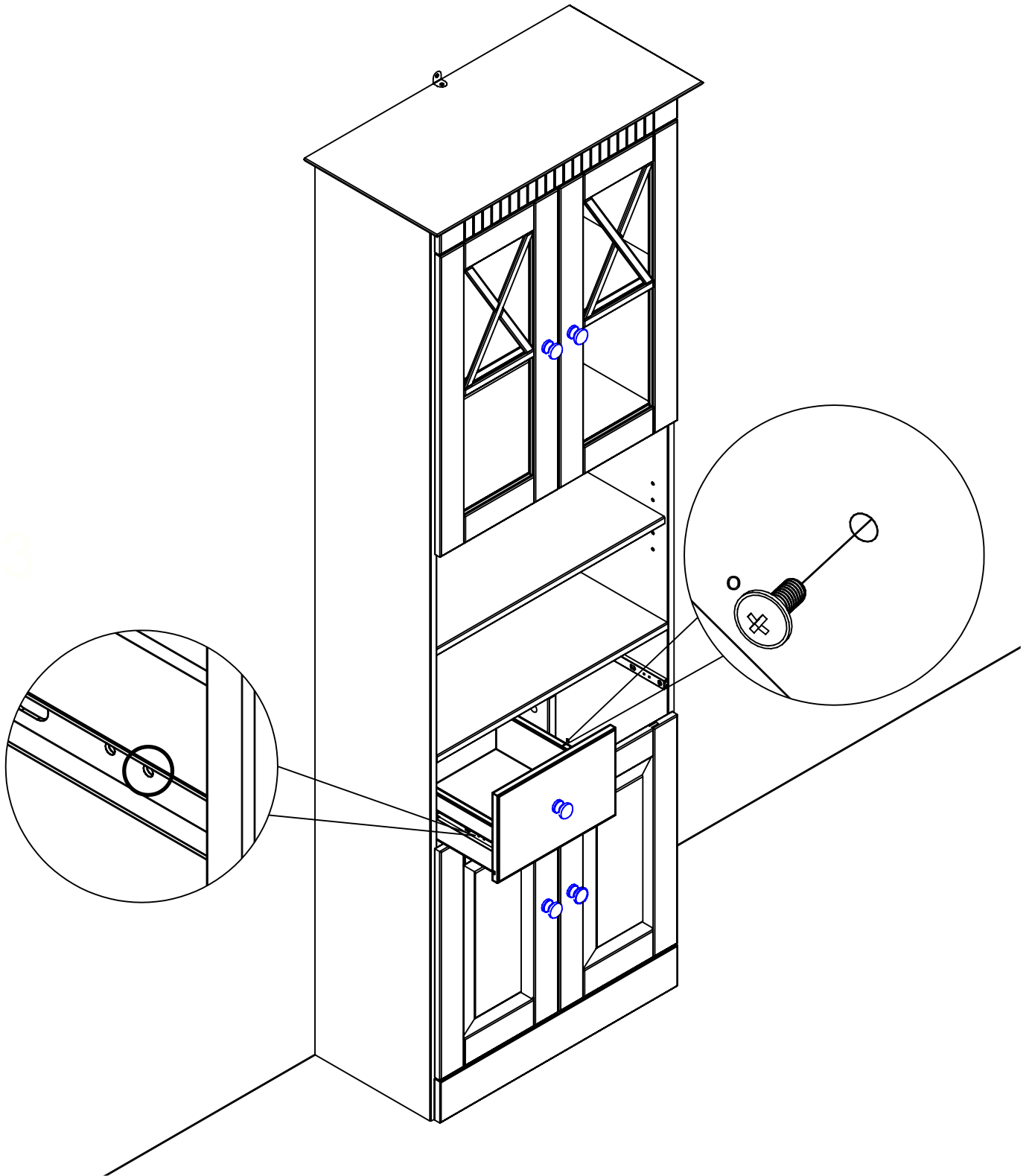
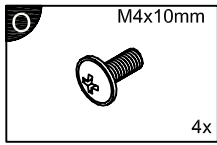

26

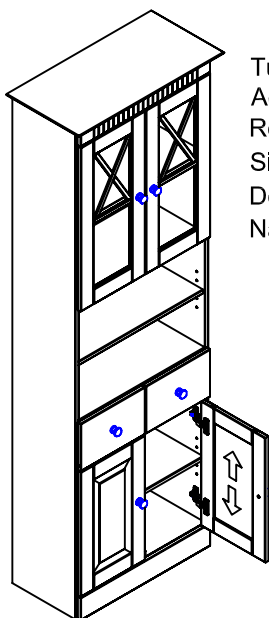

Türen einstellen (Scharniere justieren)
 Adjusting the doors (adjusting the hinges)
 Régler les portes (ajuster les charnières)
 Sistemare le porte (regolare le cerniere)
 Deuren instellen (scharnieren afstellen)
 Nastawić drzwi (wyregulować zawiasy)

Vyrovnejte dvířka (seřid'te závěsy)
 Nastavenie dverí (nastavenie závesov)
 Állítsa be az ajtókat (állítsa be a zsanérokat)
 Reglare uși (ajustare balamale)
 Kapıların ayarlanması (menteşelerin seviye ayarı)
 Регулировка дверей (регулировка шарнира)

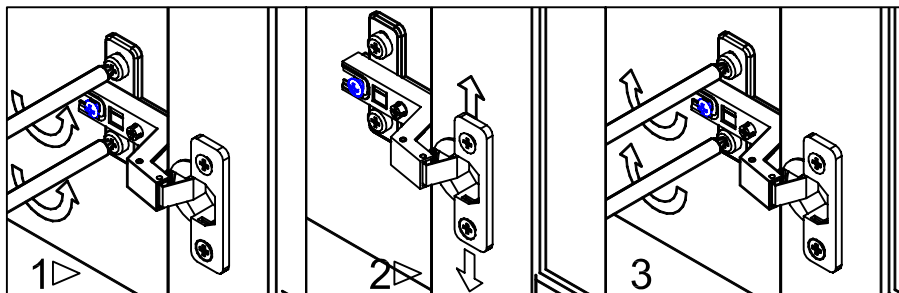

27

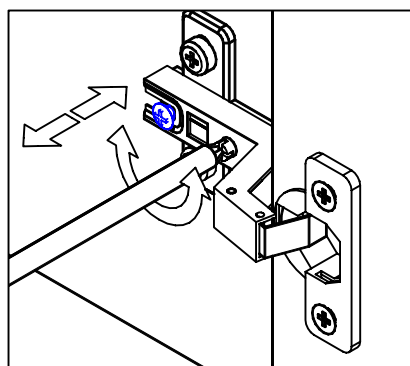
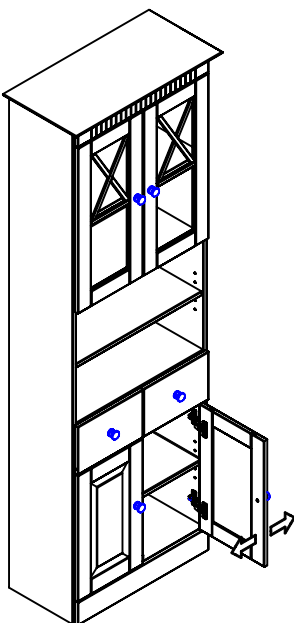

28

