

# Montageanleitung | Instructions de montage Assembly Instructions | Instrucciones de montaje

**SKU NUMBER:**  
**WF314849/WF314850**  
**WF314851/WF314852**

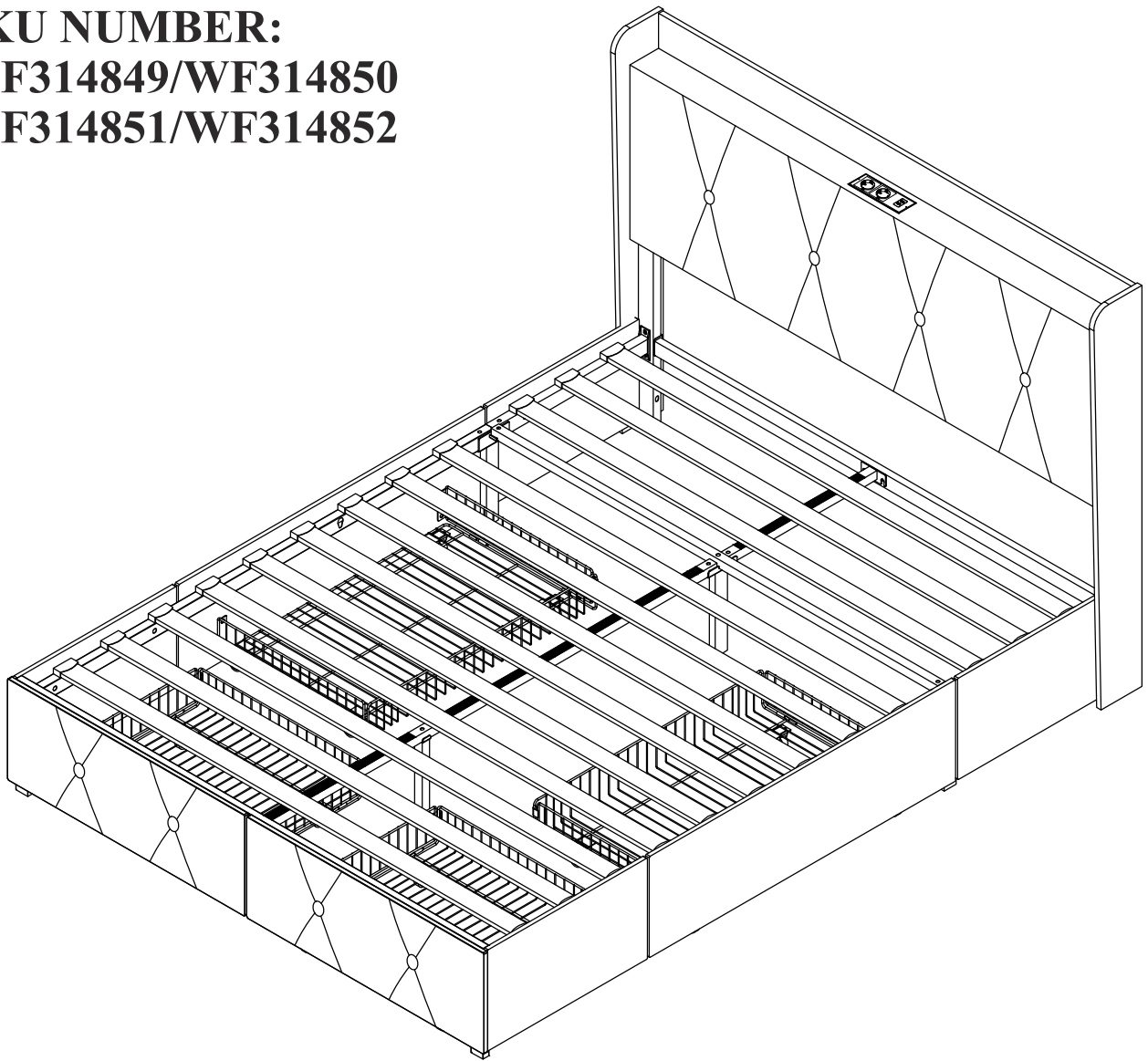

**GB** This set comes in 2 boxes. If you do not receive a full set of 2 boxes, please contact our customer service.

**DE** Dieses Set wird in 2 Schachteln geliefert. Wenn Sie nicht ein komplettes Set von 2 Boxen erhalten, kontaktieren Sie bitte unseren Kundenservice.

**FR** Ce set est livré en 2 boîtes. Si vous ne recevez pas un jeu complet de 2 boîtes, veuillez contacter notre service clientèle.

## English

### IMPORTANT ! KEEP FOR FUTURE REFERENCE : READ CAREFULLY

- To be assembled by an adult. Assembly must be checked by an adult before use
- WARNING ! Keep all screws, small parts and plastic bags out of the reach of children
- Properly identify all parts before assembling
- Never use your item if any of its parts are broken or missing
- Should any problems arise, please contact our After Sales Service
- Manufacturer's instructions shall be followed at all times
- Care: Clean with a soft, dry cloth. In case of larger stains, carefully rub with a slightly damp, non-abrasive sponge
- Do not jump on the bed

## Français

### IMPORTANT ! CONSERVER POUR RÉFÉRENCE ULTÉRIEURE : LIRE ATTENTIVEMENT

- Le montage doit être effectué par un adulte. Le montage doit être vérifié par un adulte avant utilisation
- ATTENTION ! Tenir les vis, les petites pièces et les sachets en plastique hors de portée des enfants
- Identifiez correctement toutes les pièces avant de les assembler
- N'utilisez jamais votre article si l'une de ses pièces est cassée ou manquante
- En cas de problème, veuillez contacter notre service après-vente
- Les instructions du fabricant doivent être respectées à tout moment
- Entretien : nettoyer avec un chiffon doux et sec. En cas de taches plus importantes, frotter soigneusement avec une éponge non abrasive légèrement humide. légèrement humide et non abrasive
- Ne pas sauter sur le lit

## Deutsch

### WICHTIG ! ZUM SPÄTEREN NACHSCHLAGEN AUFBEWAHREN: SORGFÄLTIG LESEN

- Muss von einem Erwachsenen zusammengebaut werden. Der Zusammenbau muss vor dem Gebrauch von einem Erwachsenen überprüft werden
- WARNUNG! Bewahren Sie alle Schrauben, Kleinteile und Plastikbeutel außerhalb der Reichweite von Kindern auf
- Kennzeichnen Sie vor dem Zusammenbau alle Teile richtig.
- Benutzen Sie Ihren Artikel niemals, wenn Teile gebrochen sind oder fehlen
- Sollten Probleme auftreten, wenden Sie sich bitte an unseren Kundendienst
- Die Anweisungen des Herstellers sind stets zu befolgen
- Pflege: Mit einem weichen, trockenen Tuch reinigen. Bei größeren Flecken vorsichtig mit einem leicht feuchten, nicht scheuernden Schwamm abreiben. nicht scheuernden Schwamm
- Nicht auf das Bett springen



## More Tips



**English** - Before installation, you can place the parts on a carpet or other soft fabric, in order to avoid damaging your floor.

**Français** - Avant l'installation, vous pouvez placer les pièces sur un tapis ou un autre tissu doux, afin d'éviter d'endommager votre sol.

**Deutsch** - Vor der Installation können Sie die Teile auf einen Teppich oder ein anderes weiches Material legen, um eine Beschädigung Ihres Fußbodens zu vermeiden.

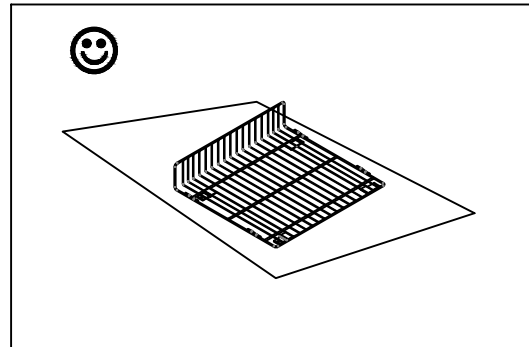
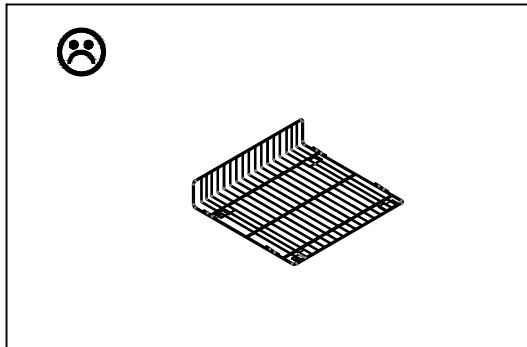

**English** - For your and your family's safety, please do not jump on beds, especially with hydraulic structures. When need to move bed, please work with more than one person to lift, not push, to avoid scratching your floor and hurting the stability of the bed.



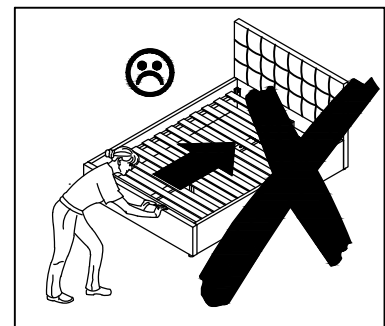
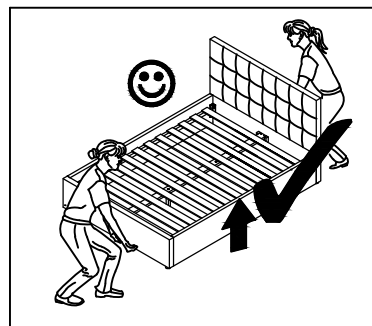
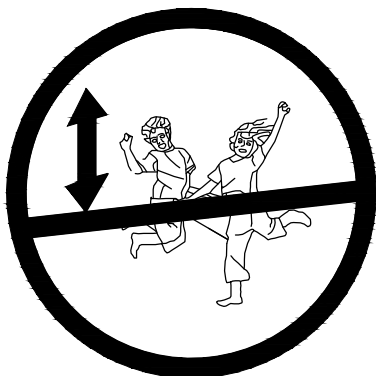

**Français** - Pour votre sécurité et celle de votre famille, ne sautez pas sur les lits, en particulier sur les structures hydrauliques. Lorsqu'il est nécessaire de déplacer le lit, il est préférable de travailler à plusieurs pour le soulever, et non pour le pousser, afin d'éviter de rayer le sol et de nuire à la stabilité du lit.

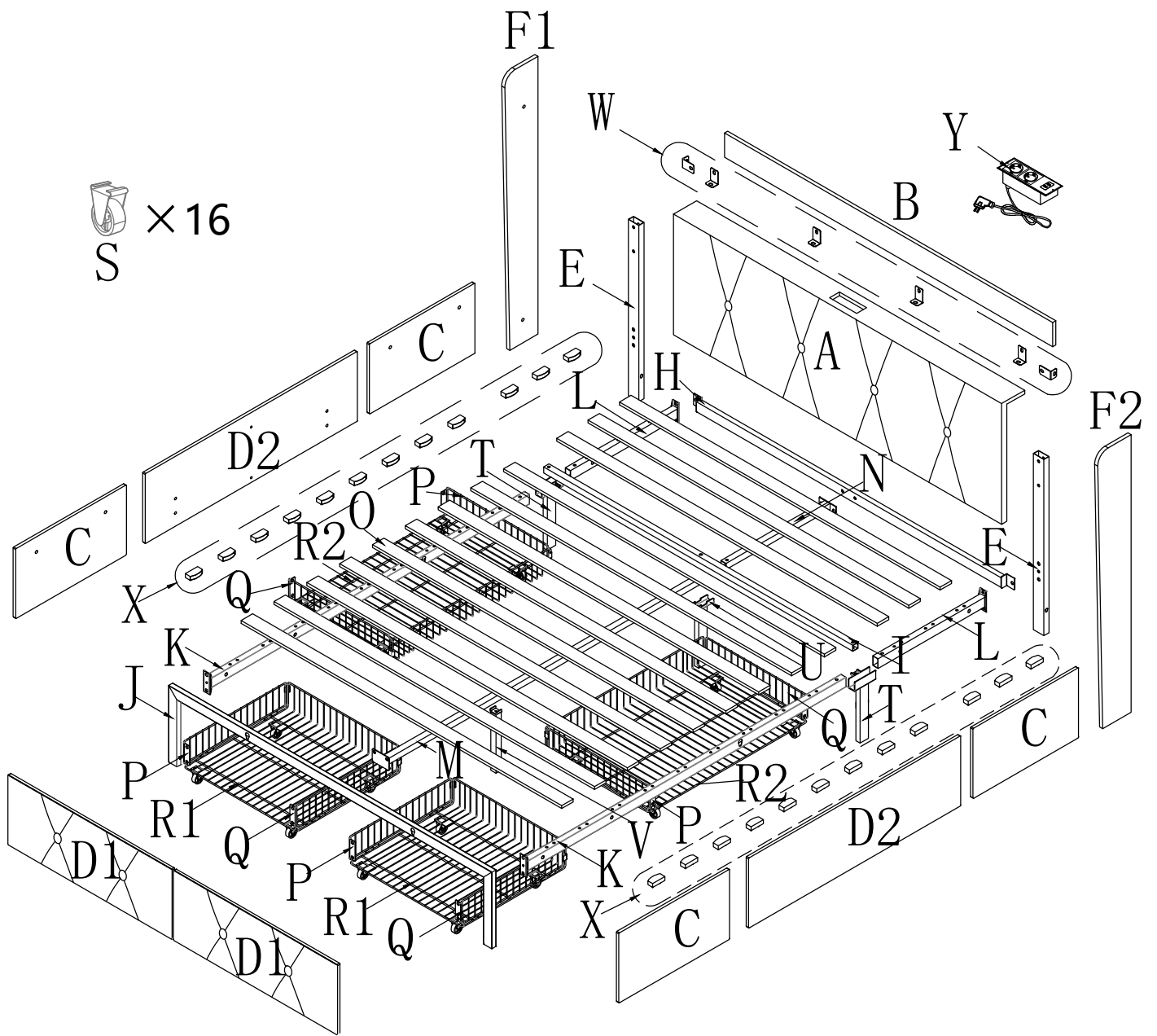
**Deutsch** - Zu Ihrer Sicherheit und der Ihrer Familie sollten Sie nicht auf Betten springen, insbesondere bei hydraulischen Konstruktionen. Wenn Sie das Bett bewegen müssen, heben Sie es bitte mit mehreren Personen an und schieben Sie es nicht, um den Boden nicht zu verkratzen und die Stabilität des Bettes nicht zu beeinträchtigen.



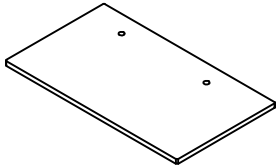
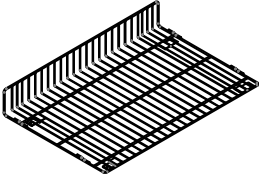
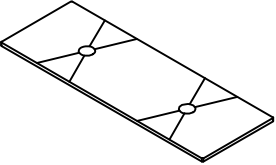

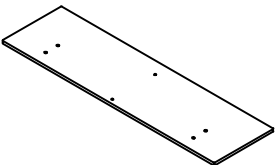
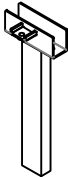
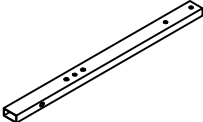
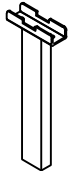
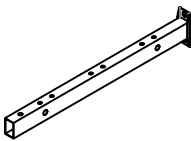

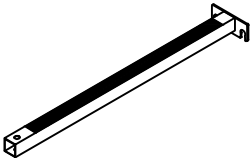
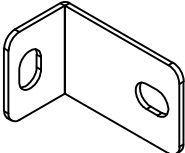
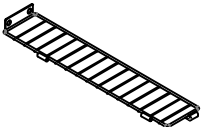
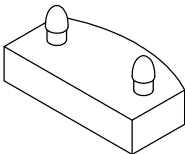
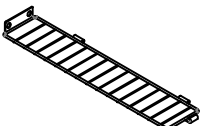
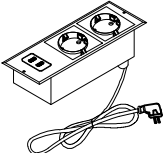
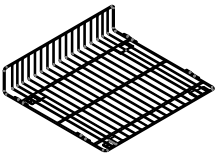



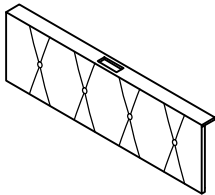
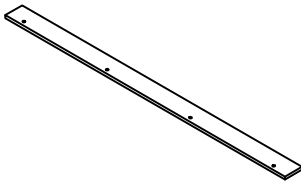

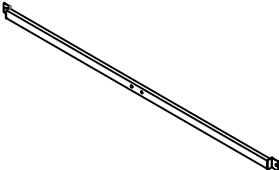
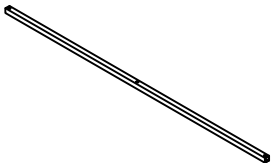
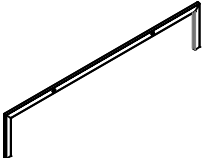

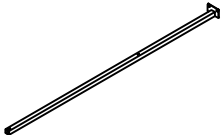
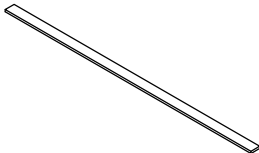

# WF314850/52AAG

<b>C</b>		X4	<b>R2</b>		X2
<b>D1</b>		X2	<b>S</b>		X16
<b>D2</b>		X2	<b>T</b>		X2
<b>E</b>		X2	<b>U</b>		X1
<b>L</b>		X2	<b>V</b>		X1
<b>N</b>		X1	<b>W</b>		X6
<b>P</b>		X4	<b>X</b>		X24
<b>Q</b>		X4	<b>Y</b>		X1
<b>R1</b>		X2			

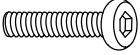
# WF314849/51AAG

<b>A</b>		X1	<b>B</b>		X1
<b>F1</b>		X1	<b>F2</b>		X1
<b>H</b>		X1	<b>I</b>		X1
<b>J</b>		X1	<b>K</b>		X2
<b>M</b>		X1	<b>O</b>		X12

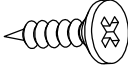
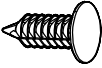
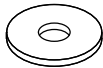
# WF314850/52AAG

<b>Z1</b>	 M8*70MM	X2	<b>Z2</b>	 M8*50MM	X11	<b>Z3</b>	 M8*40MM	X13
<b>Z4</b>	 M8*27MM	X4	<b>Z5</b>	 M8*18MM	X20	<b>Z6</b>	 M8*12MM	X8
<b>Z7</b>	 M3*16MM	X2	<b>Z8</b>	 M8*16MM	X16	<b>Z9</b>	 Ø8.5 x Ø22mm	X14
<b>Z10</b>	 M8*14MM	X16	<b>Z11</b>	 M8*16MM	X1			

**1**

Z2\*4PCS



Z5\*2PCS



Z9\*4PCS

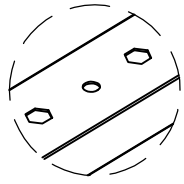

✗

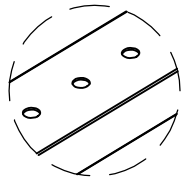

✓

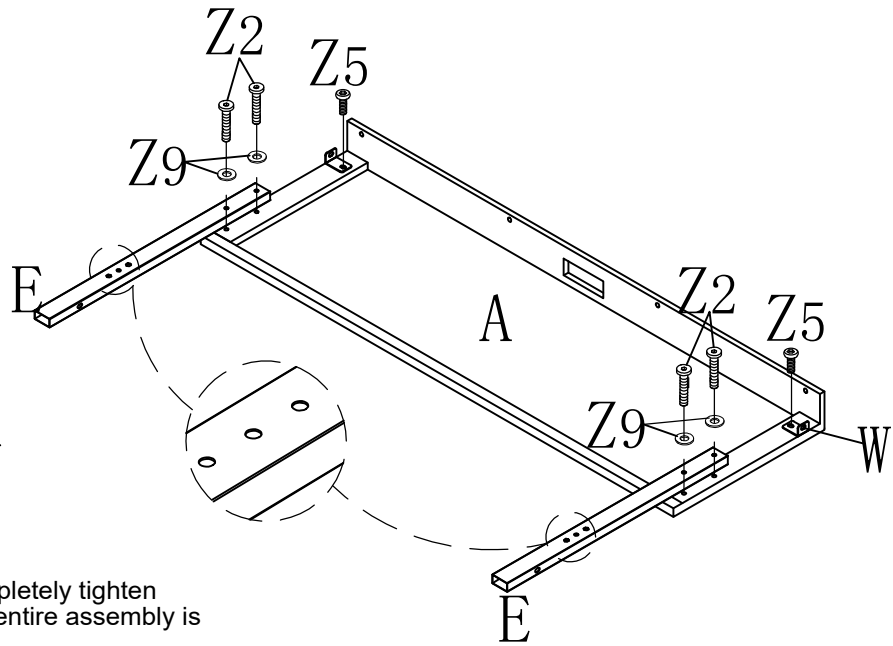

NOTE: Please do not completely tighten all the hardware until the entire assembly is complete!

HINWEIS: Ziehen Sie bitte erst dann alle Teile fest, wenn die gesamte Montage abgeschlossen ist!

REMARQUE : Ne serrez pas complètement toutes les vis avant d'avoir terminé l'assemblage !

**2**

Z5\*4PCS

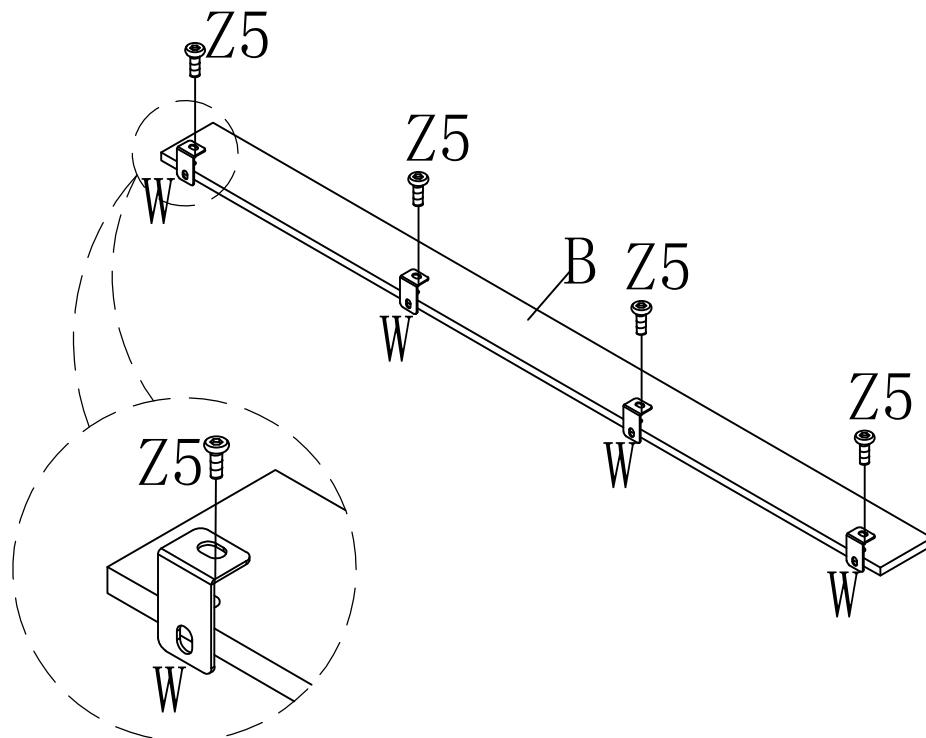

3



Z5\*4PCS

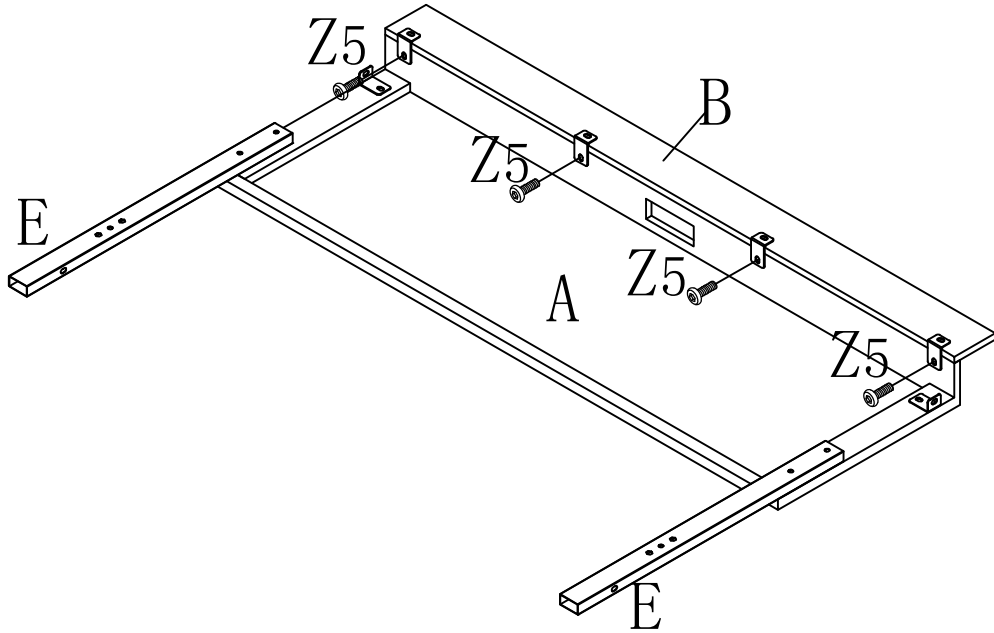

4



Z2\*4PCS

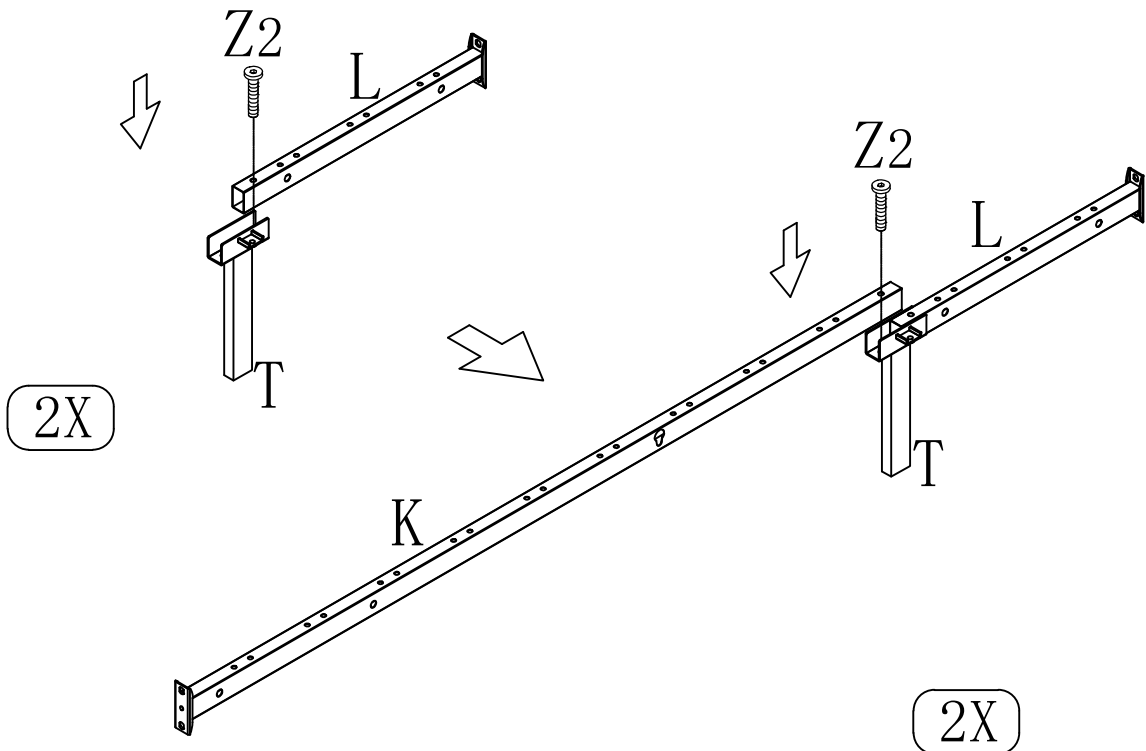



**5**

Z5\*4PCS

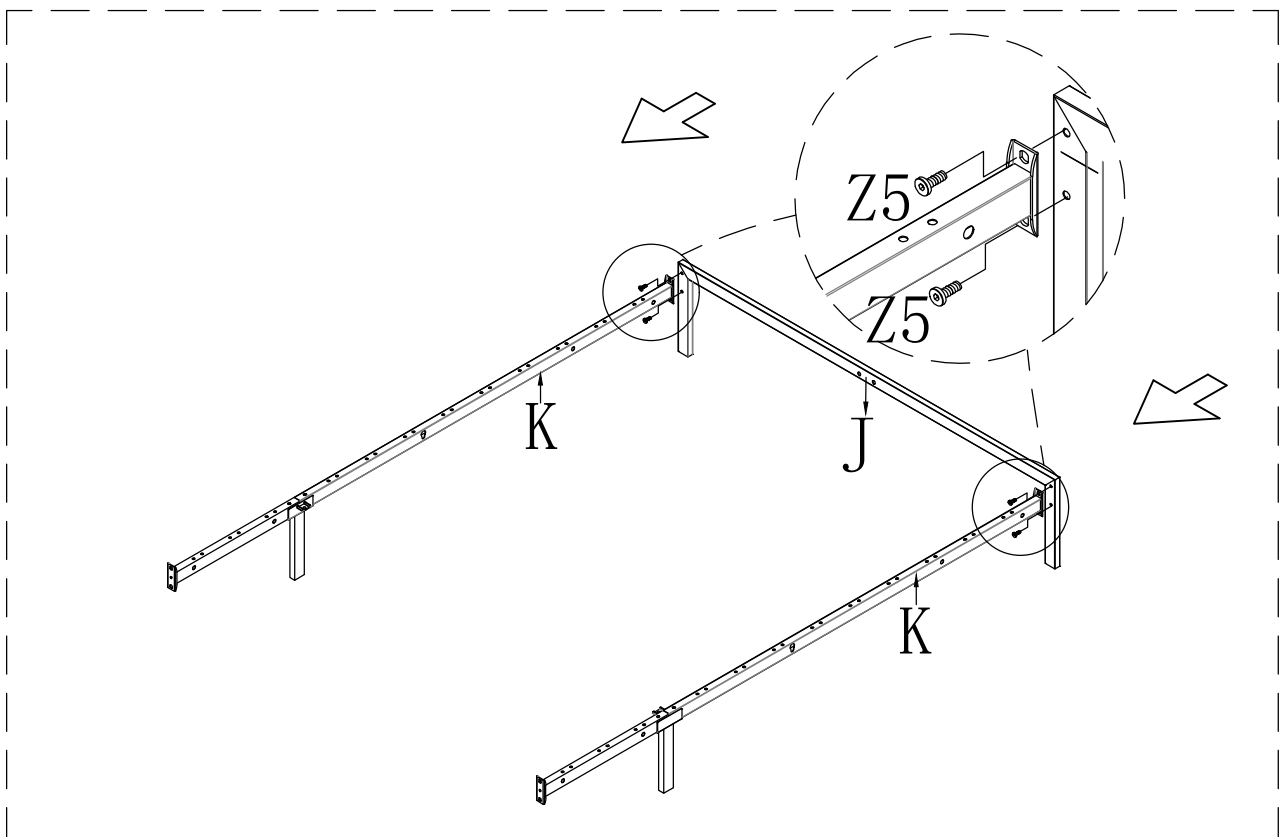
**6**

Z4\*4PCS

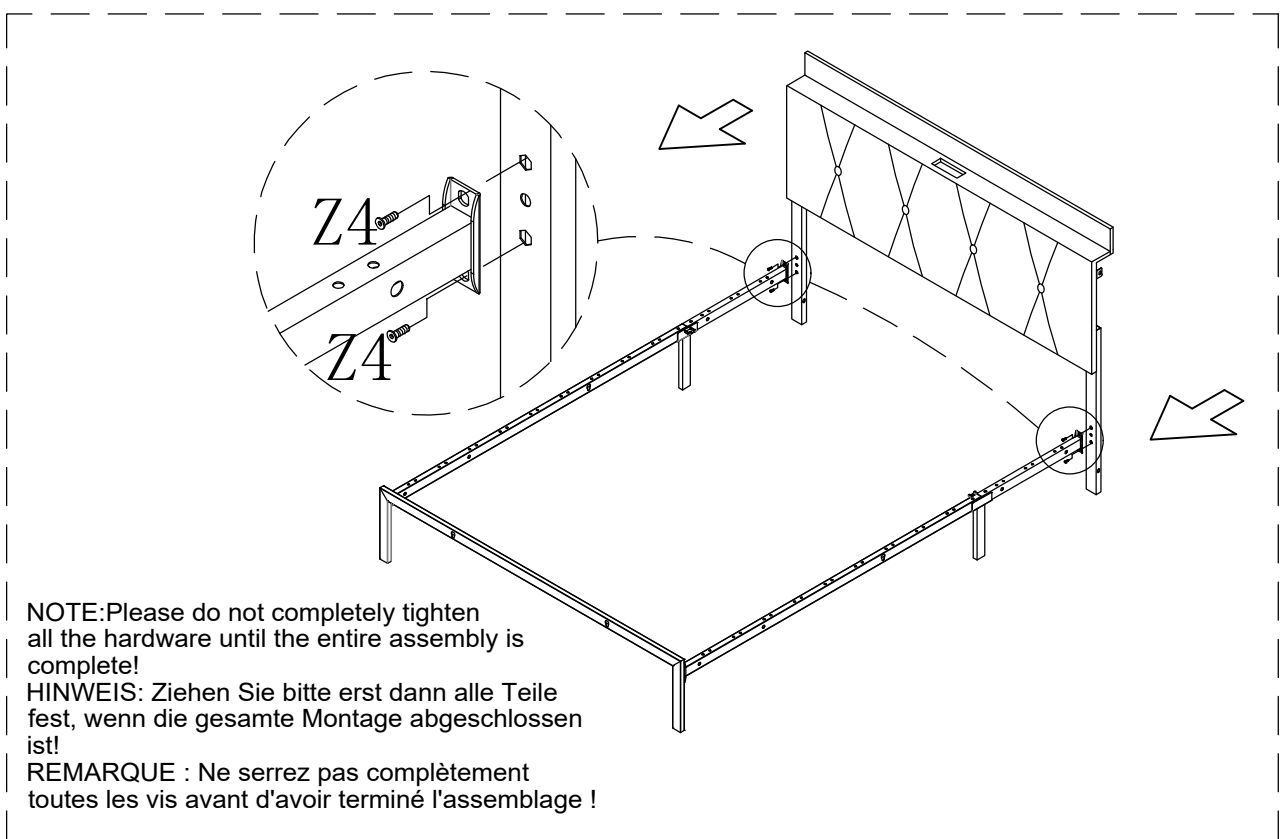

7



Z2\*2PCS



Z9\*2PCS

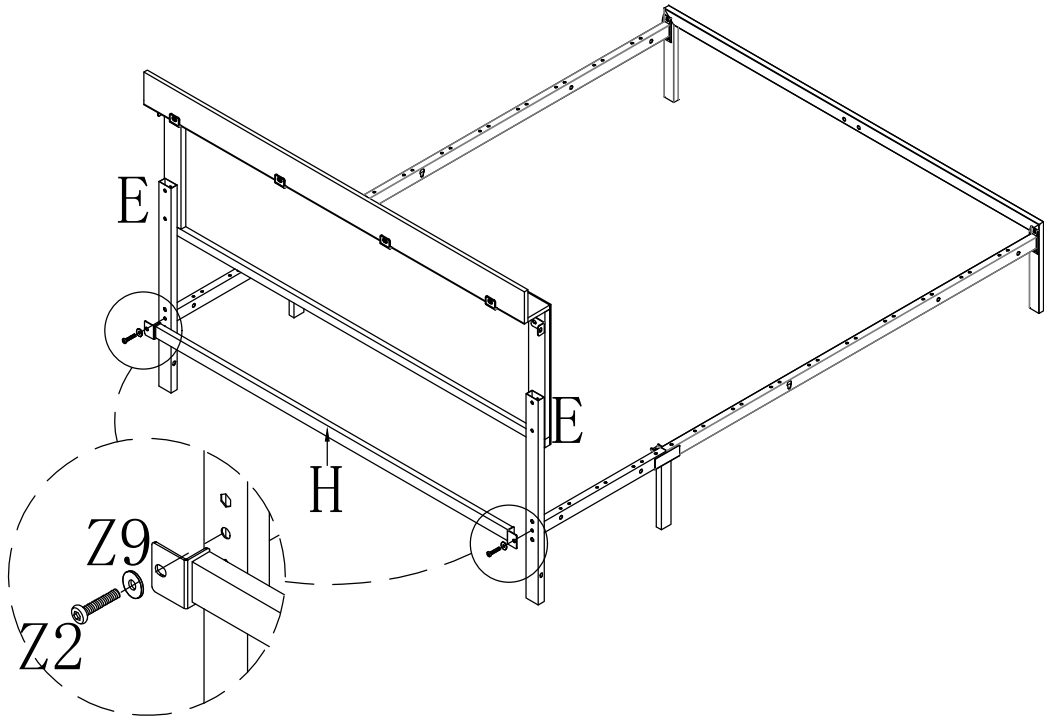

8



Z2\*1PC



Z3\*2PCS

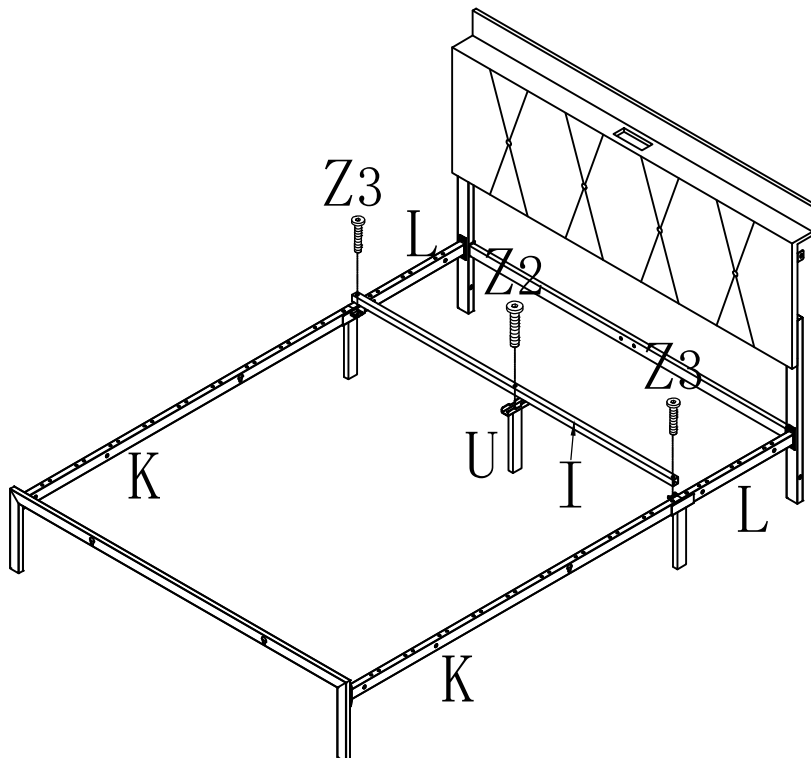

9



Z3\*3PCS

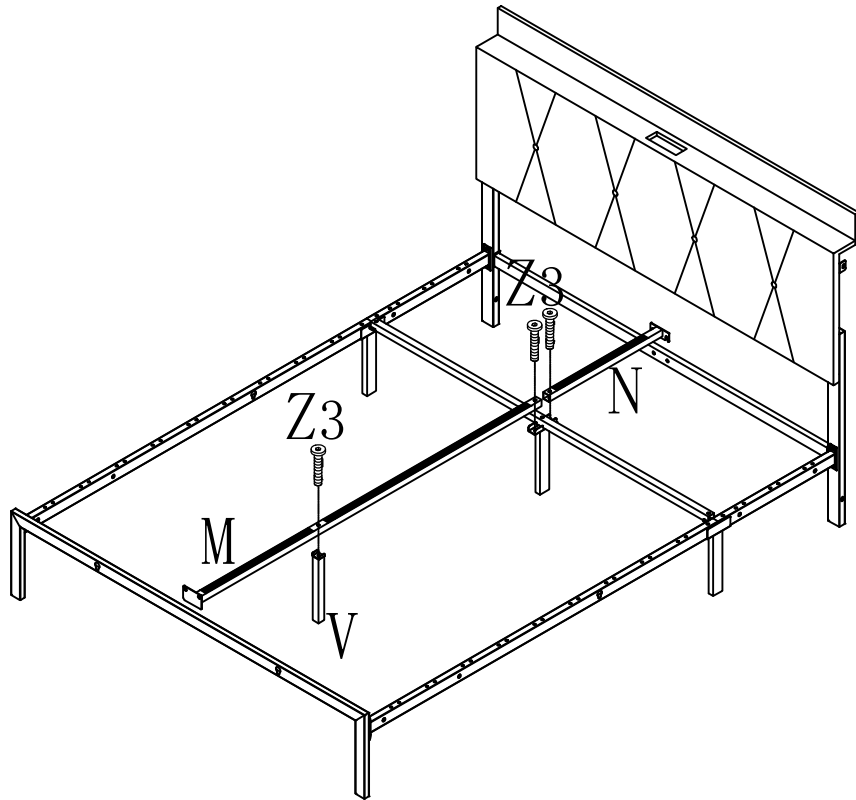

10



Z5\*4PCS

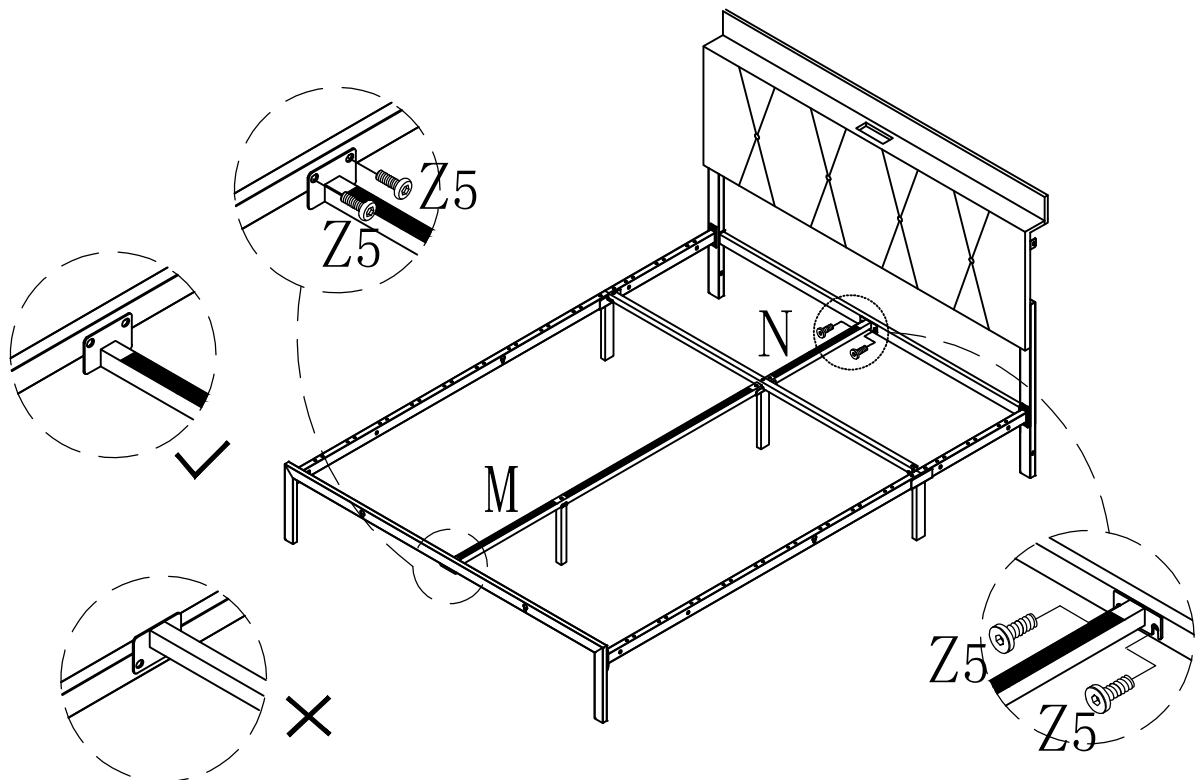

11



Z3\*8PCS

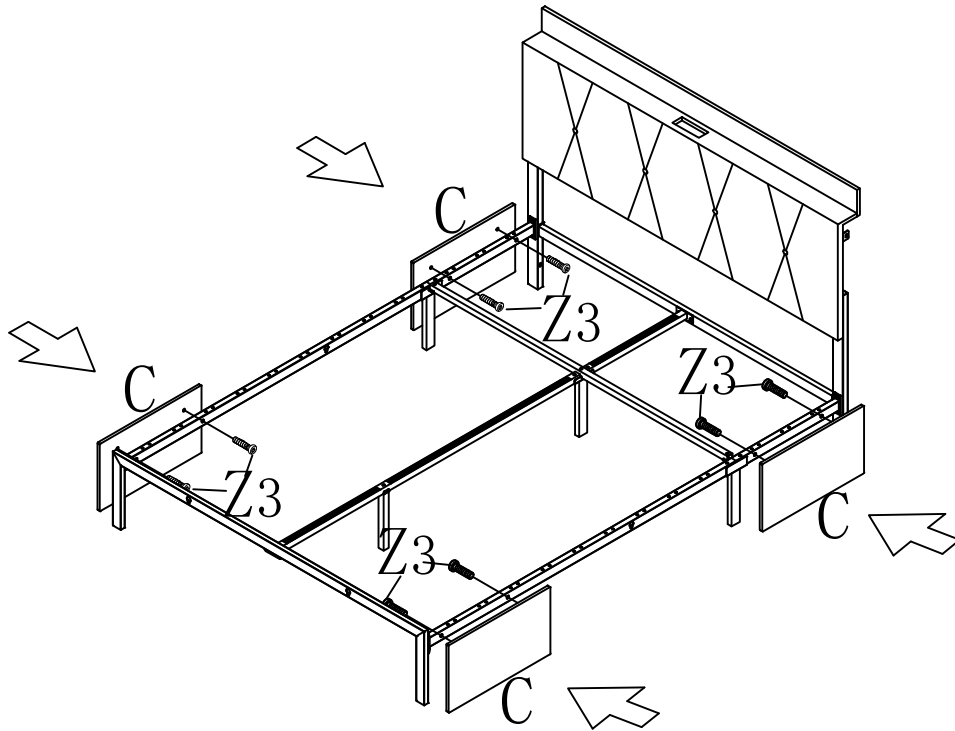

12



Z5\*2PCS

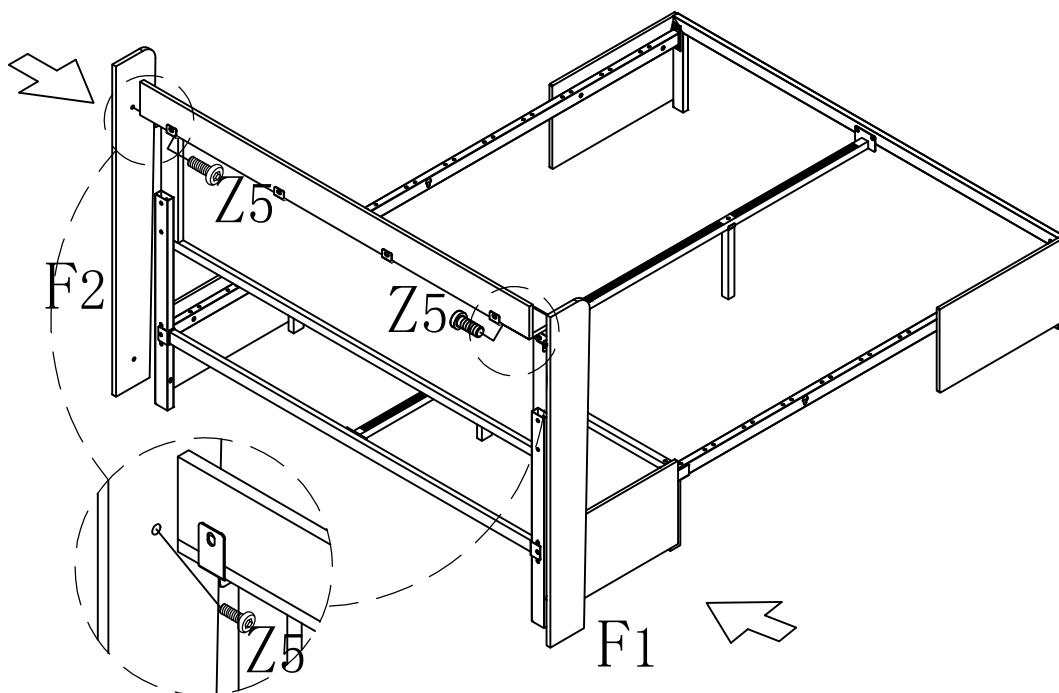

# 13



Z1\*2PCS

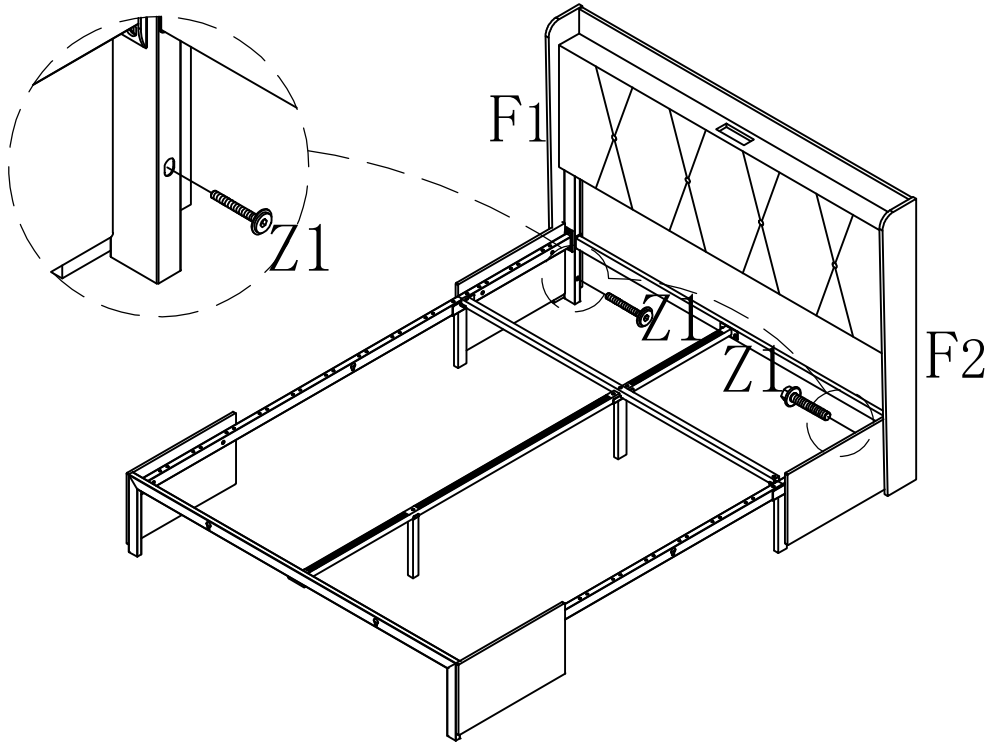

# 14



Z7\*2PCS

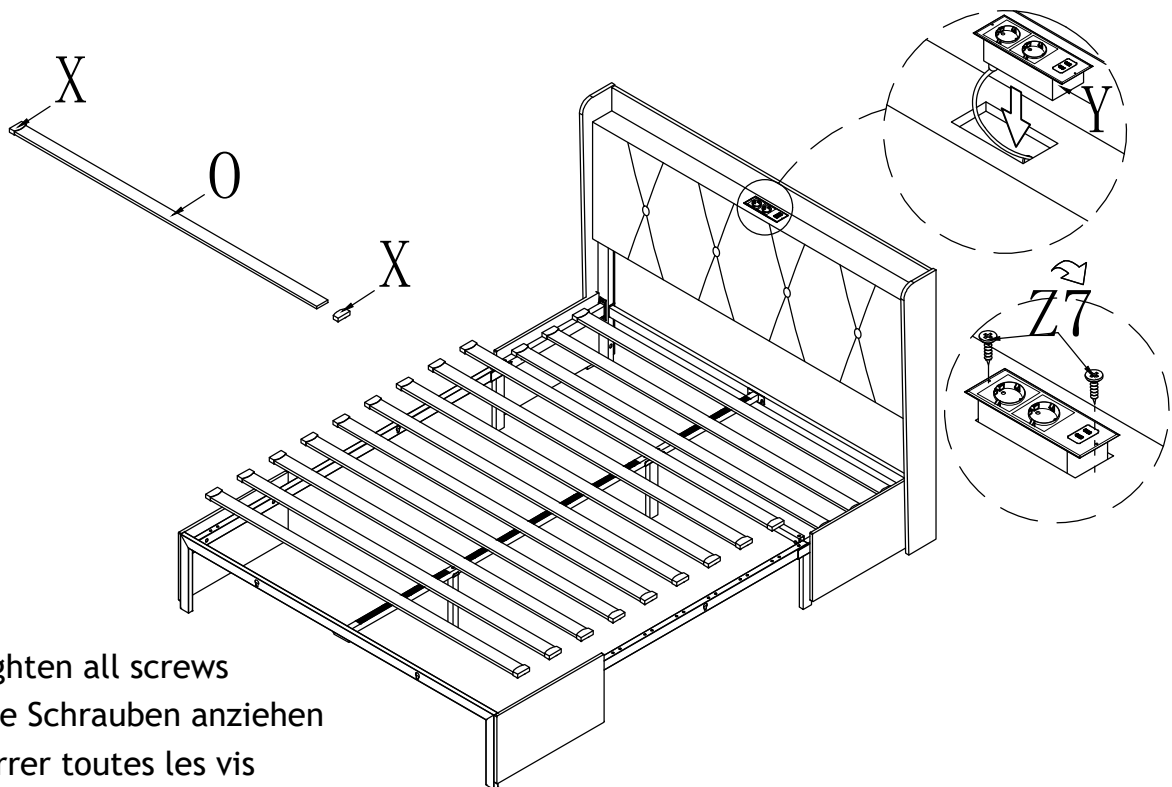

- Tighten all screws
- Alle Schrauben anziehen
- Serrer toutes les vis

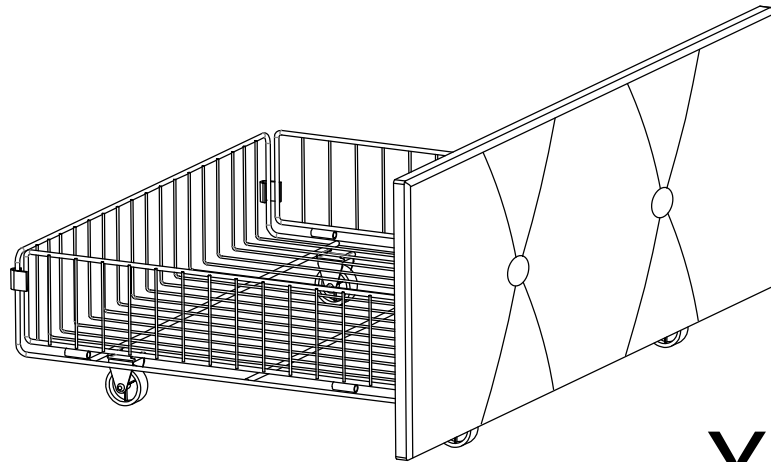

x 2

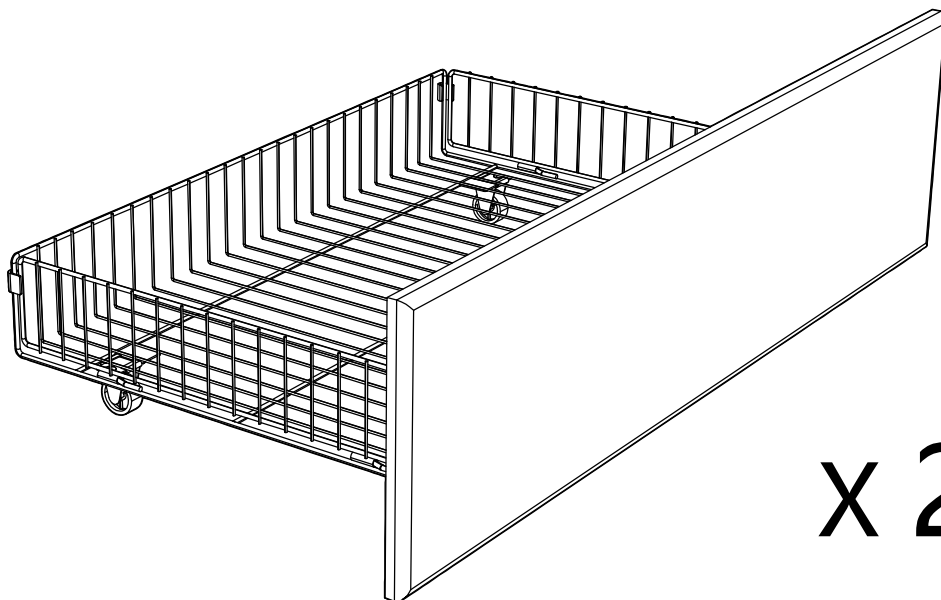

x 2

- Montageschritte für Schubladen
- Drawer Installation Steps
- Etapas de l'installation du tiroir

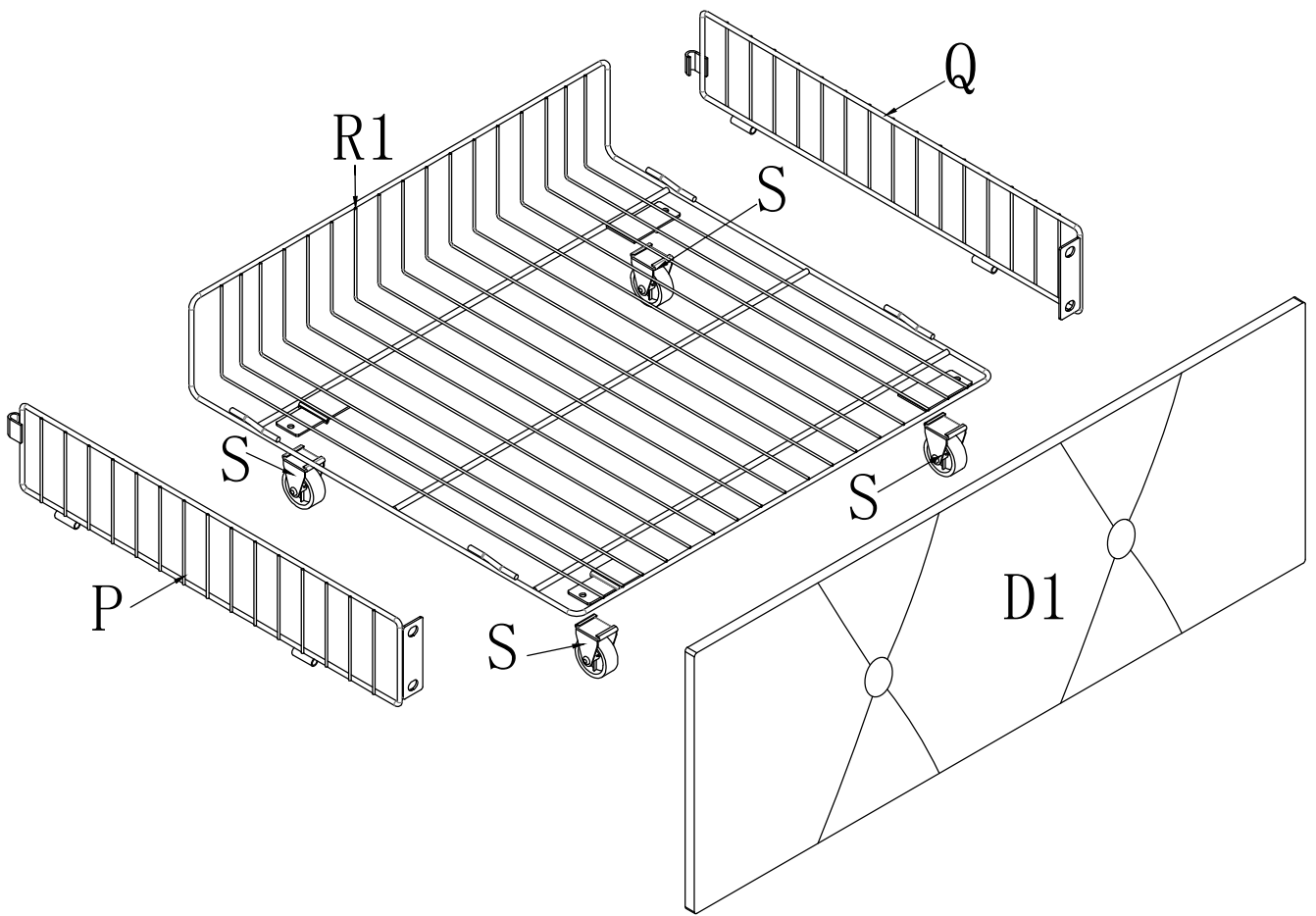

15



S\*8PCS

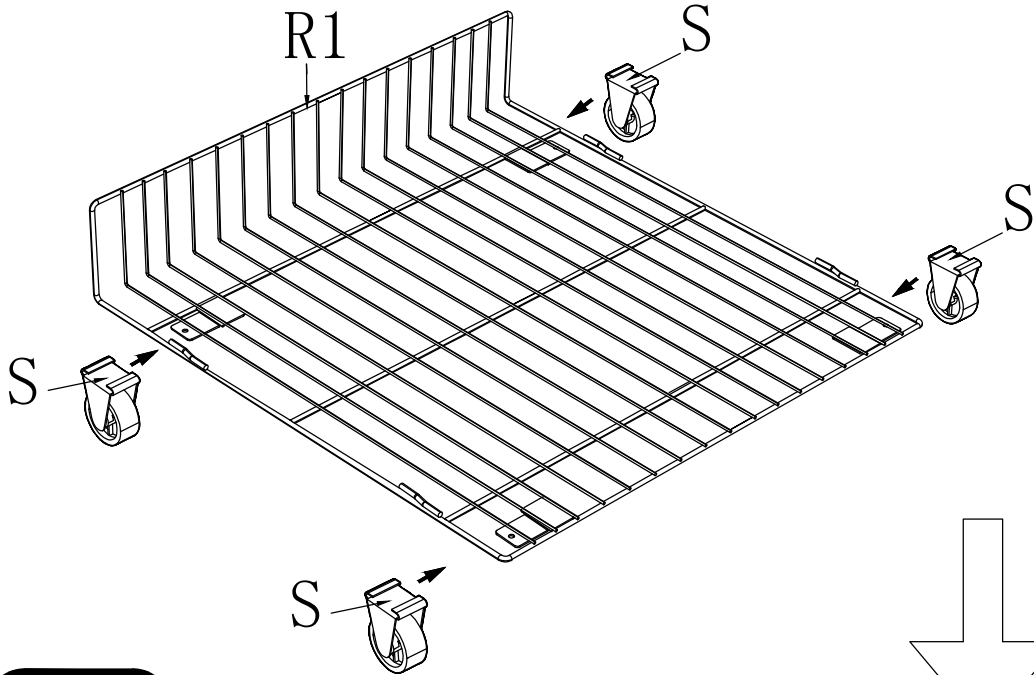

X2

16

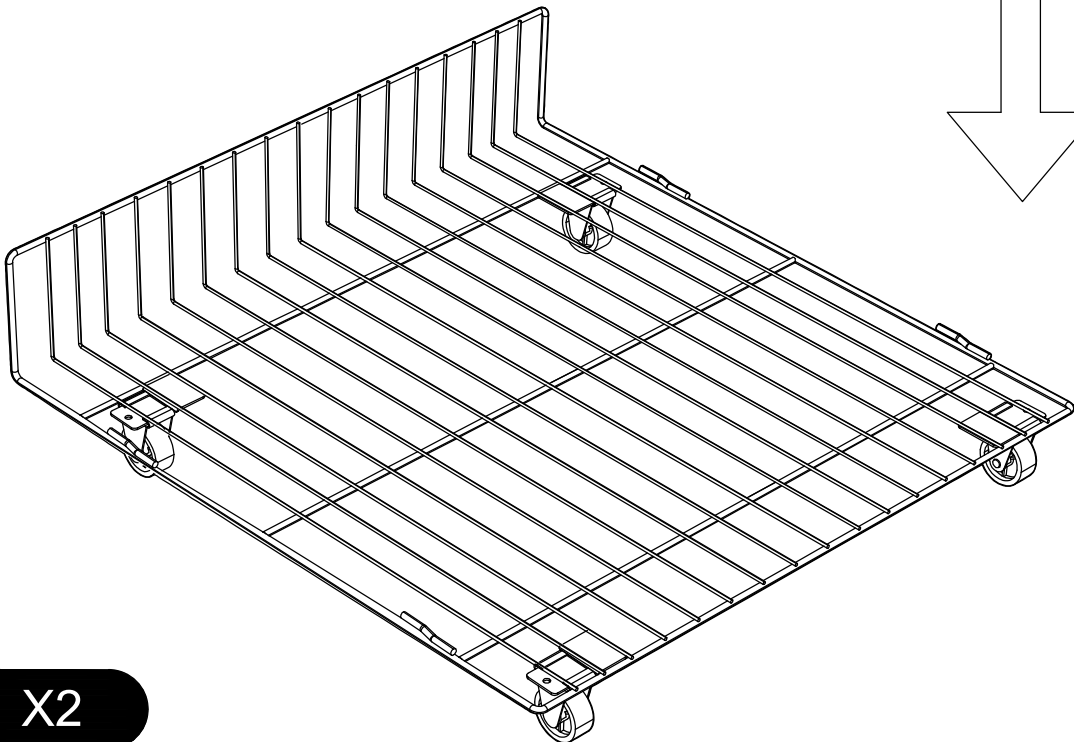

X2



17



Z8\*8PCS

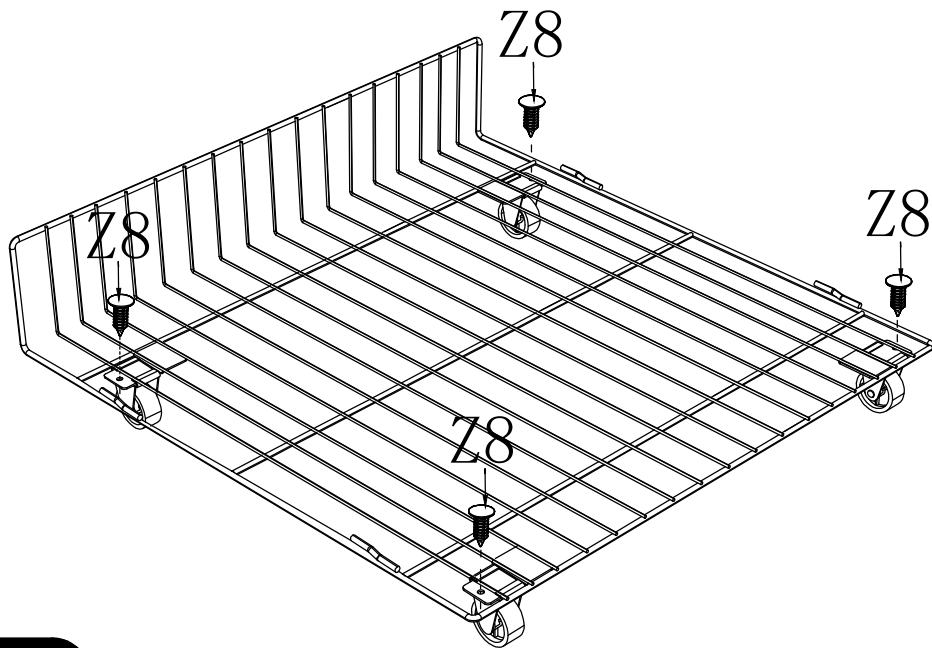

X2

18

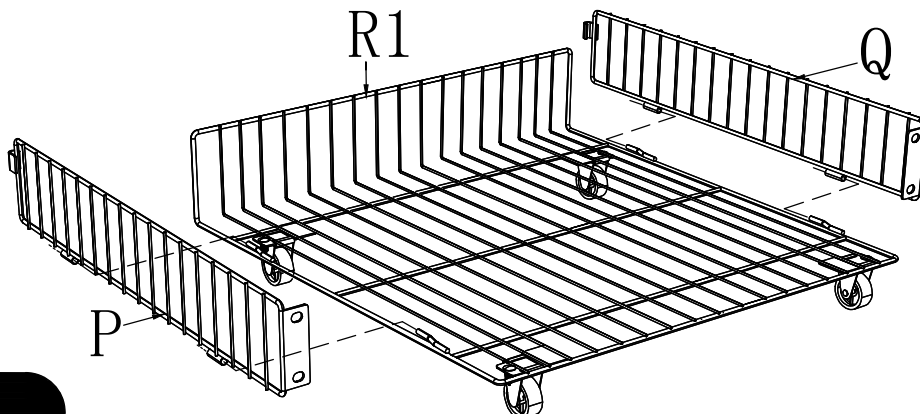
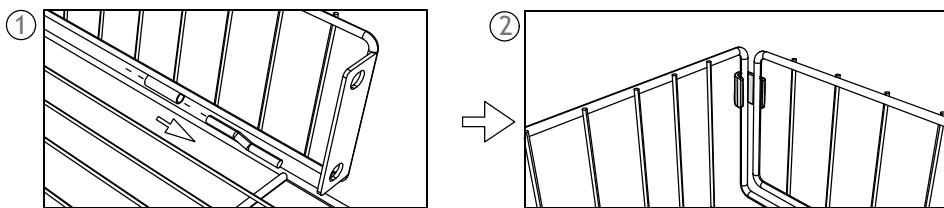

X2

19

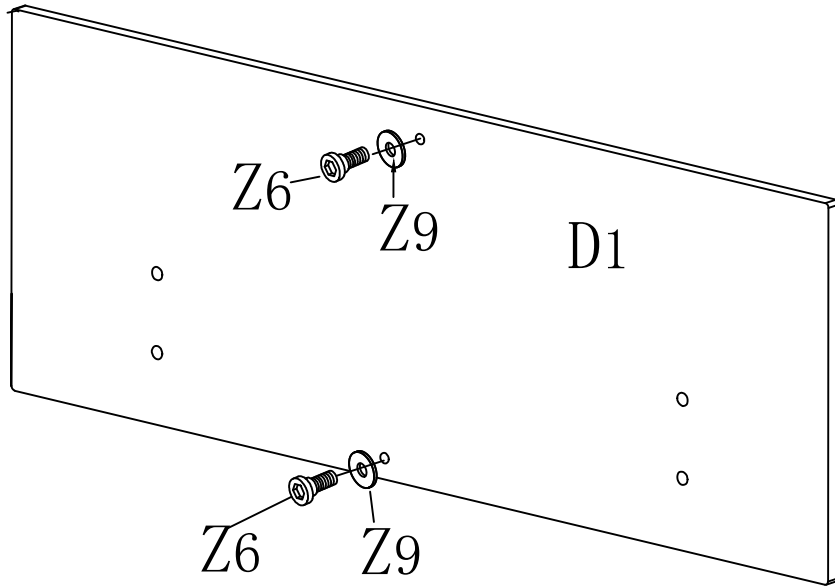
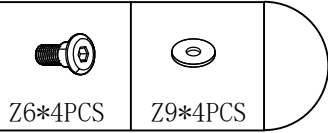

X2

20

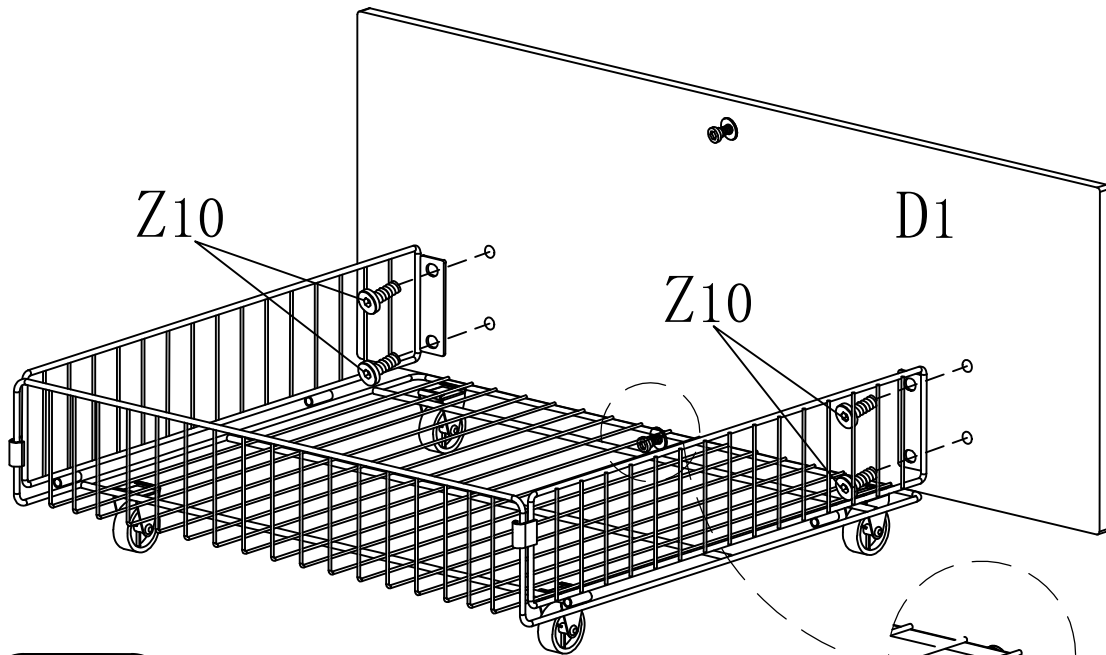
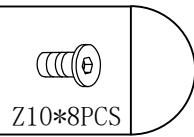

X2

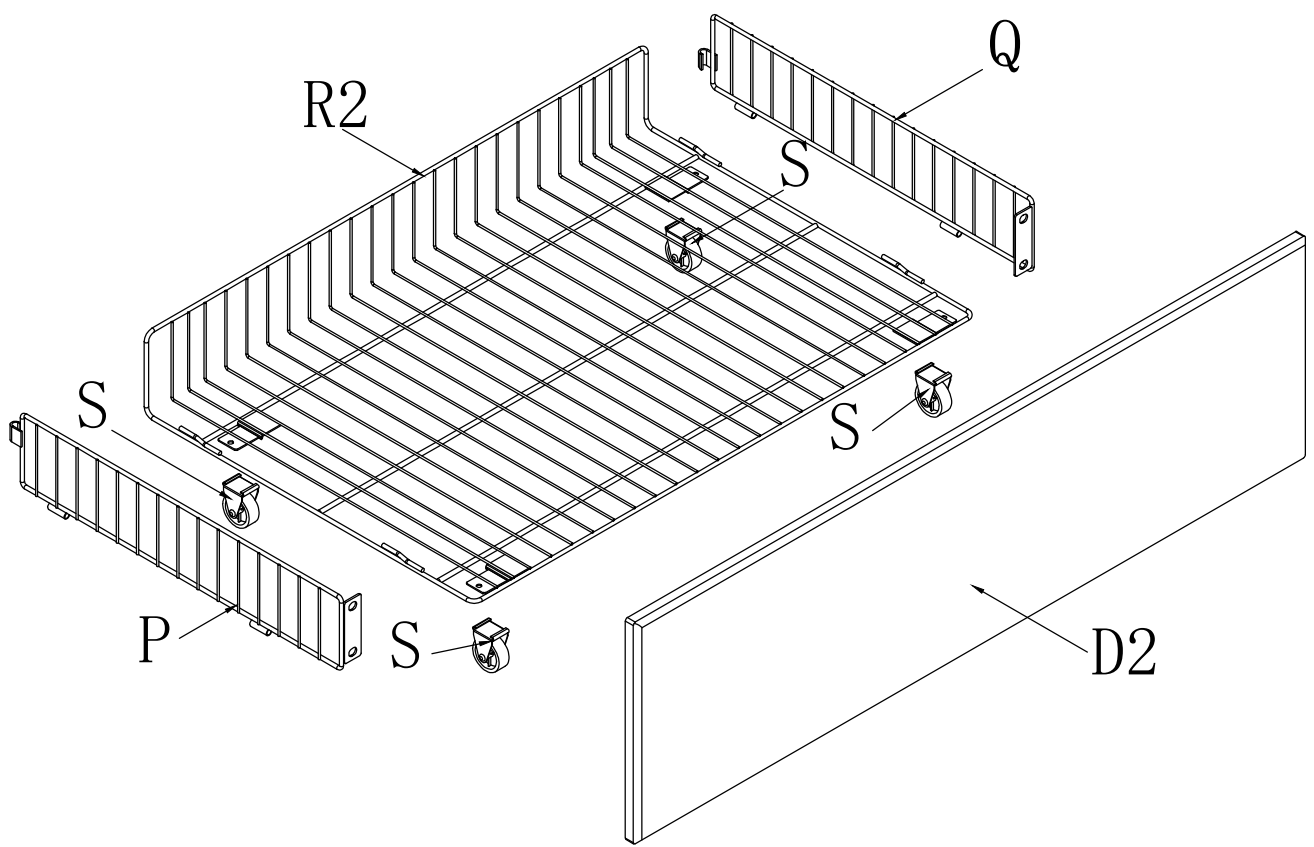

21



S\*8PCS

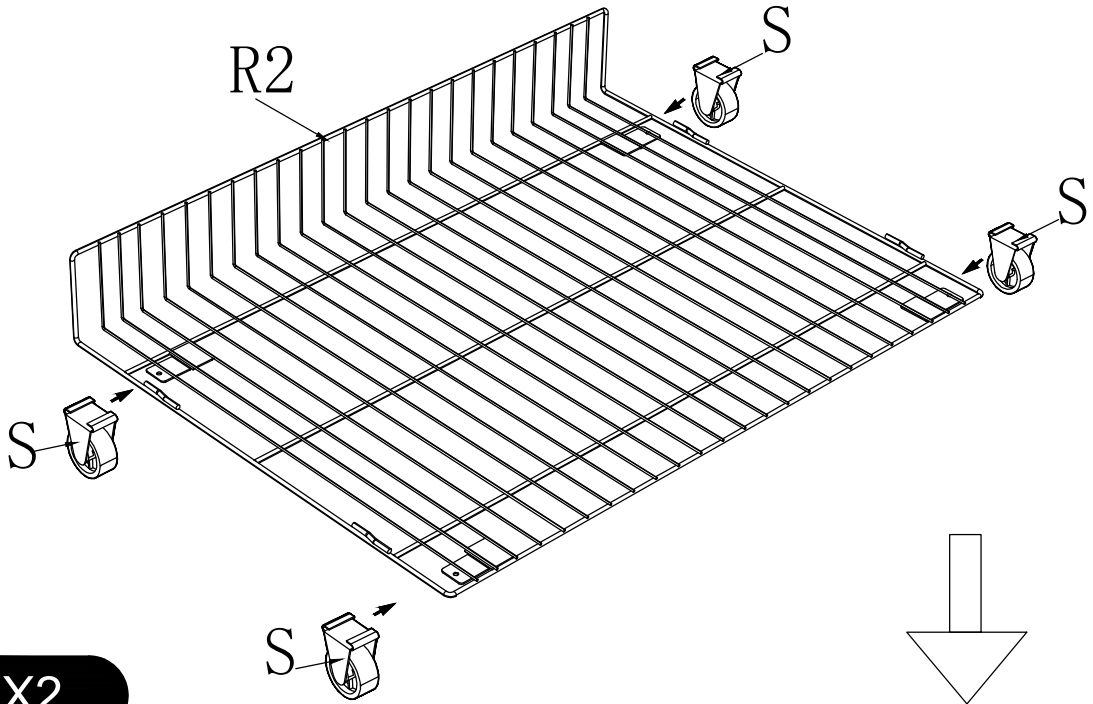

X2

22

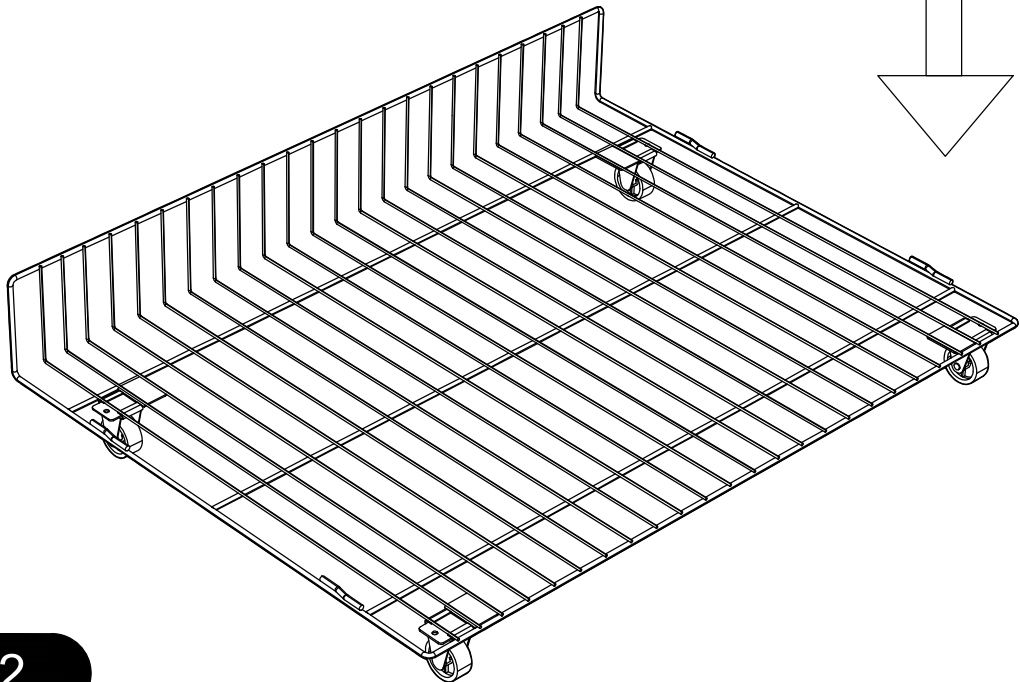

X2

23



Z8\*8PCS

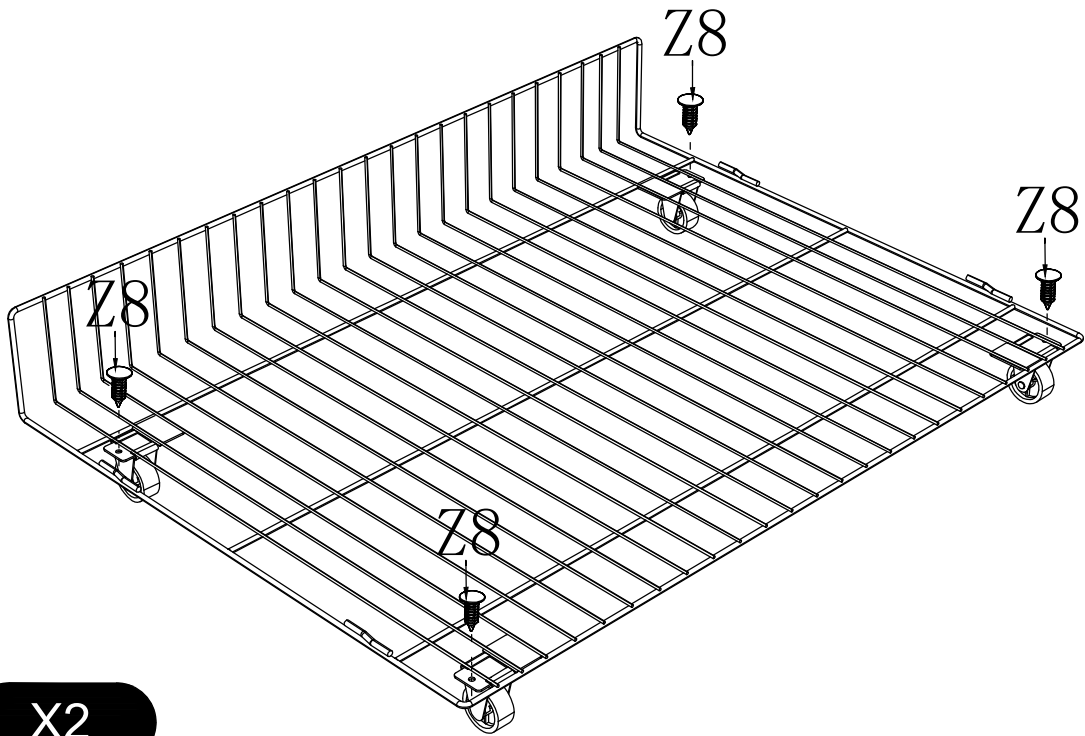

X2

24

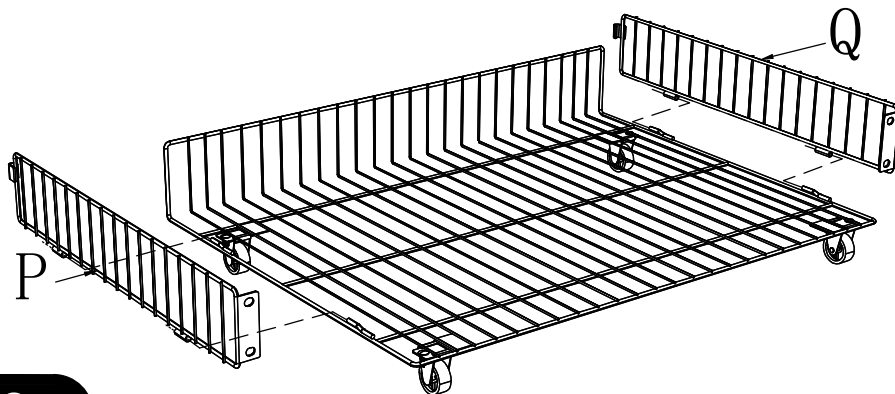
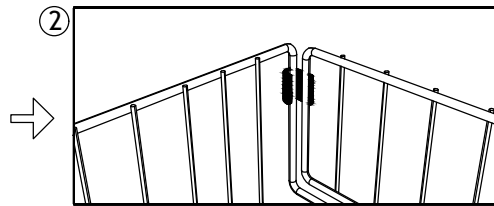
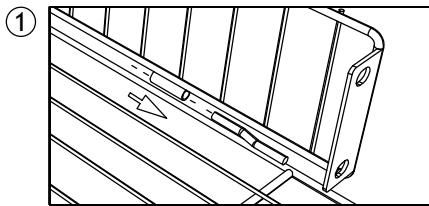

X2

25

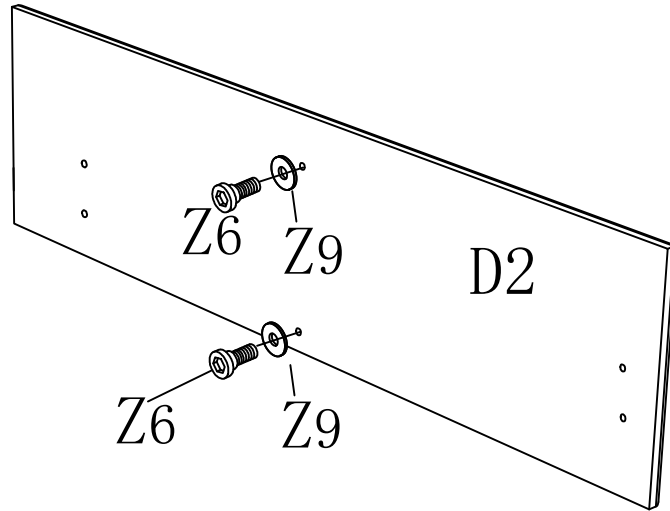
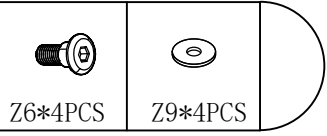

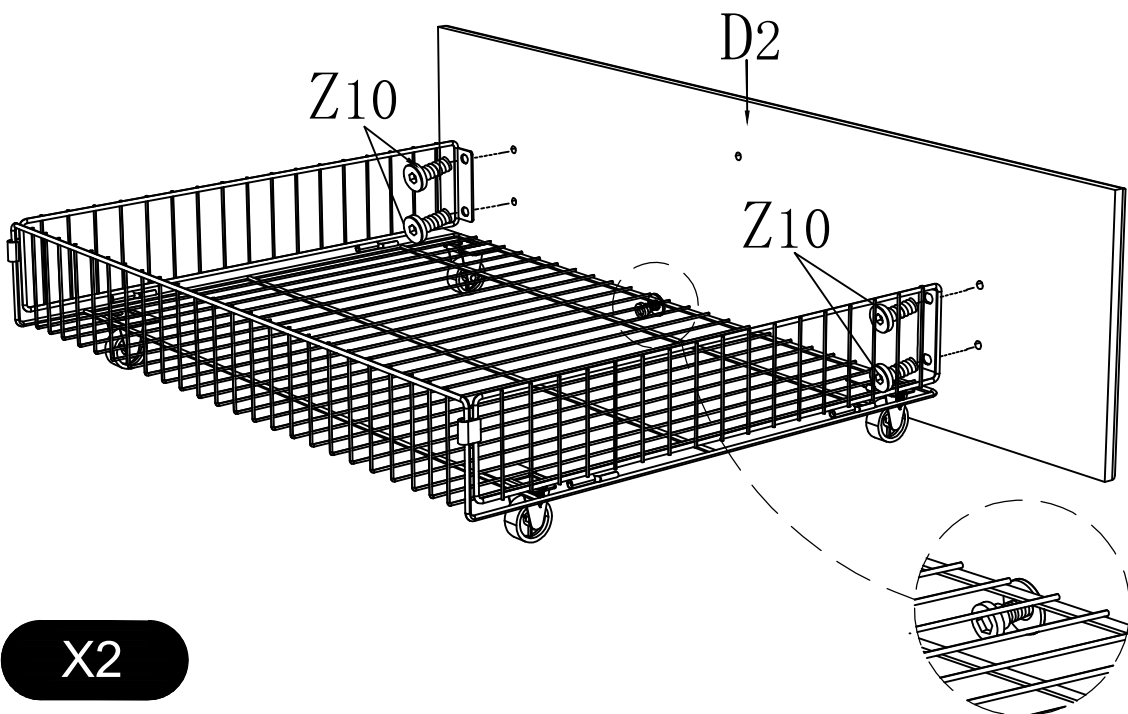
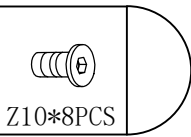

X2

26

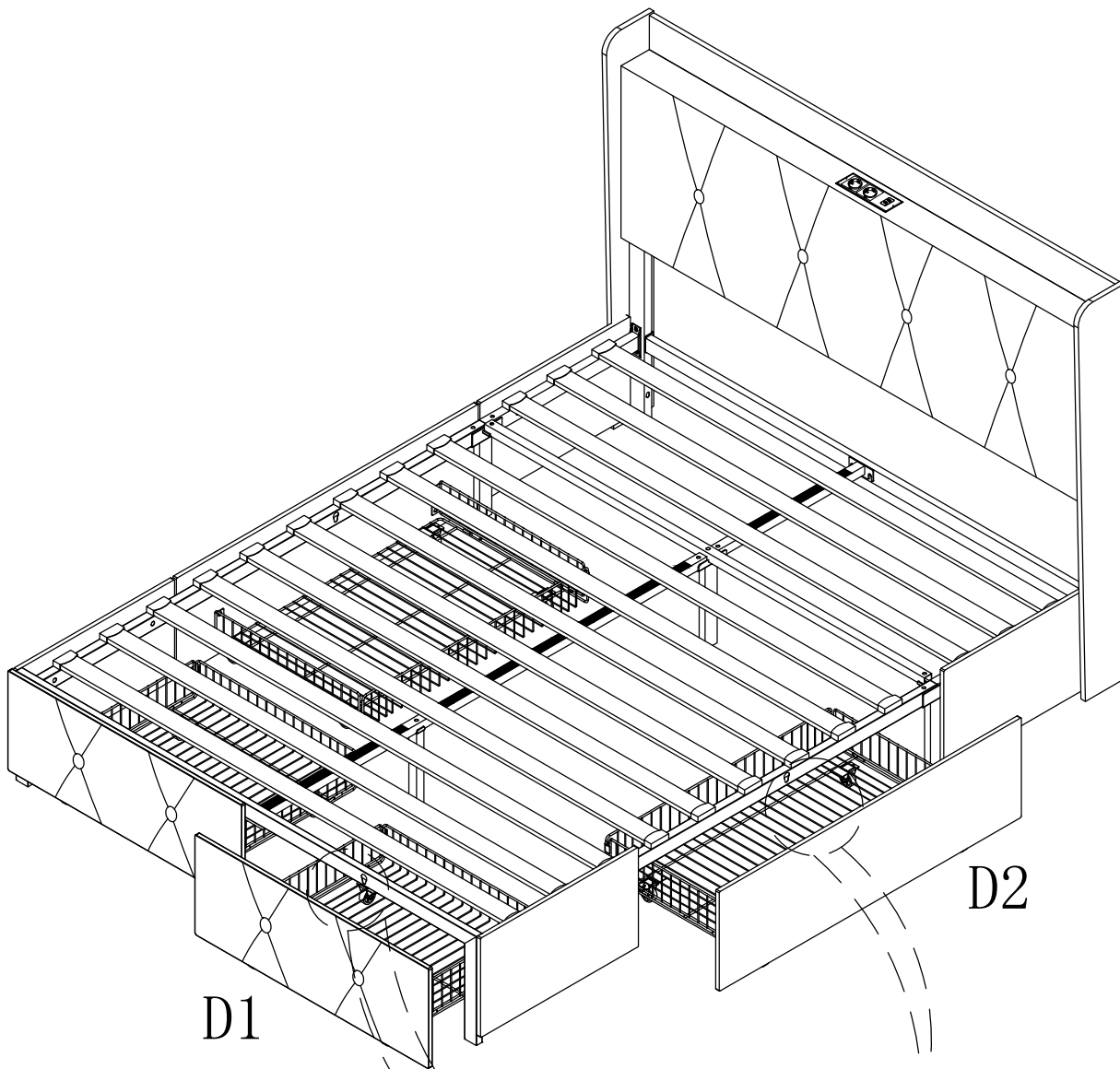

X2



Lift the panel to allow the "Z6" to match the hole  to secure the drawers. Same way for pulling out.

Heben Sie die Platte an, um das "Z6" mit dem Loch  abzugleichen, um die Schubladen zu sichern. Genauso zum Herausziehen.

Soulevez le panneau pour permettre au "Z6" de s'aligner avec le trou  pour sécuriser les tiroirs. Même procédé pour les retirer.

