

(D) Montageanleitung

(GB) Assembly instructions

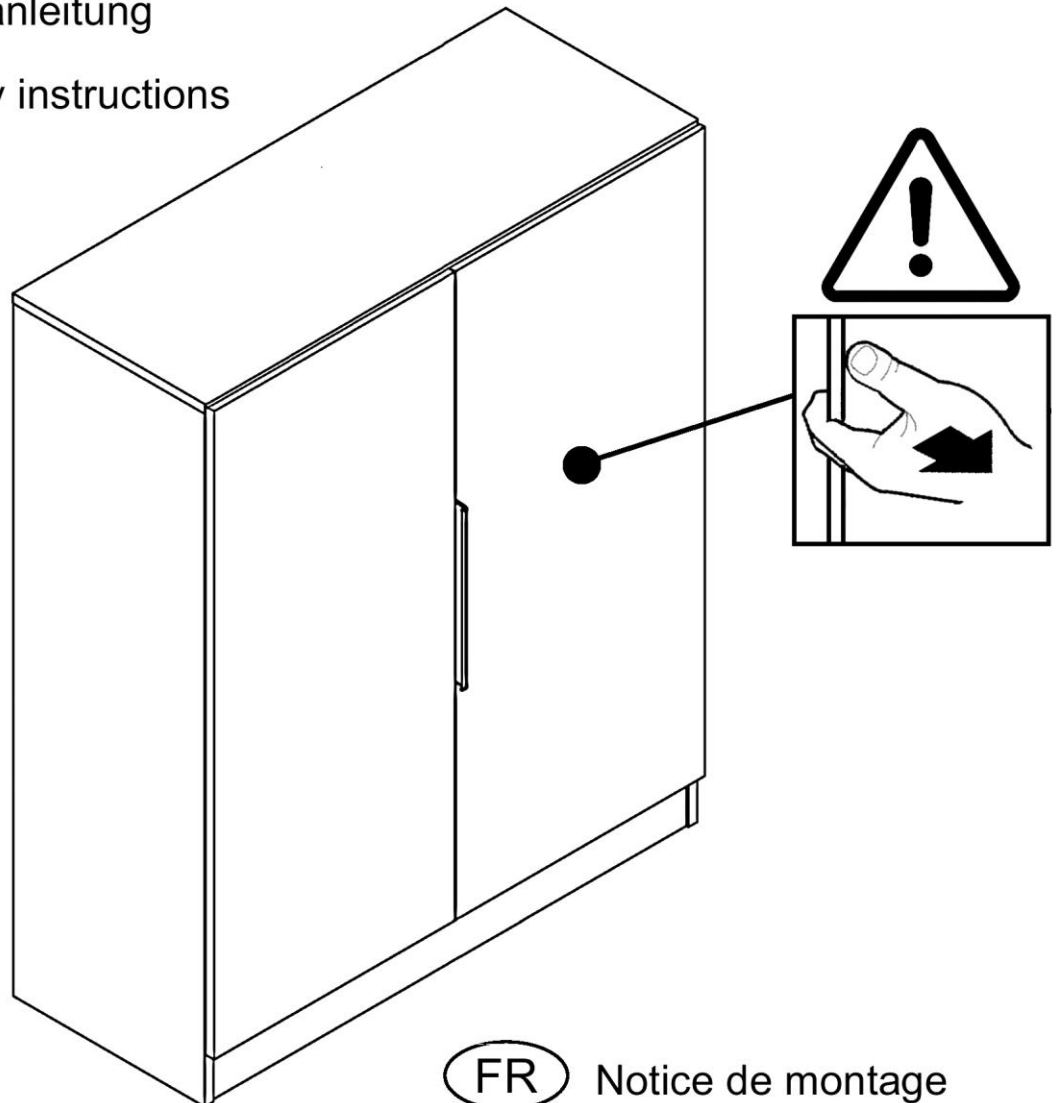

(FR) Notice de montage

(RU) Инструкция по монтажу

(TR) Montaj talimati

(IT) Istruzioni di montaggio

(SK) Návod na montáž

(CZ) Montážní návod

(HU) Szerelési útmutató

(NL) Handleiding voor de montage

(PL) Instrukcja montażu

(RO) Instrucțiuni de montaj

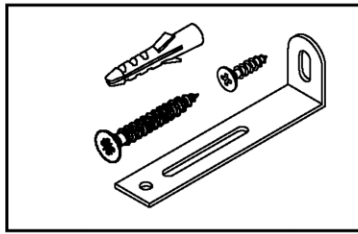

1.

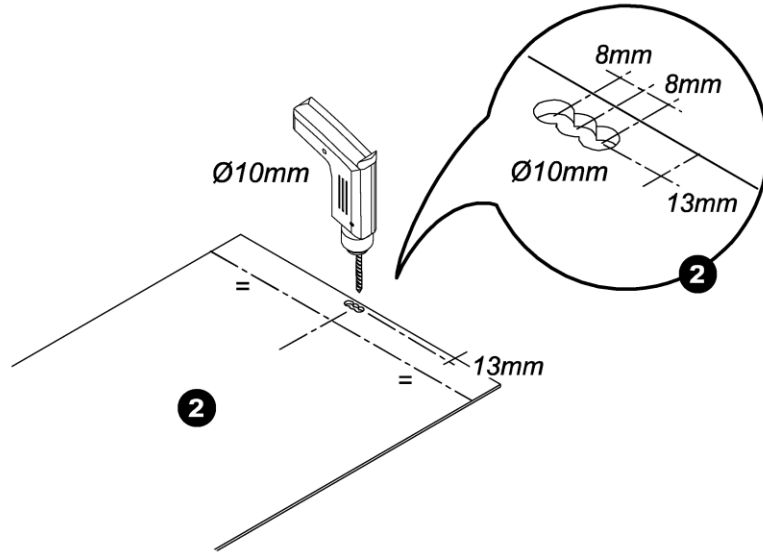

2.

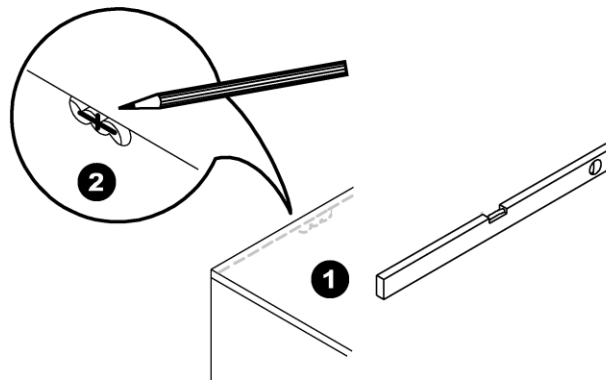

3.

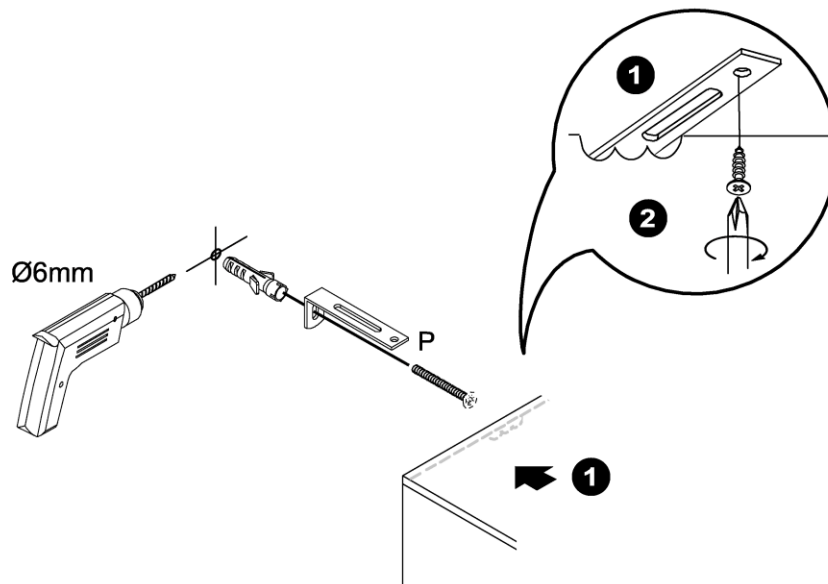

Service • Asststenza • Dienstverlening • Serwis  
 Servis • Szerviz • Сервисная служба

Name • Nom • Nome • Naam •  
 Nazwa • Jméno • Názov • Név •  
 Denumire • Isim • Название

Nr. • No. • N° • Номер • Č • Sz

Тур • Туре • Tip • Típus • Тиро •  
 Тип

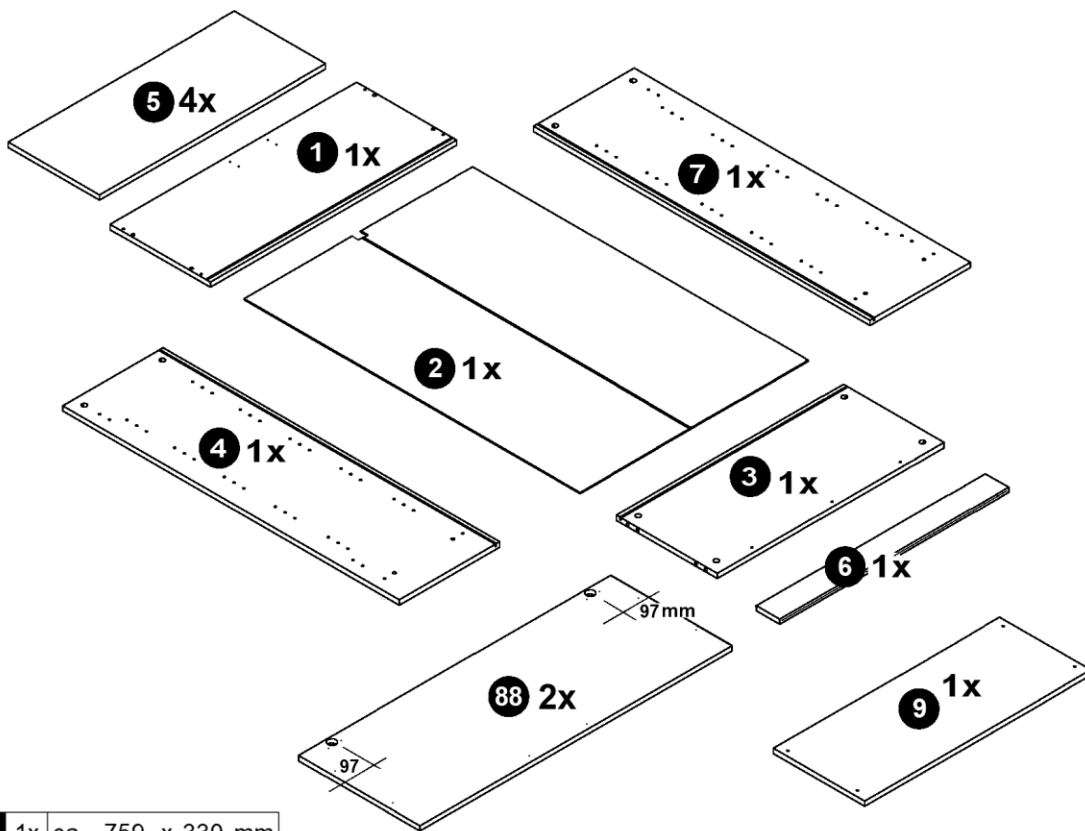
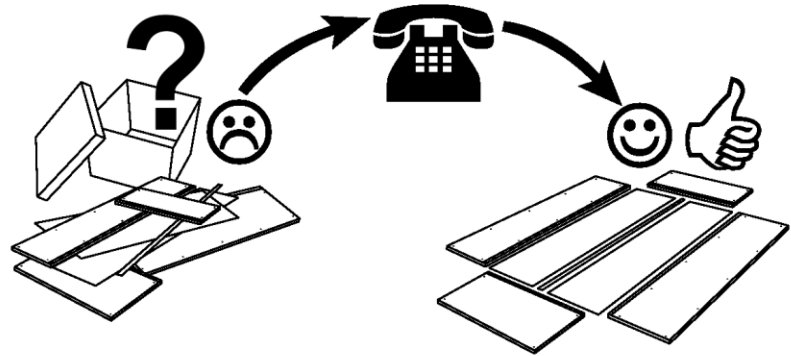
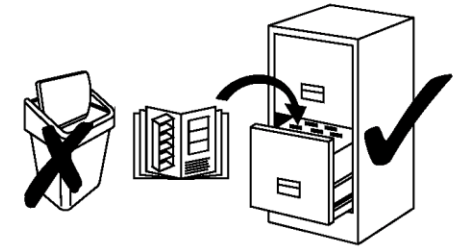

<b>1</b>	1x	ca. 759 x 330 mm	<b>4</b>	1x	ca. 1185 x 330 mm	<b>6</b>	1x	ca. 728 x 77 mm	<b>88</b>	2x	ca. 1123 x 377 mm
<b>2</b>	1x	ca. 1105 x 740 mm	<b>5</b>	4x	ca. 728 x 300 mm	<b>7</b>	1x	ca. 1185 x 330 mm	<b>9</b>	1x	ca. 728 x 300 mm
<b>3</b>	1x	ca. 728 x 330 mm									

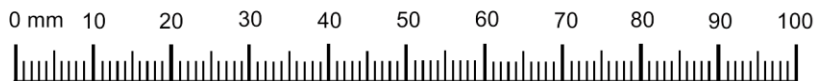
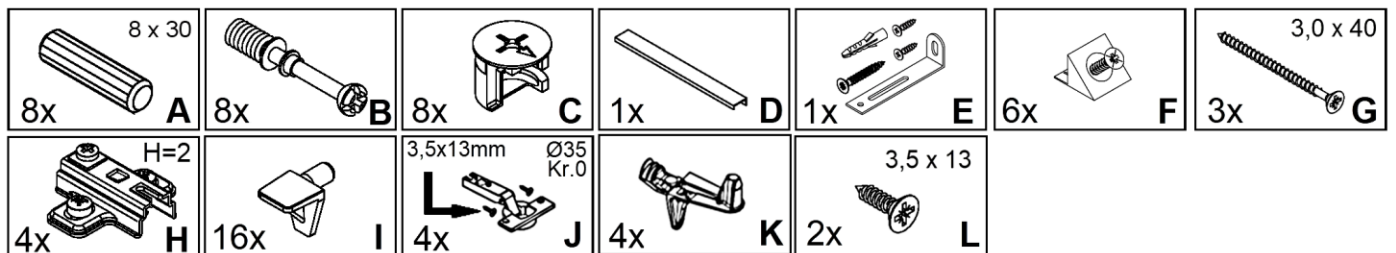

**1**

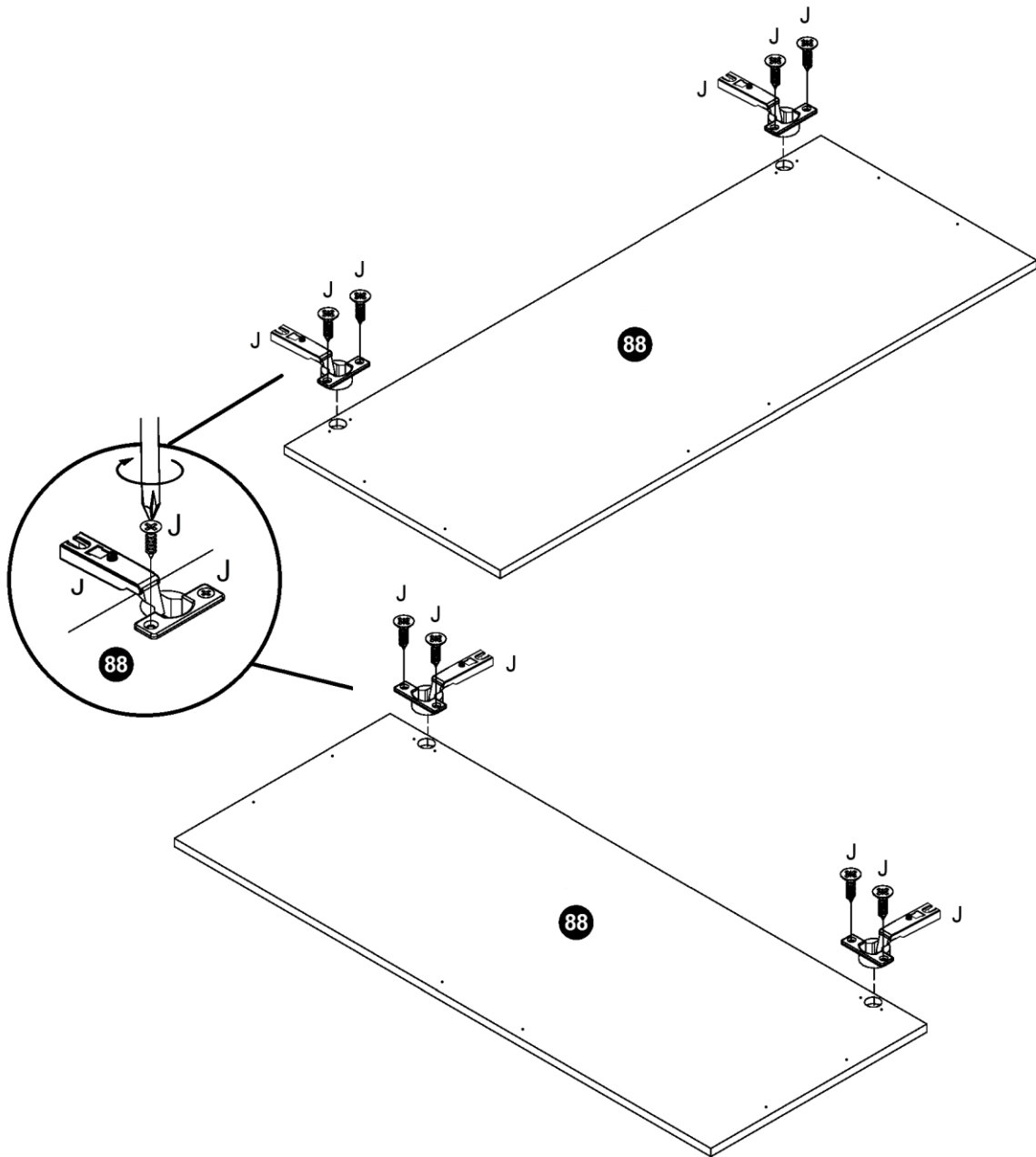
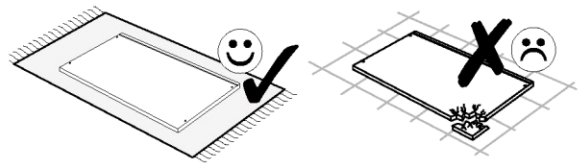
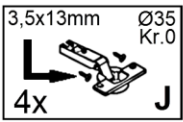

# 2

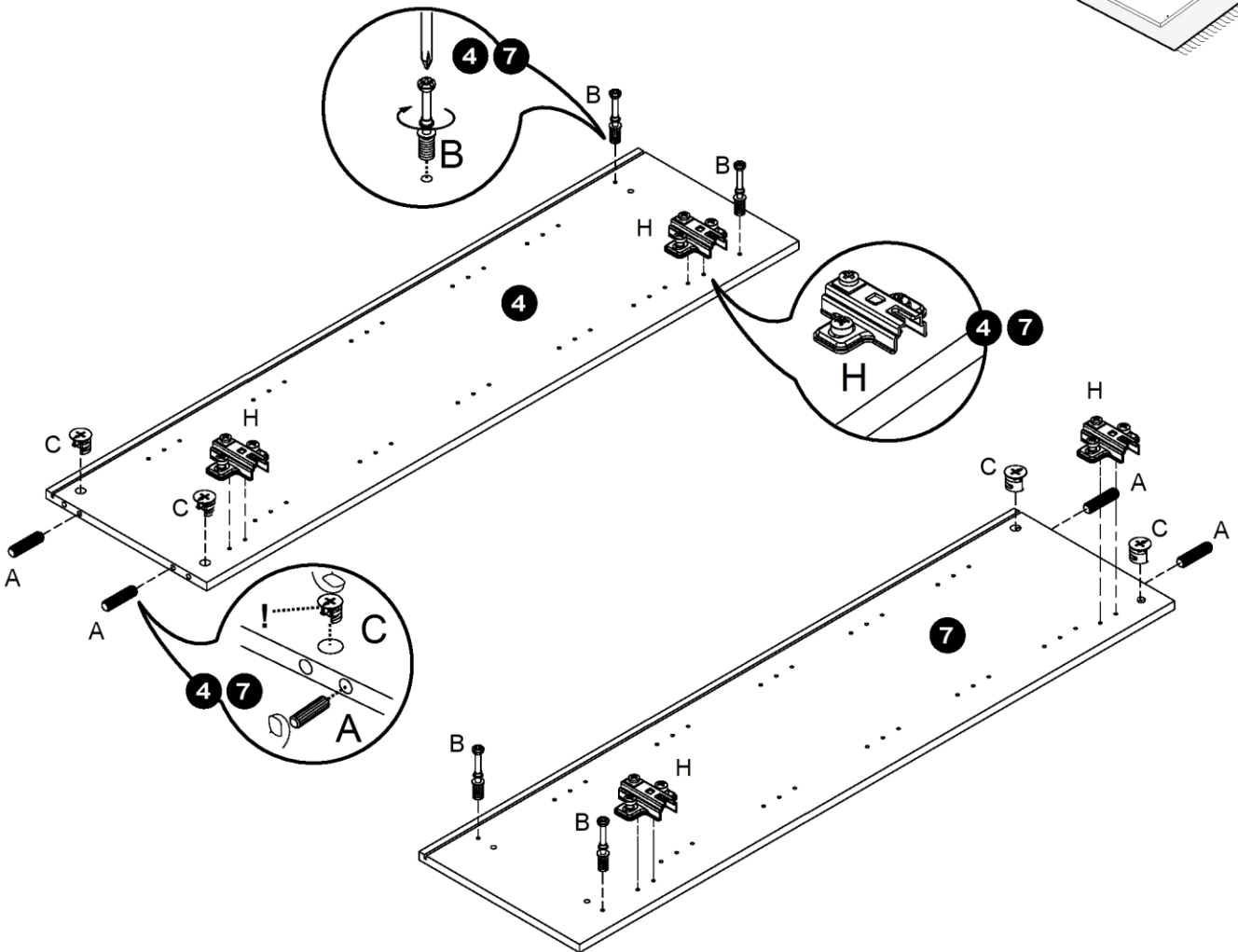
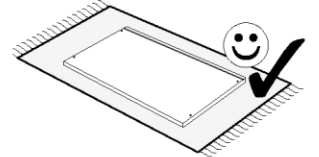
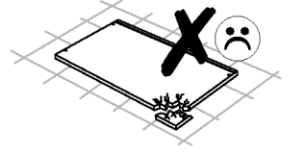
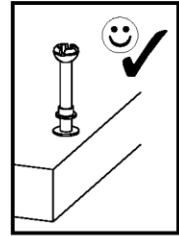
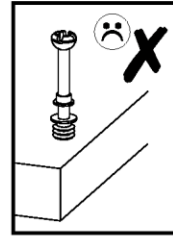
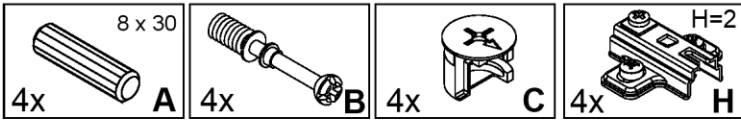

**3**

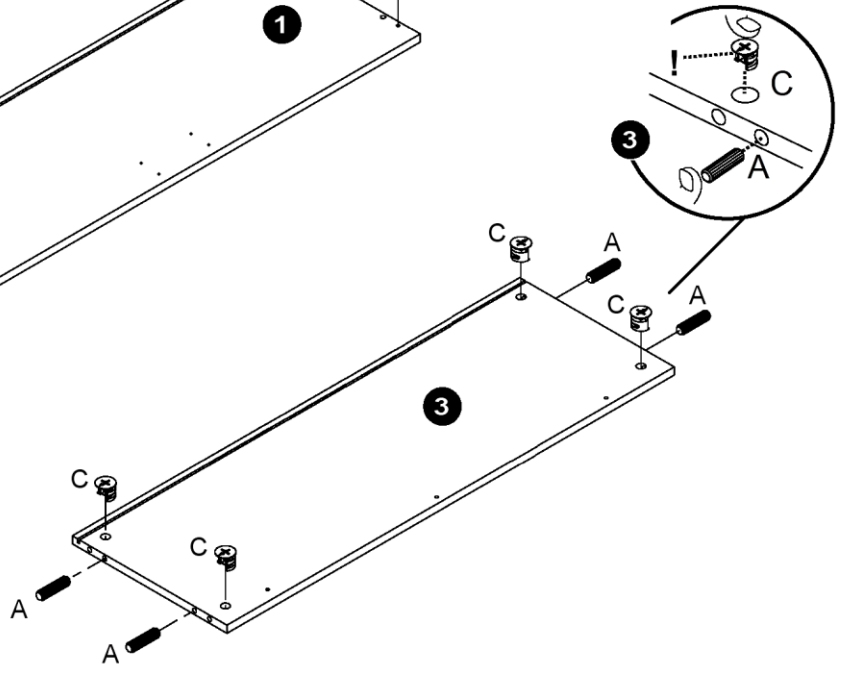
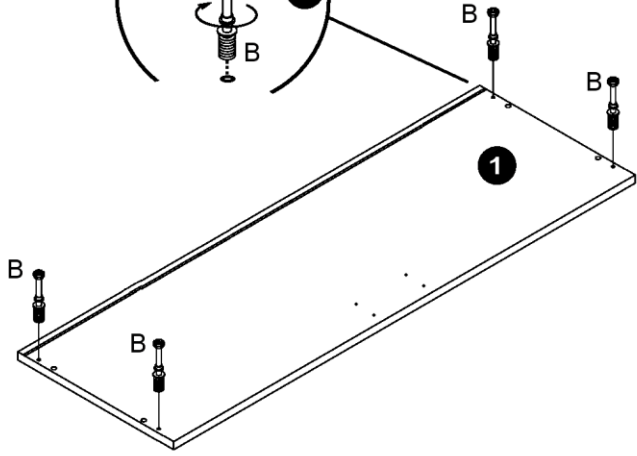
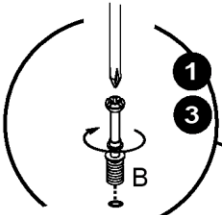
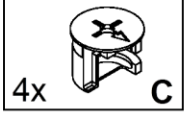
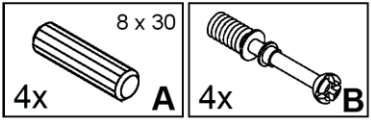
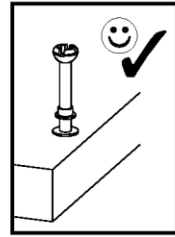
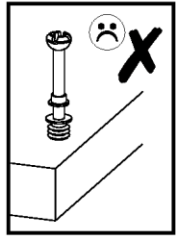
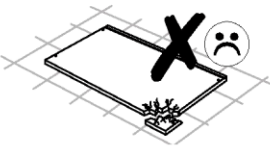
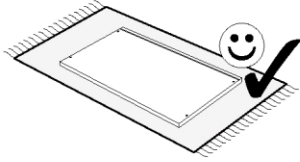

**4**

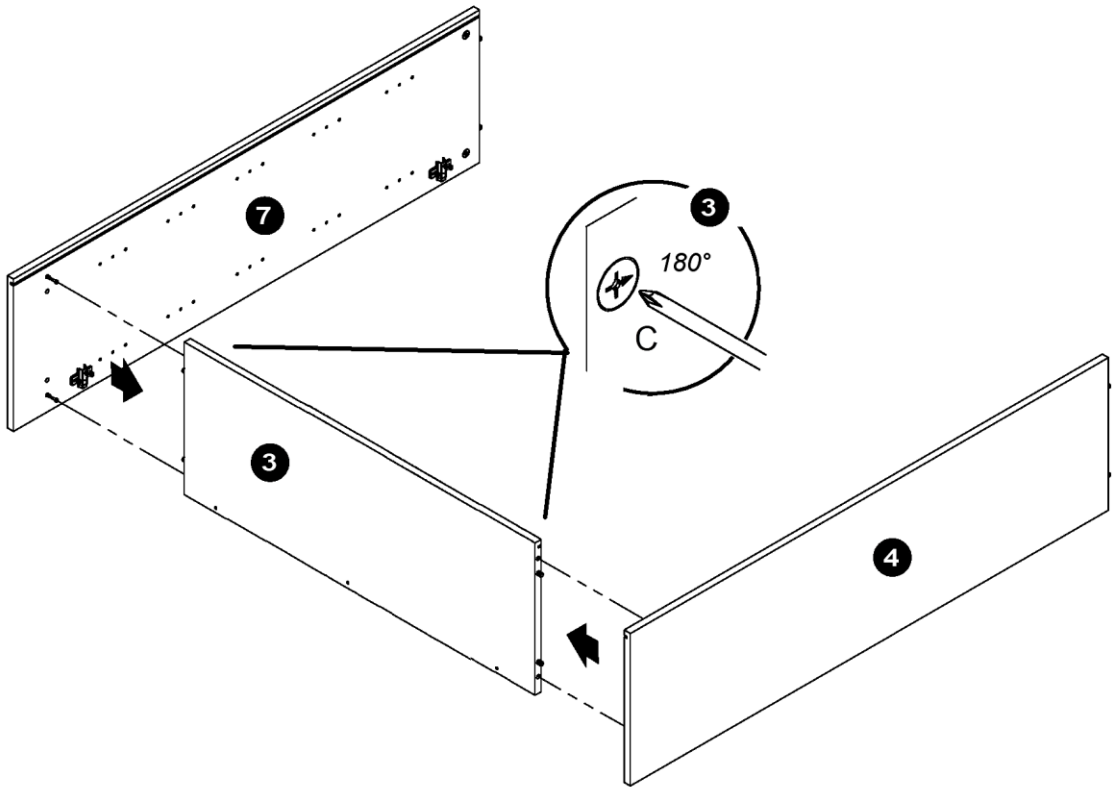

# 5

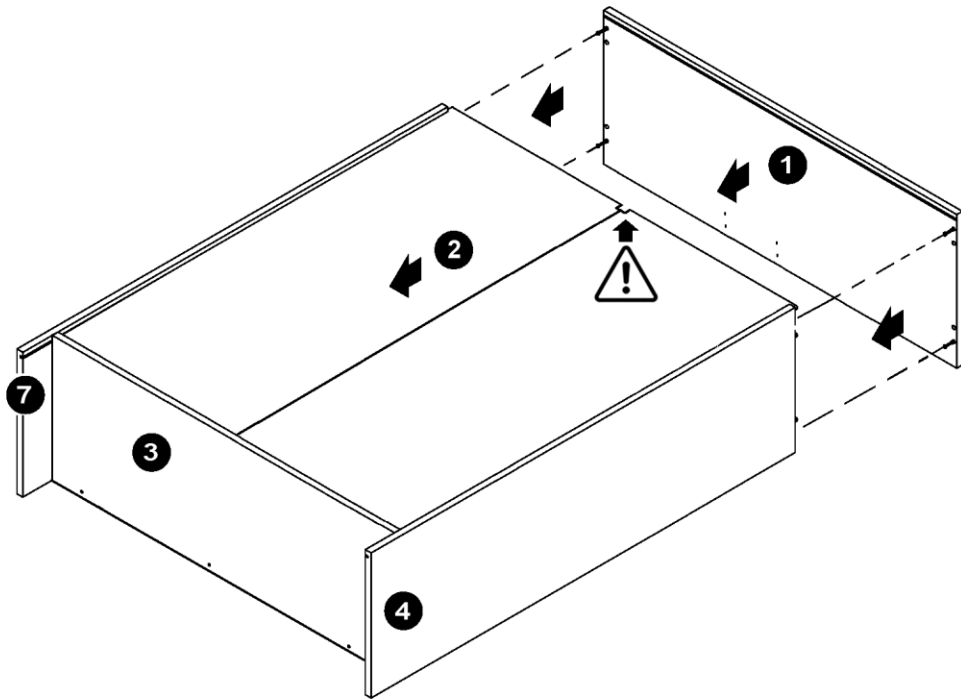
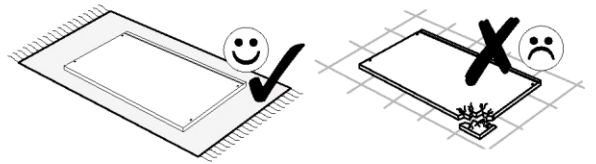

# 6

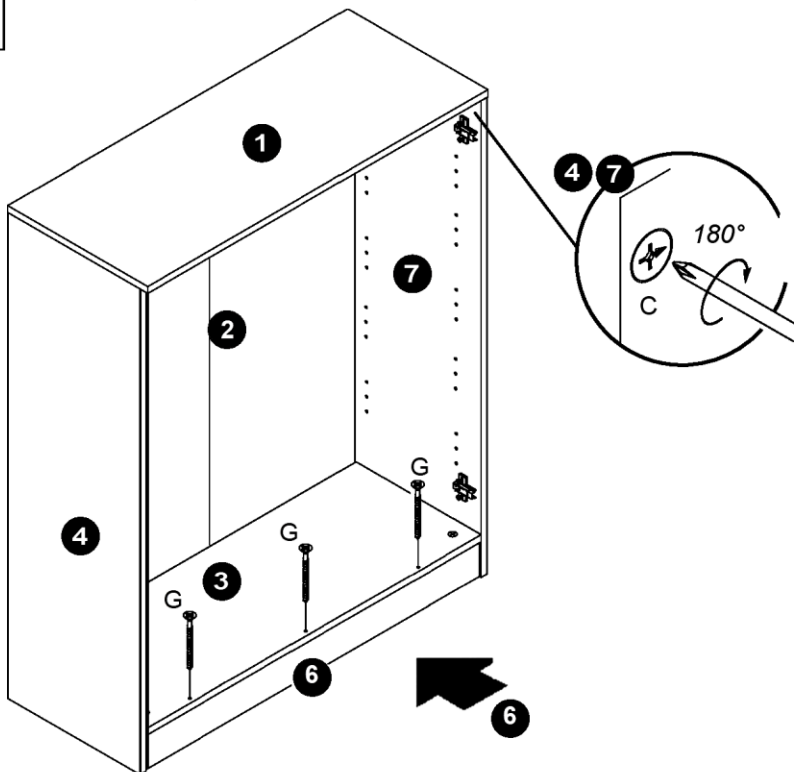
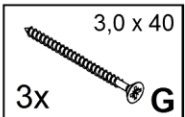



# 7

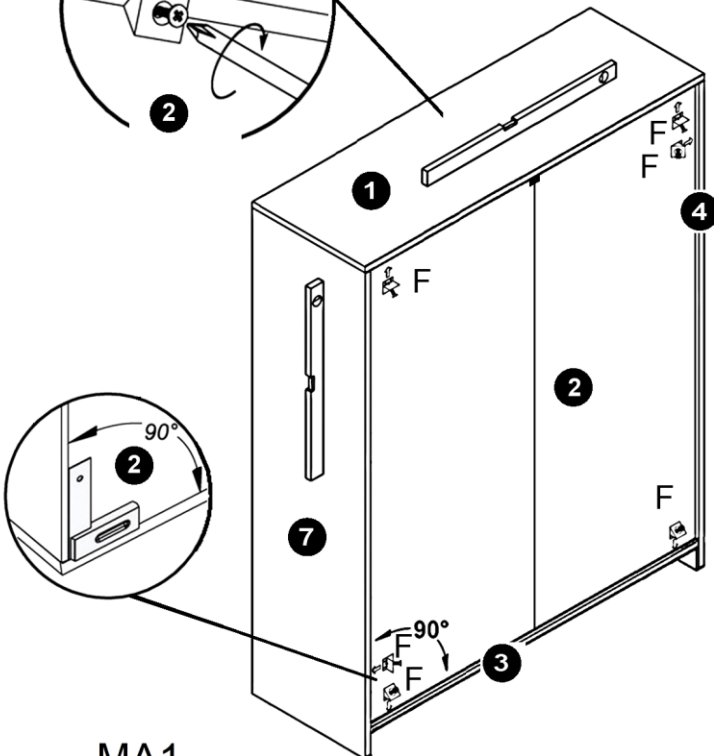
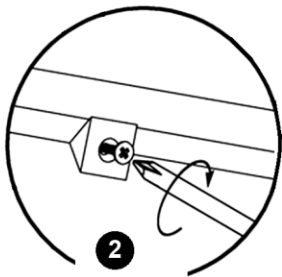
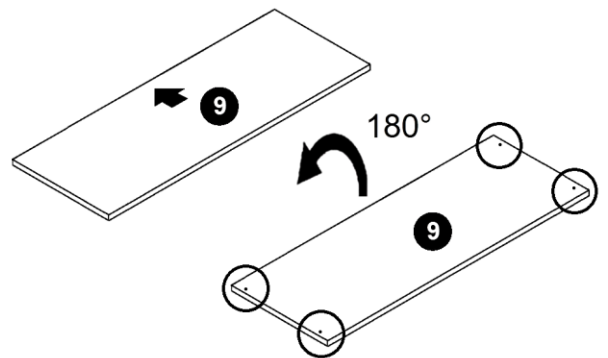
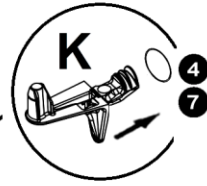
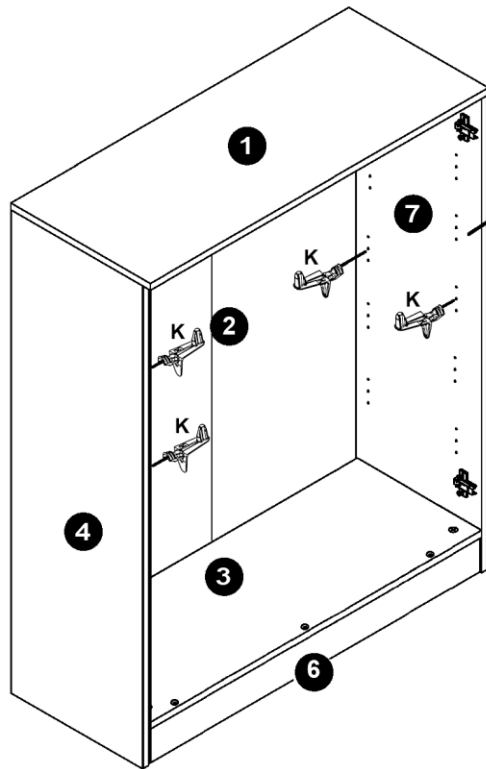
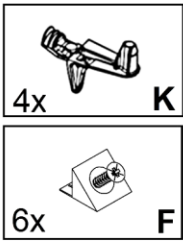

- (D) Wichtig! Bitte genau hier anbringen!  
 (GB) Important! Please attach right here!  
 (FR) Important! Veuillez joindre ici!  
 (RU) Важно! Пожалуйста, прикрепите прямо здесь!  
 (TR) Önemli! Lütfen buraya ekleyin!  
 (IT) ! importante Si prega di allegare proprio qui!  
 (NL) Belangrijk! Voeg hier toe!  
 (PL) Ważne! Dołącz tutaj!  
 (CZ) Důležité! Připojte se prosím zde!  
 (RO) Important! Vă rugăm să atașați chiar aici!  
 (HU) Fontos! Kérjük, csatolja ide!  
 (SK) Dôležité! Pripojte, prosím, tu!

MA1



8

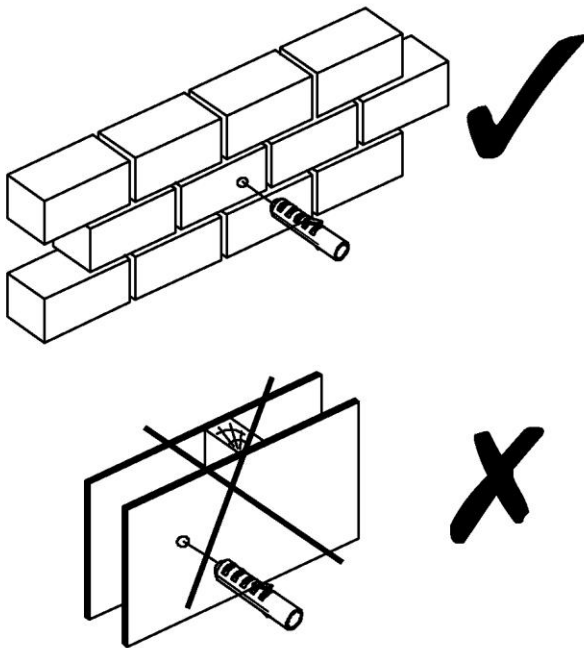
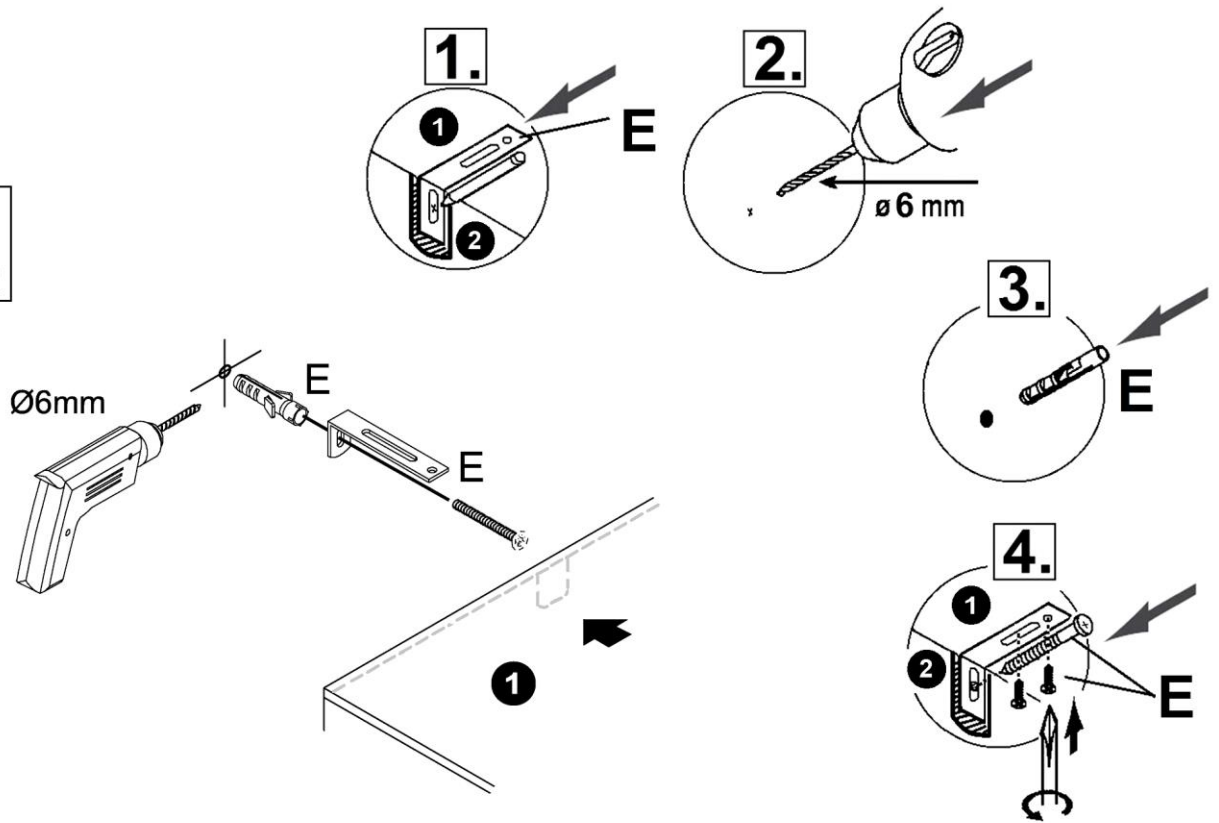
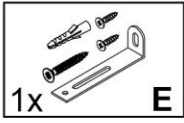

Achtung • Attention • Attenzione Opgelet • Uwaga • Pozor • Figyelem Atenție • Dikkat • Внимание	
(D)	Wandbefestigung dient als Kippschutz – unbedingt anbringen! Bei einigen Wandtypen kann ein Spezialdübel erforderlich sein!
(GB)	The wall fastening serves to prevent tipping – be absolutely sure to mount it! For certain wall types, a special wall plug may be necessary!
(FR)	La fixation murale sert de protection contre le basculement – à installer impérativement ! Pour certains types de murs il faut des chevilles spéciales !
(IT)	Il fissaggio alla parete serve da protezione anti-ribaltamento – attaccarla assolutamente! Per alcune strutture di parete può essere necessario un tassello speciale!
(NL)	Bevestiging aan de muur dient als kantelbescherming – zeker en vast bevestigen! Bij enkele muurtypes is een speciale plug misschien vereist!
(PL)	Mocowanie do ściany jest jednocześnie zabezpieczeniem przed przewróceniem – koniecznie zamontować! Do niektórych rodzajów ścian koniecznie zastosować specjalne kołki mocujące.
(CZ)	Montáž na stěnu slouží jako ochrana proti převrnutí – bezpodmienečně umístěte! U některých typů stěn může být zapotřebí speciální hmoždinka!
(SK)	Upevnenie na stenu slúži ako ochrana proti prevráteniu – bezpodmienečne použite! Pre niektoré druhy stien môže byť potrebná špeciálna hmoždinka!
(HU)	A termékét a falhoz kel rögzíténi, különben az felborulhat! Egyes faltípusoknál speciális tiplít kell használni!
(RO)	Sistemul de fixare la perete servește ca protecție la răsturnare – de montat obligatoriu! Pentru unele tipuri de pereți este posibil să fie necesar un diblu special!
(TR)	Duvardaki sabitleme, devrilmeye karşı bir emniyet tedbiridir ve mutlaka monte edilmelidir! Bazı duvar tiplerinde bunun için özel dübel gerekli olabilir!
(RU)	Обязательно установите крепление на стене во избежание опрокидывания! Для некоторых типов стен может потребоваться специальный дюбель!

# 9

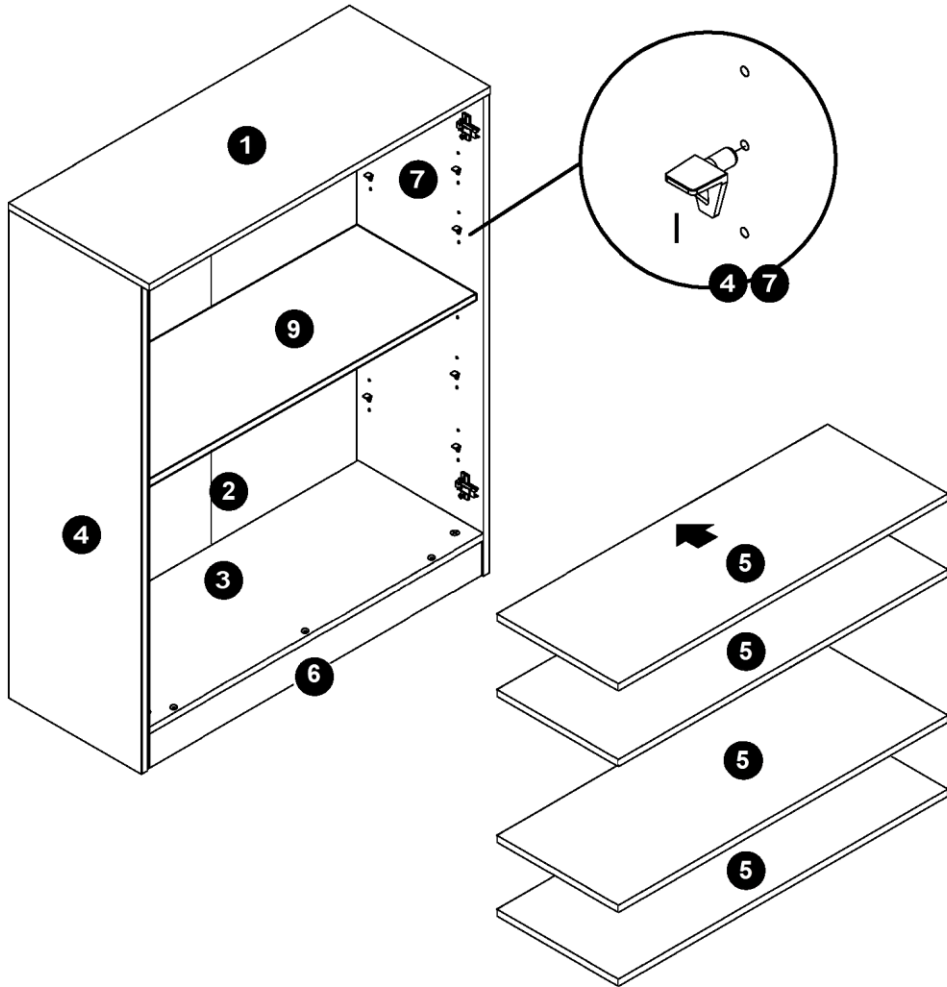
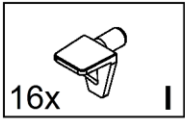

10

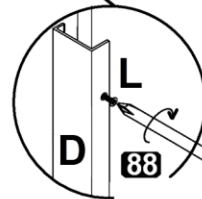
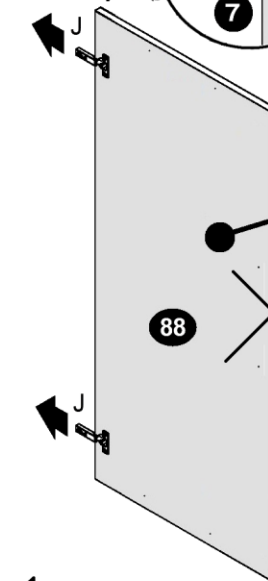
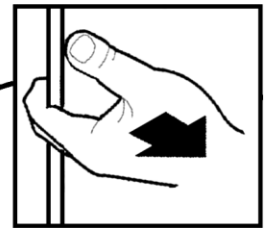
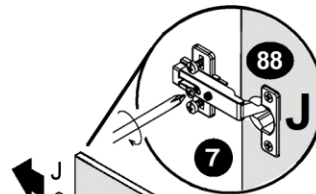
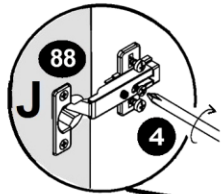
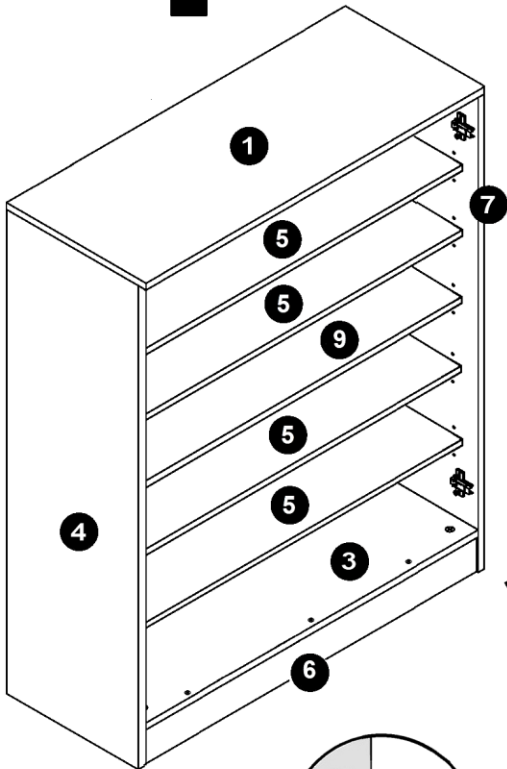
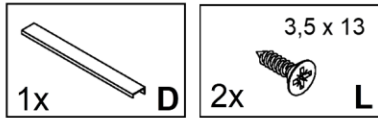

➔ 12 / 12

(D) Türen einstellen  
(Scharniere justieren)  
 (GB) Adjusting the doors  
(adjusting the hinges)  
 (FR) Régler les portes  
(ajuster les charnières)  
 (IT) Sistemare le porte  
(regolare le cerniere)  
 (NL) Deuren instellen  
(scharnieren afstellen)  
 (PL) Nastawić drzwi  
(wyregulować zawiasy)  
 (CZ) Vyrovnajte dvířka  
(seřid'te závěsy)  
 (RO) Nastavenie dverí  
(nastavenie závesov)  
 (HU) Állítsa be az ajtókat  
(állítsa be a zsanérokot)  
 (SK) Reglare uši  
(ajustare balamale)  
 (TR) Kapıların ayarlanması  
(menteşelerin seviye ayarı)  
 (RU) Регулировка дверей  
(регулировка шарнира)

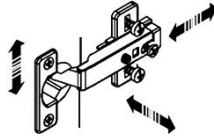

- |   |  |
|---|--|
| (D) <b>Türen einstellen</b><br>(Scharniere justieren)     | (CZ) <b>Vyrovnejte dvířka</b><br>(seřid'ťe závěsy)               |
| (GB) <b>Adjusting the doors</b><br>(adjusting the hinges) | (RO) <b>Nastavenie dverí</b><br>(nastavenie závesov)             |
| (FR) <b>Régler les portes</b><br>(ajuster les charnières) | (HU) <b>Állítsa be az ajtókat</b><br>(állítsa be a zsanérokát)   |
| (IT) <b>Sistemare le porte</b><br>(regolare le cerniere)  | (SK) <b>Reglare uši</b><br>(ajustare balamale)                   |
| (NL) <b>Deuren instellen</b><br>(scharnieren afstellen)   | (TR) <b>Kapıların ayarlanması</b><br>(menteşelerin seviye ayarı) |
| (PL) <b>Nastawić drzwi</b><br>(wyregulować zawiasy)       | (RU) <b>Регулировка дверей</b><br>(регулировка шарнира)          |

