

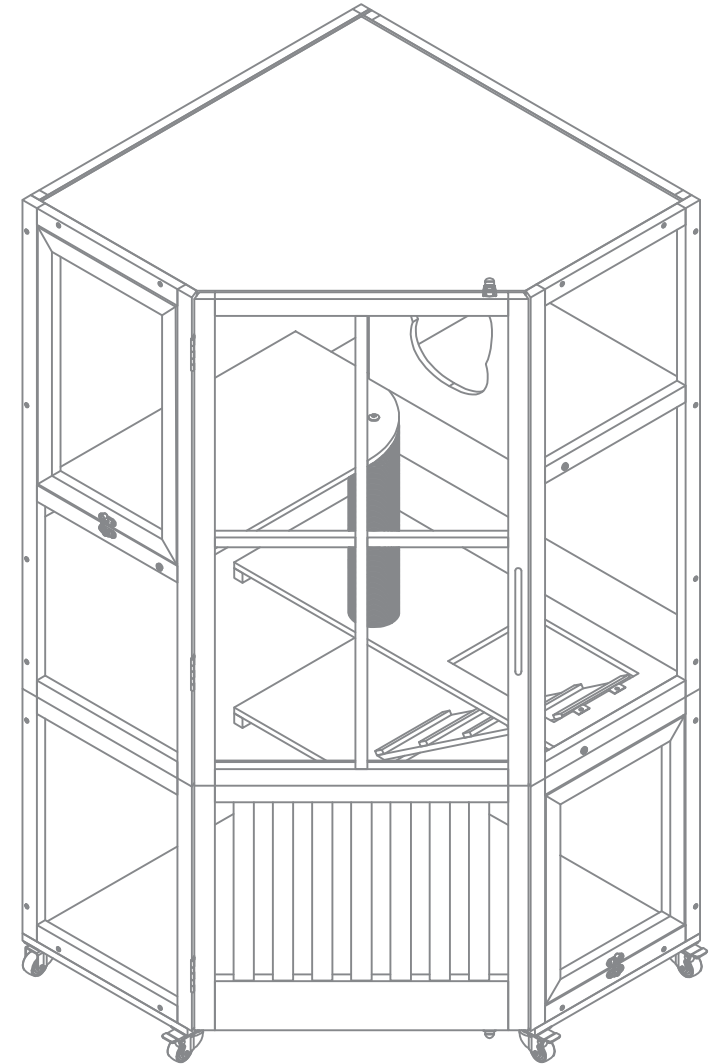

MCombo®

OWNER'S MANUAL

WOODEN CAT HOUSE



I . CATALOG

I . CATALOG	1
II . PRODUCT PRECAUTIONS	1
III . DISCLAIMER	1
IV . INSTALLATION PREPARATION	2
V . ACCESSORIES LIST	3
VI . INSTALLATION INSTRUCTION	5
VII . WARRANTY	14
VIII . RETURN/REPLACEMENT POLICY	15
IX . MCOMBO CUSTOMER CENTER	16

II . PRODUCT PRECAUTIONS



Read and follow the information in the user's manual.



Please keep kids away from small components to ensure safety.



Please ventilate before use.



Do not place overweight items.



Please note that the wood is not chew-proof.



Please clean up water stains and pet excrement in time.



Please handle wood and other accessories properly.

III . DISCLAIMER

We ask that you read this manual completely before assembling and operating your new item. We are not and cannot be held responsible for any damage or injury incurred due to improper or unsafe use of the item. We specifically disclaim responsibility for any bodily injury or property damage that may occur during any use that does not comply with applicable federal, state, or local laws or ordinances. Please keep this manual for future reference.

IV. INSTALLATION PREPARATION

1. Please prepare a carpet or mat to protect your floor. You need to spread out all the accessories.

2. Please prepare a pair of gloves to avoid being scratched by sharp wooden sawdust that may occur during installation.

3. Please open all the boxes to check that the accessories are complete and in good condition (The accessories list in page 3).







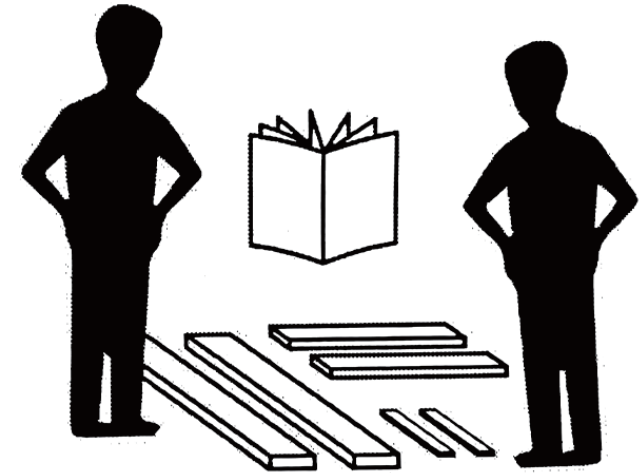

4. The box contains some **small components**, please place them properly before installation to keep them **away from kids** and ensure safety.

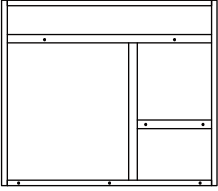
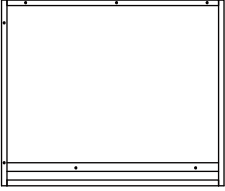
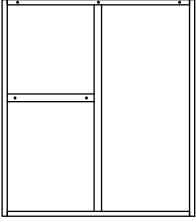
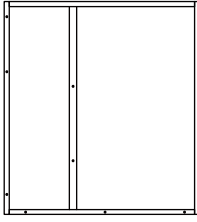
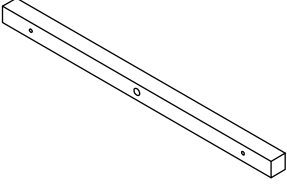
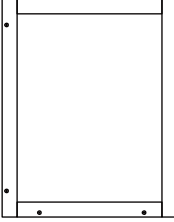
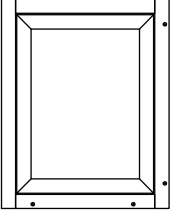
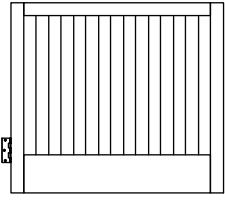
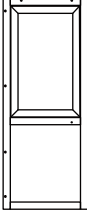
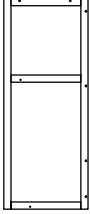
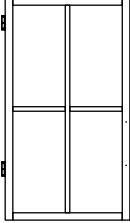
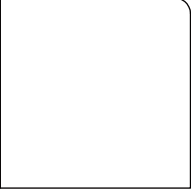
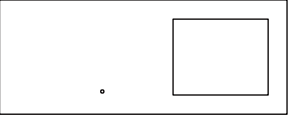
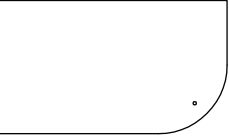
5. If you need to use power tools to install this product, please **set the speed to low speed in advance**. Due to the characteristics of wood products, the use of high speed during installation is probably to damage the wood.

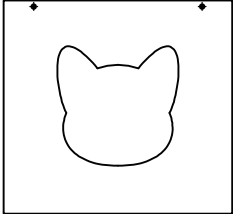
6. When installing, please align all the holes and **do not tighten all the screws first**, otherwise it may make the installation difficult.

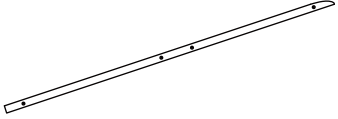
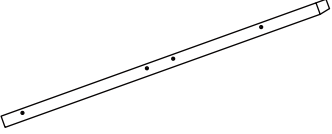

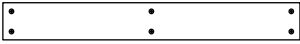
V. Accessories List

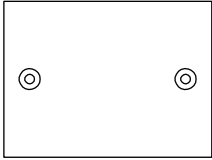
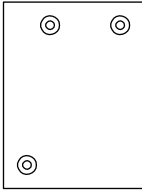
					
A x1	B x1	C x1	D x1	E x1	F x1
					
G x1	H x1	I x1	J x1	K x1	L x1
					
M x1	N x1	O x1	P x1	Q x1	R x1
					
S x1	T x1	U x1	V x2	W x1	X x1







Kindly Notes:

Please open all boxes to check the quantity and condition of accessories.

Q: Is there any broken or missing part?

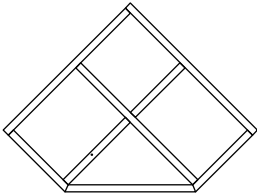
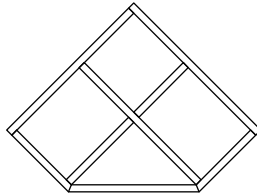
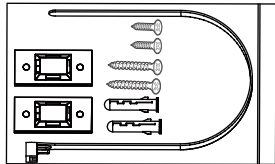
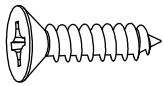
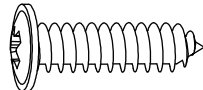
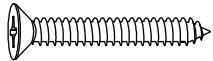
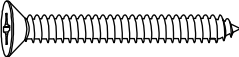
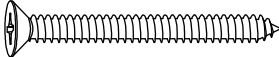
A: If yes, please feel free to contact us (see page 16), we will do our best to assist you to solve the problem as soon as possible.

V. Accessories List

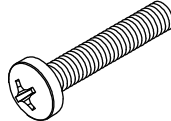
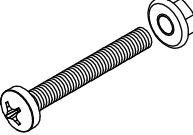
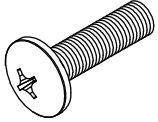
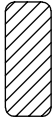
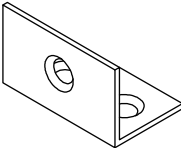
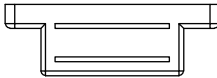
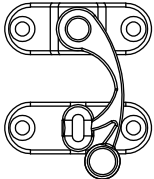
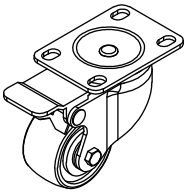
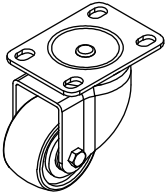
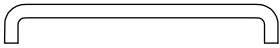
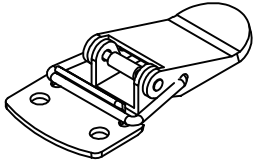
 <p>Y x1</p>	 <p>Z x1</p>	 <p>AA x3</p>	 <p>M3*12mm ① x 35+2PCS</p>	 <p>M3*14mm ② x 24+2PCS</p>	 <p>M3.5*20mm ③ x 6+1PC</p>
 <p>M3.5*25mm ④ x 4+1PC</p>	 <p>M3.5*30mm ⑤ x 21+2PCS</p>	 <p>M3.5*35mm ⑥ x 22+2PCS</p>	 <p>M3.5*40mm ⑦ x 17+1PC</p>	 <p>M3.5*50mm ⑧ x 2PCS</p>	 <p>M4*22mm ⑨ x 2PCS</p>
 <p>M6*45mm ⑩ x 17+1PC</p>	 <p>M8*30mm ⑪ x 2PCS</p>	<p>wood stick</p>  <p>Ø8*20mm ⑫ x 38+3PCS</p>	 <p>⑬ x 2PCS</p>	 <p>⑭ x 2PCS</p>	 <p>⑮ x 2PCS</p>
 <p>⑯ x 3PCS</p>	 <p>⑰ x 3PCS</p>	 <p>⑱ x 1PC</p>	 <p>⑲ x 2PCS</p>		



Kindly Notes:

Please open all boxes to check the quantity and condition of accessories.

Q: Is there any broken or missing part?

A: If yes, please feel free to contact us (see page 16), we will do our best to assist you to solve the problem as soon as possible.

VI . INSTALLATION INSTRUCTION

Q: How to deal with parts without holes?

A: Do not worry! Due to slight deviation during installation, only pilot holes are marked. Please align the parts and install them according to the manual.

STEP 1

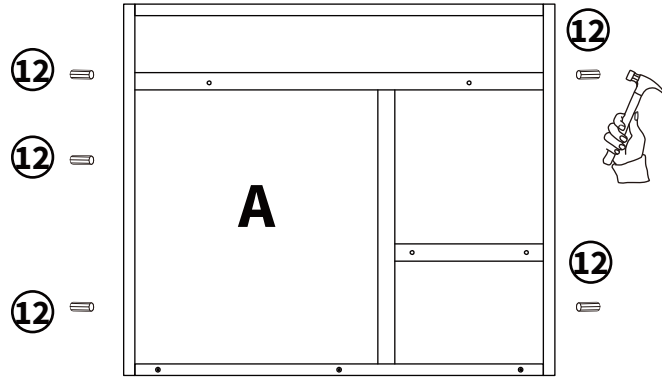

STEP 2

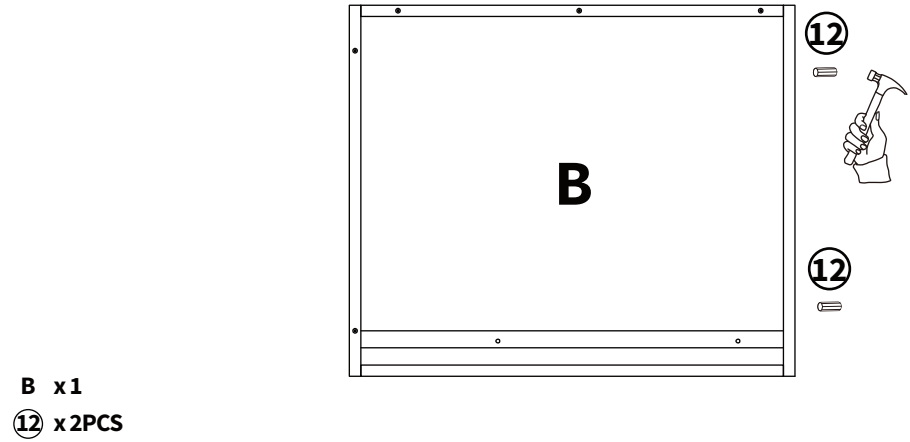

STEP 3

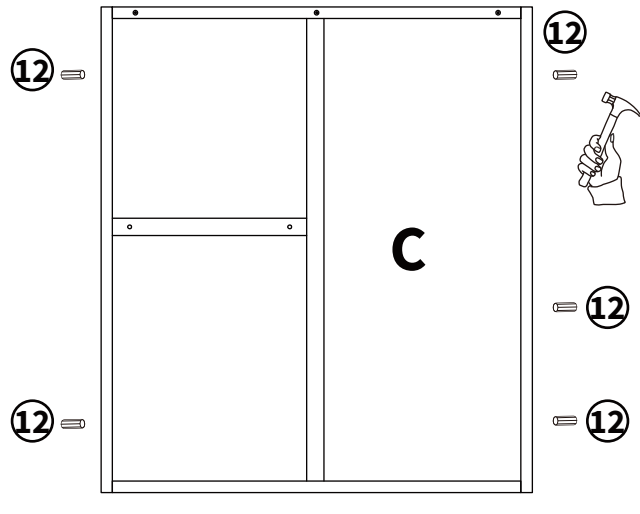

STEP 4

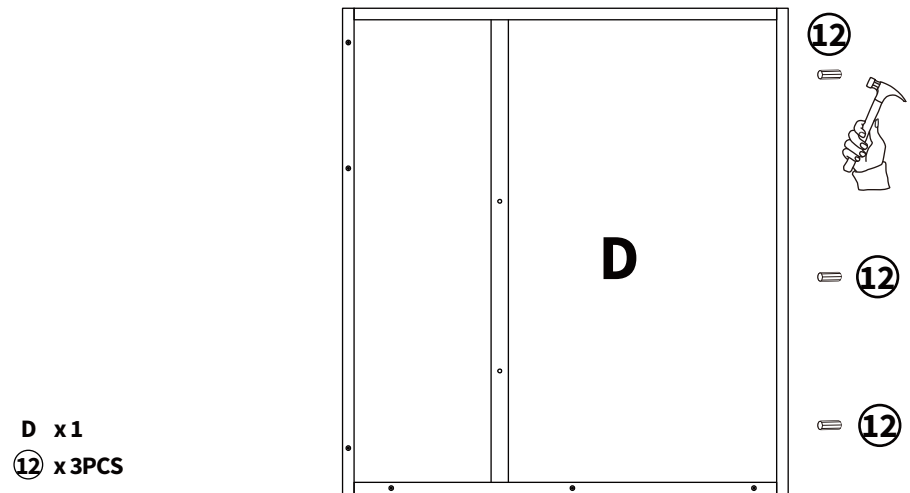

VI . INSTALLATION INSTRUCTION

Q: How to deal with parts without holes?

A: Do not worry! Due to slight deviation during installation, only pilot holes are marked. Please align the parts and install them according to the manual.

STEP 5

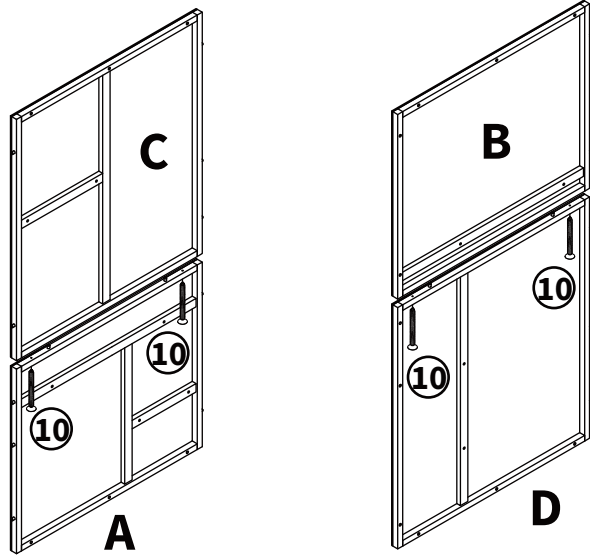

10 x 4PCS

STEP 6

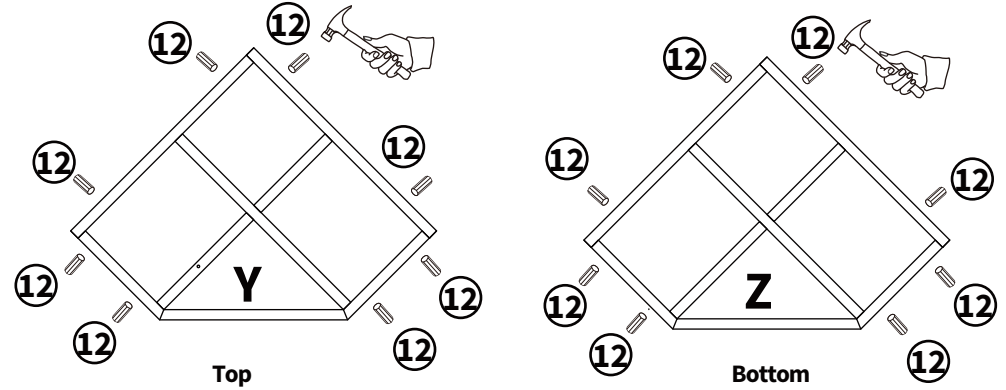

Y x 1

Z x 1

12 x 16PCS

STEP 7

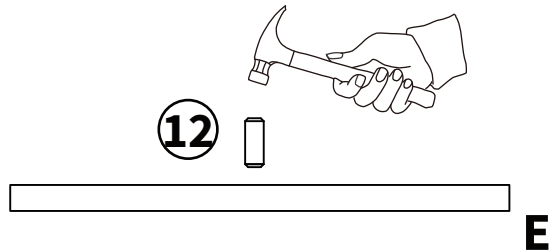

E x 1

12 x 1PCS

STEP 8

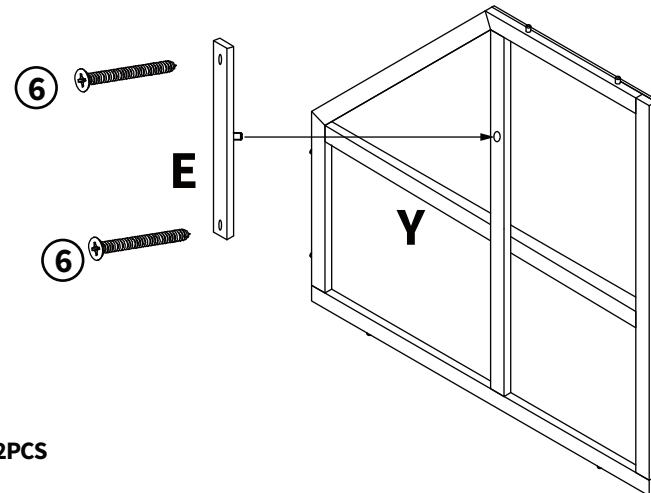

6 x 2PCS

VI . INSTALLATION INSTRUCTION

Q: How to deal with parts without holes?

A: Do not worry! Due to slight deviation during installation, only pilot holes are marked. Please align the parts and install them according to the manual.

STEP 9

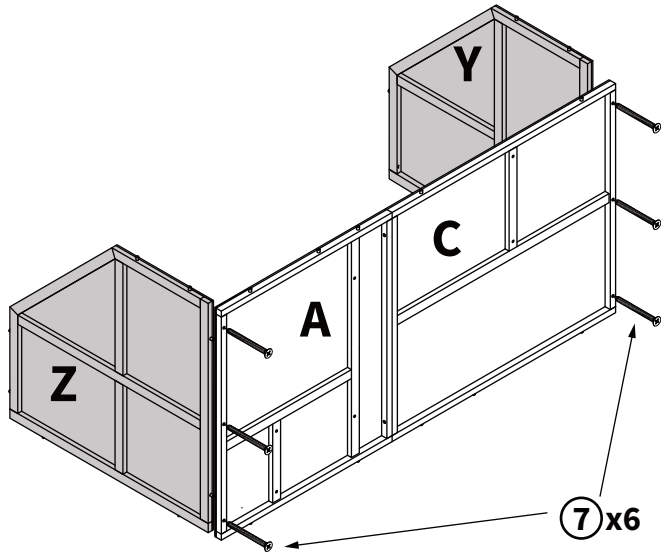

STEP 10

Please note:

Flip the previous step 90° to the right.

⑦ x11PCS

⑦ x11

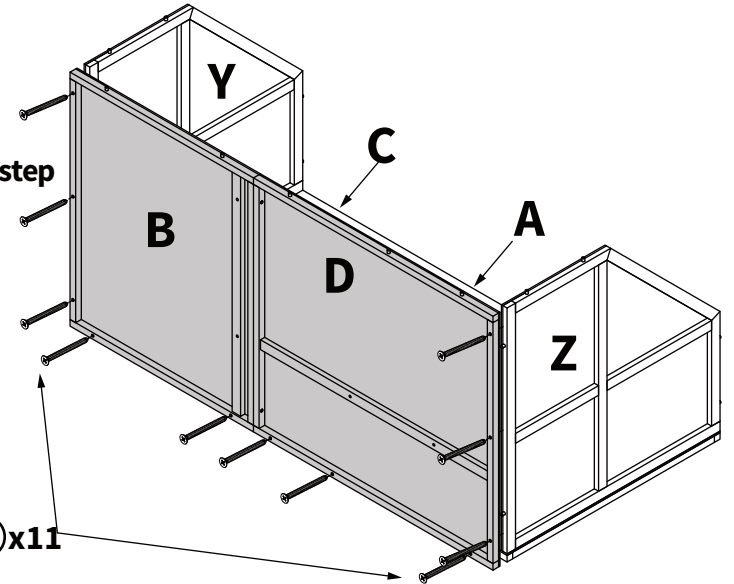

STEP 11

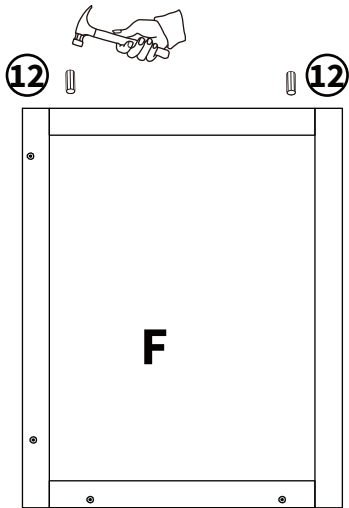

STEP 12

I x1

⑥ x10PCS

⑥ x10

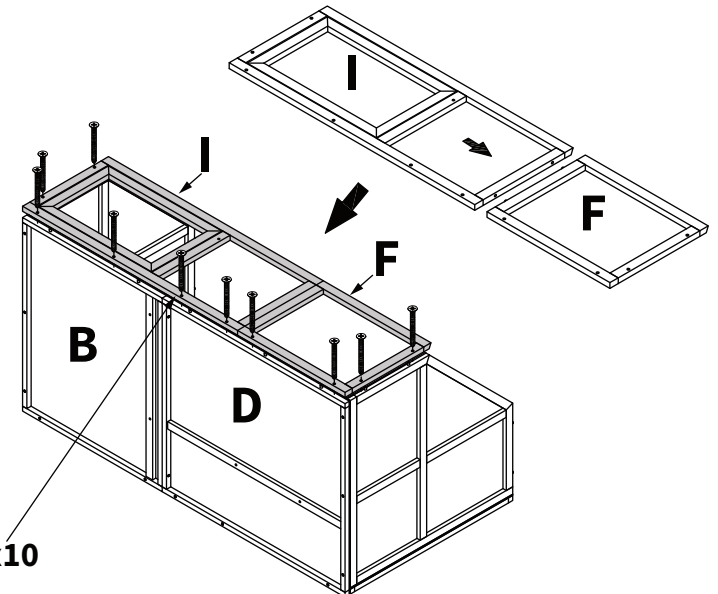

VI . INSTALLATION INSTRUCTION

Q: How to deal with parts without holes?

A: Do not worry! Due to slight deviation during installation, only pilot holes are marked. Please align the parts and install them according to the manual.

STEP 13

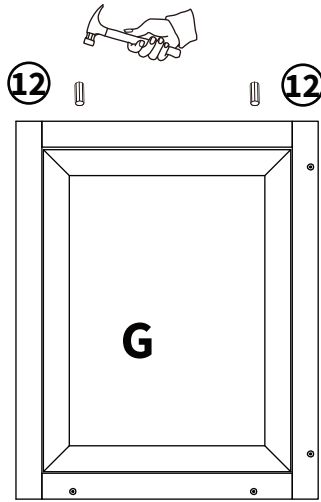

G x1
 12 x2PCS

STEP 14

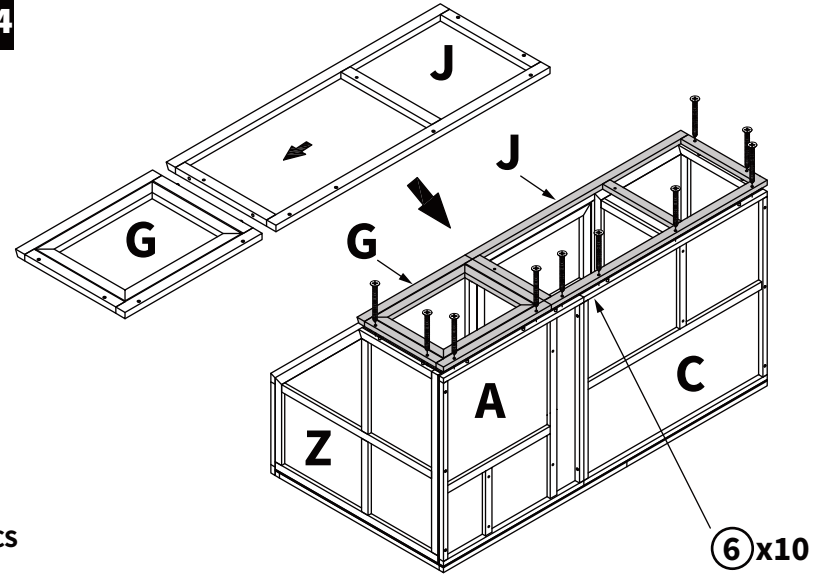

J x1
 6 x10PCS

STEP 15

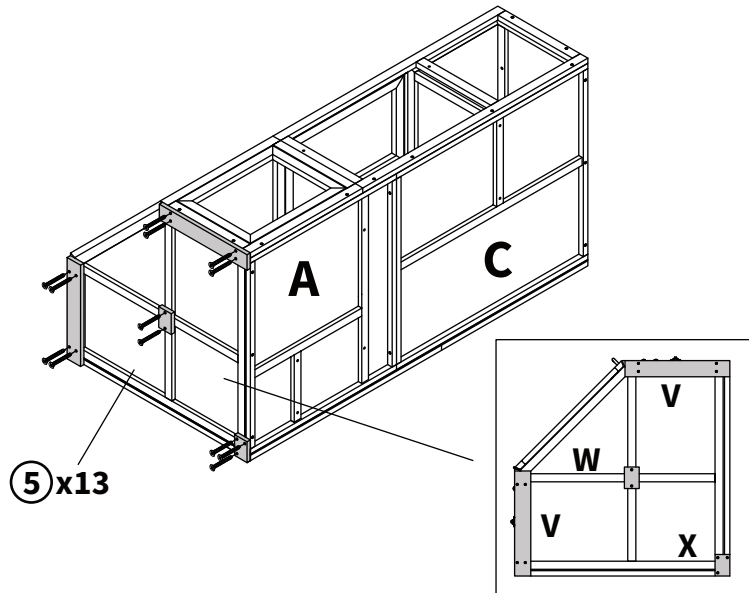

V x2
 W x1
 X x1
 5 x13PCS

STEP 16

Please note:

Parts #16 need to be installed on FRONT side.

2 x24PCS
 16 x3PCS
 17 x3PCS

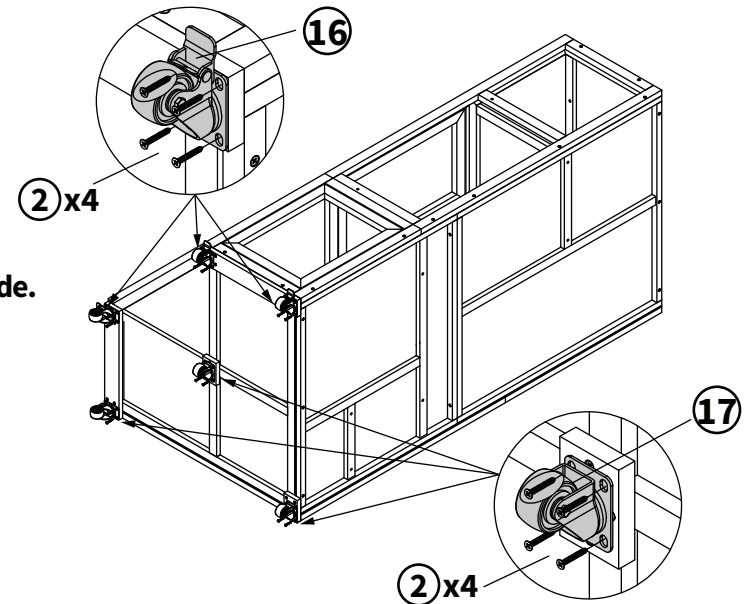

VI . INSTALLATION INSTRUCTION

Q: How to deal with parts without holes?

A: Do not worry! Due to slight deviation during installation, only pilot holes are marked. Please align the parts and install them according to the manual.

STEP 17

Please note:

The direction of part
#R & part #S.

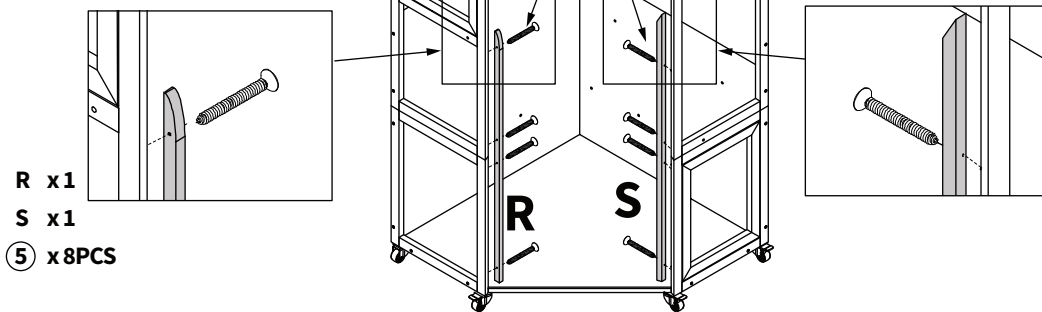

STEP 18

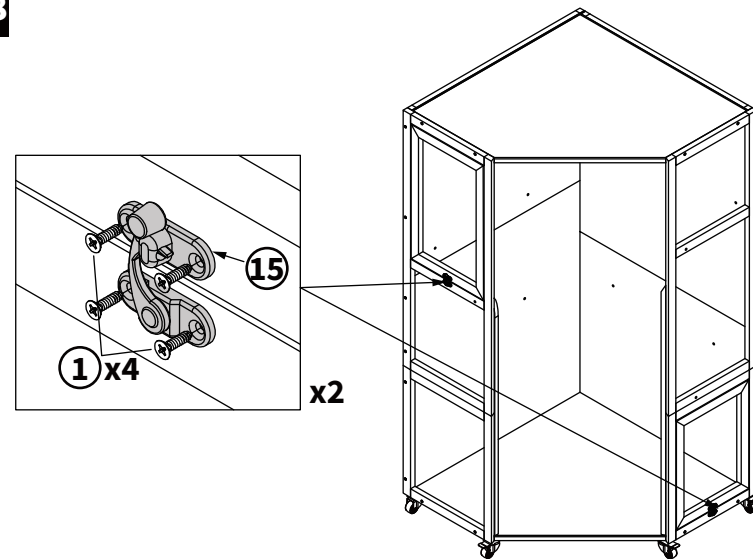

STEP 19

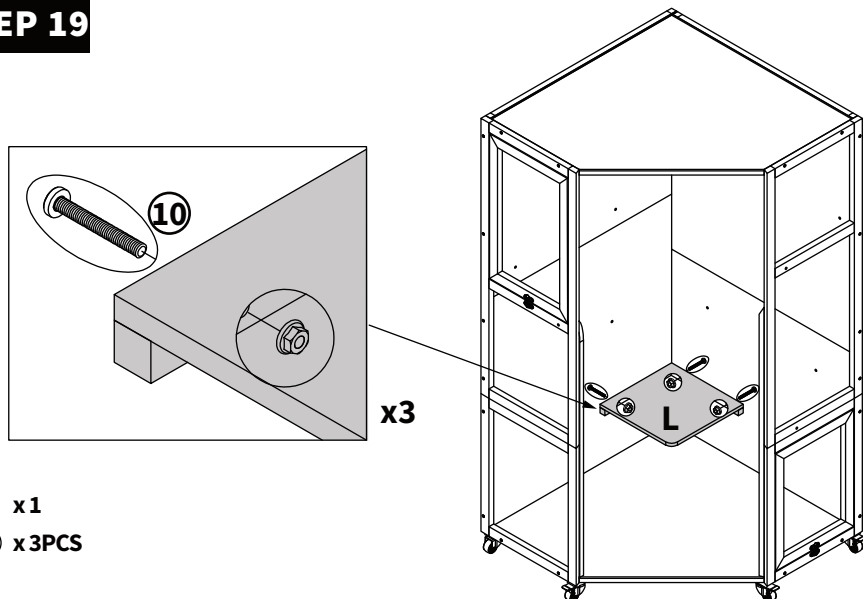

STEP 20

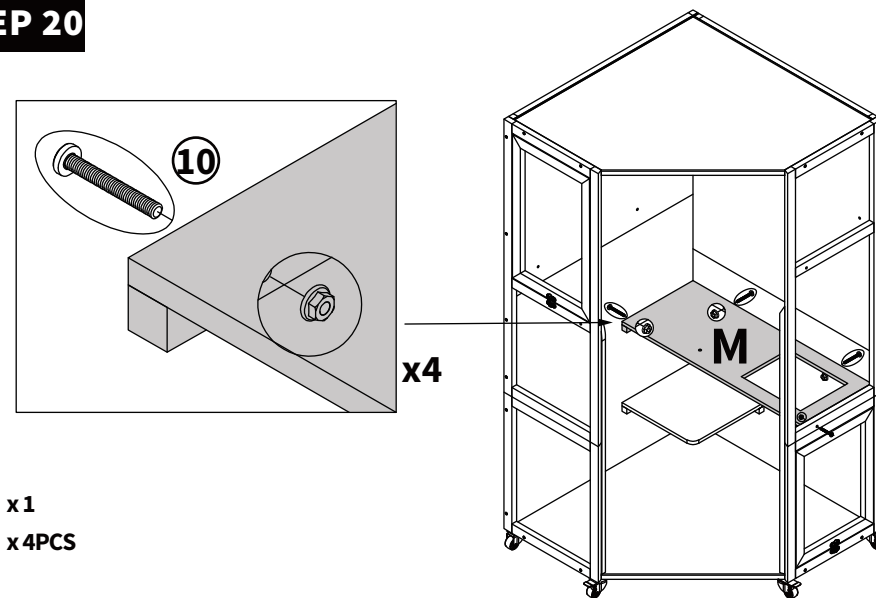

VI . INSTALLATION INSTRUCTION

Q: How to deal with parts without holes?

A: Do not worry! Due to slight deviation during installation, only pilot holes are marked. Please align the parts and install them according to the manual.

STEP 21

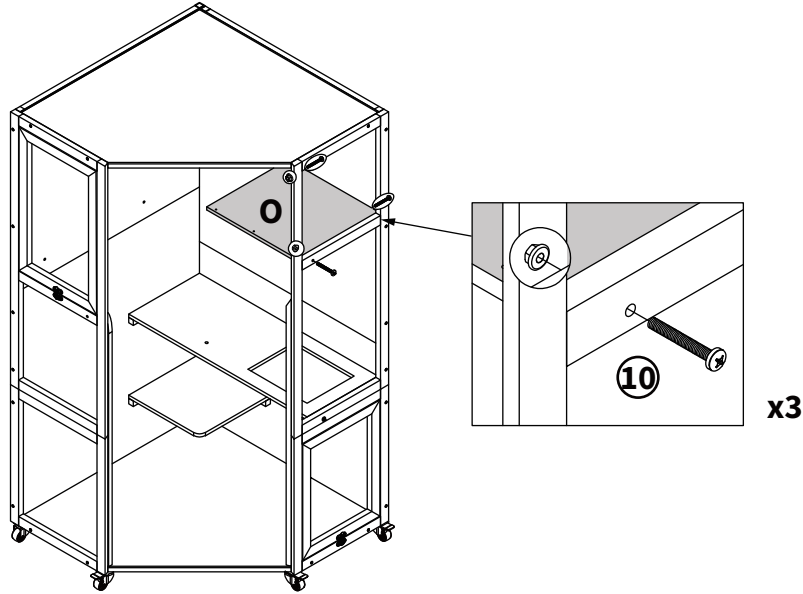

O x1
⑩ x3PCS

STEP 22

Please note:

Install the top
④ x2 PCS first.

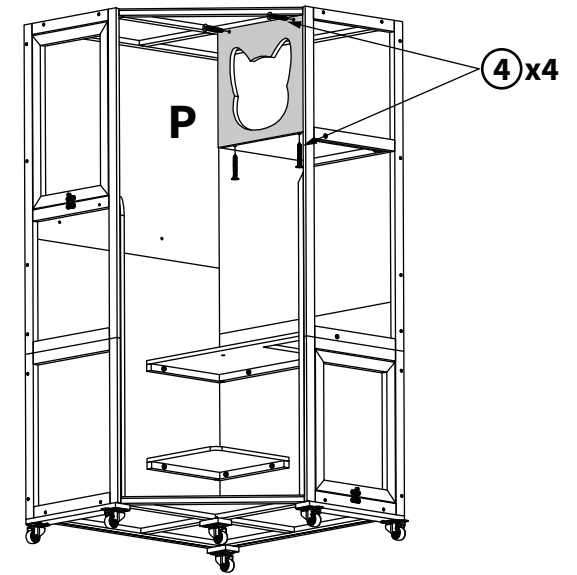

P x1
④ x4PCS

STEP 23

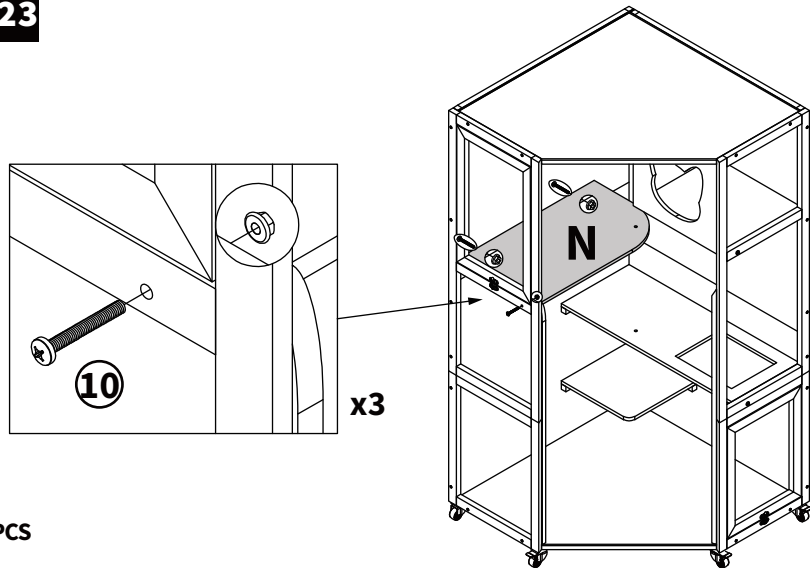

N x1
⑩ x3PCS

STEP 24

Q x1
T x1
① x10PCS
⑪ x2 PCS
⑬ x2PCS
⑭ x2PCS

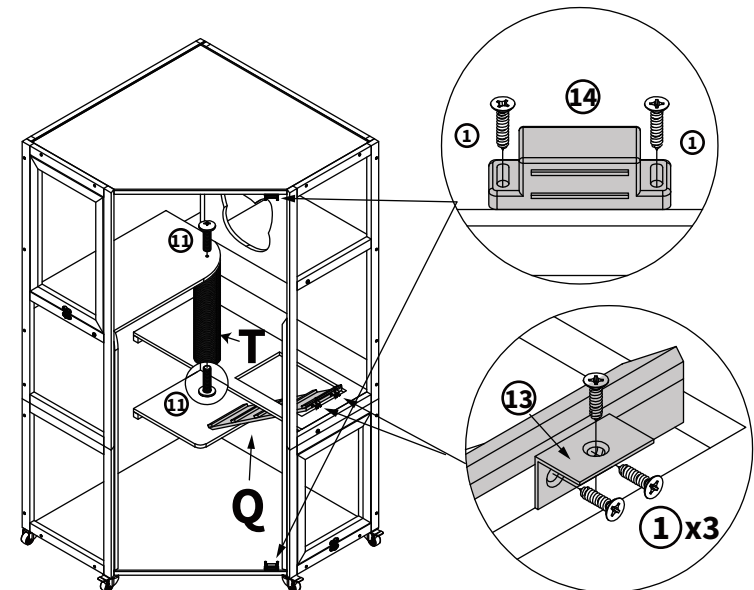

VI . INSTALLATION INSTRUCTION

Q: How to deal with parts without holes?

A: Do not worry! Due to slight deviation during installation, only pilot holes are marked. Please align the parts and install them according to the manual.

STEP 25

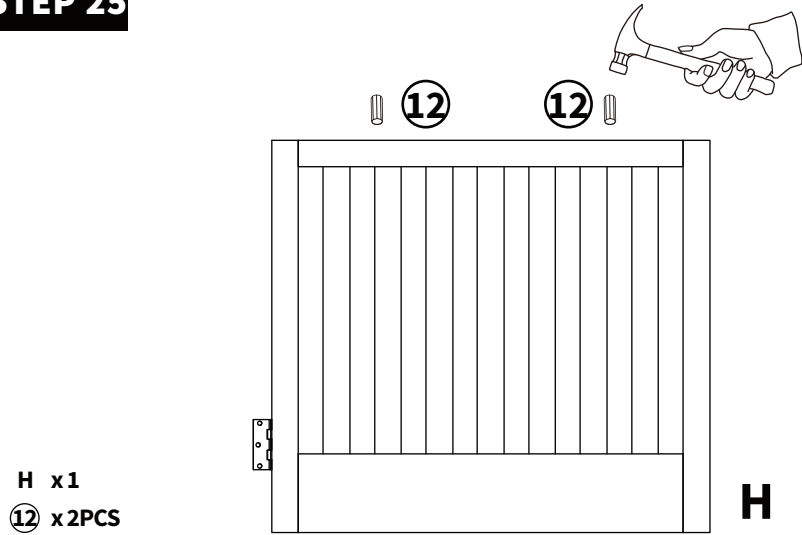

STEP 26

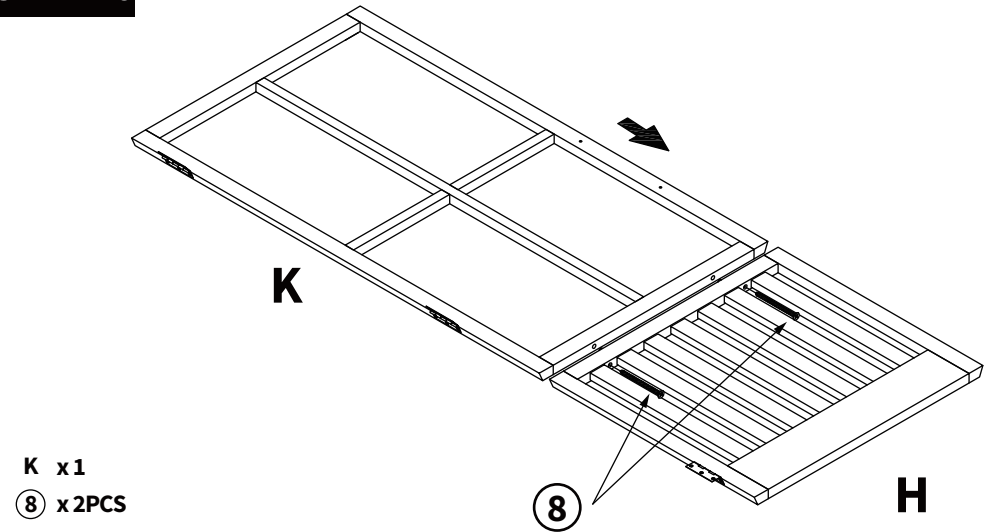

STEP 27

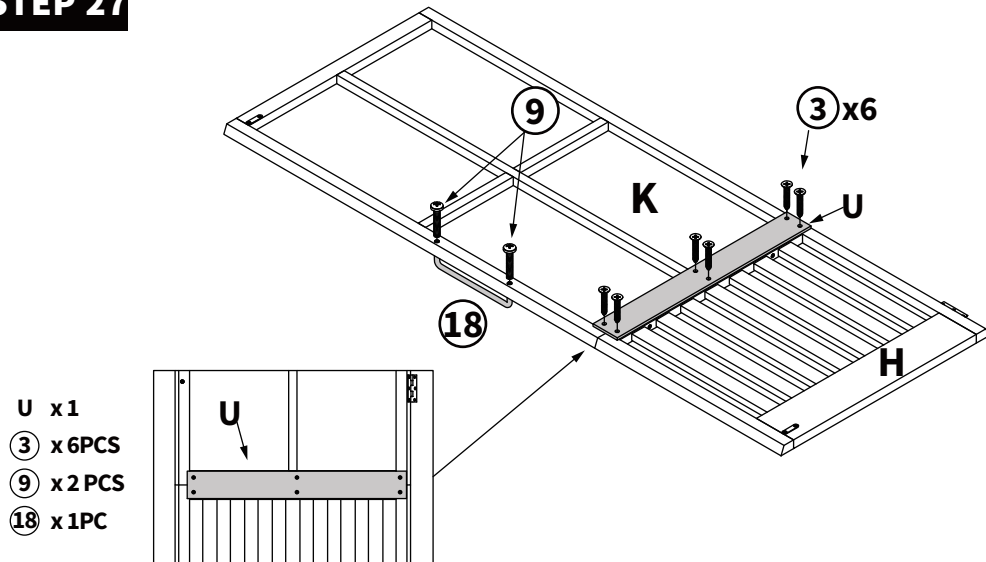

STEP 28

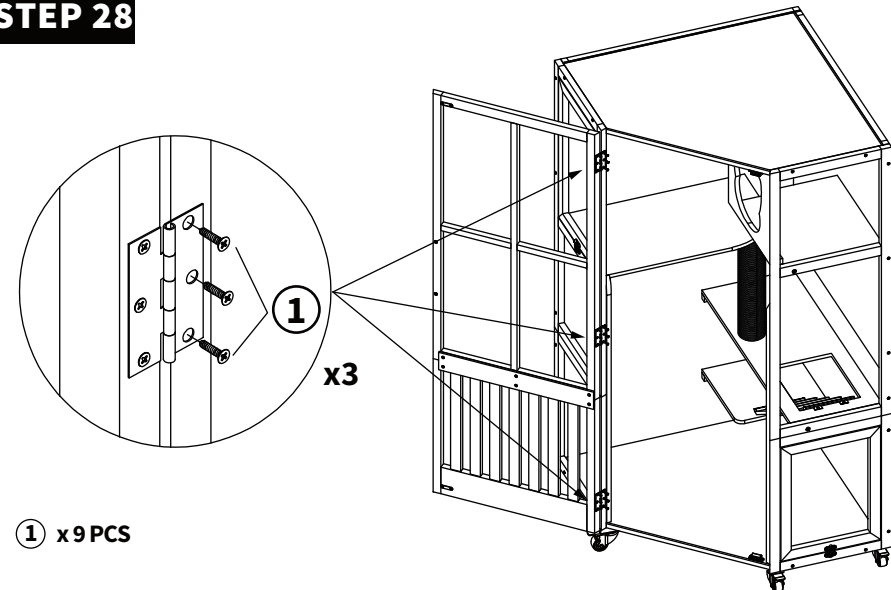

VI . INSTALLATION INSTRUCTION

Q: How to deal with parts without holes?



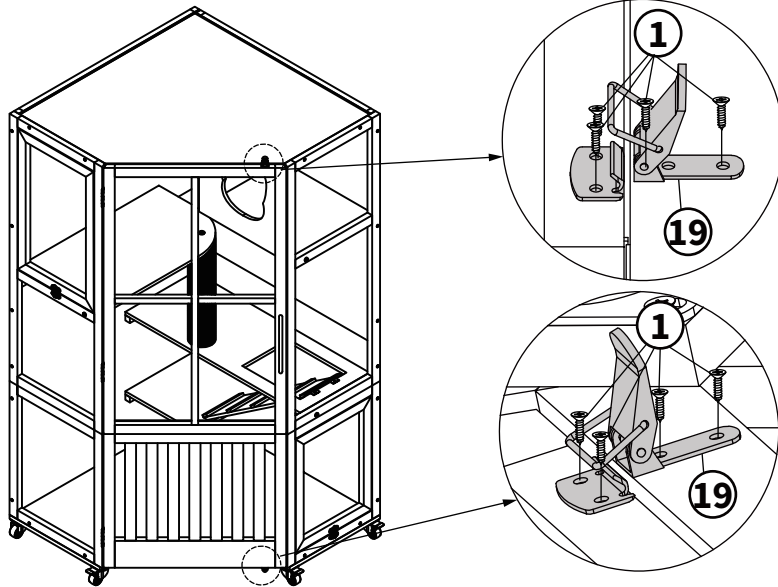

A: Do not worry! Due to slight deviation during installation, only pilot holes are marked. Please align the parts and install them according to the manual.

STEP 29



① x 8 PCS
⑱ x 2 PCS

STEP 30

	x3	
	x3	✓
	x6	✓
	x6	✓
	x6	



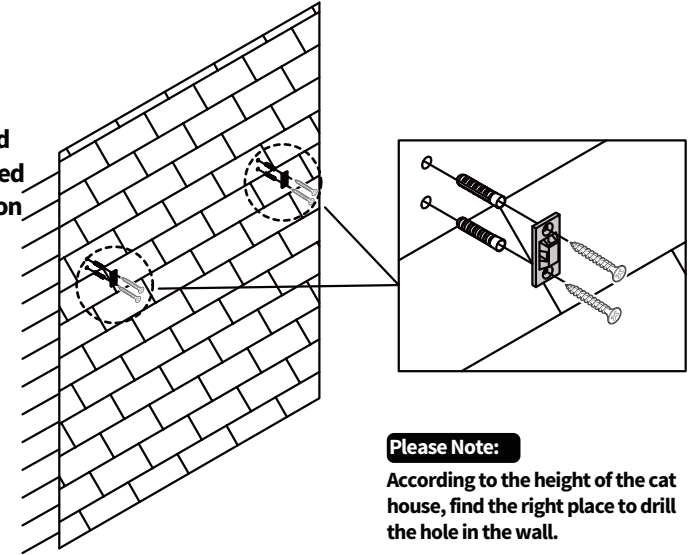

!
The parts marked with ✓ are required for this installation step.



Please Note:
According to the height of the cat house, find the right place to drill the hole in the wall.

AA x 3

STEP 31



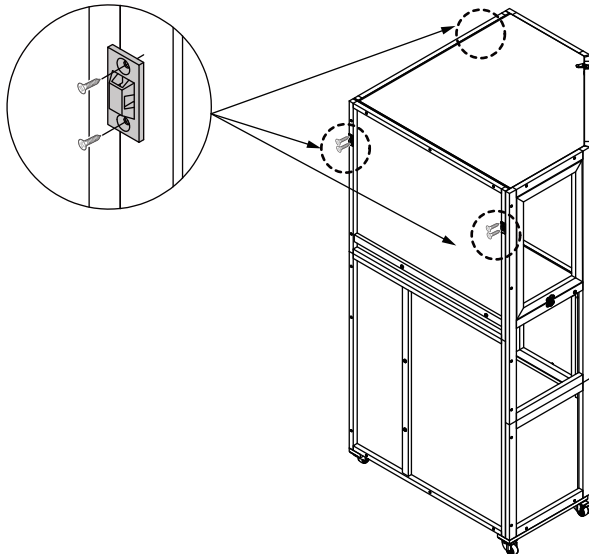

	x3	✓
	x3	
	x6	
	x6	
	x6	

!
The parts marked with ✓ are required for this installation step.



AA x 3

STEP 32

	x3	✓
	x3	
	x6	
	x6	
	x6	

!
The parts marked with ✓ are required for this installation step.

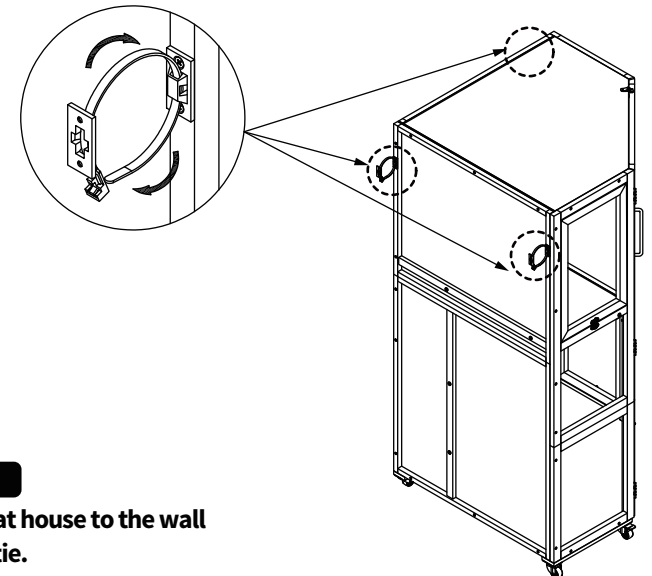

Please Note:
Secure the cat house to the wall with plastic tie.

AA x 3

VI . INSTALLATION INSTRUCTION

Q: How to deal with parts without holes?

A: Do not worry! Due to slight deviation during installation, only pilot holes are marked. Please align the parts and install them according to the manual.

STEP 33

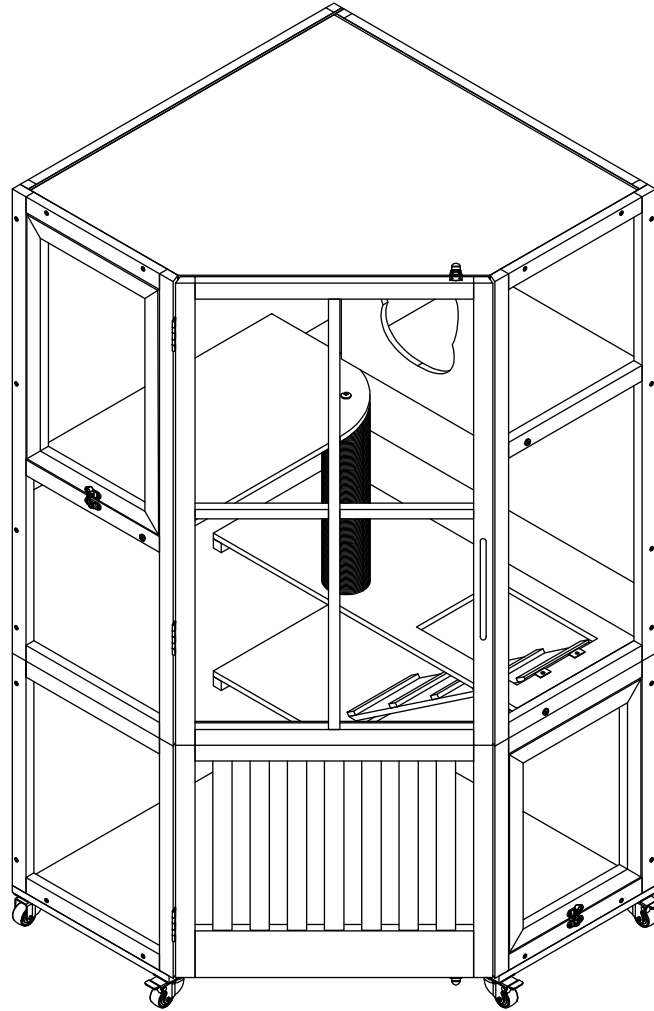

FINISH

VII . WARRANTY

Wood	1 Year
Hardware	6 months

Limitations Applicable to All Warranties

All warranties begin on the date of delivery.

All warranties are to the original purchaser

from MCombo /ExacMe ONLY.

WARRANTY DETAIL EXPLANATION

- MCombo will replace the defective parts or send a replacement item provided that the warranty parts have not been subjected to misuse, abuse, or improper service by the consumer, for example, damaged part arising in consequence of negligence or improper operation.

- Exclusions also include components with damage caused by:

Contamination

Abuse, misuse, accident or negligence

Commercial use, or use other than normal

Improper operation maintenance, or storage

- MCombo will pay standard shipping rates on all warranted parts for the first year. We can also sell you the replacement part for a discount price when your item is out of warranty policy.

VIII . RETURN/REPLACEMENT POLICY

MCOMBO: All items come with a 30-day return/replace policy during this time we will cover the shipping cost of return and replacement for a defective and damaged item, and provide pre-paid return label or pick-up service for customer's convenience.

Note: Please disassemble the item before you return it, otherwise there will be a huge cost as oversized and it could even exceed your order amount.

Please do not purchase return labels for a damaged defective item by yourself.



If you have any problem to return the item please contact us immediately we will do our best to help you.

MCombo is not responsible for the returns that the customer bought by mistake or changed their mind and other non-quality issues. But we can help customers arrange pick-up service at a reasonable price.

Note: The customer is responsible for freight costs unless the item is defective items returned due to being refused delivery by the customer or deemed undeliverable by freight carrier are subject to fees for a 20% restocking fee.

IX . MCOMBO CUSTOMER CENTER

If for any reason we have fallen short of your expectations or if you have any questions and suggestions please refer to the following to contact us, we will do our best to work with you to make sure you are entirely satisfied.

	1-323-597-1109 (Monday–Friday 8:00 a.m. – 4:00 p.m. TIME ZONE: PST)
	sales@mcombo.com (Respond within 24 hours)
	Newacme 3980 Premier Ave Memphis, TN, 38118

If there is any problem with the product, how to solve it?

In order to efficiently help you solve the problem, please let us know your **order number, the part number of the defective/missing part, the quantity of the issue parts, and send some pictures** when contacting us. They can effectively assist us to solve the problem for you quickly.

Please rest assured, you will receive a reply within 24 hours.

MCombo®



Mcombo.com



Amazon.com/mcombo

Newacme LLC, 2808 Vail Ave, Commerce, CA, 90040
sales@mcombo.com
1-323-597-1109 (8:00 a.m. - 4:00 p.m. (Monday - Friday) TIME ZONE: PST)