

# RAVENNA 02

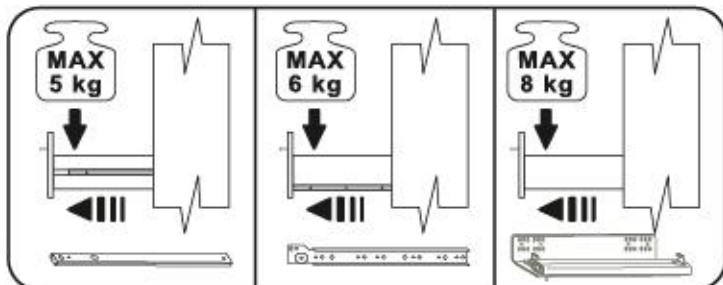

# RAVENNA 02

max.

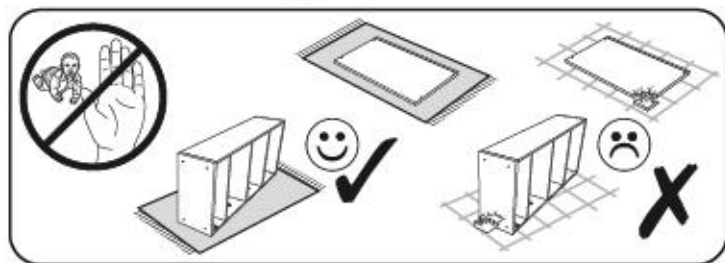
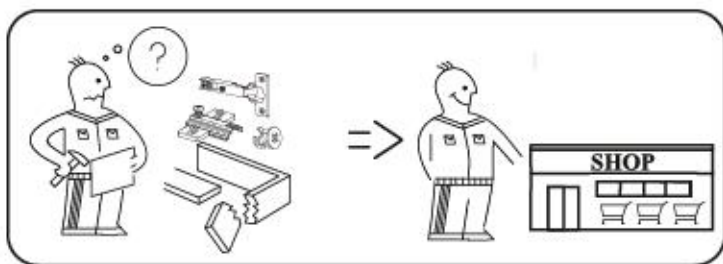
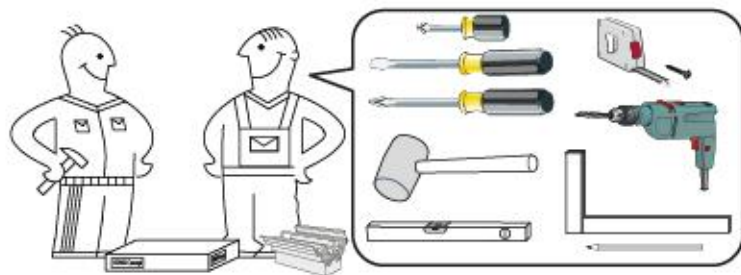
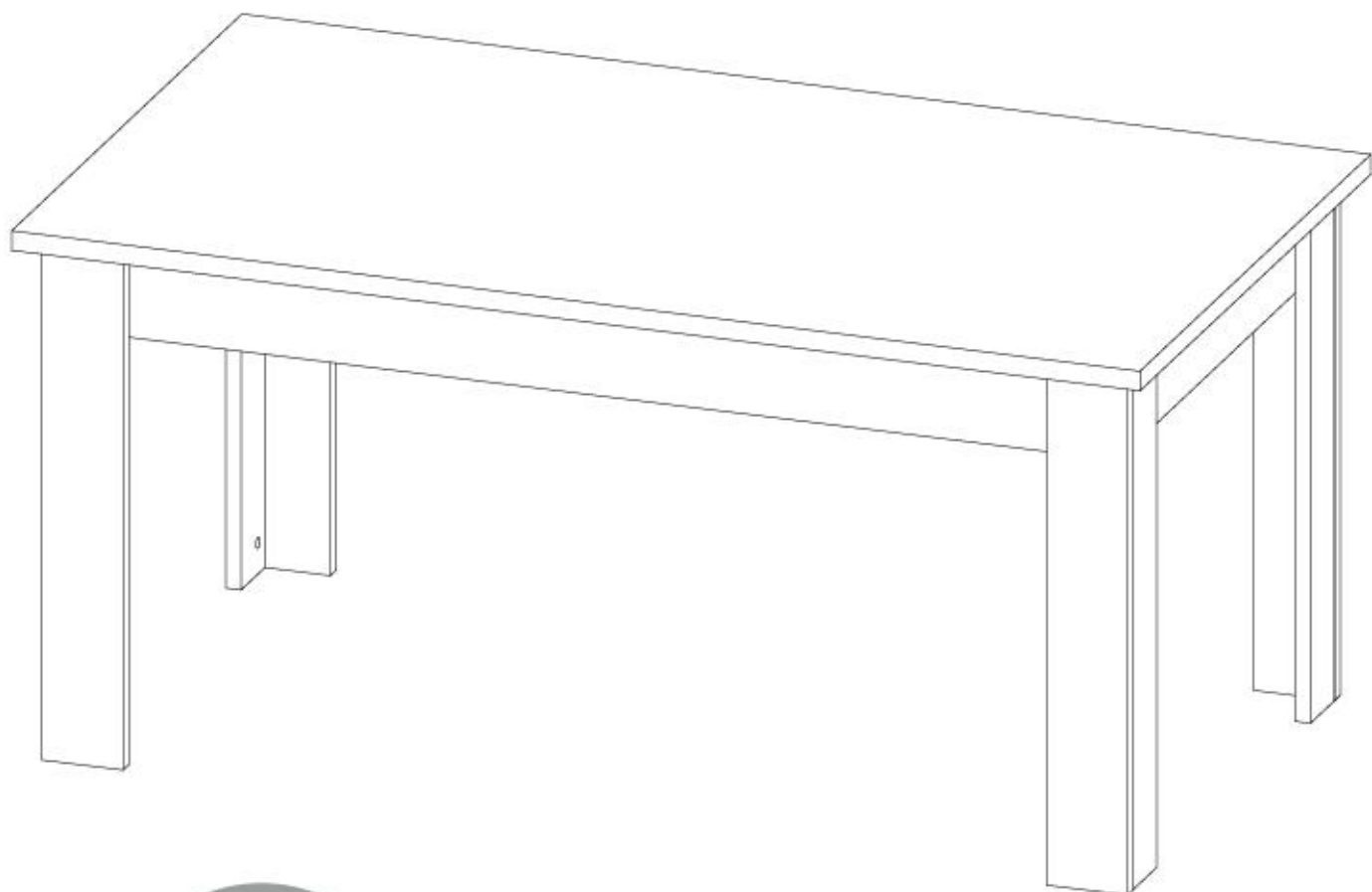

HC 1

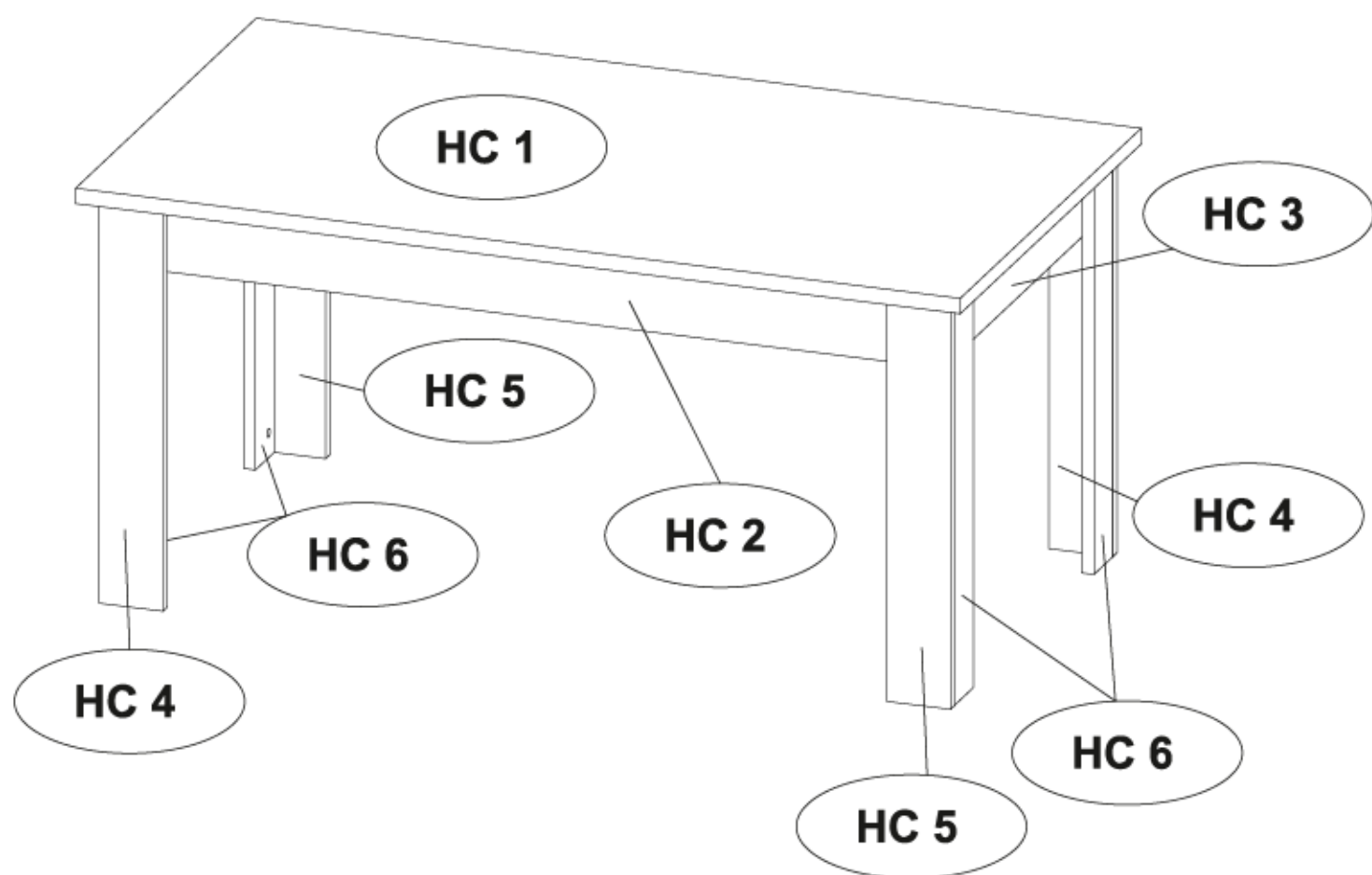

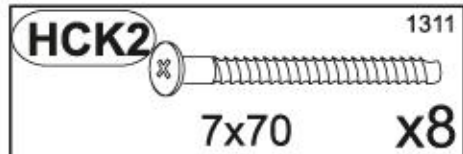
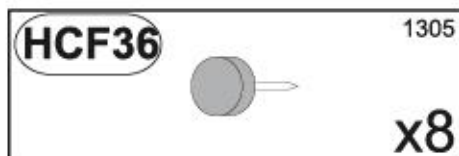
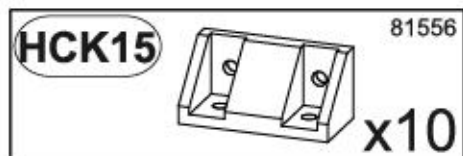
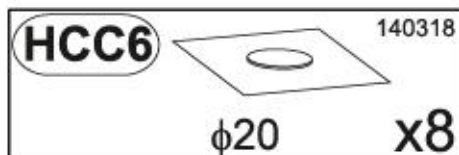
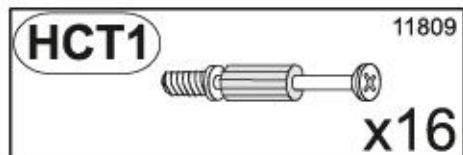
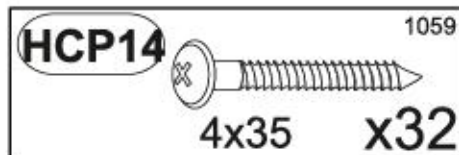
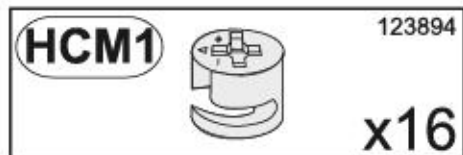
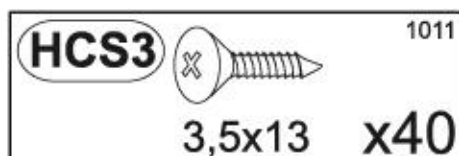
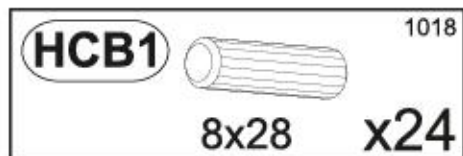

HC 1	x1	1596	896	28	1/1
HC 2	x2	1446	124	22	1/1
HC 3	x2	783	124	22	1/1
HC 4	x2	729	115	22	1/1
HC 5	x2	729	115	22	1/1
HC 6	x4	729	93	22	1/1

# RAVENNA 02



1

HCB1		1018
	8x28	x24
HCM1		123894
		x16
HCT1		11809
		x12

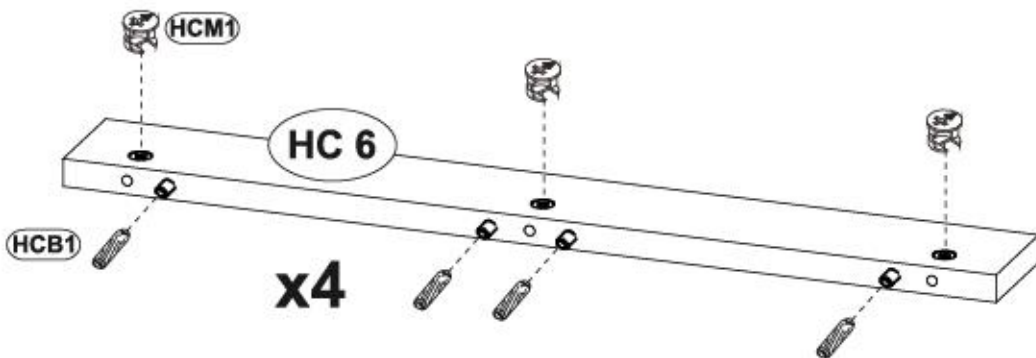
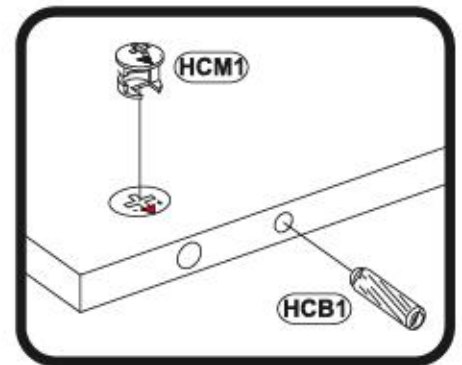
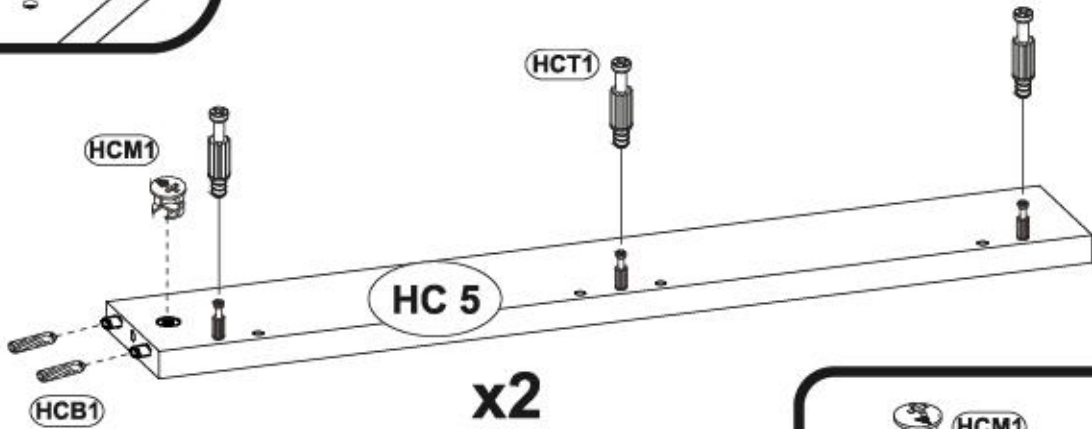
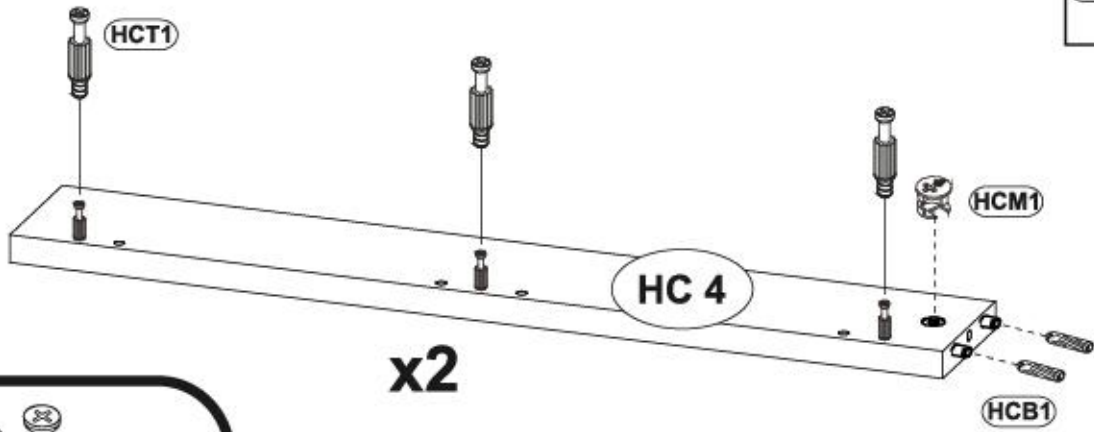

2

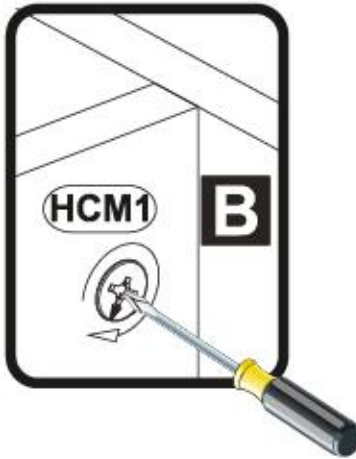
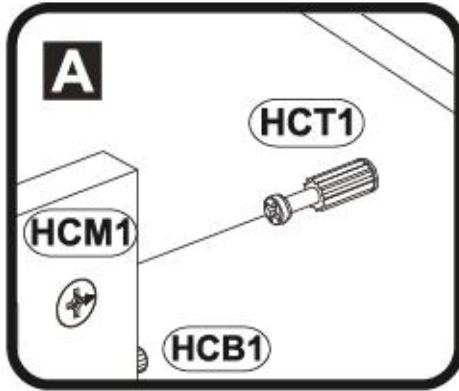
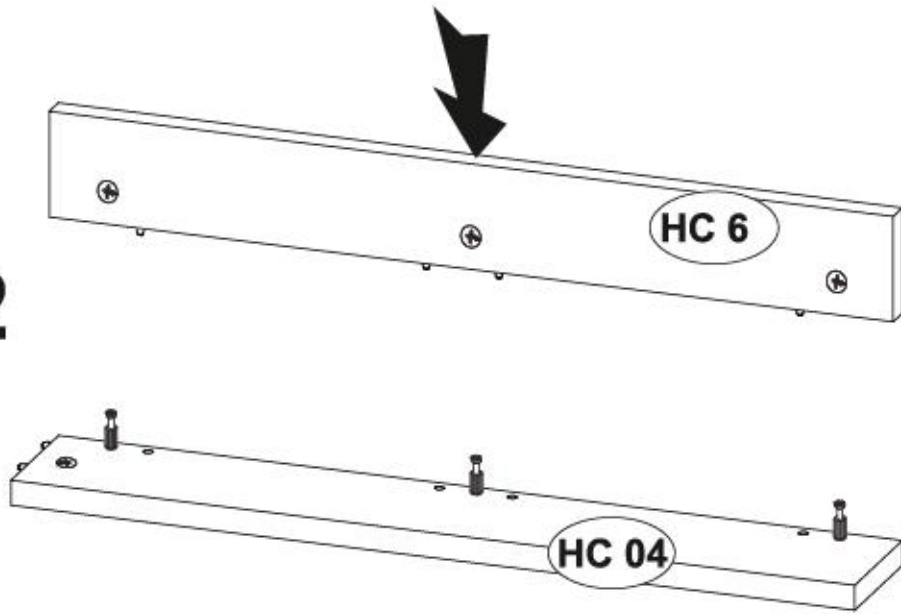

x2

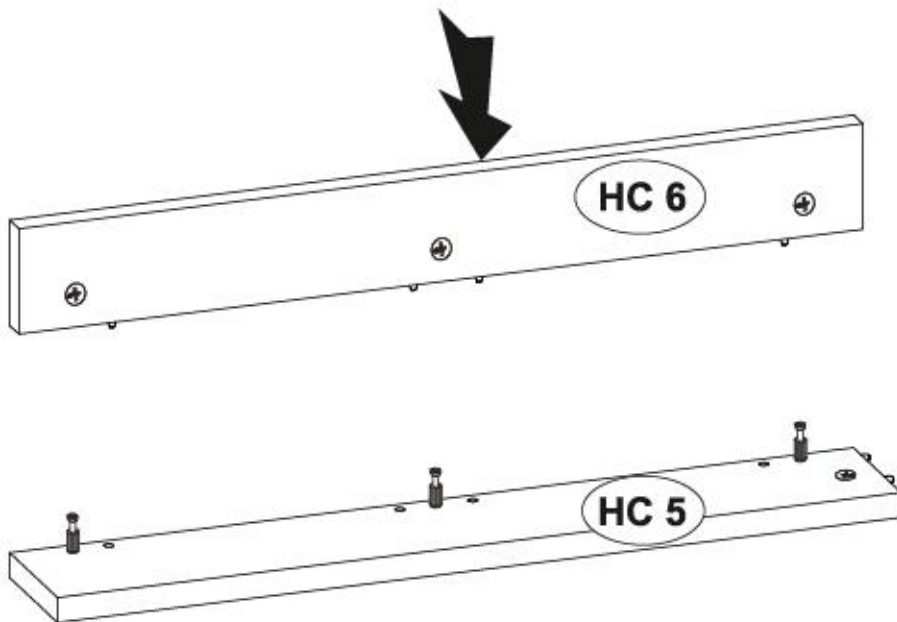

x2



3

HCT1	11809
	x4
HCK15	81569
	x10
HCS3	1011
	3,5x13 x20

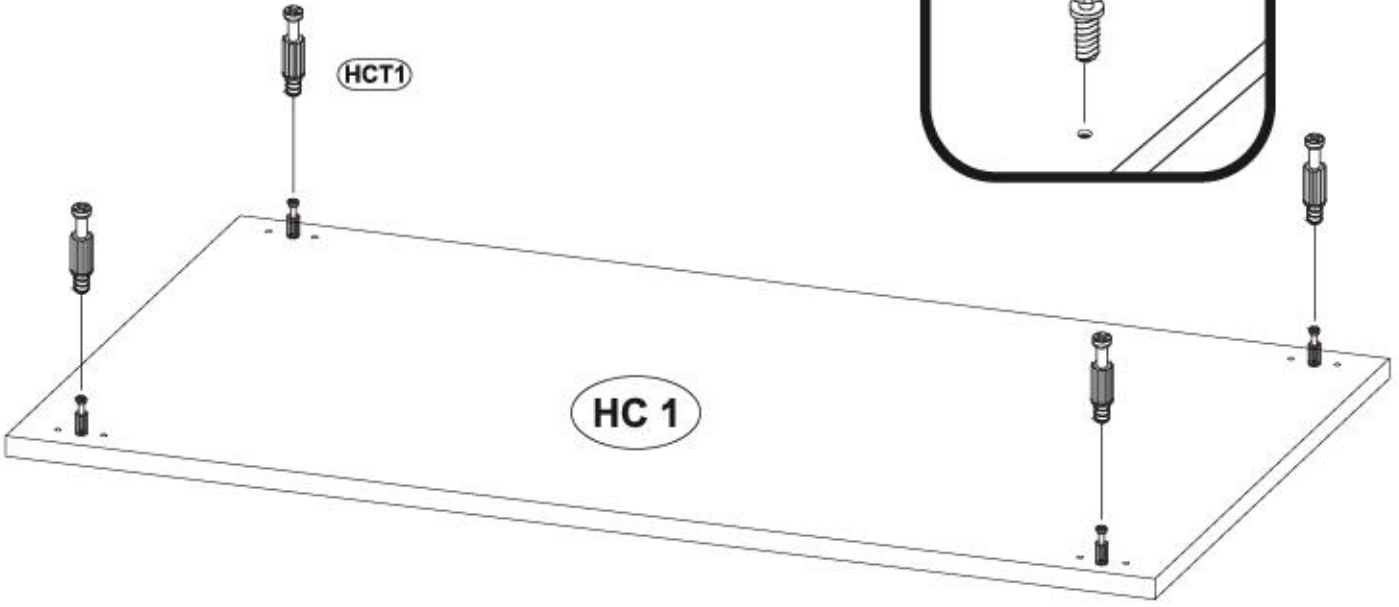
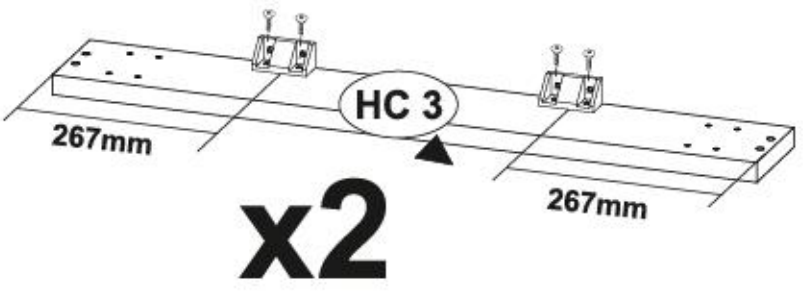
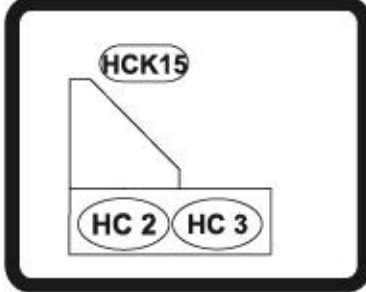
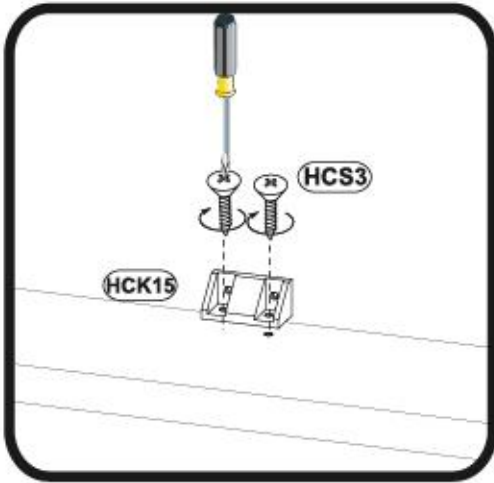
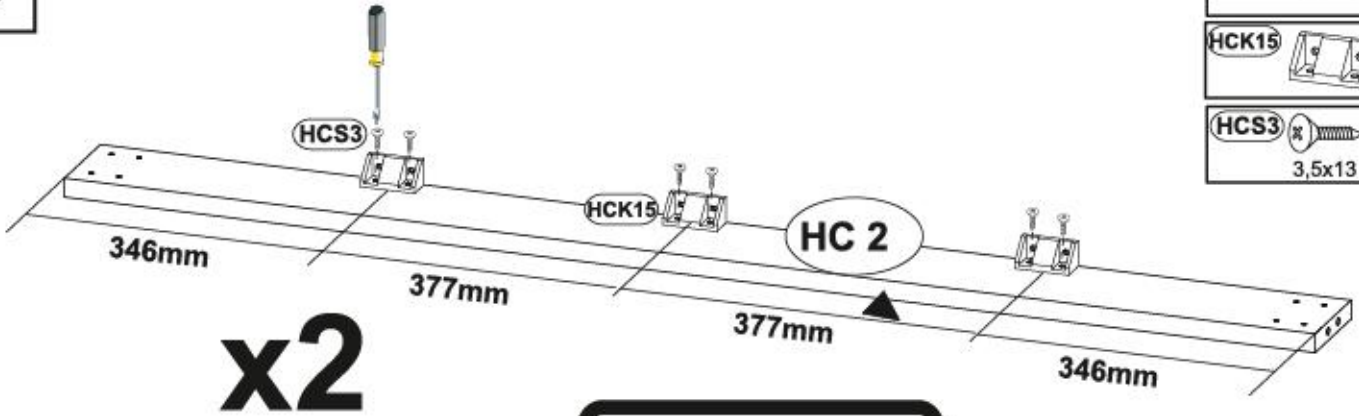

4



HCK2 13111  
7x70 X8

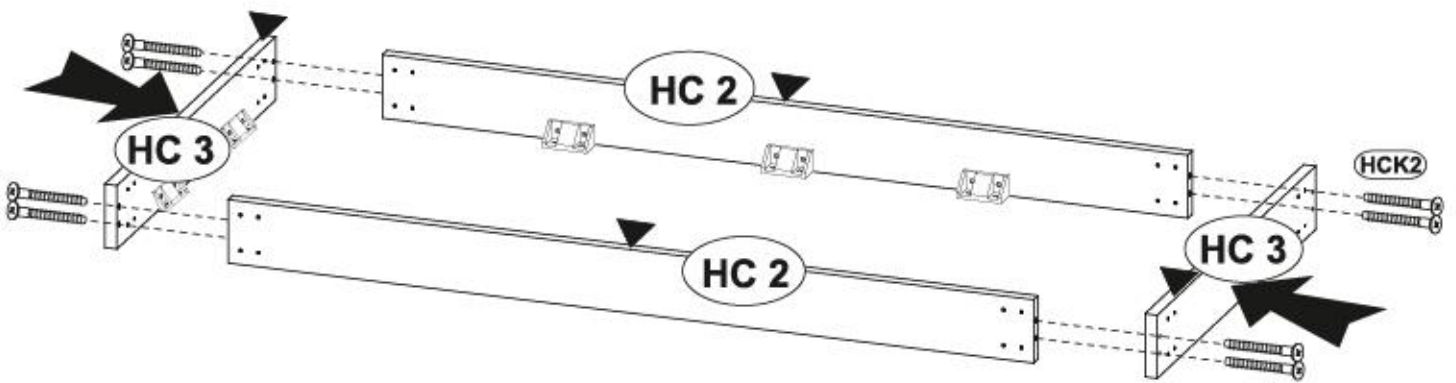
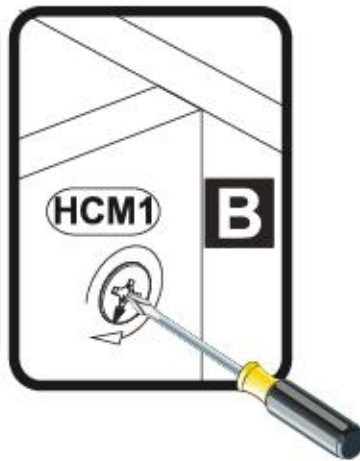
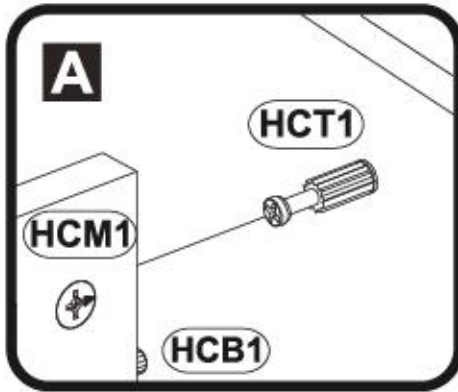
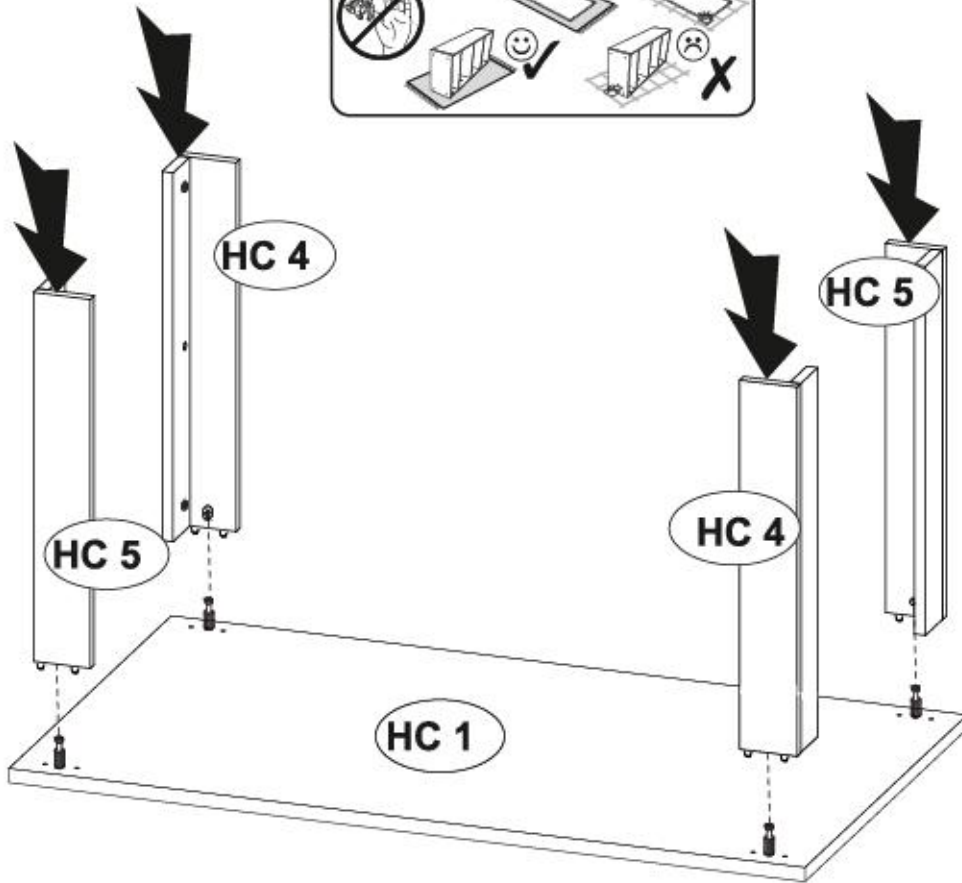



5



<b>HCS3</b> 1011		3,5x13	x20
<b>HCP14</b> 1059		4x35	x32
<b>HCC6</b> 140310		φ20	x8
<b>HCF36</b> 1956			x8

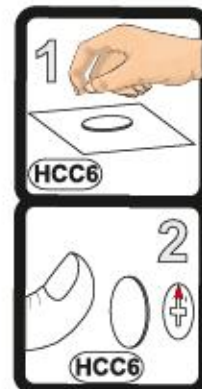
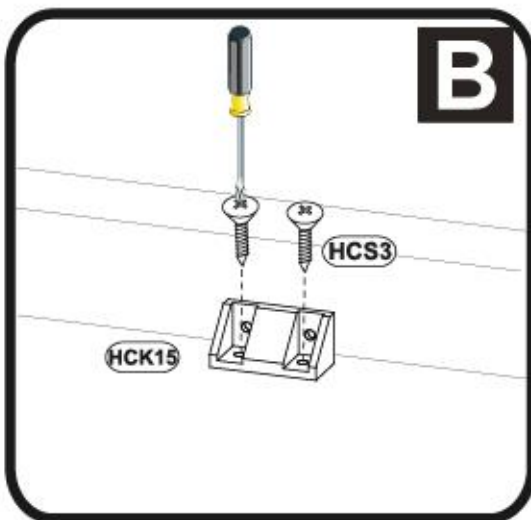
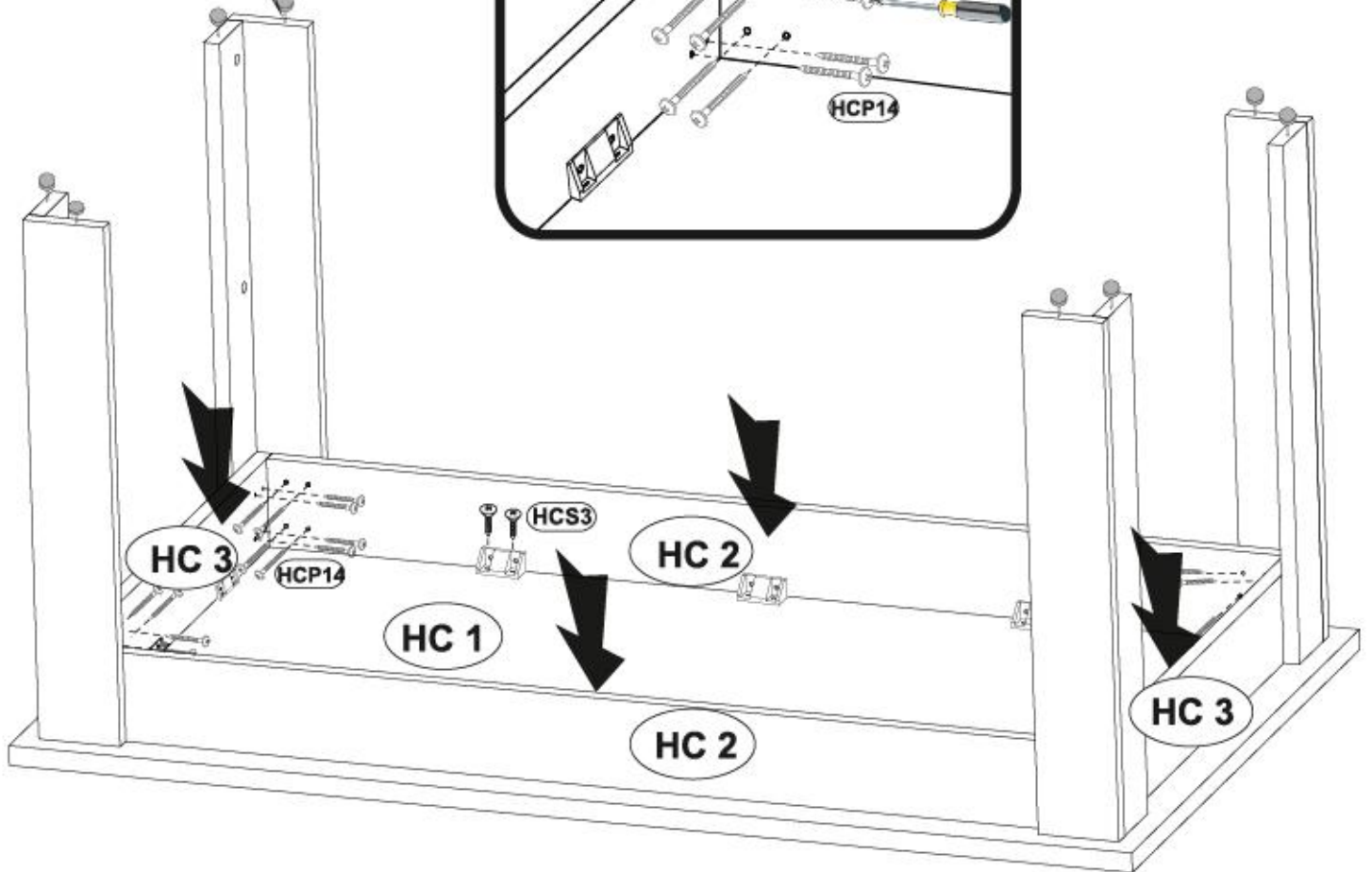
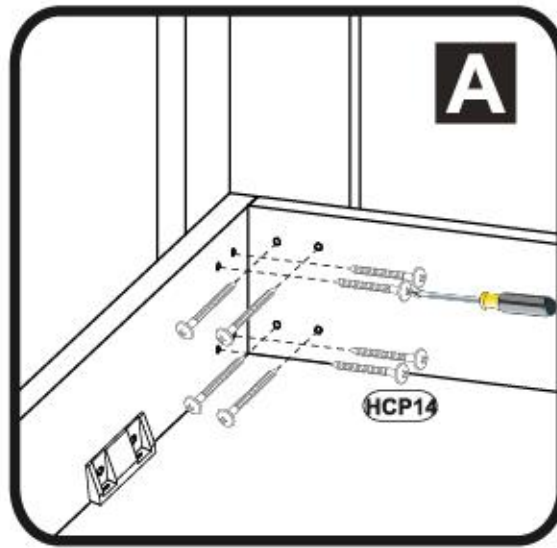



# RAVENNA 02

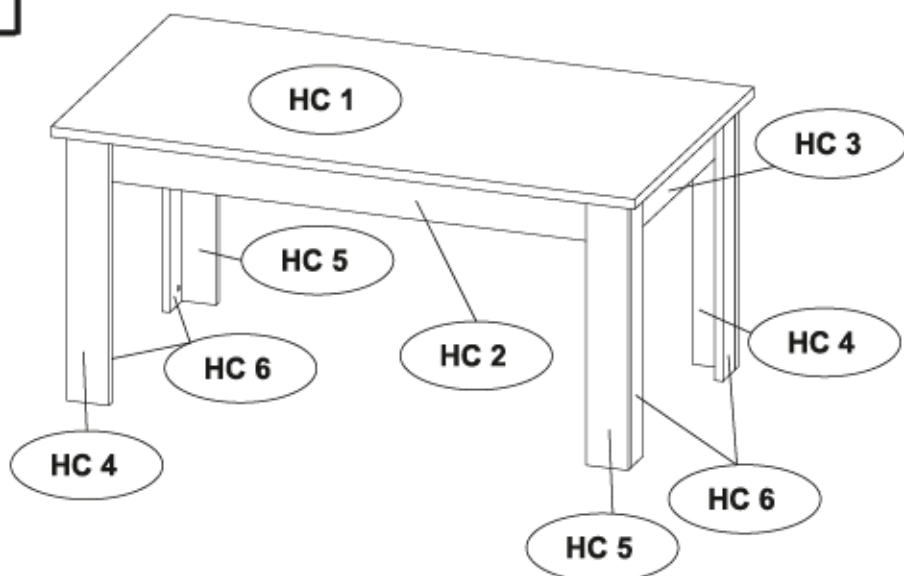

**D** Unser Direktservice für Beschädigte  
Sollte Ihnen ein Beschädigter fallen, können Sie diese Servicekarte direkt an die untenstehende Adresse mailen. Wir können allerdings nur Beschädigte auf diesem Wege verschicken. Sollten Sie eine andere Beauftragung an Ihrem Möbelstück haben, so wenden Sie sich bitte direkt an Ihr Möbelhaus.

**GB** Our direct order service for fitting  
If a fitting part is missing, you can e-mail this service card directly to the address below. However, we can only send fitting parts in this way. If you have any other cause for complaint concerning your item of furniture, please contact your furniture store directly.

**CZ** Naše přímé služby pro kování  
Chybí-li vám nějaký díl z kování, můžete tuto servisní kartu odeslat e-mailem přímo na níže uvedenou adresu. Touto cestou však můžeme zoslat jen díly kování. Pokud byste reklamovali jiný díl nábytku, obraťte se přímo na svého prodejce nábytku.

**F** Bien étudier la notice de montage  
Si vous manquez une ferrure, veuillez envoyer directement la présente carte service à l'adresse e-mail indiquée ci-dessous. Cependant, ceci nous permet uniquement d'envoyer des ferrures. Pour tout autre type de réclamation concernant votre meuble, veuillez contacter directement votre magasin d'ameublement.

**I** Il nostro servizio diretto per l'ordine della ferramenta  
Qualora Vi dovesse mancare un pezzo di fissaggio, allora Vi preghiamo di inviare questa carta di servizio immediatamente all'indirizzo sottostante. Possiamo inviare i pezzi di fissaggio solamente per mezzo di questo procedimento. Qualora doviate avere qualche altra reclamazione in merito al mobile, allora Vi preghiamo di rivolgervi direttamente al Vostro Negozio di mobili.

**BG** НАМАМА ДИРЕКТНИТЕ УСЛУГИ ЗА ОБЕДИ  
Ако липневат части от комплектта, потърсете насоката сервисна карта и я изпратете на e-mail адреса, посочен по-долу. По този начин можем да доставим само липващи елементи от обекта. Ако установите други дефекти на мебелта, Ви съветваме да се обвържете със мебелната експлоатация, от който сте закупили стоката.

**NL** Onze directservice voor losse onderdelen  
Wanneer er een onderdeel ontbreekt, kunt u deze servicekaart direct aan onderstaand e-mailadres sturen. Wij kunnen lings deze weg echter alleen losse onderdelen versturen. Mocht u een ander probleem aan uw meubel hebben, verzoekten wij u contact op te nemen met uw meubeldealer.

**PL** Nasz bezpośredni serwis części montażowych  
Jeżeli brakuje części koniecznych do montażu, prosimy o przesłanie nam niniejszej karty serwisowej na niżej podany adres e-mailowy. W ten sposób możemy przesyłać jedynie brakujące części. W przypadku innych reklamacji dotyczących mebla, prosimy zgłosić się do salonu meblowego, w którym został dokonany zakup.

**HR** Servis za okove  
U slučaju da nedostaje neki od dijelova molimo vas da na dole navedenu mail adresu pošaljete ovaj servisni obrazac. Na ovaj način mogu se dostaviti samo okovi. U slučaju da imate dodatne prigovore vezane uz komad namještaja molimo vas da se obratite izravno trgovini namještaja gdje je bili kupljen.

**HU** Direktszolgáltatunk vasalátok esetén  
Ha hiányzik egy vasalat, ezt a kártyát közvetlenül elküldheti az alább látható címre. Azonban csak a vasalatokat tudunk így küldeni. Amennyiben másfajta reklamációt áll fel birtoklásátjánál felénk, forduljon közvetlenül a boltjához.

**SK** Naše priama služba pre škádu kování  
Ak by Vám chýbala niekaja časť kování, môžete poslať túto servisnú kartu poslať e-mailom na nižšie uvedenú adresu. Dieľo kování vieme poslať iba týmto spôsobom. Ak by ste mali inú reklamáciu ohľadom Vášho nábytku, obráťte sa priamo na Vašu predajňu nábytku.

**SLO** Naše direktno uslužbo službe za okovje  
Če vam manjka kakšno okovje, lahko to servišno kartico pošljete po e-pošti direktno na spodnji naslov. Po tej poti vam lahko pošljemo samo okovje. Če želite reklamirati kakšen drug del pohištva, se obrnite neposredno na vašo trgovino pohištva.

**RO** Servisul direct pentru feronerie  
In cazul în care vă lipsește o piesă de feronerie puteți să trimiteți direct acest card de service prin e-mail la adresa de mai jos. Noi nu putem expedia piese de feronerie decât pe această cale. Dacă aveți o altă reclamație referitoare la piesa de mobilier, atunci vă rugăm să vă adresați direct la magazinul dvs. de mobilier.

**RUS** Наш прямой сервис для поставок фурнитуры  
Если окажется, что Вам не хватает того или иного элемента фурнитуры, Вы можете отправить сервисную карту по факсу непосредственно на нижеприведенный адрес электронной почты. Однако, таким образом мы можем отправить лишь фурнитуру. Если же у Вас возникнут иные претензии относительно приобретенной мебели, пожалуйста, обращайтесь непосредственно в организацию, осуществляющую продажу.

**S** Vår direktservice för beslagdelar  
Om du saknar en beslagdel kan du skicka detta servicekort direkt till o-postadressen som anges nedan. Tänk på att detta är den enda möjligheten att skicka beslagdelar till dig. Om du vill reklamera din möbel av annan anledning måste du kontakta ditt möbelförhandlare.

**ES** Nuestro servicio directo para accesorios  
Si le falta algún accesorio, puede enviar este tarjeta de servicio directamente a la siguiente dirección. No obstante, por este método solo podemos enviar accesorios. Si tiene alguna otra objeción sobre su mueble, consulte directamente con su mueblería.

**TR** Donatılar için doğrudan servisimiz  
Bir donatınız eksikse bu servis kartını doğrudan aşağıda bulunan adrese doğrudan mail yollayabilirsiniz. Sadece bu yolla donatılar gönderiliriz. Mobilyanızda başka şikayetleriniz varsa lütfen doğrudan mobilya satıcınıza danışın.

HC 1	x1	1596	896	28	1/1
HC 2	x2	1446	124	22	1/1
HC 3	x2	783	124	22	1/1
HC 4	x2	729	115	22	1/1
HC 5	x2	729	115	22	1/1
HC 6	x4	729	93	22	1/1

# RAVENNA 02

**D** Unser Direktservice für Beschädigte  
 Sollte Ihnen ein Beschädigtes fehlen, können Sie diese Servicekarte direkt an die untenstehende Adresse mailen. Wir können allerdings nur Beschädigte auf diesem Wege ersetzen. Sollten Sie eine andere Bausituation an Ihrem Möbelstück haben, so wenden Sie sich bitte direkt an Ihr Möbelhaus.

**GB** Our direct order service for fitting  
 If a fitting part is missing, you can e-mail this service card directly to the address below. However, we can only send fitting parts in this way. If you have any other cause for complaint concerning your item of furniture, please contact your furniture store directly.

**CZ** Naše přímé služby pro kování  
 Chybí-li vám nějaký díl z kování, můžete tuto službu kartou odvést e-mailem přímo na níže uvedenou adresu. Touto cestou však můžeme nahradit jen díly kování. Pokud byste reklamovali jiný díl nábytku, obraťte se přímo na svého prodejce nábytku.

**F** Bien servir: la notice de montage  
 Si vous manquez une ferrure, veuillez envoyer directement la présente carte service à l'adresse e-mail indiquée ci-dessous. Cependant, ceci nous permet uniquement d'envoyer des ferrures. Pour tout autre type de réclamation concernant votre meuble, veuillez contacter directement votre magasin d'ameublement.

**I** Il nostro servizio diretto per il cambio della ferramenta  
 Qualora Vi dovesse mancare un pezzo di fissaggio, allora Vi preghiamo di inviare questa carta di servizio immediatamente all'indirizzo sottoelencato. Possiamo inviare i pezzi di fissaggio solamente per mezzo di questo procedimento. Qualora dovete avere qualche altra reclamazione in merito al mobile, allora Vi preghiamo di rivolgerVi direttamente al Vostro Negozio di mobili.

**BG** Извадена директна услуга за обкова  
 Ако липсваат части от коващата, допълнително изпратете сервисна карта и ни я изпратете на e-mail адреса, посочен по-долу. По този начин можем да доставим само липсващи елементи от обкова. Ако установите други дефекти по мебелите, Ви съветваме да се обвържете със мебелната къща/магазин, от който сте закупили стоката.

**NL** Onze directservice voor leen ontbrekende  
 Wanneer er een onderdeel ontbreekt, kunt u deze servicekaart direct aan onze afdeling e-mailadres sturen. Wij kunnen leen deze weg echter alleen beschadigen vasturen. Mocht u een ander probleem aan uw meubel hebben, verzoeken wij u contact op te nemen met uw meubeldealer.

**PL** Nasz bezpośredni serwis części montażowych  
 Jeżeli brakuje części koniecznych do montażu, prosimy o przesłanie nam niniejszej karty serwisowej na niżej podany adres e-mailowy. W ten sposób możemy przesłać Państwu tylko brakujące części. W przypadku innych reklamacji dotyczących mebla, prosimy zgłosić się do salonu meblowego, w którym został dokonany zakup.

**HR** Servis za okove  
 U slučaju da nedostaje neki od dijelova molimo vas da na dole navedenu mail adresu pošaljete ovaj servisirni obrazac. Na ovaj način mogu se dostaviti samo okovi. U slučaju da imate dodatne prigovore vezane uz komad namještaja molimo vas da se obratite izravno trgovini namještaja gdje je isti kupljen.

**HU** Direktszolgálatunk vasalataik esetén  
 Ha hiányzik egy vasalat, ezt a kártyát közvetlenül elküldheti az alább található címre. Azonban csak a vasalataikat tudunk így küldeni. Amennyiben másfajta reklamáció áll fenn bifordambájt illetően, forduljon közvetlenül a boltiáruházra.

**SK** Naše přímé servis pro škáň kovania  
 Ak by Vám chýbala nejaká časť kování, môžete poslať túto servisnú kartu poslať e-mailom na nižšie uvedenú adresu. Týmto kováňu vieme poslať iba týmto spôsobom. Ak by ste mali inú reklamáciu ohľadom Vášho nábytku, obráťte sa priamo na Vašu predajňu nábytku.

**SLO** Naše direktno uslužbo storitve za okovje  
 Če vam manjka kakšno okovje, lahko to servisirno kartico pošljete po e-pošti direktno na spodnji naslov. Po tej poti vam lahko pošljemo samo okovje. Če želite reklamirati kakšen drug del pohištva, se obrnite neposredno na vašo trgovino pohištva.

**RO** Serviciu-ul nostru direct pentru feronerie  
 In cazul in care va lipseste o piesa de feronerie puteti sa trimiti un direct acest card de service prin e-mail la adresa de mai jos. Noi nu putem expedia piese de feronerie decit pe aceasta cale. Dacã aveti o altã reclamație referitoare la piesa de mobilier, atunci va rugãm sã vã adresați direct la magazinul div. de mobilã.

**RUS** Наш прямой сервис для поставки фурнитуры  
 Если окажется, что Вам не хватает той или иного элемента фурнитуры, Вы можете отправить сервисную карту по факсу непосредственно на нижеприведенный адрес электронной почты. Однако, таким образом мы можем переслать лишь фурнитуру. Если же у Вас возникнет иное претензия относительно приобретенной мебели, пожалуйста, обращайтесь непосредственно в организацию, осуществляющую продажу.

**S** Vñ direktbenice fñr beskadigela:  
 Om du saknar en beskadigdel kan du skicka detta servicekort direkt till e-postadressen som anges nedan. Tank på att detta är den enda möjligheten att skicka beskadigdelar till dig. Om du vill reklamera din möbel av en annan anledning rådd du kontakta ditt möbelhus direkt.

**ES** Nuestro servicio directo para accesorios  
 Si le falta algún accesorio, puede enviar esta tarjeta de servicio directamente a la siguiente dirección. No obstante, por este método solo podemos enviar accesorios. Si tiene alguna otra objeción sobre su mueble, consulte directamente con su mueblería.

**TR** Donatılar için doğrudan servisimiz  
 Bir donatınız eksikse bu servis kartını doğrudan aşağıda bulunan adrese doğrudan mail yazabilirsiniz. Sadece bu yolla donatıları gönderebiliriz. Mobilyanızda başka şikayetiniz varsa lütfen doğrudan mobilya satıcınıza danışın.

**HCB1**  1018  
 8x28 X...

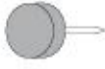
**HCF36**  1305  
 X...

**HCM1**  123894  
 X...

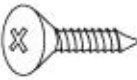
**HCS3**  1011  
 3,5x13 X...

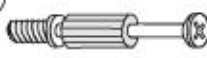
**HCT1**  11809  
 X...

**HCP14**  1059  
 4x35 X...

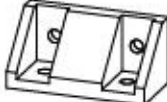
**HCK15**  81556  
 X...

**HCC6**  140318  
 φ20 X...

**HCK2**  1311  
 7x70 X...

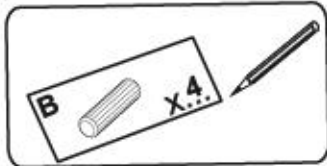

# RAVENNA 27

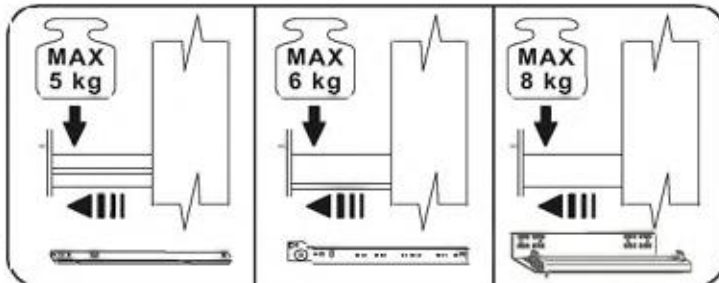
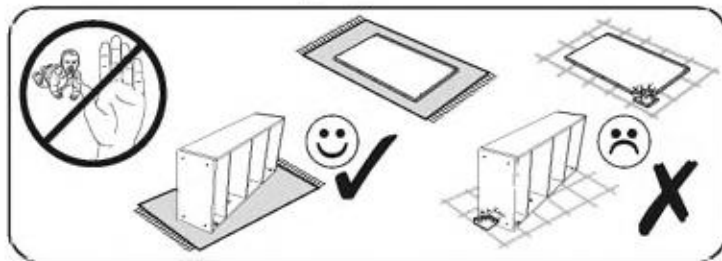
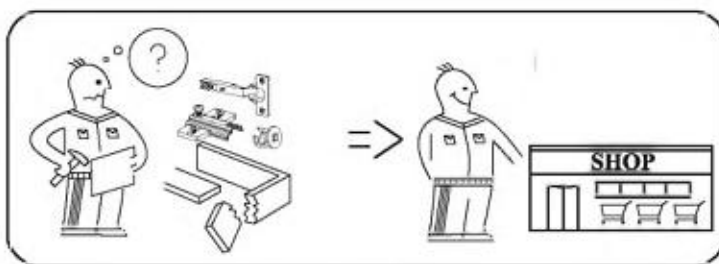
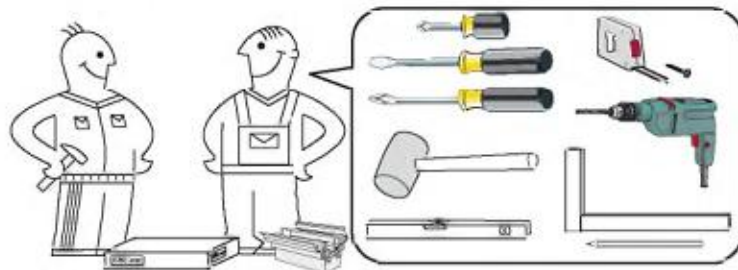
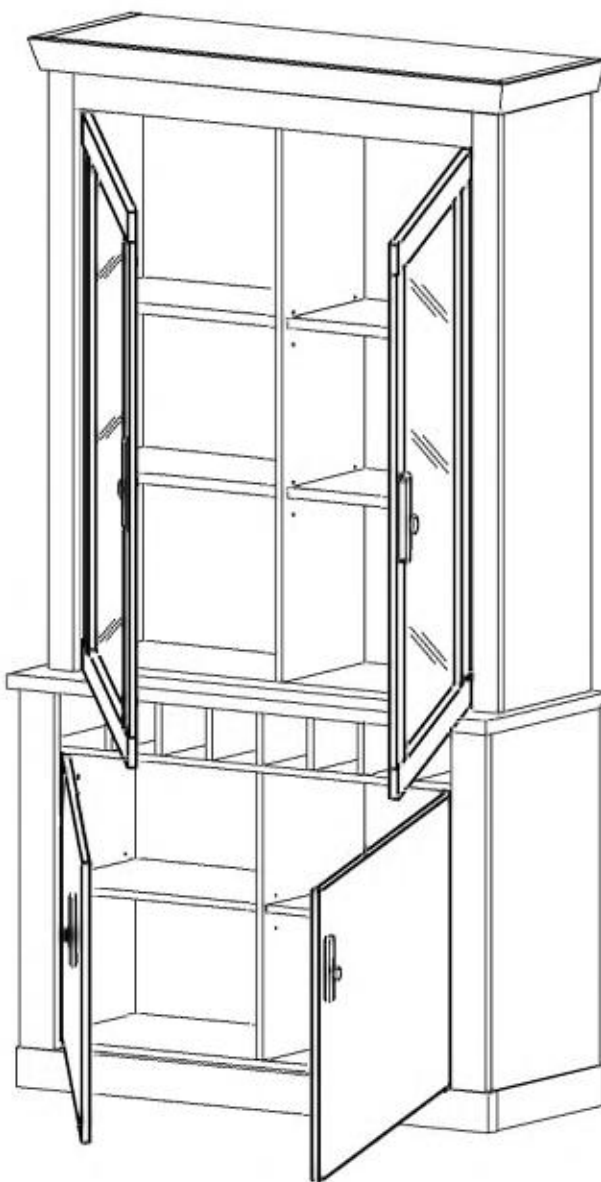
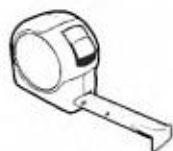
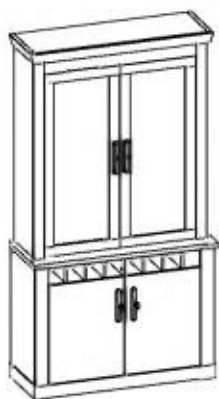

# RAVENNA 27

max.



5kg

HC 158

max.



40kg

HC 151

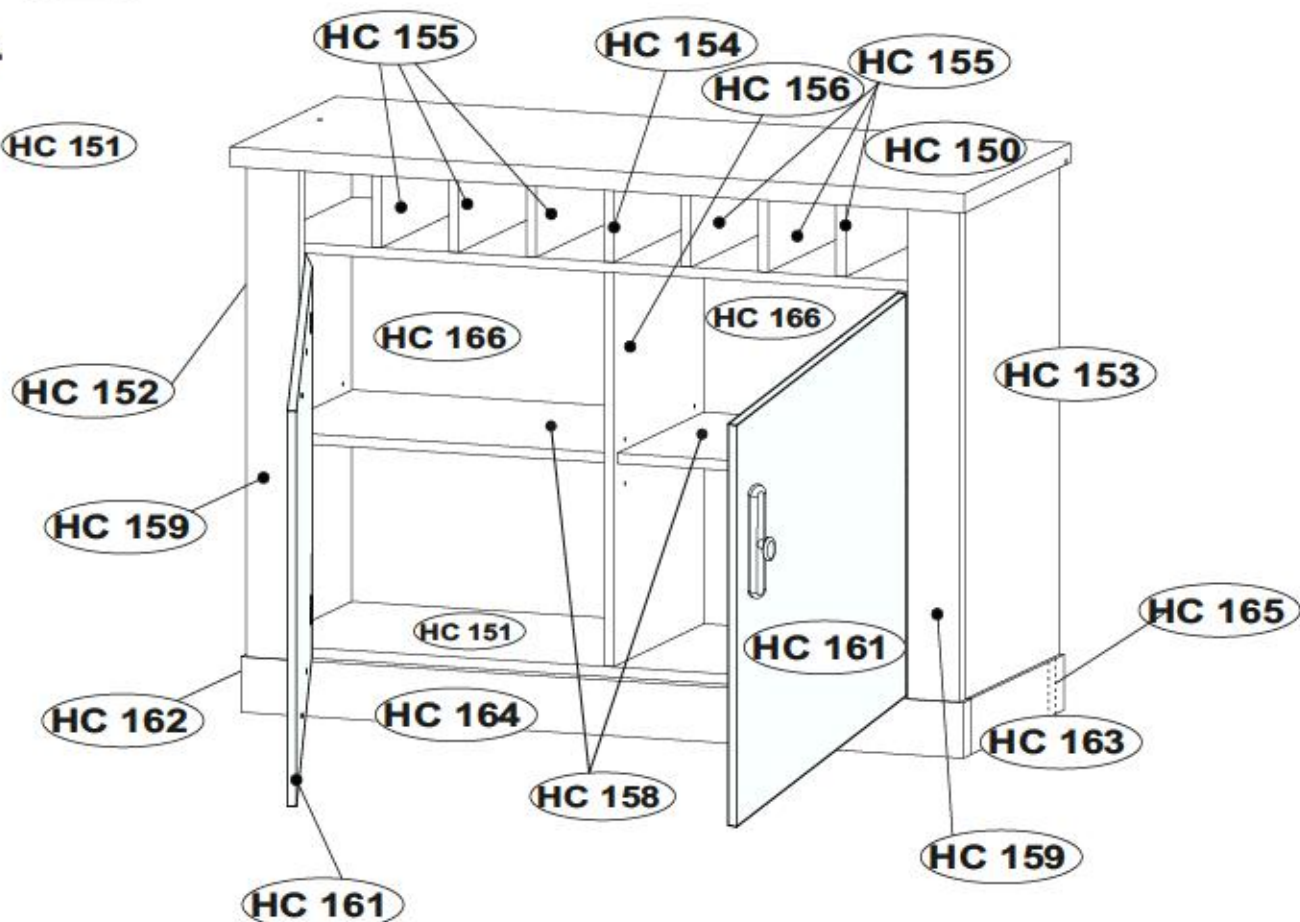

HC 150	x1	1111	440	28	2/3
HC 151	x1	1049	375	15	3/3
HC 152	x1	711	395	15	1/3
HC 153	x1	711	395	15	1/3
HC 154	x1	112	373	15	2/3
HC 155	x6	112	373	15	2/3
HC 156	x1	569	373	15	3/3
HC 157	x1	1049	374	15	3/3
HC 158	x2	516	360	15	3/3
HC 159	x2	711	80	22	1/3
HC 161	X2	593	456	15	2/3
HC 162	x1	392	80	28	2/3

HC 163	x1	392	80	28	2/3
HC 164	X1	1094	80	28	1/3
HC 165	x1	1036	80	28	2/3
HC 166	x2	716	530	2.5	1/3



# RAVENNA 27

max.



HC 174

max.



HC 170

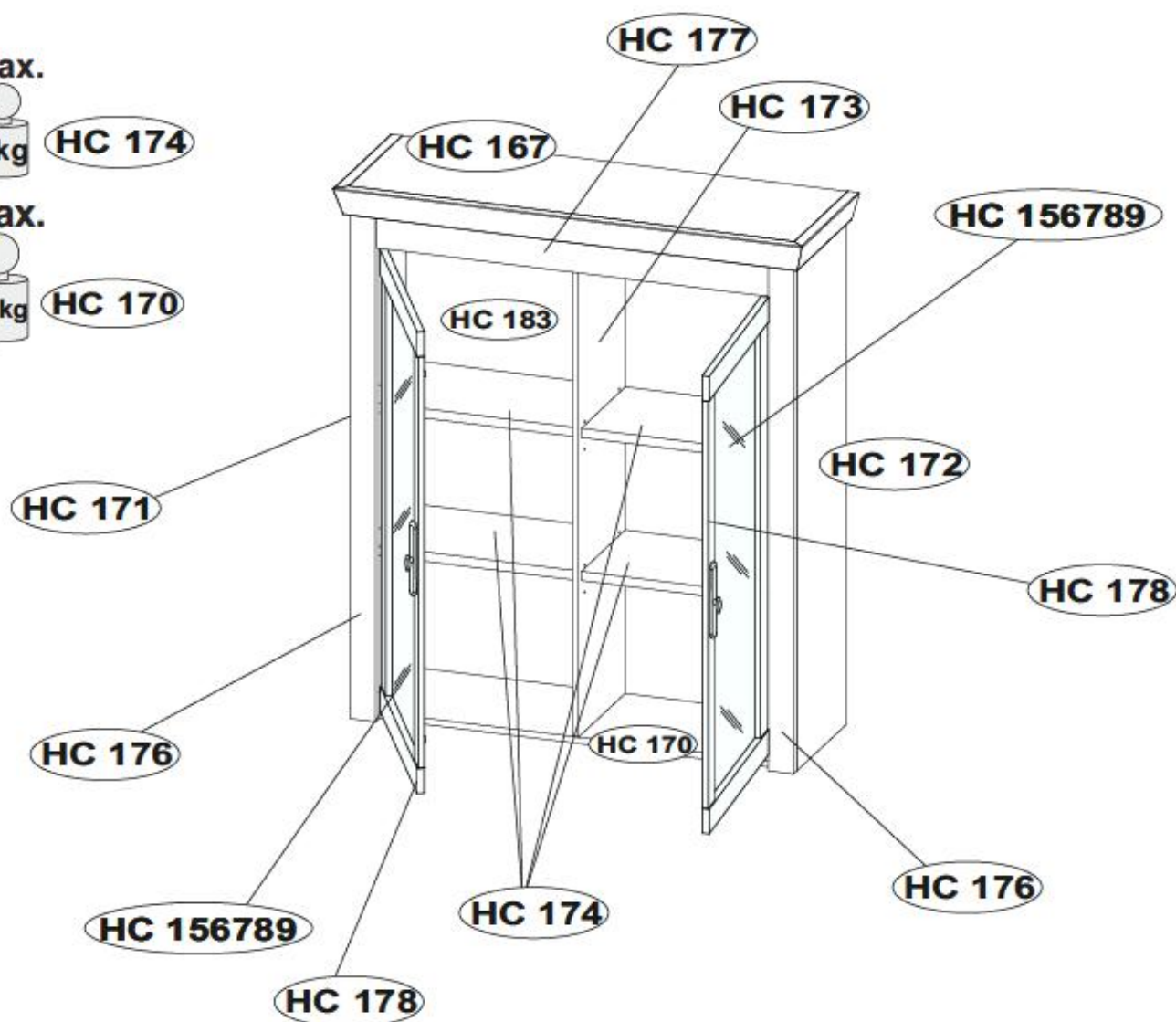



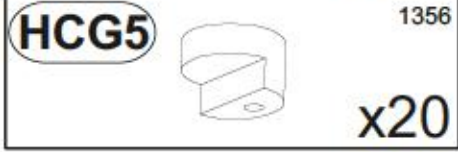
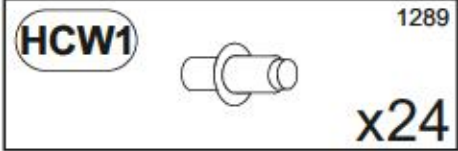
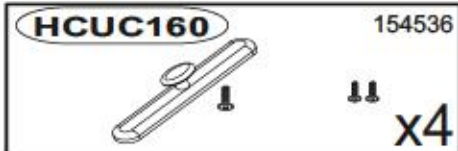
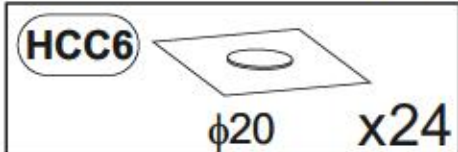
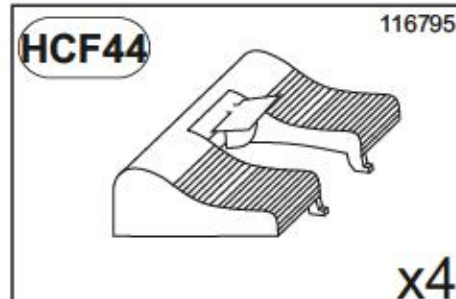
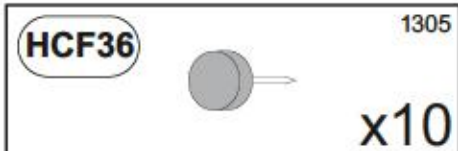
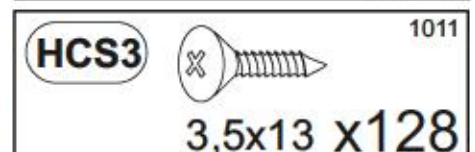
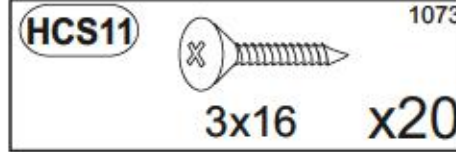
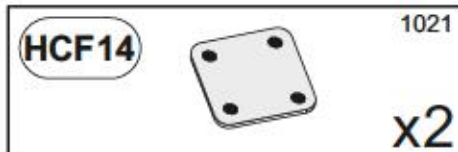
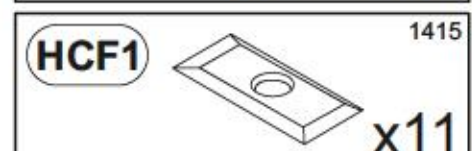
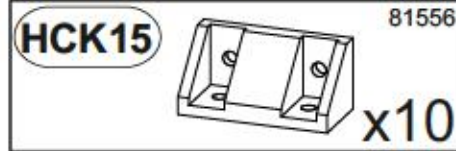
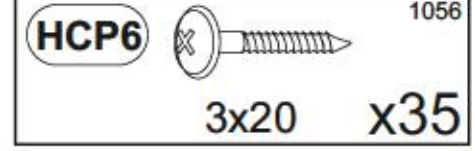
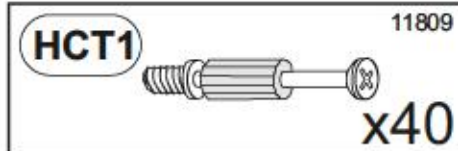
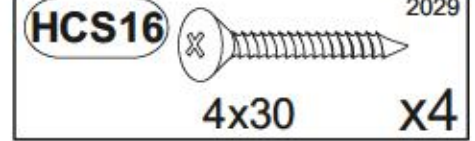
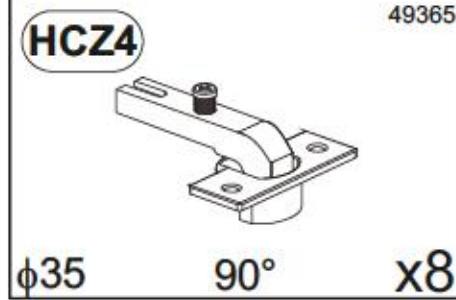
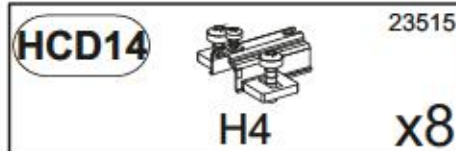
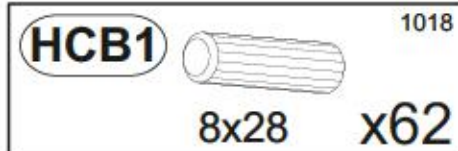

HC 167	x1	1102	371	65	1/3
HC 170	x1	1011	300	15	1/3
HC 171	x1	1236	320	15	3/3
HC 172	x1	1236	320	15	3/3
HC 173	x1	1221	300	15	3/3
HC 174	x4	497	273	22	1/3
HC 176	x2	1236	60	22	1/3
HC 177	x1	921	124	18	2/3
HC 178	x2	1106	456	18	2/3
HC 183	x2	1240	511	2.5	1/3
HC 156789	x2	1016	366	4	2/3

# RAVENNA 27





1

HCM1		123894	x4
HCT1		11809	x8
HCS3		1011	x8
HCK15		81556	x4
HCB1		1018	x4

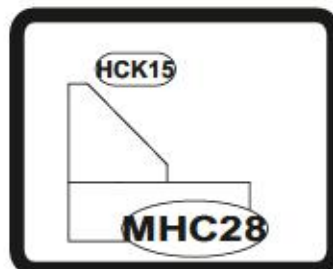
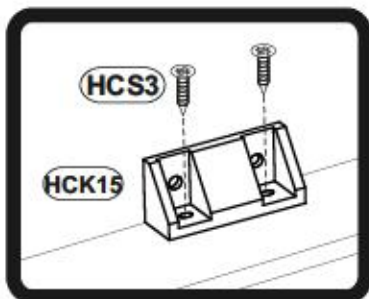
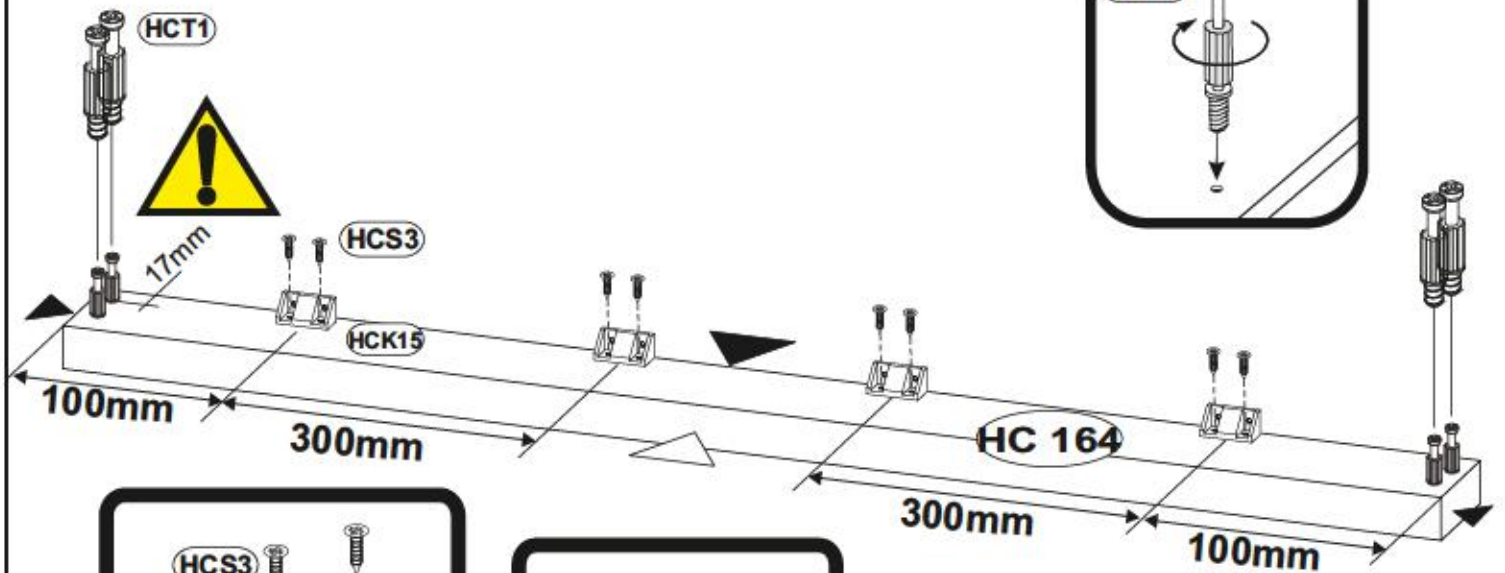
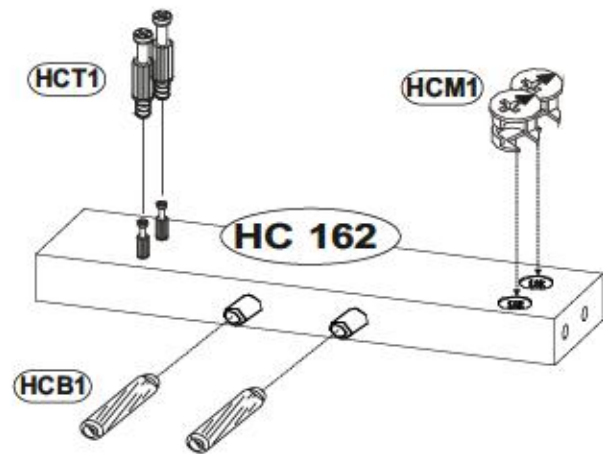
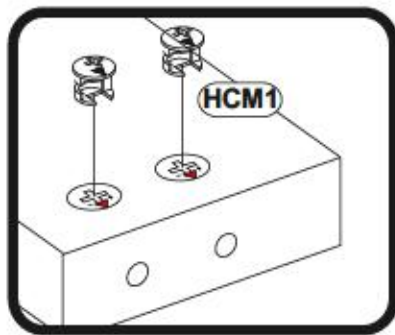
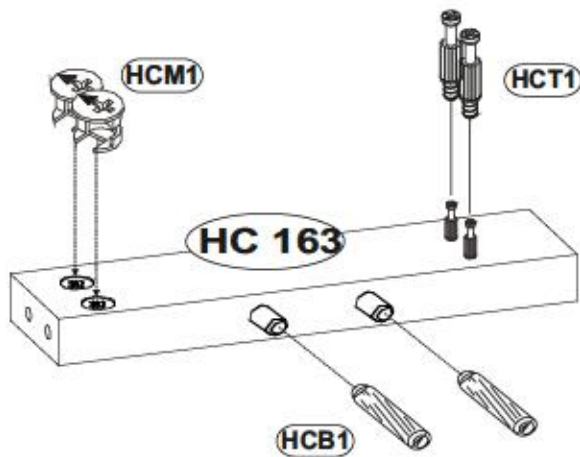

2

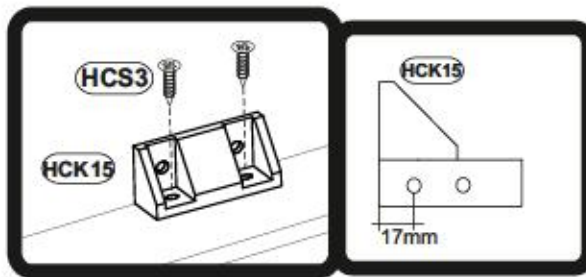

HCM1		123894	x4
HCS3		1011	x8
HCK15		81558	x4

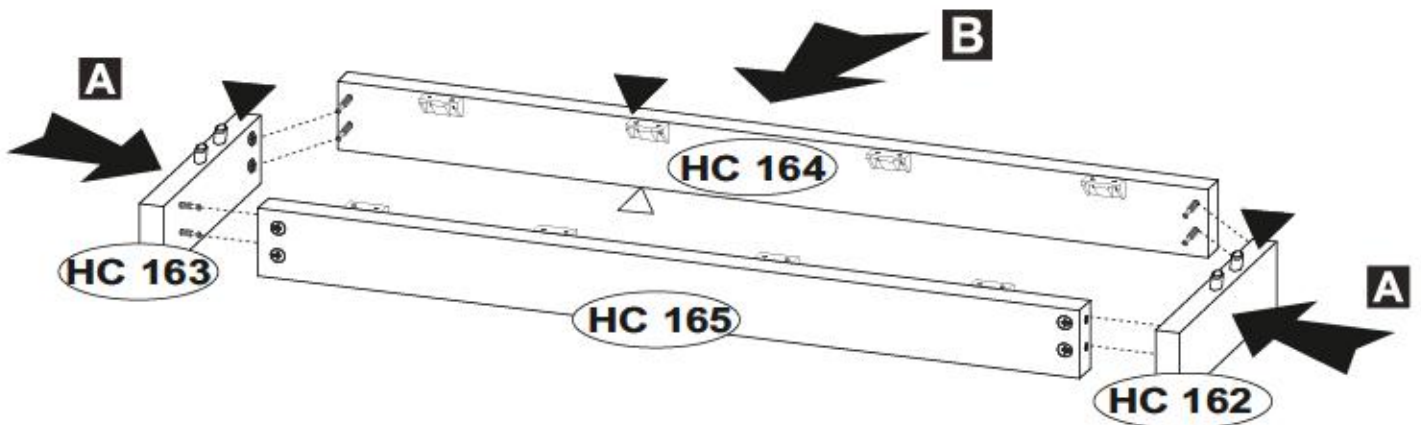
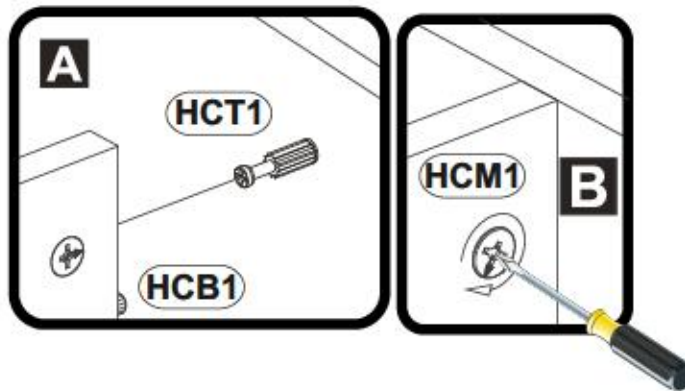
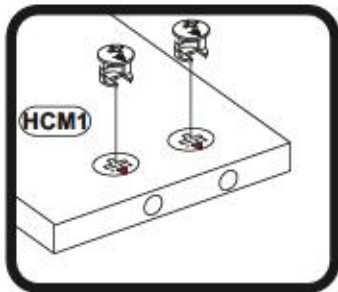
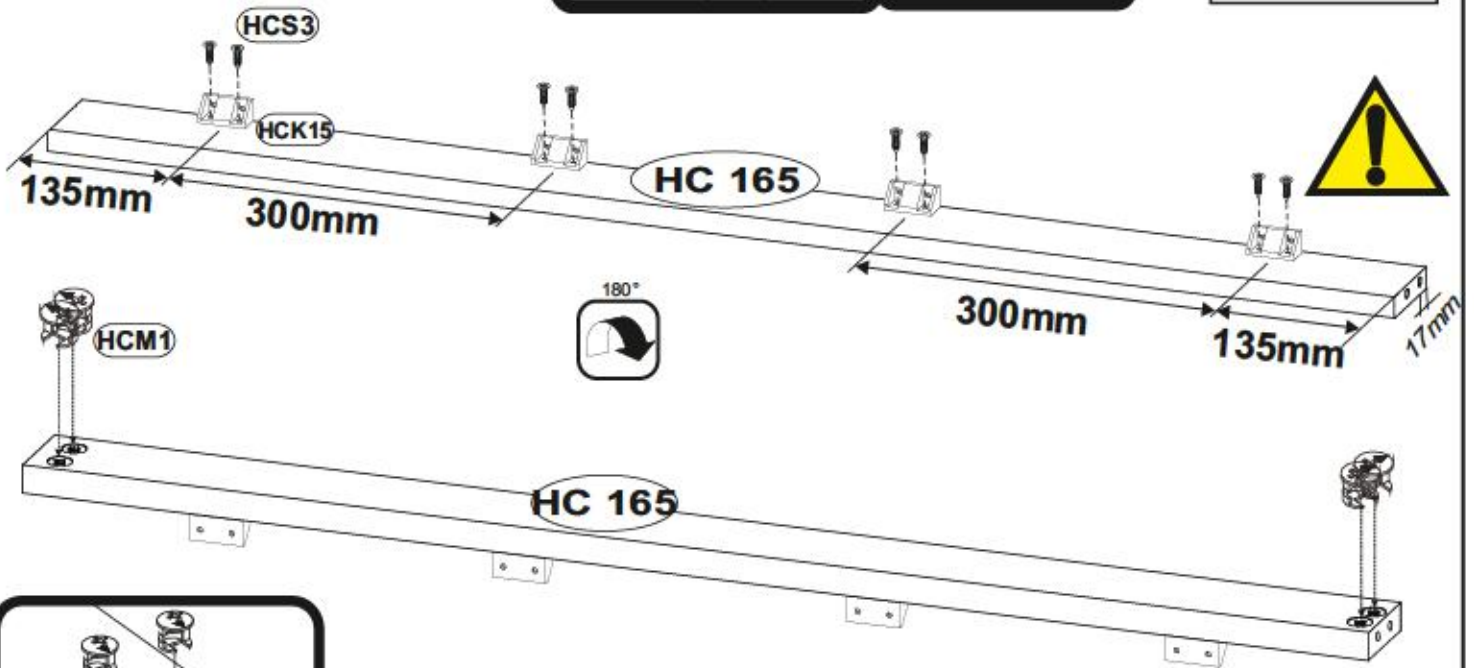

3

HCF36 1305  
x10

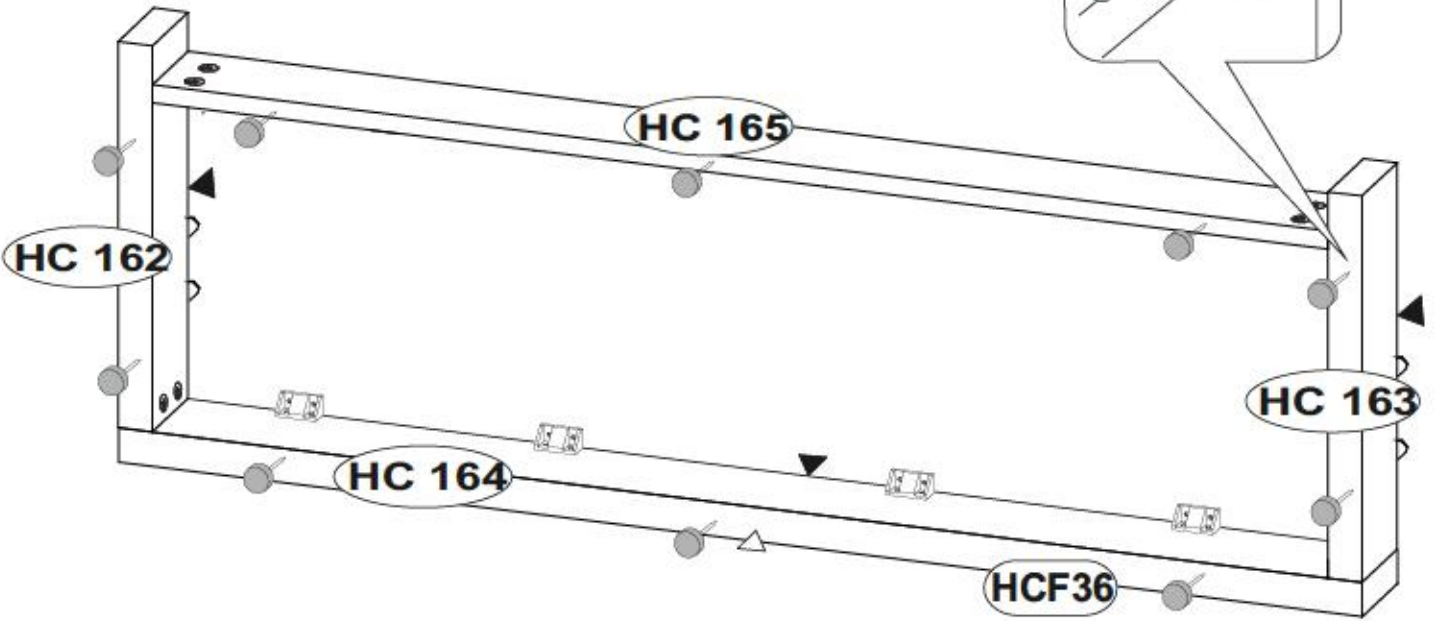
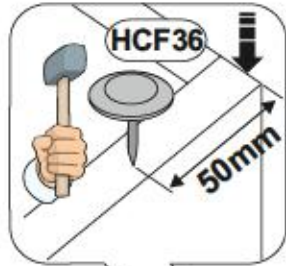

4



HCD14 H4 29.515  
x4

HCK13 407 16  
x8

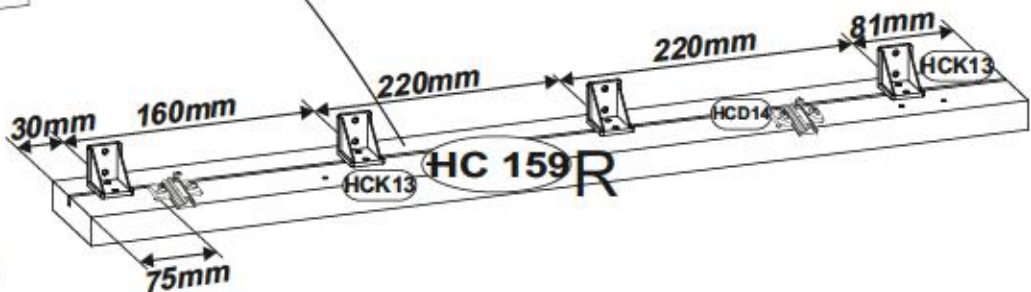
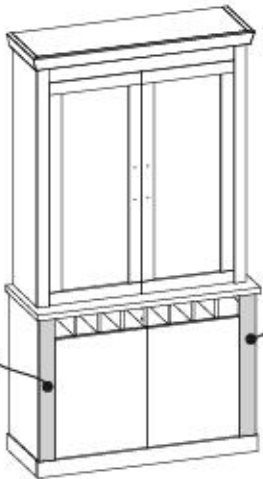
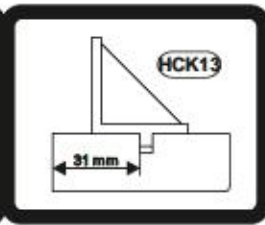
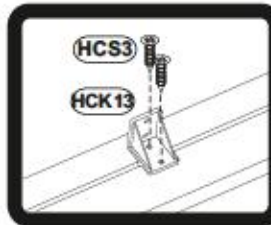
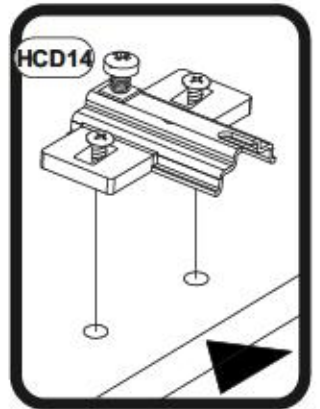
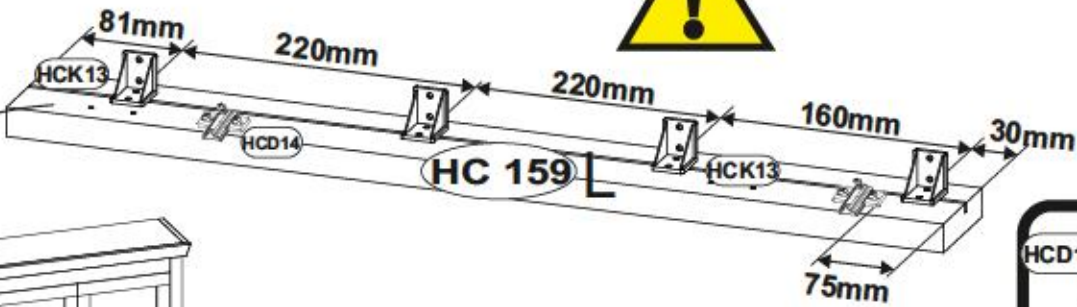
HCS3 1011  
3,5x13 x16



5

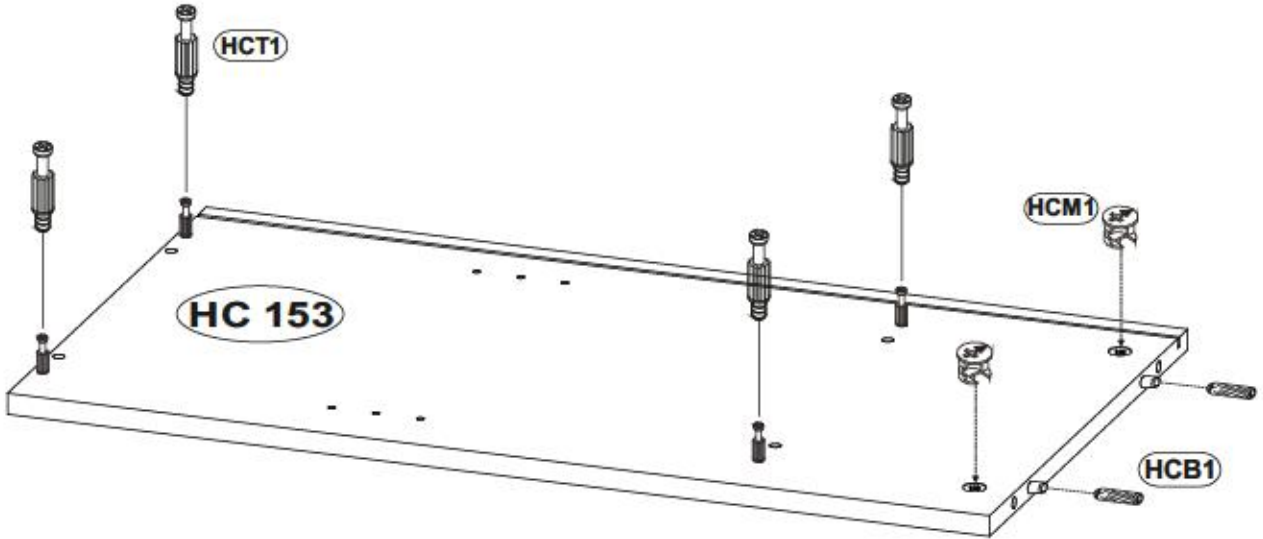
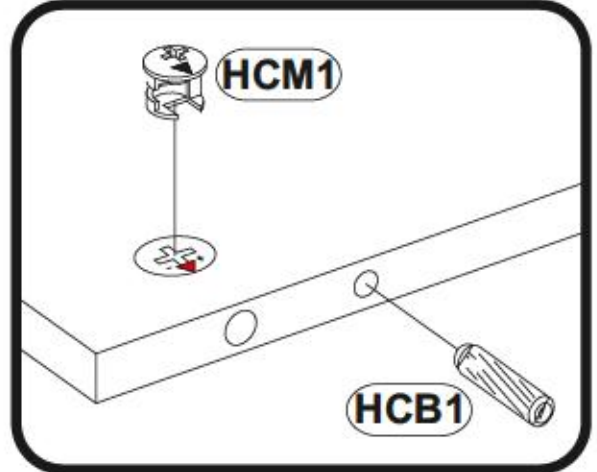
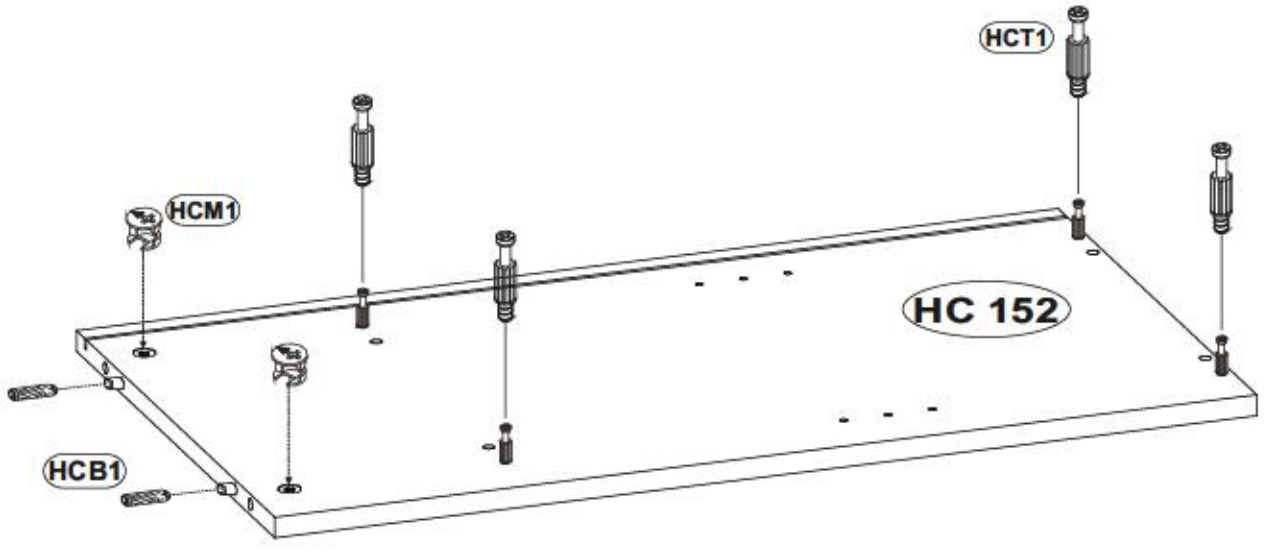

(HCB1)		1018
	8x28	x4
(HCM1)		12994
		x4
(HCT1)		11809
		x8



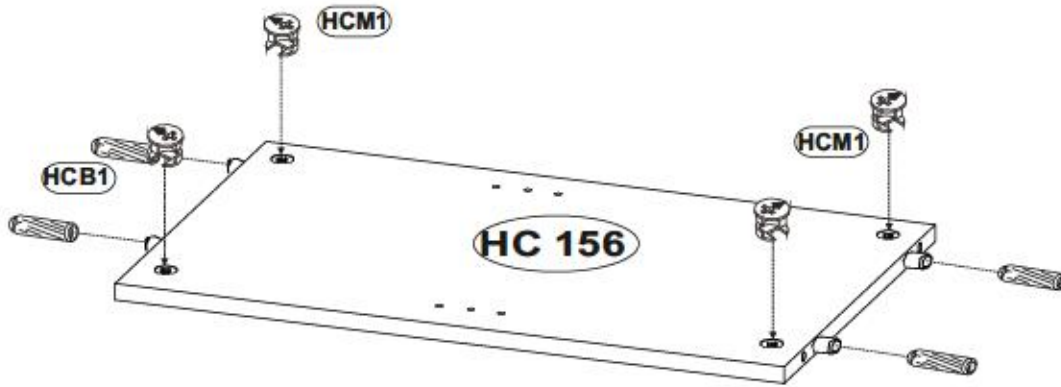

6



HCM1		123894
		x4
HCB1		1018
		x4

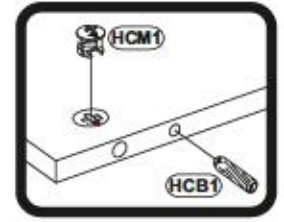

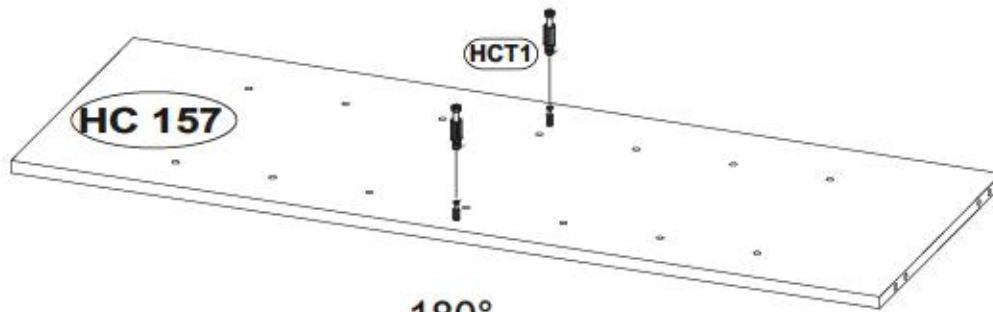

7



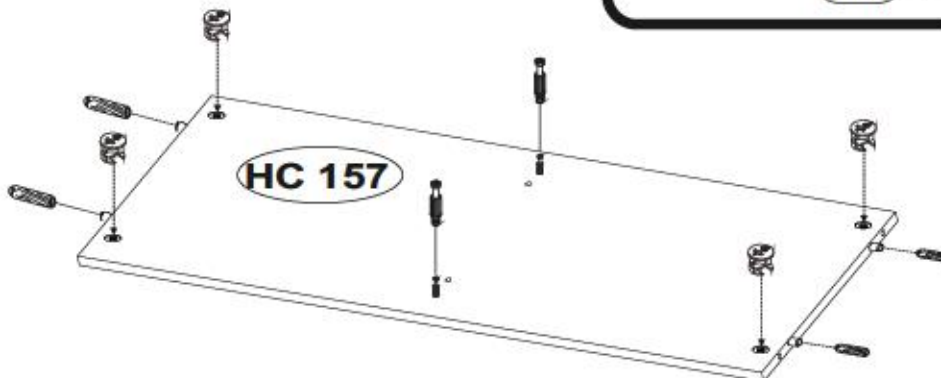
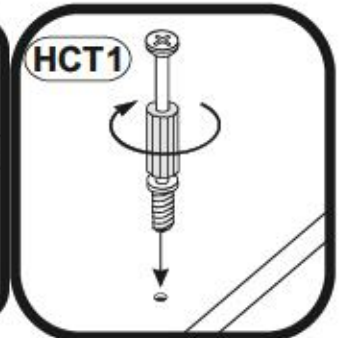
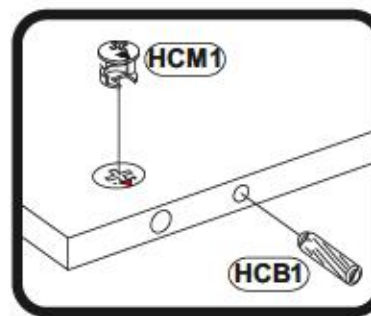

180°



HCM1		123894
		x4
HCT1		11809
		x4
HCB1		1018
		x4

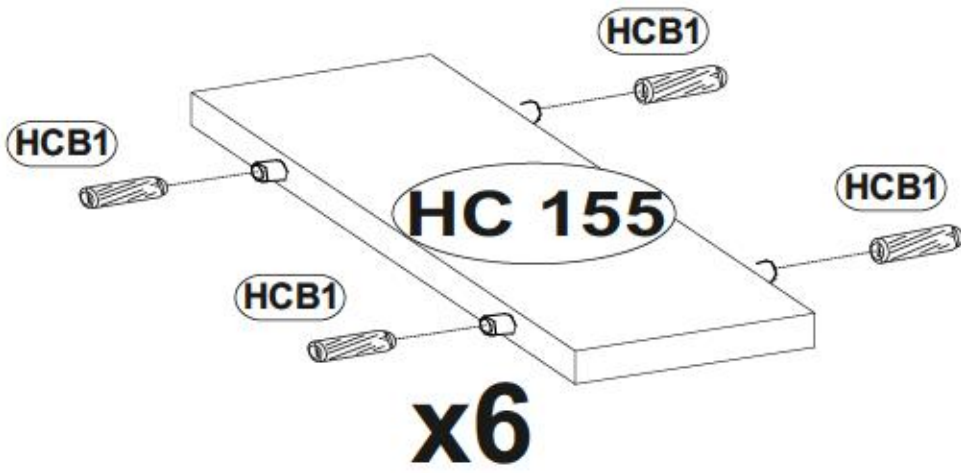
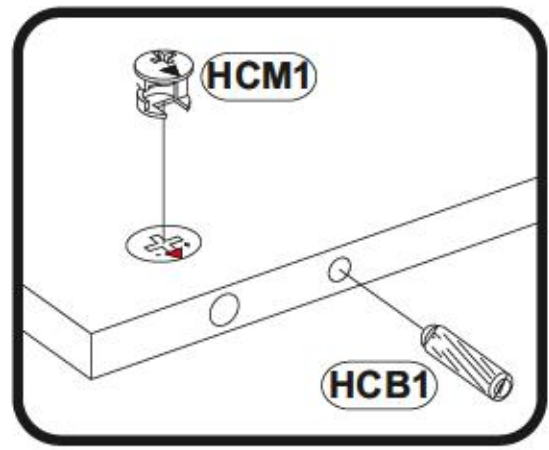
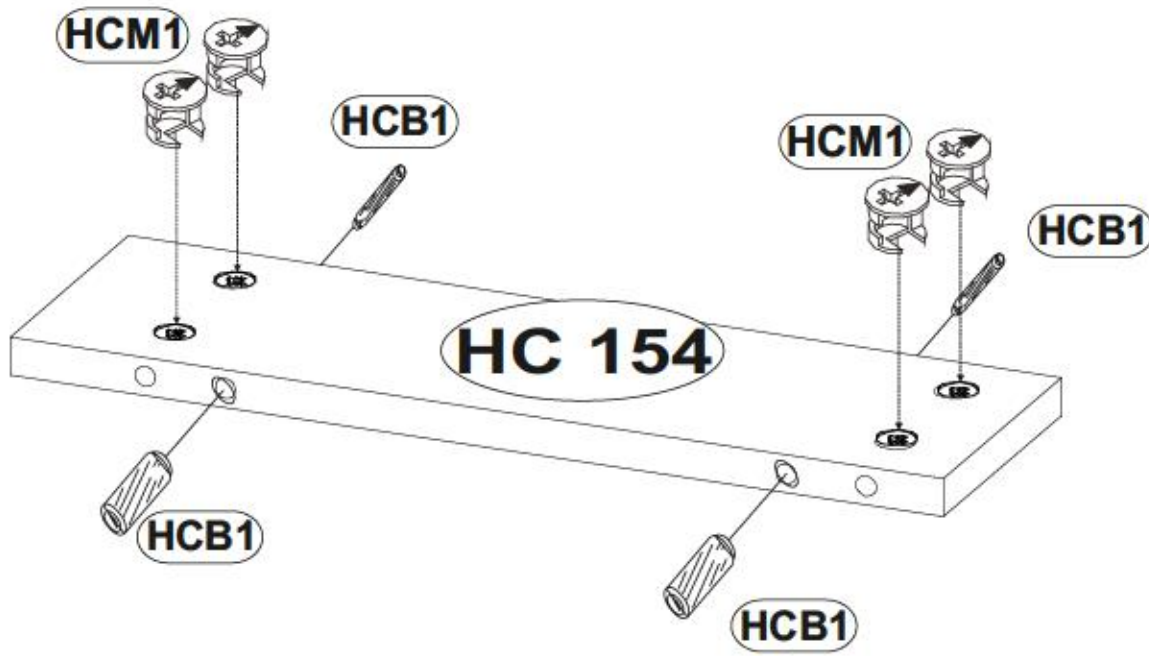

8

HCB1		10 18
	8x28	x28
HCM1		12 38 94
		x4





9

HCM1		123894
		x4
HCT1		15809
		x8
HCB1		1018
	8x28	x4

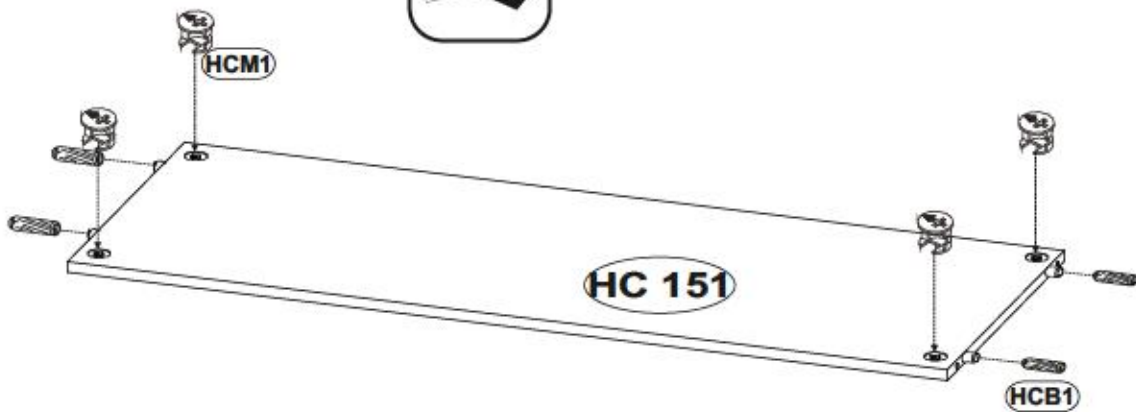
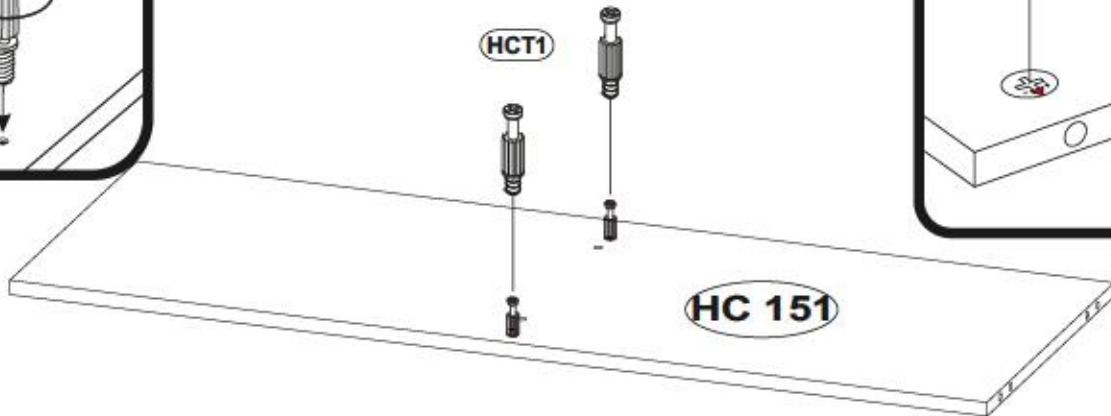
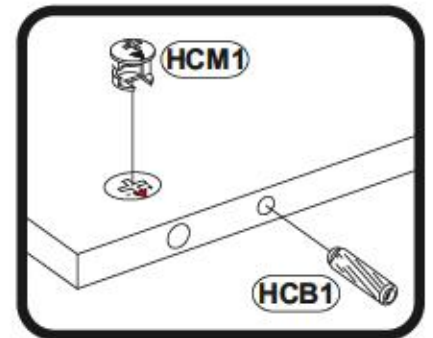
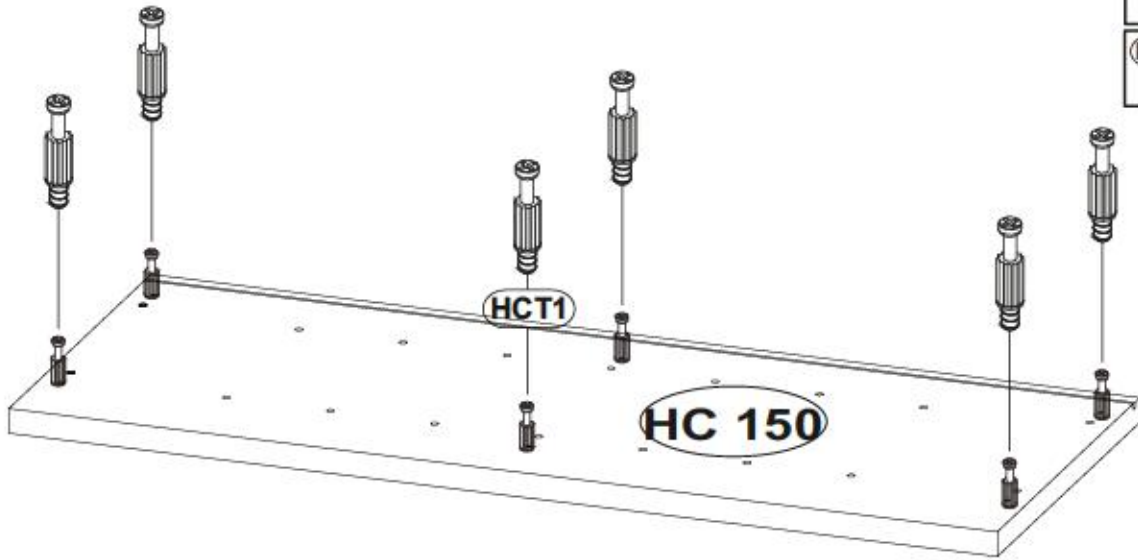

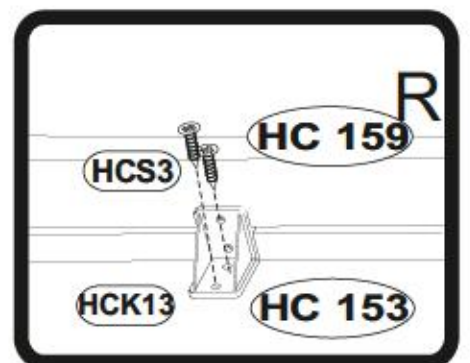
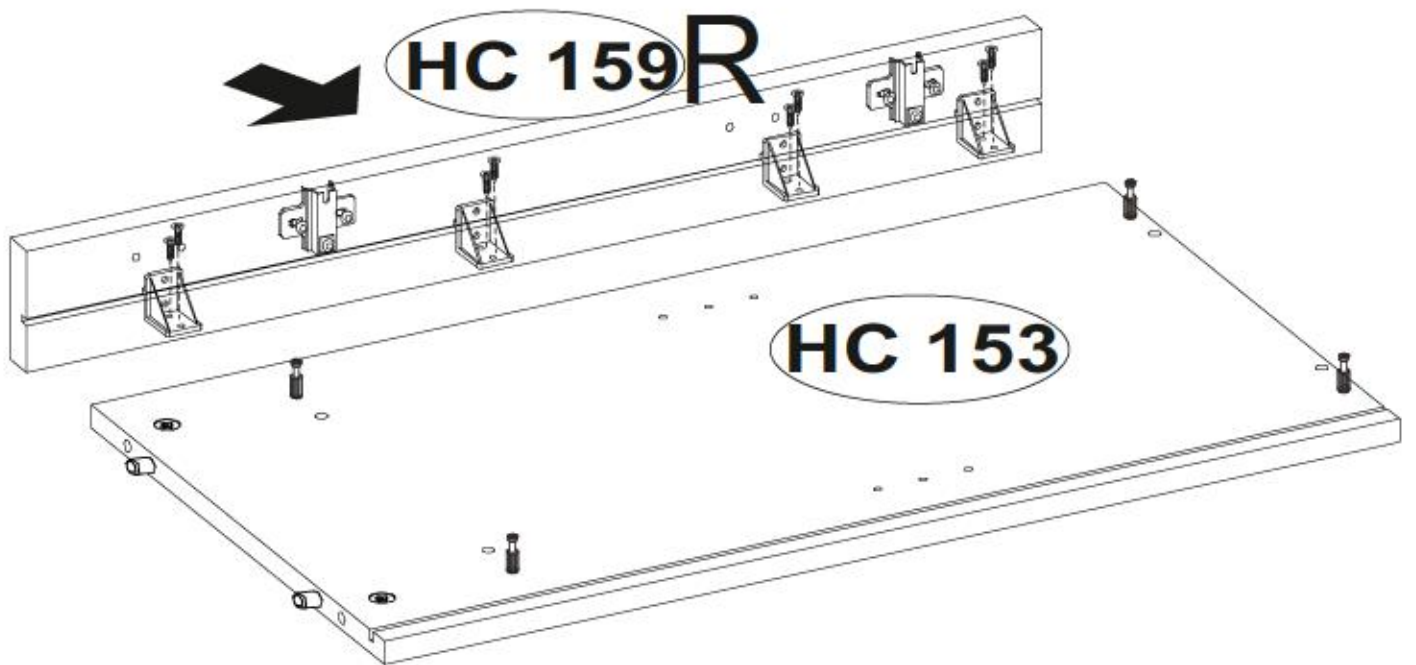
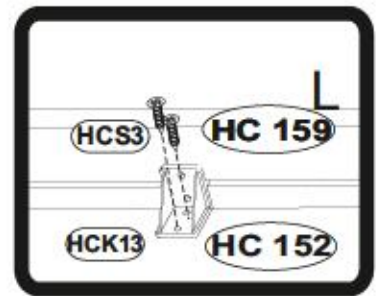
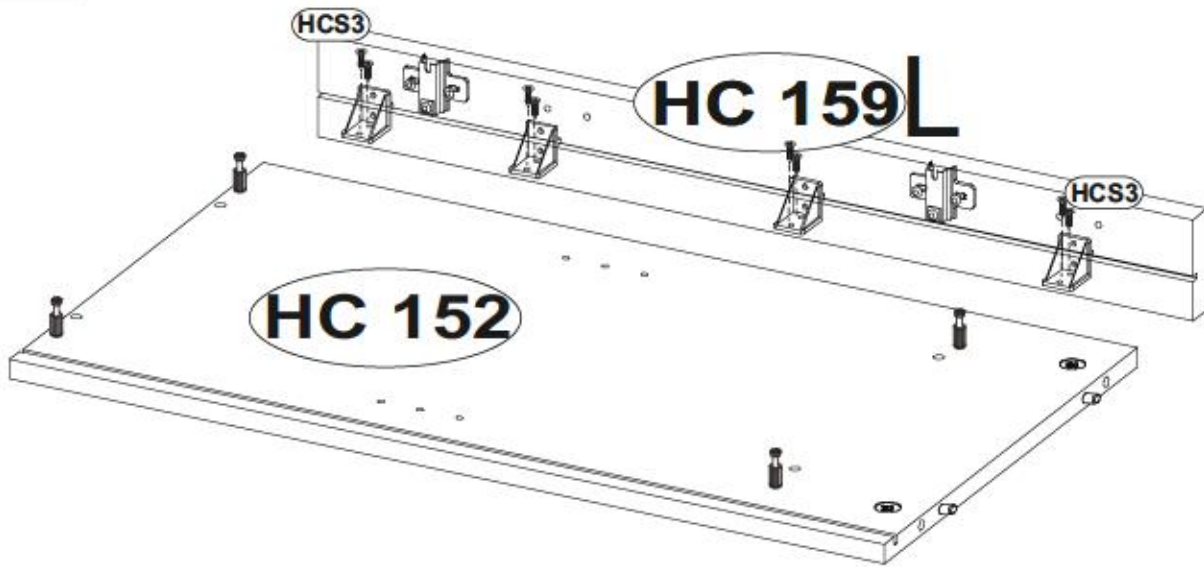

11

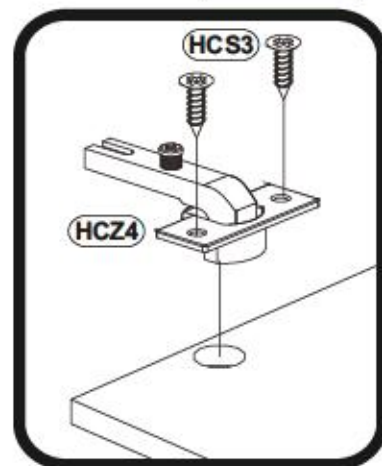
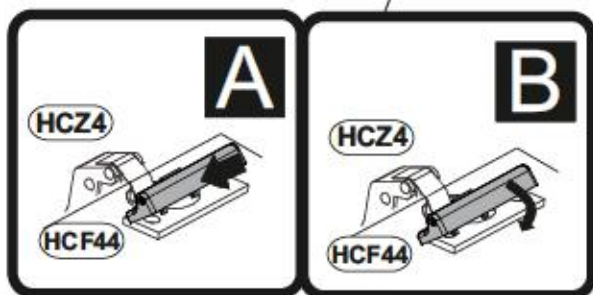
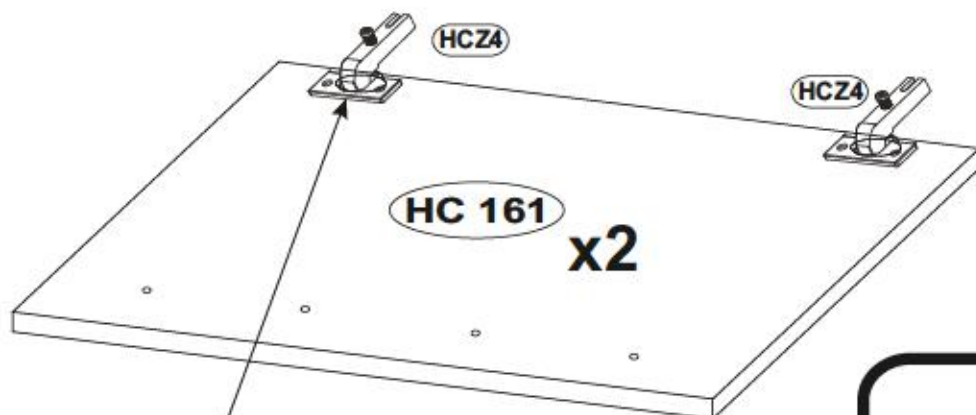
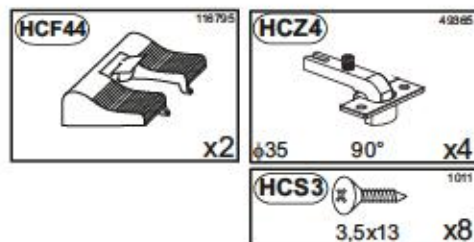

12

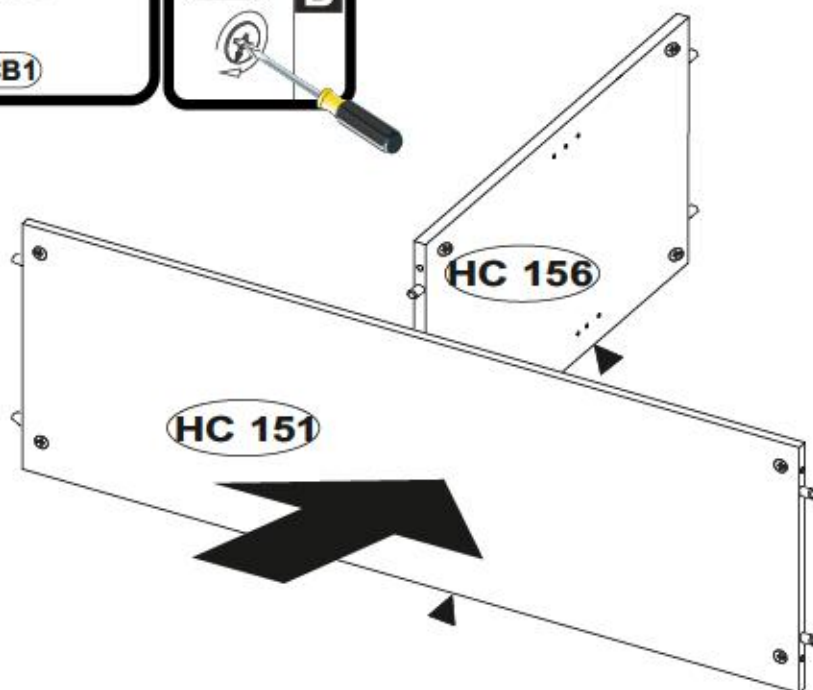
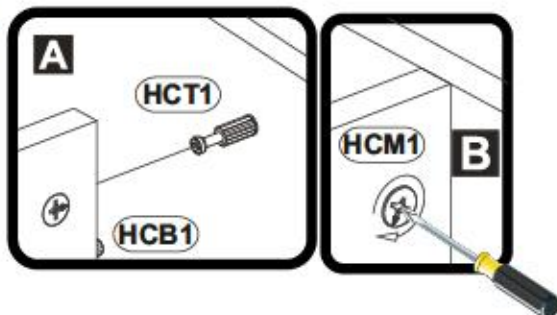

13

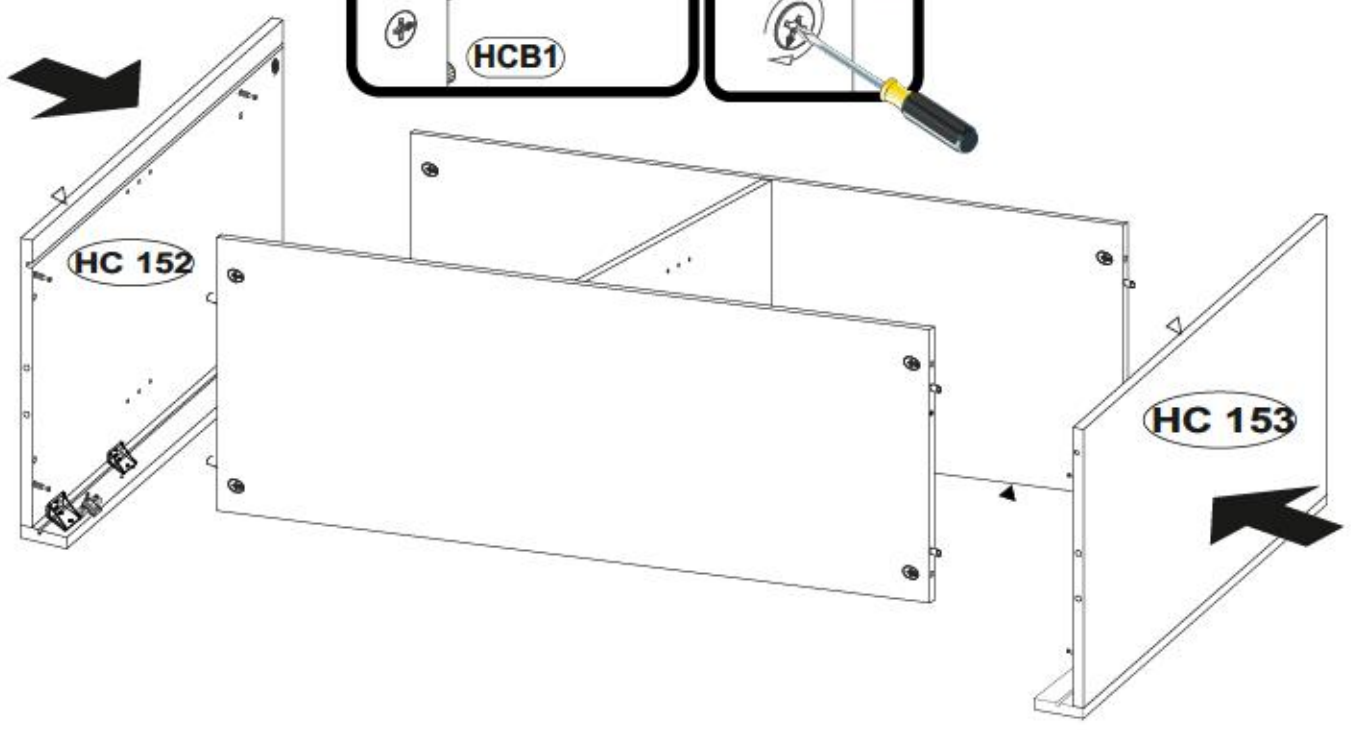
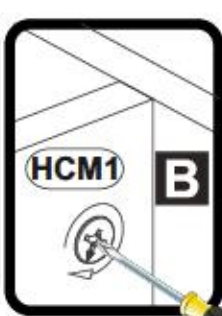
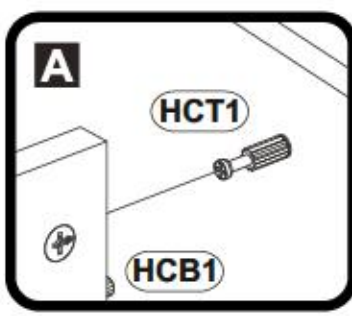
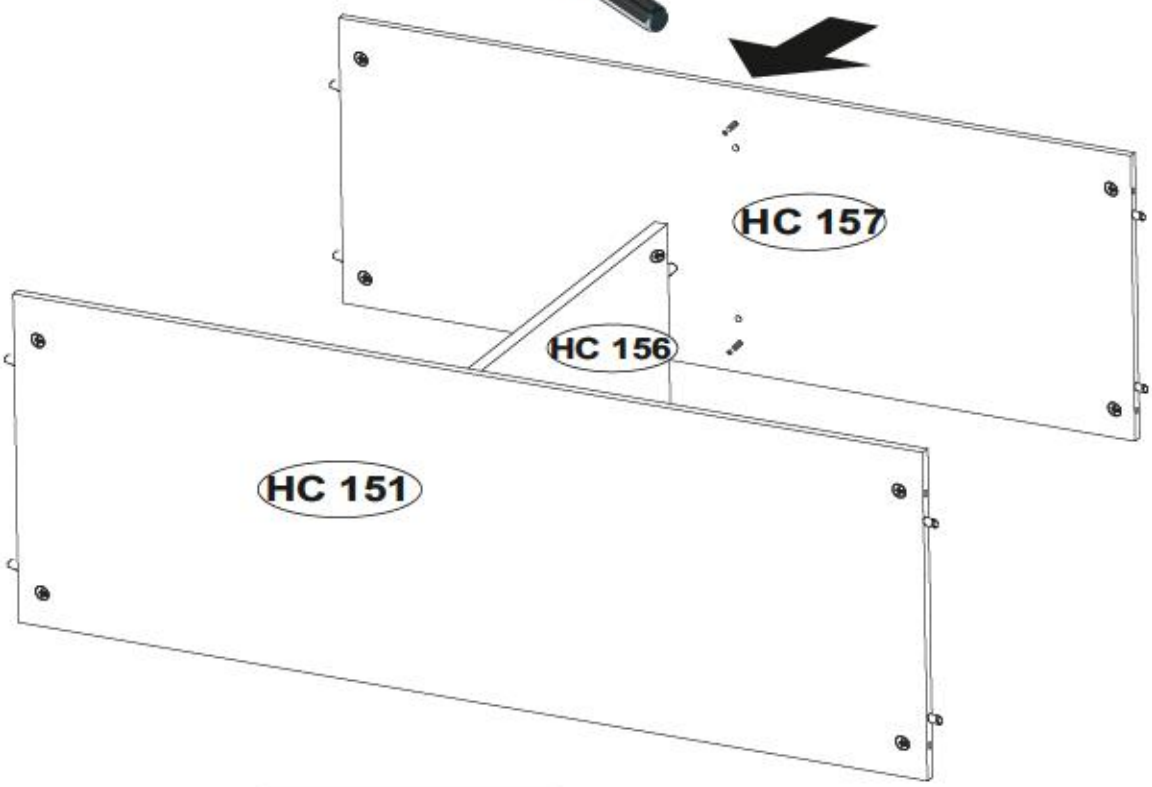
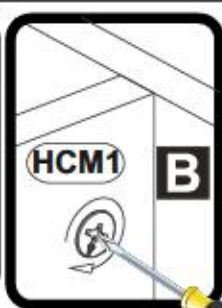
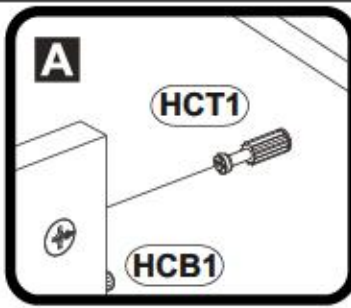

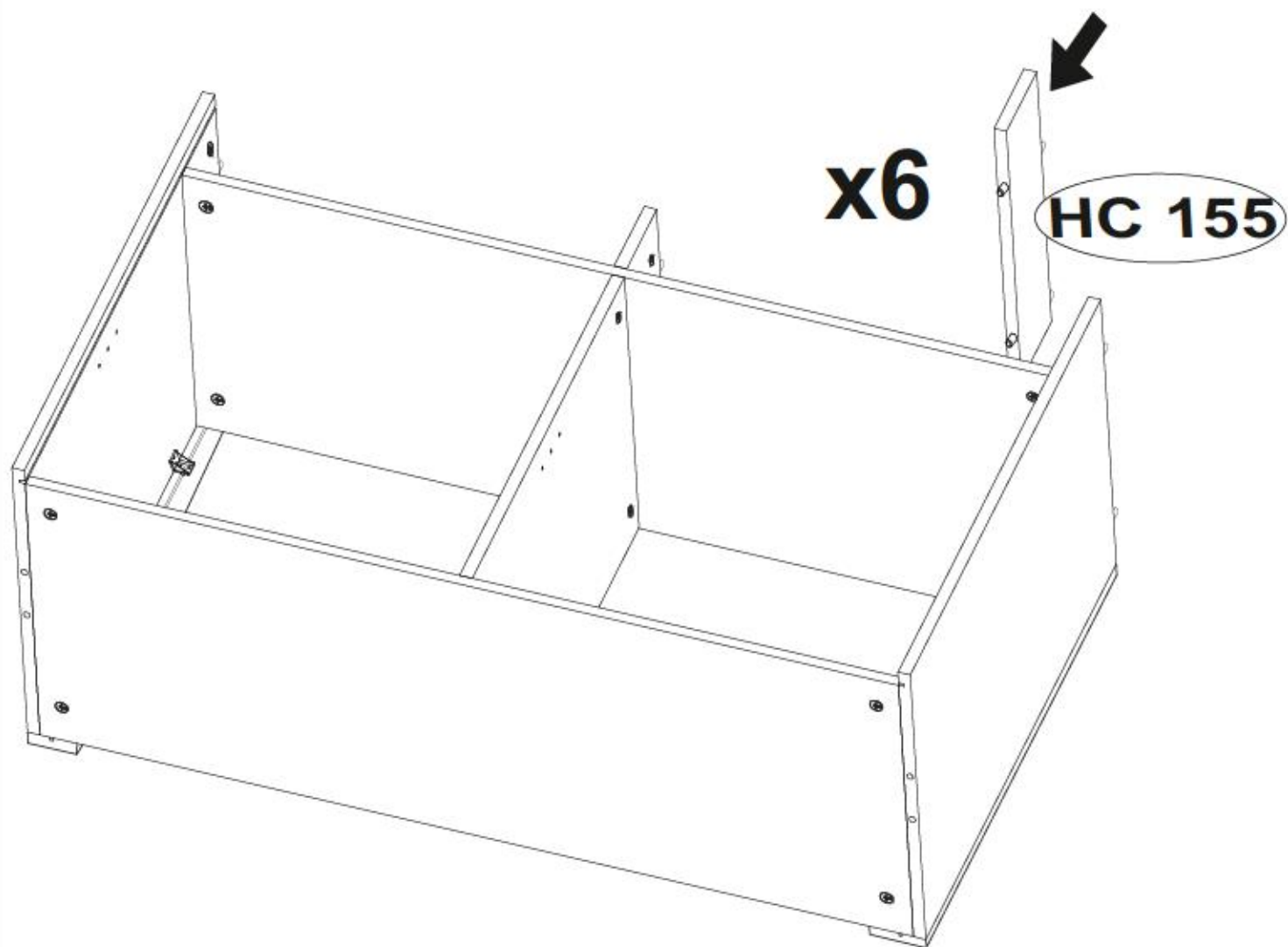
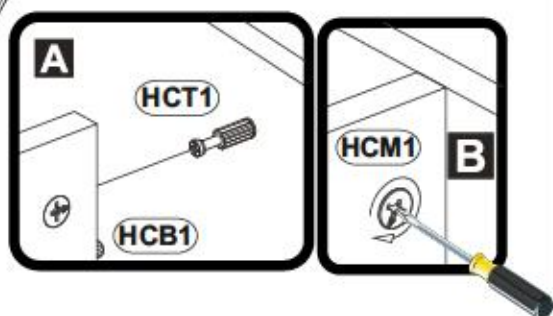
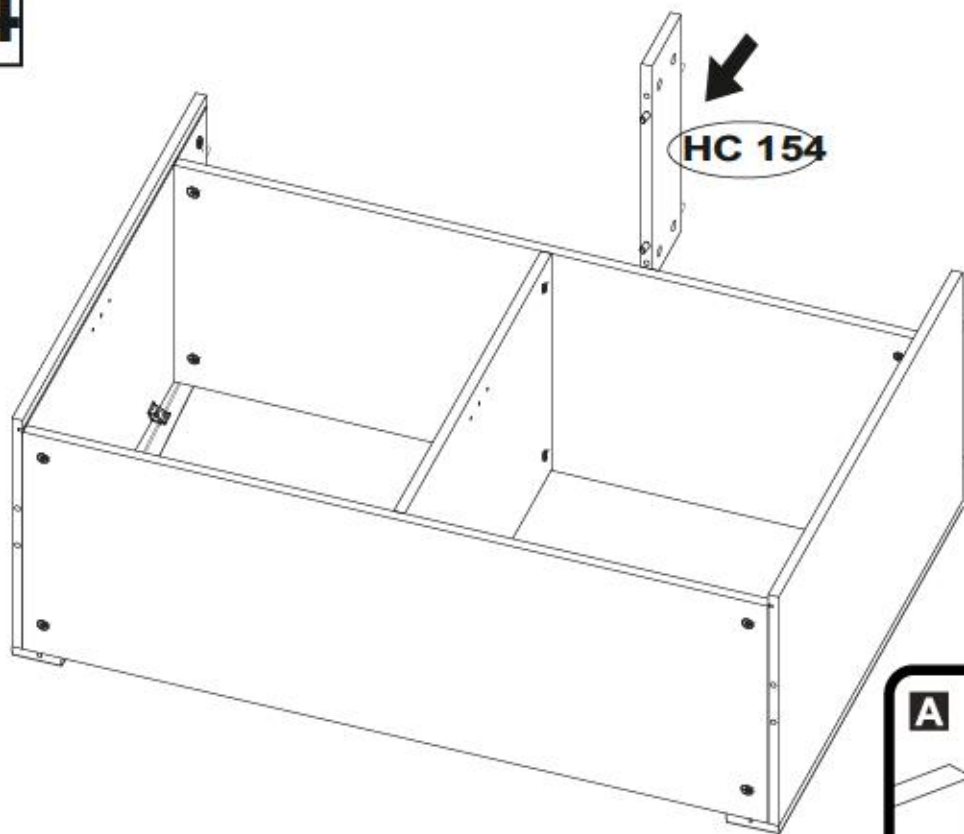

14



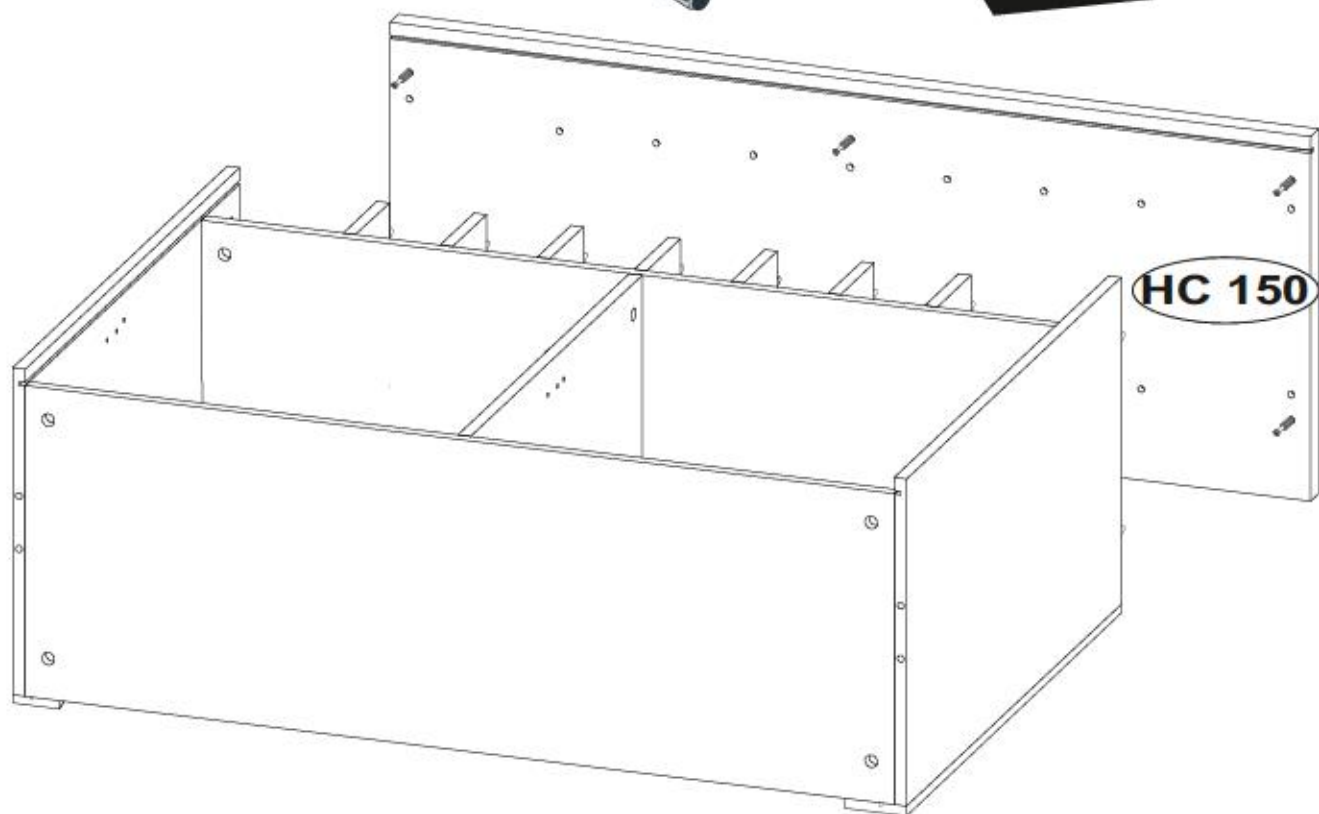
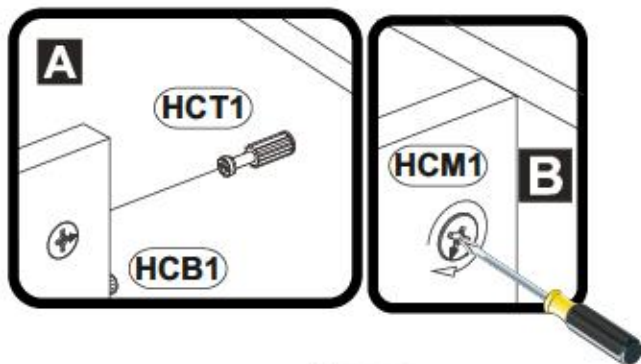





HCJ23		1302
		x8
HCP6		1099
	3x20	x21
HCF1		1415
		x5

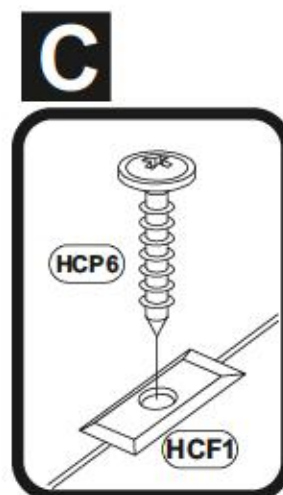
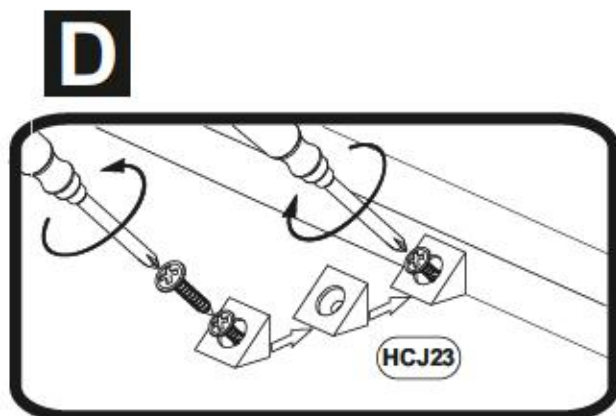
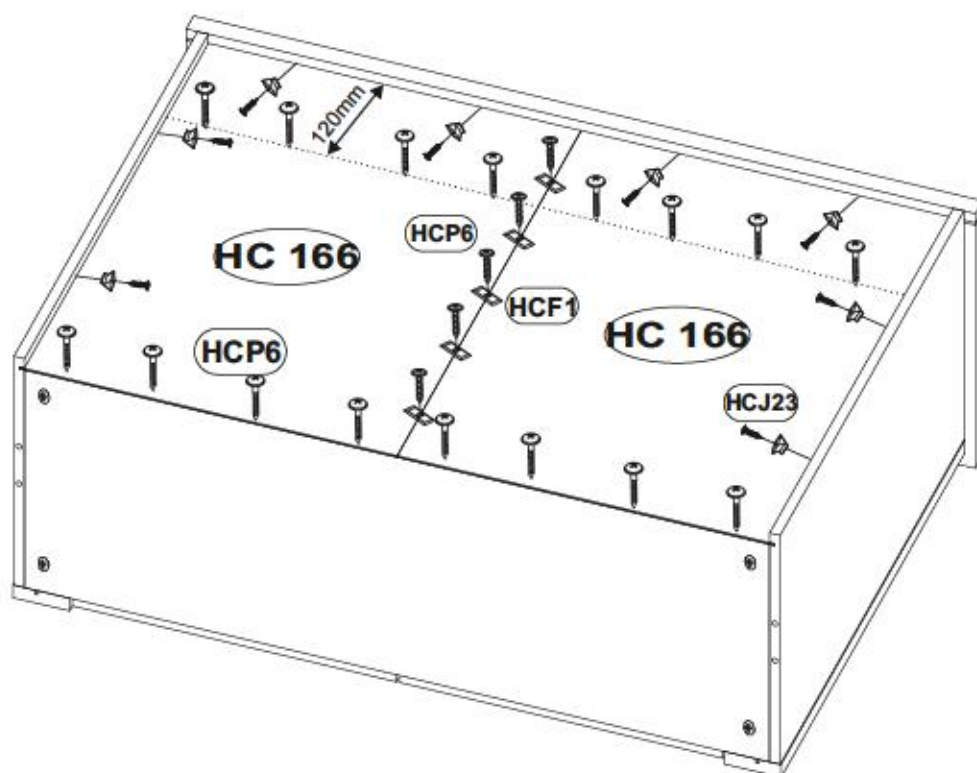
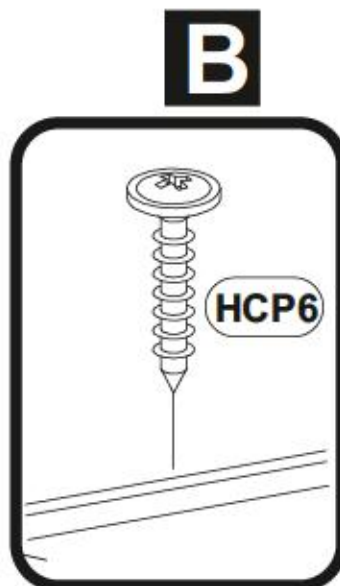
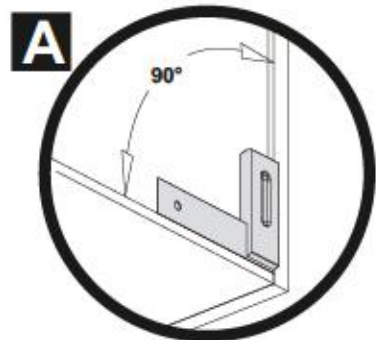

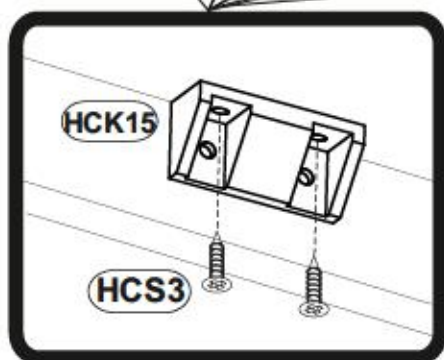
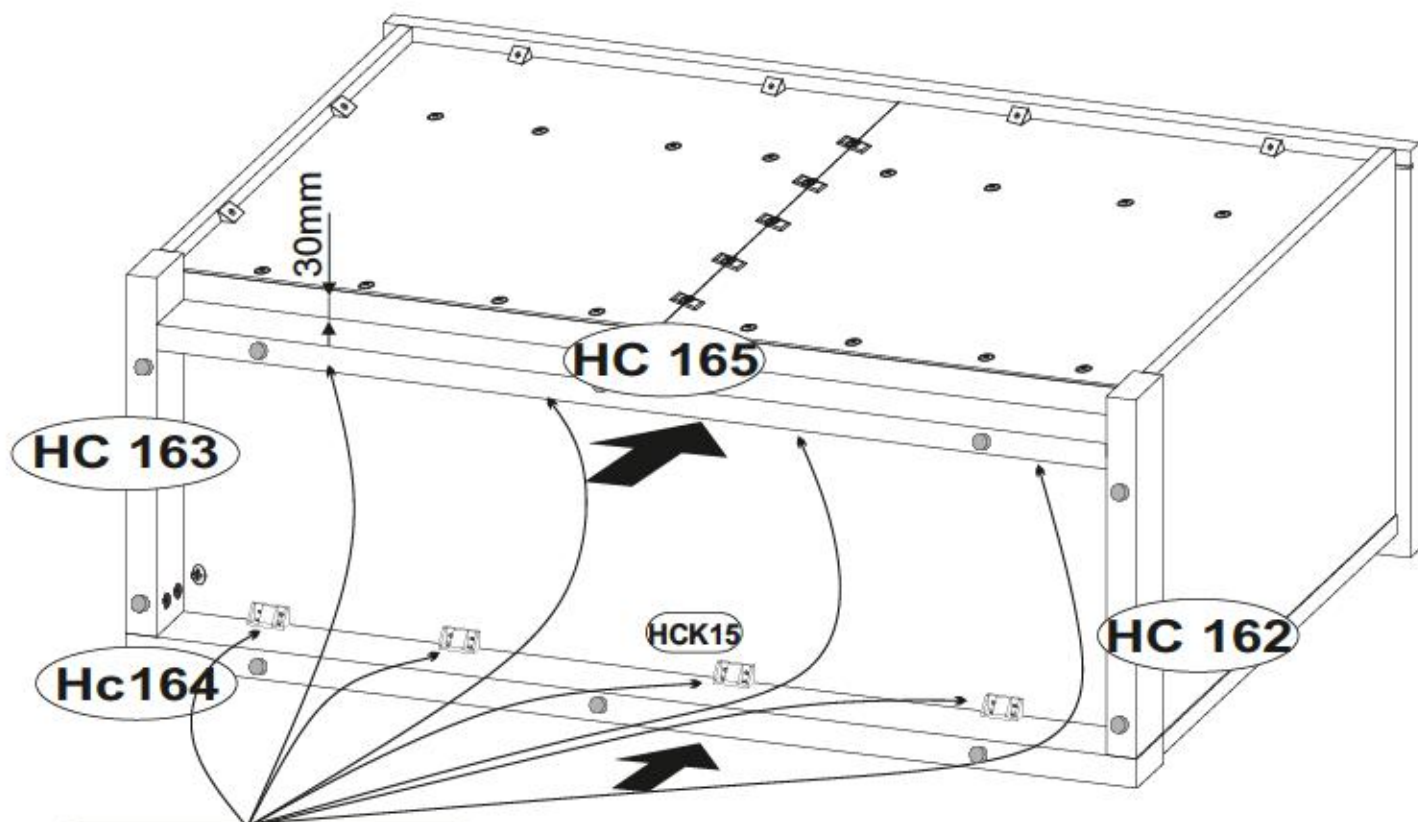

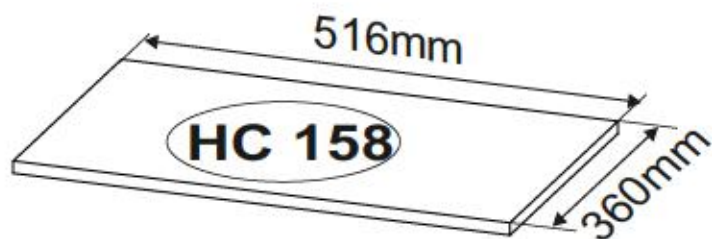
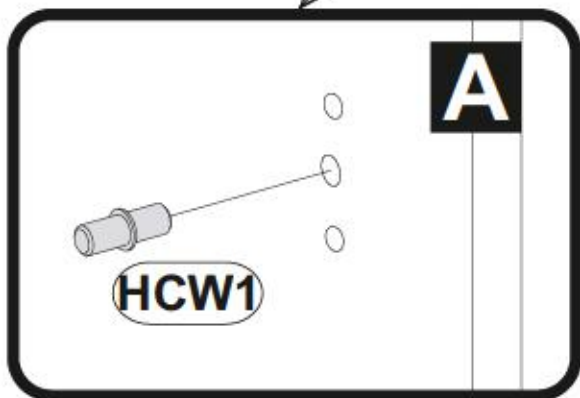
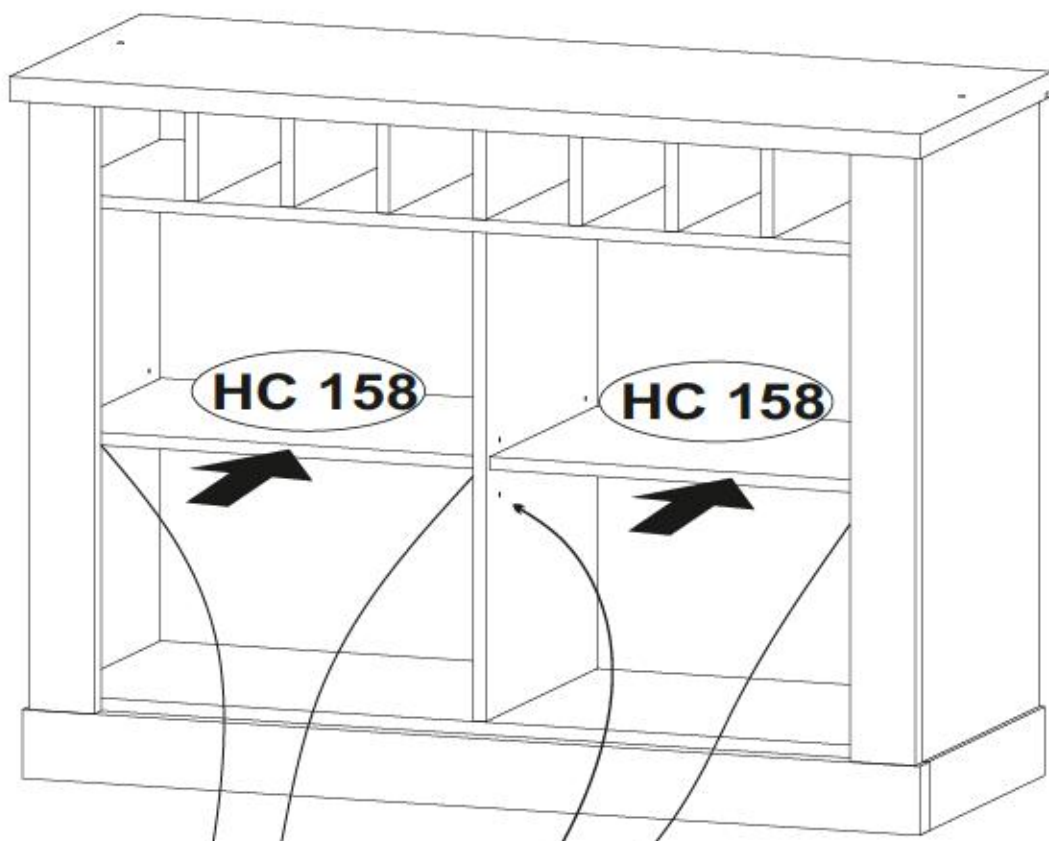

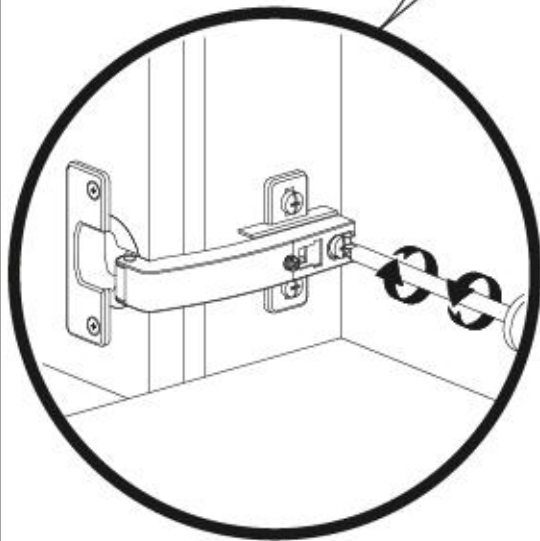
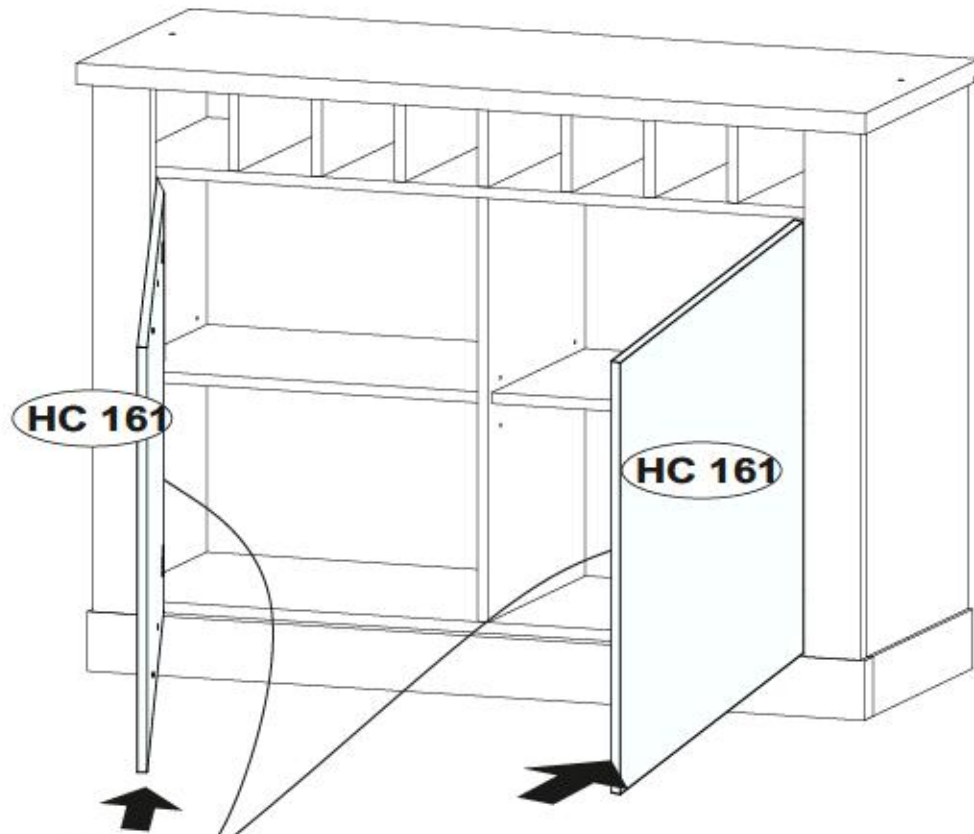

HCZ2 + HCD14

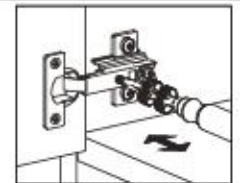
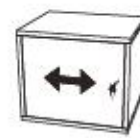
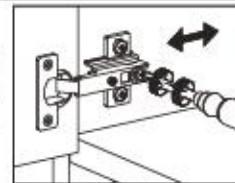
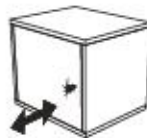
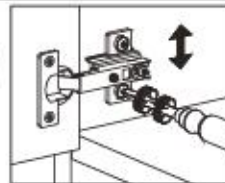
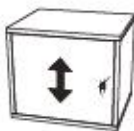

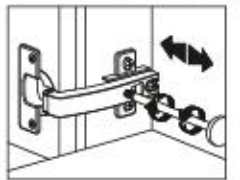
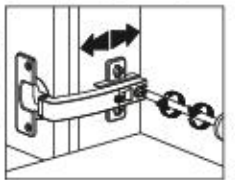
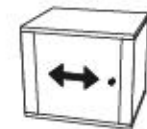
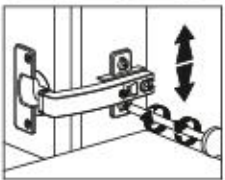
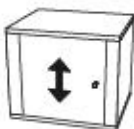

HCZ4 + HCD14

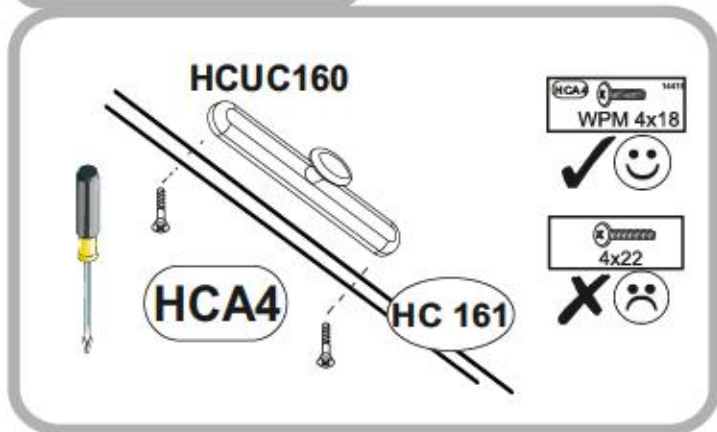
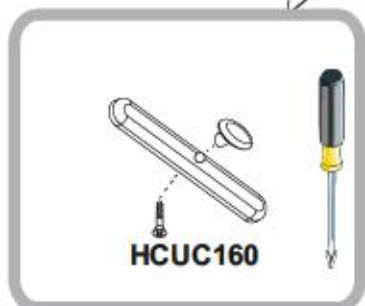
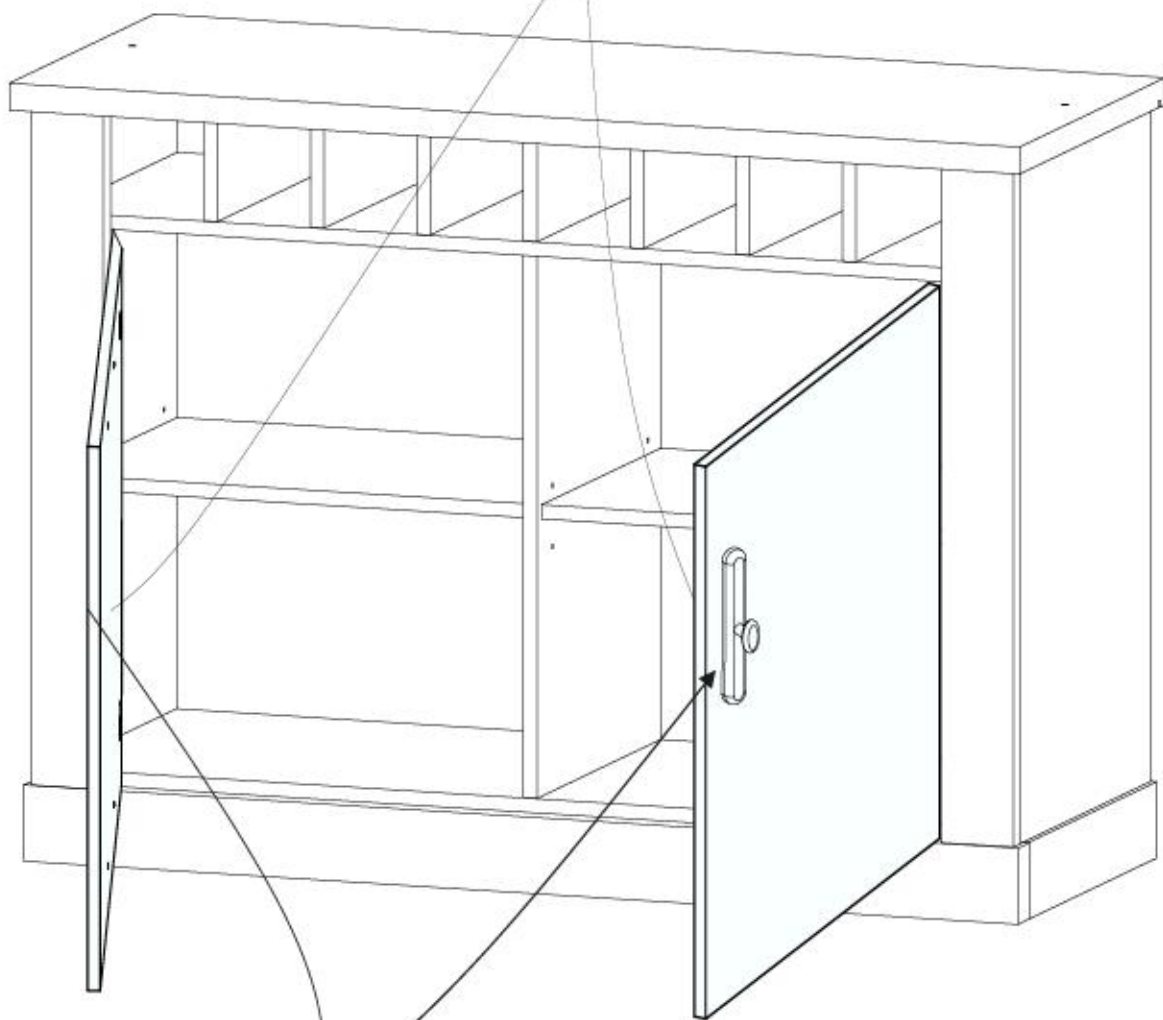
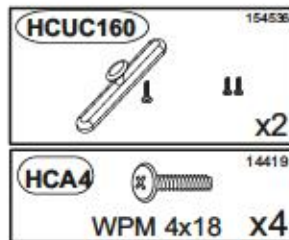
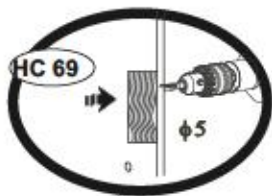





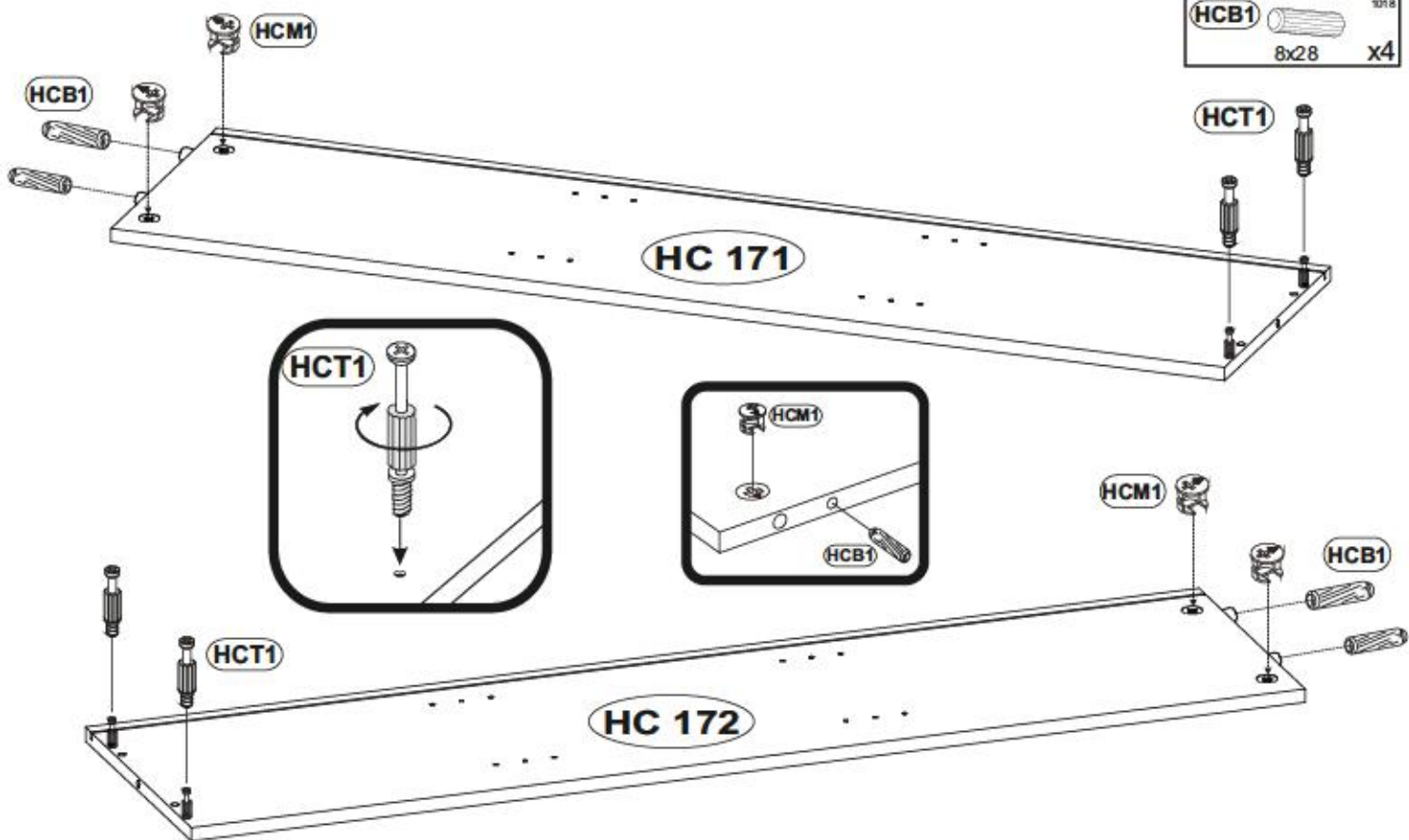

# 21

HCT1		11803
		x4
HCM1		123894
		x4
HCB1		1018
	8x28	x4



# 22

HCM1		123894
		x4
HCB1		1018
	8x28	x4

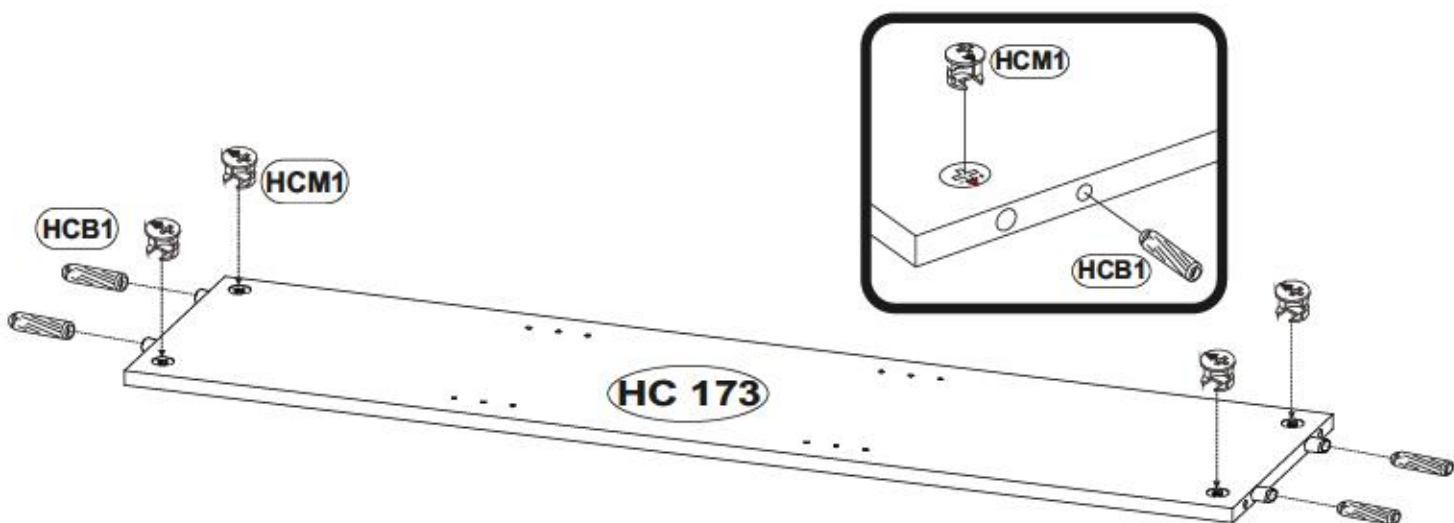

23

HCT1 11809  
x6

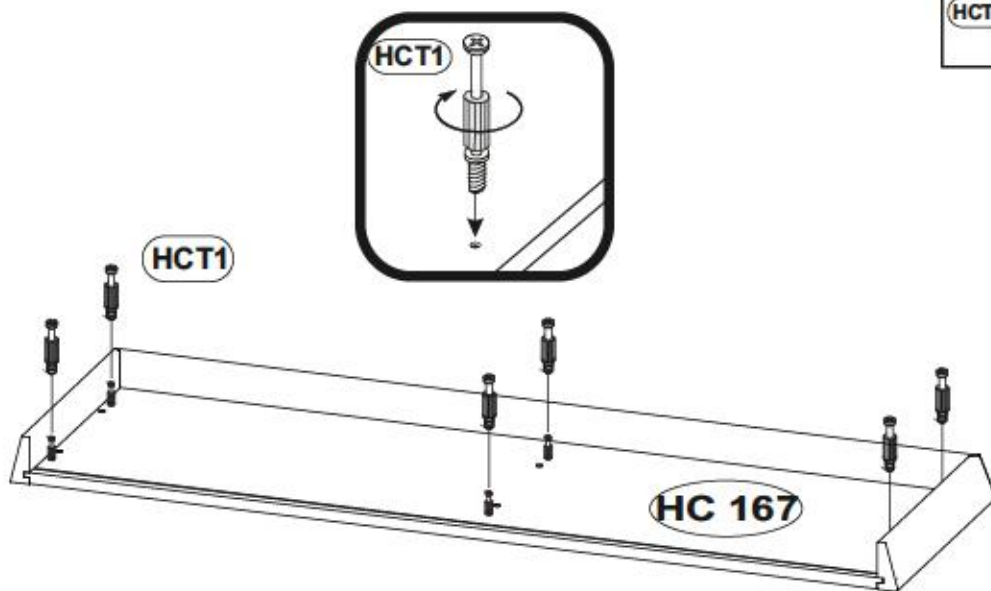

24

HCT1 11809  
x2

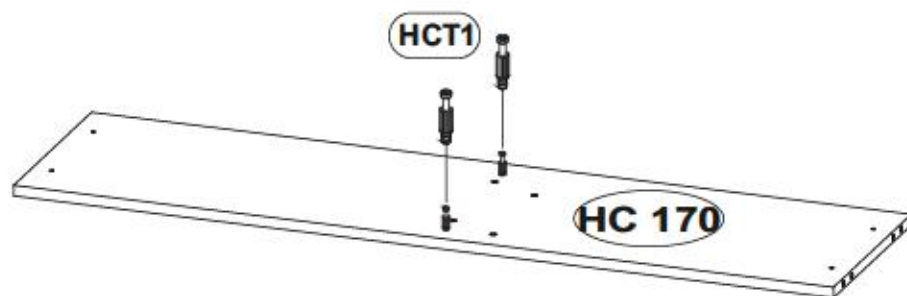

HCM1 123894  
x4

HCB1 1018  
8x28 x4

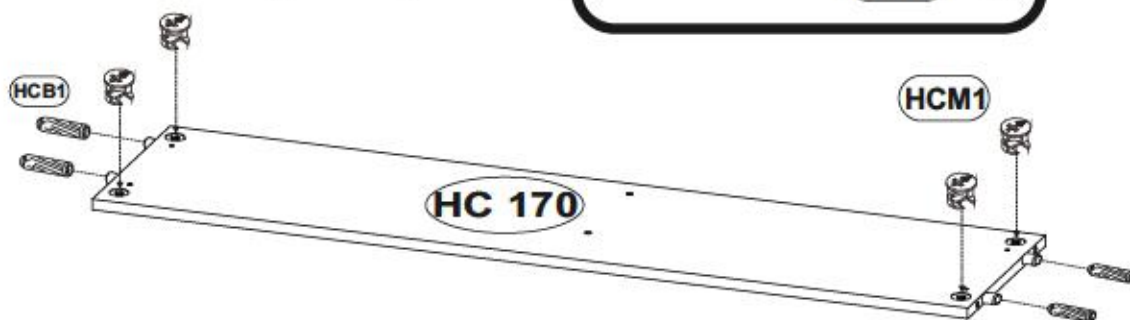
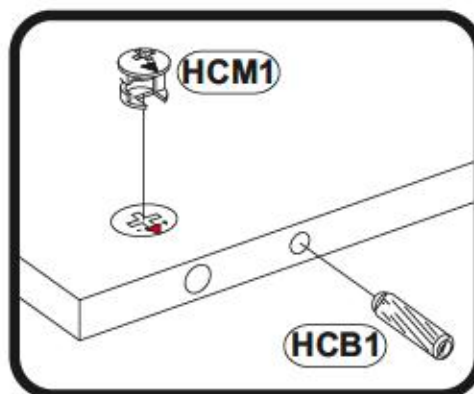

180°



HCK13		40718	x8
HCS3		1011	x16
HCD14		26618	x4

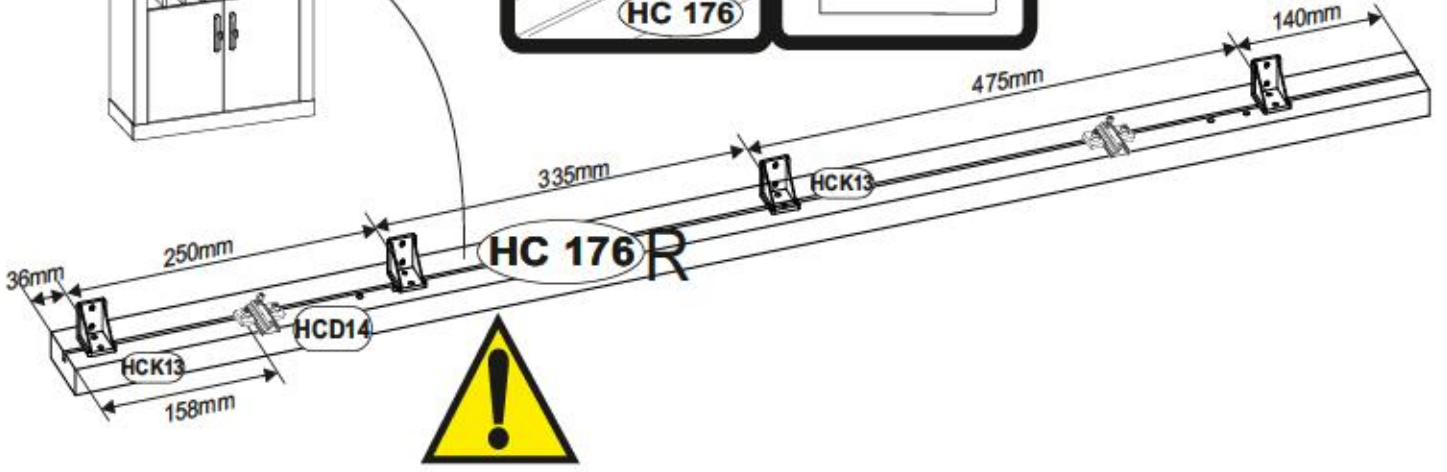
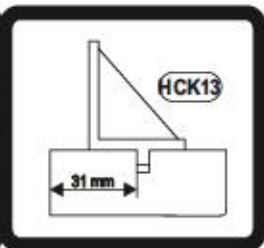
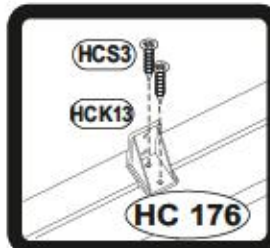
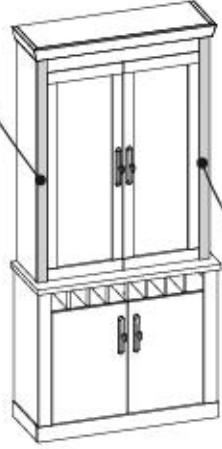
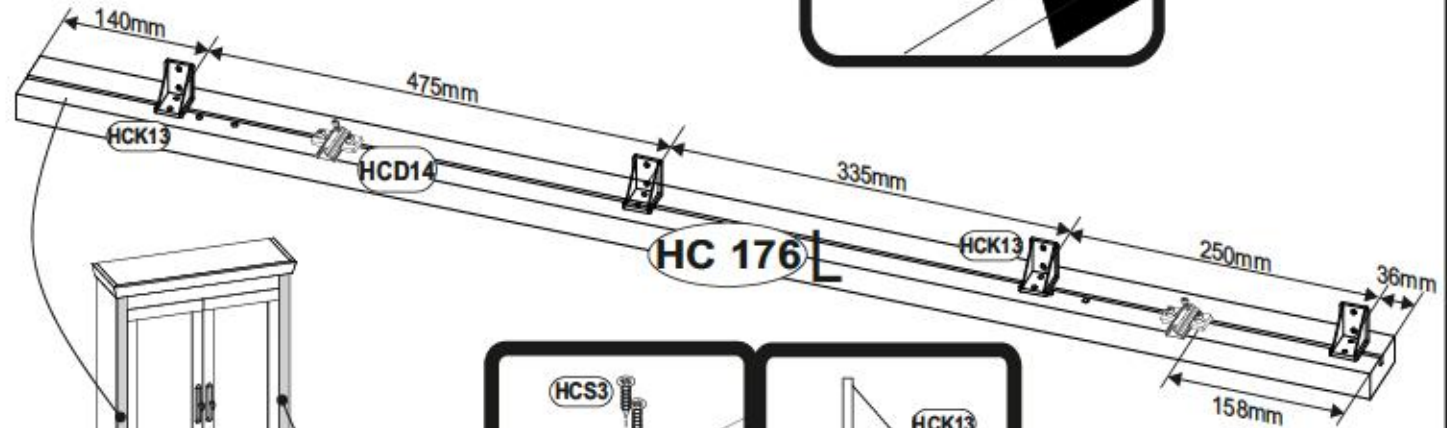
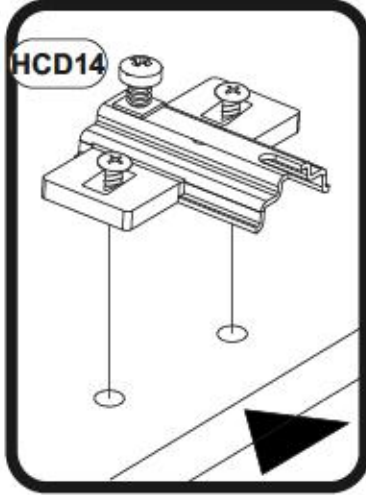

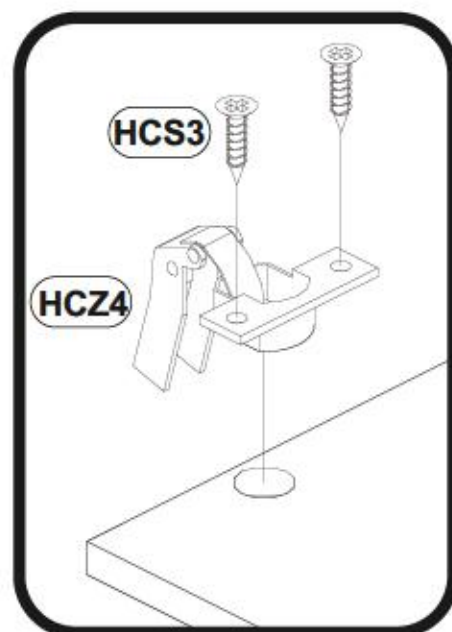
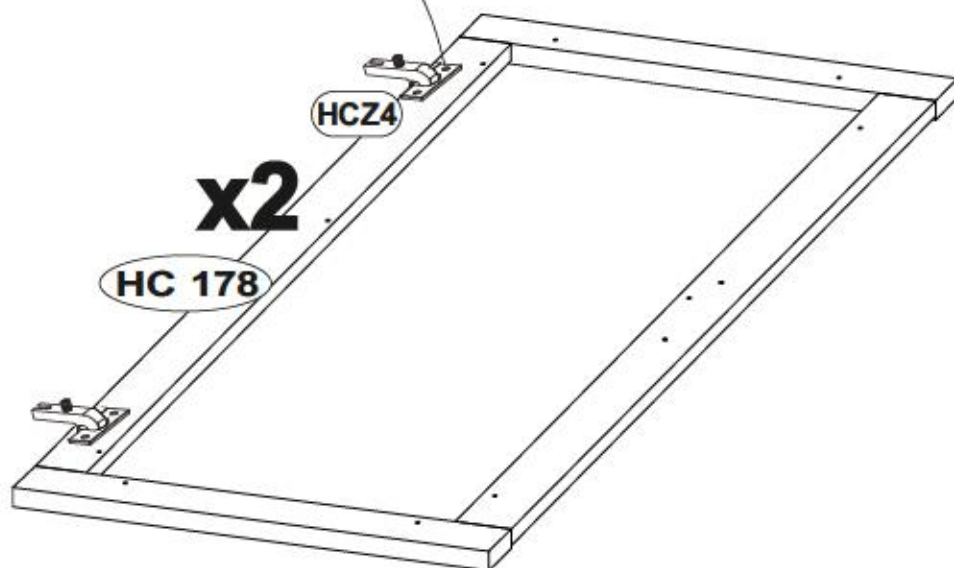
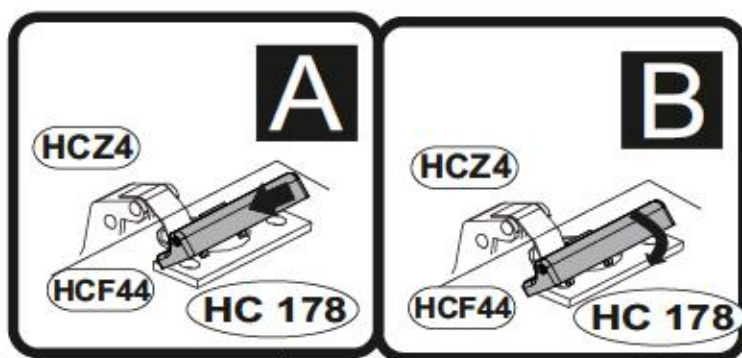
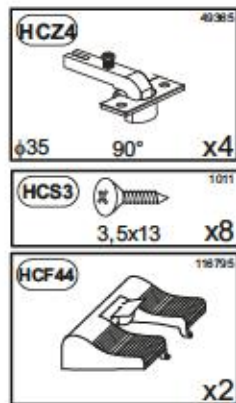

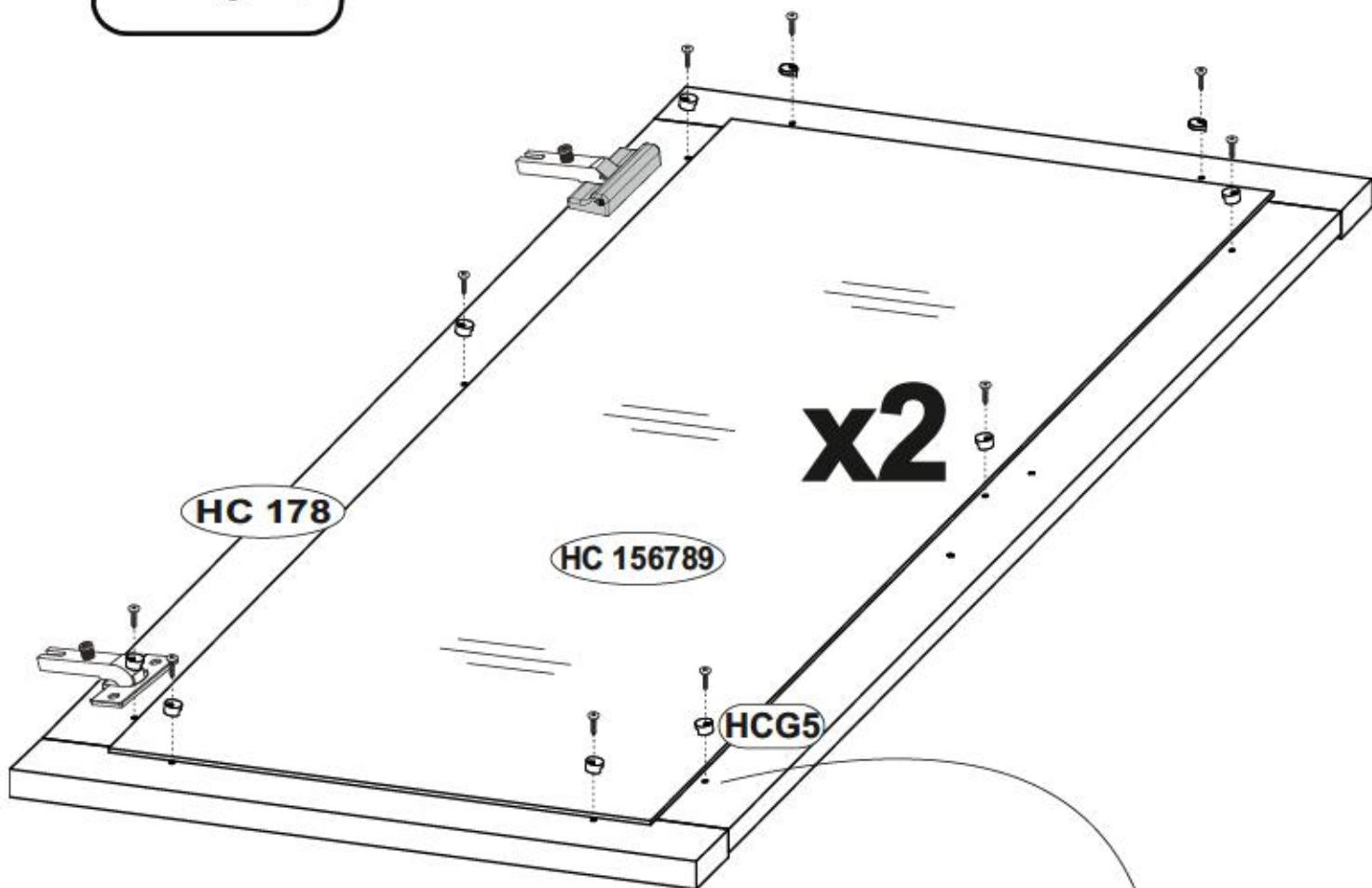



28

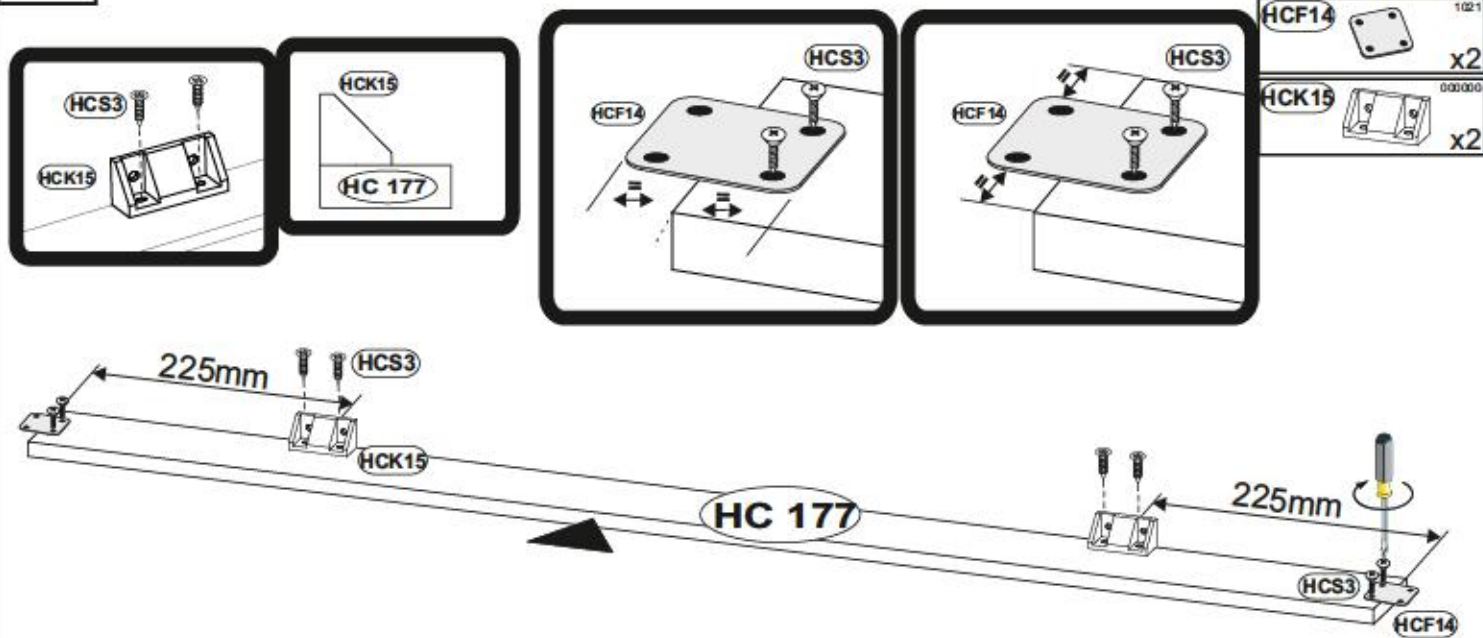

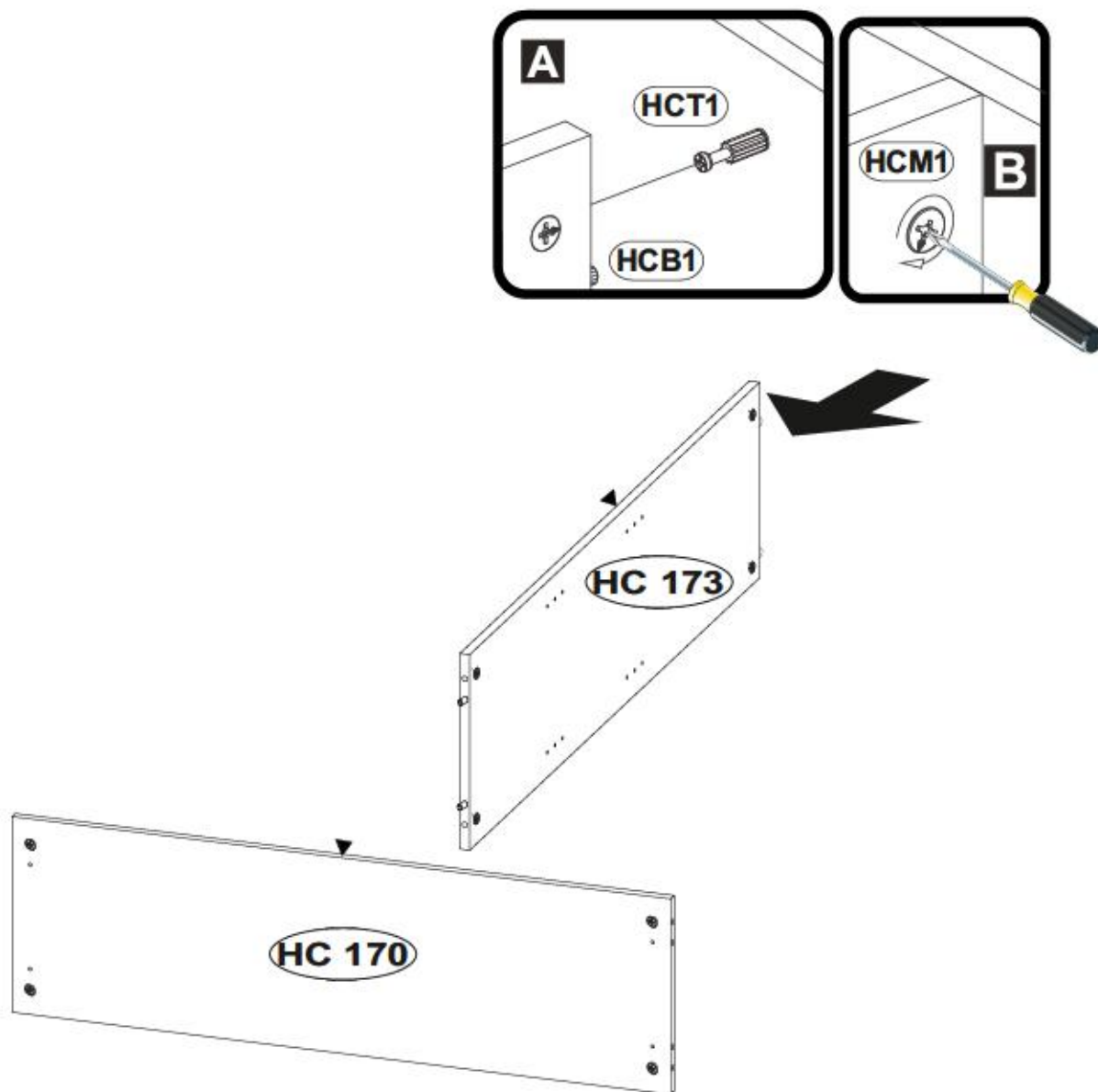

29

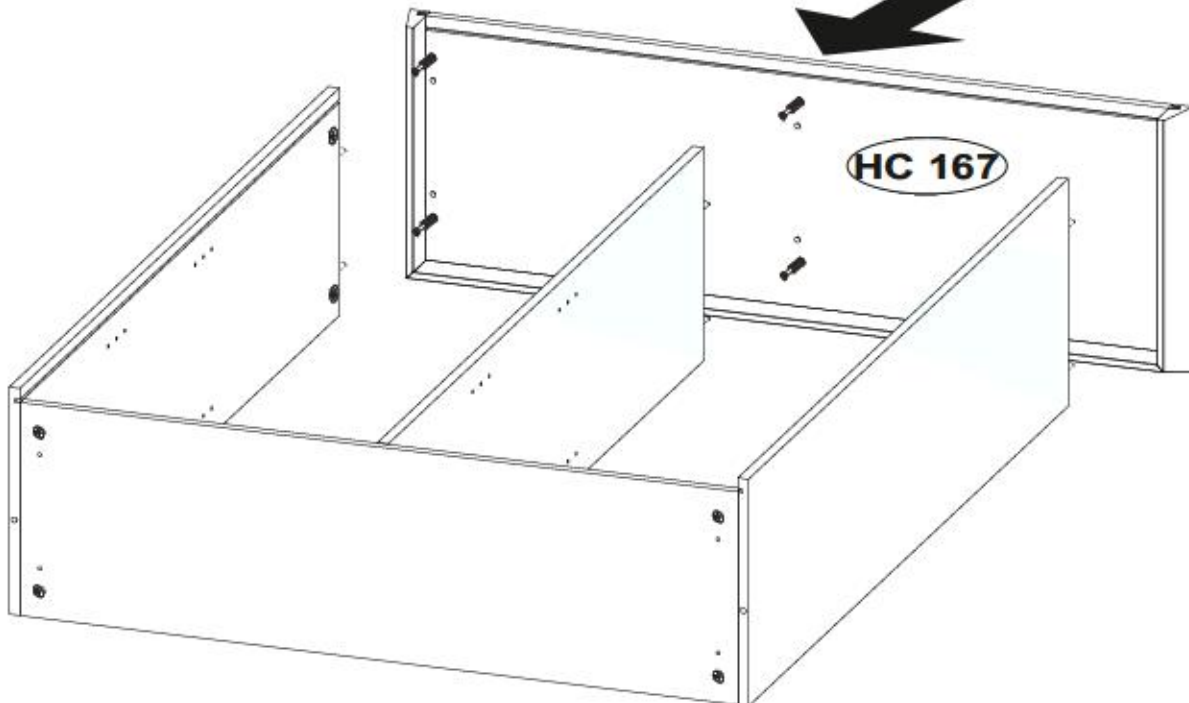
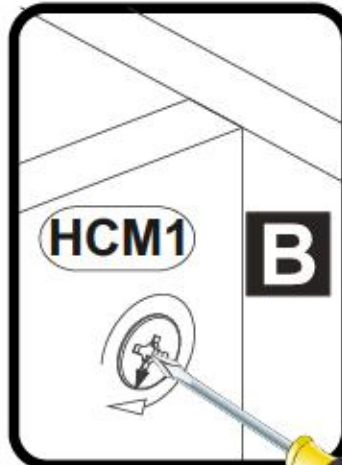
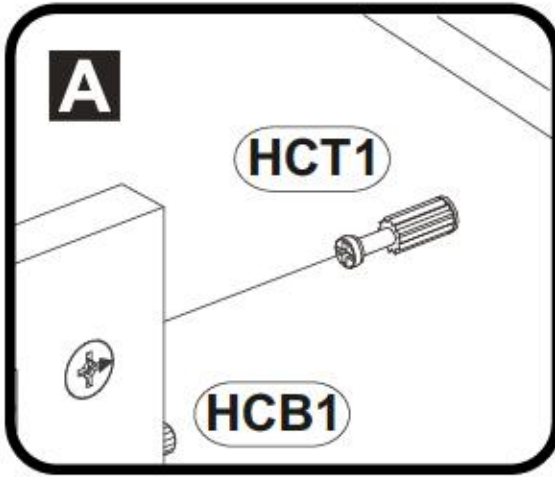
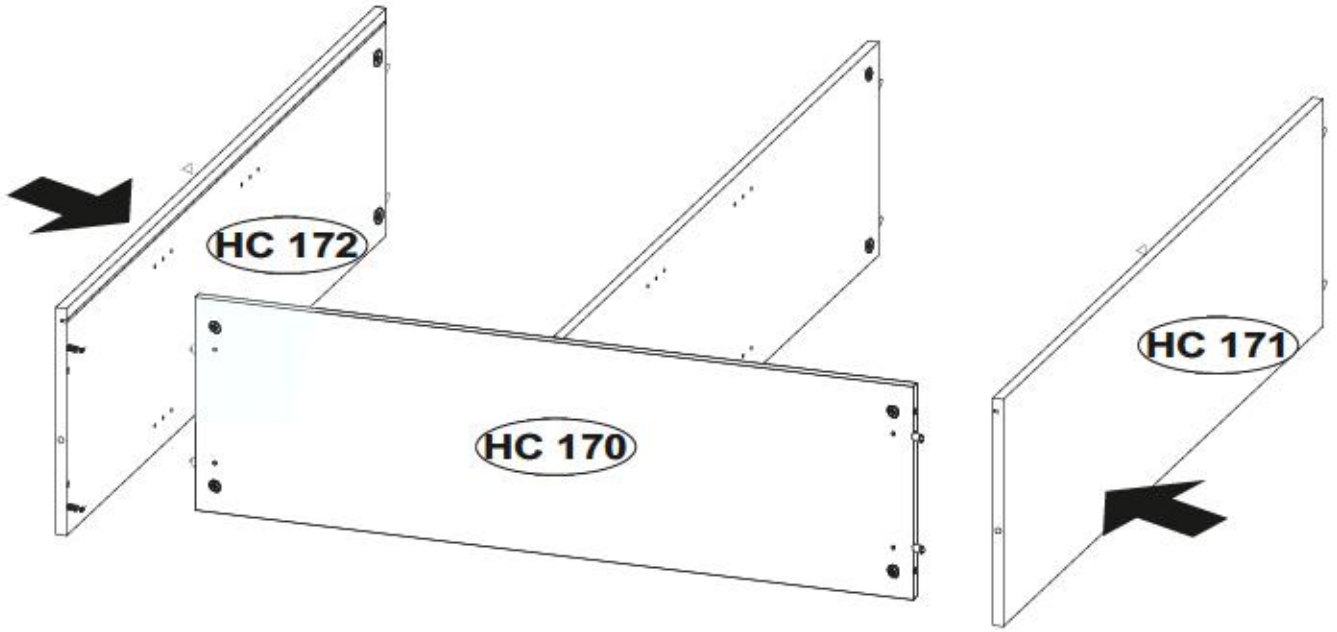

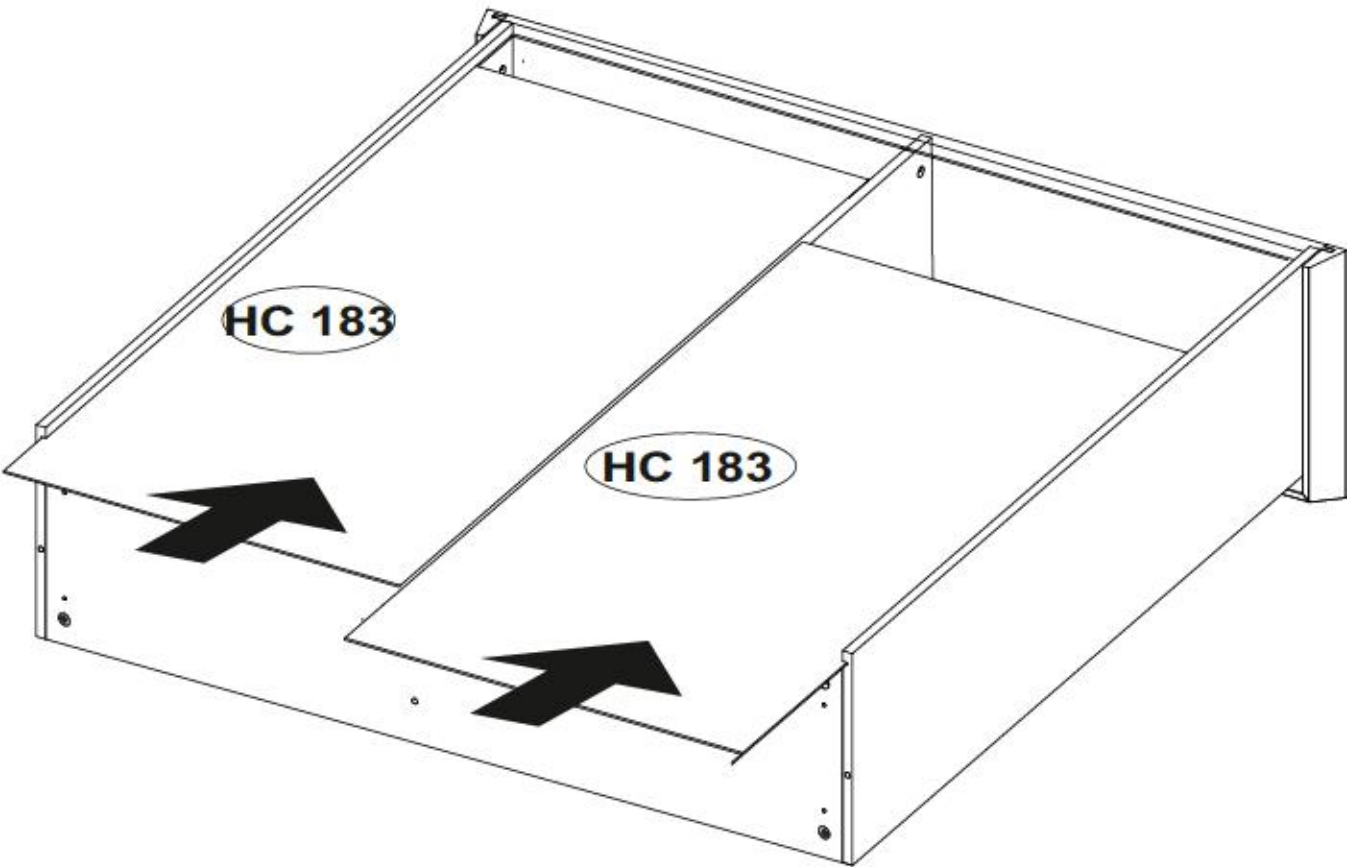



<b>HCP6</b>		1058
	3x20	x14
<b>HCJ23</b>		1302
		x12
<b>HCF1</b>		1415
		x6

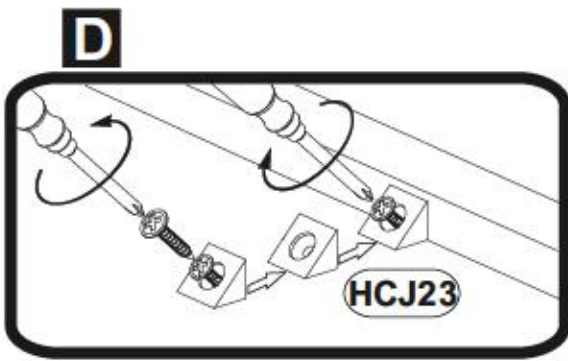
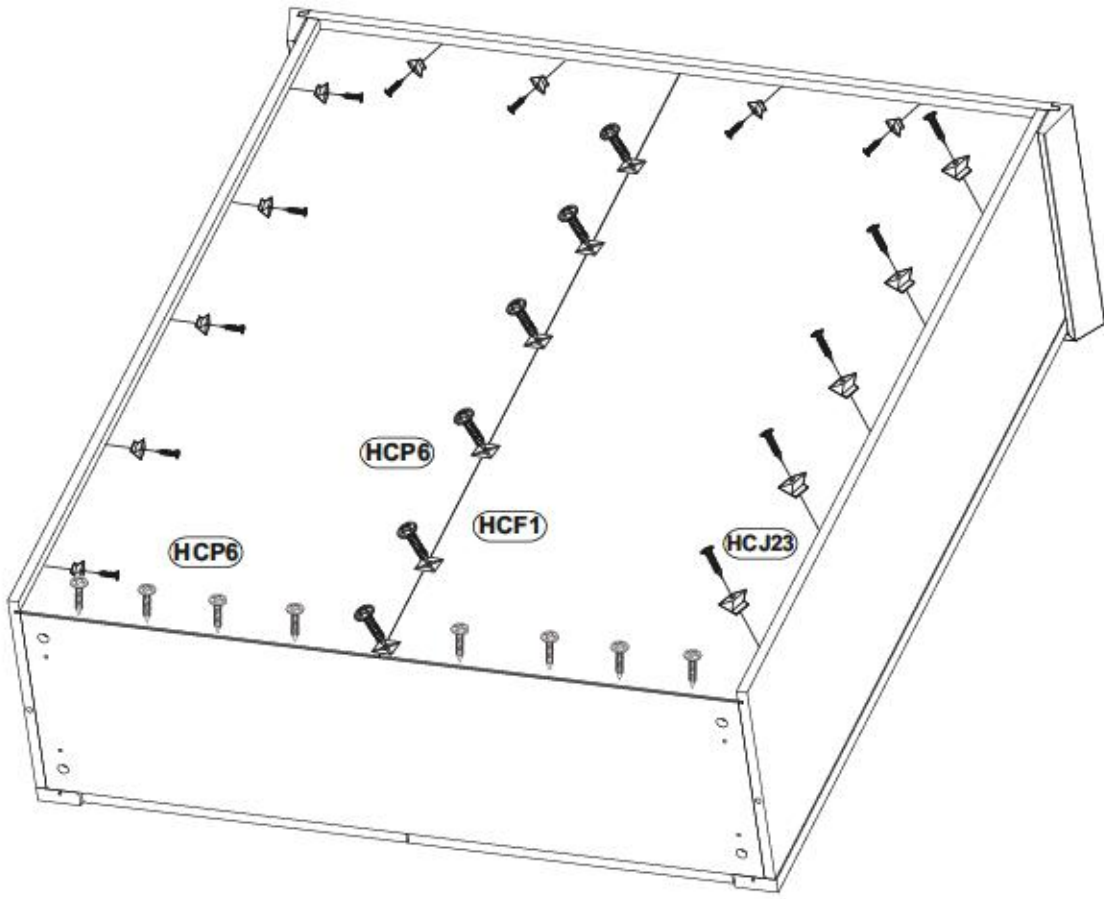
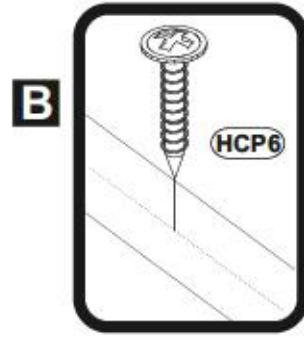
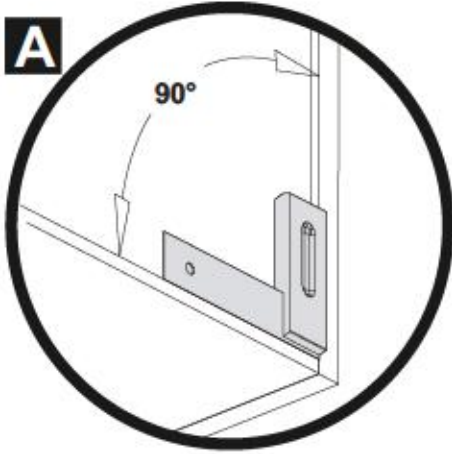

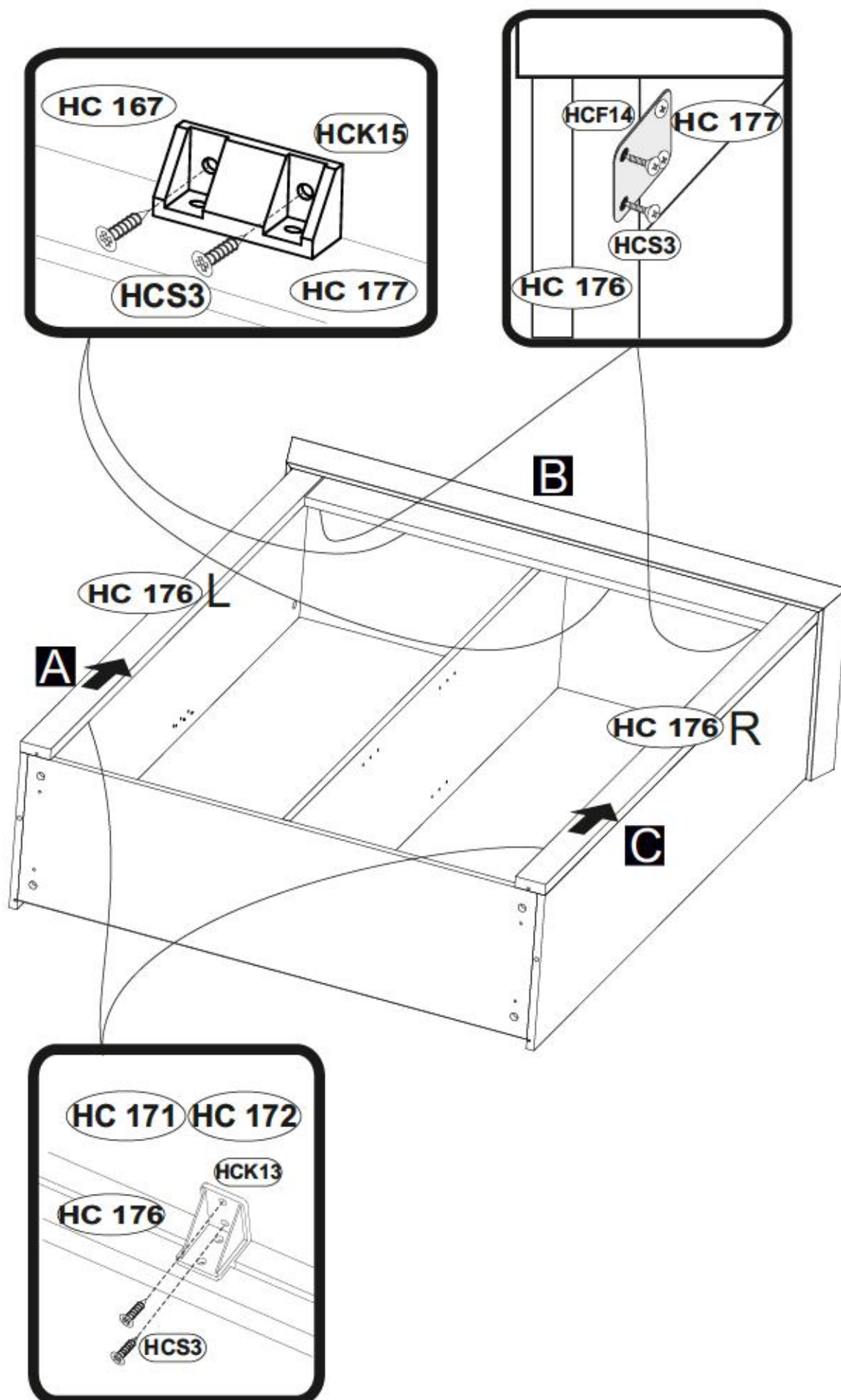



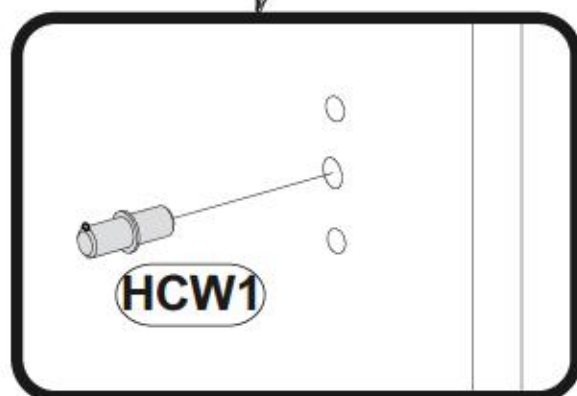
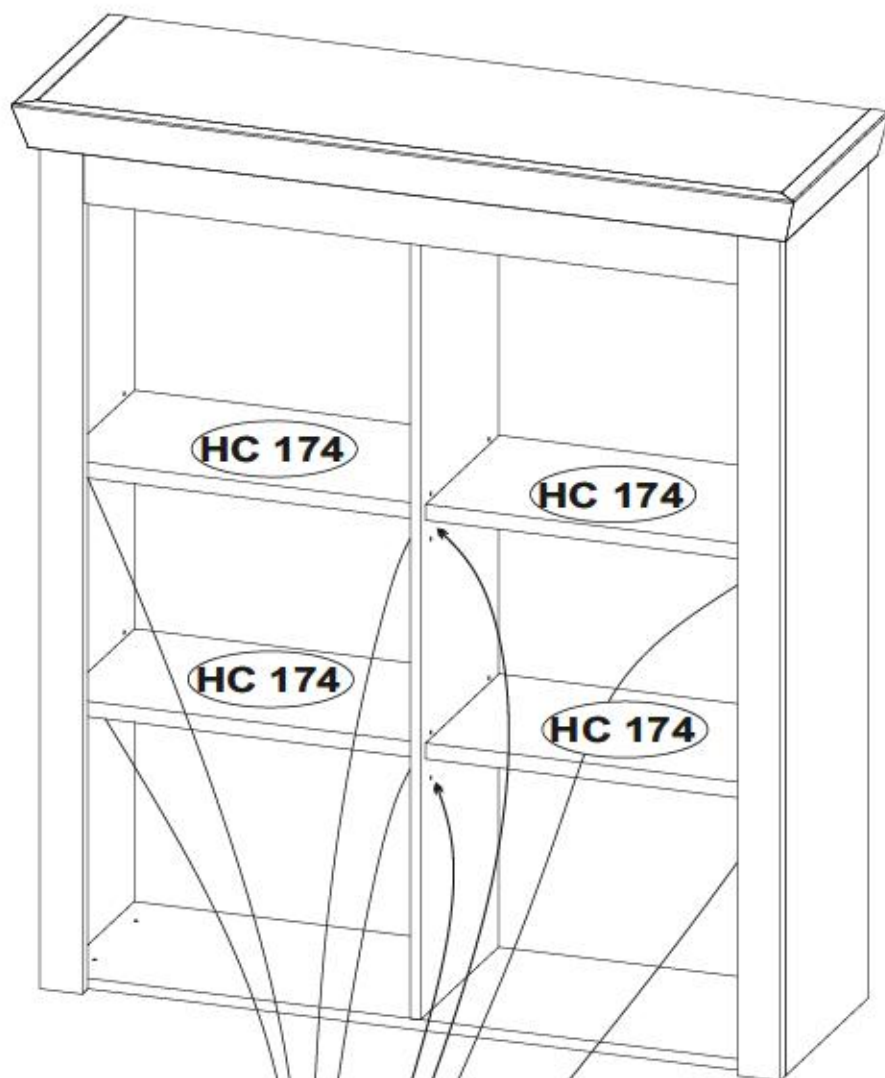



35

<b>HCUC160</b>		15433
	1	x2
<b>HCA4</b>		14419
	WPM 4x18	x4

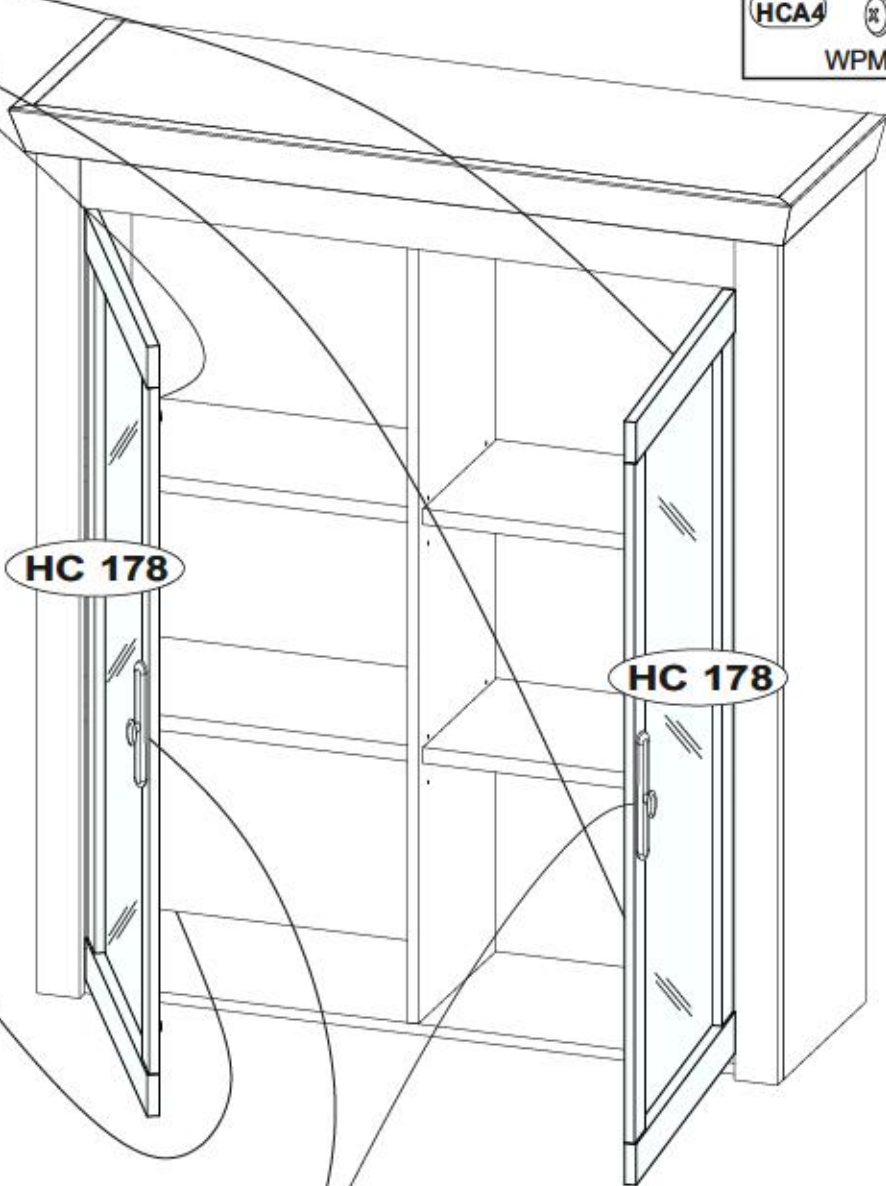
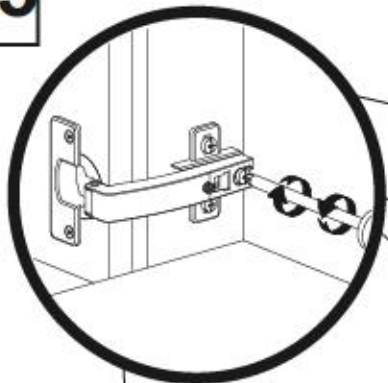

**A**

**HCUC160**

**HCUC160**

**HCA4**

**HC 178**

**WPM 4x18** ✓ ☺

**4x22** ✗ ☹

HCZA + HCD14

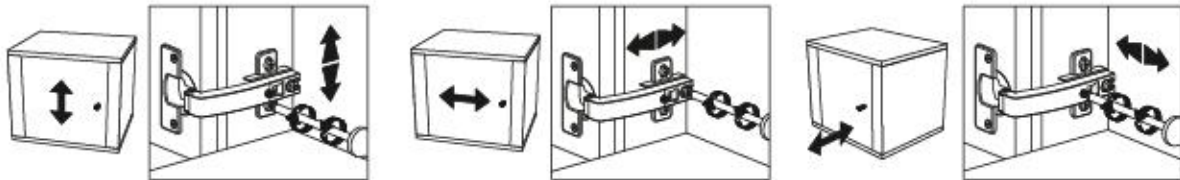

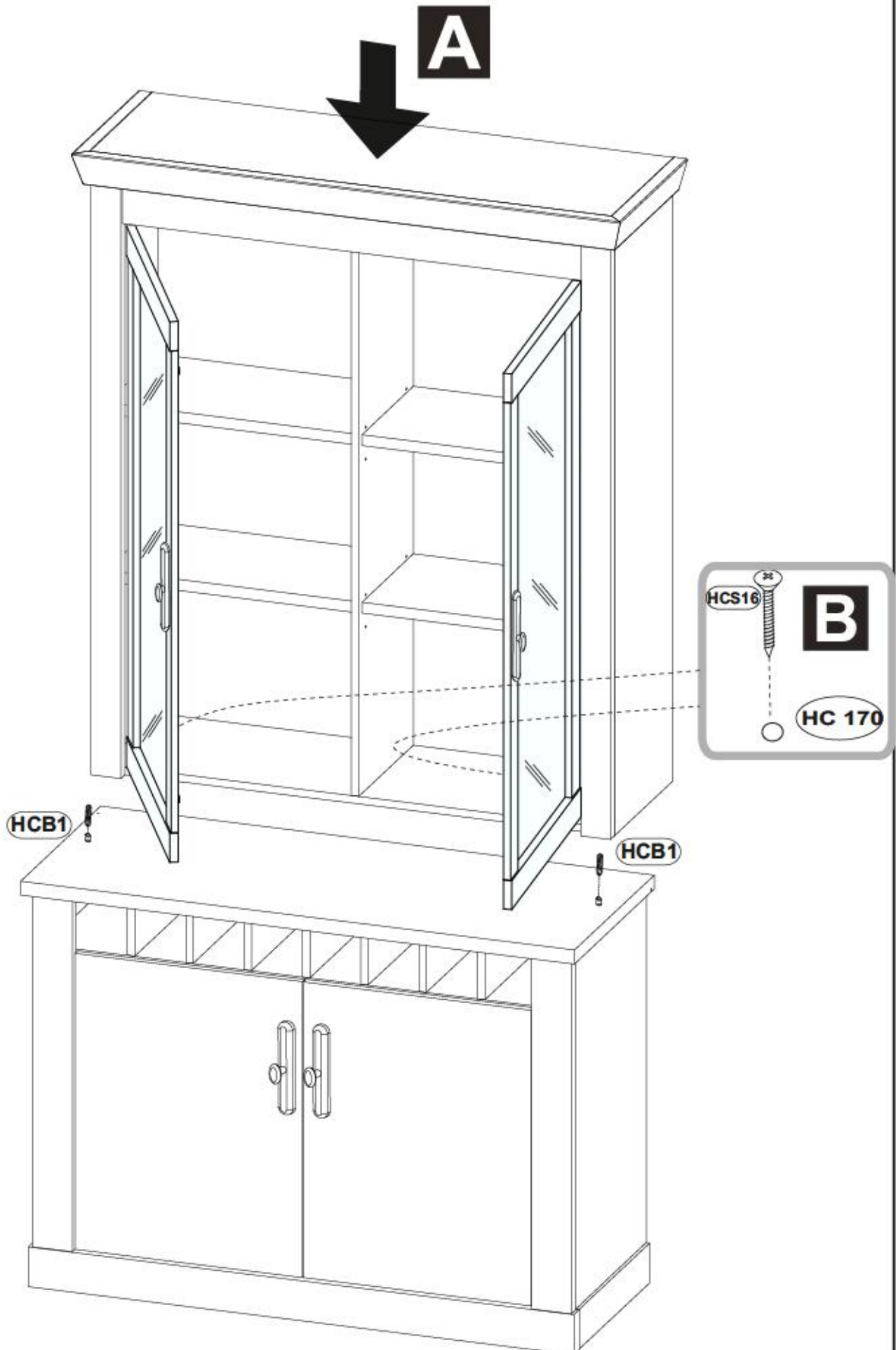
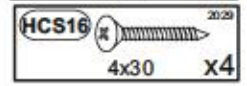
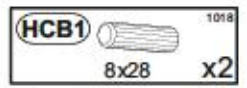

HCC6 140818  
 $\phi 20$  x24

HCCJ11 1267  
 x2

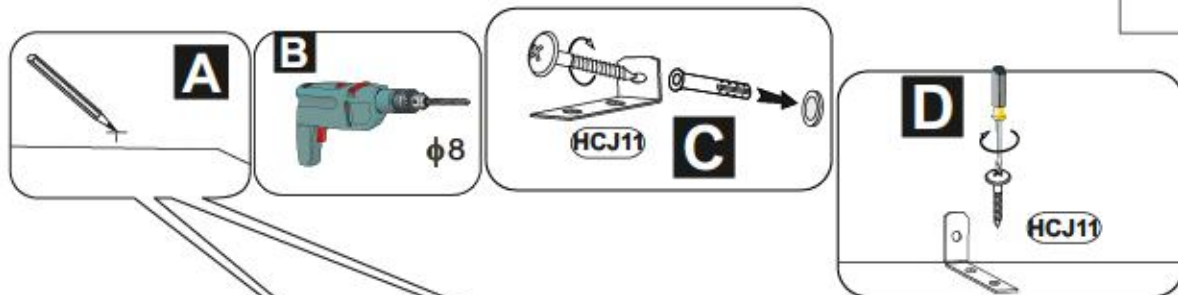

HC 167

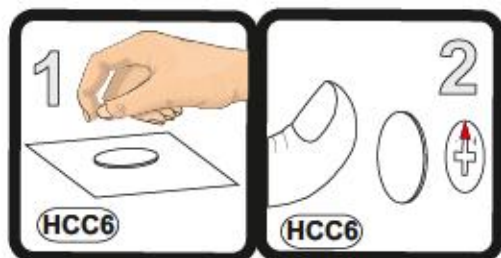
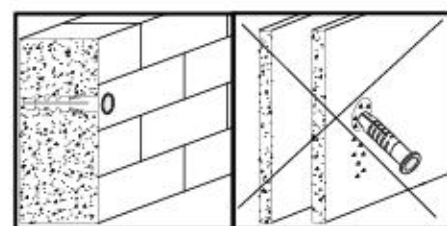
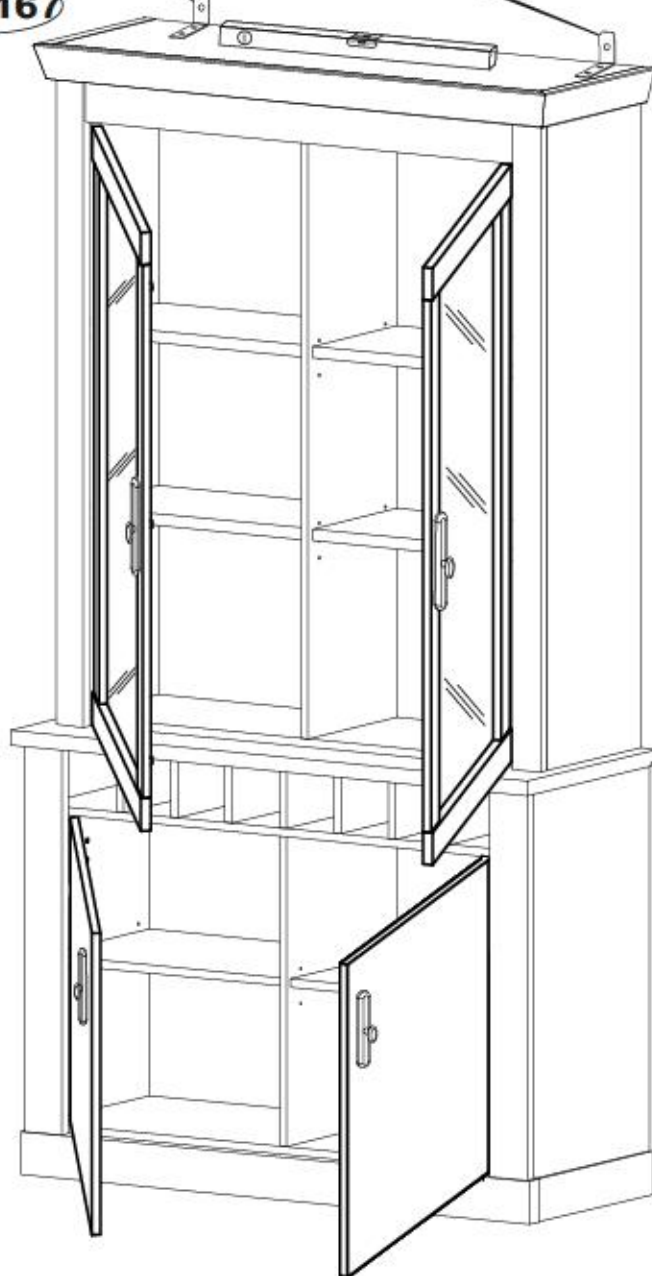



# RAVENNA 27

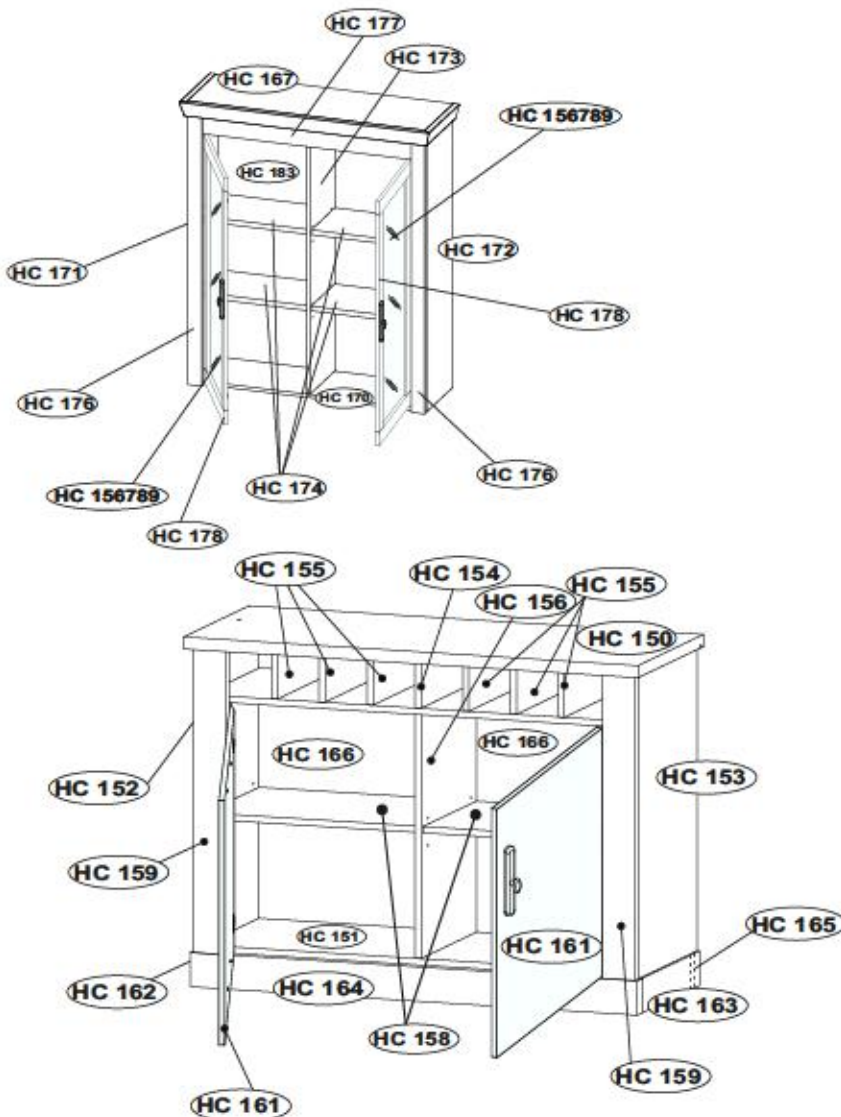

**D** Unser Kundenportal für Beschädigte  
Bitte Ihren wir Beschädigte haben, können Sie diese Servicekarte direkt an die Unschädlichen der Adresse senden. Wir können alle Fragen nur Beschädigte auf diesem Weg zu erreichen. Sollten Sie eine andere Beistandung an Ihrem Möbelstück haben, so werden sie sich bitte direkt an Ihr Möbelhaus.

**GB** Our direct order service for items  
If a fitting part is missing, you can e-mail this service card directly to the address below. However, we can only send fitting parts in this way. If you have any other cause for complaint concerning your item of furniture, please contact your furniture store directly.

**CZ** Než se přímá služba proškození  
Chybí-li vám nějaká díl z kování, můžete tuto službu kartu odešlat e-mailem přímo na náš uvedenou adresu. Tuto částku však můžeme poslat jen díly kování. Pokud byste měli jiné problémy, obraťte se přímo na svého prodejce nábytku.

**F** Service direct de votre casse ou déchet  
Si vous manque une ferrure, vous pouvez envoyer le directement la présente carte service à l'adresse e-mail indiquée ci-dessous. Cependant, nous ne pouvons uniquement d'envoyer des ferrures. Pour tout autre type de problème concernant votre meuble, vous devez contacter directement votre magasin d'ameublement.

**I** Il nostro servizio diretto per l'ordine delle ferrature  
Qualora vi dovesse mancare un pezzo di ferraggio, allora vi preghiamo di inviare questa carta di servizio tramite e-mail all'indirizzo indicato. Possiamo inviare i pezzi di ferraggio solamente per mezzo di questo procedimento. Qualora dovete avere qualche altra richiesta in merito al mobile, allora vi preghiamo di rivolgervi direttamente al Vostro Negozio di mobili.

**BG** Прямата директна услуга за обичайно  
Ако липне част от ковањето, можете да испратите картата директно на адресот на е-пошта, позначен подолу. По тој начин може да доставим само деловите на ковањето. За сè друго, вклучувајќи ја и барањето за замена на мебелот, отидете директно на вашиот продавач.

**NL** Onze direct dienst de voor onze schade  
Wanneer er een onderdeel ontbreekt, kunt u deze servicekaart direct aan onze adres e-mail adres sturen. Wij kunnen langzame de weg echter alleen bestelbare onderdelen. Mocht u een ander probleem met uw meubel hebben, verzaken wij u contact op te nemen met uw meubel dealer.

**PL** Nasza bezpośrednia usługa uszkodzeń  
Jeżeli brakuje części krawędziowych do montażu, prosimy o przesłanie nam niniejszej karty serwisowej na nasz podany adres e-mailowy. W ten sposób możemy przesłać wyłącznie te części krawędziowe, które są dostępne w naszym magazynie. W przypadku innych problemów z meblami, prosimy o kontakt z naszym sprzedawcą mebli.

**HR** Servis za oštećenje  
U slučaju da nedostaje neki od dijelova molimo vas da nas dalje ne vodite mail adresu pošaljete ovaj servisni obrazac. Na ovaj način možemo dostaviti samo dijelove za montažu. Za sva druga pitanja vezana uz vaš mebel molimo vas da se obratite izravno trgovini namještaja gdje je isti kupljen.

**HU** Közvetlen szolgáltatásunk sérülések esetén  
Ha hiányzik egy csavar, vagy más kiegészítő a szereléshez, kérjük, küldje el nekünk ezt a szolgálati kártyát az e-mail címre. Csak a csavarokat tudjuk elküldeni így közvetlenül. Amennyiben másféle problémák állnak fenn a bútorteljesítéssel kapcsolatban, forduljon közvetlenül a bolti eladóhoz.

**SK** Naša priama služba pre škody  
Ak vám chýba niektorá časť kováčstva, môžete poslať túto službu kartu pošlou e-mailom na náš uvedenú adresu. Dielky kováčstva vieme poslať iba týmto spôsobom. Ak by ste mali iné problémy s nábytkom, obráťte sa priamo na Vašu predajňu nábytku.

**SLO** Než se přímá služba proškození  
Če vám manque nějaká součást kování, můžete tuto službu kartu poslat e-mailem přímo na naši uvedenou adresu. Tuto částku však můžeme poslat jen díly kování. Pokud byste měli jiné problémy, obraťte se přímo na svého prodejce nábytku.

**RO** Servis direct de la rupa sau defect  
In cazul in care va lipseste o piesa de fiermetrie puteti sa trimati direct o astfel de service prin e-mail la adresa de mai jos. Noi nu putem trimite piesa de fiermetrie decat pe o astfel de cale. Daca aveti o alta reclamație în legătură cu piesa de mobilier, atunci vă rugăm să vă adresați direct la magazinul dvs. de mobilier.

**RUS** Прямая служба для повреждений фурнитуры  
Если отсутствует, что либо из элементов того или иного элемента из фурнитуры, вы можете отправить сервисную карту по адресу ниже. Однако, мы сможем отправить только те детали фурнитуры, которые есть в наличии. Если у вас есть другие вопросы относительно приобретения мебели, пожалуйста, обратитесь непосредственно к продавцу мебели.

**S** Než se přímá služba proškození  
Čim du vám chýba niektorá časť kováčstva, môžete túto službu kartu poslať e-mailom na náš uvedenú adresu. Tuto časť však môžeme poslať iba kováčstvom. Ak by ste mali iné problémy s nábytkom, obráťte sa priamo na Vašu predajňu nábytku.

**ES** Nuestro servicio directo para averías  
Si le falta algún accesorio, puede enviar esta tarjeta de servicio directamente a la siguiente dirección. No obstante, por este método solo podemos enviar accesorios. Si tiene alguna otra objeción sobre su mueble, consulte directamente con su mueblería.











**TR** Doğrudan hizmet için hasar kartı  
Bir donanım aksesuarı veya aksesuar kartını doğrudan aşağıdaki bu adres adresine göndermek için bu kartı kullanabilirsiniz. Ancak, bu yöntemle sadece mevcut aksesuarları gönderebiliriz. Mobilyanızla ilgili diğer problemler için doğrudan mobilya satıcınıza danışın.

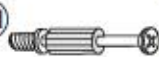



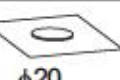

HC 150	x1	1111	440	28	2/3
HC 151	x1	1049	375	15	3/3
HC 152	x1	711	395	15	1/3
HC 153	x1	711	395	15	1/3
HC 154	x1	112	373	15	2/3
HC 155	x6	112	373	15	2/3
HC 156	x1	569	373	15	3/3
HC 157	x1	1049	374	15	3/3
HC 158	x2	516	360	15	3/3
HC 159	x2	711	80	22	1/3
HC 161	X2	593	456	15	2/3
HC 162	x1	392	80	28	2/3
HC 163	x1	392	80	28	2/3
HC 164	X1	1094	80	28	1/3
HC 165	x1	1036	80	28	2/3
HC 166	x2	716	530	2.5	1/3



HC 167	x1	1102	371	65	1/3
HC 170	x1	1011	300	15	1/3
HC 171	x1	1236	320	15	3/3
HC 172	x1	1236	320	15	3/3
HC 173	x1	1221	300	15	3/3
HC 174	x4	497	273	22	1/3
HC 176	x2	1236	60	22	1/3
HC 177	x1	921	124	18	2/3
HC 178	x2	1106	456	18	2/3
HC 183	x2	1240	511	2.5	1/3
HC 156789	x2	1016	366	4	2/3

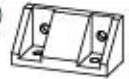
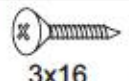

# RAVENNA 27

<b>HC B1</b>		1018
	8x28	X...
<b>HCM1</b>		123894
		X...
<b>HCT1</b>		11809
		X...
<b>HCJ23</b>		1302
		X...
<b>HCF14</b>		1021
		X...
<b>HCF36</b>		1305
		X...
<b>HCC6</b>		140318
	φ20	X...
<b>HCUC160</b>		154830
		X...
<b>HCW1</b>		1289
		X...
<b>HCG5</b>		1358
		X...

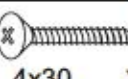
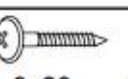
<b>HCD14</b>		23515
	H4	X...
<b>HCZ4</b>		49365
	φ35 90°	X...
<b>HCK15</b>		81556
		X...
<b>HCS11</b>		1073
	3x16	X...
<b>HCF44</b>		116795
		X...
<b>HCJ11</b>		1287
		X...
<b>HCA4</b>		14419
	WPM 4x18	X...

<b>HCK13</b>		49716
		X...
<b>HCS16</b>		2029
	4x30	X...
<b>HCP6</b>		1058
	3x20	X...
<b>HCF1</b>		1415
		X...
<b>HCS3</b>		1011
	3,5x13	X...

**D** Unser Kundendienst für Beschädigte  
 Sollte Ihnen ein Beschädigtes fallen, können Sie dieses Servicecenter direkt an die untenstehende Adresse melden. Wir können allerdings nur Beschädigte auf diesem Wege verschicken. Sollten Sie eine andere Beauftragung an Ihrem Möbelstück haben, so werden sie sich bitte direkt an Ihr Möbelhaus.

**GB** Our direct order service for fitting  
 If a fitting part is missing, you can e-mail this service card directly to the address below. However, we can only send fitting parts in this way. If you have any other cause for complaint concerning your item of furniture, please contact your furniture store directly.

**CZ** Naše přímé služby pro montáž  
 Chybí-li vám nějaký díl z kování, můžete tuto službu využít také e-mailem přímo na níže uvedenou adresu. Tuto částku však můžeme poslat jen tímto způsobem. Pokud byste měli nějaký jiný problém, obraťte se přímo na svého prodejce nábytku.

**F** Service direct de montage  
 Si vous manquez une ferrure, vous pouvez envoyer directement la présente carte service à l'adresse ci-dessous. Cependant, nous ne pouvons vous fournir que des ferrures de montage par ce moyen. Pour tout autre type de réclamation concernant votre meuble, veuillez contacter directement votre magasin d'ameublement.

**I** Il nostro servizio diretto per l'ordine delle ferramenta  
 Qualora vi dovesse mancare un pezzo di fissaggio, allora vi preghiamo di inviare questa carta di servizio (tramite la presente all'indirizzo sottostante). Possiamo inviare i pezzi di fissaggio solamente per mezzo di questo procedimento. Qualora dovete avere qualche altra richiesta in merito al mobile, allora vi preghiamo di rivolgervi direttamente al Vostro Negozio di mobili.

**BG** Прямия директен уред за монтаж  
 Ако липне част от кованата, попълнете настоящата сервисна карта или изпратете на е-мил адреса, посочен по-долу. По този начин можем да доставим само липсващи компоненти от кованата. Ако установите някакви други проблеми, свържете се директно с фирмата или мебелната компания, от която сте закупили стоката.

**NL** Onze direct dienst de voor onze onderdelen  
 Wanneer er een onderdeel ontbreekt, kunt u deze servicekaart direct aan onze Nederlandse e-mailadres sturen. Wij kunnen langzamerhand wel achter alle benodigde onderdelen. Mocht u een ander probleem met uw meubel hebben, verzekerden wij u contact op te nemen met uw meubeldealer.

**PL** Nasza bezpośrednia usługa, części montażowych  
 Jeżeli brakuje części kowanych do montażu, prosimy o przesłanie nam niżej (zajętej karty serwisowej) na adres, podany niżej e-mailem. W ten sposób możemy przesyłać. Poniżej tylko brakujące części. W przypadku innych reklamacji dotyczących mebla, prosimy zgłaszać się bezpośrednio do sklepu, w którym został dokonany zakup.

**HR** Servis za dijelove  
 U slučaju da nedostaje neki od dijelova molimo vas da nas obavijestite e-mailom na adresu navedenu ovdje. Na ovaj način možemo dostaviti samo dijelove. U slučaju da imate bilo kakve druge probleme vezane uz lemljeni namještaj molimo vas da se obratite izravno trgovini namještaja gdje je isti kupljen.

**HU** Közvetlen szolgáltatás kovácsolt alkatrészekre  
 Ha hiányzik egy csavar, szelvény, kovácsolt alkatrészt az alábbi e-mail címre. Azonban csak a hiányzó alkatrészt tudunk így küldeni. Amennyiben másféle probléma merül fel, forduljon közvetlenül a bolti kereskedőre.

**SK** Naše přímé služby pro díly kování  
 Ak by Vám chýbala nejaká časť kování, môžete prostredníctvom služby priamo na nižšie uvedenú adresu. Týmto spôsobom však môžeme poslať iba chýbajúce diely. Ak by ste mali iný problém, obráťte sa priamo na Vašu predajňu nábytku.

**SLO** Naše direktno uslugo za montažne delce  
 Če vam manjka kakšno delce, lahko to storimo kar direktno po e-pošti na spodnjo e-mailno naslovno mesto. Tako lahko pošljemo samo delce. Če imate kakšno drugo težavo, se obrnite neposredno na vašo trgovino pohištva.

**RO** Serviciul nostru direct pentru ferramente  
 În cazul în care vă lipsește o piesă de fiermecerie puteți să trimiteți direct această card de service prin e-mail la adresa de mai jos. Noi nu putem să trimitem decât piesele de fiermecerie prin acest mod de comunicare.  
 Dacă aveți o altă reclamație referitoare la piesa de mobilier, atunci vă rugăm să vă adresați direct la magazinul dvs. de mobilier.

**RUS** Прямая директная услуга поставки фурнитуры  
 Если отсутствует какая-либо деталь из металла, пожалуйста, заполнить эту форму и отправить сервисную карту по адресу, указанному ниже. Однако, только отсутствующие детали мы можем доставить только этим способом. Если у вас есть другая претензия относительно приобретенного предмета мебели, пожалуйста, обратиться непосредственно к организатору, осуществляющему продажу.

**S** Vše direktno za kováčské diely  
 Om du mangar en beslag eller en del af kovácsolt delar, kan du skicka detta servicekort direkt till e-postadressen som anges nedan. Tänk på att vi endast kan skicka de saknade beslag eller delarna på detta sätt. Om du vill ha hjälp med andra frågor, kontakta ditt möbelförhandlingsställe.

**ES** Nuestro servicio directo para el montaje  
 Si le falta algún accesorio, puede enviar esta tarjeta de servicio directamente a la siguiente dirección. No obstante, por este método solo podemos enviar accesorios. Si tiene alguna otra objeción sobre su mueble, consulte directamente con su mueblero.

**TR** Doğrudan teslimat hizmeti  
 Bir demir aksesuar veya parça eksikse, lütfen aşağıdaki adresi kullanarak doğrudan e-posta yoluyla bildirmenizi rica ederiz. Bu şekilde sadece demir aksesuarları gönderebiliriz. Mobilyanızla ilgili diğer problemler için lütfen doğrudan mobilya satıcınıza danışın.

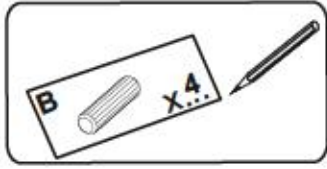

# RAVENNA 55

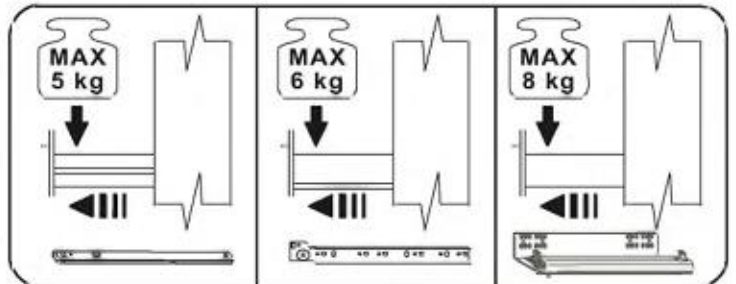
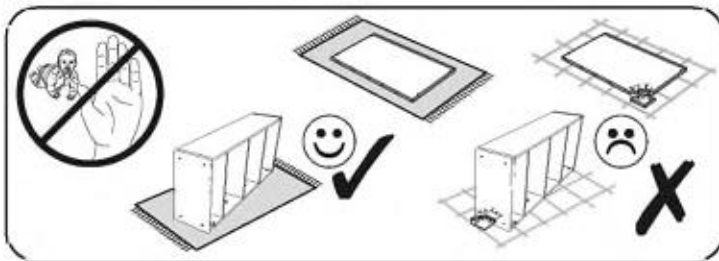
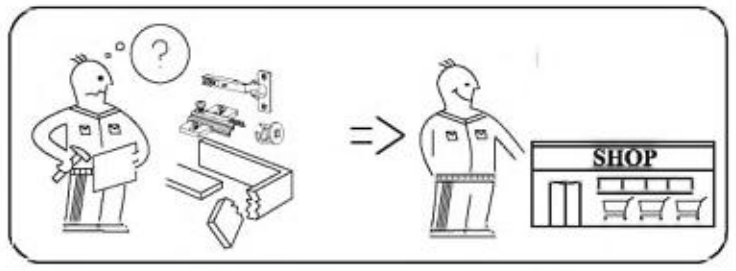
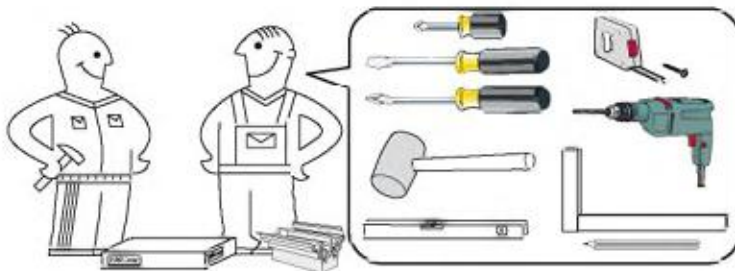
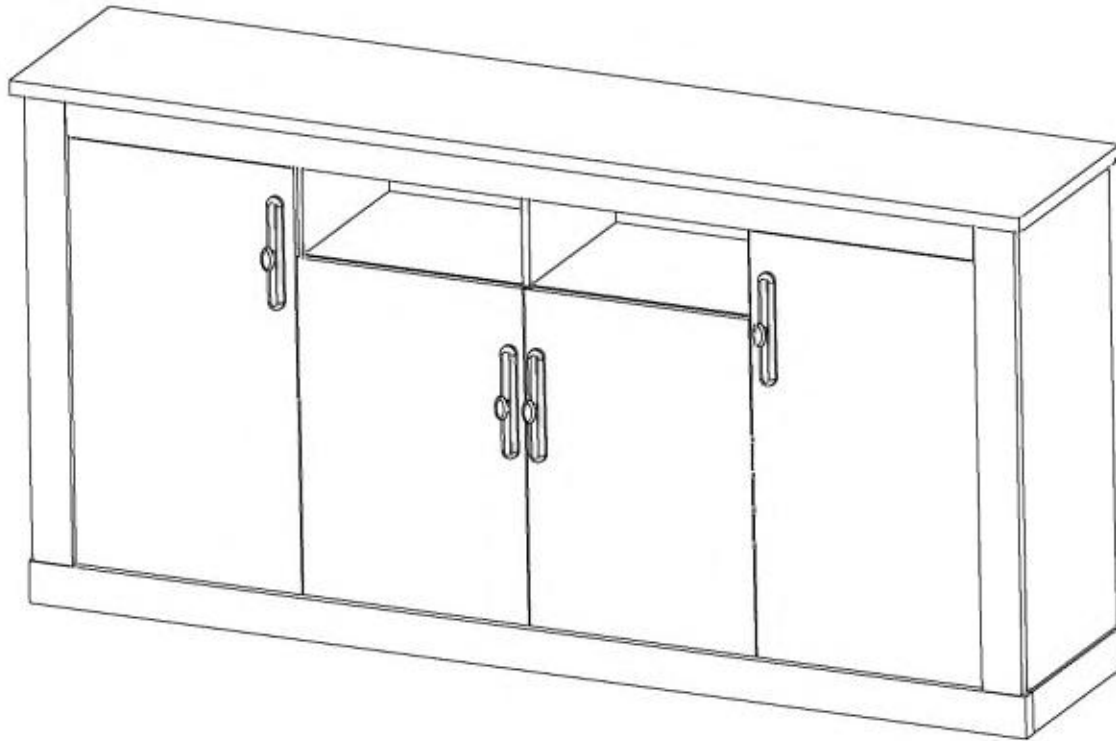
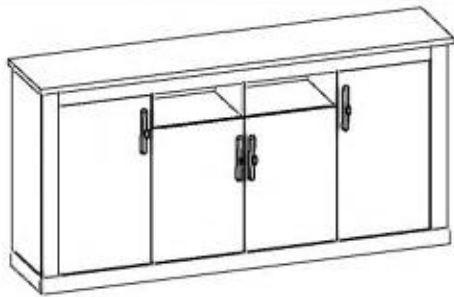

# RAVENNA 55

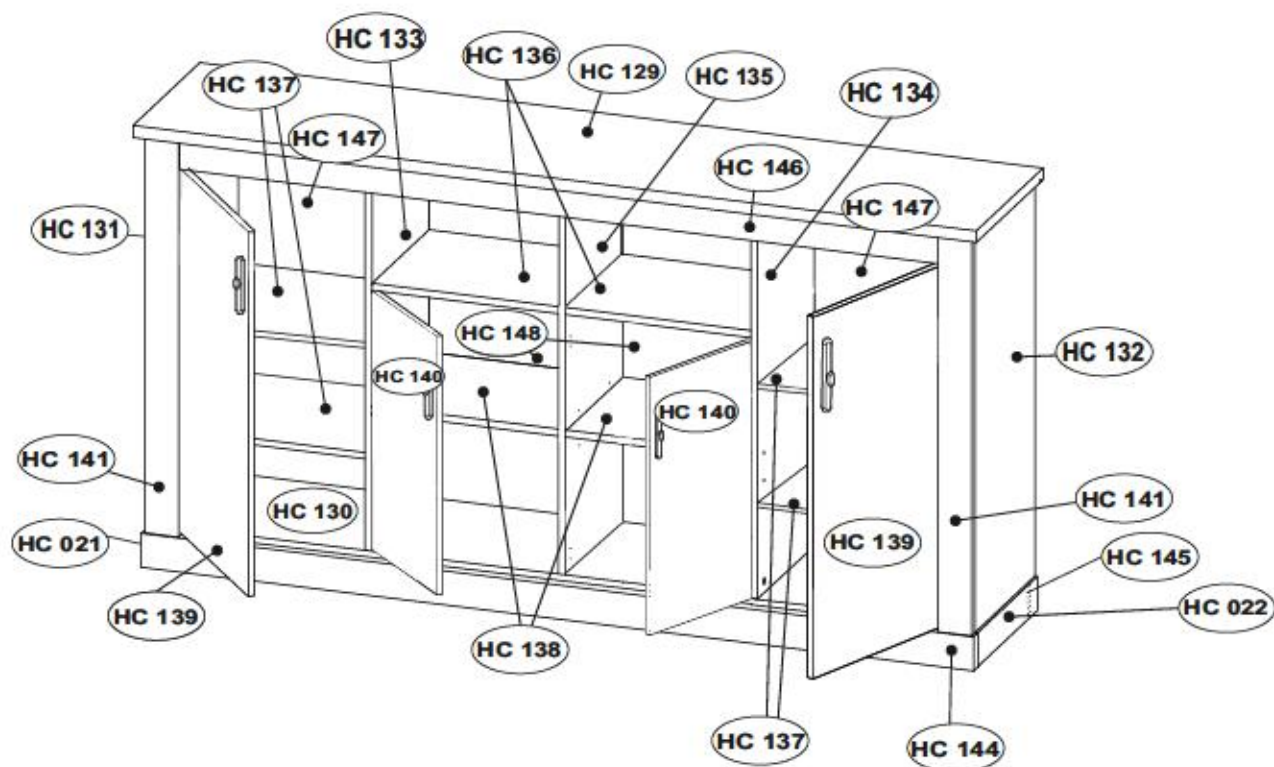

max.

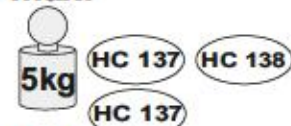

max.

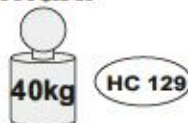

AI No.	Qty	H	W	D	PKG
HC 021	x1	386	80	28	1/2
HC 022	x1	386	80	28	1/2
HC 129	x1	2003	431	28	2/2
HC 130	x1	1931	369	15	2/2
HC 131	x1	894	389	15	1/2
HC 132	x1	894	389	15	1/2
HC 133	x1	879	368	15	2/2
HC 134	x1	879	368	15	2/2
HC 135	x1	879	368	15	2/2
HC 136	x2	435	367	15	2/2
HC 137	x4	507	360	15	1/2
HC 138	x2	434	360	15	1/2
HC 139	x2	814	447	15	1/2
HC 140	x2	644	447	15	1/2
HC 141	x2	894	80	22	1/2
HC 144	x2	1976	80	28	2/2
HC 145	x1	1918	80	28	2/2

AI No.	Qty	H	W	D	PKG
HC 146	x1	1803	74	18	2/2
HC 147	x2	899	521	2,5	1/2
HC 148	x2	899	449	2,5	1/2



# RAVENNA 55

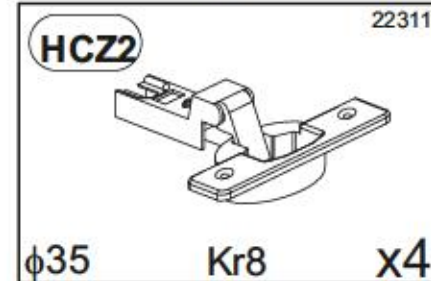
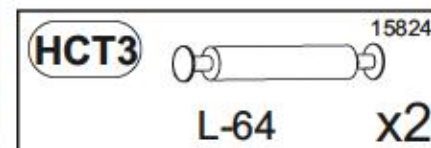
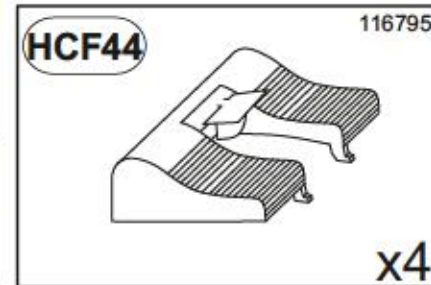
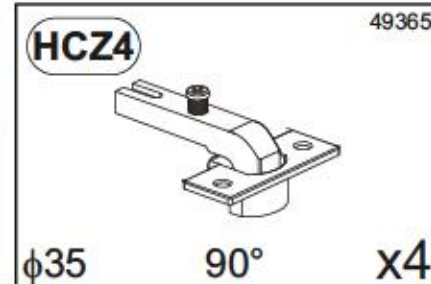
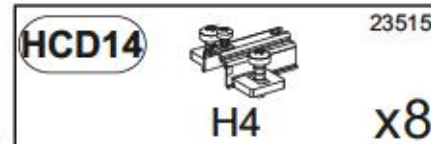
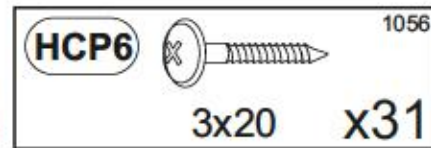
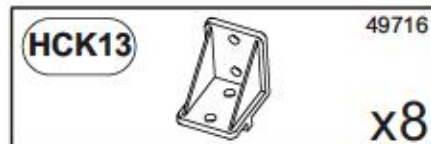
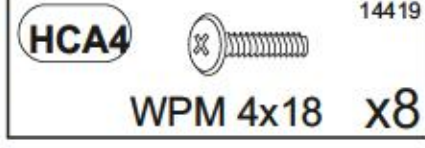
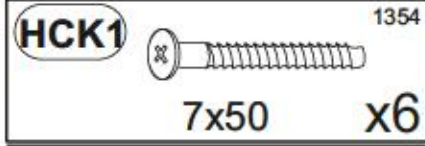
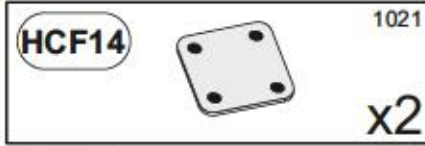
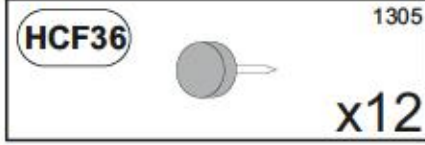
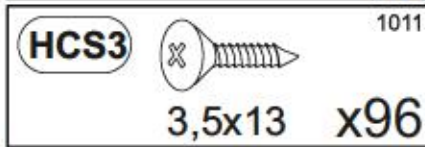
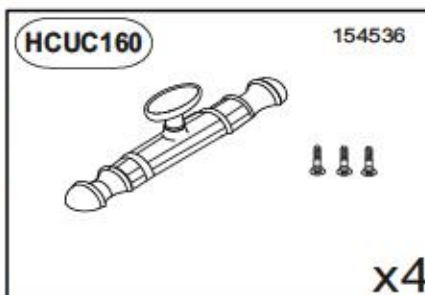
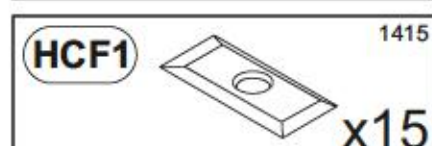
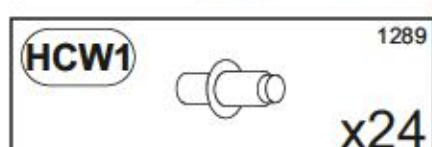
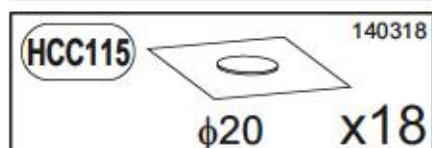
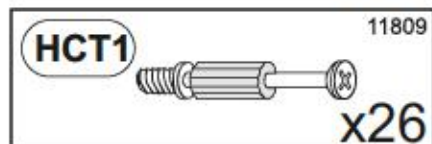
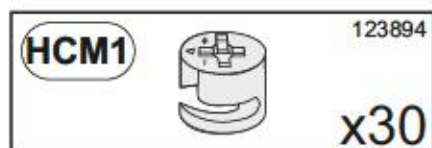
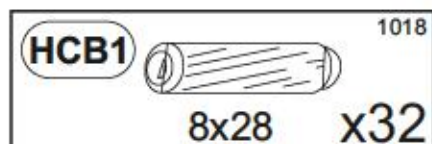

# 1

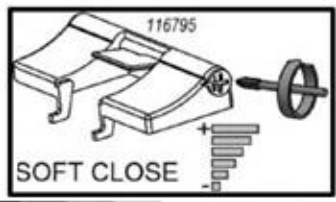
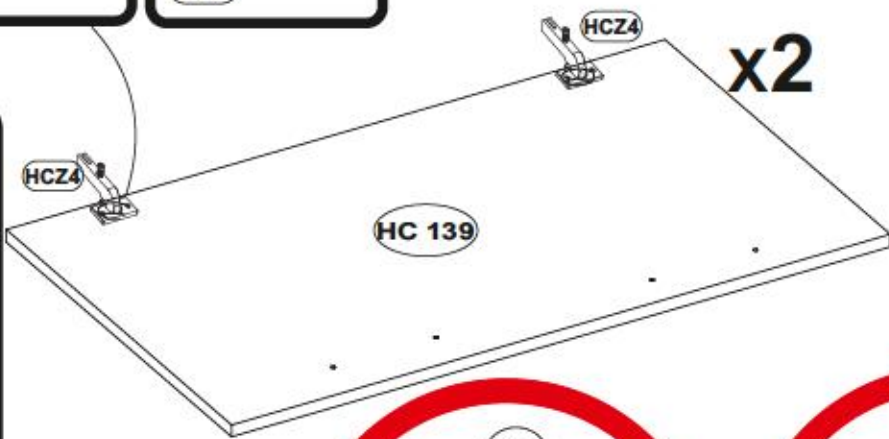
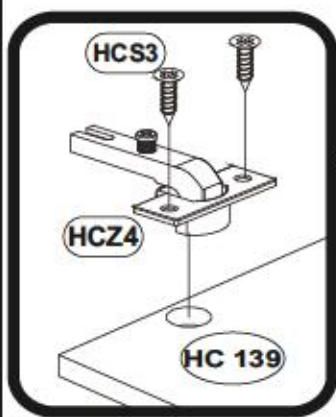
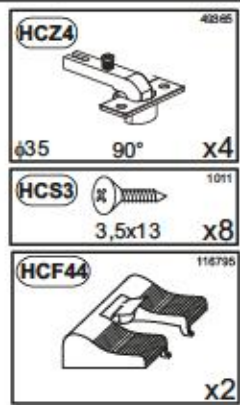
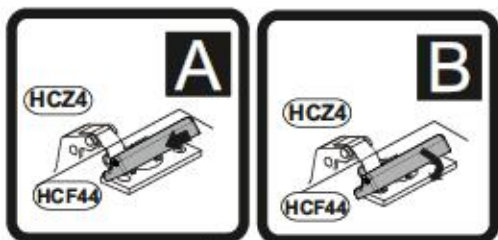

# 2

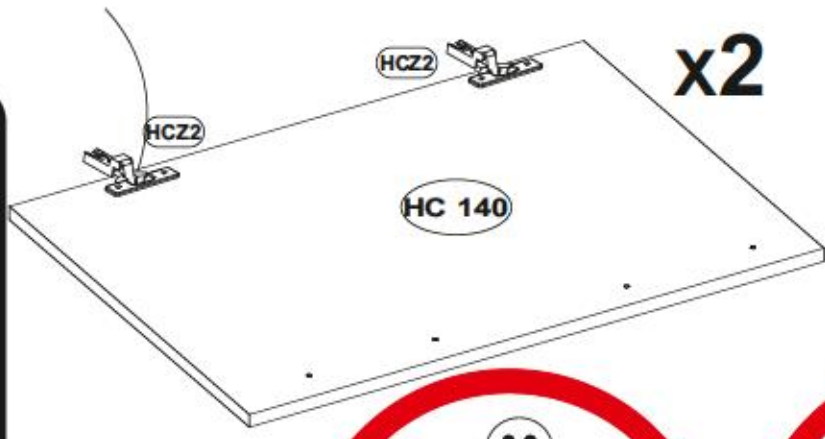
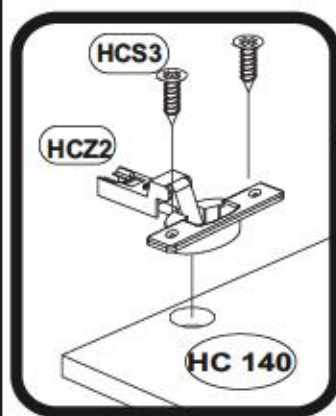
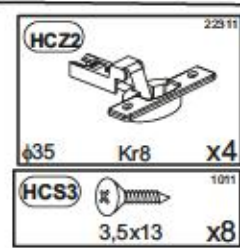



3

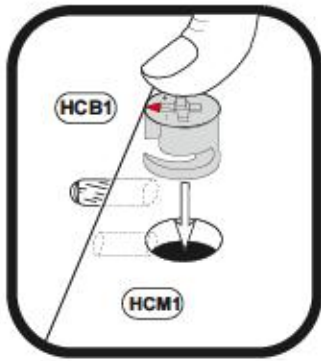

HCB1		1018
	8x28	x4
HCM1		12384
		x4
HCT1		11809
		x4

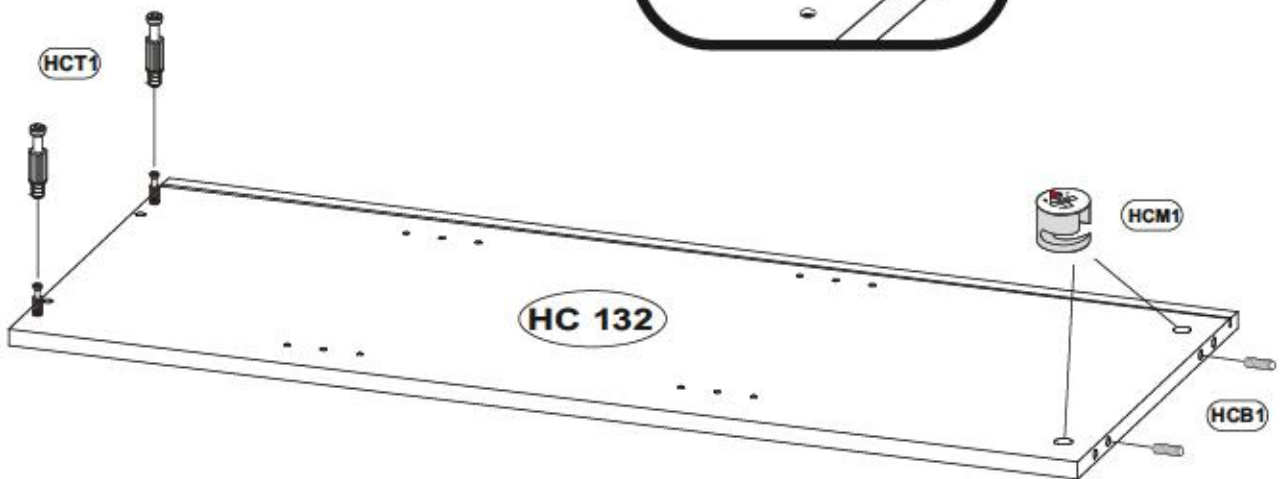
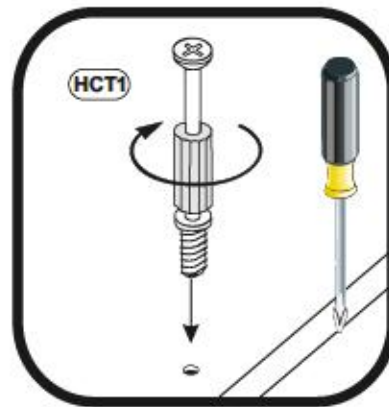
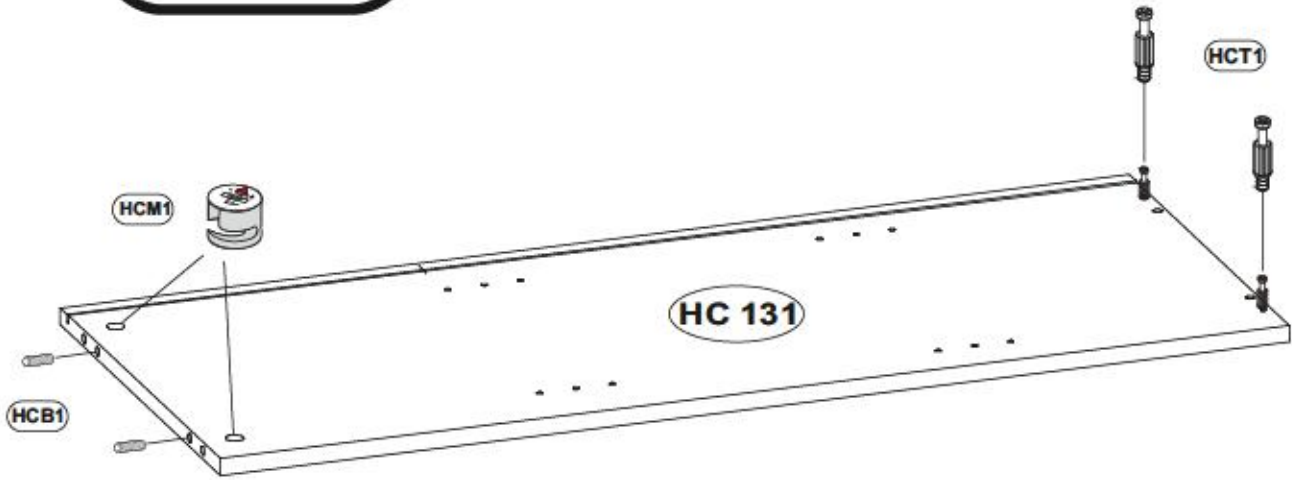

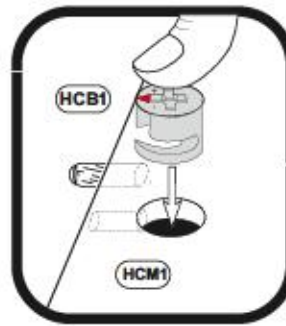
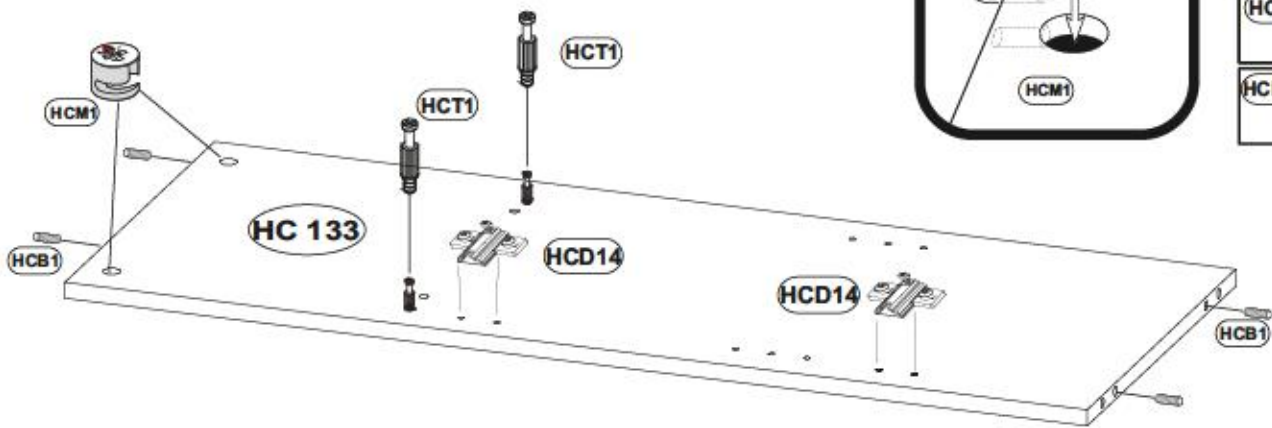

4

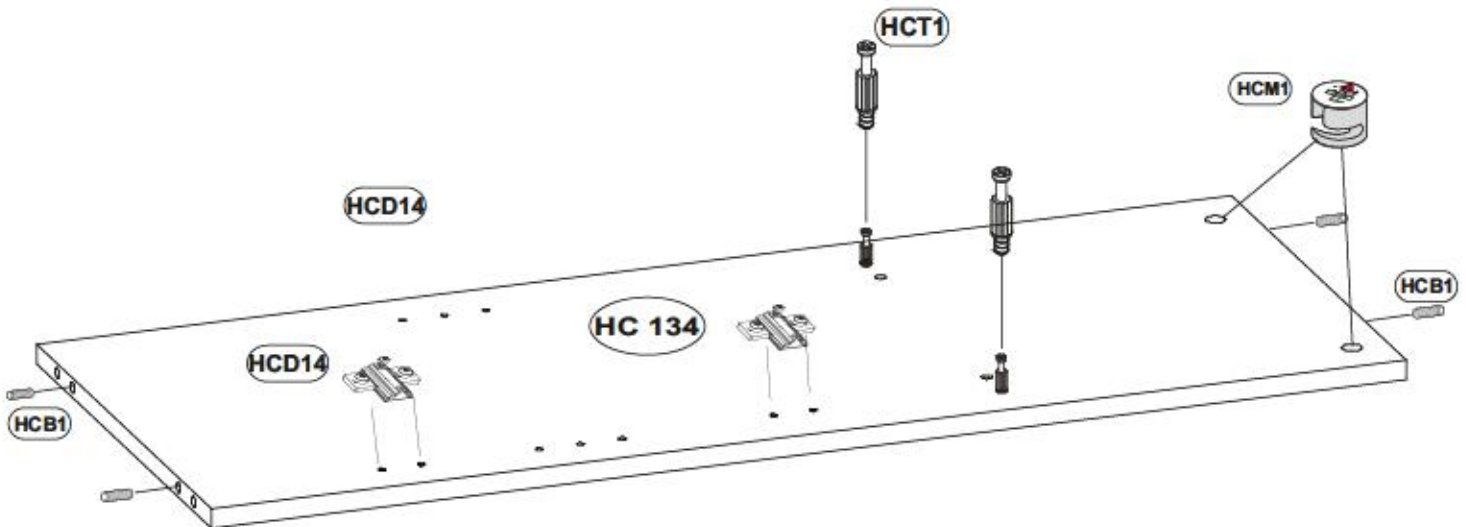
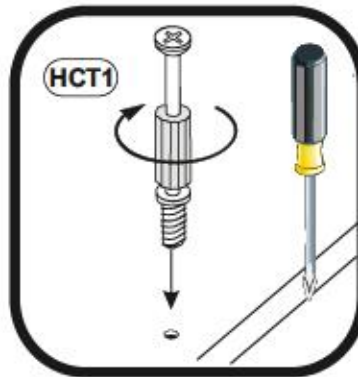
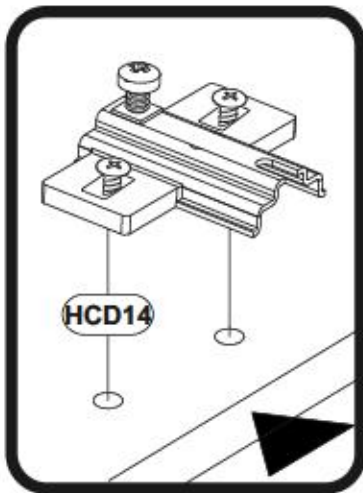

HCM1		123894	x4
HCB1		1018	x8
HCT1		11809	x4
HCD14		29515	x4



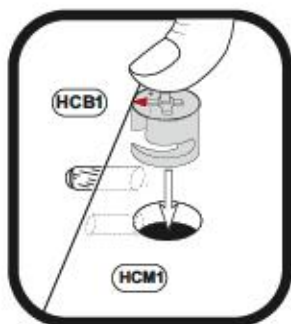
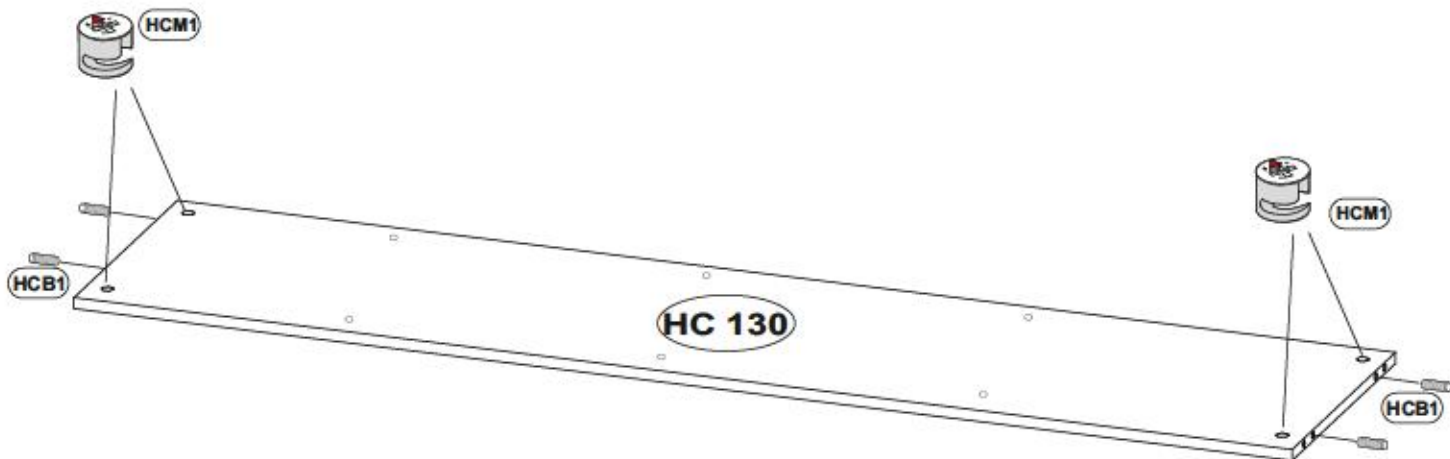

5

HCB1		1018
	8x28	x4
HCM1		123894
		x4



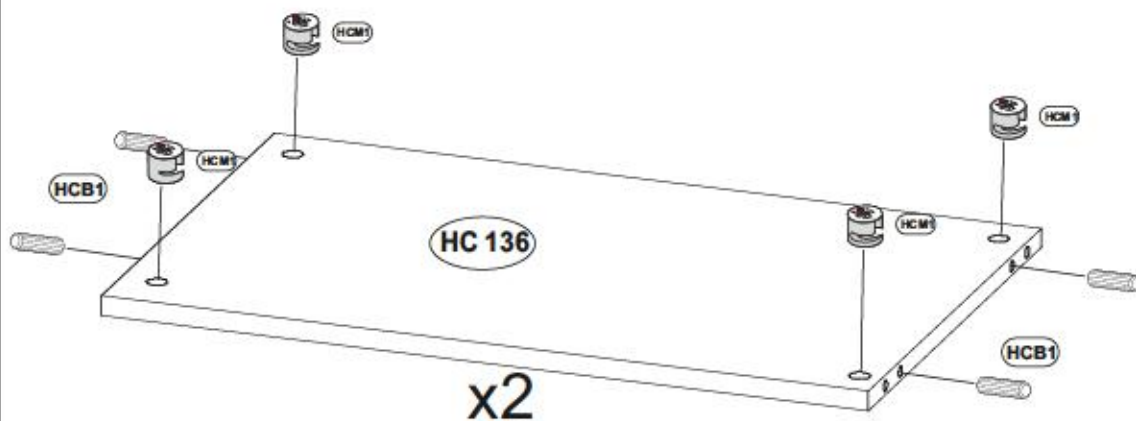

6

HCB1		1018
	8x28	x8
HCM1		123894
		x8



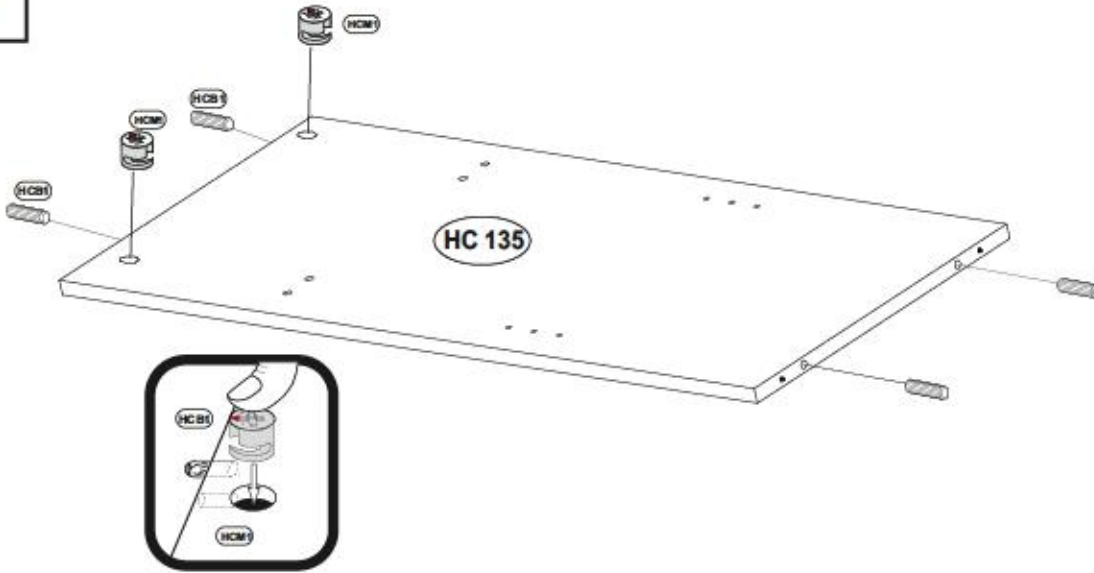



7

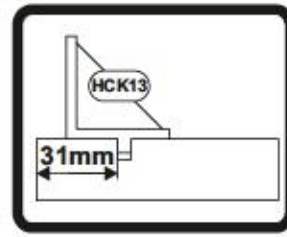
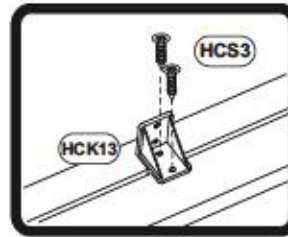
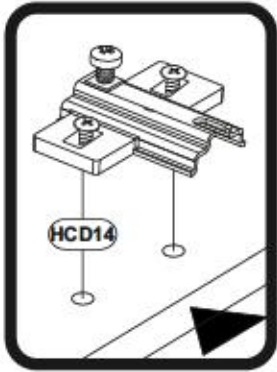

<b>HCB1</b>		10 18
	8x28	x4
<b>HCM1</b>		12 38 94
		x2

8



<b>HCK13</b>		234 92
		x8
<b>HCS3</b>		10 11
	3,5x13	x16
<b>HCD14</b>		29 61 5
	H4	x4

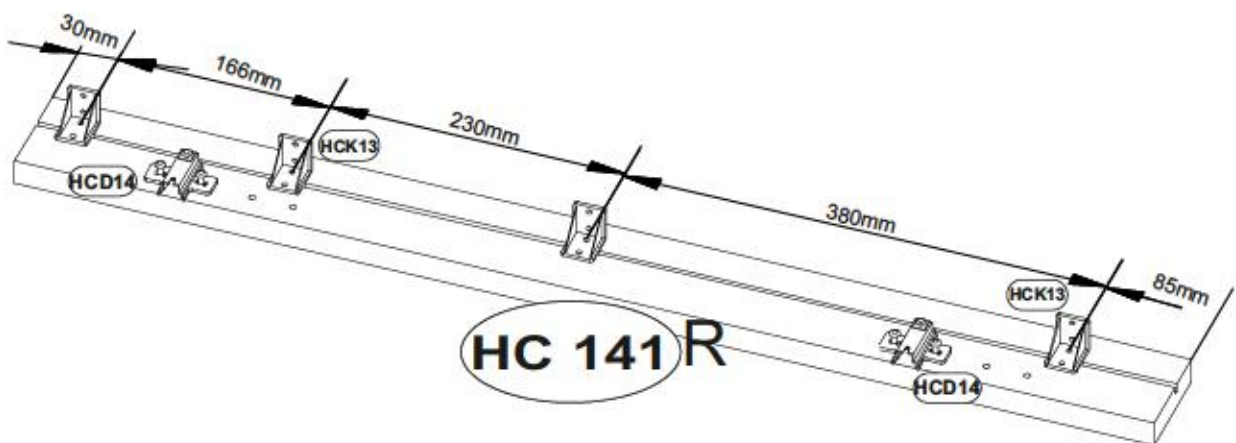
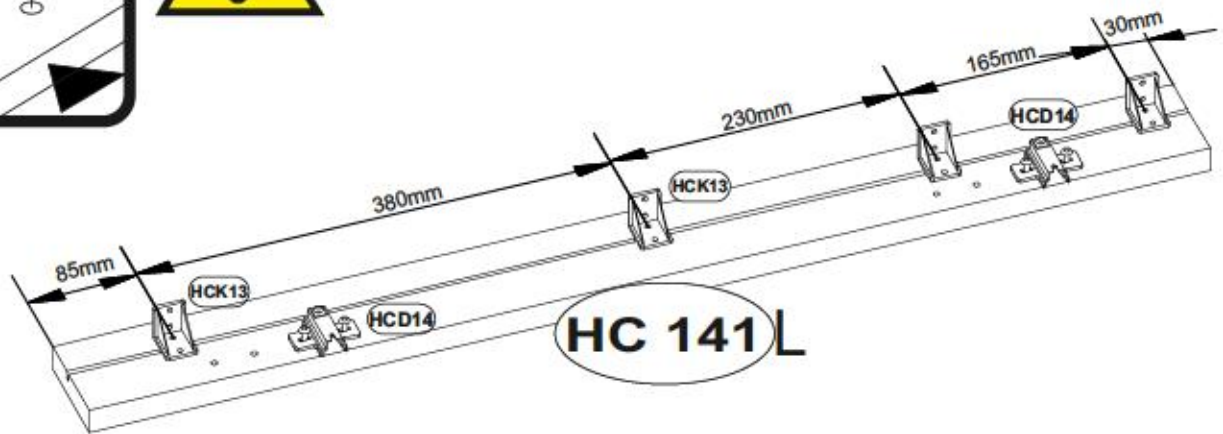

9

HCS3 1011  
3,5x13 x16

HCT1 1398  
x8

HCM1 123844  
x8

HCB1 1018  
8x28 x4

HCK15 81568  
x8

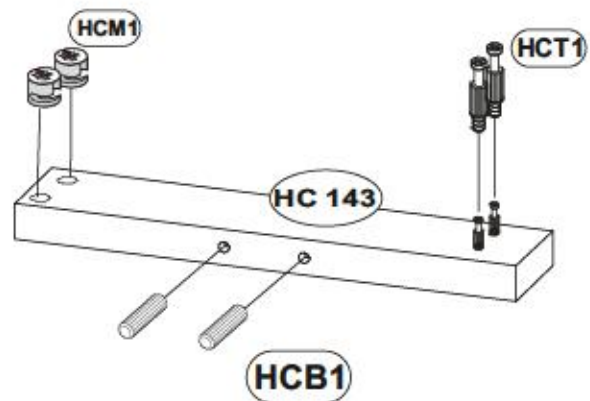
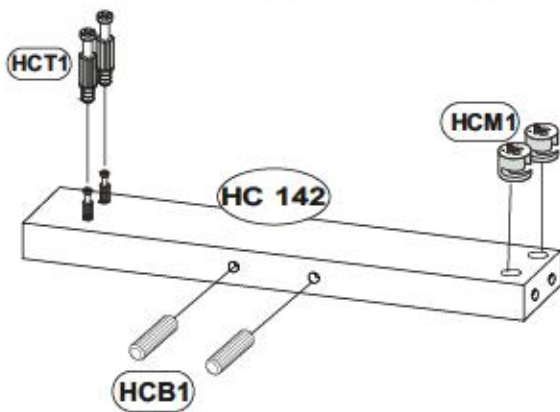
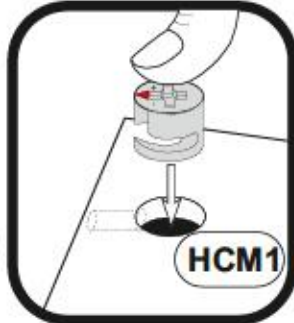
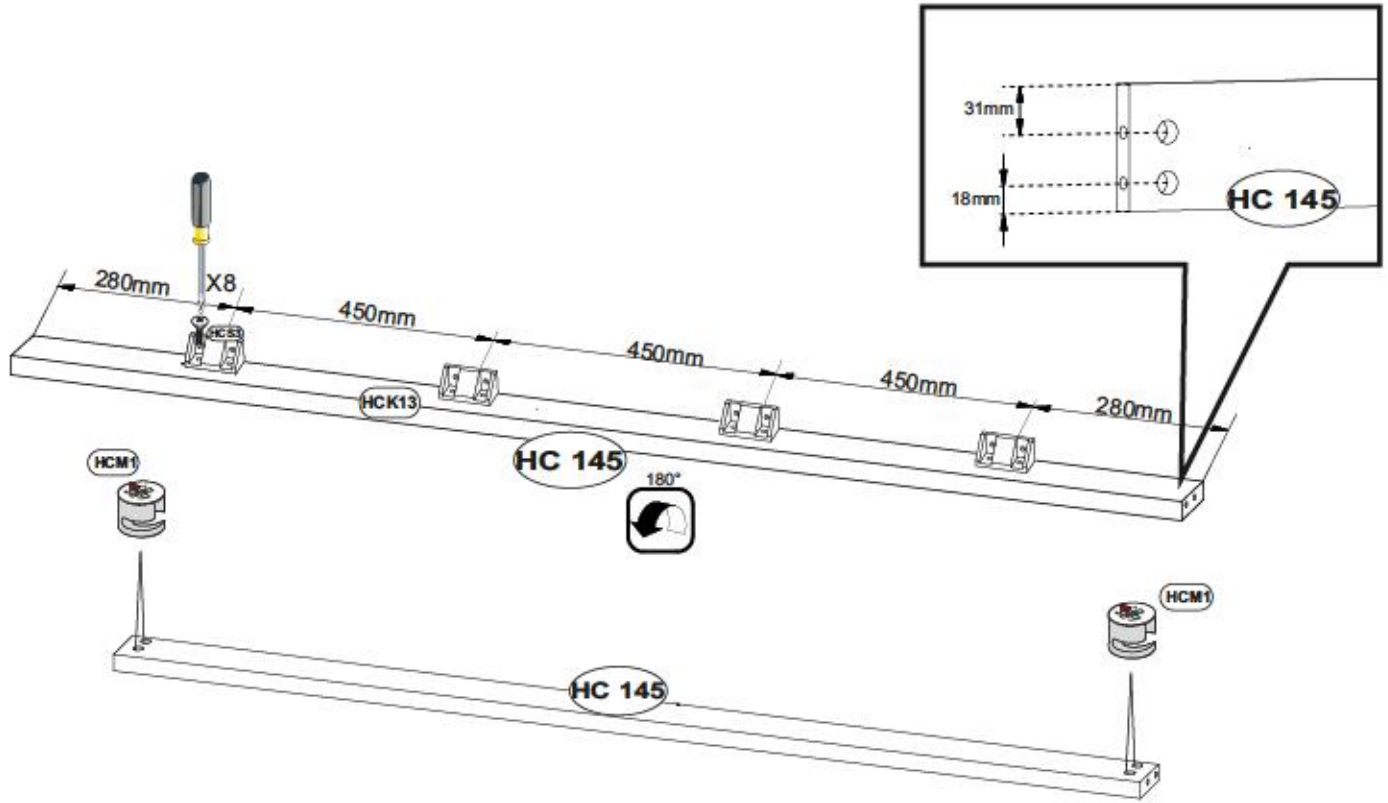
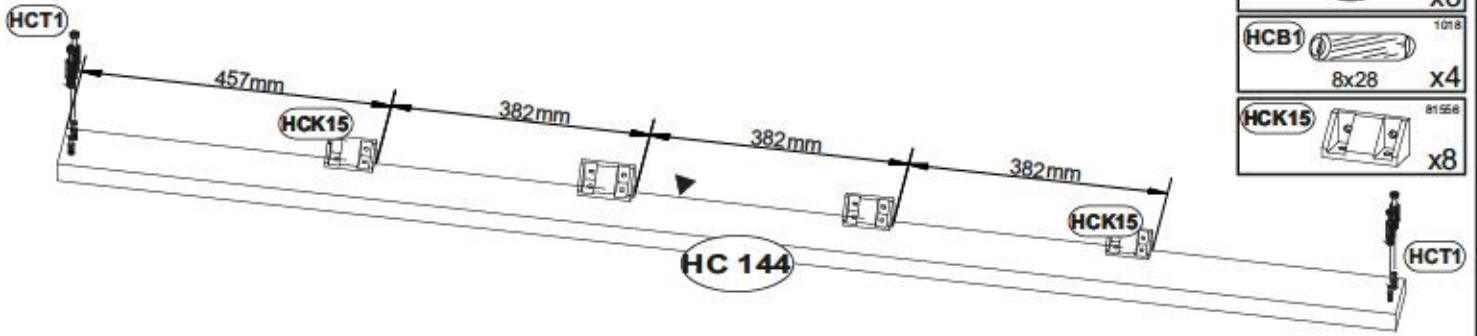



10

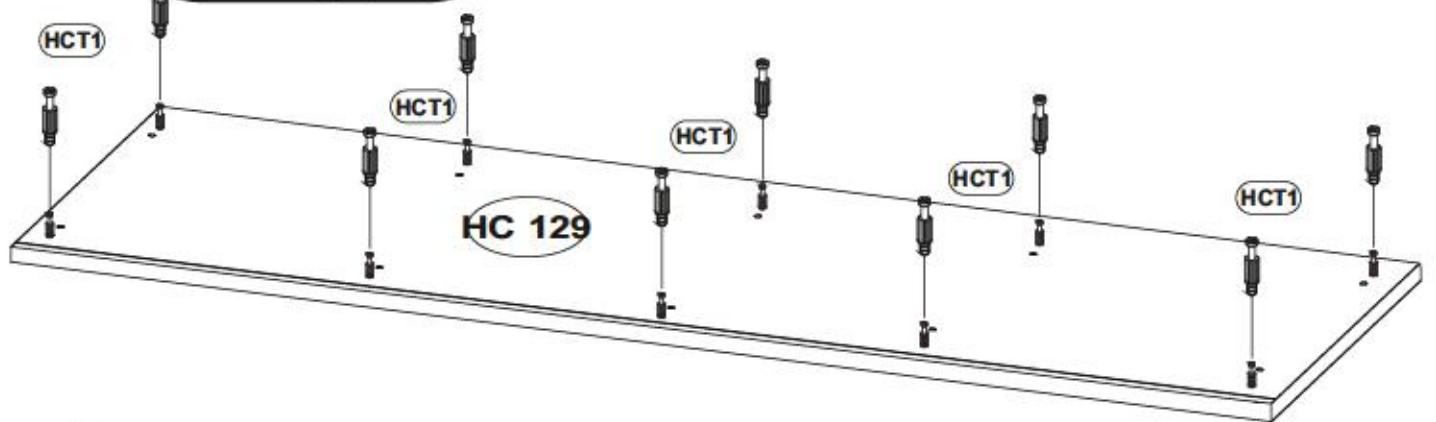
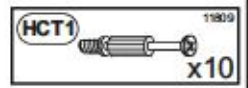
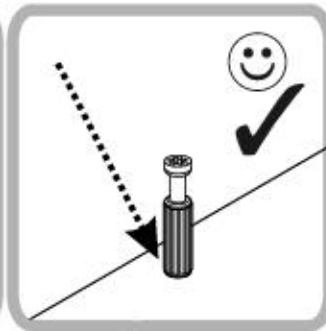
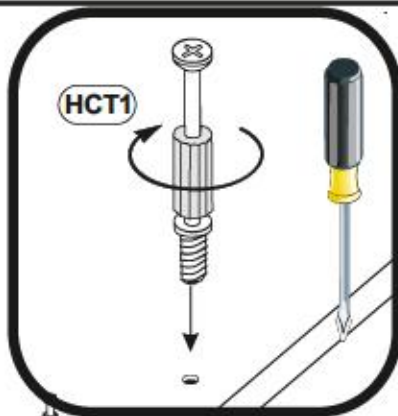

11

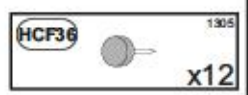
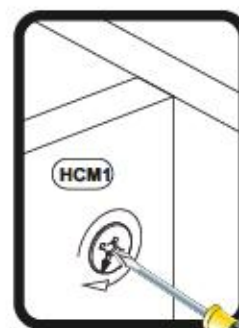
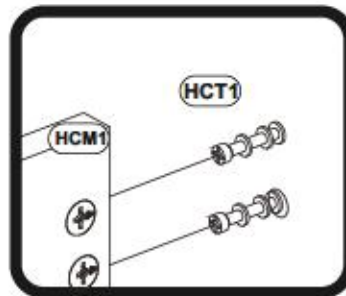

A

B

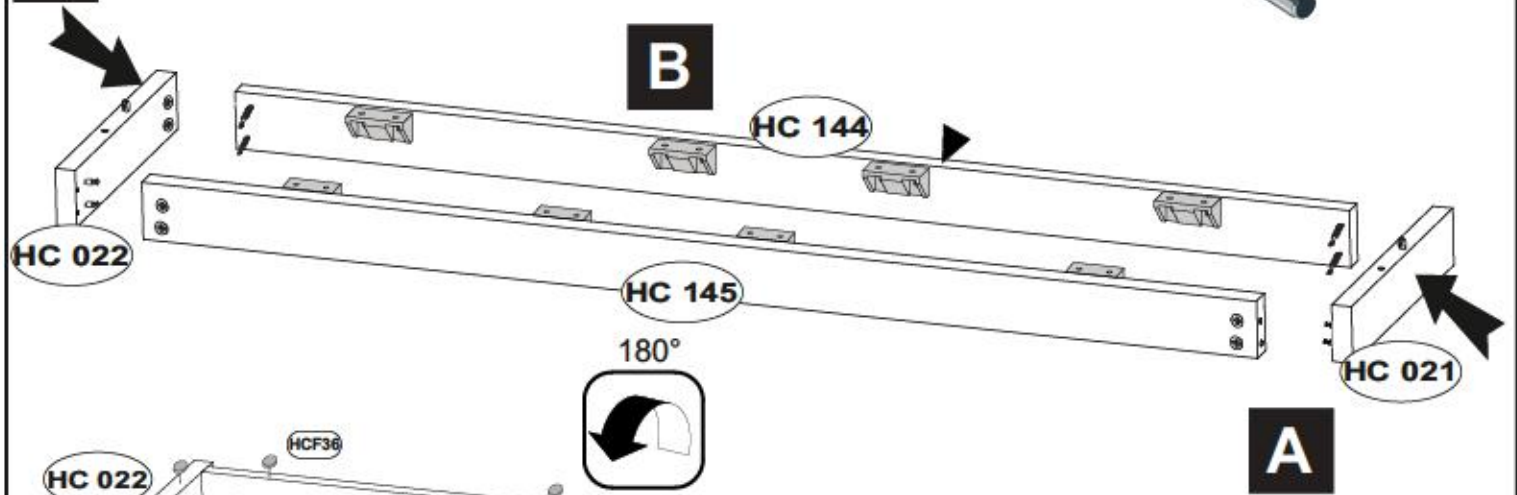

HC 022

HC 144

HC 145

180°

HC 021

A

HC 022

HC 145

HC 144

HC 021



12

HCT3 15824  
L-64 x2

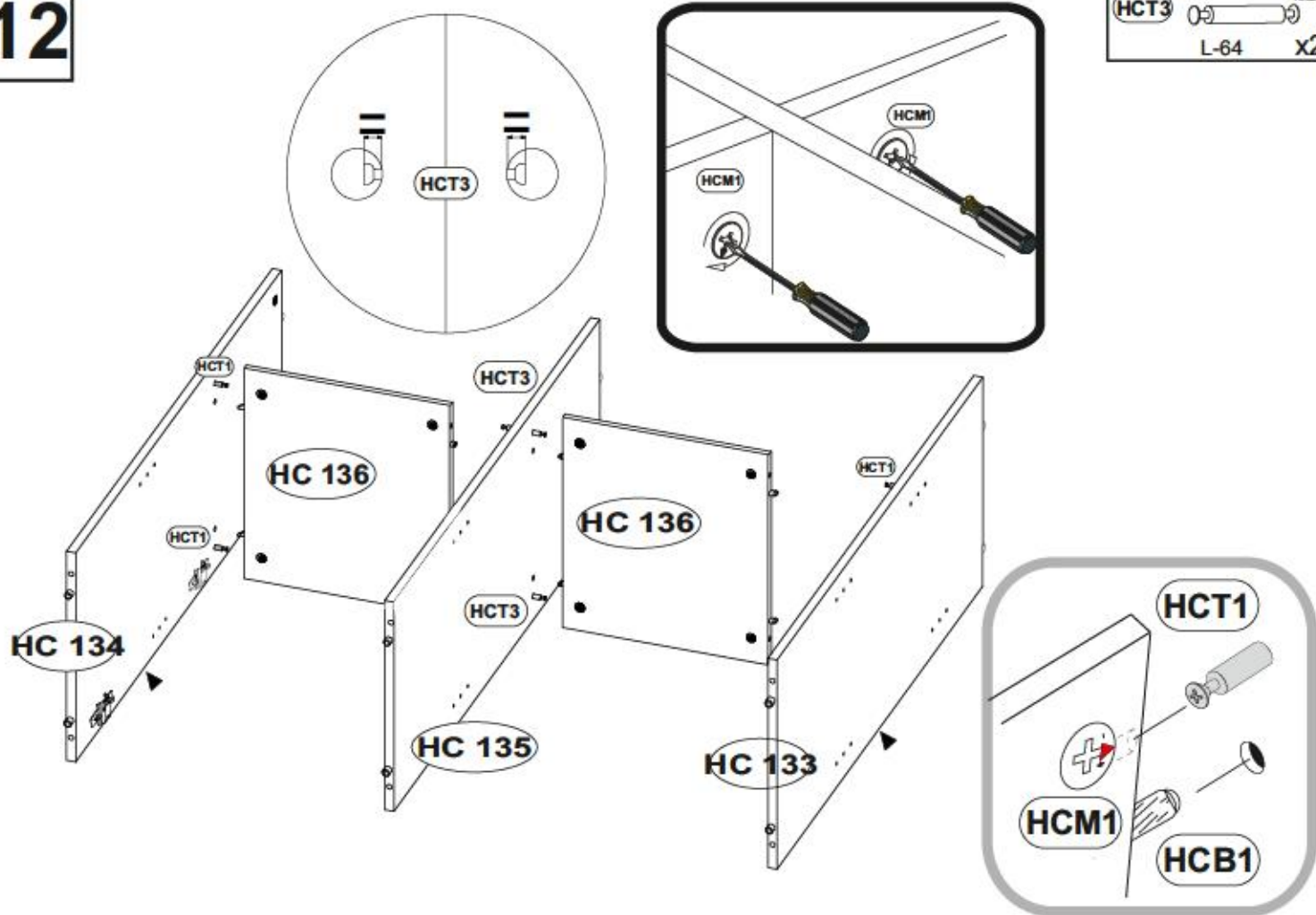

13

HCK1 1354  
7x50 x6

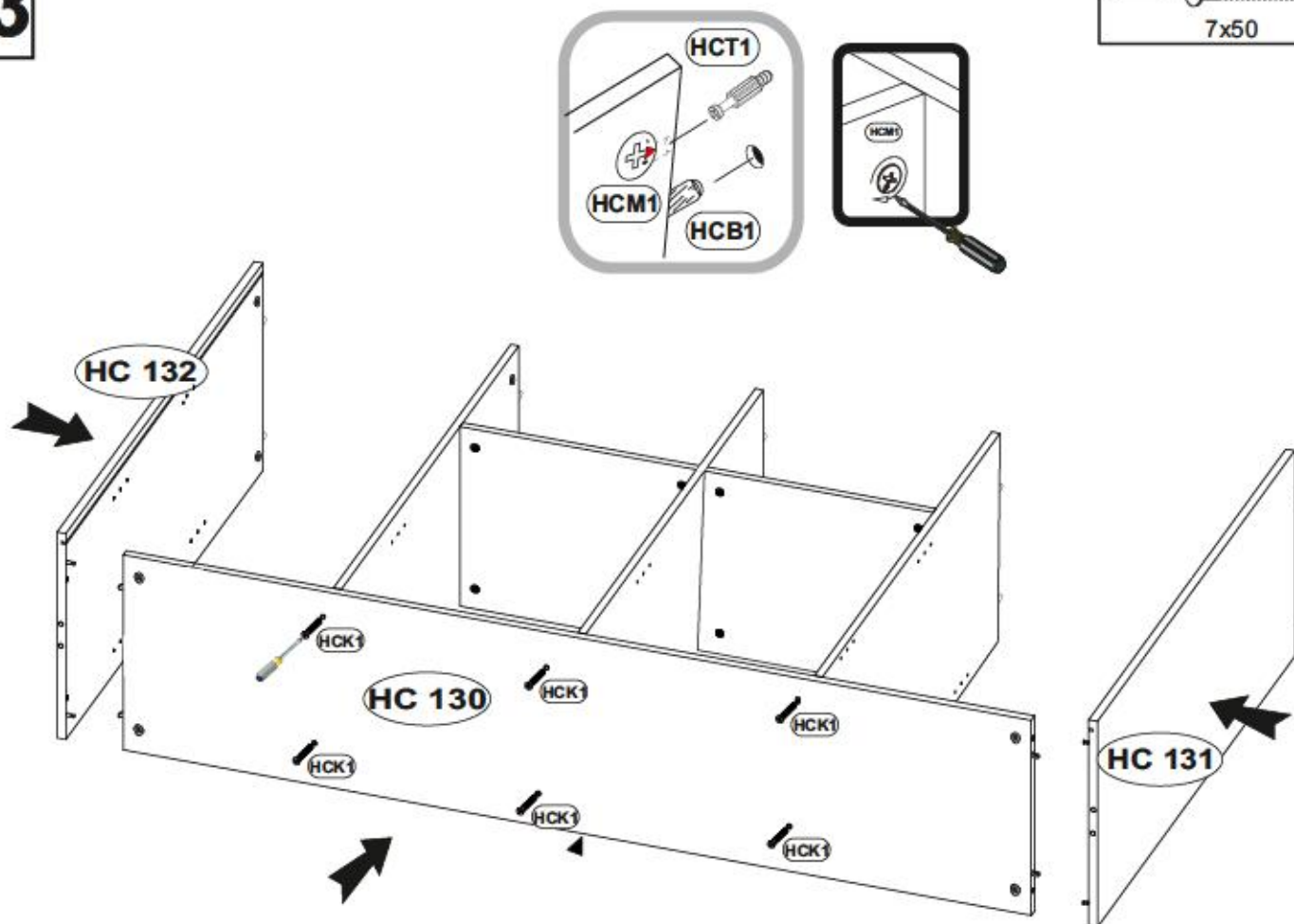

14

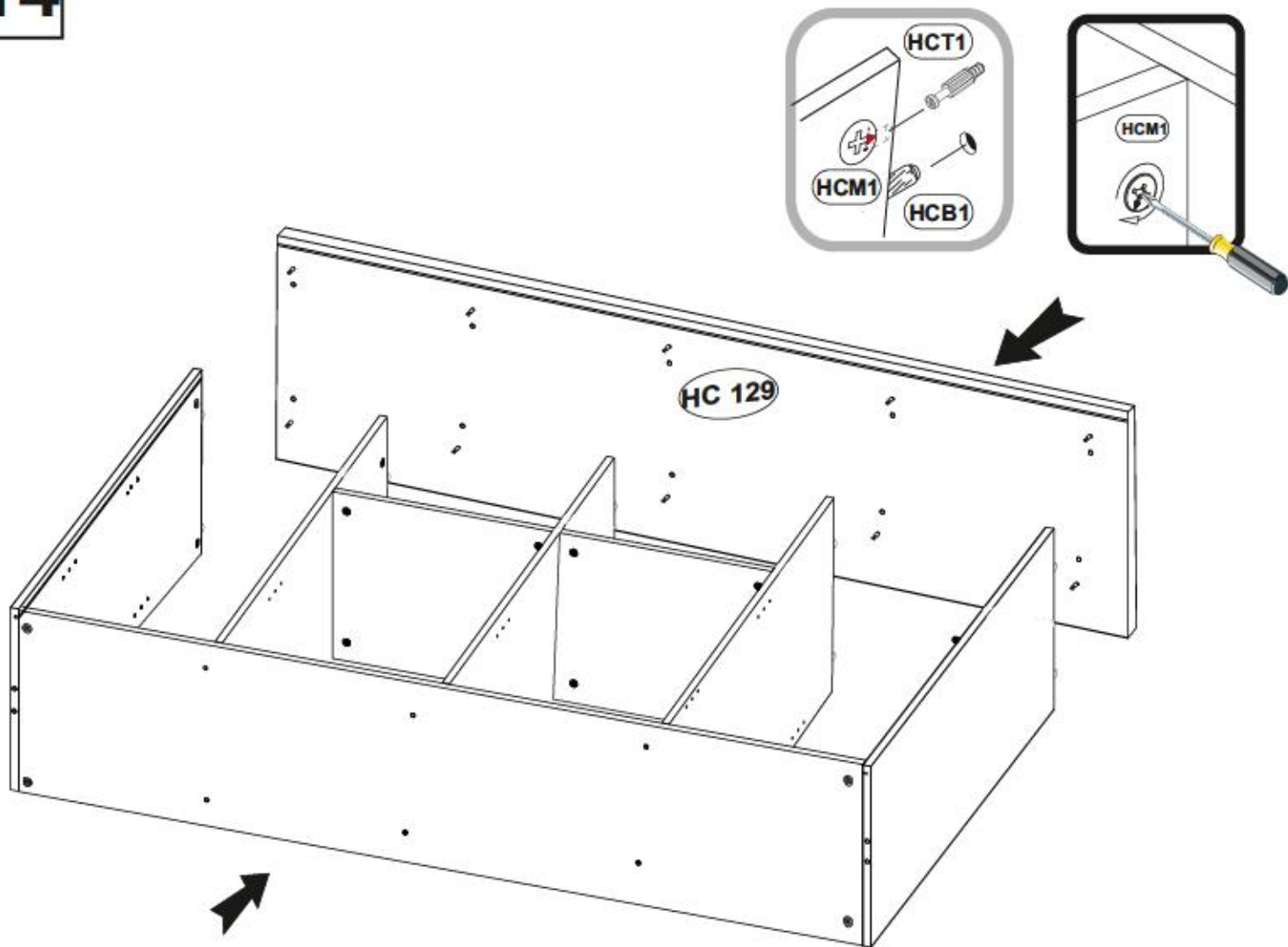

15

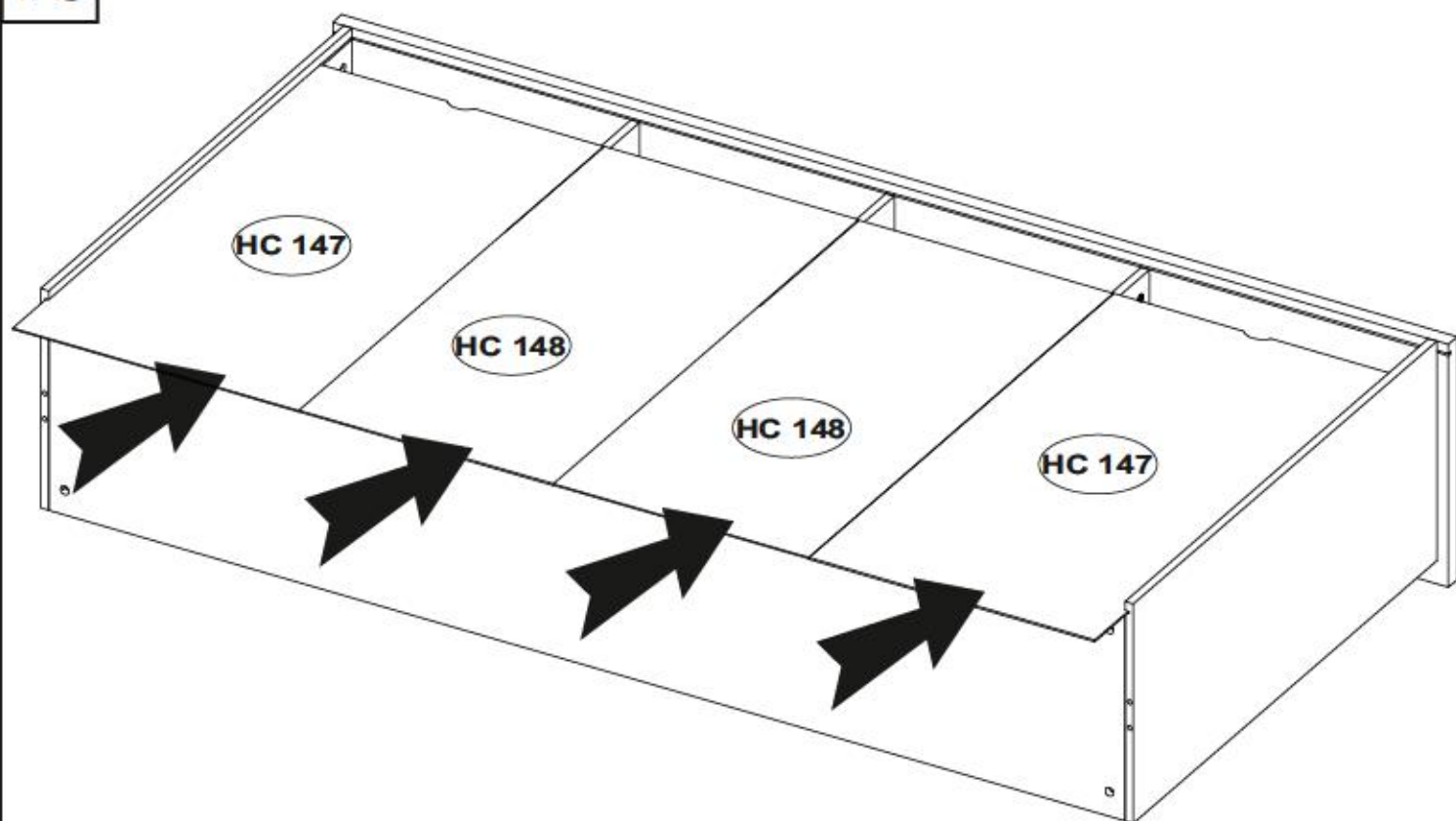





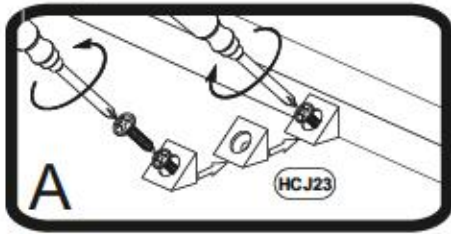

# 16

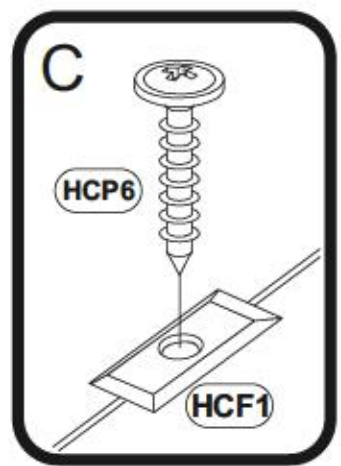
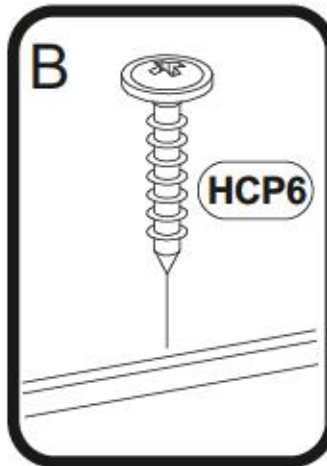
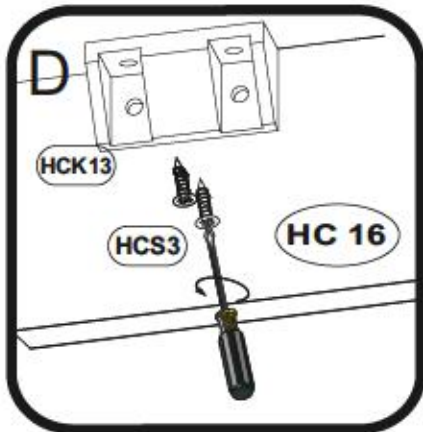
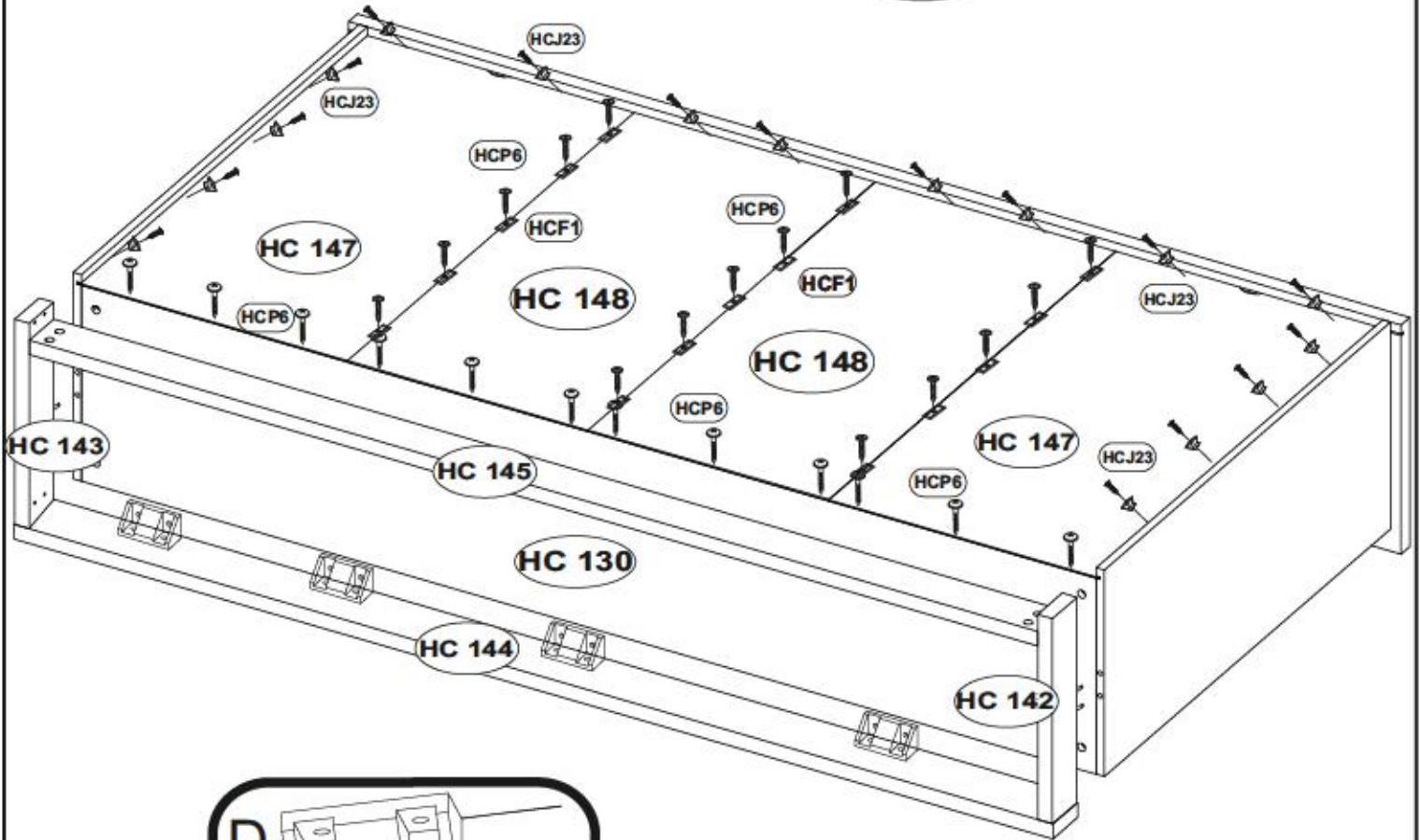

HCJ23		1302
		x16
HCP6		1096
		3x20 x27
HCF1		1415
		x15
HCS3		1011
		3,5x13 x16



HCF14		10.21
		x2
HCS3		10.11
	3,5x13	x32
HCK15		11.05.73
		x2

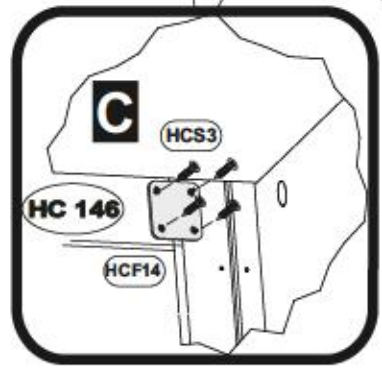
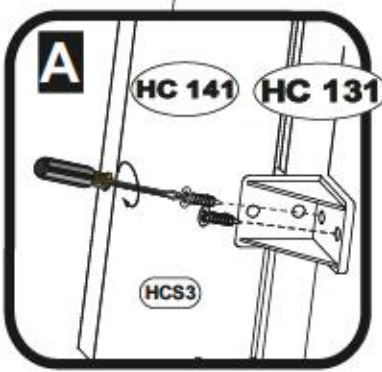
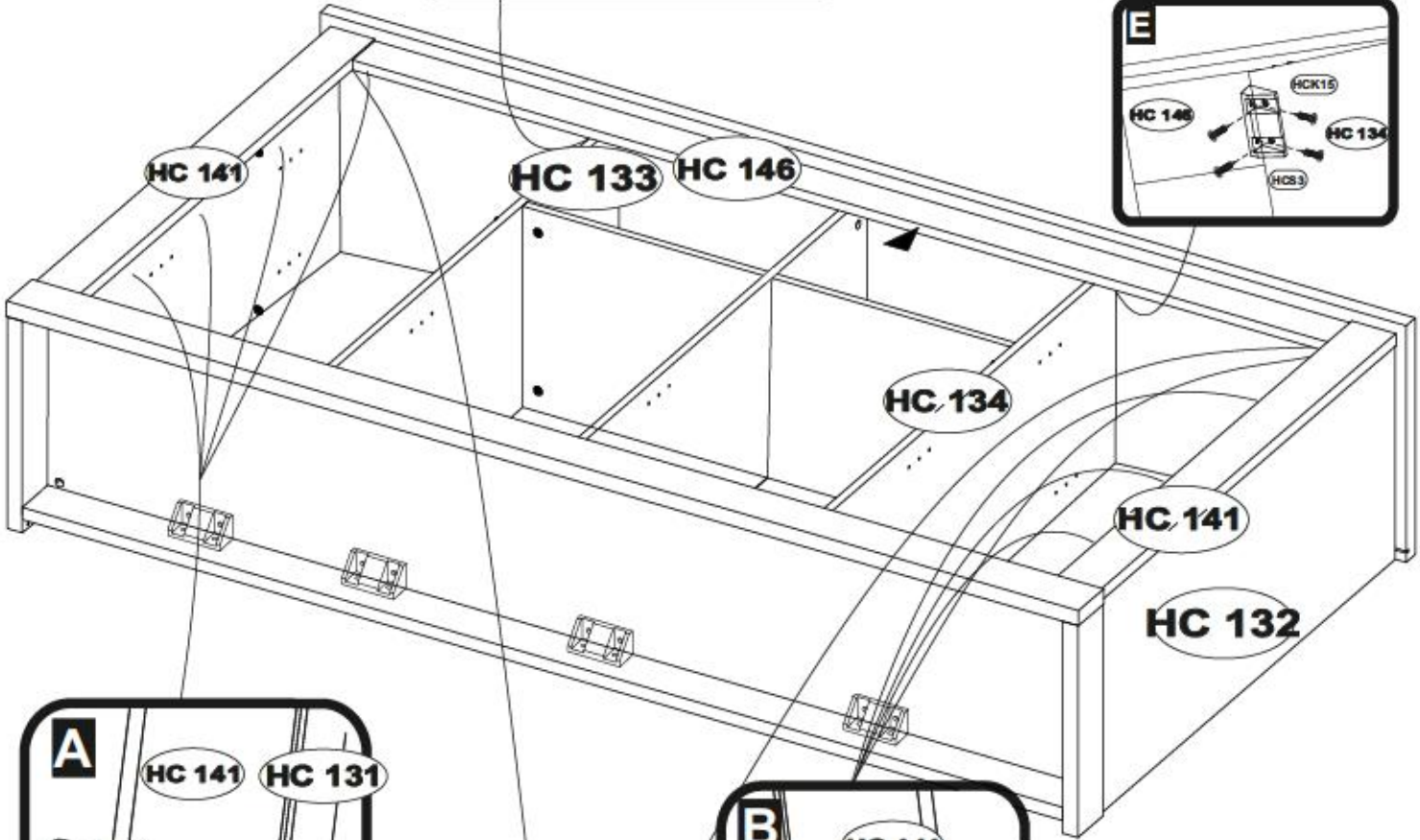
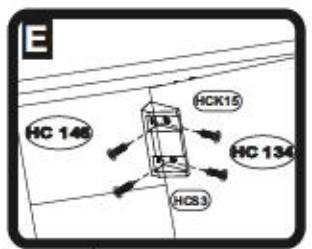
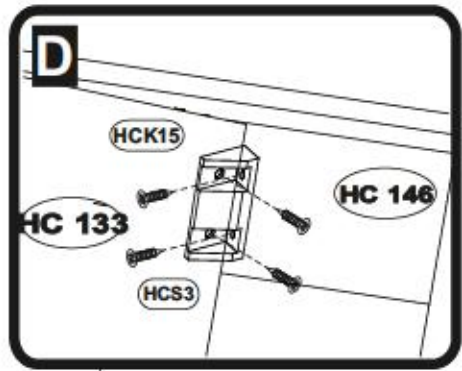



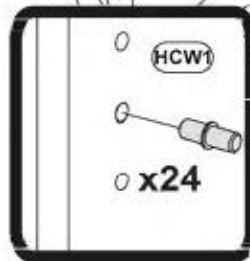
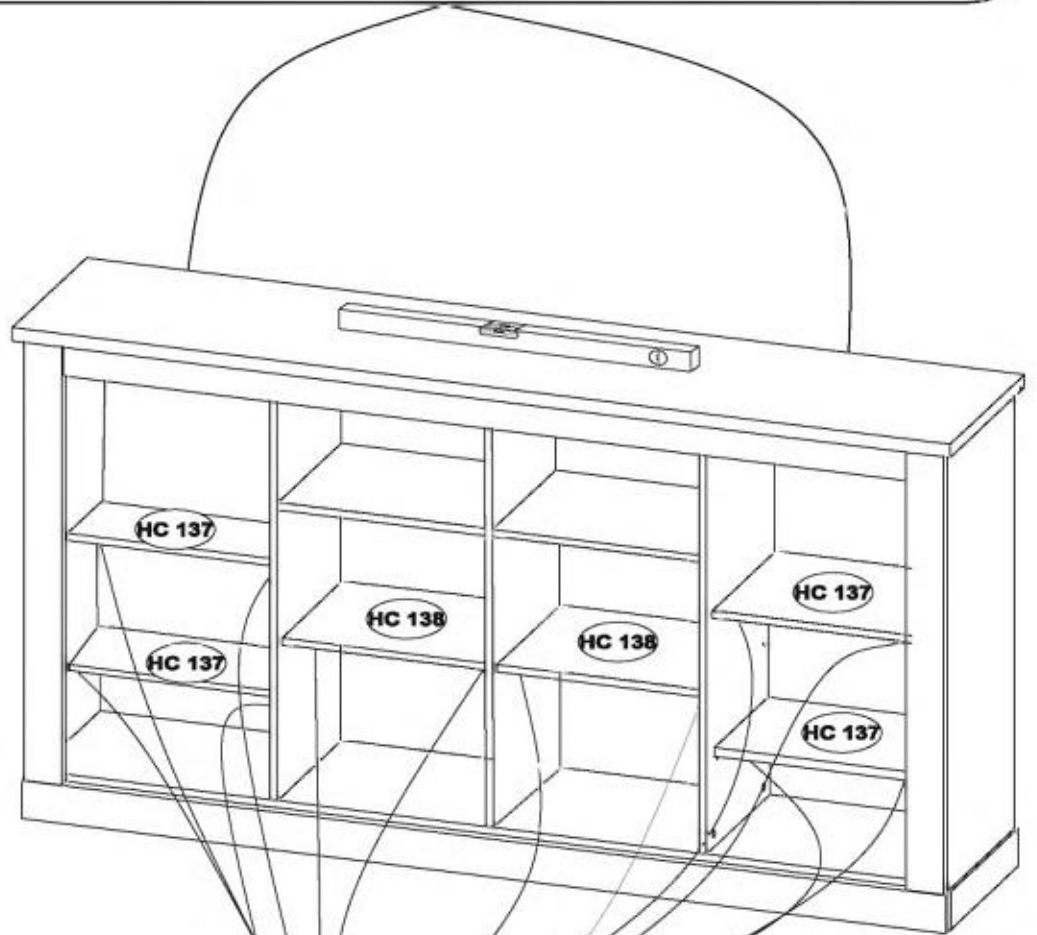
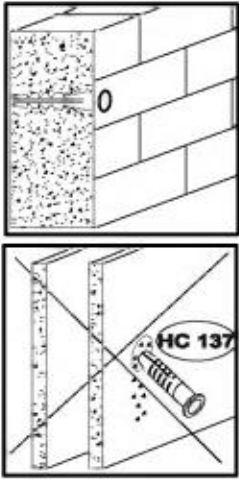
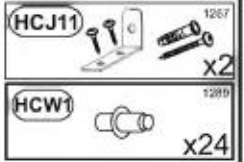

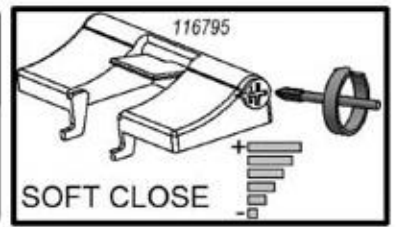
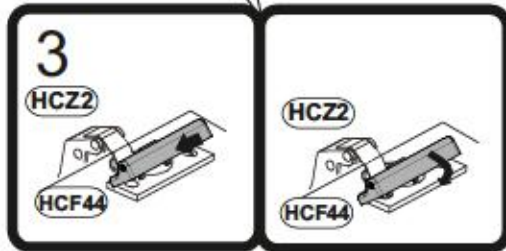
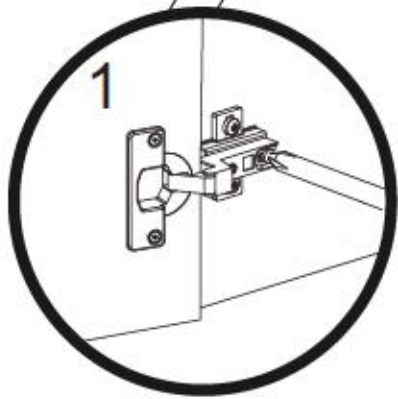
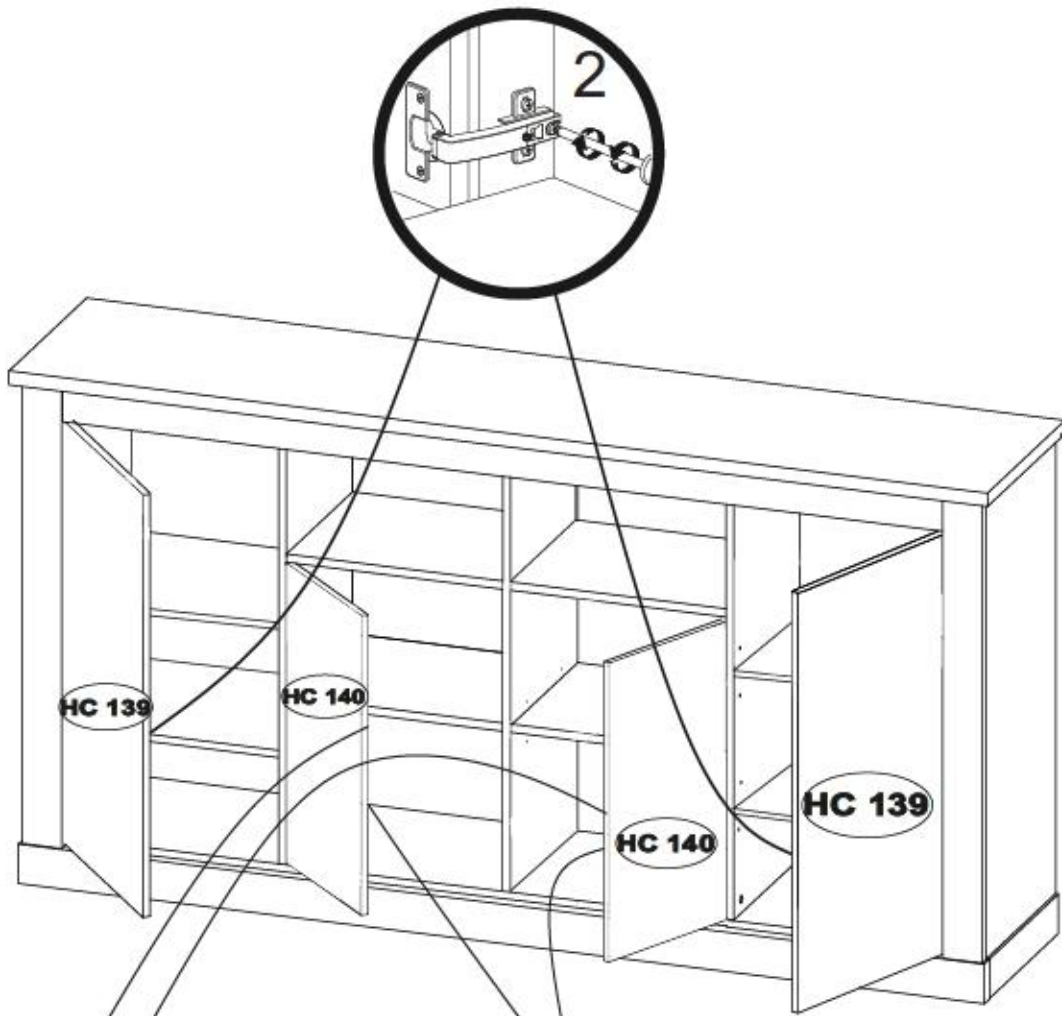

HCZ2 + HCD14

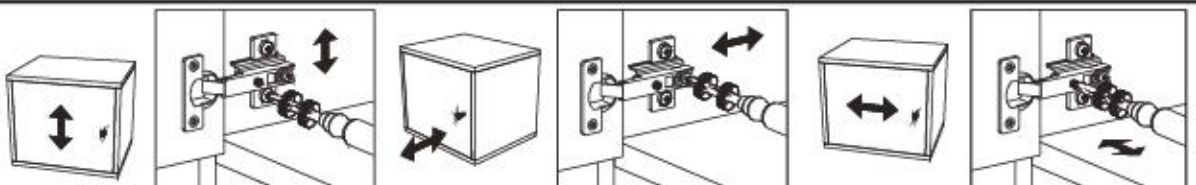

HCZ4 + HCD14

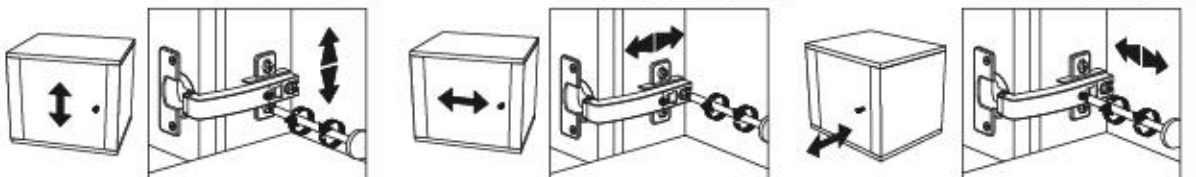

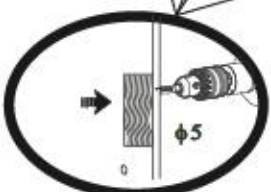
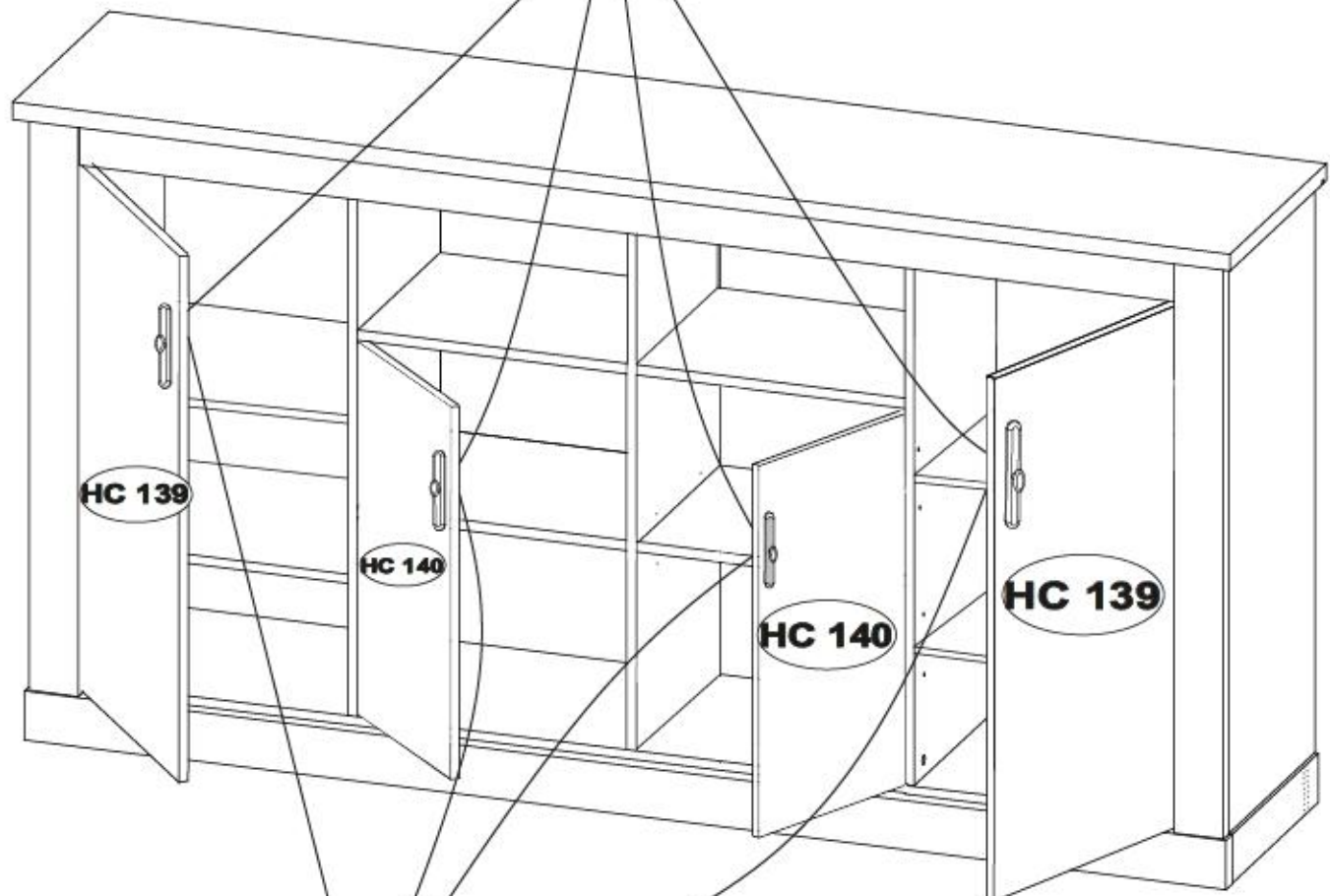
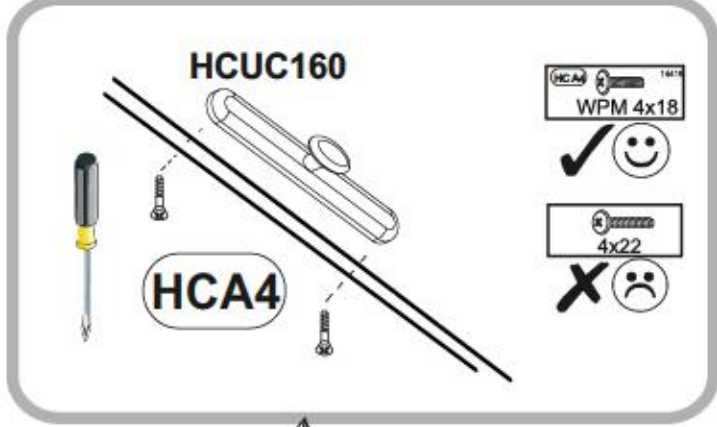
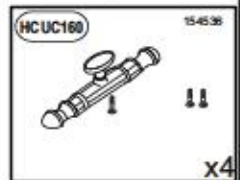
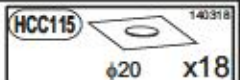



# RAVENNA 55

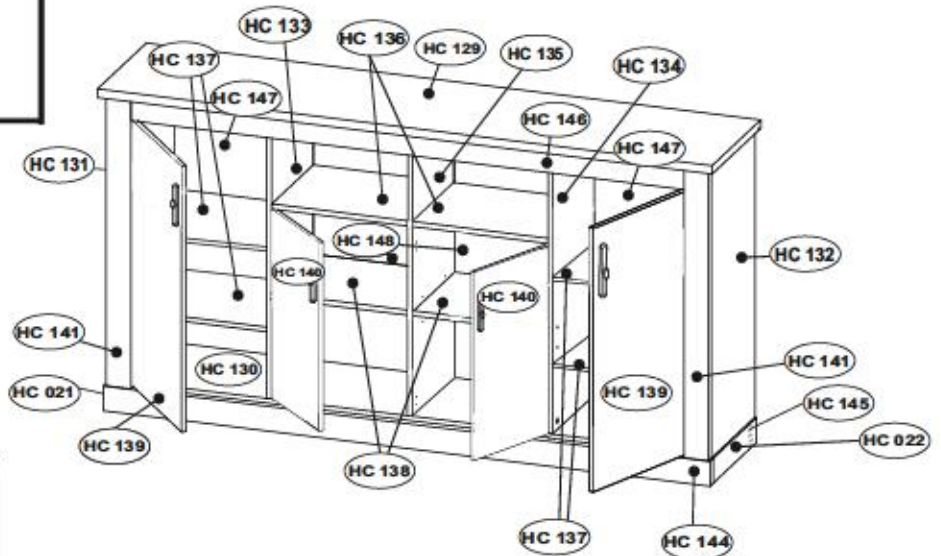

**D** Unser Dienstverbot für Beschädigung  
Sollte Ihnen ein Beschädigt werden, können Sie diese Servicekarte direkt an die untenstehende Adresse senden. Wir können allerdings nur Beschädigungen auf diesem Wege verschicken. Sollten Sie eine andere Dienstleistung an Ihrem Möbelstück haben, so wenden sie sich bitte direkt an Ihre Möbelhaus.

**GB** Our direct order service for fitting  
If a fitting part is missing, you can e-mail this service card directly to the address below. However, we can only send fitting parts in this way. If you have any other cause for complaint concerning your item of furniture, please contact your furniture store directly.

**CZ** Náš přímý službu pro kování  
Chybí-li vám nějaký díl z kování, můžete tuto servisní kartu odešlat e-mailem přímo na níže uvedenou adresu. Touto cestou však můžeme poslat jen díly kování. Pokud byste měli nějaký jiný problém, obraťte se přímo na svého prodejce nábytku.

**F** Bien sûr, il n'est pas possible de vous adresser directement la présente carte service (l'adresse e-mail indiquée ci-dessous). Cependant, ceci nous permet uniquement d'envoyer des pièces détachées. Pour tout autre type de réclamation concernant votre meuble, veuillez contacter directement votre magasin d'ameublement.

**I** Il nostro servizio diretto per il ordine delle forniture  
Qualora Vi dovesse mancare un pezzo di fissaggio, allora Vi preghiamo di inviare questa carta di servizio immediatamente all'indirizzo sottoelencato. Possiamo inviare i pezzi di fissaggio solamente per mezzo di questo procedimento. Qualora dovesse avere qualche altra reclamo in merito al mobile, allora Vi preghiamo di rivolgerVi direttamente al Vostro Negozio di mobili.

**BG** Нашата директна услуга за обвиване  
Ако липоват част от коването, потърсете нашата директна услуга за пряк и няма изпращане на място за адрес, посочен по-долу. По този начин можем да доставим само детайлни компоненти от обвиване. Ако установите други дефекти по мебелите, ще съветваме да се обърнете към вашия магазин за мебелиране, от който сте закупили стаята.

**NL** Onze directservice voor (omzet)onderdelen  
Wanneer er een onderdeel ontbreekt, kunt u deze servicekaart direct aan ons toesturen en e-mailadres sturen. Wij kunnen lange deze weg echter alleen beschadigingen versenden. Mocht u een ander probleem met uw meubel hebben, verzocht wij u contact op te nemen met uw meubelwink.

**PL** Nasa bezpośredni serwis części montażowych  
Jeżeli brakuje części koniecznych do montażu, prosimy o przelanie nam niniejszej karty serwisowej na niżej podany adres e-mailowy. W ten sposób możemy przesyłać Państwu tylko brakujące części. W przypadku innych reklamacji dotyczących mebla, prosimy zgłosić się do salonu meblowego, w którym został dokonany zakup.

**HR** Servis za okove  
U slučaju da nedostaje neki od dijelova molimo vas da ne šalje našemu mail adresu poštom već direktno na našu adresu. Na ovaj način mogu se dostaviti samo okovi. U slučaju da imate i druge prigovore vezane uz komad namještaja molimo vas da se obratite (aravno trgovini namještaja gdje je isti kupljen).

**HU** Közvetlen szolgáltatásunk részletei  
Ha hiányzik egy csavar, szelvény vagy kovácsolt alkatrész az alább felsorolt címre. Azonban csak a vasalható kiegészítőket küldhetünk. Amennyiben másfajta reklamációt állít fel, kérésüket meg kell értenünk, forduljon közvetlenül a boltvezetőhöz.

**SK** Náš priamy servis pre časti kování  
Ak by Vám chýbala nejaká časť kování, môžete poslať túto servisnú kartu priamo e-mailom na nižšie uvedenú adresu. Čiasto kování vieme poslať iba týmto spôsobom. Ak by ste mali iné reklamácie ohľadom Vašho nábytku, obráťte sa prosím na Vašu predajňu nábytku.

**SLO** Njše direktna služba storitve za okove  
Če vam manjka kakšno okovje, lahko to servišno kartico pošljete po e-pošti direktno na spodnji naslov. Po tej poti vam lahko pošljemo samo okovje. Če želite reklamirati kakšen drug del pohištva, se obrnite neposredno na vašo trgovino pohištva.

**RO** Serviciul nostru direct pentru fierzătorie  
În cazul în care vă lipsește o piesă de fierzătorie puteți să trimiteți direct această card de service prin e-mail la adresa de mai jos. Nu putem trimite prin poșta decât piese de fierzătorie care se pot fierza. Dacă aveți o altă reclamație referitoare la piesa de mobilier, atunci vă rugăm să vă adresați direct furnizorului dvs. de mobilier.

**RUS** Наш прямой сервис для поставки фурнитуры  
Если окажется, что Вам не хватает того или иного элемента на фуре, шуруп, Вы можете отправить сервисную карту по адресу, не опускаясь ни на неопределенный адрес, а отправив по почте. Однако, только в таком случае мы сможем отправить детали фурнитуры. Если же у Вас возникнут иные претензии относительно приобретения мебели, пожалуйста, обратитесь непосредственно к организаторам, а также связаться продавцу.

**S** Vše direktno se for besškodje  
Om du saknar en beskadigad del du skicka detta servicenkort direkt till e-postadressen som anges nedan. Tank på att detta är den enda möjligheten att skicka beskadigade delar. Om du vill reklamera din möbel annan orsak än beskadigade delar ska du kontakta ditt möbelhus direkt.

**ES** Nuestro servicio directo para reparaciones  
Si le falta algún accesorio, puede enviar esta tarjeta de servicio directamente a la siguiente dirección. No obstante, por este método solo podemos enviar accesorios. Si tiene alguna otra objeción sobre su mueble, consulte directamente con su vendedor.

**TR** Doğrudan hizmet için servis kartı  
Bir dan alınız aksesuar bu servis kartını doğrudan aşağıdaki bulunan adrese doğrudan mail yoluyla gönderin. Sadece bu yolla doğrudan aksesuarları gönderebilirsiniz. Mobilyanızda başka bir şekilde oluşan veya malzeme defektleri doğrudan satışçıyla iletişime geçin.

AI No.	Qty	H	W	D	PKG
HC 021	x1	386	80	28	1/2
HC 022	x1	386	80	28	1/2
HC 129	x1	2003	431	28	2/2
HC 130	x1	1931	369	15	2/2
HC 131	x1	894	389	15	1/2
HC 132	x1	894	389	15	1/2
HC 133	x1	879	368	15	2/2
HC 134	x1	879	368	15	2/2
HC 135	x1	879	368	15	2/2
HC 136	x2	435	367	15	2/2
HC 137	x4	507	360	15	1/2
HC 138	x2	434	360	15	1/2
HC 139	x2	814	447	15	1/2
HC 140	x2	644	447	15	1/2
HC 141	x2	894	80	22	1/2
HC 144	x2	1976	80	28	2/2
HC 145	x1	1918	80	28	2/2
HC 146	x1	1803	74	18	2/2
HC 147	x2	899	521	2,5	1/2
HC 148	x2	899	449	2,5	1/2



# RAVENNA 55

**HCB1**  1018  
8x28 X...

**HCM1**  123894  
X...

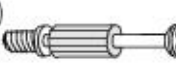
**HCT1**  11809  
X...

**HCJ23**  1302  
X...

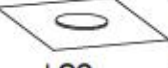
**HCC115**  140318  
φ20 X...

**HCW1**  1289  
X...

**HCF1**  1415  
X...

**HCK15**  81556  
X...

**HCF44**  116795  
X...

**HCT3**  15824  
L-64 X...

**HCH2**  22311  
φ35 Kr8 X...

**HCUC160**  154536  
X...

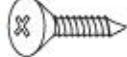
**HCS3**  1011  
3,5x13 X...

**HCJ11**  1267  
X...

**HCF36**  1305  
X...

**HCF14**  1021  
X...

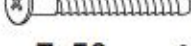
**HCK1**  1354  
7x50 X...

**HCA4**  14419  
WPM 4x18 X...

**HCK13**  49716  
X...

**HCP6**  1056  
3x20 X...

**HCD14**  23515  
H4 X...

**HCZ4**  49365  
φ35 90° X...

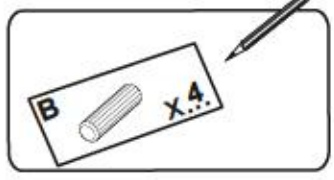

**D** Unser Direktservice für Beschädigte  
Sollte Ihnen ein Beschädigtes fehlen, können Sie diese Servicekarte direkt an die untenstehende Adresse mailen. Wir können allerdings nur Beschädigte auf diese Weise verschicken. Sollten Sie eine andere Beschwerdeung an Ihrem Möbelstück haben, so wenden sie sich bitte direkt an Ihr Möbelhaus.

**GB** Our direct order service for fitting  
If a fitting part is missing, you can e-mail this service card directly to the address below. However, we can only send fitting parts in this way. If you have any other cause for complaint concerning your item of furniture, please contact your furniture store directly.

**CZ** Naše přímé služby pro kování  
Chybí-li vám nějaký díl z kování, můžete toto servisní kartičku odeslat e-mailem přímo na níže uvedenou adresu. Touto cestou však můžeme zasílat jen díly kování. Pokud byste měli nějaký jiný díl nábytku, obraťte se přímo na svého prodejce nábytku.

**F** Siens service à la notice de montage  
Si vous manquez une pièce, veuillez envoyer directement la présente carte service à l'adresse e-mail indiquée ci-dessous. Cependant, nous ne pouvons que vous renvoyer des pièces de rechange de cette manière. Pour tout autre type de réclamation ou concernant votre meuble, veuillez contacter directement votre magasin d'ameublement.

**I** Il nostro servizio diretto per l'ordine della ferramenta  
Qualora Vi dovesse mancare un pezzo di fissaggio, allora Vi preghiamo di inviare questa carta di servizio immediatamente all'indirizzo sottostante. Possiamo inviare i pezzi di fissaggio solamente per mezzo di questo procedimento. Qualora dovesse avere qualche altra reclamazione in merito al mobile, allora Vi preghiamo di rivolgerVi direttamente al Vostro negozio di mobili.

**BG** Непосредствено обслужаване на обзавеждане  
Ако липсва част от мебелите, можете да поискате необходимите части на е-поща на адреса по-долу. Можем да ви доставим само частите за мебели, а не и други части на мебелите. Ако имате друга причина за жалба, моля да се свържете директно с магазините за мебели.

**NL** Onze directservice voor losse onderdelen  
Wanneer er een onderdeel ontbreekt, kunt u deze servicekaart direct aan ons toesturen e-mailadres sturen. Wij kunnen lange deze weg echter alleen losse onderdelen verzenden. Mocht u een ander probleem aan uw meubel hebben, verzoeken wij u contact op te nemen met uw meubeldealer.

**PL** Nasz bezpośredni serwis części meblowych  
Jeżeli brakuje części koniecznych do montażu, prosimy o przesłanie nam niniejszej karty serwisowej na niżej podany adres e-mailowy. W ten sposób możemy przesłać Państwu tylko brakujące części. W przypadku innych reklamacji dotyczących mebli, prosimy zgłosić się do salonu meblowego, w którym został dokonany zakup.

**HR** Servis za otklon  
U slučaju nedostajke nekih od dijelova meblima vas da na dalje nekadnu mail adresu pošaljete ovoj servisnoj kartici. Na ovaj način mogu se dostaviti samo dijelovi. U slučaju da imate dodatne prigovore vezane uz komad namještaja molimo vas da se obratite izravno trgovini namještaja gdje je isti kupljen.

**HU** Közvetlen szolgáltatás a hiányzó részekre  
Ha hiányzik egy részlet, azt a kártyát kitöltve e-mail címetre küldheti a hiányzó részeket. Azonban csak a hiányzó részeket tudjuk így küldeni. Amennyiben másféle reklamációt kíván bejelenteni, kérjük, forduljon közvetlenül a boltihoz.

**SK** Naše priame služby pre chýbiace komponenty  
Ak by Vám chýbala niektorá časť kování, môžete poslať túto servisnú kartičku priamo e-mailom na nižšie uvedenú adresu. Čaký kování a výmena sú však týmto spôsobom možná. Ak by ste mali inú reklamáciu o ohľadom nábytku, obráťte sa priamo na Vašu predajňu nábytku.

**SLO** Naše direktno pošiljano službo za otklon  
Če vam manjka kakikoli delov, lahko to servisu kartico pošljete po e-pošti direktno na spodnji naslov. Po tej poti vam lahko pošljemo samo delove. Če želite reklamirati kakšen drug del pohištva, se obrnite neposredno na vašo trgovino pohištva.

**RO** Serviciu-ul nostru direct pentru reparatii  
In cazul in care va lipseste o piesa de mobilier puteti sa trimiti direct acest card de service prin e-mail la adresa de mai jos. Noi nu putem expedia piese de mobilier direct pe aceasta cale. Dacă a vătră altă reclamație referitoare la piesa de mobilier, atunci vă rugăm să vă adresați direct la magazinul dvs. de mobilă.

**RUS** Наш прямой сервис для поставки недостающих деталей  
Если отсутствует, что Вам не хватает того или иного элемента фурнитуры, Вы можете отправить сервисную карту по факсу или посредством не электронной почты. Однако, только образом мы можем предоставить только недостающие детали. Если же у Вас имеются другие претензии относительно приобретенной мебели, пожалуйста, обращайтесь непосредственно в магазин, осуществляющий продажу.

**S** Unser Direktservice für beschädigte  
Um du einen fehlenden Teil zu bekommen, kannst du diese Karte direkt an die untenstehende Adresse mailen. Wir können allerdings nur beschädigte Teile auf diese Weise verschicken. Sollten Sie eine andere Beschwerdeung an Ihrem Möbelstück haben, so wenden sie sich bitte direkt an Ihr Möbelhaus.

**ES** Nuestro servicio directo para accesorios  
Si le falta algún accesorio, puede enviar esta tarjeta de servicio directamente a la siguiente dirección. No obstante, por esta vía solo podemos enviar accesorios. Si tiene alguna otra objeción sobre su mueble, consulte directamente con su mueblista.

**TR** Doğrudan hizmet için doğrudan servis kartı  
Bir donanım eksikliği bu servis kartini doğrudan aşağıdaki bulan adrese doğrudan mail yoluyla gönderebilirsiniz. Sadece bu yolla donanım parçalarını gönderebiliriz. Mübelleğinizin başka bir parçasıyla ilgili varsa diğer doğrudan mobilya satıcınıza danışın.