

6623325

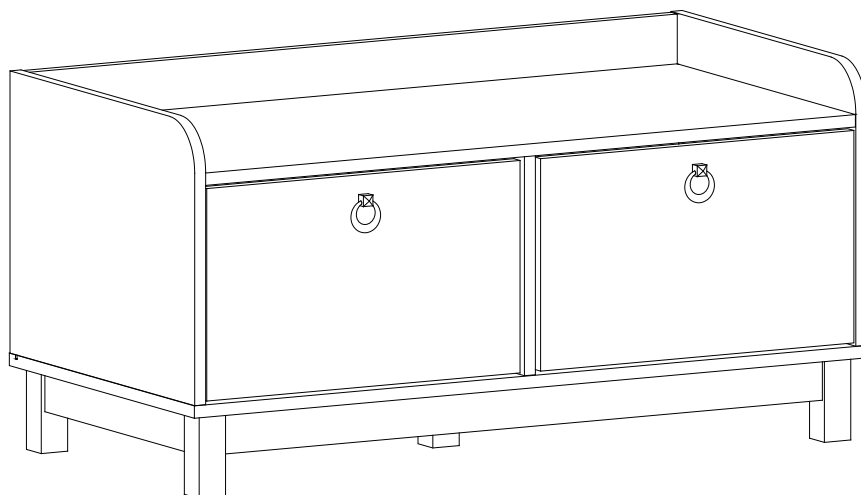

- | | | | |
|-----------|-----------------------------|-----------|-------------------------|
| D | Montageanleitung | GB | Assembly instructions |
| FR | Notice de montage | IT | Istruzioni di montaggio |
| NL | Handleiding voor de montage | PL | Instrukcja montażu |
| CZ | Montážní návod | SK | Návod na montáž |
| HU | Szerelési útmutató | RO | Instructiuni de montaj |
| TR | Montaj talimatı | RU | инструкция по монтажу |

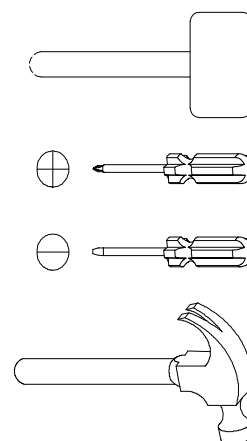

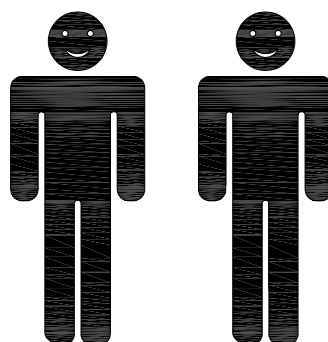







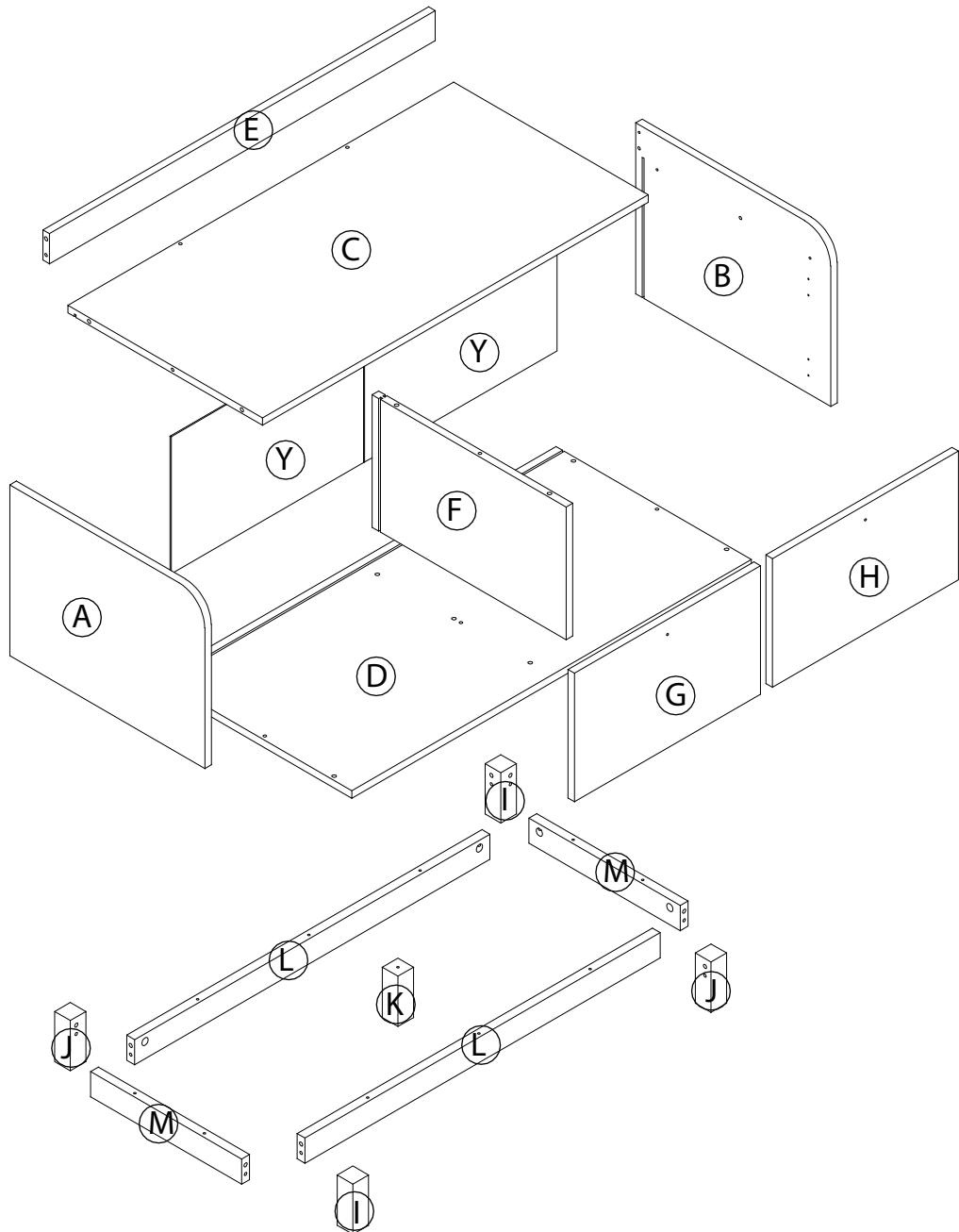
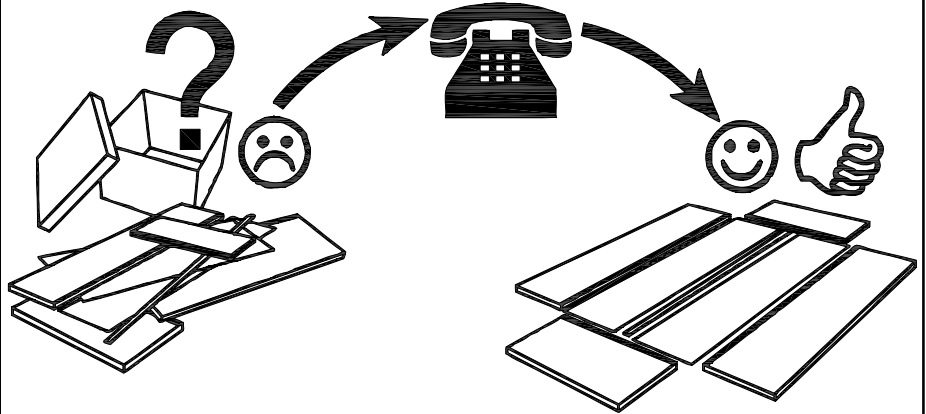
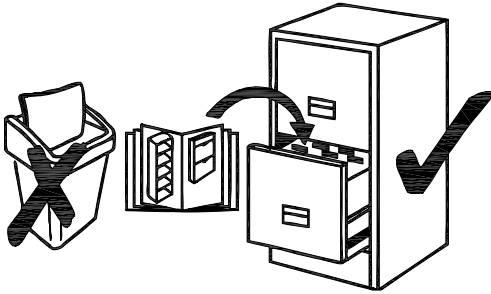

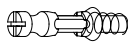
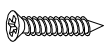

Service • Assistenza • Dienstverlening • Serwis Servis • Szerviz • Сервисная служба

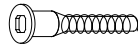
Name • Nom • Nome • Naam •
Nazwa • Jméno • Názov • Név •
Denimire • Isim • Название

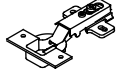
Nr. • No. • N° • Номер • Č • Sz

Typ • Type • Tip • Típus • Tipo •
Тип



1		MINIFIX M5 X 29MM	16	8		CSK SCREW M4.7 X 38MM	10
2		CAM 15/12	16	9		HANDLE SCREW M4 X 23MM	2
3		PLASTIC DOWEL Ø8 X 30MM	18	10		HANDLE	2
4		UNITAR SCREW 6.3 x 40MM	7	11		DOOR STOPPER	2
5		HINGES 7/8	4	12		BACKPLY STOPPER	8
6		CSK SCREW M3.5 X 15MM	16	13		CUSHION PAD	5
7		CSK SCREW M3.1 X 20MM	8	14		ALLEN KEY M4	1

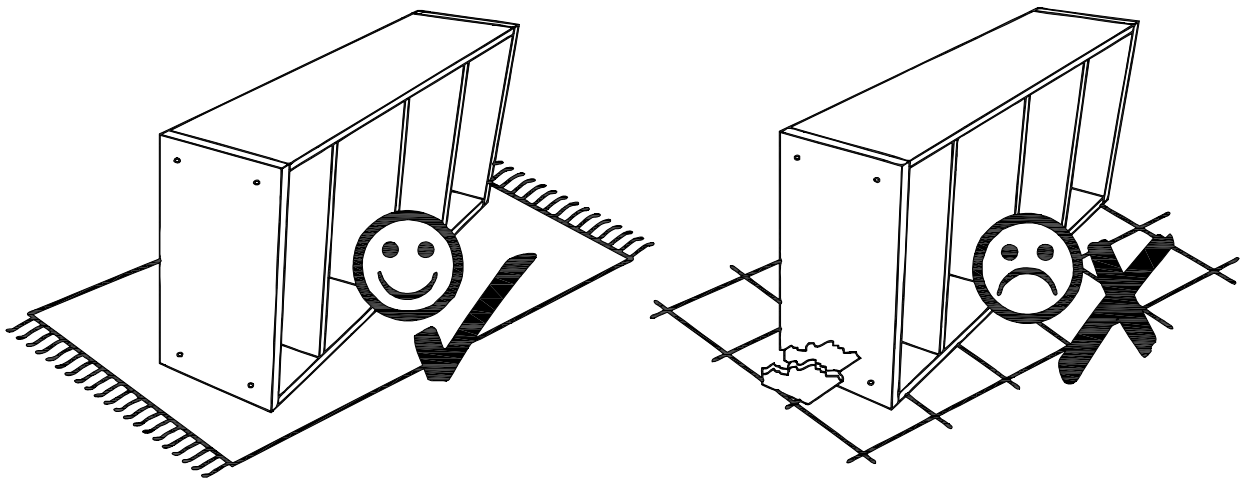

1

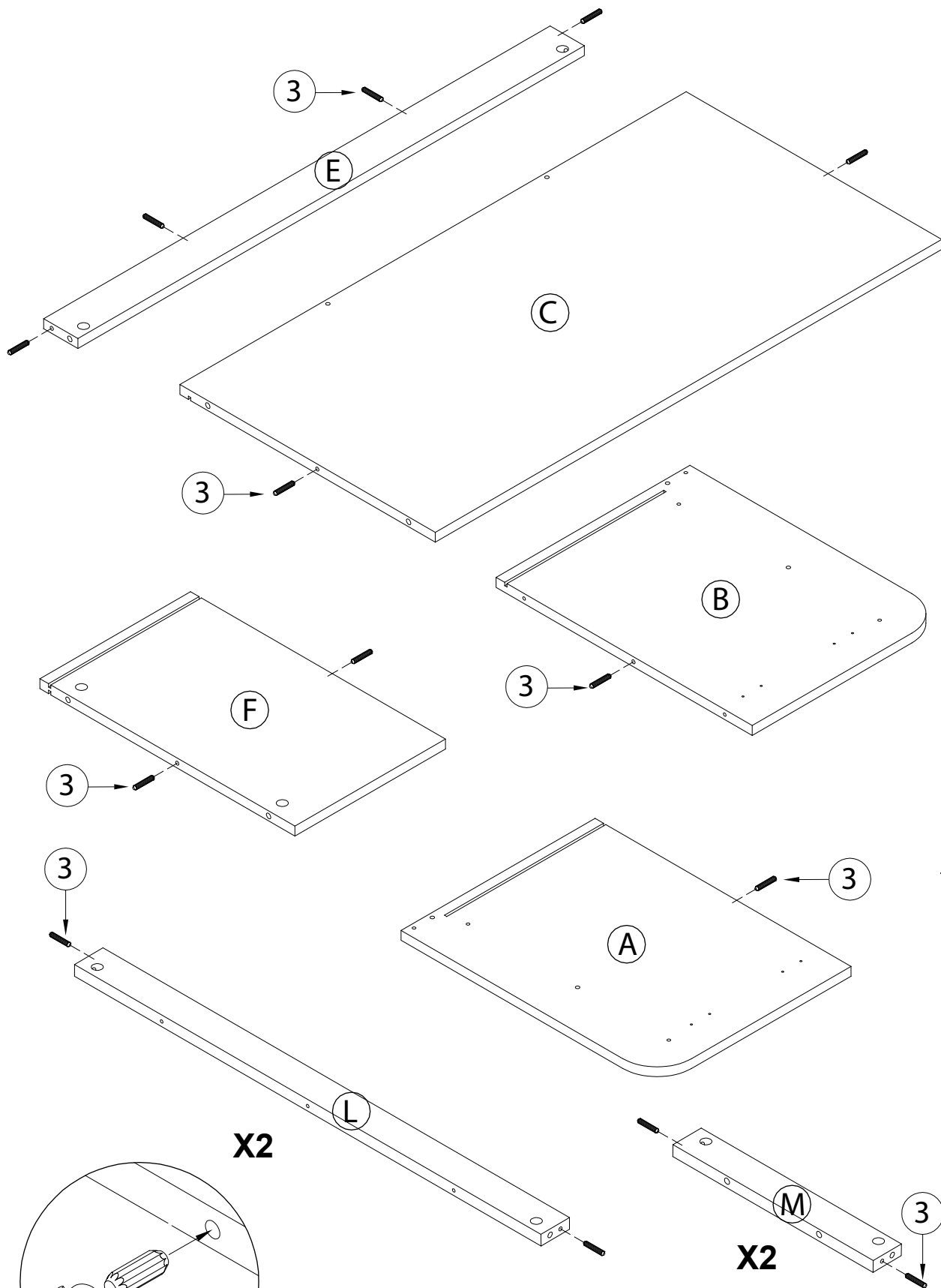

3 X18



2

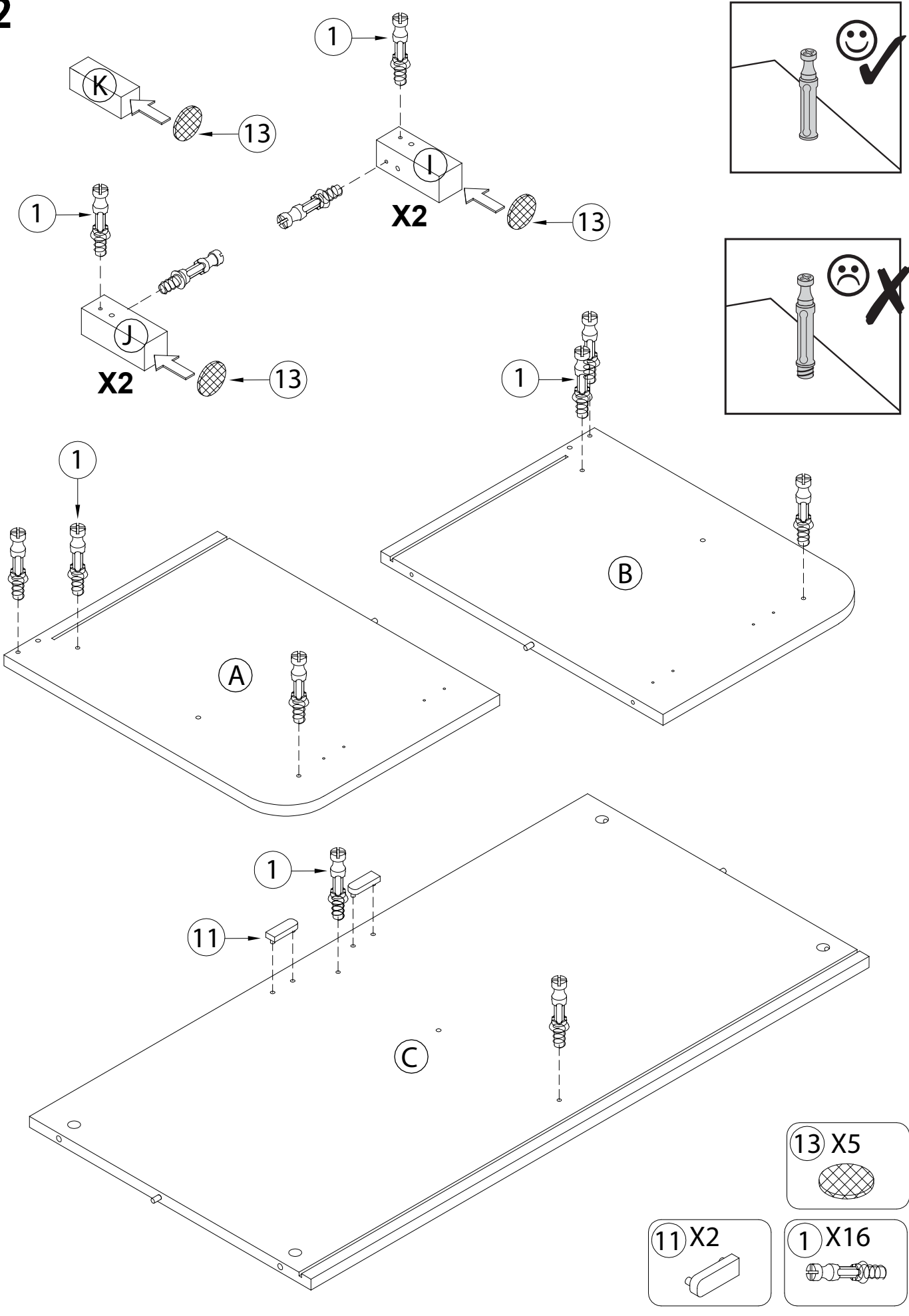

3

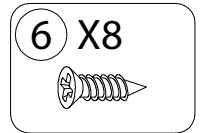
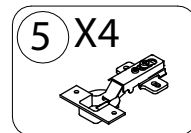
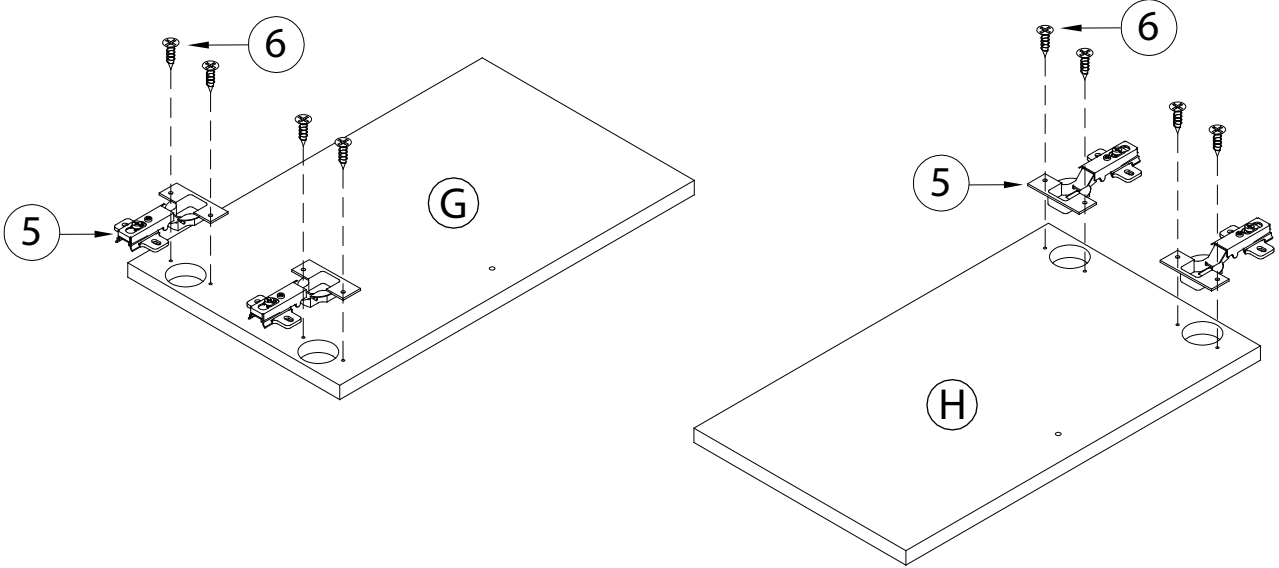

4

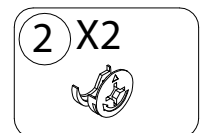
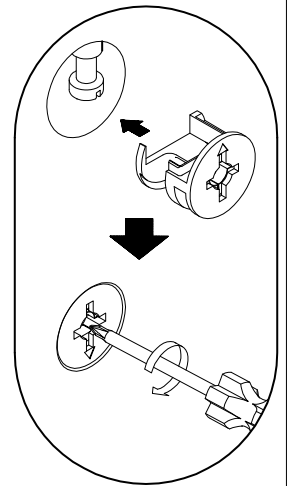
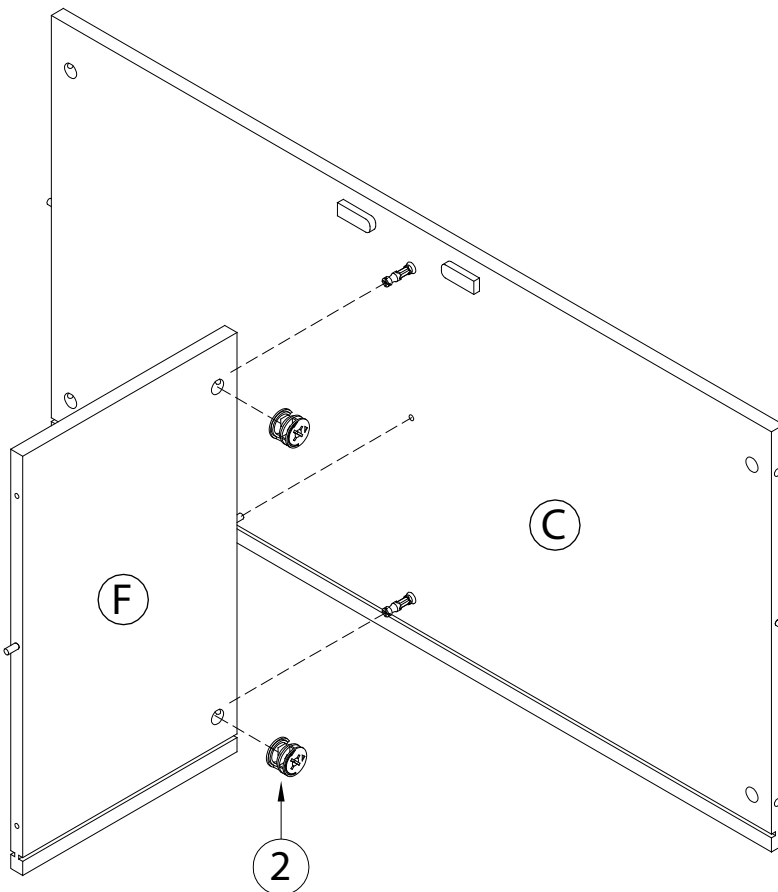

5

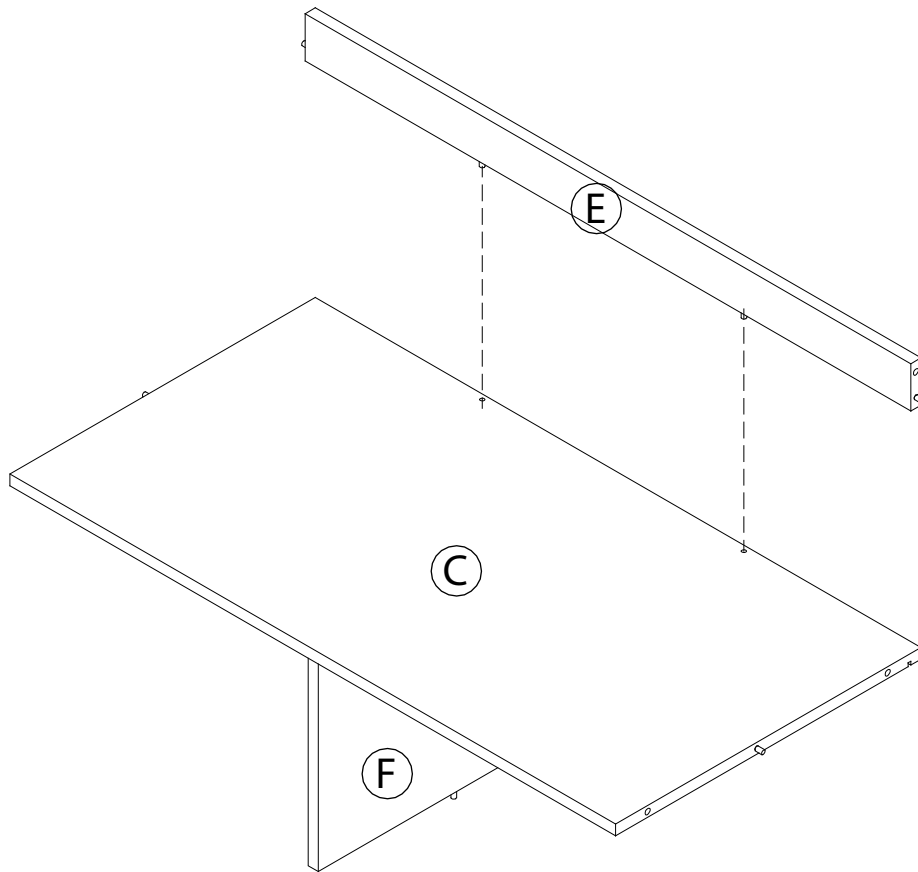

6

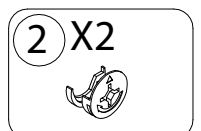
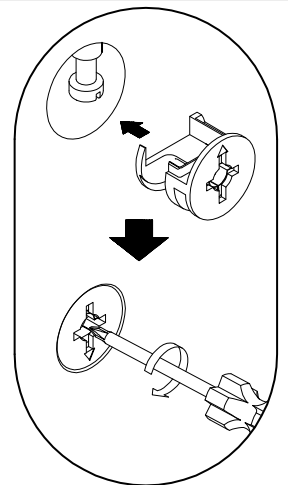
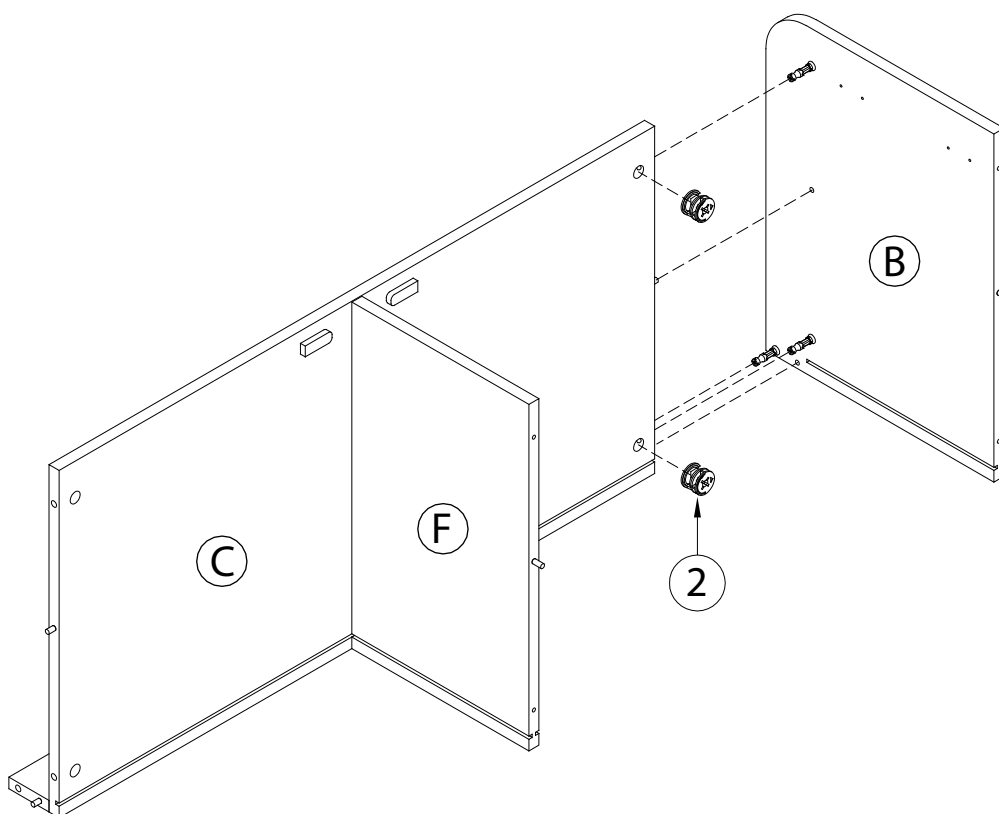

7

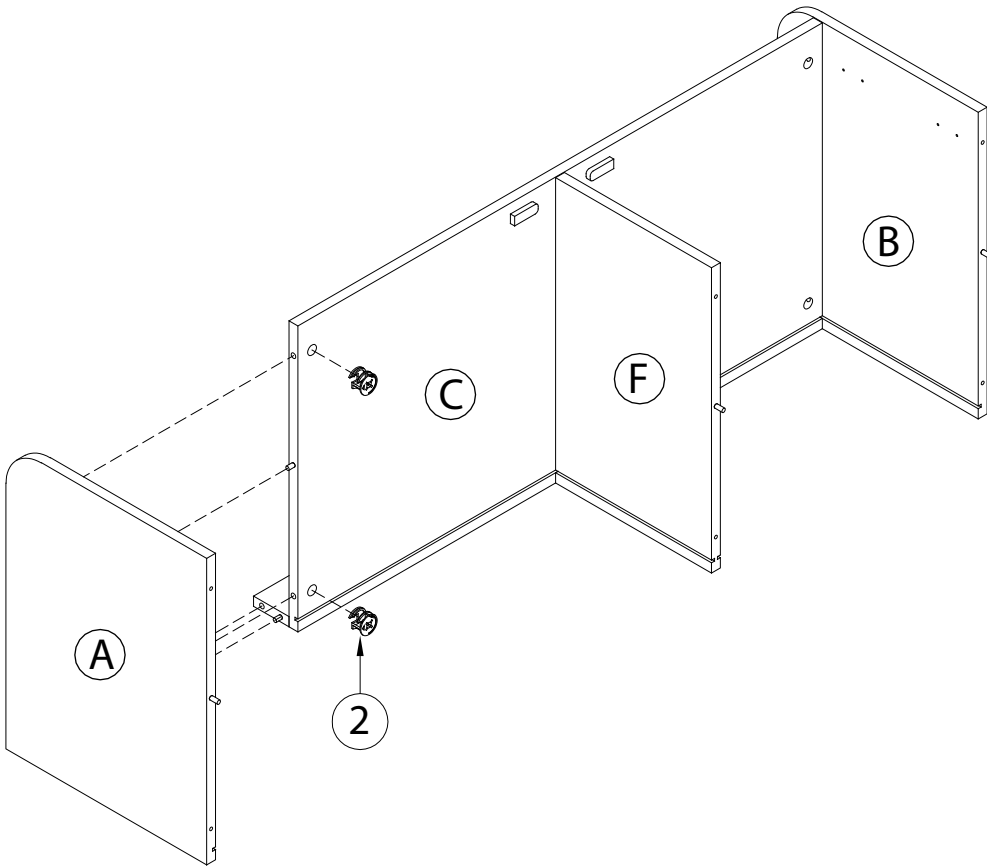

8

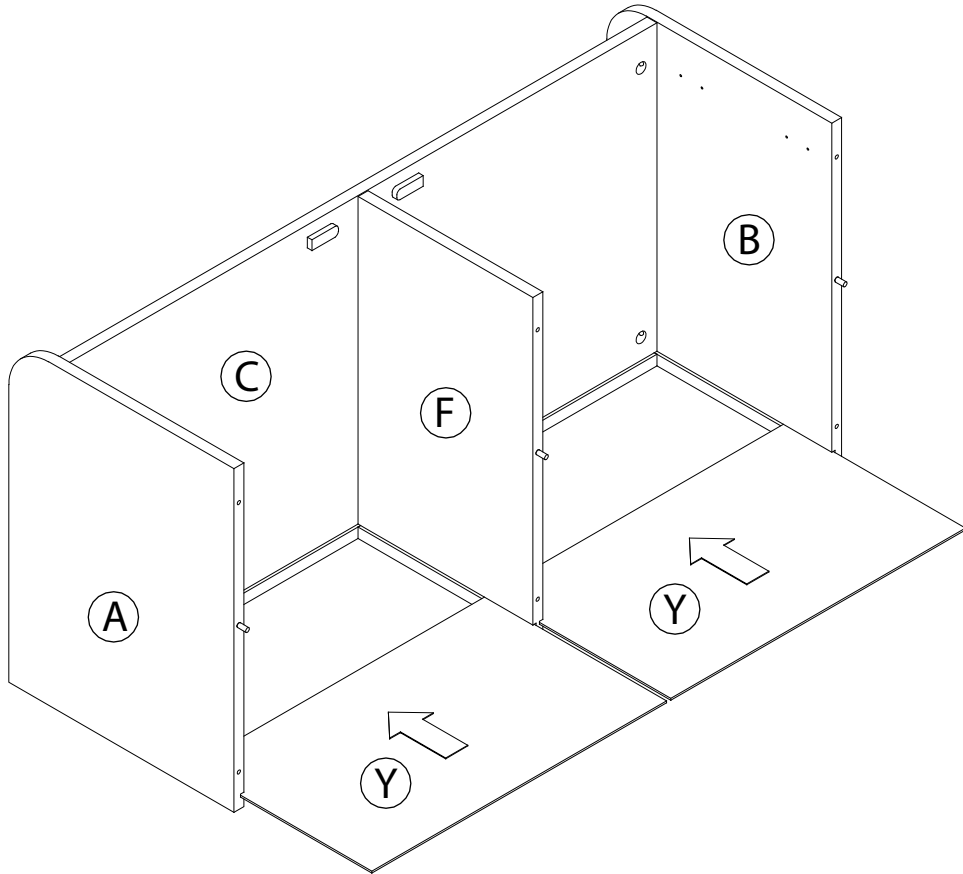

9

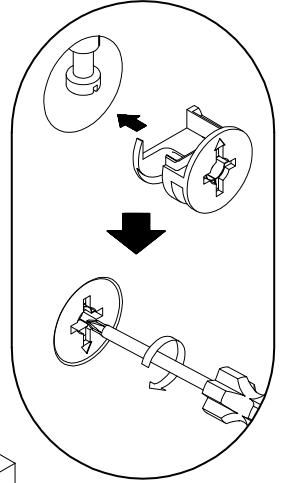
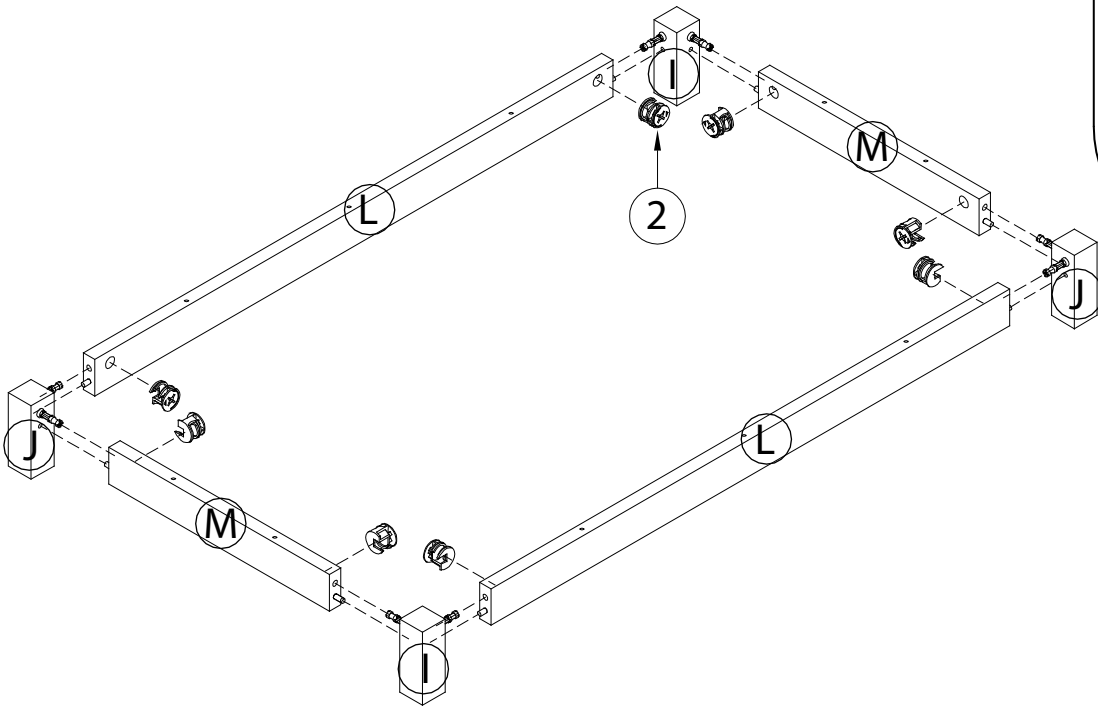

2 X8

10

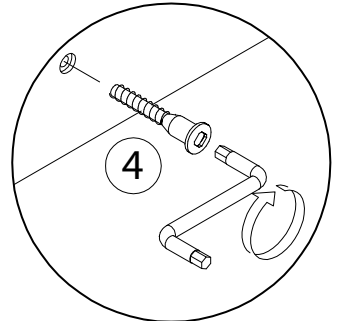
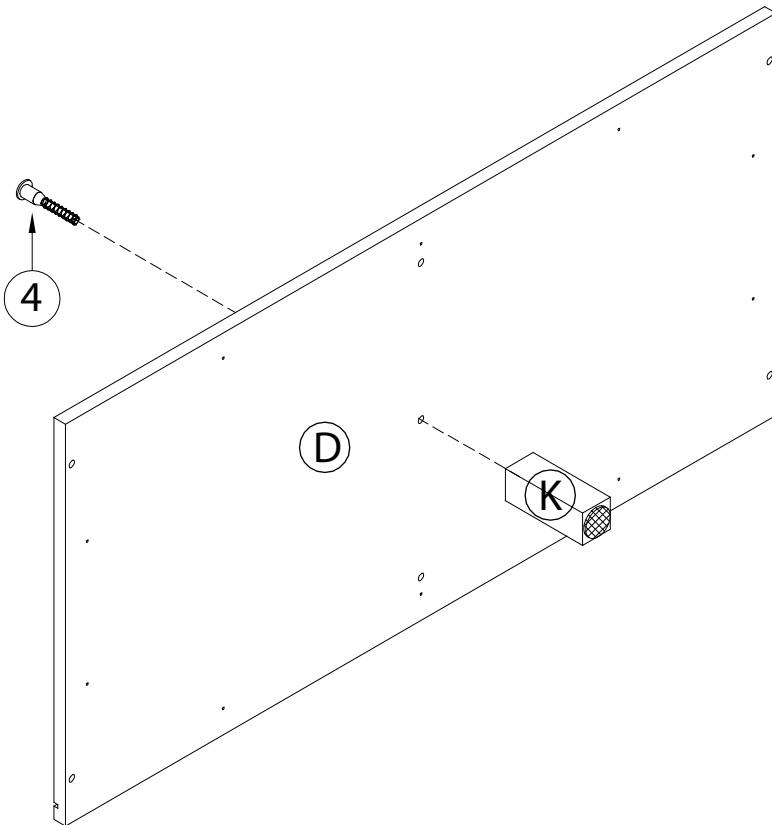

4 X1

14

11

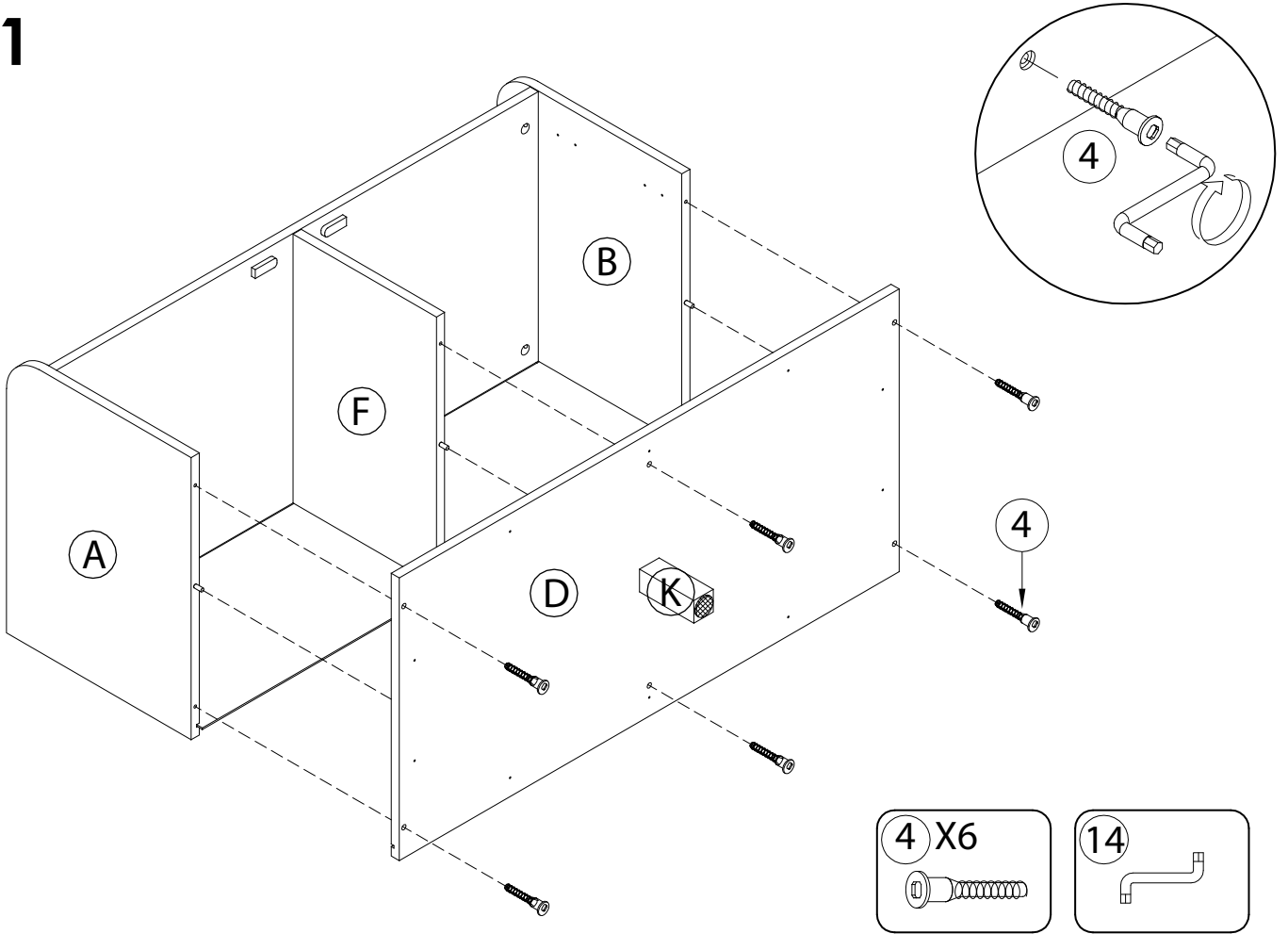

12

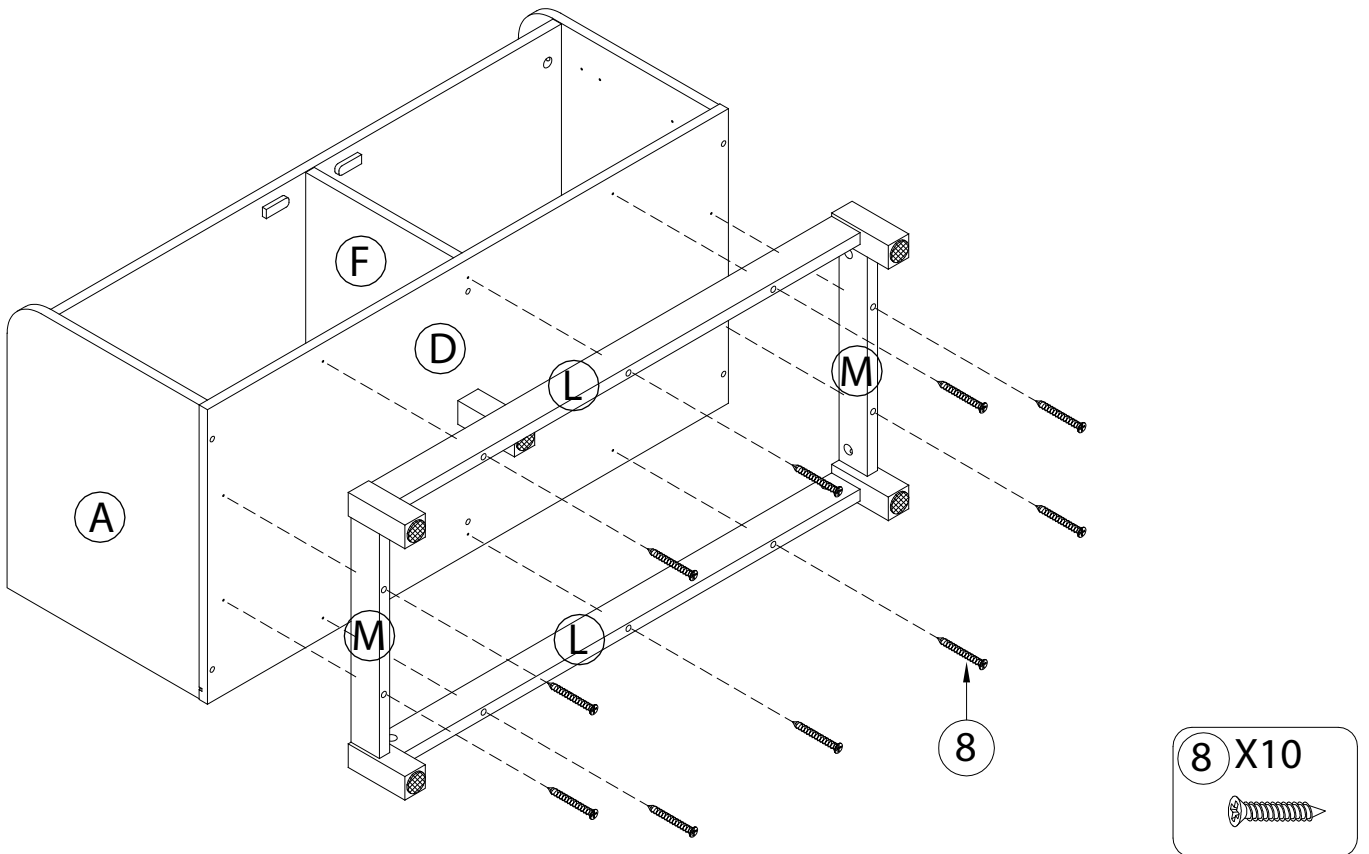

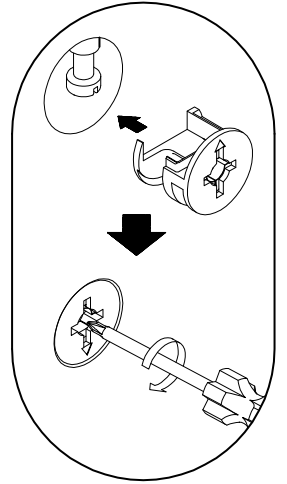
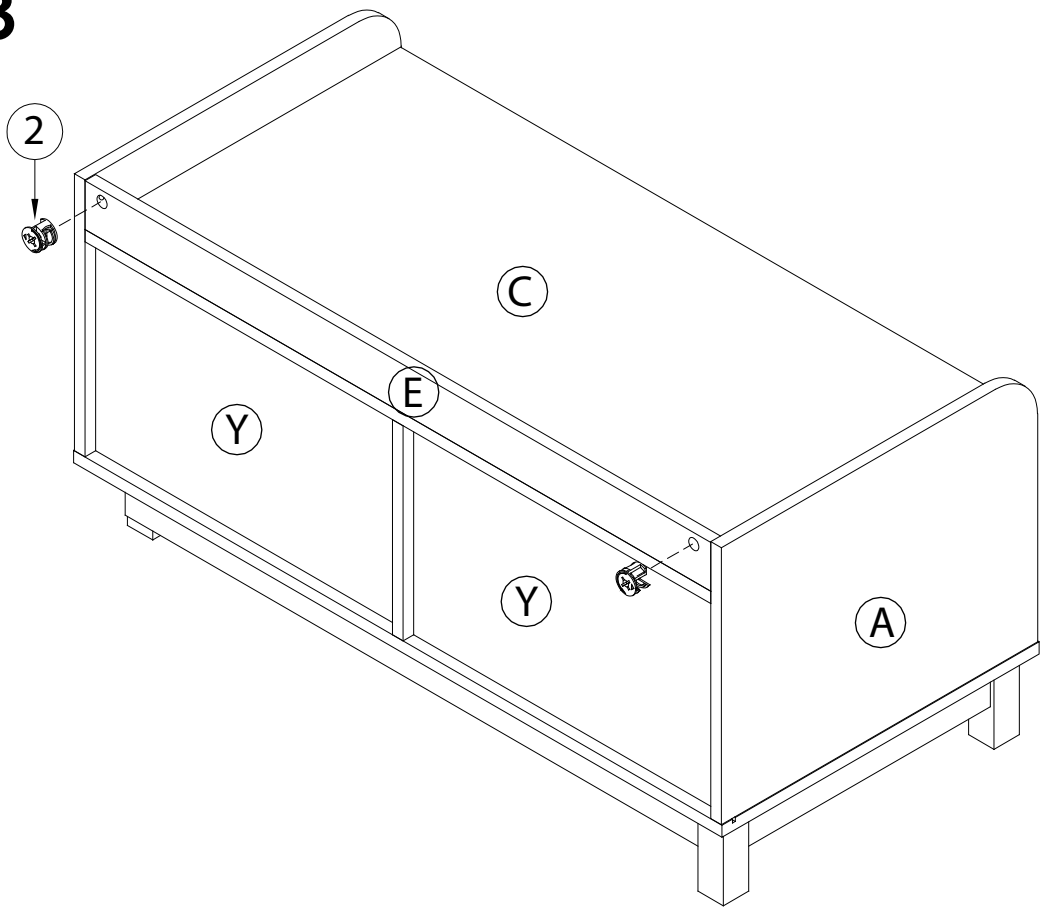

13

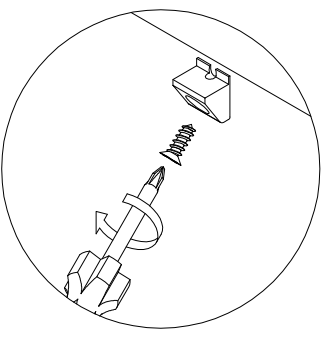
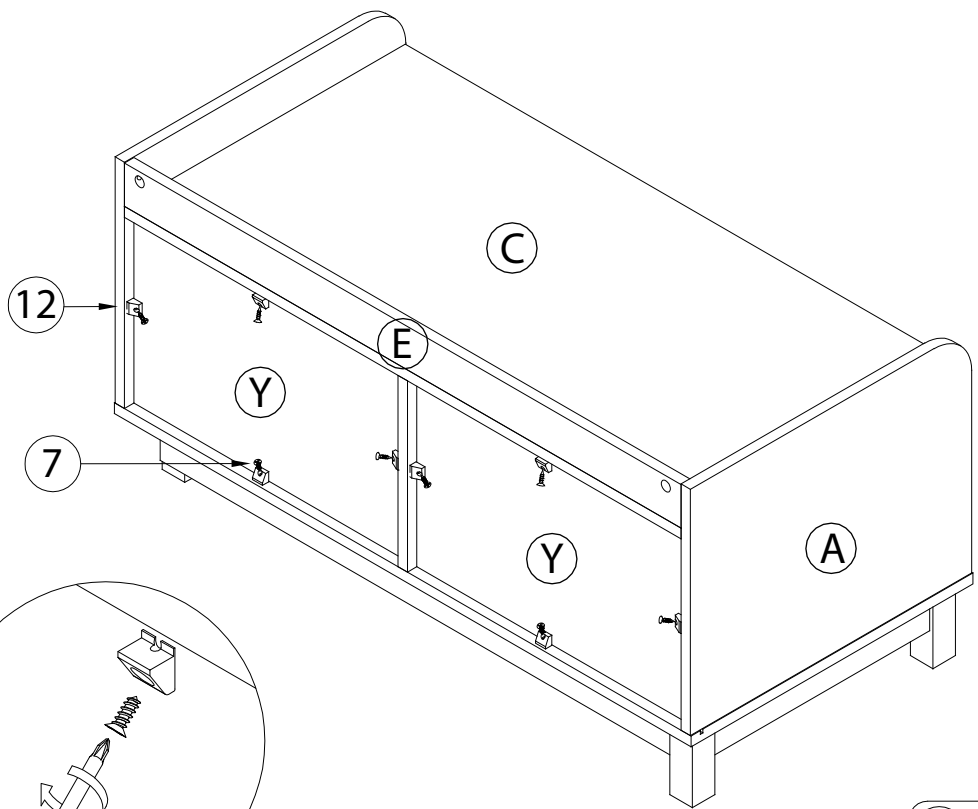

2 X2

14



12 X8

7 X8



**Achtung • Attention • Attenzione • Opgelet • Uwaga • Pozor • Figyelem • Atenție •
Dikkat • Вниманіе**



(D)	<i>Türen einstellen (Scharniere justieren)</i>
(GB)	<i>Adjusting the doors (adjusting the hinges)</i>
(NL)	<i>Deuren instellen (scharnieren afstellen)</i>
(PL)	<i>Nastawić drzwi (wyrównać zawiasy)</i>
(TR)	<i>Kapıların ayarlanması (menteselerin seviye ayarı)</i>
(RU)	<i>Регулировка дверей (регулировка шарнира)</i>
(FR)	<i>Régler les portes (ajuster les charnières)</i>
(IT)	<i>Sistemare la porte (regolare le cerniere)</i>
(CZ)	<i>Vyrovnejte dvířka (seřďte závěsy)</i>
(SK)	<i>Nastavenie dverí (nastavenie závesov)</i>
(HU)	<i>Állítsa be az ajtókat (állítsa be a zsanérokat)</i>
(RO)	<i>Reglare ușii (ajustare balamale)</i>

15

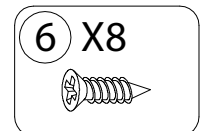
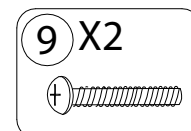
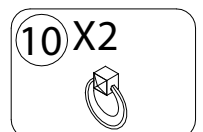
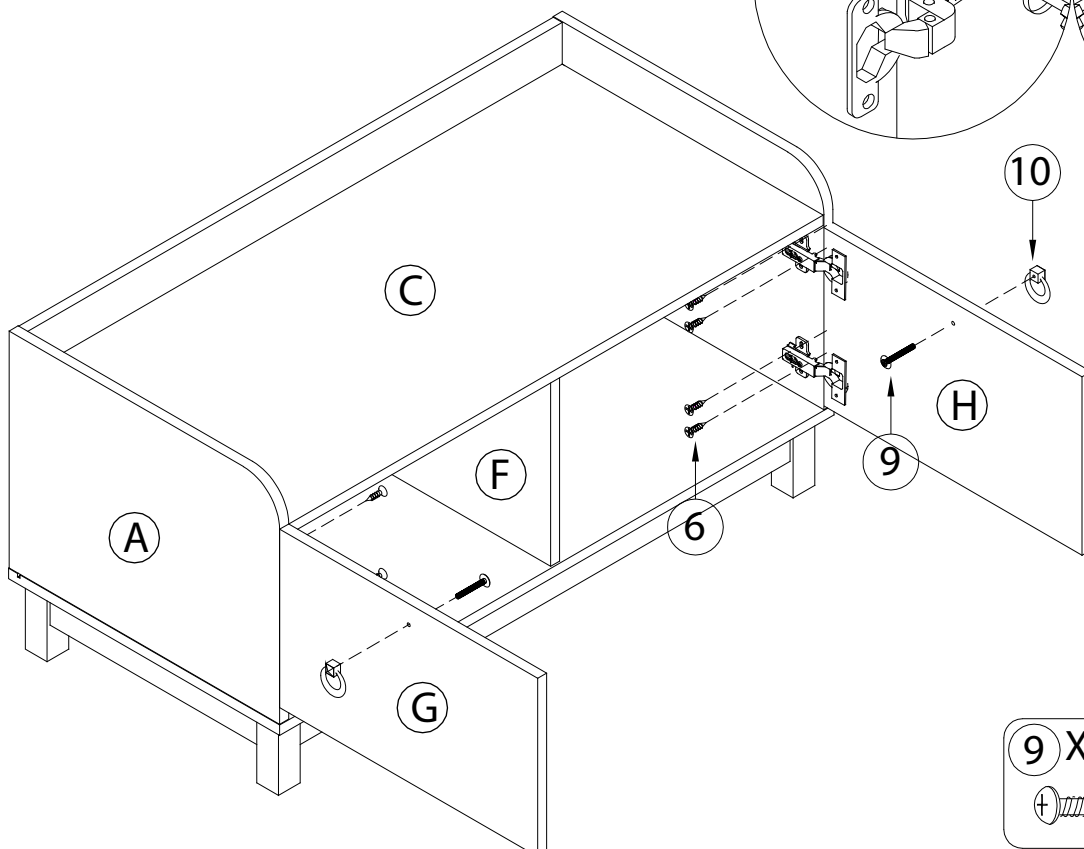
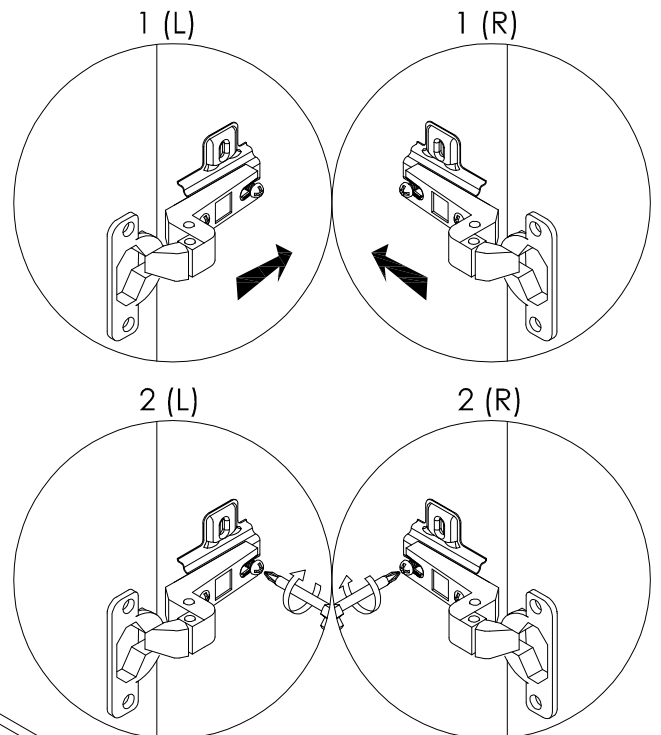
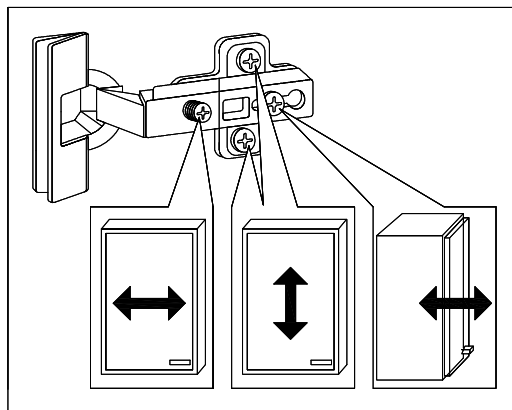

D	Bitte nur mit einem Staubtuch oder leicht feuchtem Lappen reinigen. Keine scheuernden Putzmittel verwenden.
GB	Please only clean with a duster or a damp cloth. Do not use any abrasive cleaners.
FR	Veillez nettoyer uniquement avec un chiffon à poussière ou un chiffon légèrement humide. Ne pas utiliser de détergent abrasif.
IT	Si raccomanda di pulire solo con un panno per la polvere o uno strofinaccio umido. Non utilizzare detersivi abrasivi.
NL	Reinig alleen met een stofdoek of een lichtjes vochtige doek. Gebruik geen schurende poetsmiddelen.
PL	Czyszczenie należy wykonać wyłącznie za pomocą ściereczki lub lekko nawilżonego ręcznika. Nie stosować środków czyszczących do szorowania.
CZ	Čistěte prosím jen prachovkou nebo lehce navlhčeným hadrem. Nepoužívejte drhnutí čistící prostředky.
SK	Na čistenie používajte len prachovku alebo z ľahka navlhčenú utierku. Nepoužívajte žiadne drhúce čistiace prostriedky.
HU	Kérjük, csak portörővel vagy enyhén nedves ronggyal tisztítsa. Ne használjon dörzsológépet tisztítószert.
RO	Vă rugăm să utilizați la curățare exclusiv o cârpă de șters praful sau o cârpă ușor umezită. Nu utilizați substanțe de curățat abrazive.
TR	Lütfen sadece bir toz bezile veya hafif nemli yumuşak bir bezle siliniz. A şındırıcı temizlik malzemeleri kullanmayınız.
RU	Очищайте от пыли тряпкой или слегка влажной ветошью. Не допускается применение чистящих средств, не предназначенных для ухода за мебелью.