

Montageanleitung | Instructions de montage Assembly Instructions | Instrucciones de montaje

SKU NUMBER: WF531487/WF531488
WF531489/WF531490
WF531491/WF531492

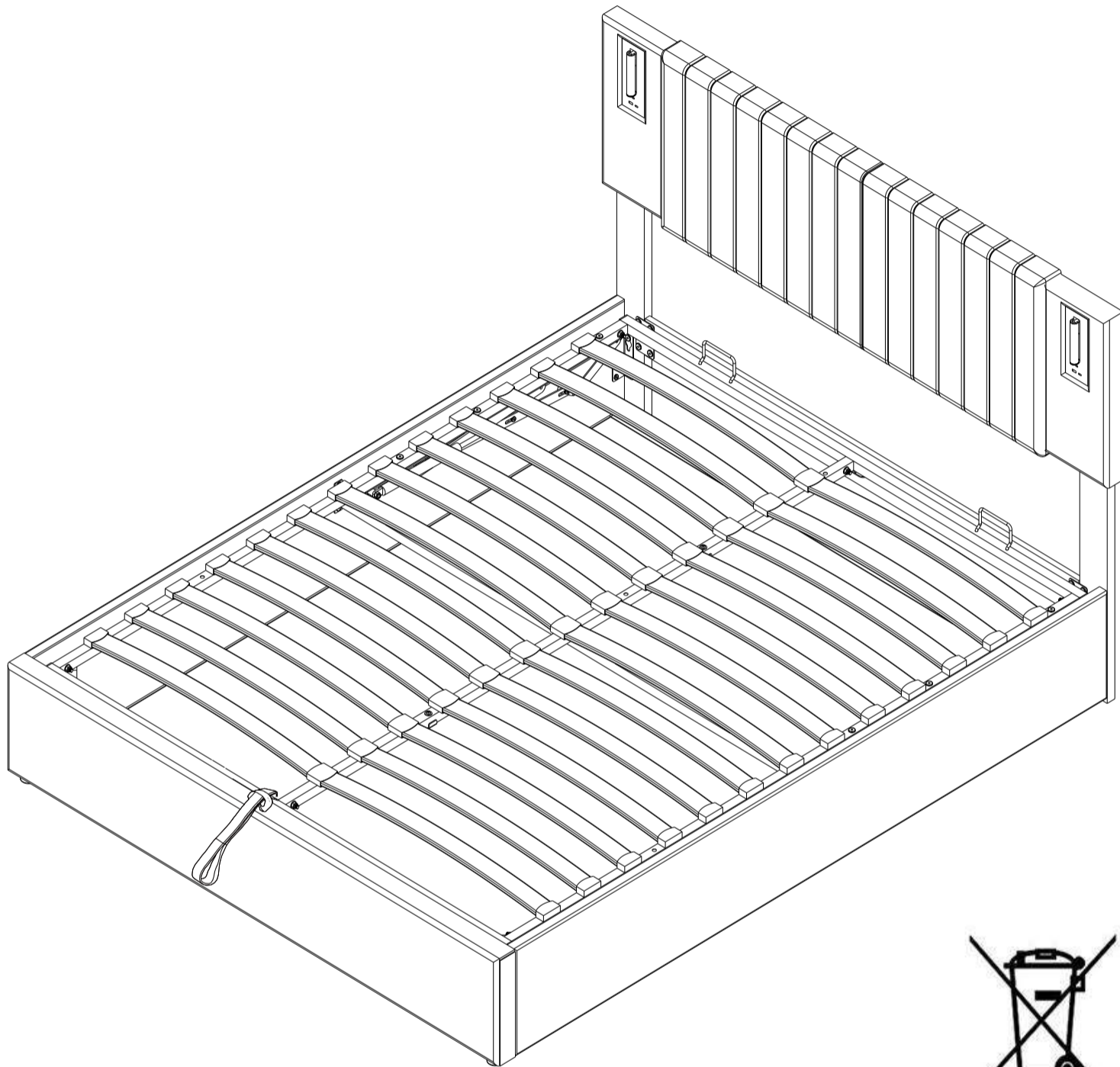

GB This set comes in 2 boxes. If you do not receive a full set of 2 boxes, please contact our customer service.

DE Dieses Set wird in 2 Schachteln geliefert. Wenn Sie nicht ein komplettes Set von 2 Boxen erhalten, kontaktieren Sie bitte unseren Kundenservice.

FR Ce set est livré en 2 boîtes. Si vous ne recevez pas un jeu complet de 2 boîtes, veuillez contacter notre service clientèle.

English

IMPORTANT ! KEEP FOR FUTURE REFERENCE : READ CAREFULLY

- To be assembled by an adult. Assembly must be checked by an adult before use
- WARNING ! Keep all screws, small parts and plastic bags out of the reach of children
- Properly identify all parts before assembling
- Never use your item if any of its parts are broken or missing
- Should any problems arise, please contact our After Sales Service
- Manufacturer's instructions shall be followed at all times
- Care: Clean with a soft, dry cloth. In case of larger stains, carefully rub with a slightly damp, non-abrasive sponge
- Do not jump on the bed

Français

IMPORTANT ! CONSERVER POUR RÉFÉRENCE ULTÉRIEURE : LIRE ATTENTIVEMENT

- Le montage doit être effectué par un adulte. Le montage doit être vérifié par un adulte avant utilisation
- ATTENTION ! Tenir les vis, les petites pièces et les sachets en plastique hors de portée des enfants
- Identifiez correctement toutes les pièces avant de les assembler
- N'utilisez jamais votre article si l'une de ses pièces est cassée ou manquante
- En cas de problème, veuillez contacter notre service après-vente
- Les instructions du fabricant doivent être respectées à tout moment
- Entretien : nettoyer avec un chiffon doux et sec. En cas de taches plus importantes, frotter soigneusement avec une éponge non abrasive légèrement humide. légèrement humide et non abrasive
- Ne pas sauter sur le lit

Deutsch

WICHTIG ! ZUM SPÄTEREN NACHSCHLAGEN AUFBEWAHREN: SORGFÄLTIG LESEN

- Muss von einem Erwachsenen zusammengebaut werden. Der Zusammenbau muss vor dem Gebrauch von einem Erwachsenen überprüft werden
- WARNUNG! Bewahren Sie alle Schrauben, Kleinteile und Plastikbeutel außerhalb der Reichweite von Kindern auf
- Kennzeichnen Sie vor dem Zusammenbau alle Teile richtig.
- Benutzen Sie Ihren Artikel niemals, wenn Teile gebrochen sind oder fehlen
- Sollten Probleme auftreten, wenden Sie sich bitte an unseren Kundendienst
- Die Anweisungen des Herstellers sind stets zu befolgen
- Pflege: Mit einem weichen, trockenen Tuch reinigen. Bei größeren Flecken vorsichtig mit einem leicht feuchten, nicht scheuernden Schwamm abreiben. nicht scheuernden Schwamm
- Nicht auf das Bett springen

💡 More Tips 💡

1

English - Before installation, you can place the parts on a carpet or other soft fabric, in order to avoid damaging your floor.

Français - Avant l'installation, vous pouvez placer les pièces sur un tapis ou un autre tissu doux, afin d'éviter d'endommager votre sol.

Deutsch - Vor der Installation können Sie die Teile auf einen Teppich oder ein anderes weiches Material legen, um eine Beschädigung Ihres Fußbodens zu vermeiden.

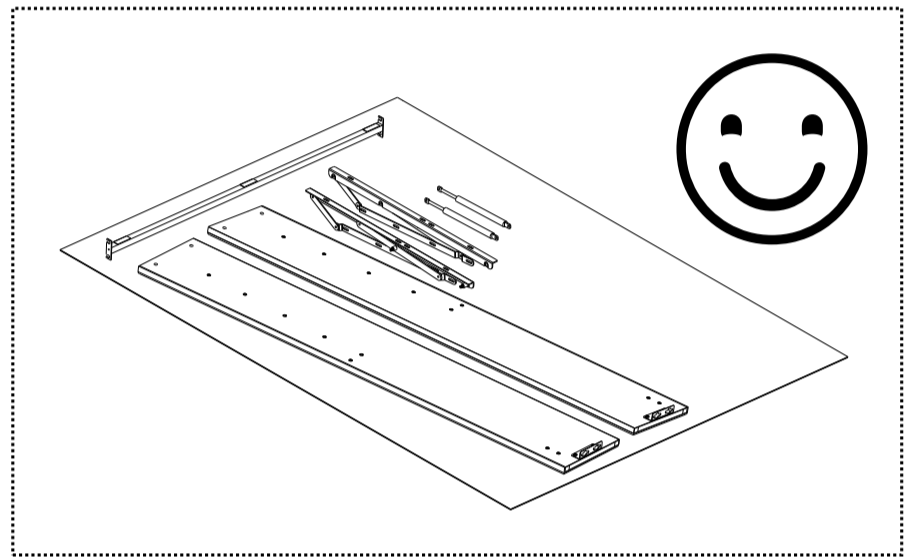
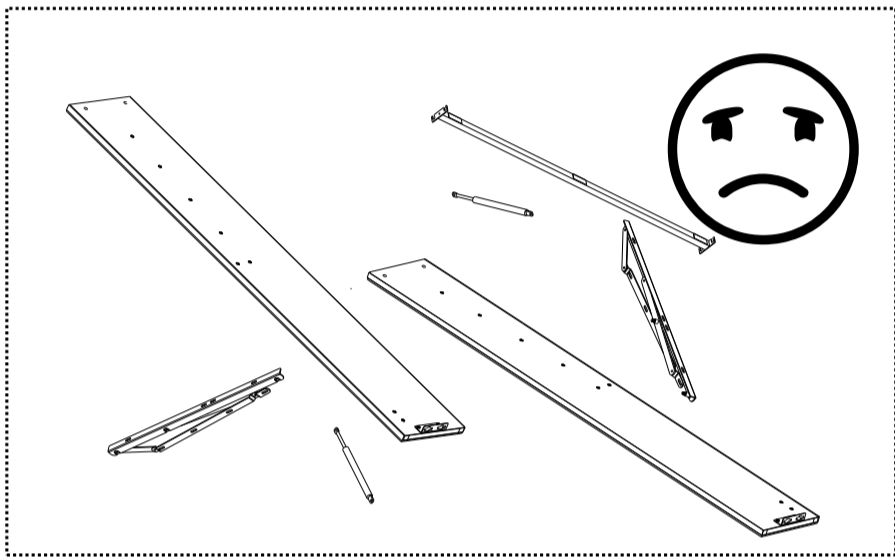

2

English - For your and your family's safety, please do not jump on beds, especially with hydraulic structures. When need to move bed, please work with more than one person to lift, not push, to avoid scratching your floor and hurting the stability of the bed.

Français - Pour votre sécurité et celle de votre famille, ne sautez pas sur les lits, en particulier sur les structures hydrauliques. Lorsqu'il est nécessaire de déplacer le lit, il est préférable de travailler à plusieurs pour le soulever, et non pour le pousser, afin d'éviter de rayer le sol et de nuire à la stabilité du lit.



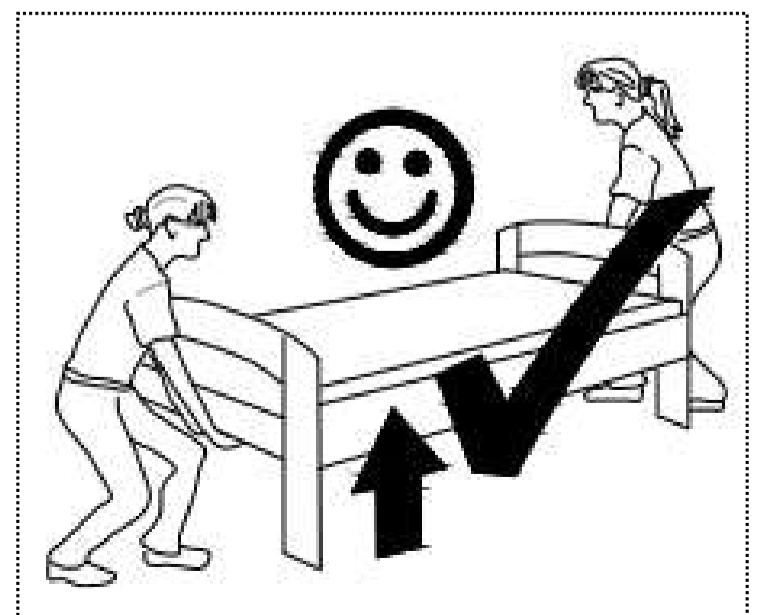

Deutsch - Zu Ihrer Sicherheit und der Ihrer Familie sollten Sie nicht auf Betten springen, insbesondere bei hydraulischen Konstruktionen. Wenn Sie das Bett bewegen müssen, heben Sie es bitte mit mehreren Personen an und schieben Sie es nicht, um den Boden nicht zu verkratzen und die Stabilität des Bettes nicht zu beeinträchtigen.

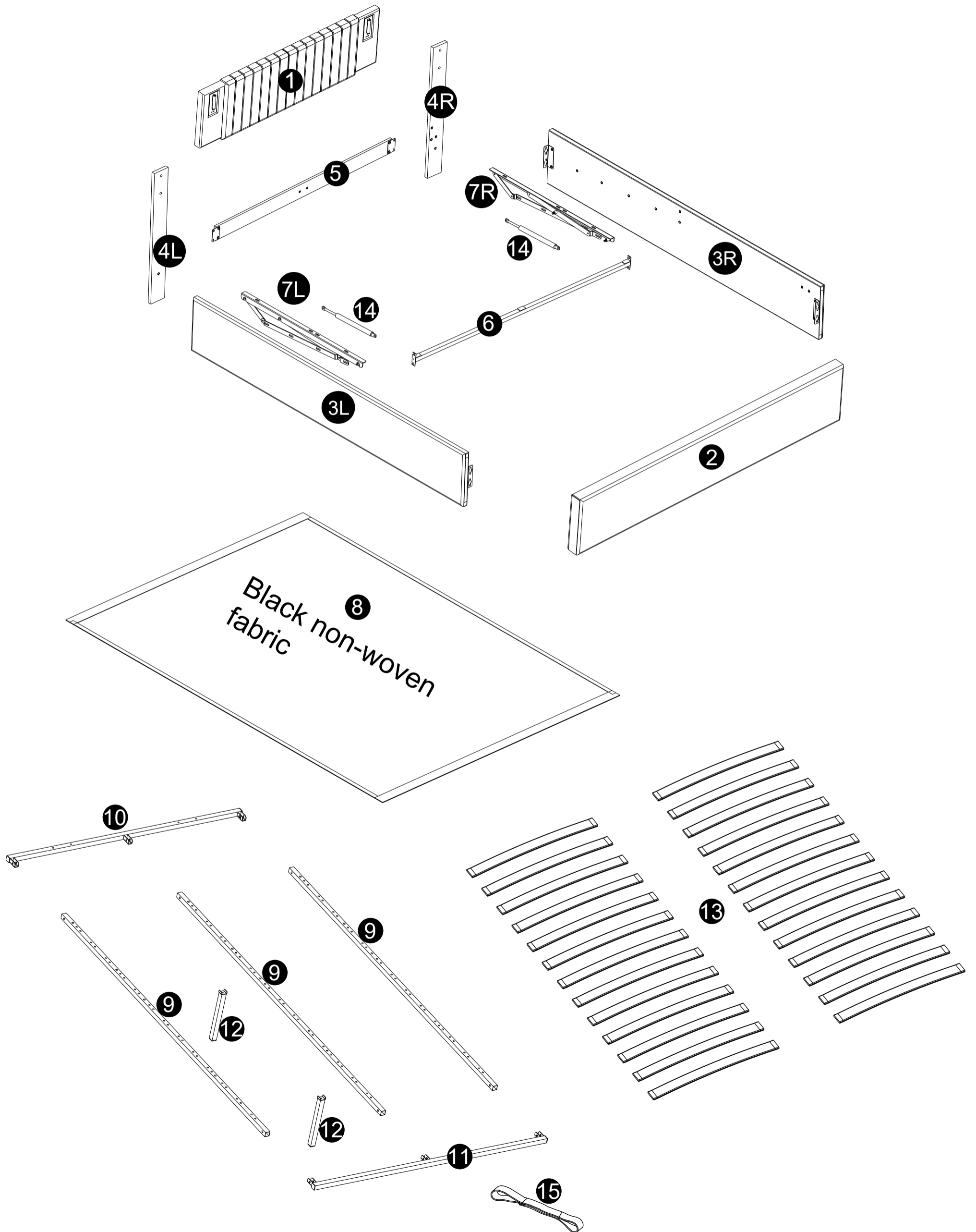

Stückliste

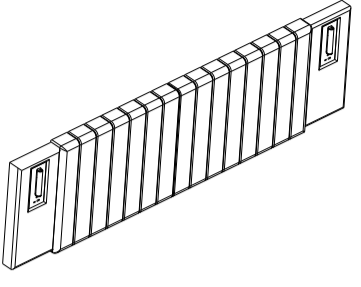
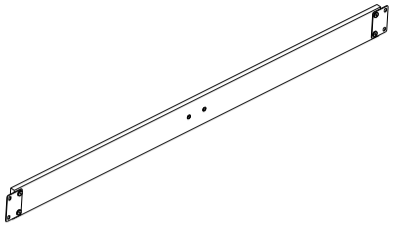
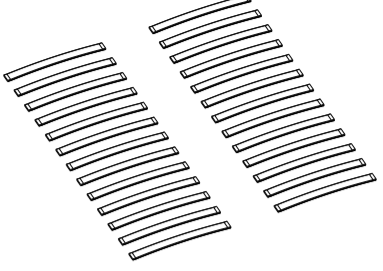

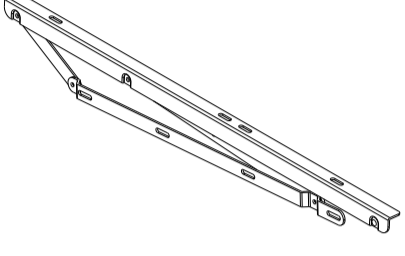
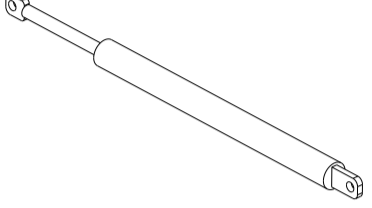
WF531487/WF531489/WF531491

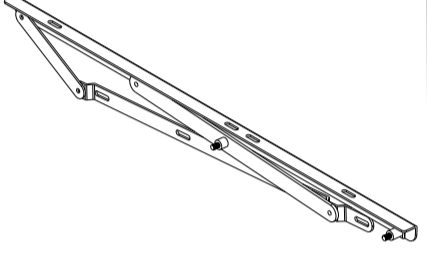

1		X1	5		X1	13		X1
4L		X1	7L		X1	14		X2
4R		X1	7R		X1			

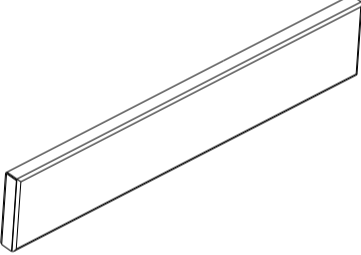
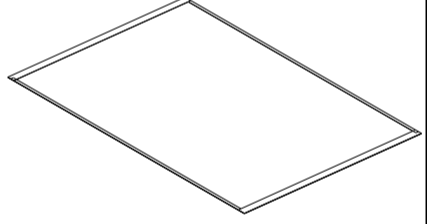
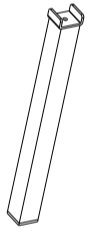
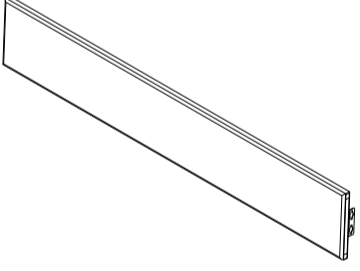
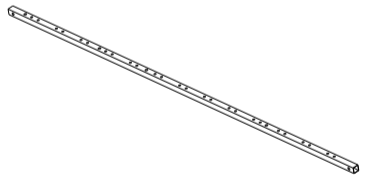
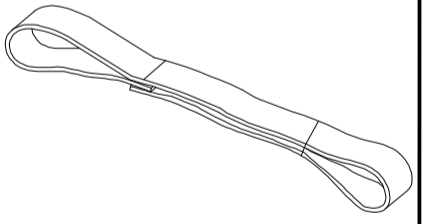
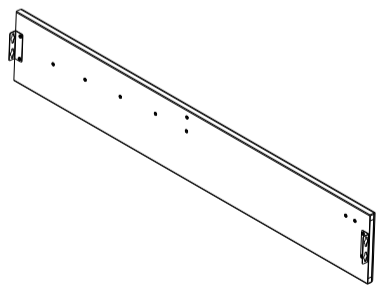
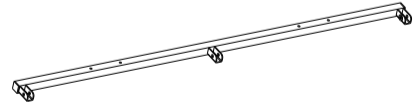
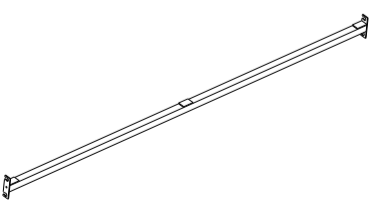
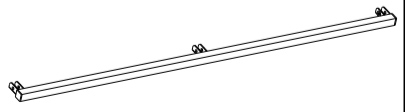

WF531488/WF531490/WF531492

2		X1	8		X1	12		X2
3L		X1	9		X3	15		X1
3R		X1	10		X1			
6		X1	11		X1			

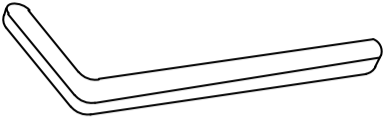
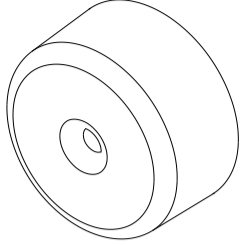
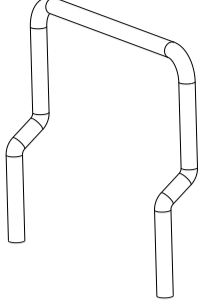
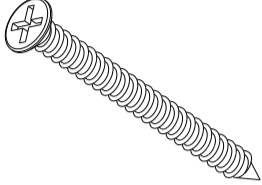
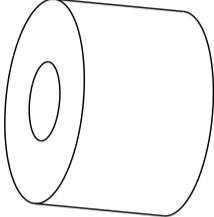
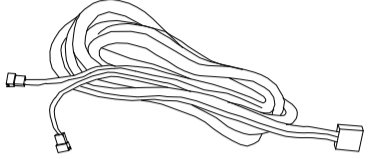
Hardware List-Hardware-Liste-Liste du matériel

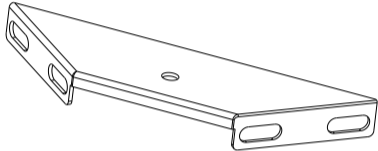
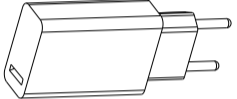
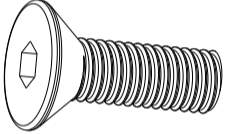
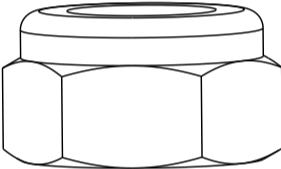
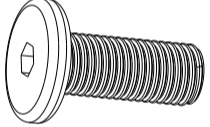
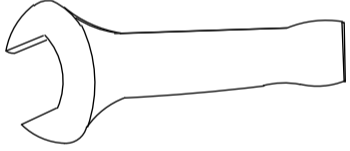
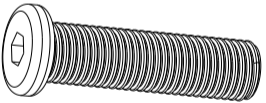
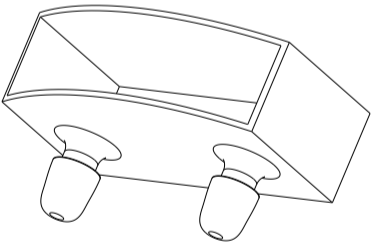
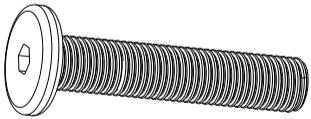
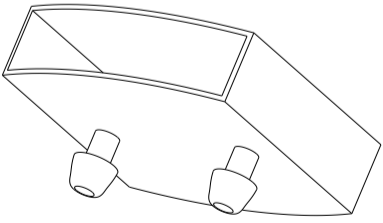
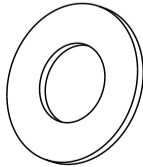
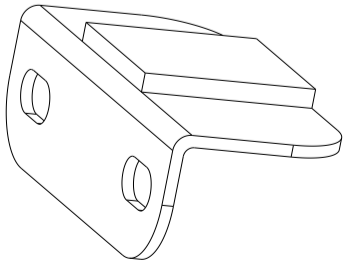

WF531487/WF531489/WF531491

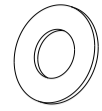
A		X1	J		X2	S		X2
B	 M4x40mm	X2	K		X8	T		X1
C	 M6x35mm	X2	L		X2	U		X1
D	 M8x18mm	X4	M	 M8	X16			
E	 M8x20mm	X24	N		X1			
F	 M8x30mm	X8	P		X26			
G	 M8x40mm	X16	Q		X13			
H		X12	R		X2			

1	A x 1	G x 4	H x 4
		 M8 x 40mm	

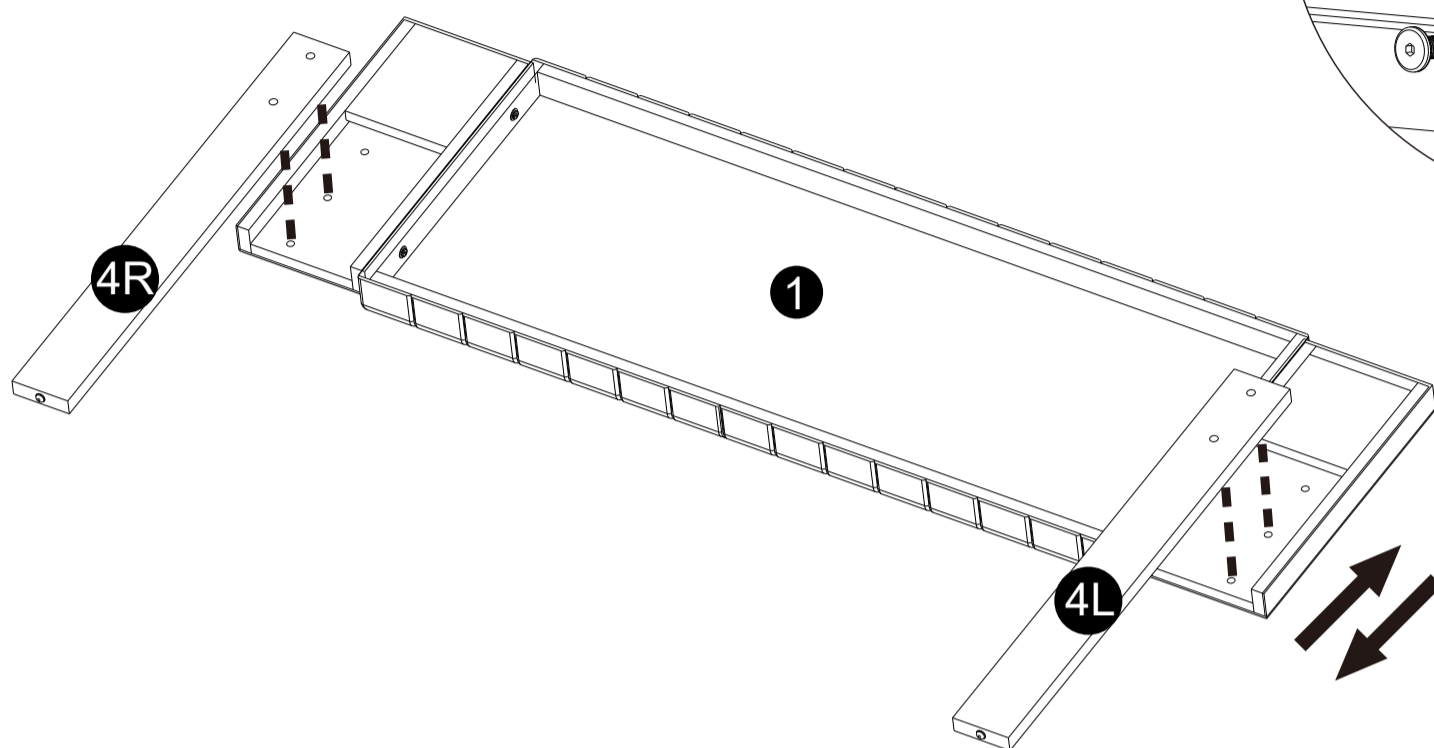
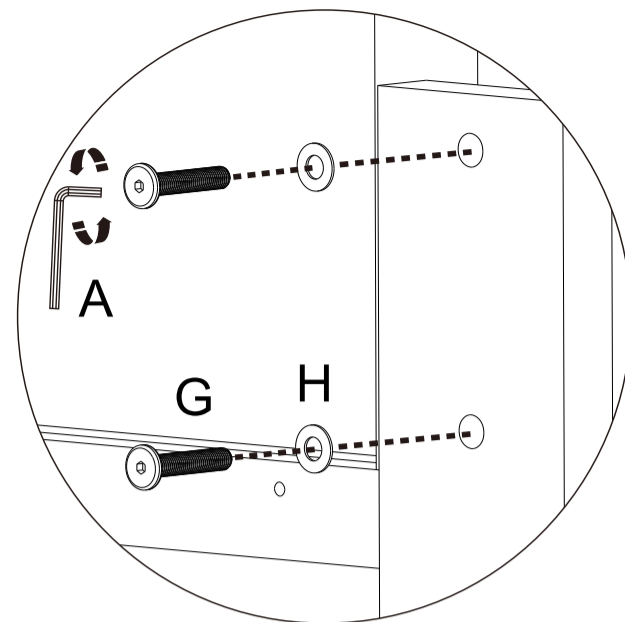
Headboard height is adjustable
 Kopfteil ist Höhe-einstellbar
 La hauteur de la tête de lit est réglable



2	A x 1	E x 4
		 M8 x 20mm

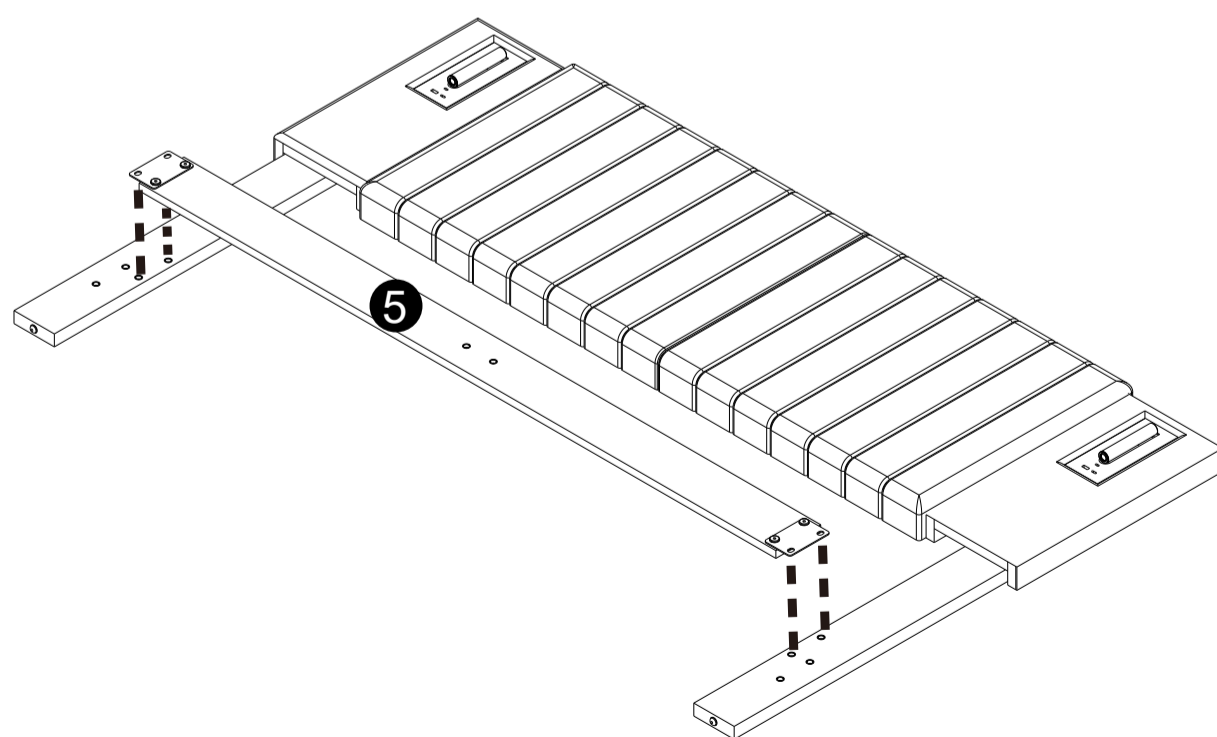
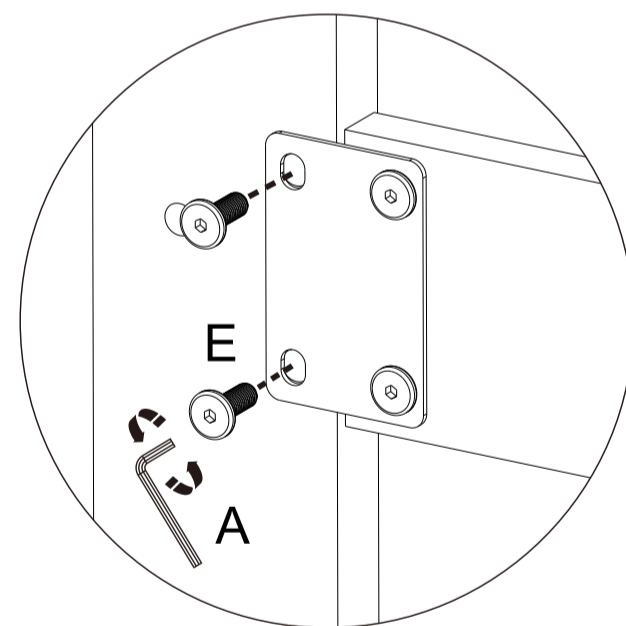

3

A x 1



B x 2



M4 x 40mm

E x 4



M8 x 20mm

J x 2



R x 2

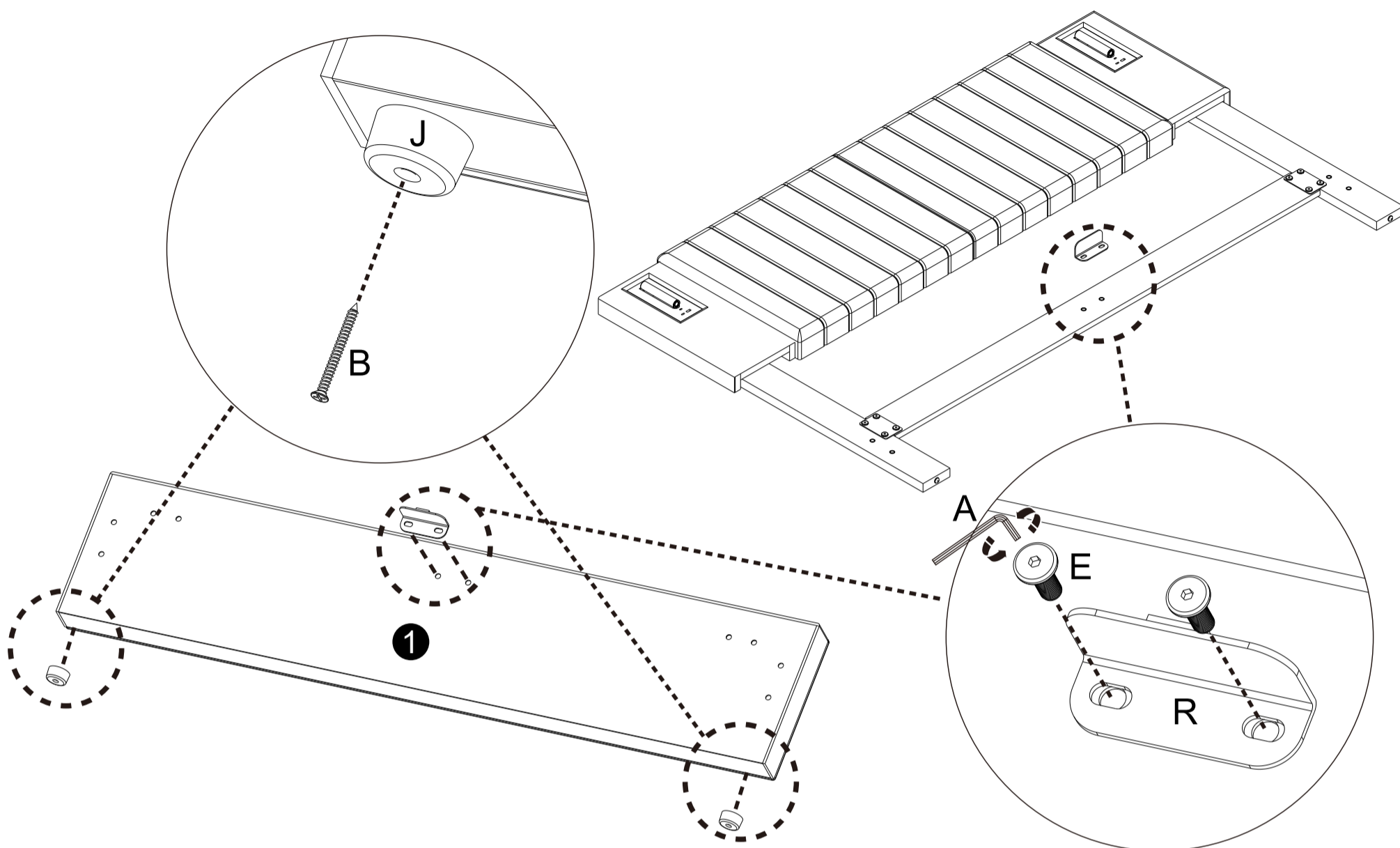
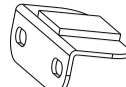

4

A x 1





E x 8

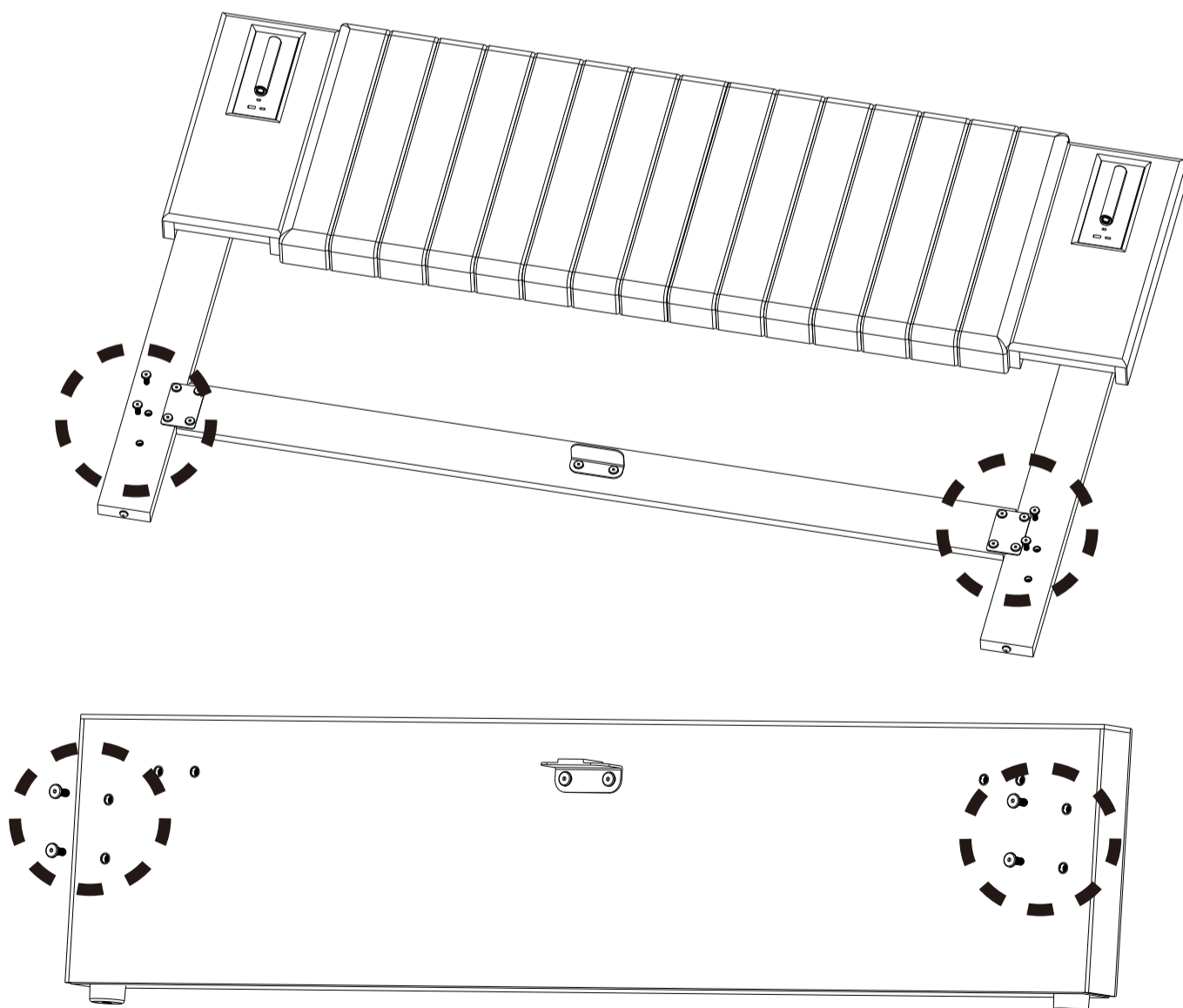
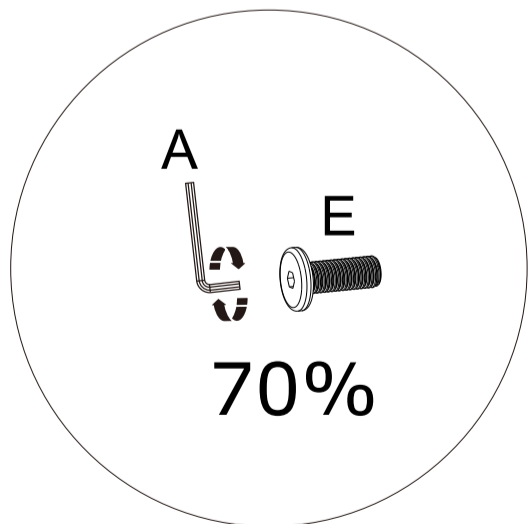

M8 x 20mm



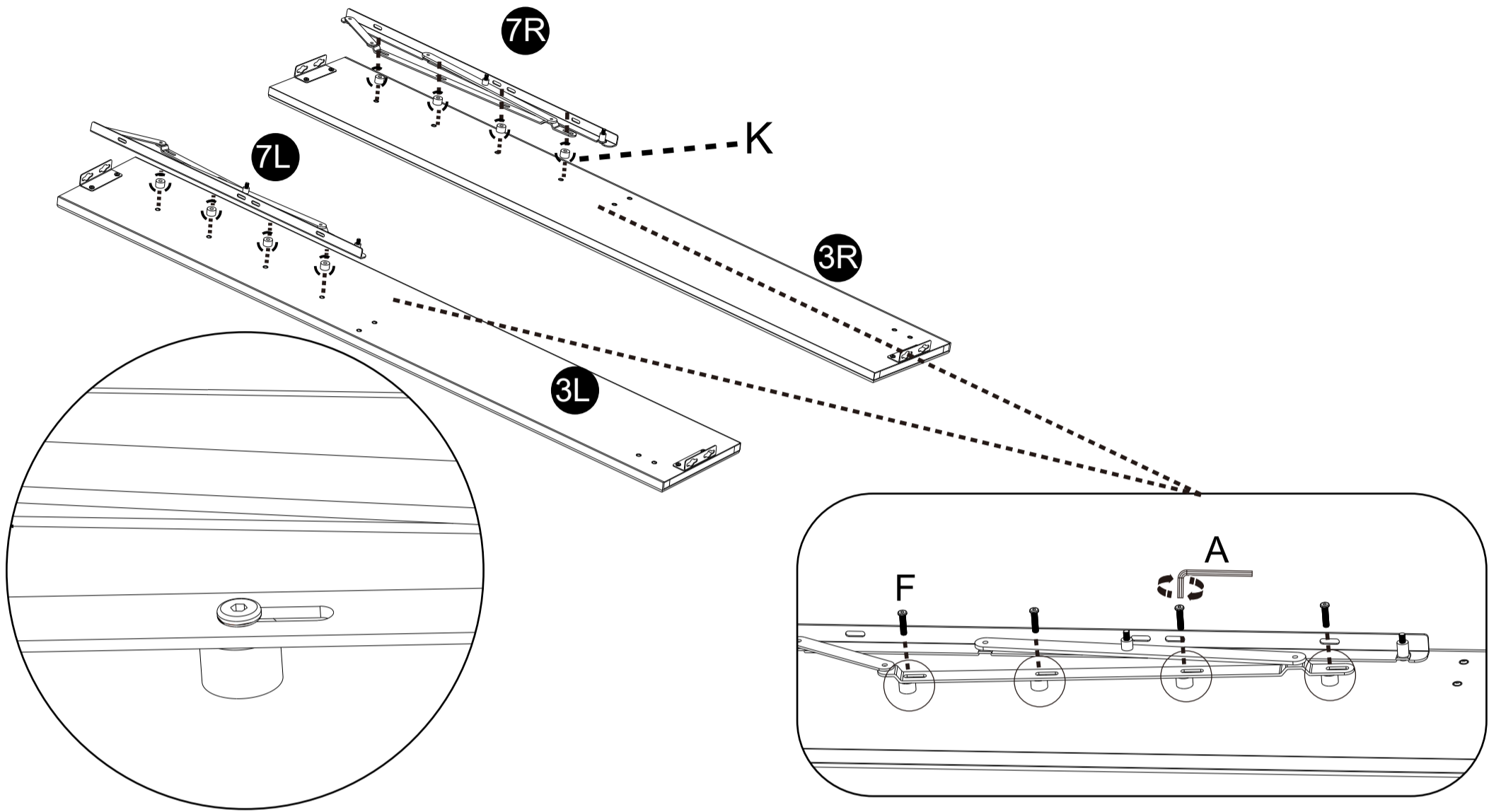

5	A x 1	F x 8	K x 8
		 M8 x 30mm	



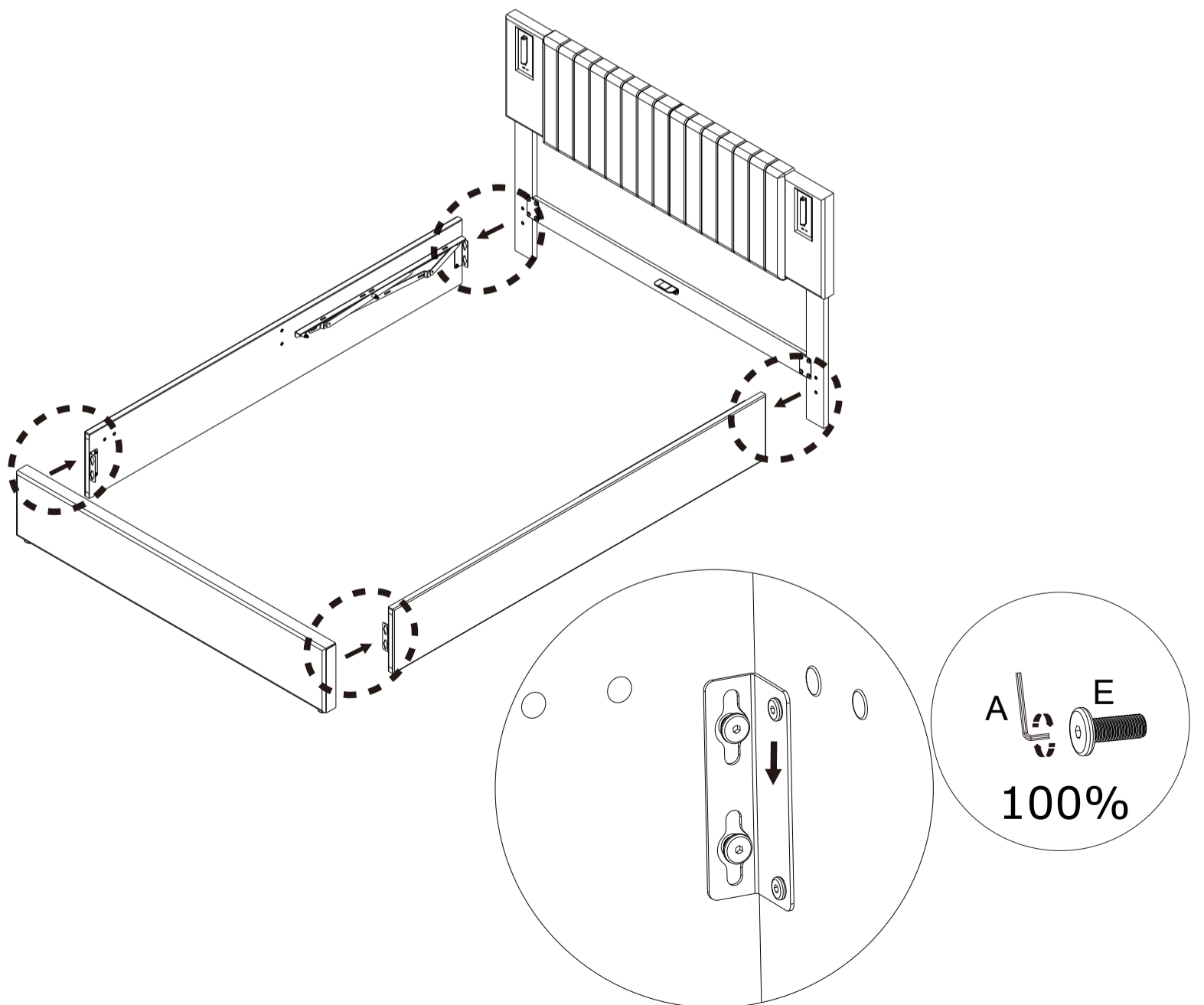

6	A x 1
	

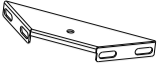

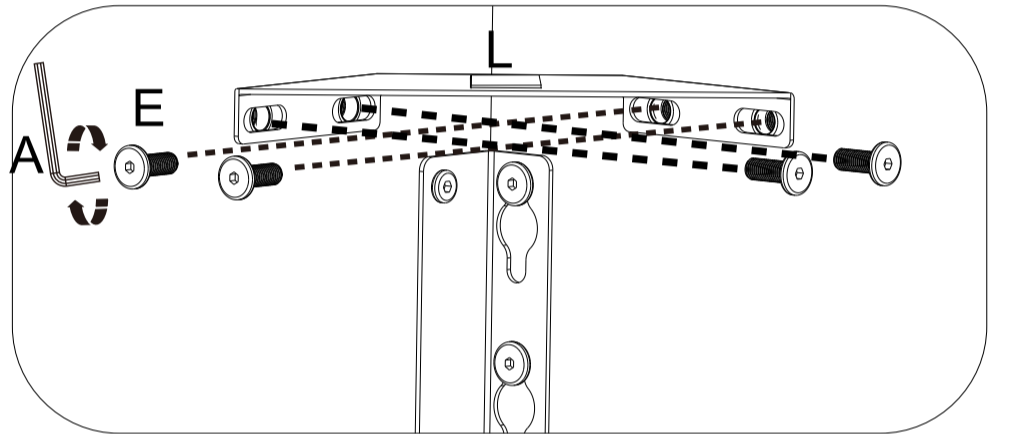
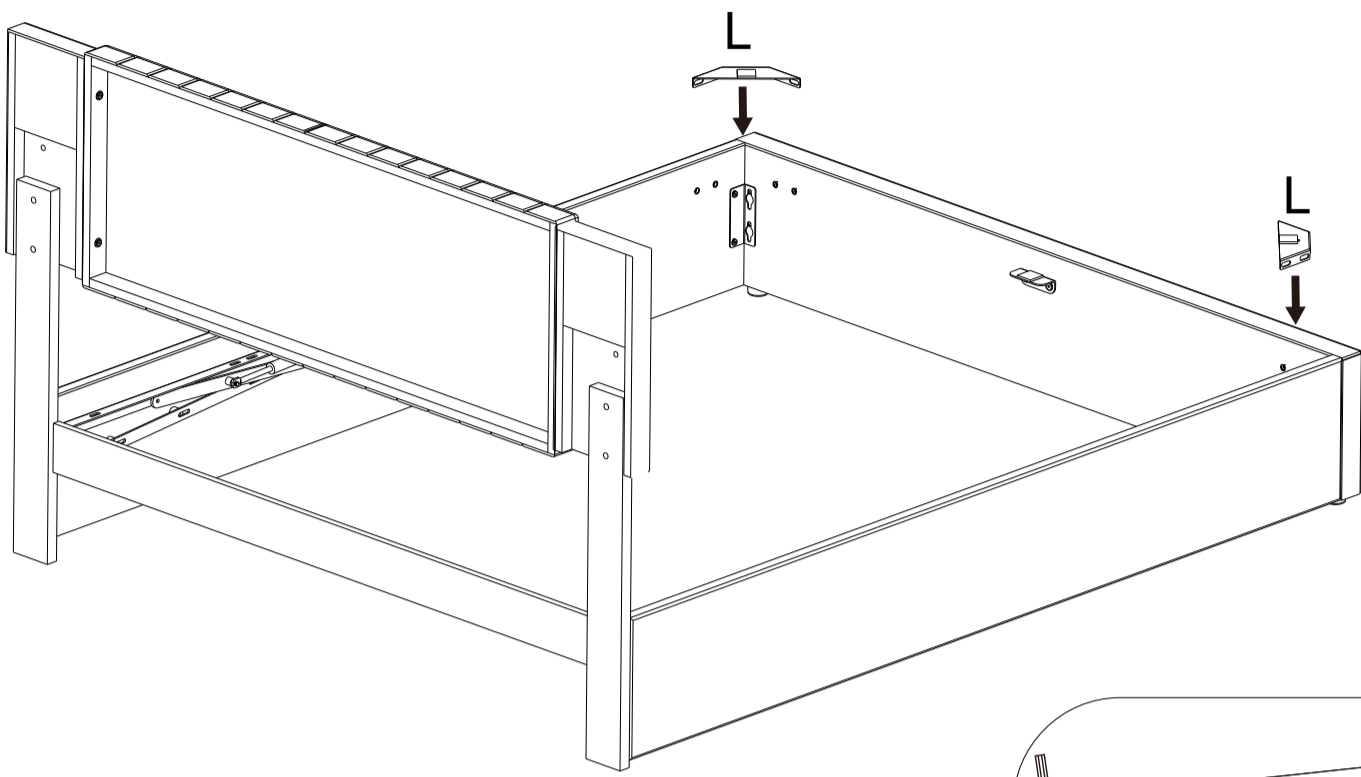
7	A x 1	E x 8	L x 2
		 M8 x 20mm	



8	A x 1	D x 4
		 M8 x 18mm

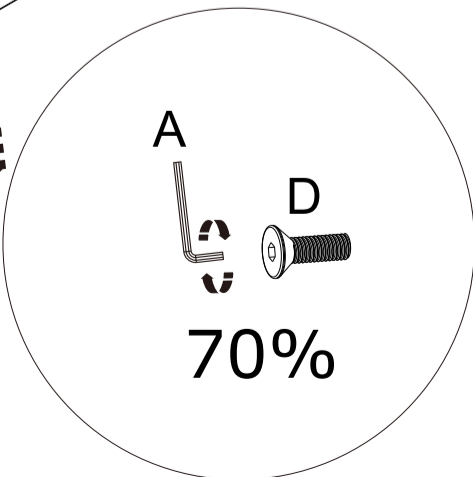
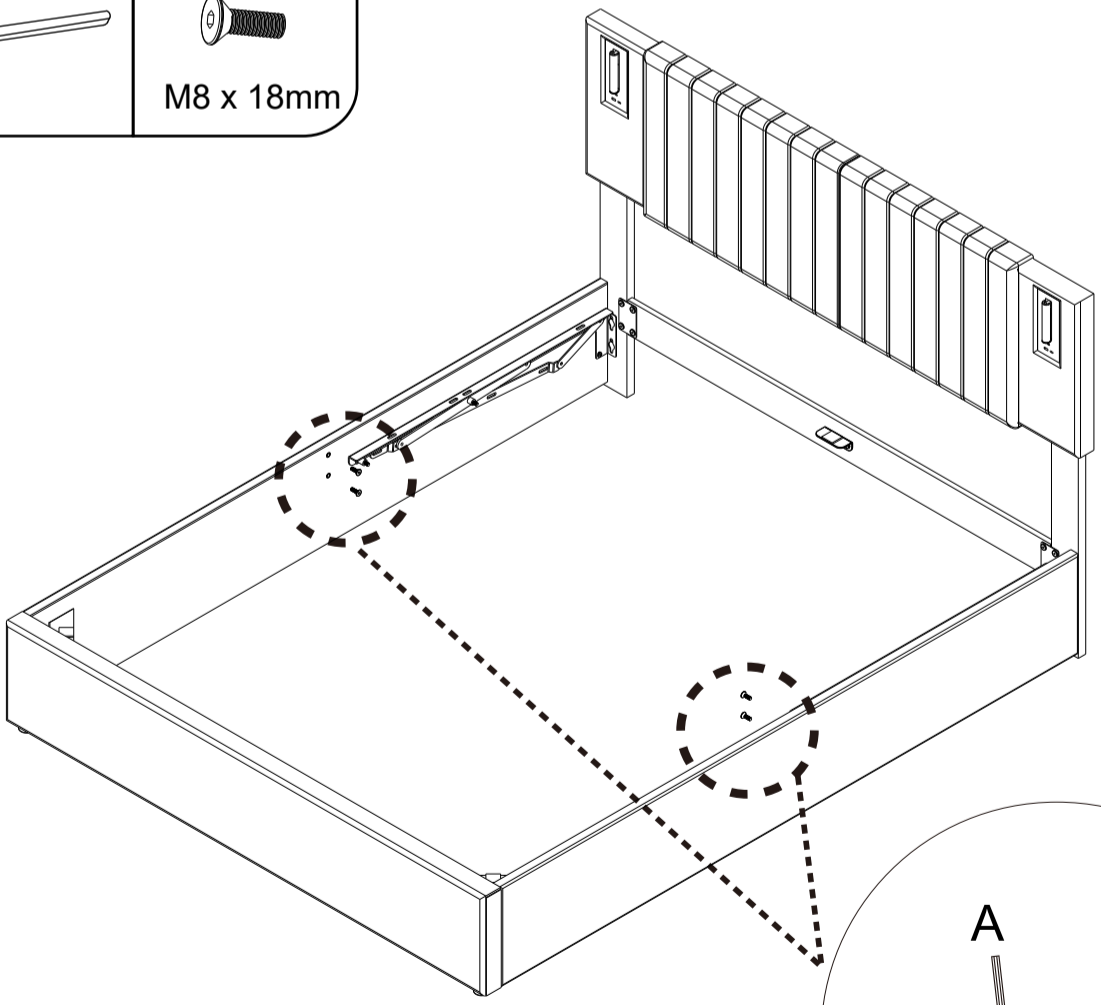

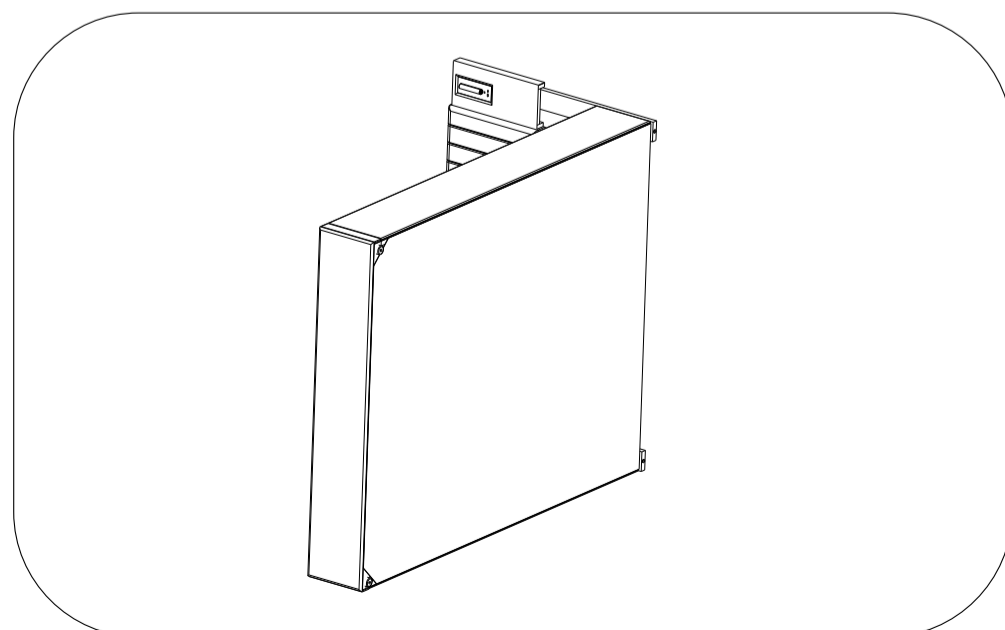
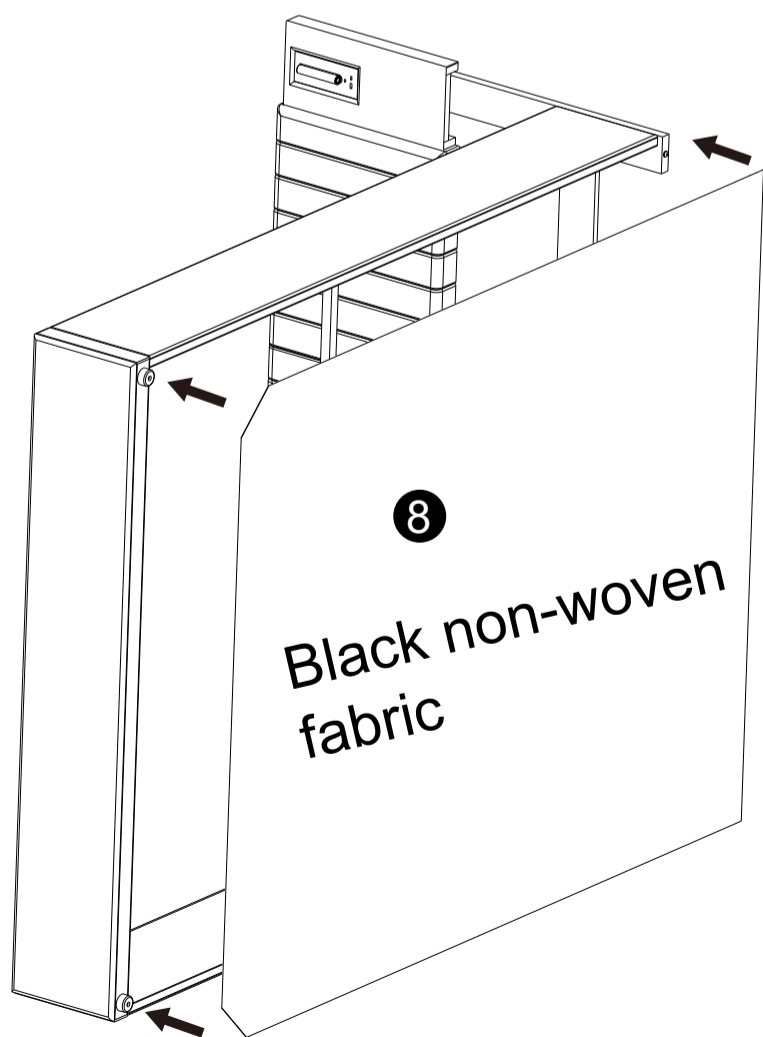
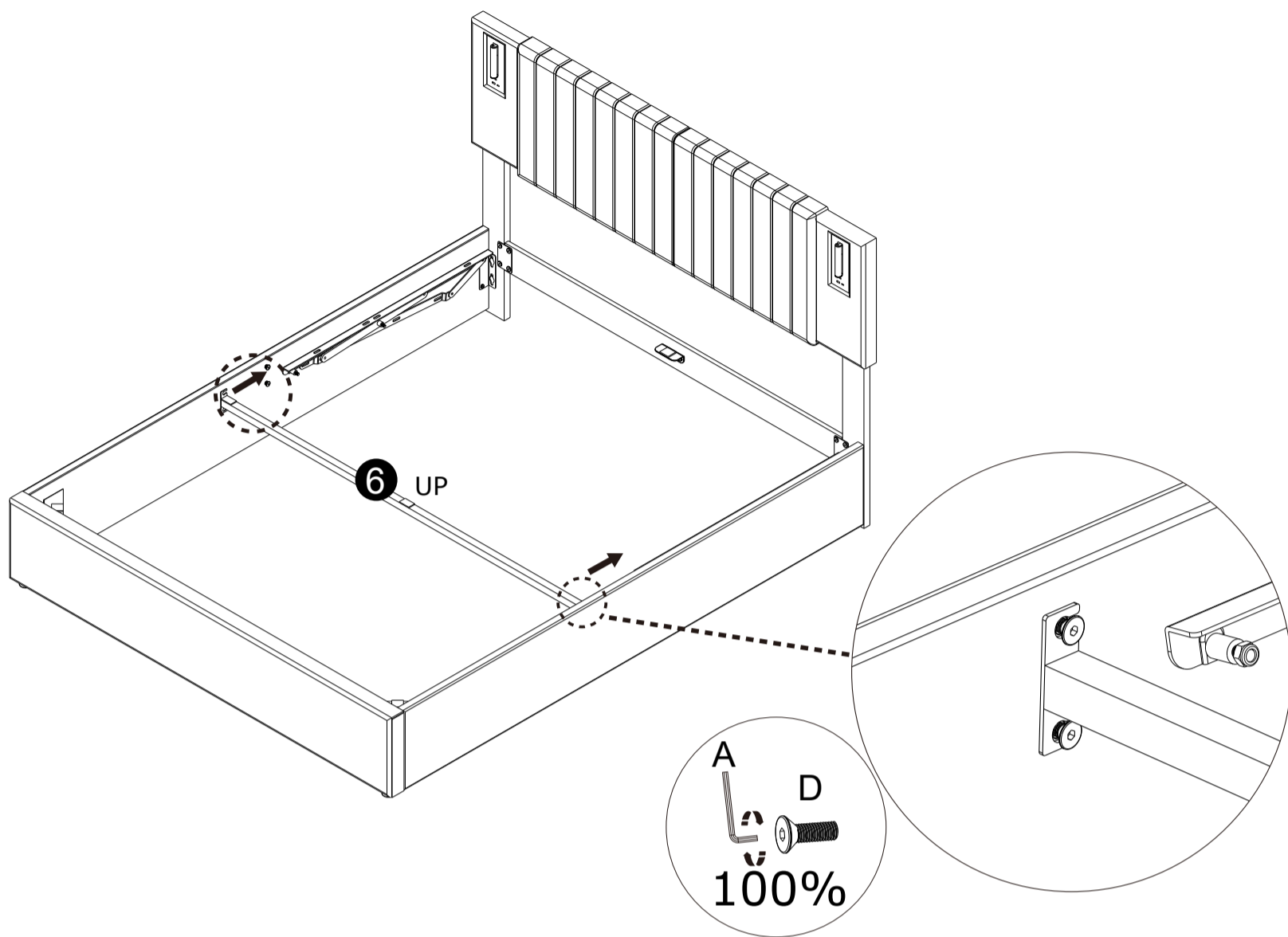
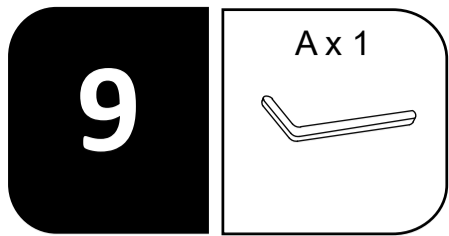

11

A x 1



G x 6



M8 x 40mm

H x 6

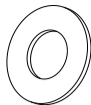

M x 6

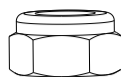

N x 1



!!! Please aware the orientation of the holes on #9
!!!Bitte beachten Sie die Ausrichtung der Löcher auf #9
!!! Attention à l'orientation des trous sur le #9

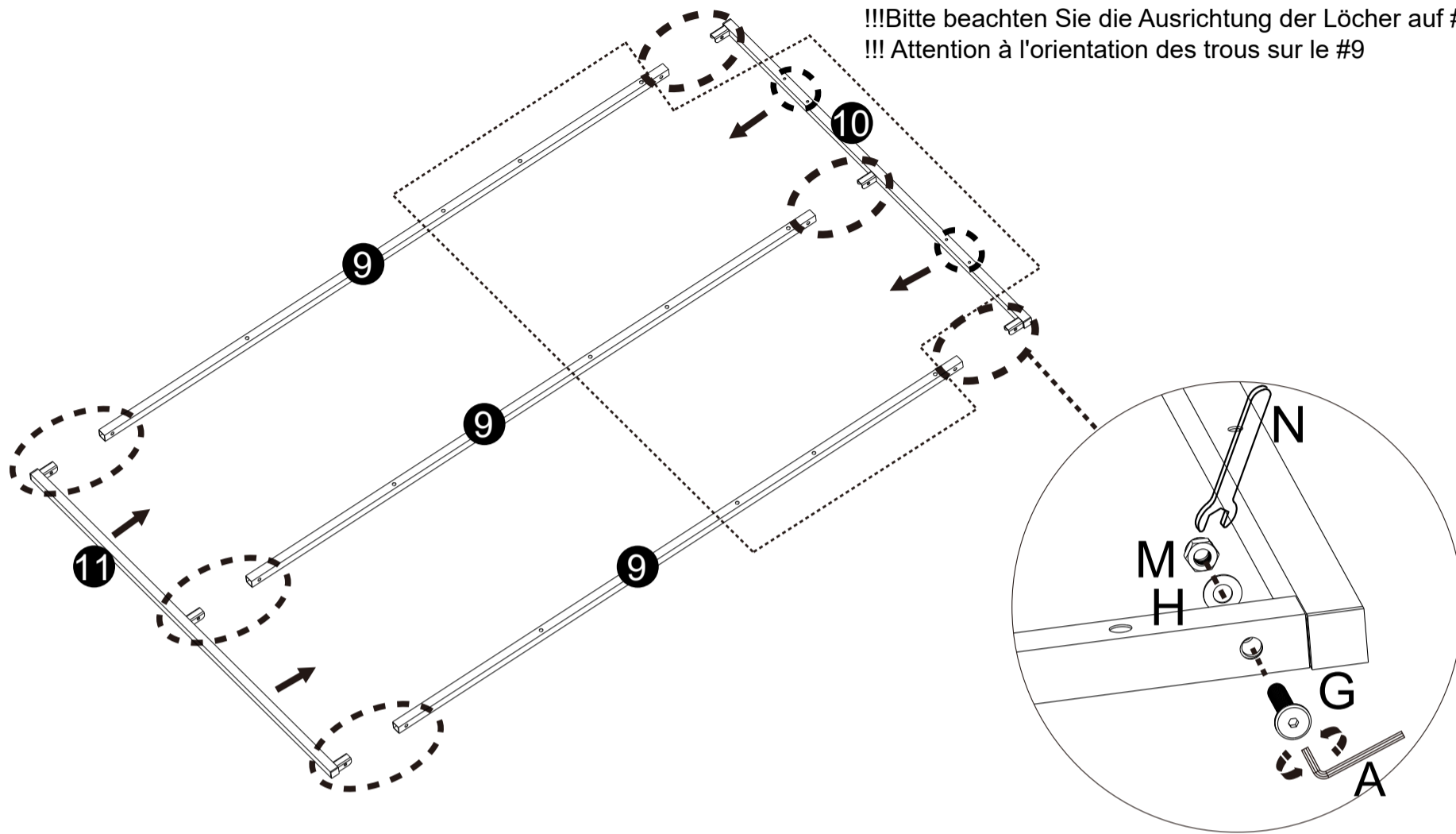

12

A x 1



C x 2



M6 x 35mm

H x 2

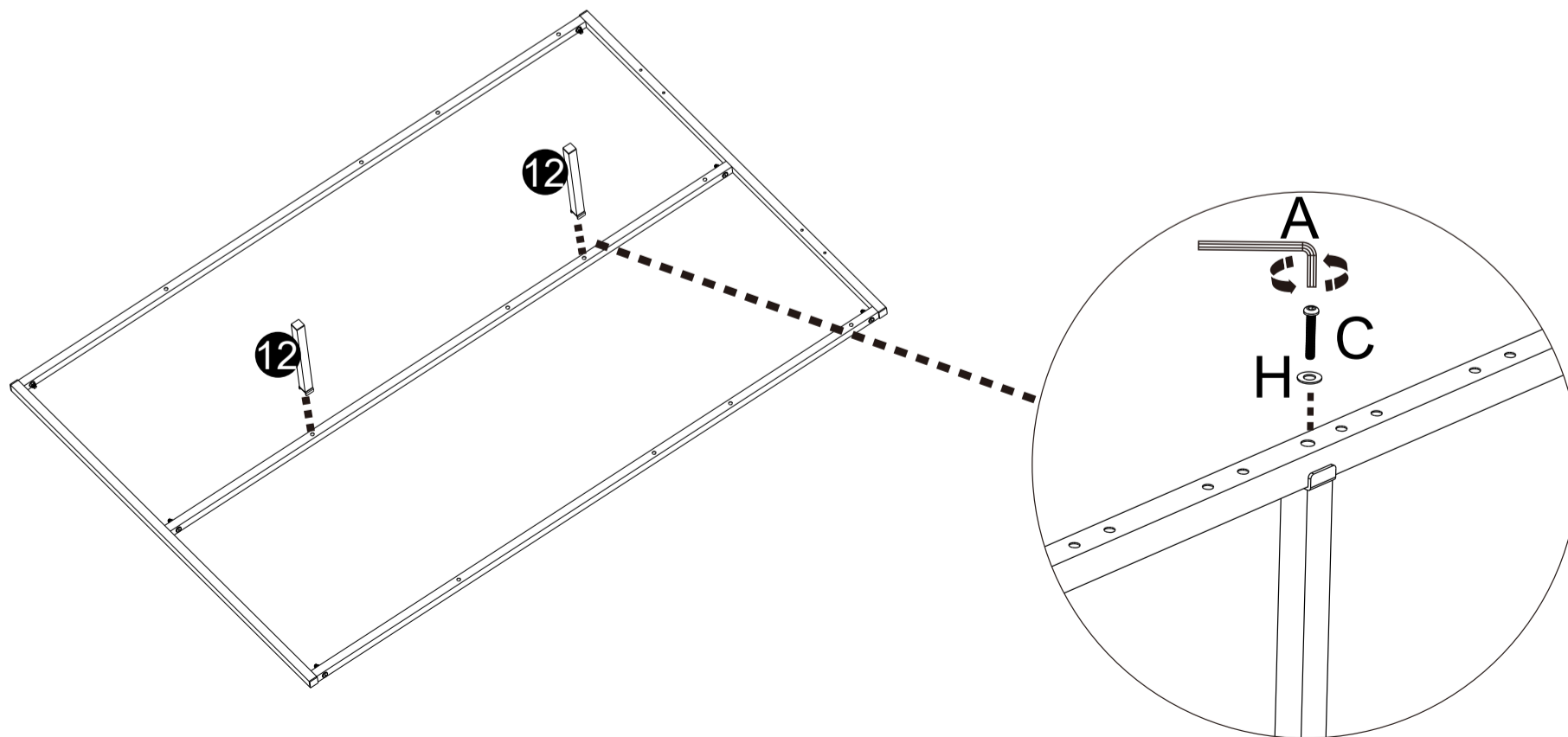

13

A x 1



G x 6



M8 x 40mm

M x 6

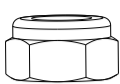

N x 1

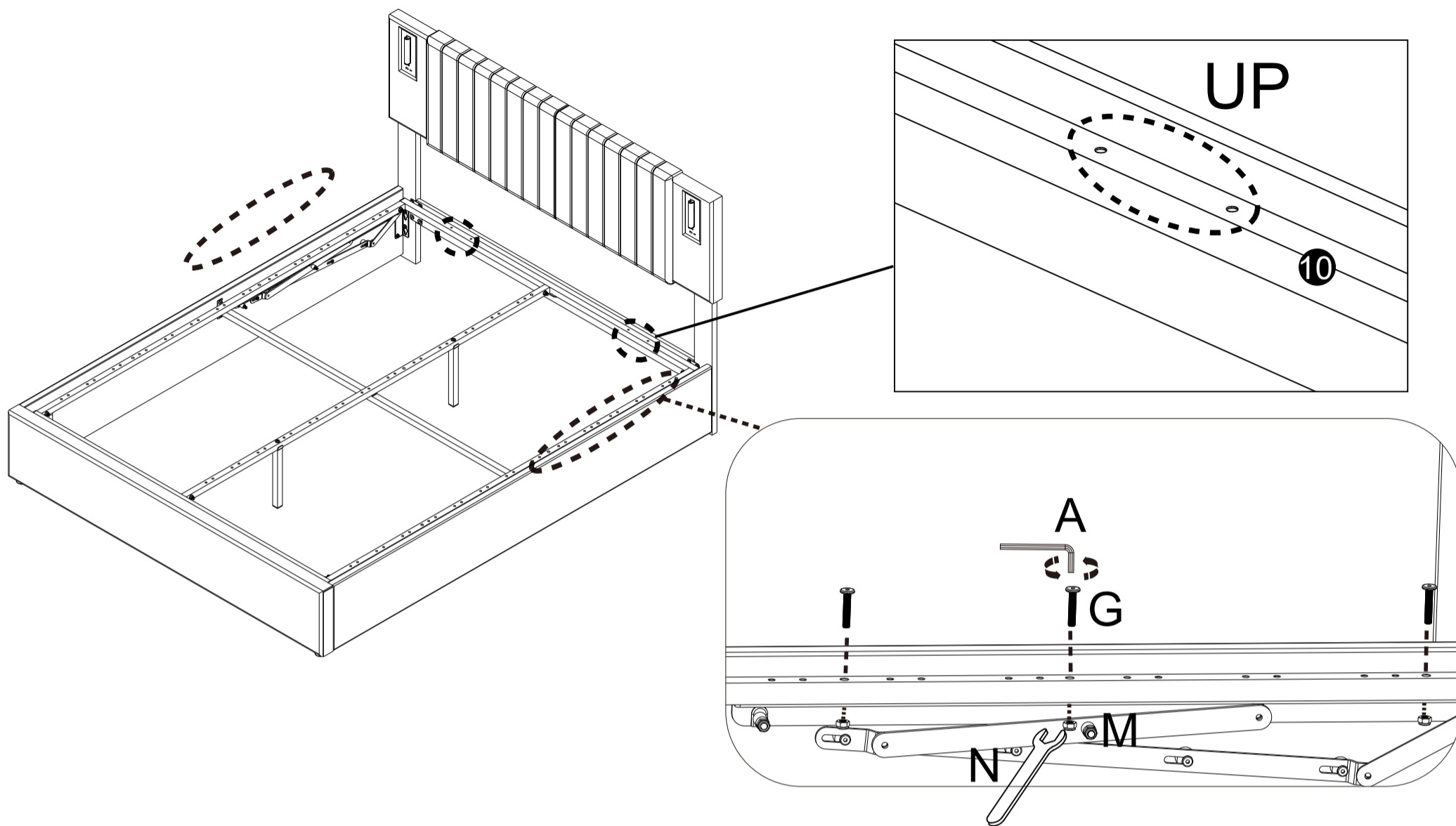

14

S x 2

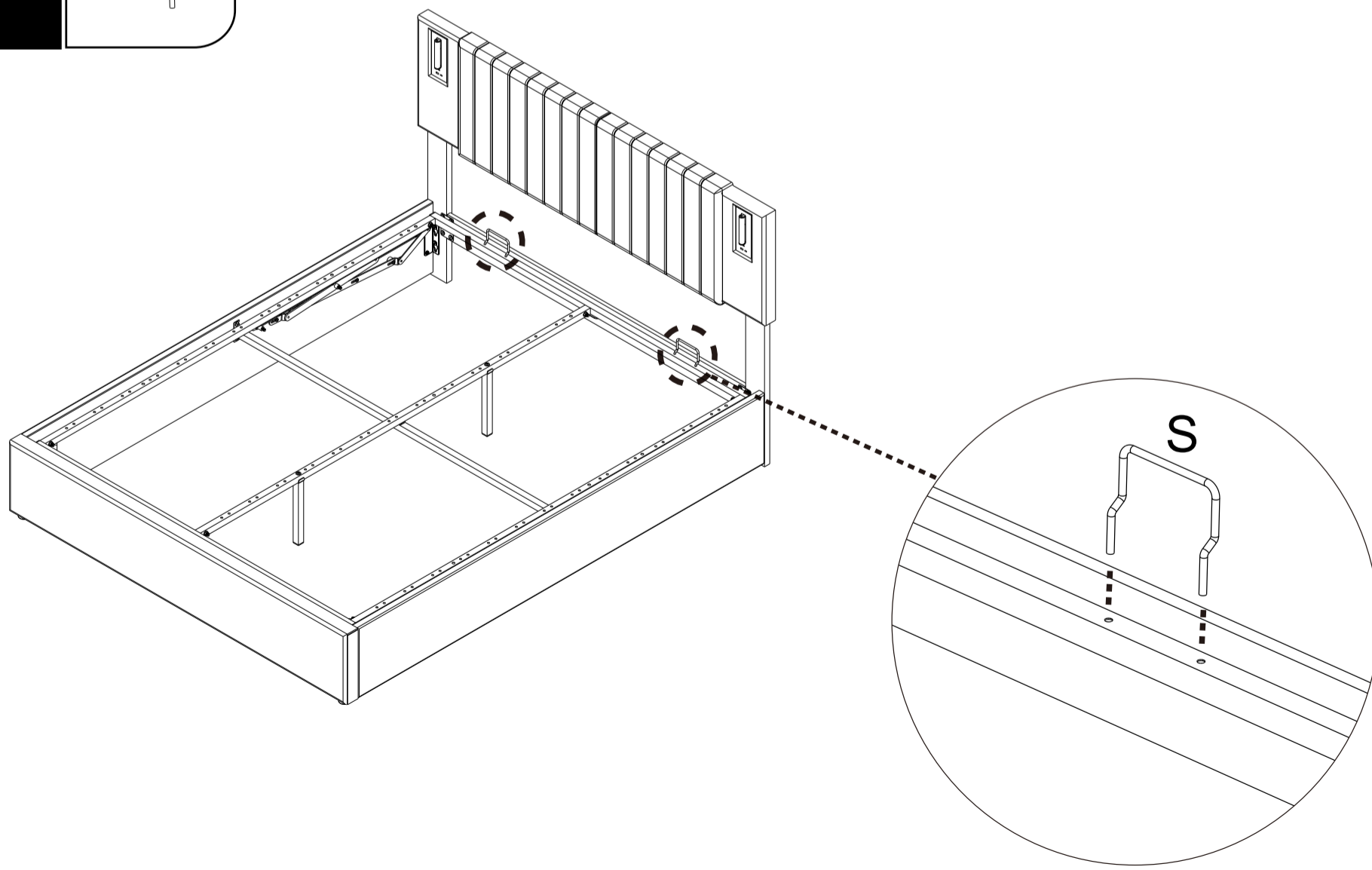
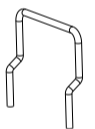

15	P x 26	Q x 13

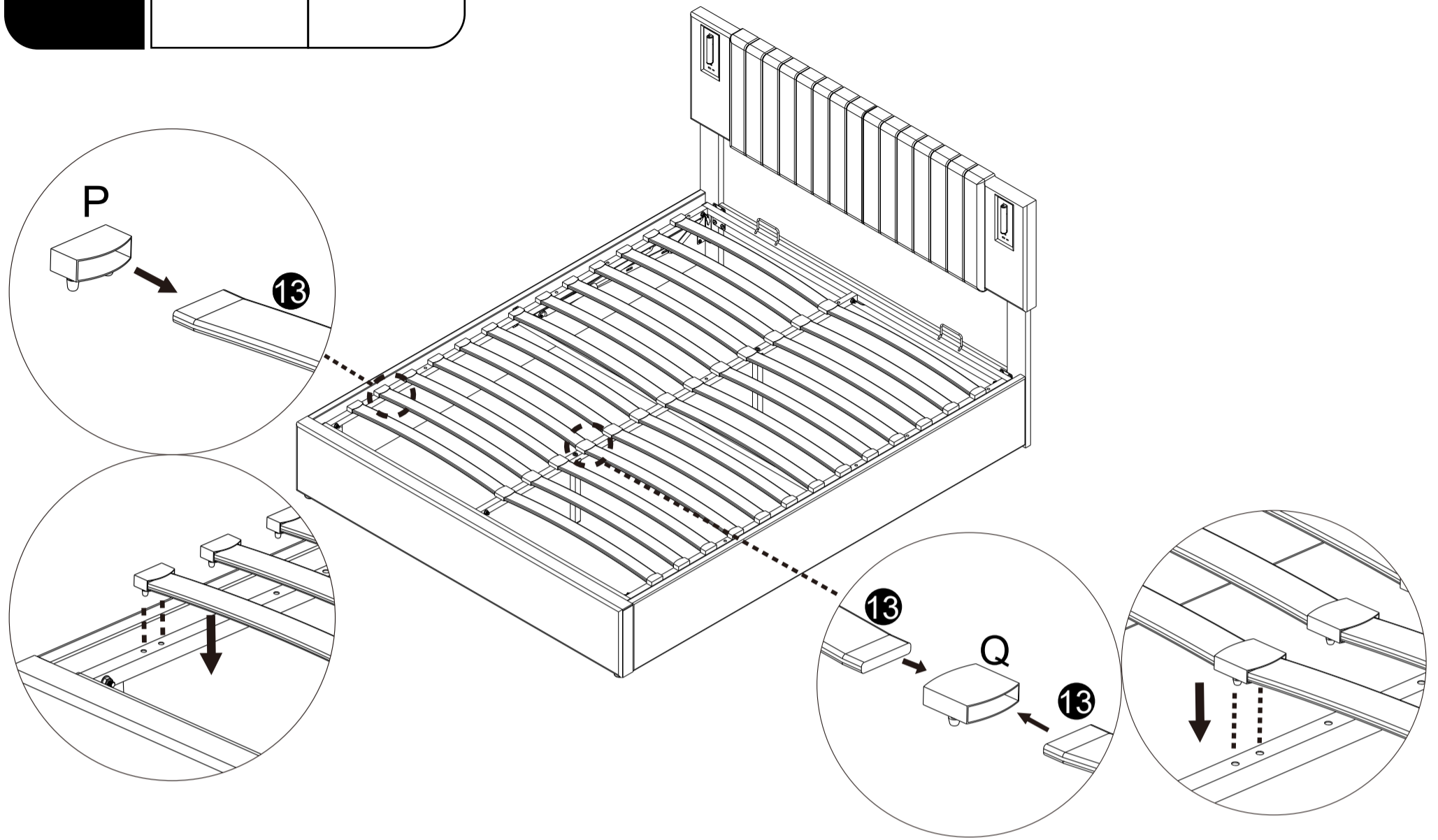

16	M x 4	N x 1

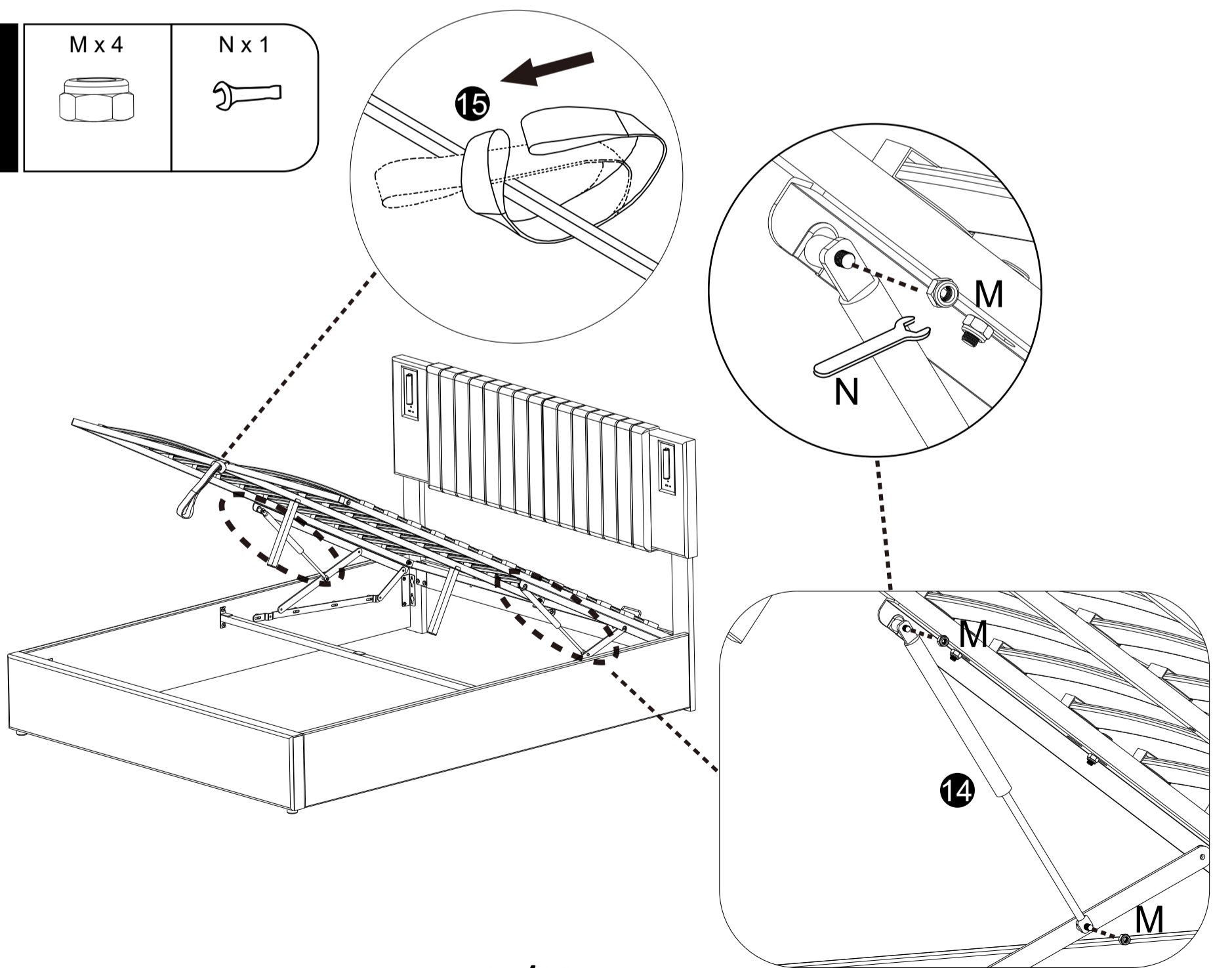

17

WHY WON'T MY HYDRAULIC BED STAY DOWN?

1. In fact, nine times out ten the reason why hydraulic won't close is because you need to put your mattress on top of the bed. Yep, it really is that easy. This is because the hydraulic pistons need the weight of the mattress to provide enough pressure to close your bed.

2. However, what if you've put your mattress on your bed and you're one of the unlucky ones who finds that their hydraulic bed still won't stay down?

As previously mentioned, they require pressure in order to close. However, occasionally as well as placing the mattress on the bed you will initially have to apply some physical force yourself to close the bed. Don't worry you won't break it!!!

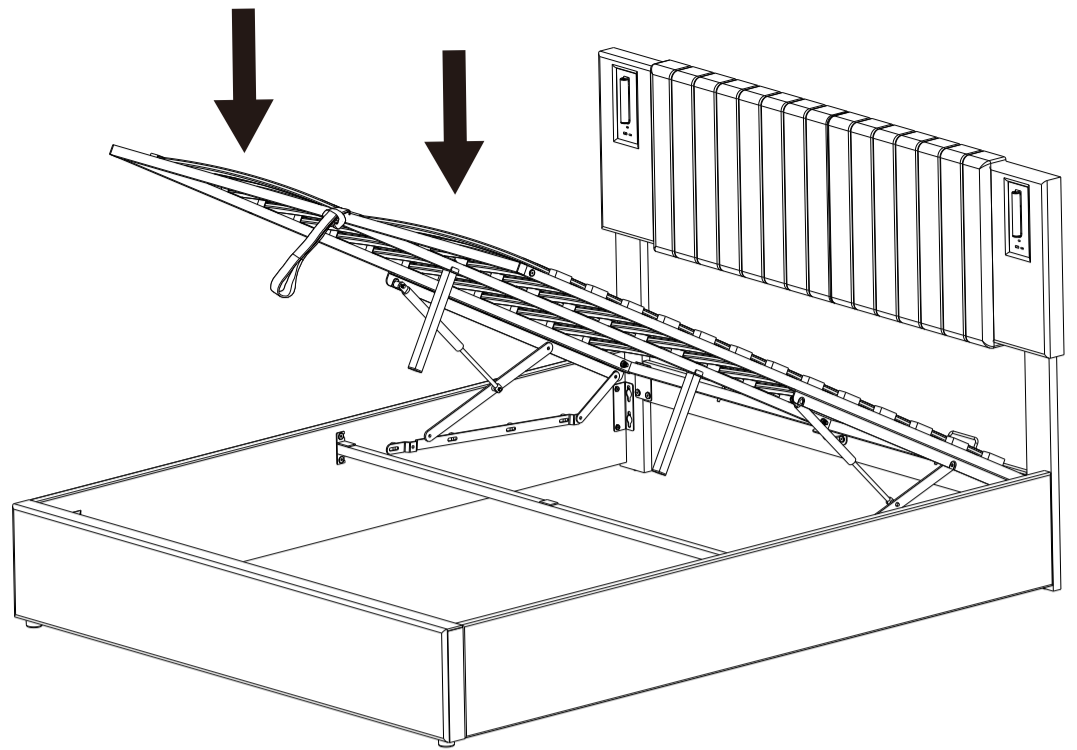

WARUM BLEIBT MEIN HYDRAULISCHES BETT NICHT UNTEN?

1. In neun von zehn Fällen liegt der Grund dafür, dass sich die Hydraulik nicht schließen lässt, darin, dass Sie Ihre Matratze oben auf das Bett legen müssen. Ja, es ist wirklich so einfach. Das liegt daran, dass die Hydraulikkolben das Gewicht der Matratze benötigen, um genügend Druck zum Schließen des Bettes zu erzeugen.

2. Was aber, wenn Sie Ihre Matratze auf Ihr Bett gelegt haben und zu den Unglücklichen gehören, die feststellen, dass ihr hydraulisches Bett trotzdem nicht unten bleibt?

Wie bereits erwähnt, muss man Druck ausüben, um sie zu schließen. Gelegentlich müssen Sie jedoch nicht nur die Matratze auf das Bett legen, sondern zunächst selbst etwas Kraft aufwenden, um das Bett zu schließen. Keine Sorge, Sie werden es nicht kaputt machen!!!

POURQUOI MON LIT HYDRAULIQUE NE RESTERA-T-IL PAS EN BAS ?

1. En fait, neuf fois sur dix, la raison pour laquelle le système hydraulique ne ferme pas, c'est parce que vous devez mettre votre matelas au dessus du lit. Oui, c'est vraiment aussi simple que cela. Ceci est dû au fait les pistons hydrauliques ont besoin du poids du matelas pour fournissent suffisamment de pression pour fermer votre lit.

2. Mais que se passe-t-il si vous posez votre matelas sur votre lit ?

et tu fais partie des malchanceux qui trouvent ça le lit hydraulique ne reste toujours pas baissé ?

Comme mentionné précédemment, ils nécessitent des pressions pour fermer. Cependant, de temps en temps, en plus de placer le matelas sur le lit, vous devrez d'abord appliquer une certaine force physique vous-même pour fermer le lit. Ne vous inquiétez pas, vous ne le casserez pas !!!!!

18

T x 1



U x 1

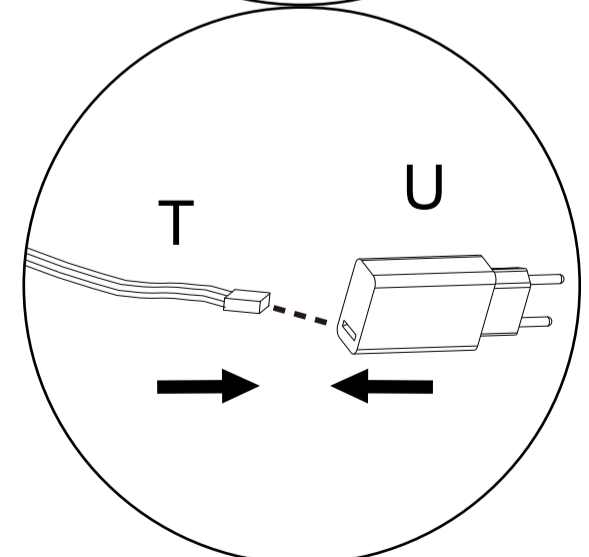
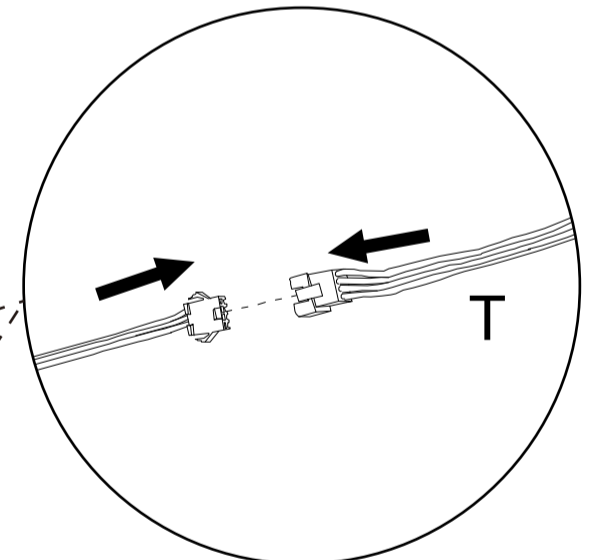
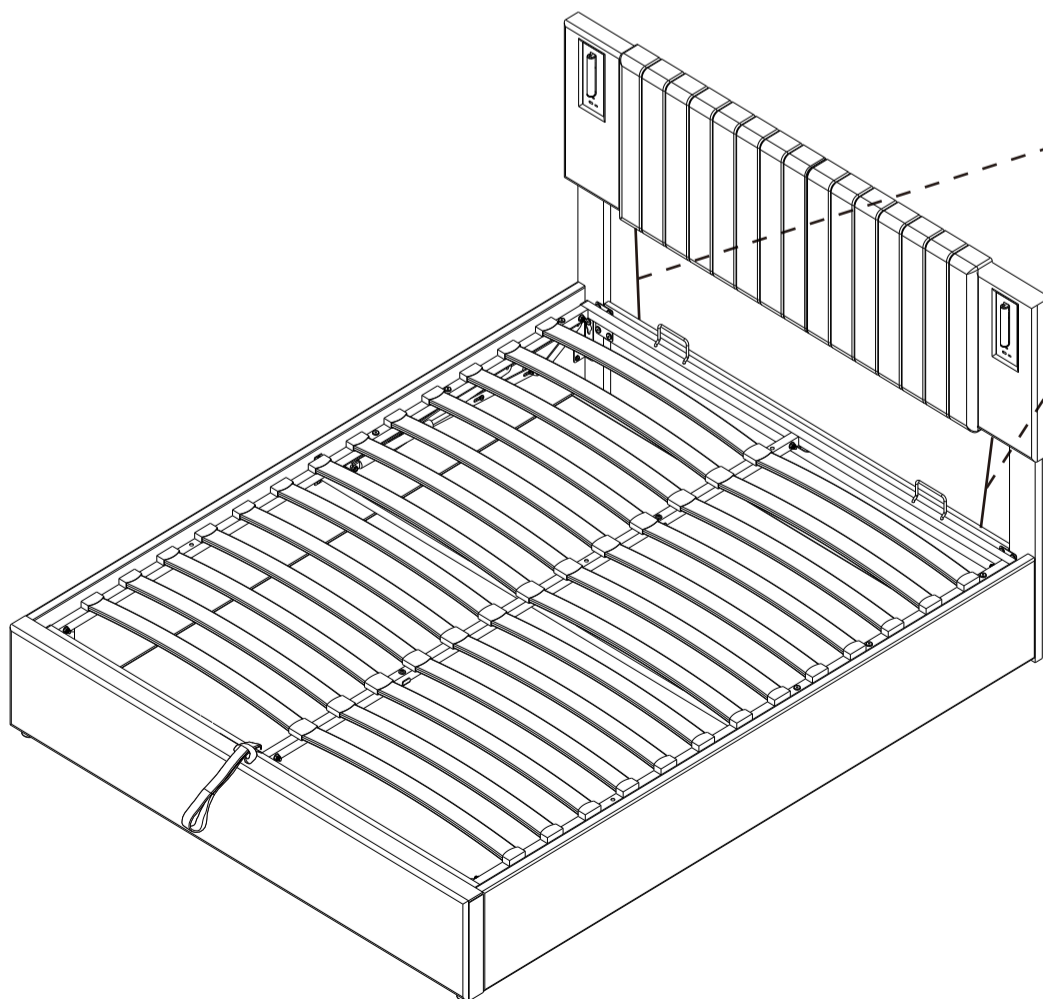

★ IMPORTANT NOTICE ★

HYDRAULIC BED OPERATING INSTRUCTIONS

Once your bed frame is completely assembled, the slat unit will not operate correctly unless a mattress is placed on the slat frame. Position the mattress on the slat frame whilst it is in the closed position.

PLEASE NOTE - It takes a lot of force to make the initial movement of the ottoman. This is a design feature of the product so that it does not fall shut the nearer to being closed the ottoman is, the easier it is to move. When the ottoman is almost shut, it will close completely under its own weight.

When lowering the slat unit for the first time, take care to make sure it does not rub unevenly on the inside face of the side rails. If it does, the bed has been assembled slightly out of square. This can be rectified by moving the foot end of the bed slightly to the left or right whilst leaving the head end stationary.

PISTONS

The pistons used in the construction of this product are extremely strong and cannot be operated by hand when taken off the ottoman. All pistons are tested for correct pressure and operation before being attached to the slat unit.

Initially it might appear that the pistons are very stiff when opening and closing the ottoman.

THIS IS PERFECTLY NORMAL

When fully assembled and the mattress is in position, please raise and lower the ottoman 4/5 times to ensure the gas piston are fully lubricated.

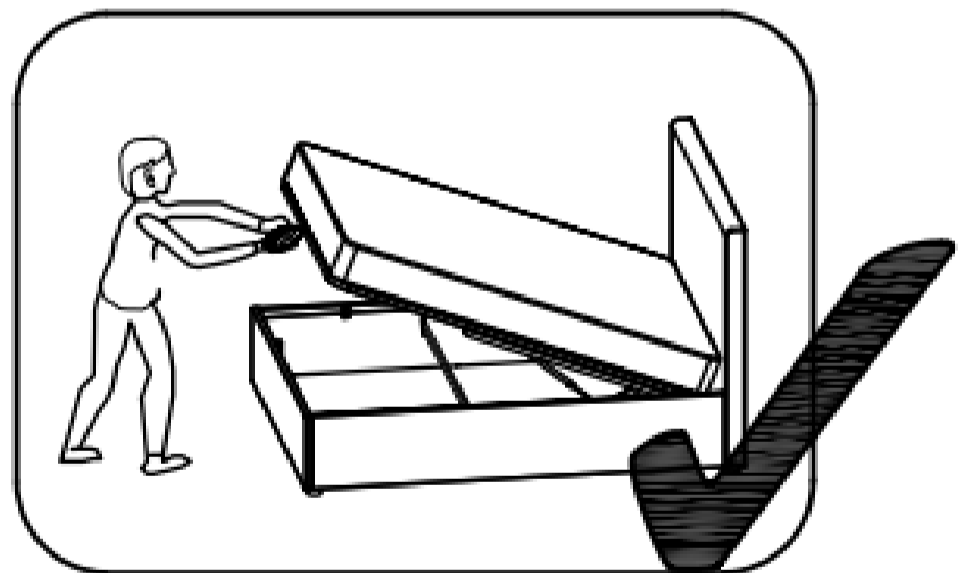
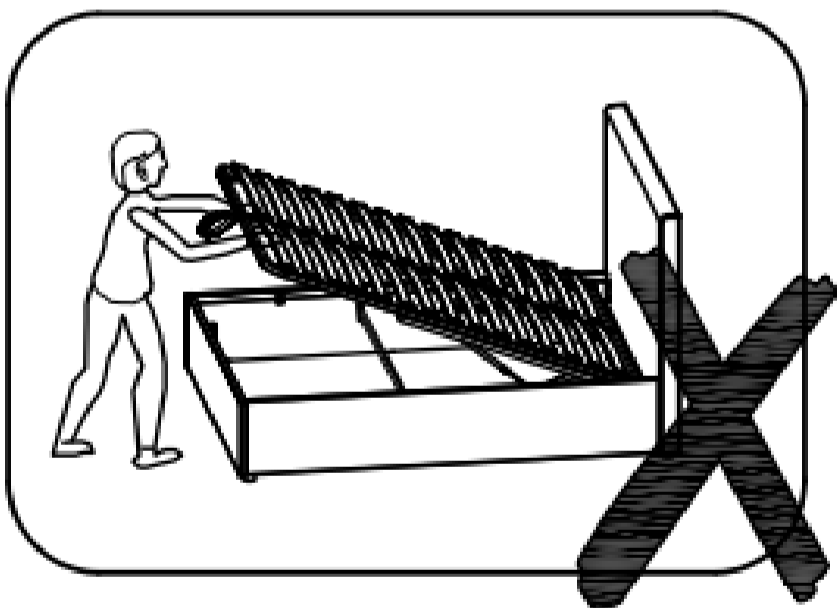



Certificate of Conformity

Certificate No. : WTY22030301001S

Report No. : WTY22030301001S

Applicant : Shenzhen Fangxin Technology Co. Ltd.
Address : The third floor,Bldg9, A6 Areal, Tongfuyu Industrial Park,
Shajing Street, Bao'an District, ShenZhen City, China
Product : USB Power ADAPTER
Brand Name : Fxin
Model No. : FX18E-050300U1, FX18E-050300U3, FX18E-050300U9,
FX18E-050300U12
Ratings : Input: 100-240V~, 50/60Hz, 0.5A, Class II apparatus
Output: See report for details.
Test Standard(s) : EN 62368-1:2014+A11:2017

This certificate of conformity is based on an evaluation of a sample of the above mentioned product. Technical Report and documentation are at the Licence Applicants disposal. Once compliance with all product relevant mark regulations are verified, including any relevant e.g. risk assessment and production control, the manufacturer may indicate compliance by signing a Declaration of Conformity themselves and applying the mark to products identical to the tested sample(s).



Hero wu
(Manager)
Mar. 23, 22

Shenzhen Watt Power Testing Institute Co., Ltd.

Tel: (86)-755-85297065

Fax: (86)-755-21500685

Http://: www.wtypower.com

Mail: test@wtypower.com

Area A, Floor 1, Building C, Guosheng Industrial Park, No. 101 Junxin Road, Shimajing community ,
Guanlan Street, Longhua New District, Shenzhen



Certificate of Conformity

Certificate No. : WTY22030301001E

Report No. : WTY22030301001E

Applicant : Shenzhen Fangxin Technology Co., Ltd
Address : The third floor,Bldg9, A6 Areal, Tongfuyu Industrial Park, Shajing Street, Bao'an District, ShenZhen City, China
Product : SWITCHING ADAPTER
Model No. : FX18E-050300U1, FX18E-050300U3, FX18E-050300U9, FX18E-050300U12
Ratings :

Model No.	Rating input	Rating output	Output Power (W. Max)
FX18E-050300U1	100-240V~, 50/60Hz, 0.5A	5VDC, 3A; 9VDC, 2A;12VDC, 1.5A.	18.0
FX18E-050300U3		5VDC, 3A	15.0
FX18E-050300U9		9VDC, 2A	18.0
FX18E-050300U12		12VDC, 1.5A	18.0

Test Standard(s) : EN 55032:2015/A11:2020
EN 55035:2017/A11:2020
EN IEC61000-3-2:2019/A1:2021
EN 61000-3-3:2013/A1:2019

This certificate of conformity is based on an evaluation of a sample of the above mentioned product. Technical Report and documentation are at the License Applicant's disposal. This is to certify that the tested sample is in conformity with the Directive 2014/30/EU relating to electromagnetic compatibility.

This certificate does not imply assessment of the series-production of the product. The Applicant of the certificate is authorized to use this certificate in connection with the EC declaration of conformity according to Annex IV of the Directive.



Hero wu
(Manager)
Mar. 18, 2022

Shenzhen Watt Power Testing Institute Co., Ltd.

Tel: (86)-755-85297065

Fax: (86)-755-21500685

Http://: www.wtypower.com

Mail: test@wtypower.com

Floor 1, Bldg. C, Guosheng Industry Zone, No. 101 Junxin Road, Guanlan, Longhua New District, Shenzhen