

ASSEMBLY INSRTRUCTION BAUANLEITUNG

WF316770

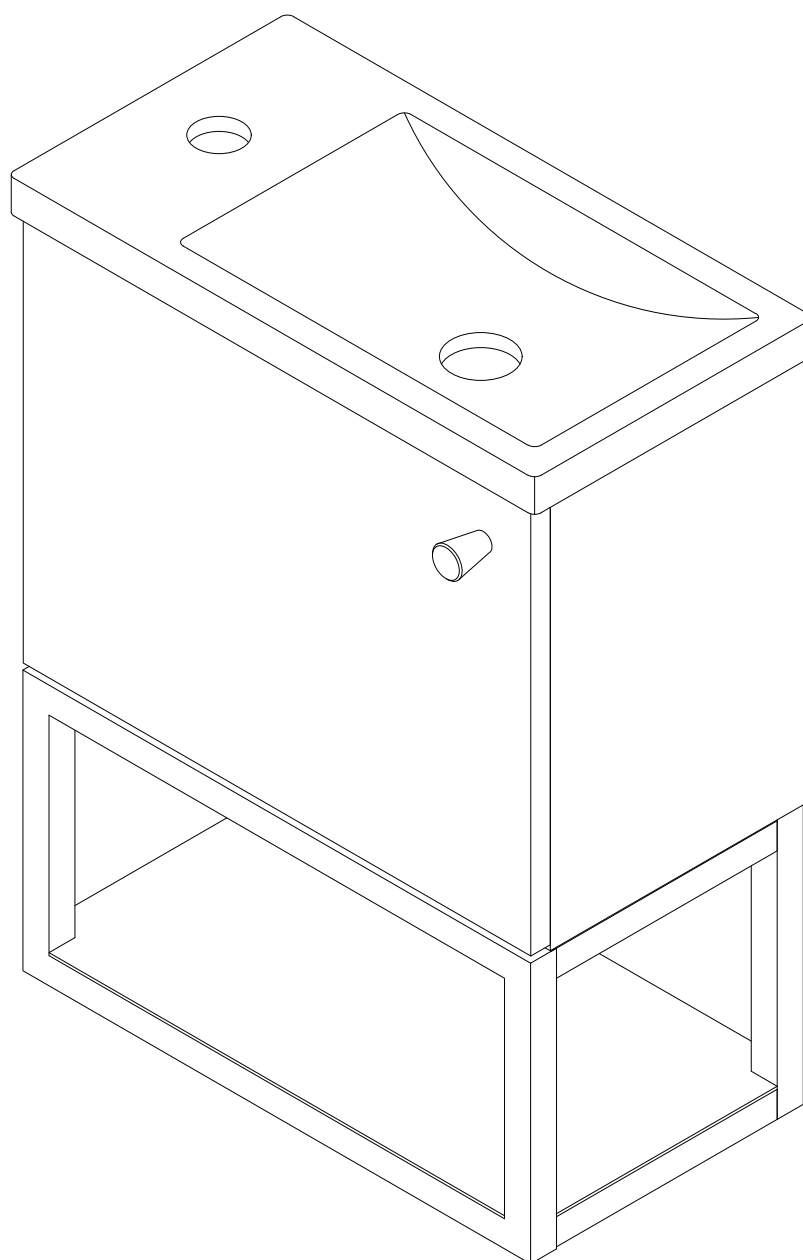

Before Installation

Important-Please read these instructions fully before starting assembly

Thank you for purchasing this quality product. Be sure to check all packing materials carefully for small parts, which may have come loose inside the carton during shipment. Identify and count all items according to the PARTS LIST and/or HARDWARE LIST shown below. Check you have all the components and tools listed on the following pages.

- We recommend that you assemble this product with the assistance of another person; this will make the assembly easier, and will help eliminate damage to the product or injury to persons during assembly.
- Please do not over tighten screws or bolts until the assembly is completed.
- Keep children and animal away from the work area, small parts could choke if swallowed. Please put all parts on a non-abrasive floor before assembly, and follow the assembly steps to assemble your newly purchased product correctly and efficiently.

Cam Lock Assembly Instructions

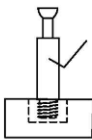
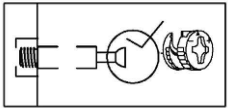
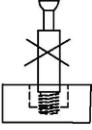
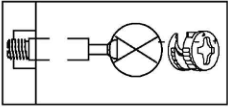
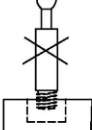
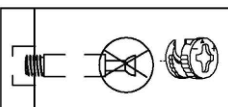
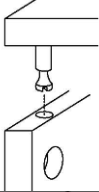
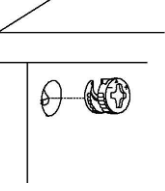
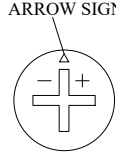
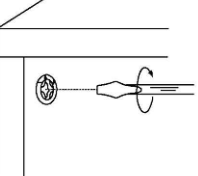
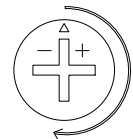
		Diagram A Insert Cam Bolt into hole as shown in diagram A.
		Diagram B Make sure not to insert the Cam Bolt: Too deep as shown in figure B as this will cause the Cam Lock to be misaligned and unable to interlock properly.
		Diagram C Also avoid inserting the Cam Bolt too close to the surface of the hole as shown in figure C, as this will cause the Cam Lock to be too loose, and not interlock properly.
		Connect the panels together.
		ARROW SIGN Insert the Cam Lock so the side opening fits over the head of the Cam Bolt.
		To tighten the Cam Lock, turn it clockwise on half a turn with a flat screwdriver. *Do not use an automatic screwdriver as it may bend or break if too much power is imposed.

Vor der Montage

Wichtig: Bitte lesen Sie diese Anleitung vollständig durch, bevor Sie mit der Montage beginnen.

Wir danken Ihnen für den Kauf dieses Qualitätsprodukts. Überprüfen Sie alle Verpackungsmaterialien sorgfältig auf Kleinteile, die sich während des Transports aus dem Karton gelöst haben könnten, und zählen Sie alle Teile gemäß der unten aufgeführten TEILELISTE und/oder EISENWARENLISTE.

- Wir empfehlen Ihnen, dieses Produkt mit Hilfe einer anderen Person zu montieren; dies erleichtert die Montage und hilft, Schäden am Produkt oder Verletzungen von Personen während der Montage zu vermeiden.
- Bitte ziehen Sie die Schrauben und Bolzen nicht zu fest an, bevor die Montage abgeschlossen ist.
- Bitte legen Sie alle Teile vor der Montage auf einen nicht scheuernden Boden und befolgen Sie die Montageschritte, um Ihr neu erworbenes Produkt korrekt und effizient zu montieren.

Anweisungen zur Montage des Nockenschlosses

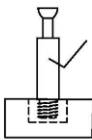
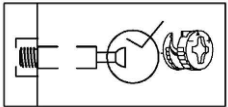
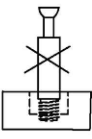
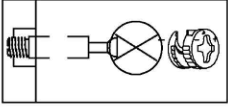
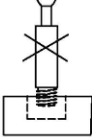
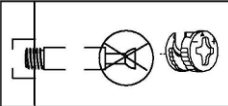
	<p>Diagram A</p> <p>Führen Sie den Nockenbolzen in das Loch ein, wie in Abbildung A dargestellt.</p>
	<p>Diagram B</p> <p>Stellen Sie sicher, dass Sie den Nockenbolzen nicht zu tief einführen: Zu tief, wie in Abbildung B gezeigt, da dies dazu führt, dass die Nockensperre falsch ausgerichtet ist und nicht richtig einrasten kann.</p>
	<p>Diagram C</p> <p>Vermeiden Sie auch, den Nockenbolzen zu nahe an der Oberfläche des Lochs einzusetzen, wie in Abbildung C gezeigt, da dies dazu führt, dass die Nockensperre zu locker ist und nicht richtig einrastet.</p>
	<p>Verbinden Sie die Platten miteinander.</p>
	<p>ARROW SIGN</p> <p>Setzen Sie die Nockensperre so ein, dass die seitliche Öffnung über den Kopf des Nockenbolzens passt.</p>
	<p>Drehen Sie die Nockensperre mit einem flachen Schraubenzieher eine halbe Umdrehung im Uhrzeigersinn, um sie festzuziehen. *Verwenden Sie keinen automatischen Schraubendreher, da er sich verbiegen oder brechen kann, wenn zu viel Kraft aufgewendet wird.</p>

Avant l'installation

Important - Veuillez lire attentivement ces instructions avant de commencer l'assemblage.

Nous vous remercions d'avoir acheté ce produit de qualité. Merci d'avoir acheté ce produit de qualité. Veuillez à vérifier soigneusement tous les matériaux d'emballage à la recherche de petites pièces qui auraient pu se détacher à l'intérieur du carton pendant le transport. Identifiez et comptez tous les articles selon la LISTE DE PIÈCES et/ou la LISTE DE MATÉRIEL figurant ci-dessous. Vérifiez que vous disposez de tous les composants et outils énumérés dans les pages suivantes.

- Nous vous recommandons d'assembler ce produit avec l'aide d'une autre personne ; cela facilitera l'assemblage et permettra d'éviter d'endommager le produit ou de blesser des personnes pendant l'assemblage.
- Ne serrez pas trop les vis ou les boulons jusqu'à ce que l'assemblage soit terminé.
- Veuillez placer toutes les pièces sur un sol non abrasif avant l'assemblage, et suivez les étapes d'assemblage pour assembler correctement et efficacement le produit que vous venez d'acheter.

Instructions d'assemblage de la serrure à came

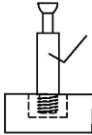
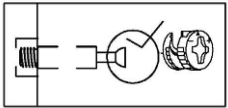
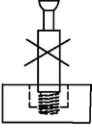
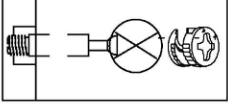
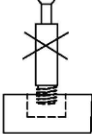
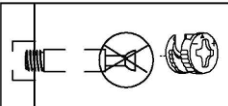
	<p>Diagram A</p> <p>Insérer le boulon à came dans le trou comme indiqué dans le diagramme A.</p>
	<p>Diagram B</p> <p>Veillez à ne pas insérer le boulon à came : trop profond, comme indiqué dans la figure B, car cela entraînerait un désalignement du verrou à came et l'impossibilité de s'emboîter correctement.</p>
	<p>Diagram C</p> <p>Évitez également d'insérer le boulon à came trop près de la surface du trou, comme le montre la figure C, car le verrou à came serait trop lâche et ne s'emboîterait pas correctement.</p>
	<p>Reliez les panneaux entre eux.</p>
	<p>ARROW SIGN</p> <p>Insérez le Cam Lock de manière à ce que l'ouverture latérale s'insère sur la tête du Cam Bolt.</p>
	<p>Pour serrer le Cam Lock, tournez-le d'un demi-tour dans le sens des aiguilles d'une montre à l'aide d'un tournevis plat. *N'utilisez pas de tournevis automatique, car il pourrait se déformer ou se casser s'il est trop puissant.</p>

HINGE ADJUSTMENT GUIDE

EN_It may be necessary to adjust the hinges so that the doors align. Use the instructions below as a guide. FR_Il est parfois necessaire d'ajuster les charnieres pour un meilleur alignement des portes. Servez-vous des instructions ci-dessous comme guide. DE_moglicherweise müssen Sie die Scharniere so einstellen, dass die Türen ausgerichtet sind. Verwenden Sie die nachstehenden Anweisungen als Leitfaden.

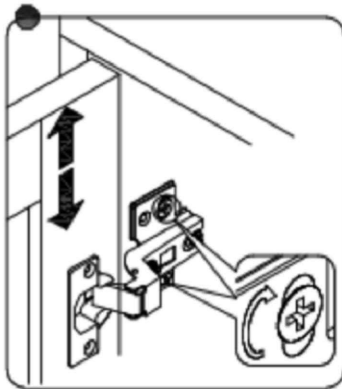

EN_To adjust the door vertically loosen the screw as shown and move up and down as needed.

FR_Si vous souhaitez regler la porte verticalement, desserrez la vis comme indique et deplacez la porte de haut en bas selon les besoins.

DE_Um die Tür vertikal auszurichten, lösen Sie die Schraube wie abgebildet und bewegen Sie sie nach Bedarf nach oben oder nach unten.



EN_To adjust the gap from the door to the main frame turn the screw clockwise or anti-clockwise as needed.

FR_Si vous souhaitez ajuster l'ecart entre la porte et le cadre principal, tournez la vis dans le sens des aiguilles d'une montre ou dans le sens inverse, si necessaire.

DE_Um den Abstand von der Tür zum Hauptrahmen auszurichten, drehen Sie die Schraube wie nach Bedarf im oder gegen den Uhrzeigersinn.

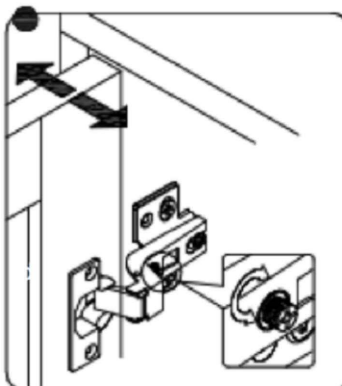

EN_To adjust the door laterally adjust the screw as shown by turning clockwise or anti-clockwise.

FR_Si vous souhaitez ajuster la porte lateralement, ajustez la vis comme indique en tournant dans le sens des aiguilles d'une montre ou dans le sens inverse des aiguilles d'une montre.

DE_Um die Tür seitlich auszurichten, stellen Sie bitte die Schraube wie abgebildet durch Drehen im oder gegen den Uhrzeigersinn ein.

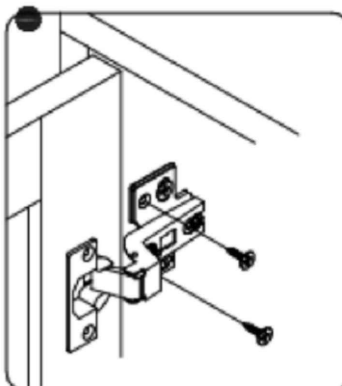







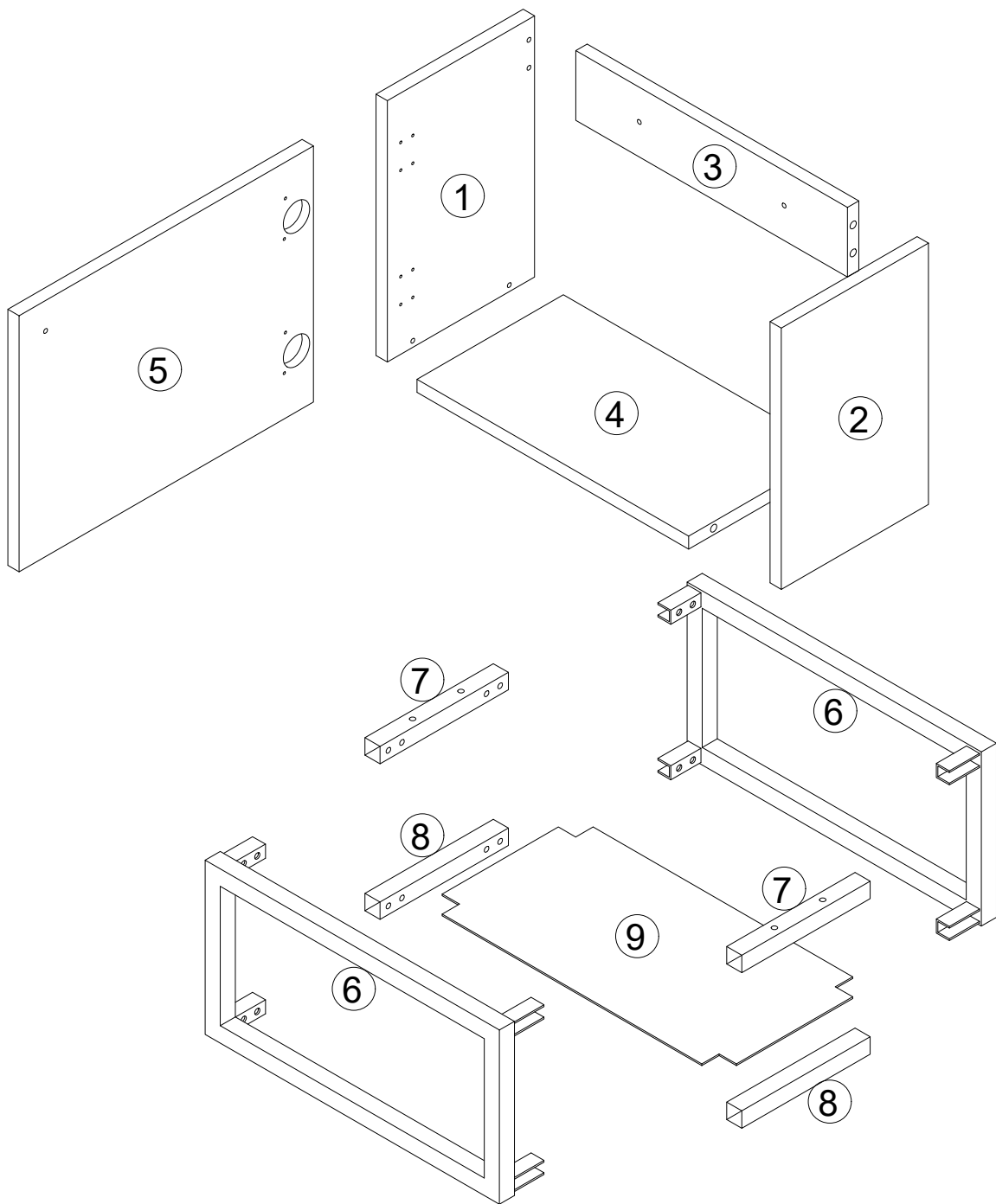

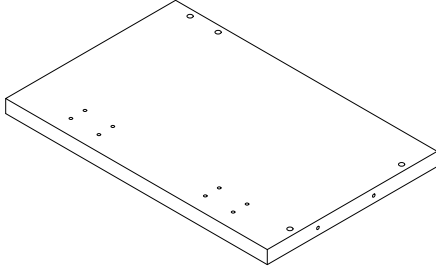
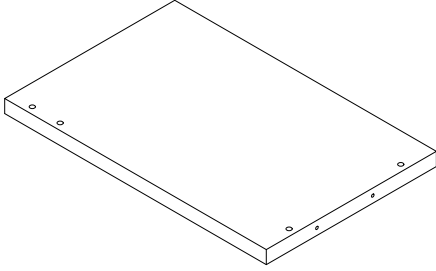
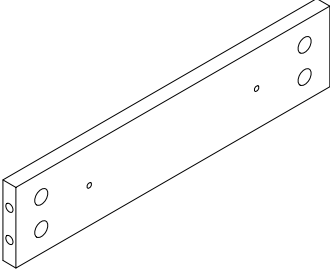
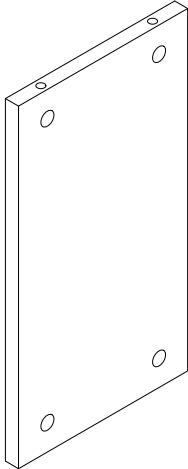
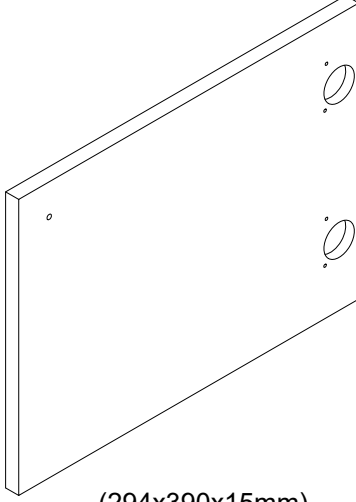
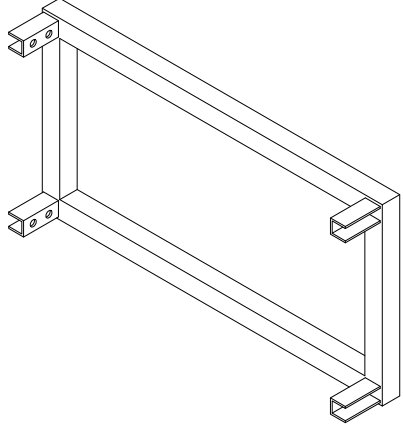
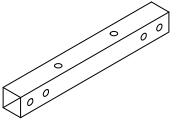
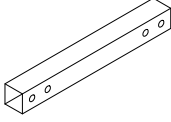
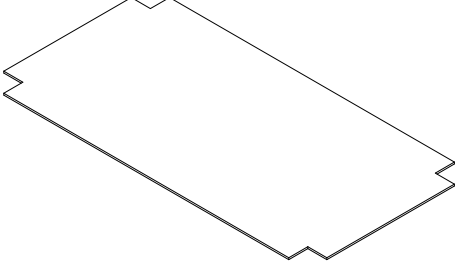

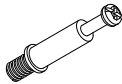
EN_Please fix other screws.

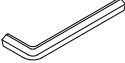
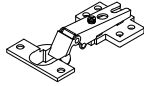
FR_Merci de serrer les autres vis.

DE_Befestigen Sie bitte die anderen Schrauben.



		
(300x195x15mm)	(300x195x15mm)	(360x80x15mm)
① x 1	② x 1	③ x 1
		
(300x194x15mm)	(294x390x15mm)	(390x200x20mm)
④ x 1	⑤ x 1	⑥ x 2
		
(170x20x20mm)	(170x20x20mm)	(390x200x2mm)
⑦ x 2	⑧ x 2	⑨ x 1

					
Φ6x35mm A x 8+1	Φ15x12mm B x 8+1	M6x12mm C x 8+1	M4 D x 1	E x 2	M4x14mm F x 12+1
					
M4x20mm G x 1	H x 1	M4x35mm I x 4	Φ6x30mm J x 2	Φ16mm K x 2	M5x45mm L x 2

Step 1

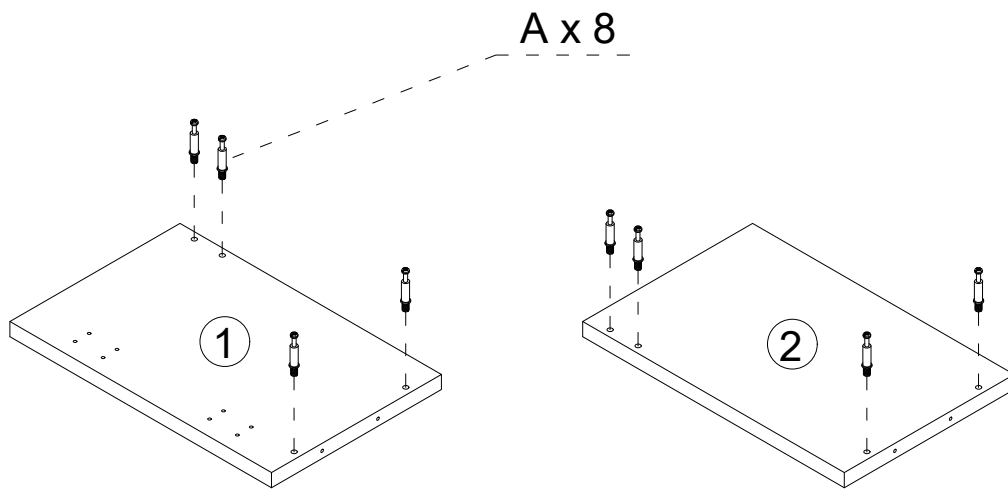

Step 2

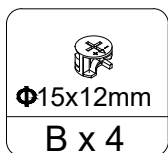
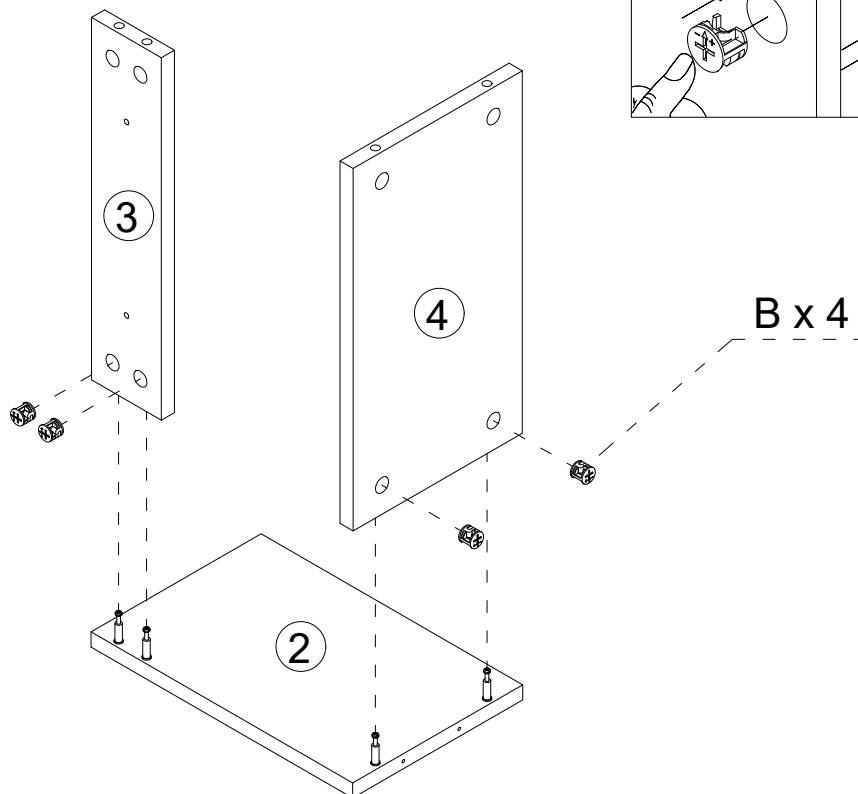

Step 3

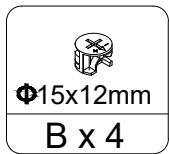
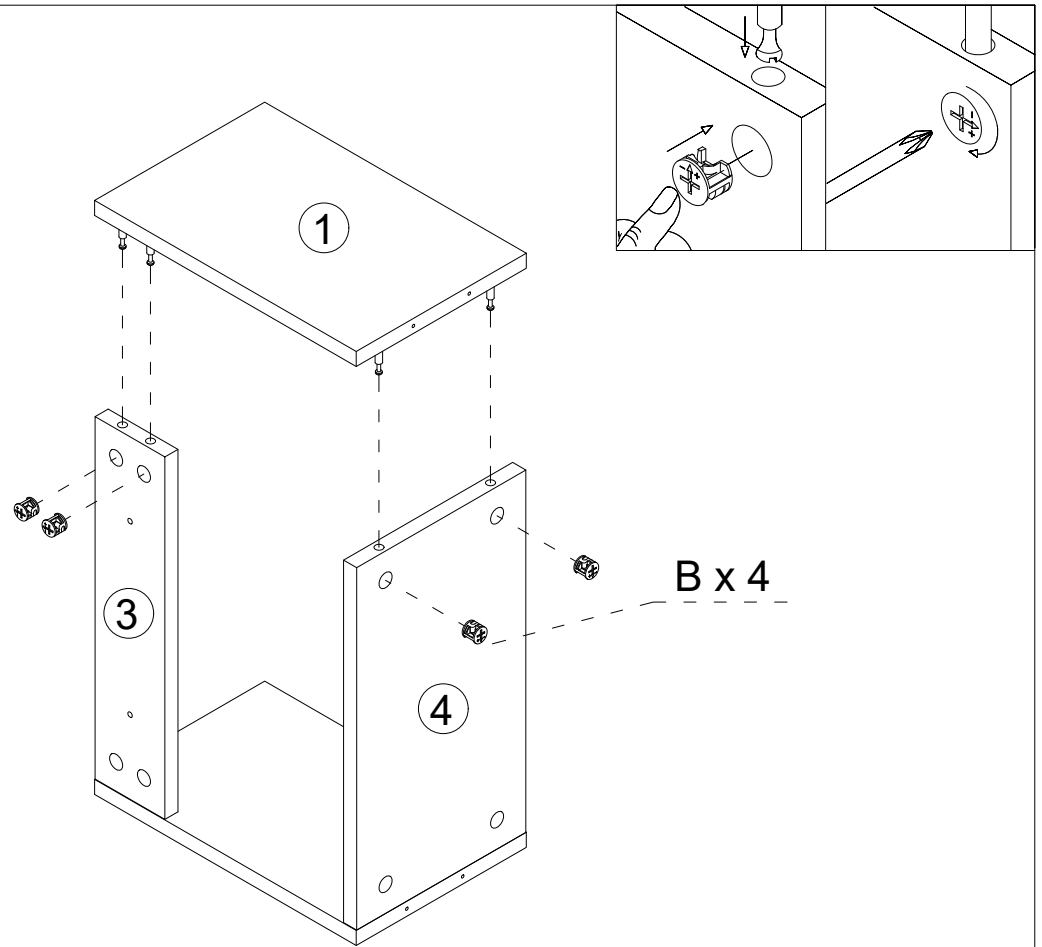

Step 4

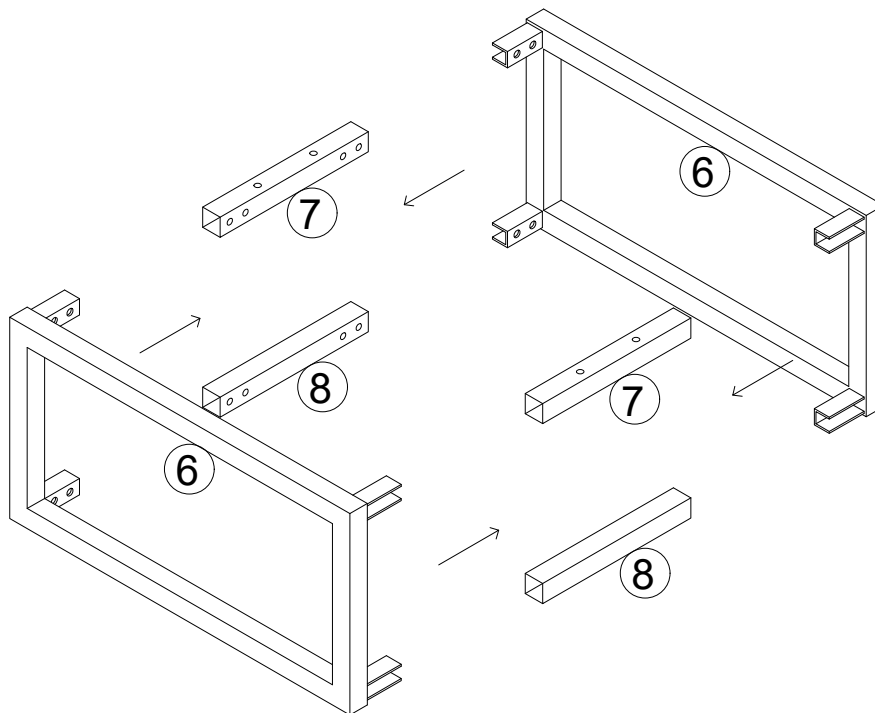

Step 5

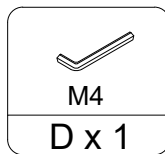
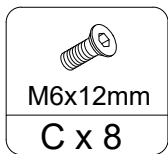
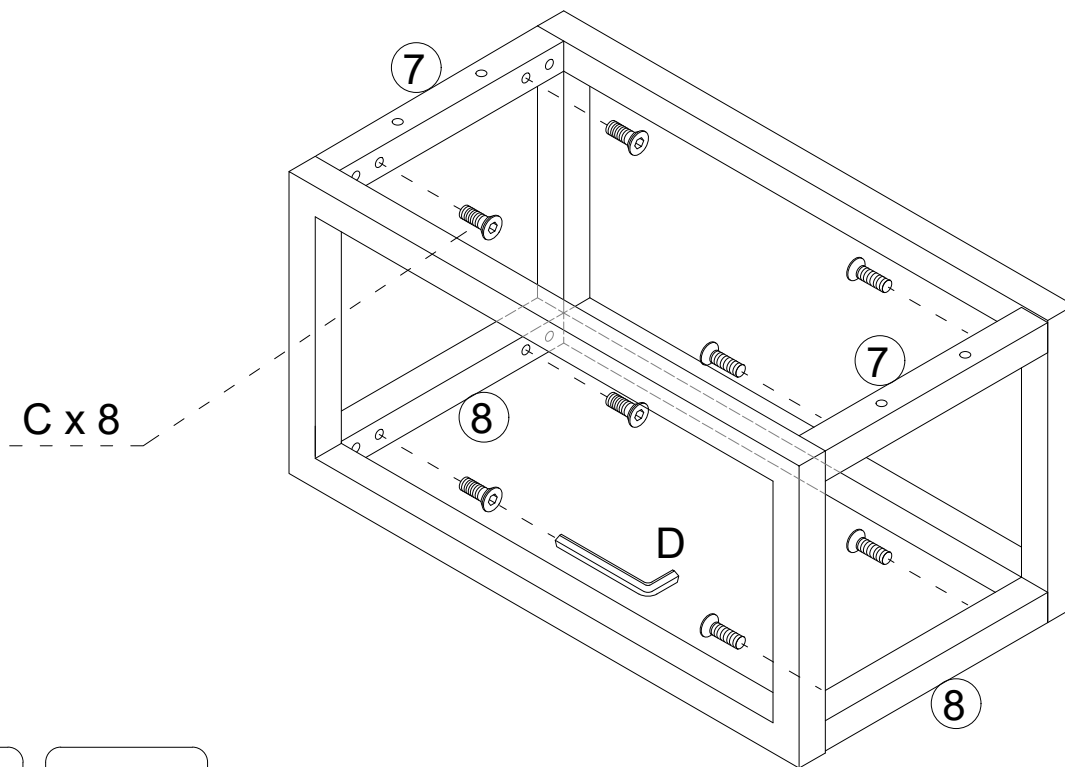

Step 6

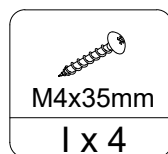
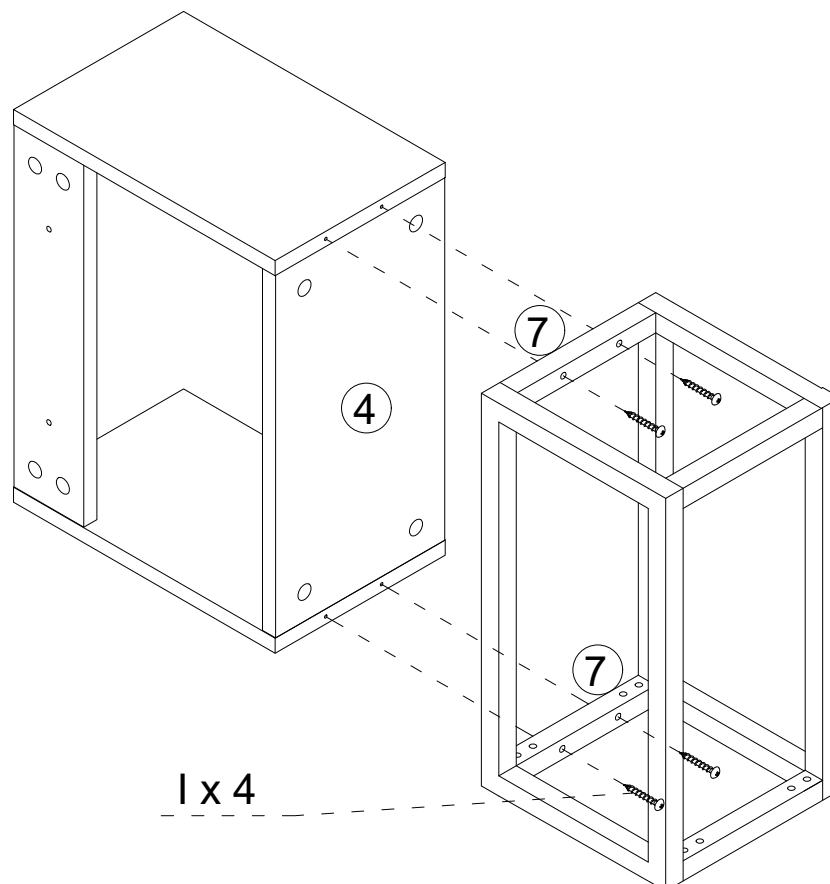

Step 7

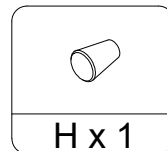
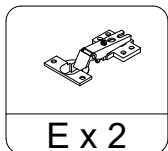
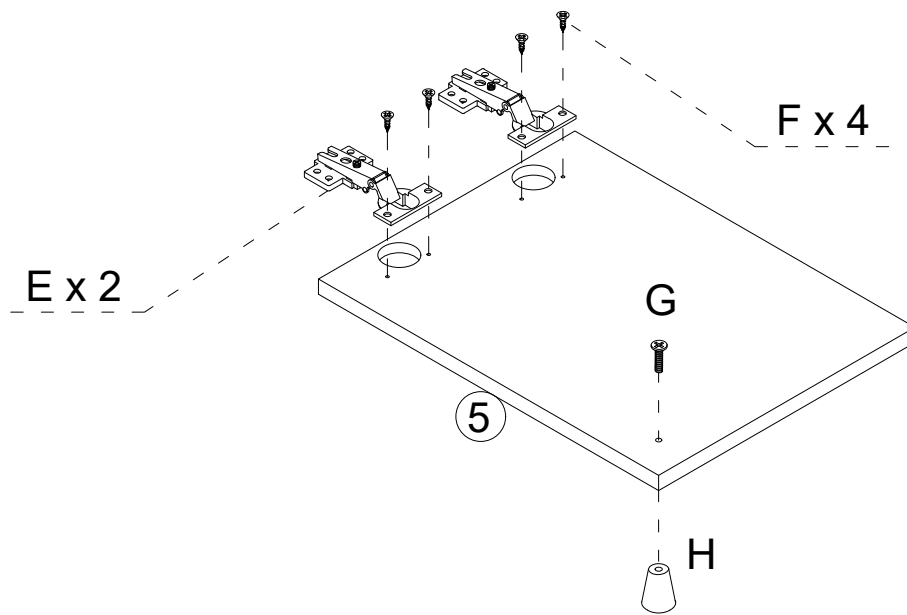

Step 8

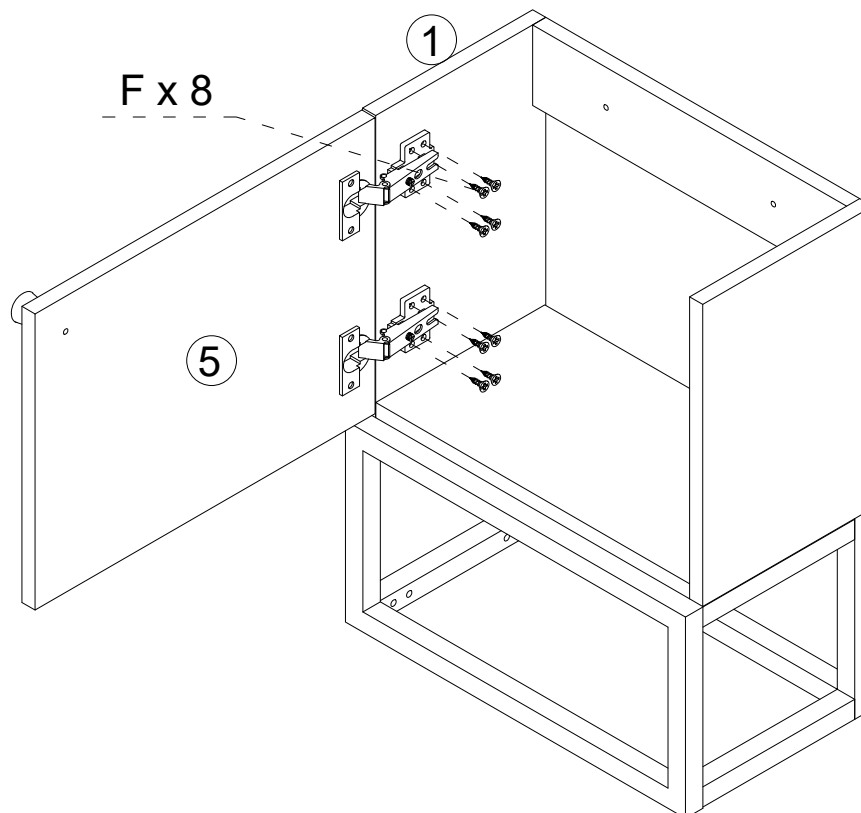

Step 9

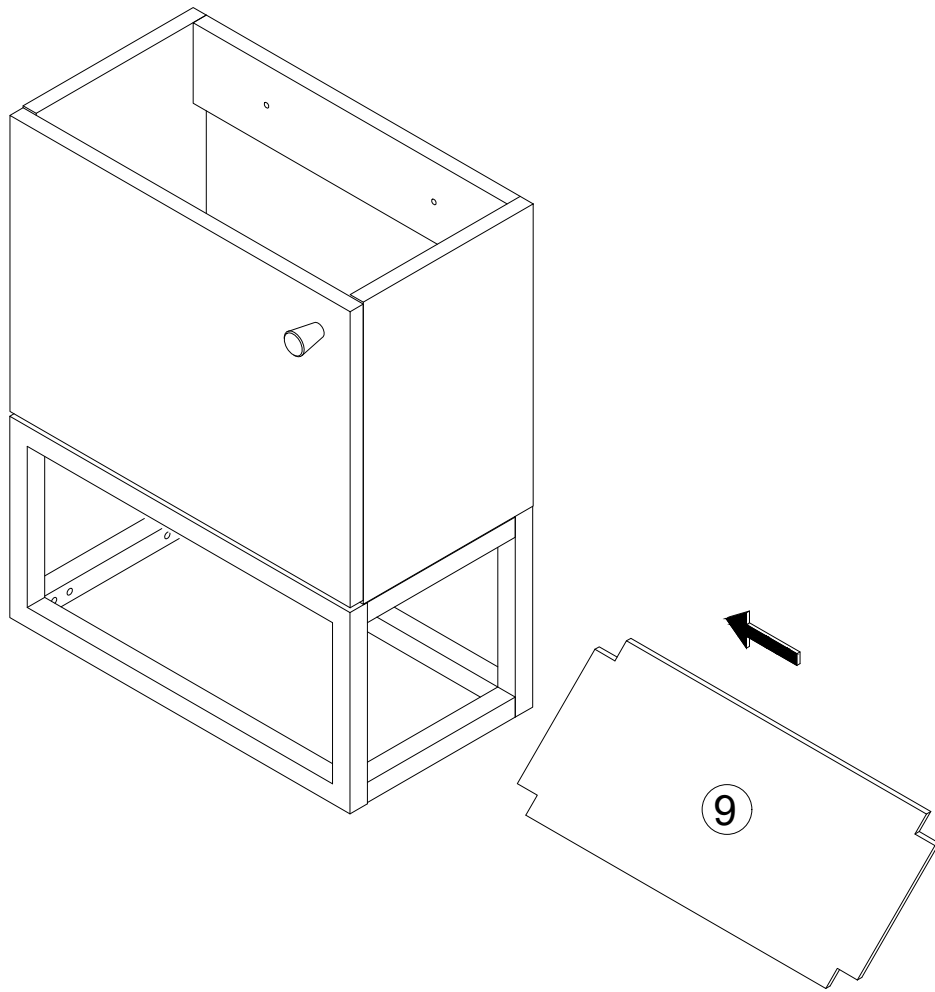

Step 10

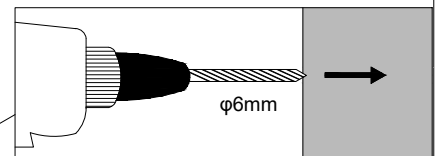
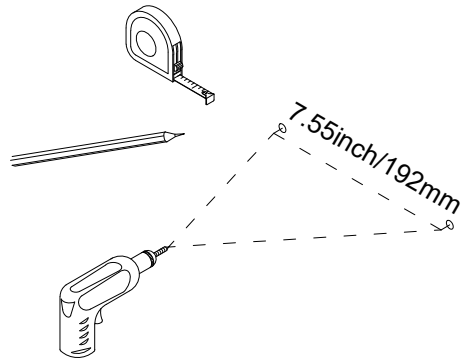
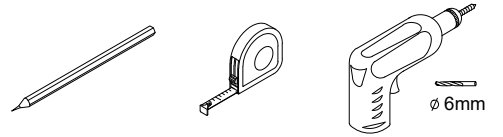

Step 11

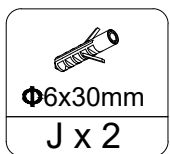
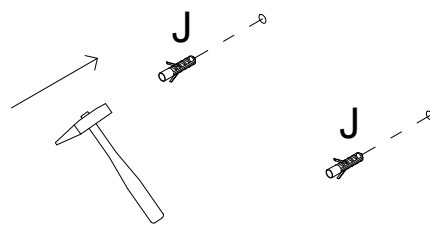
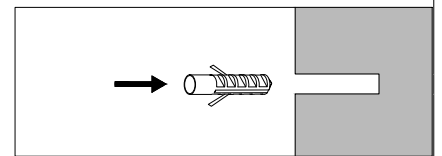

Step 12

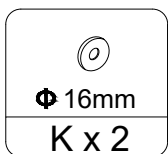
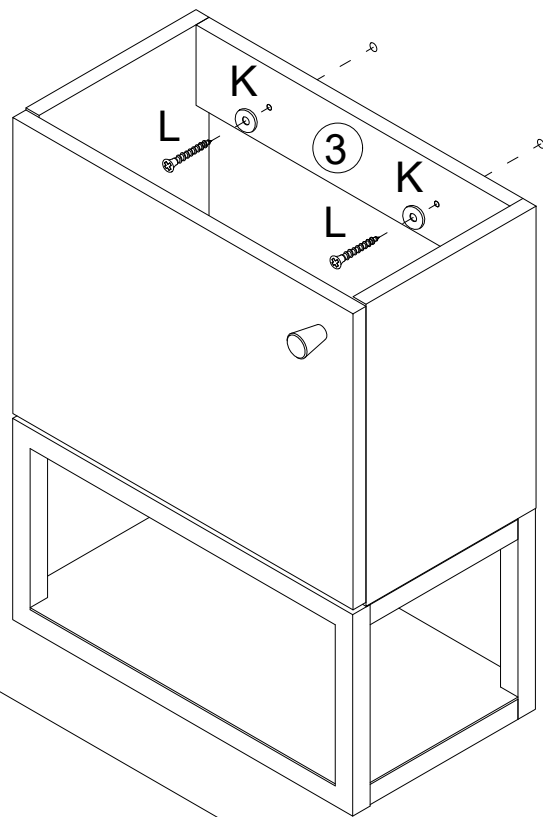

Step 13

