

# MONTAGEANLEITUNG

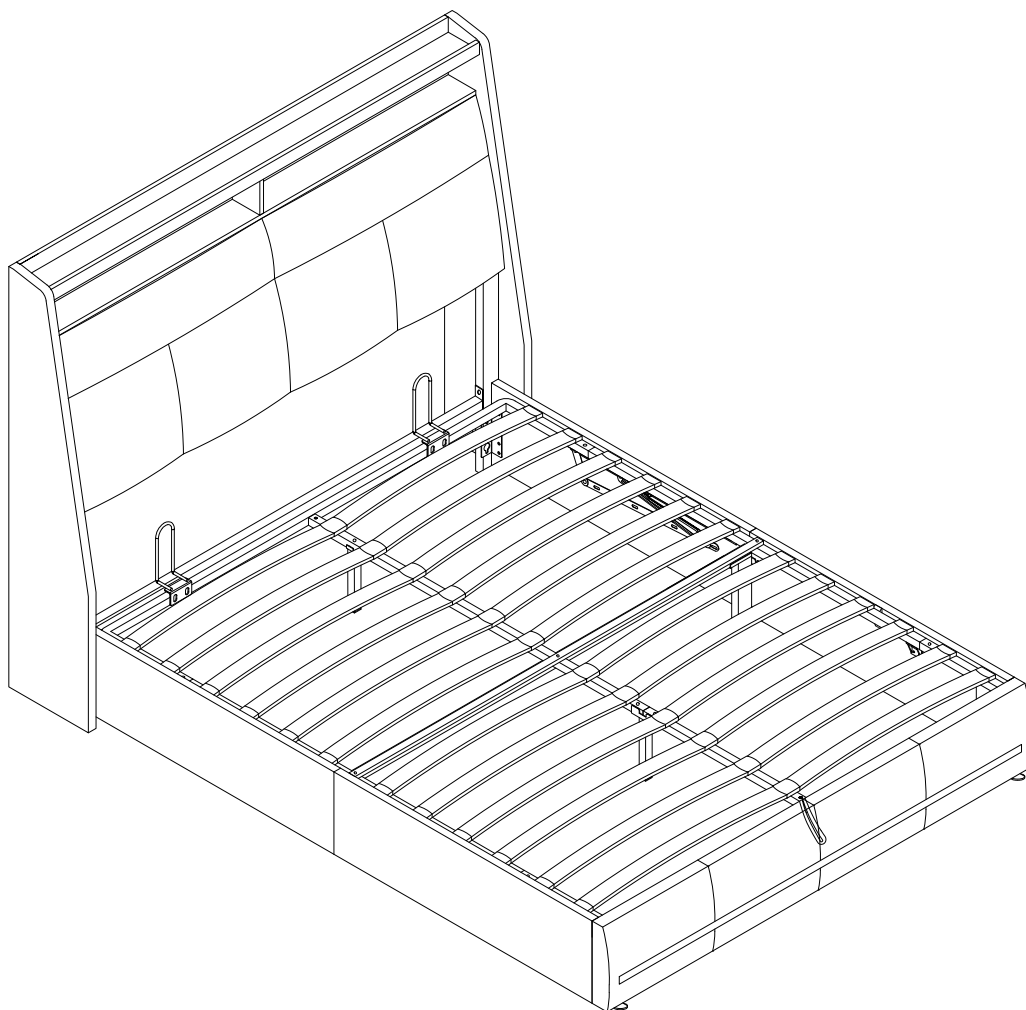

Please check that all parts are included before starting assembly. If you specify that something is missing, do not continue the assembly. Please contact us immediately.

Bitte überprüfen Sie, ob alle Teile mitgeliefert sind, bevor Sie mit der Montage beginnen. Wenn Sie festlegen, dass etwas fehlt, setzen Sie die Montage nicht fort. Bitte kontaktieren Sie uns sofort.

Vérifiez que toutes les pièces sont incluses avant de commencer l'assemblage. Si vous définissez Si quelque chose manque, ne continuez pas avec l'Assembly. Contactez - nous immédiatement.

Please read the complete instructions before installing this product. Please let at least two people participate in the assembly of this product!

Bitte lesen Sie die vollständige Anleitung, bevor Sie dieses Produkt montieren. Bitte lassen Sie mindestens zwei Personen an der Montage dieses Produkts teilnehmen !

Veillez lire les instructions complètes avant d'installer ce produit. Veuillez faire participer au moins deux personnes à l'assemblage de ce produit!

Attention: Please do not tighten all screws before assembly is complete!

Achtung: Bitte ziehen Sie nicht alle Schrauben fest, bevor die Montage abgeschlossen ist !

Remarque: s'il vous plaît ne pas serrer toutes les vis avant l'assemblage est terminé!

# MONTAGEANLEITUNG

## BOX 2/3

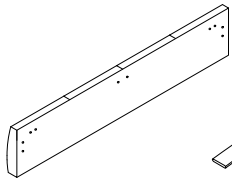

2. 1pc

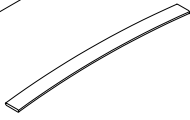

10. 24pcs

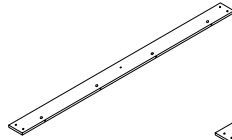

42. 1pc

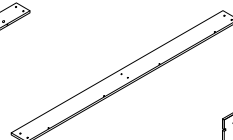

43. 1pc

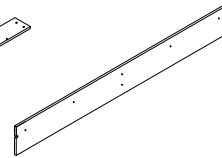

44. 1pc



45. 1pc

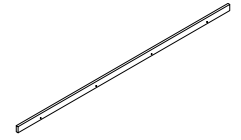

46. 1pcs

## BOX 3/3

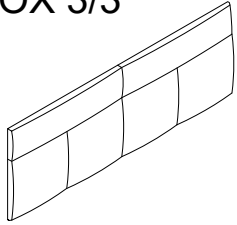

1. 1pc



13. 1pc



14. 1pc

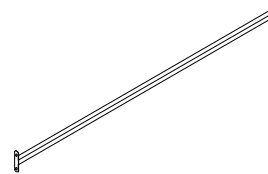

15. 1pc

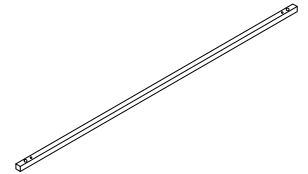

16. 1pc

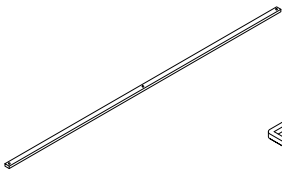

17. 1pc

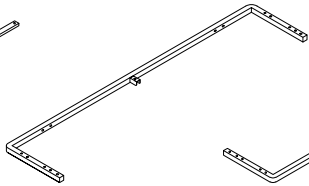

18. 1pc

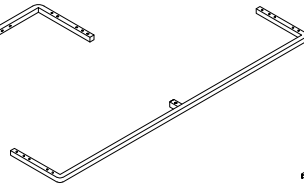

19. 1pc

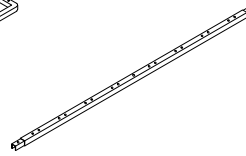

20. 2pcs

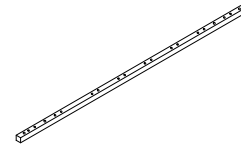

21. 1pc

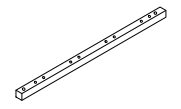

22. 1pc

## BOX 1/3



3. 1pc



4. 1pc

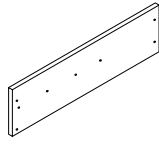

5. 1pc

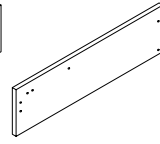

6. 1pc

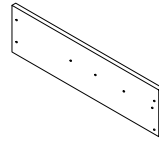

7. 1pc

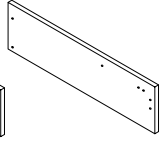

8. 1pc



9. 2pcs

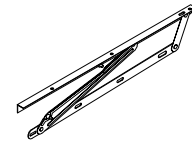

11. 1pc

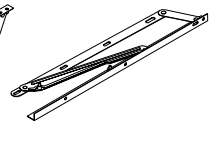

12. 1pc

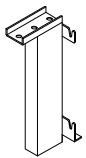

23. 2pcs

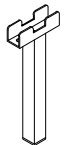

24. 1pc

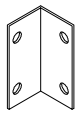

25. 6pcs

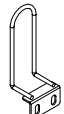

26. 2pcs



27. 1pc



28. 2pcs

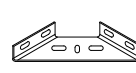

29. 2pcs



30. 1pc



31. 2pcs



32. 2pcs



33. 24pcs



34. 12pcs



35. 1pc

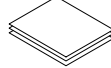

36. 1pc



37. 1pc

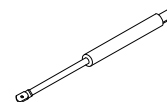

38. 2pcs



39. 1pc



40. 1pc



41. 1pc



M6\*10  
A. 8pcs



M8\*18  
B. 72pcs



M8\*25  
C. 7pcs



M8\*35  
D. 5pcs

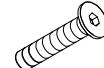

M8\*45  
E. 2pcs



M8\*65  
F. 4pcs



M4\*25  
G. 4pcs



H. 1pc

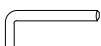

I. 1pc



J. 1pc



K. 4pcs



L. 1pc



M4\*38  
M. 13pcs



N. 5pcs



O. 5pcs

# MONTAGEANLEITUNG

Schritt:1

B x4pcs

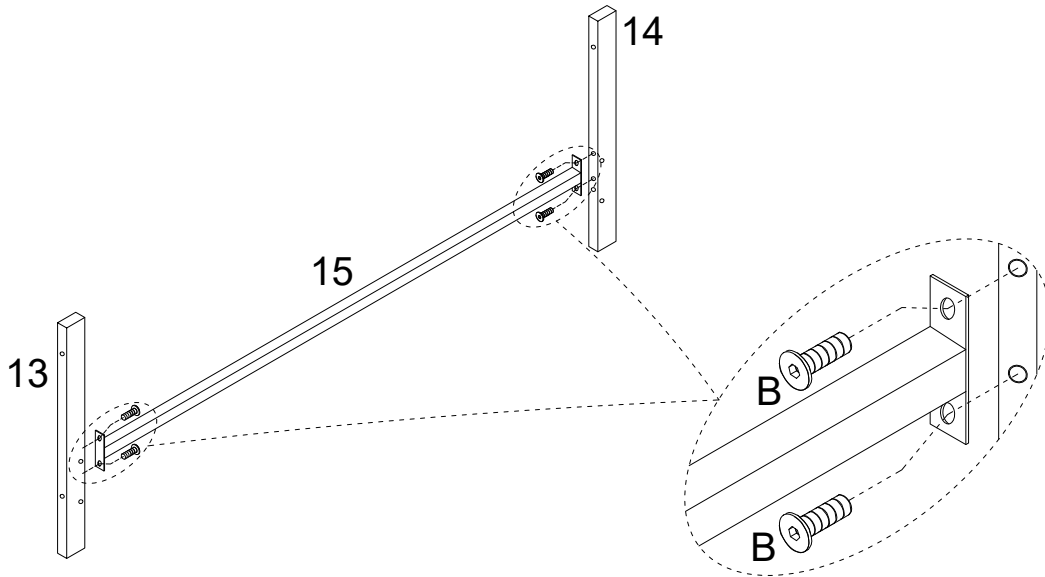

Schritt:2

B x10pcs

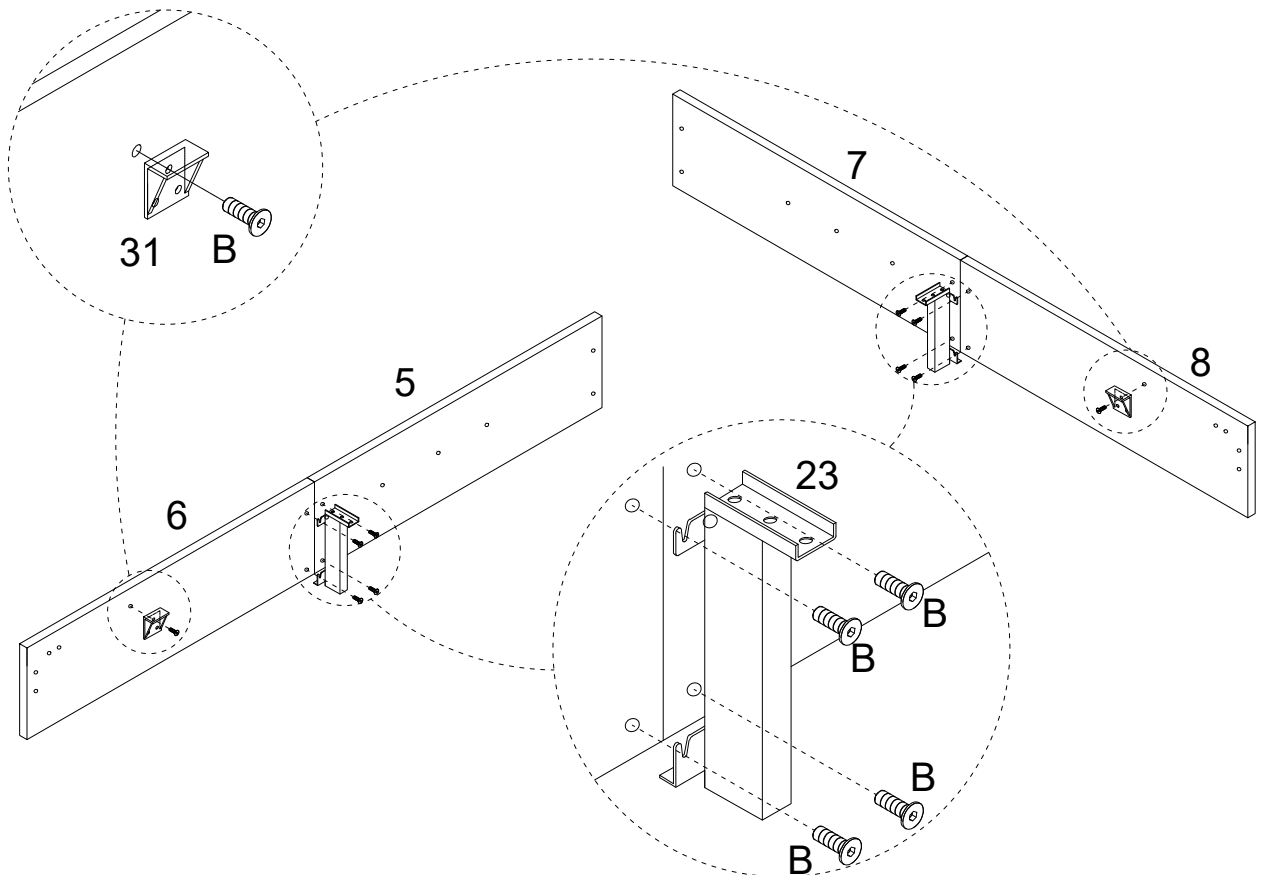

# MONTAGEANLEITUNG

## Schritt:3

Install component 32 in the middle position between components 6 and 8 and align it up  
Installieren Sie Komponente 32 in der mittleren Position zwischen Komponenten 6 und 8 und richten Sie sie oben aus  
Monter la pièce 32 dans une position intermédiaire entre les pièces 6 et 8 et l'aligner vers le H au

B x8pcs  
G x4pcs

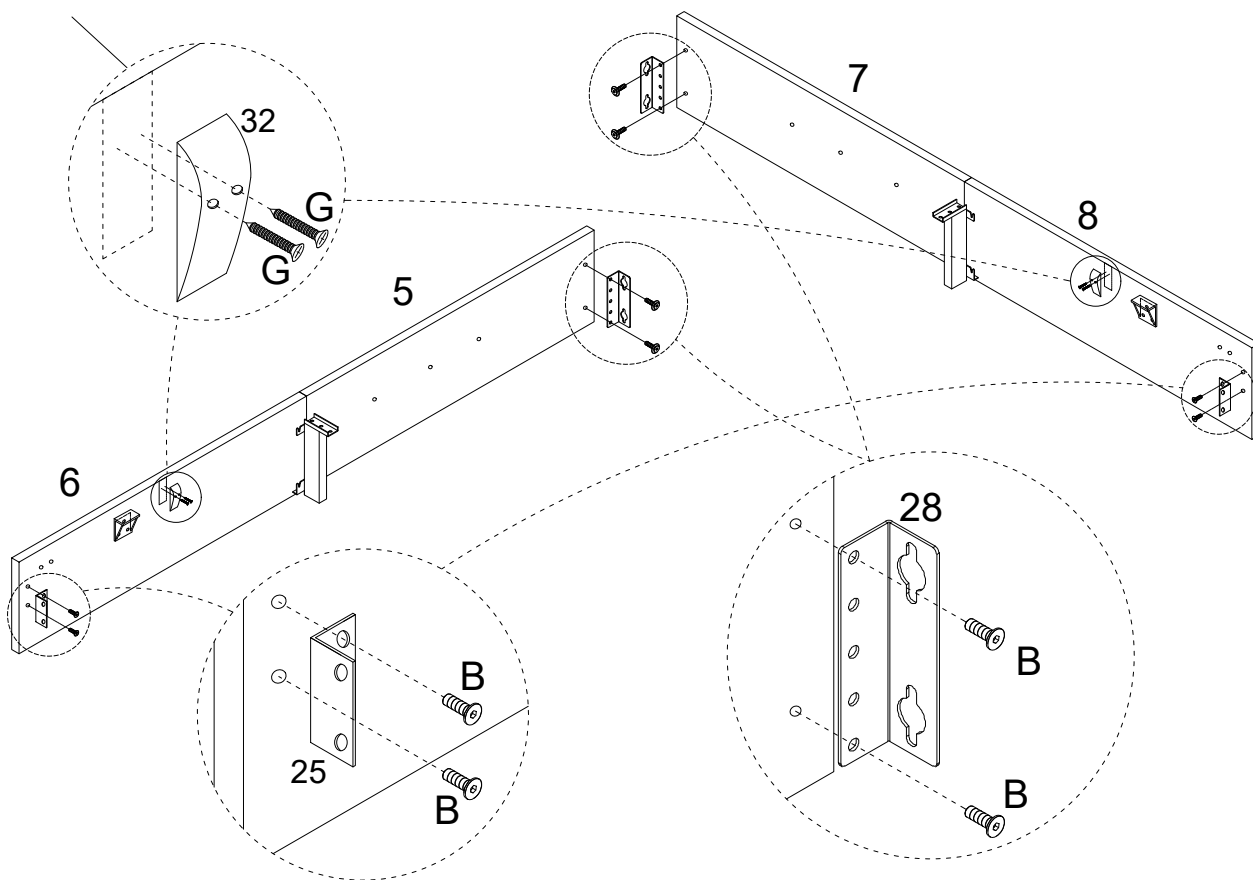

## Schritt:4

E x2pcs

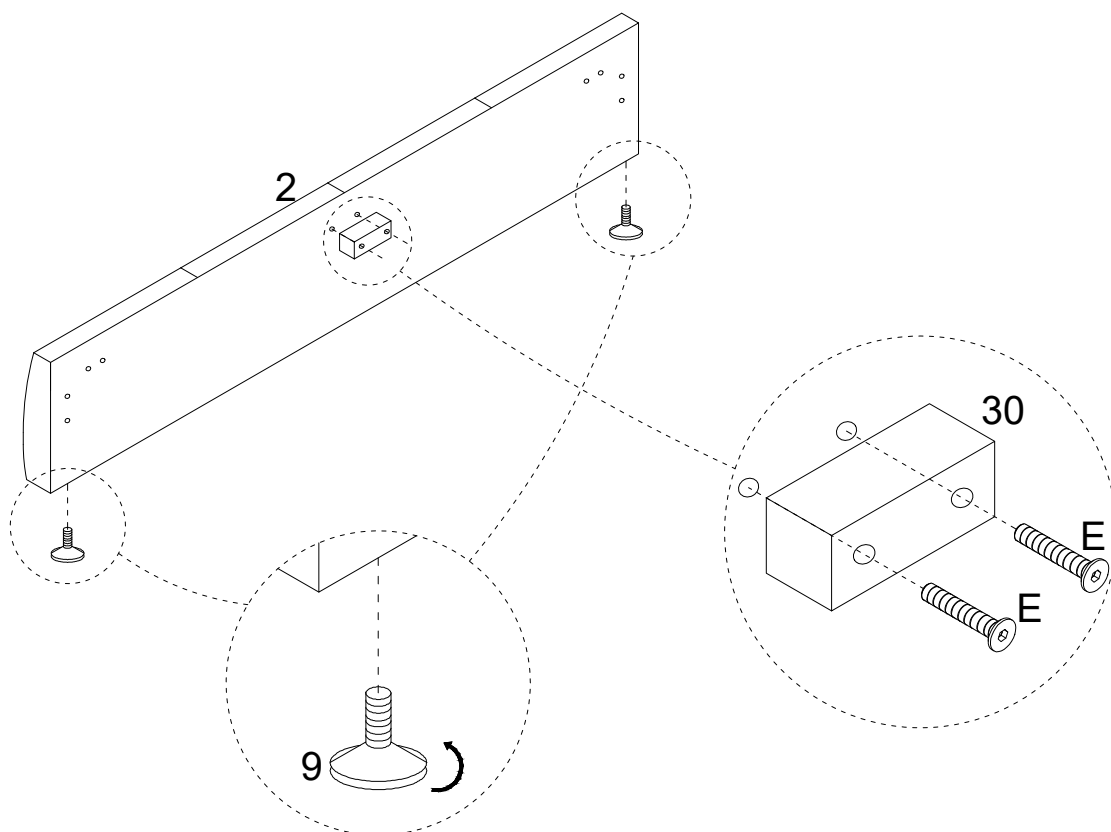

# MONTAGEANLEITUNG

Schritt:5

B x16pcs

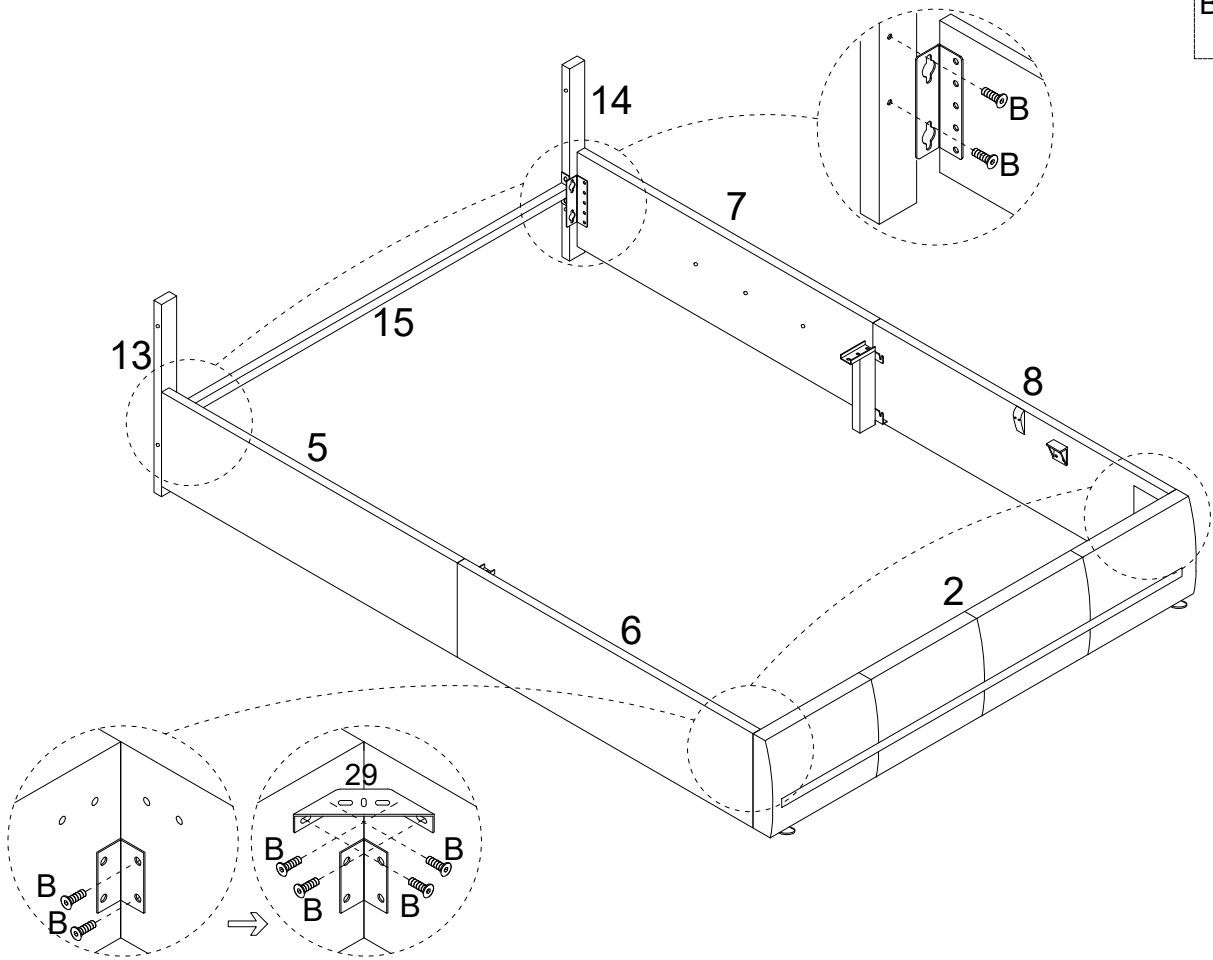

Schritt:6

F x4pcs

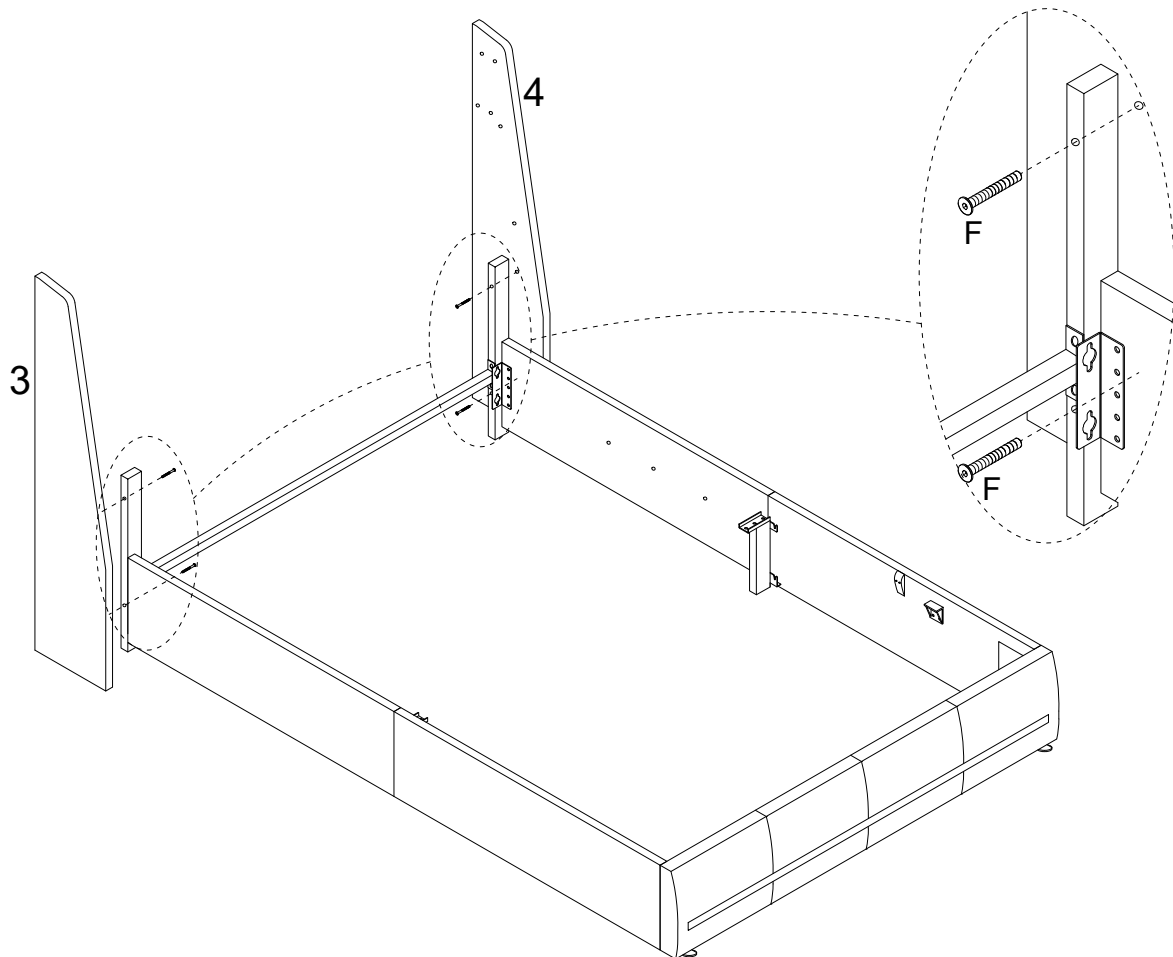

# MONTAGEANLEITUNG

Schritt:7

C x4pcs

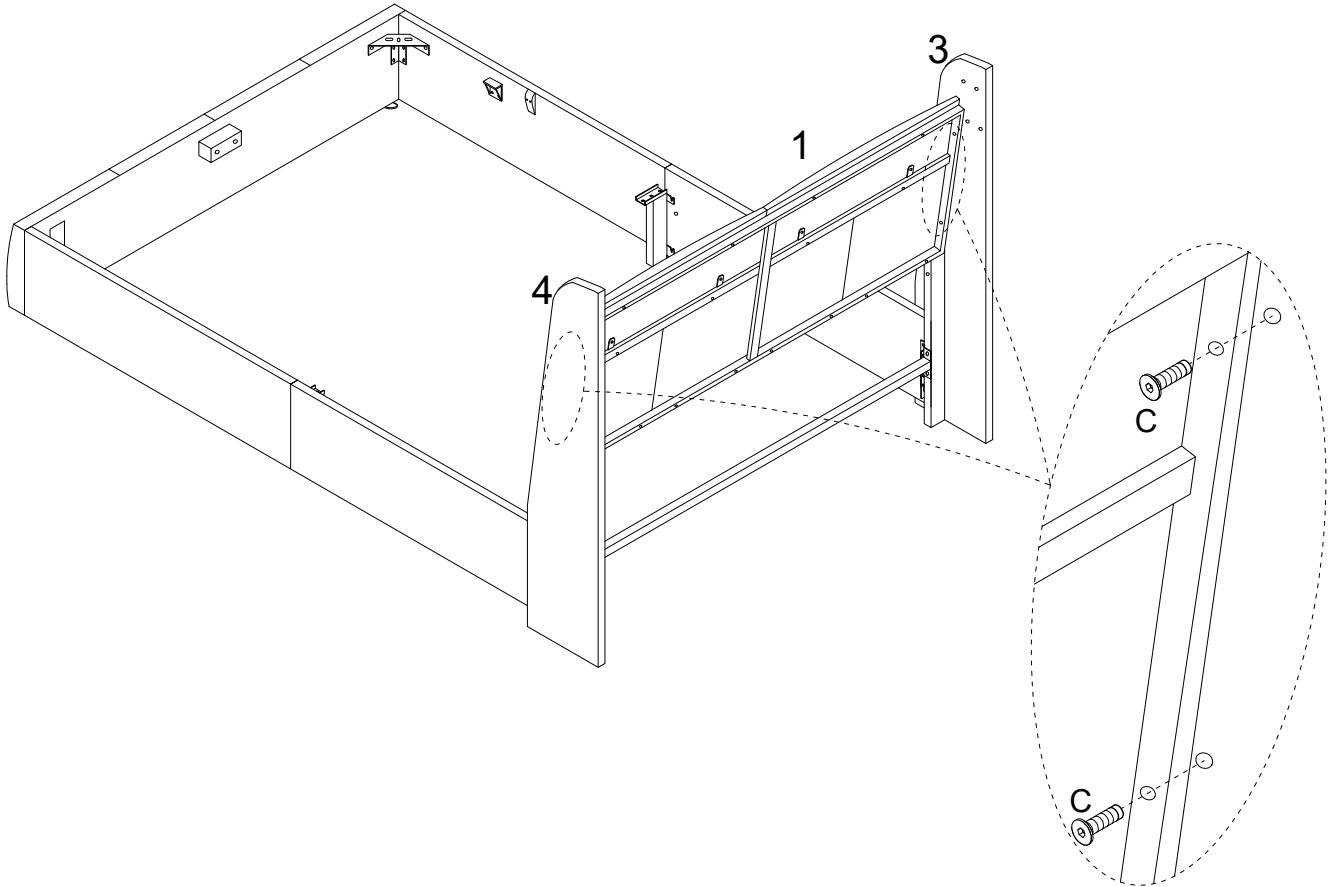

Schritt:8

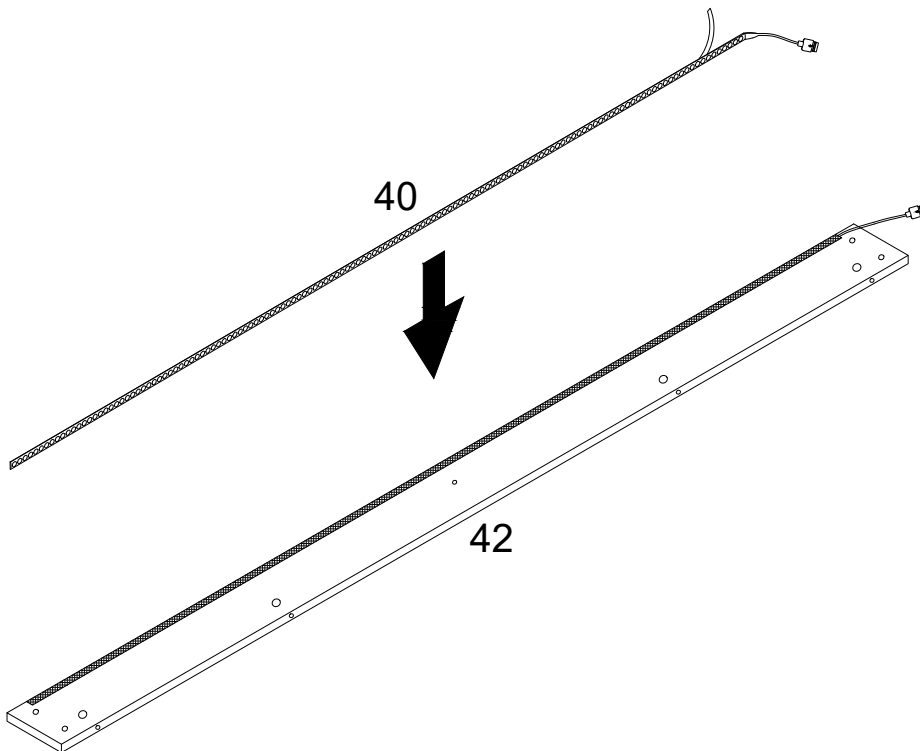

# MONTAGEANLEITUNG

## Schritt:9

A x8pcs

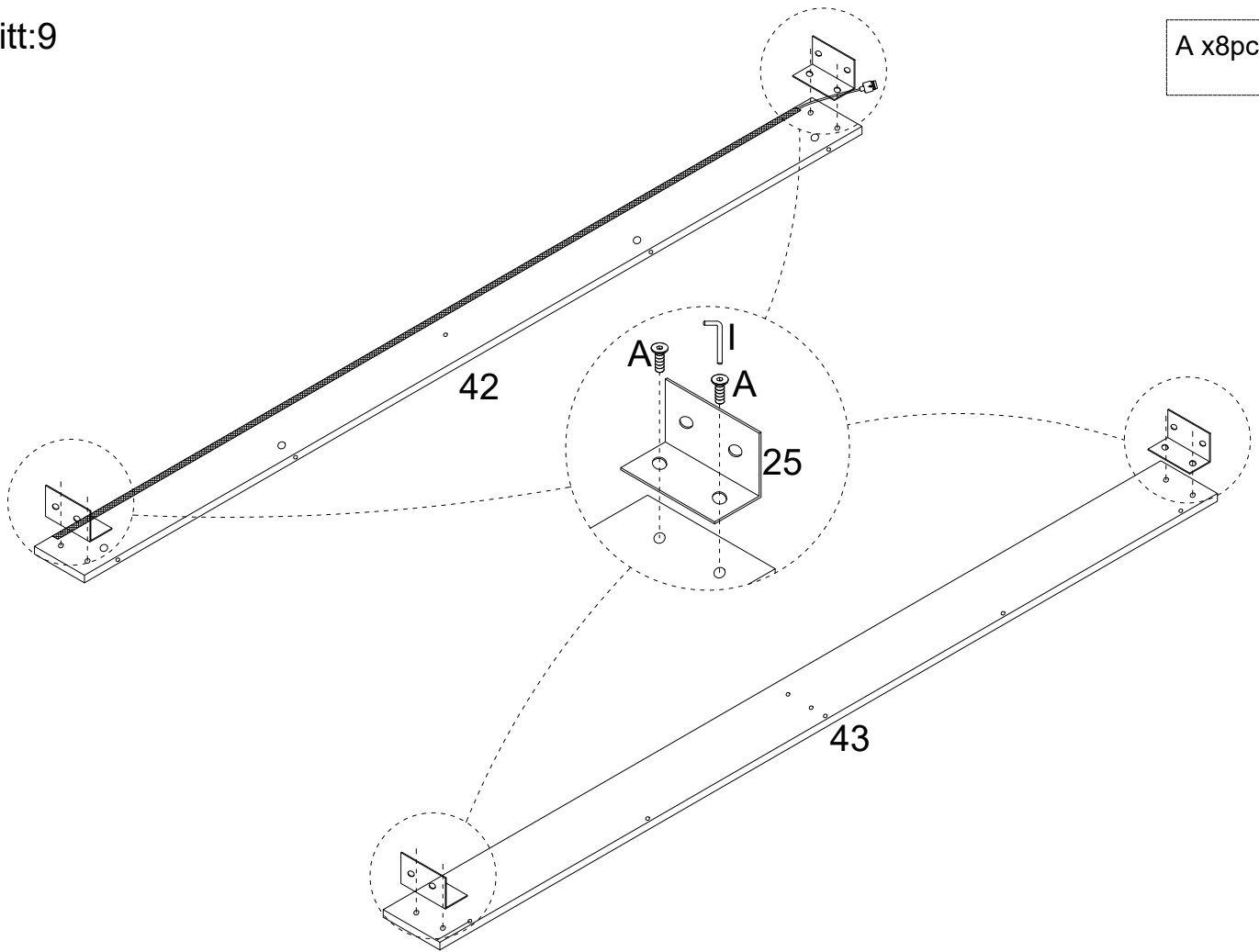

## Schritt:10

N x5pcs  
O x5pcs

There's an arrow on the nut. Please align the arrow with the side hole  
Da ist ein Pfeil auf der Nuss. Bitte richten Sie den Pfeil mit dem  
seitlichen Loch aus  
Ily a une flèche sur l'écrou. Veuillez aligner les flèches avec les trous  
latéraux

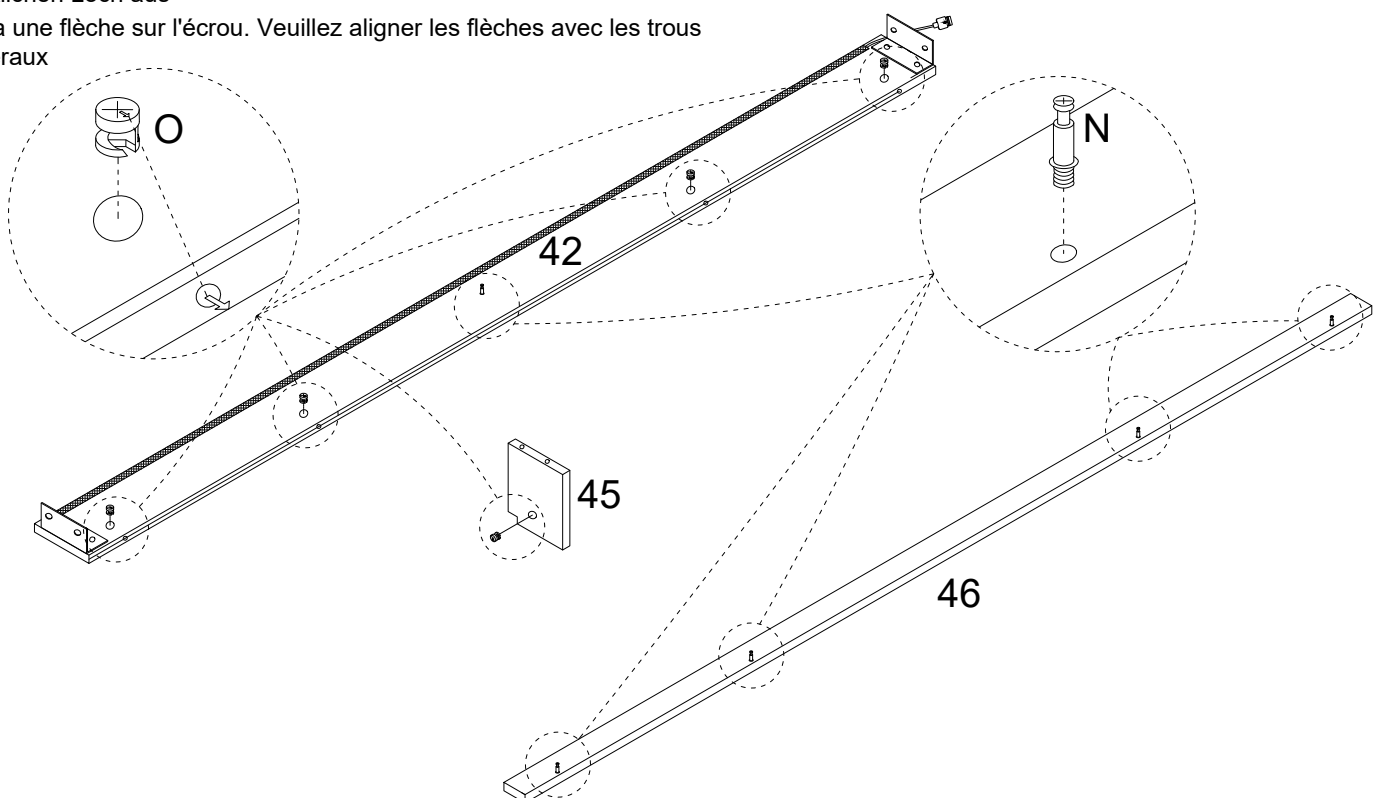

# MONTAGEANLEITUNG

## Schritt:11

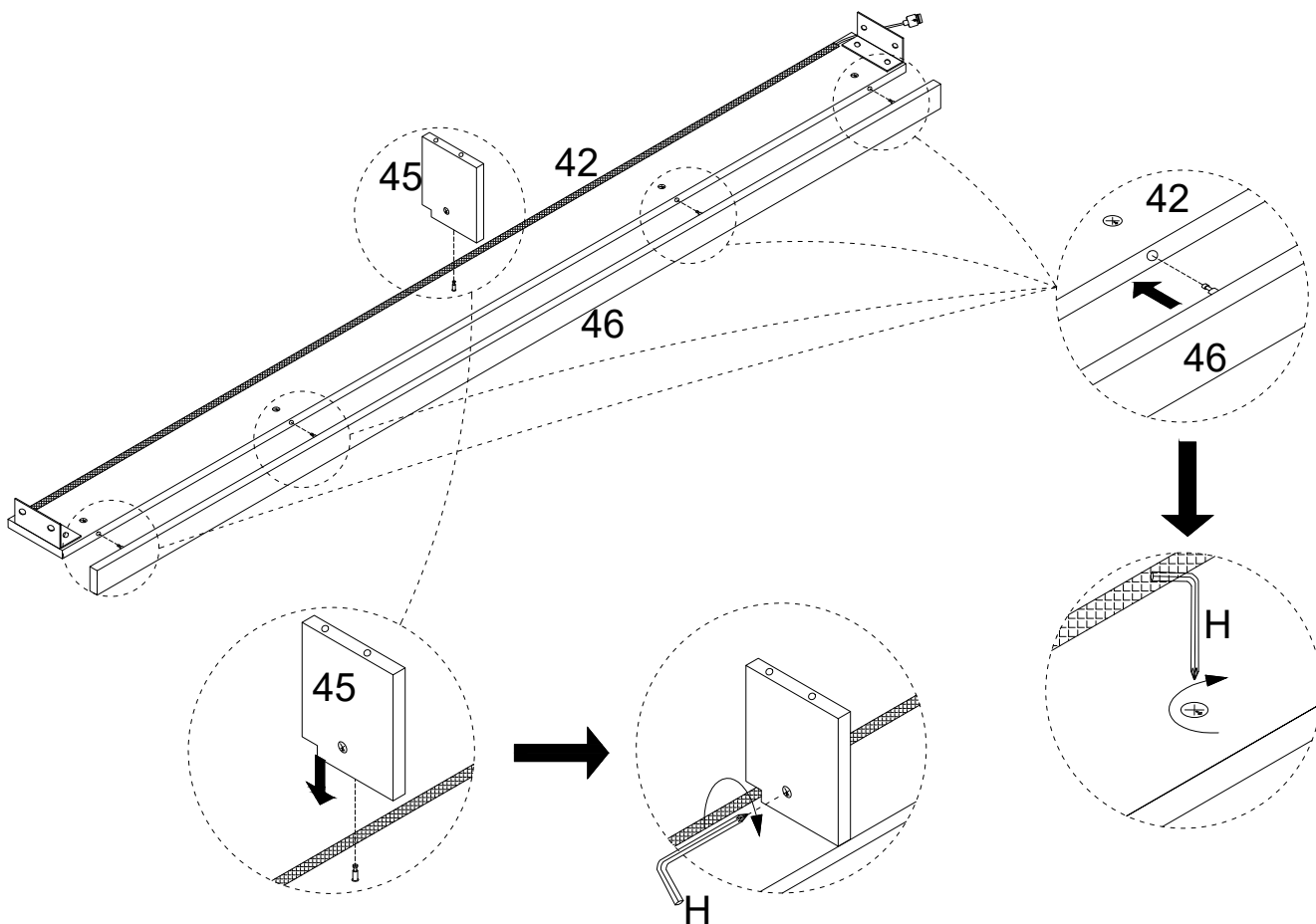

## Schritt:12

M x6pcs

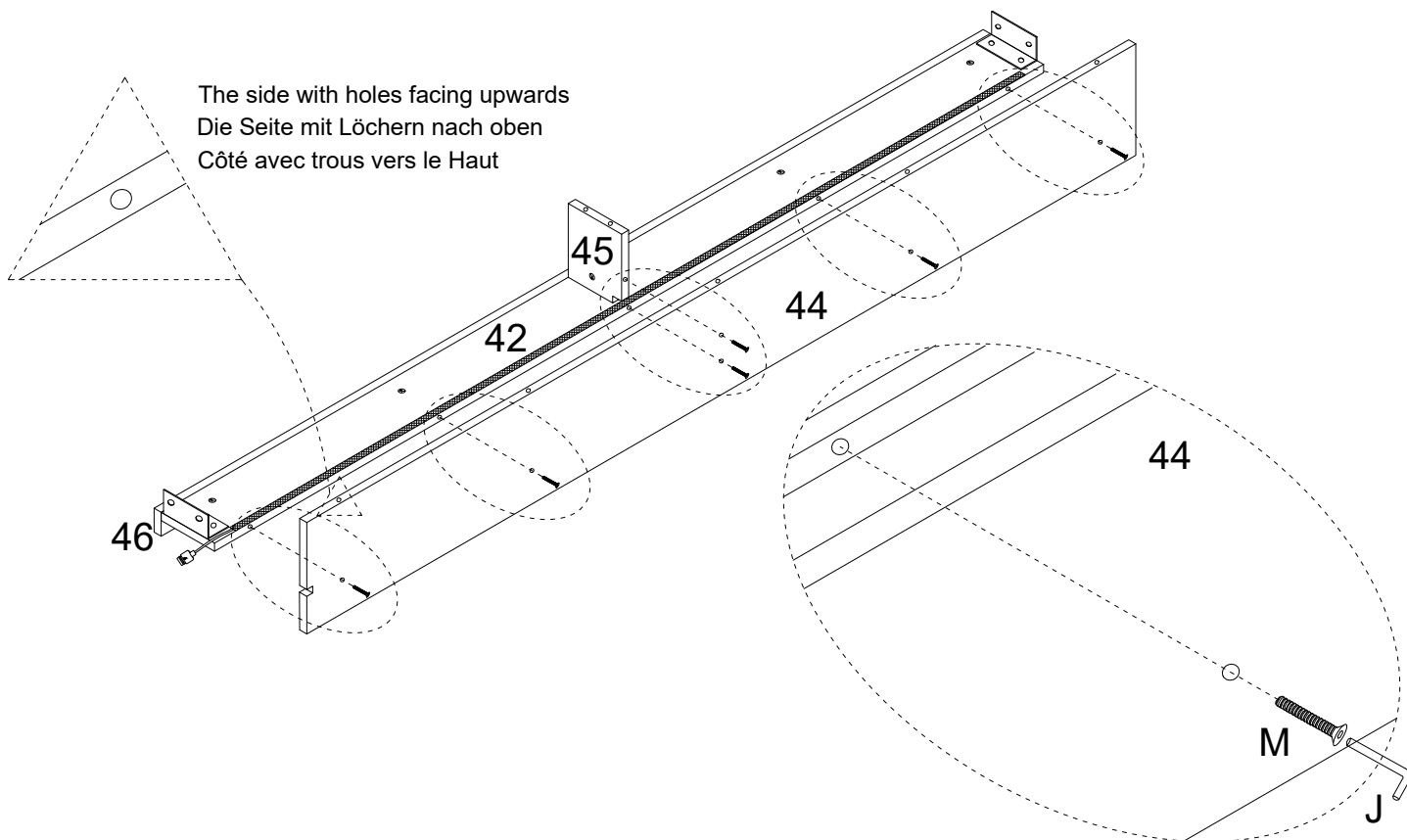



# MONTAGEANLEITUNG

Schritt:13

M x7pcs

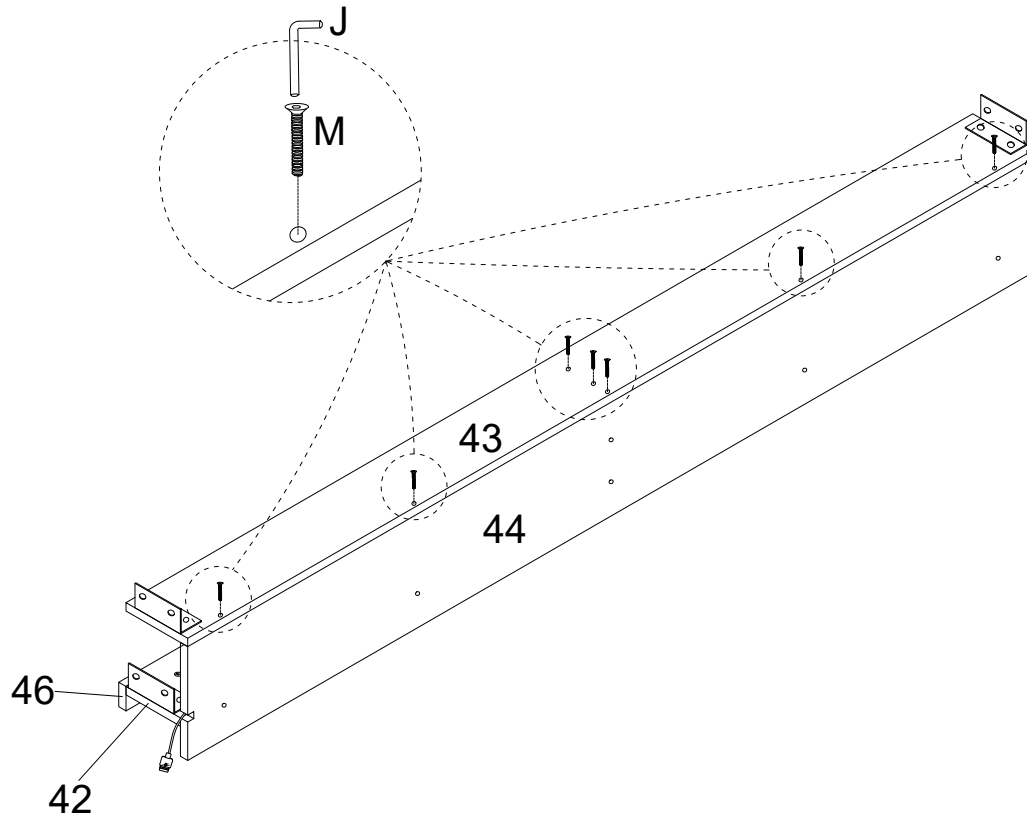

Schritt:14

B x4pcs

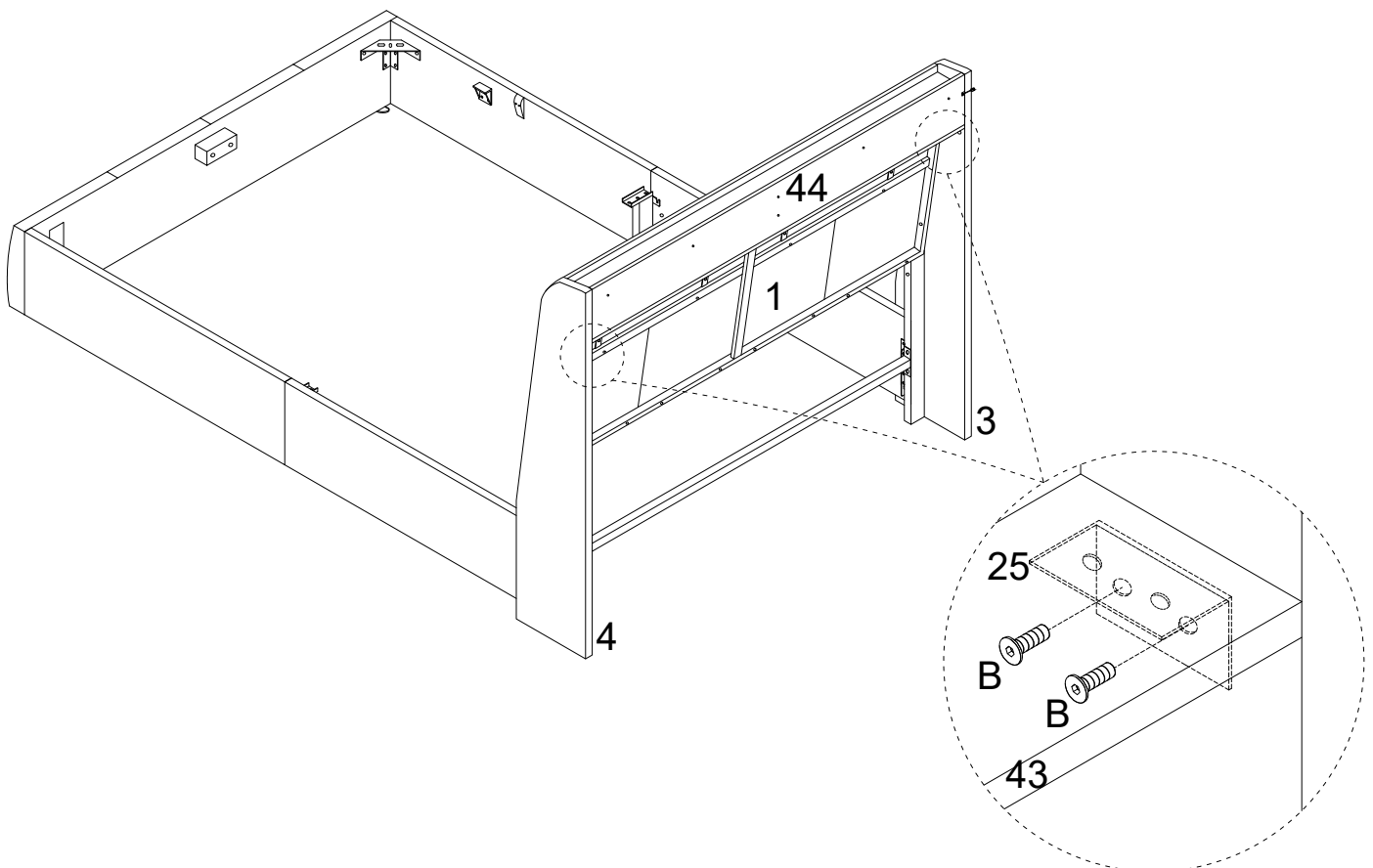

# MONTAGEANLEITUNG

Schritt:15

B x4pcs

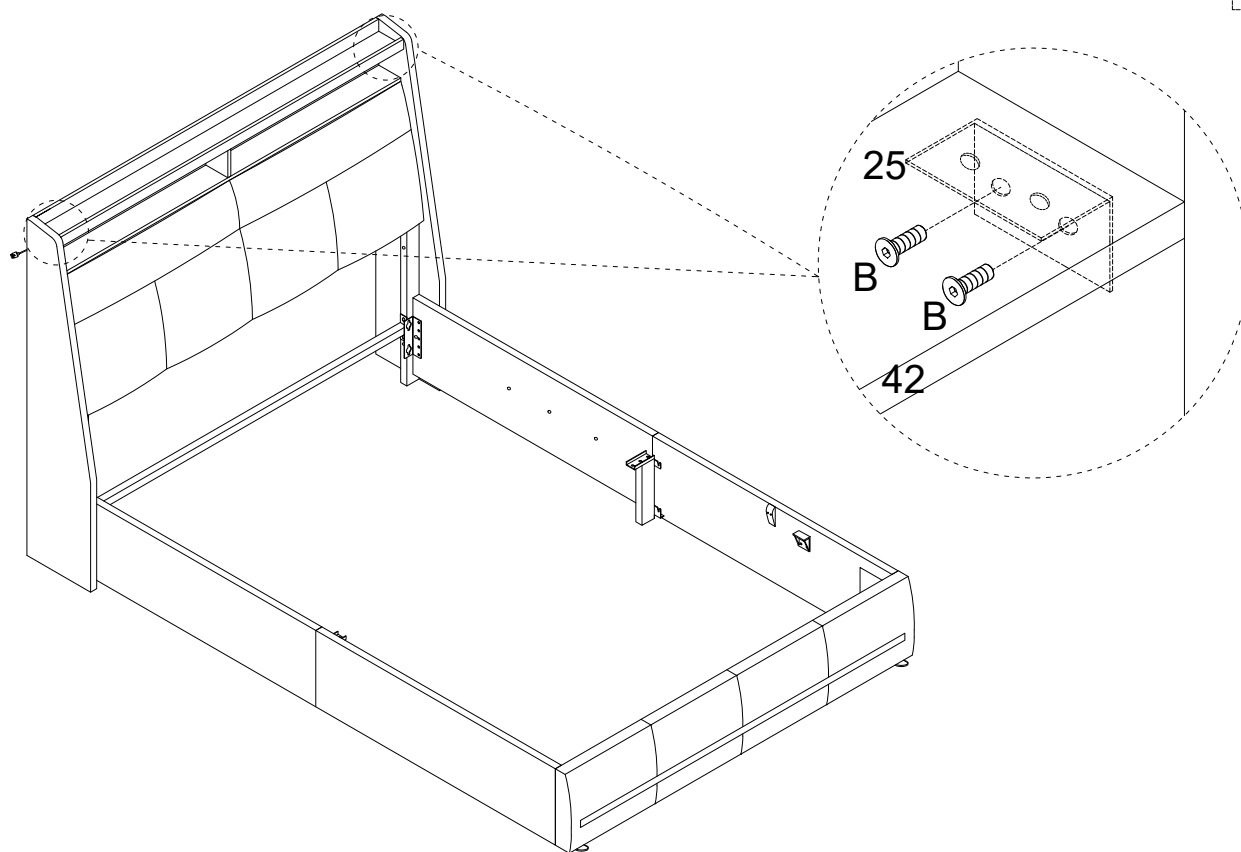

Schritt:16

B x2pcs  
D x2pcs

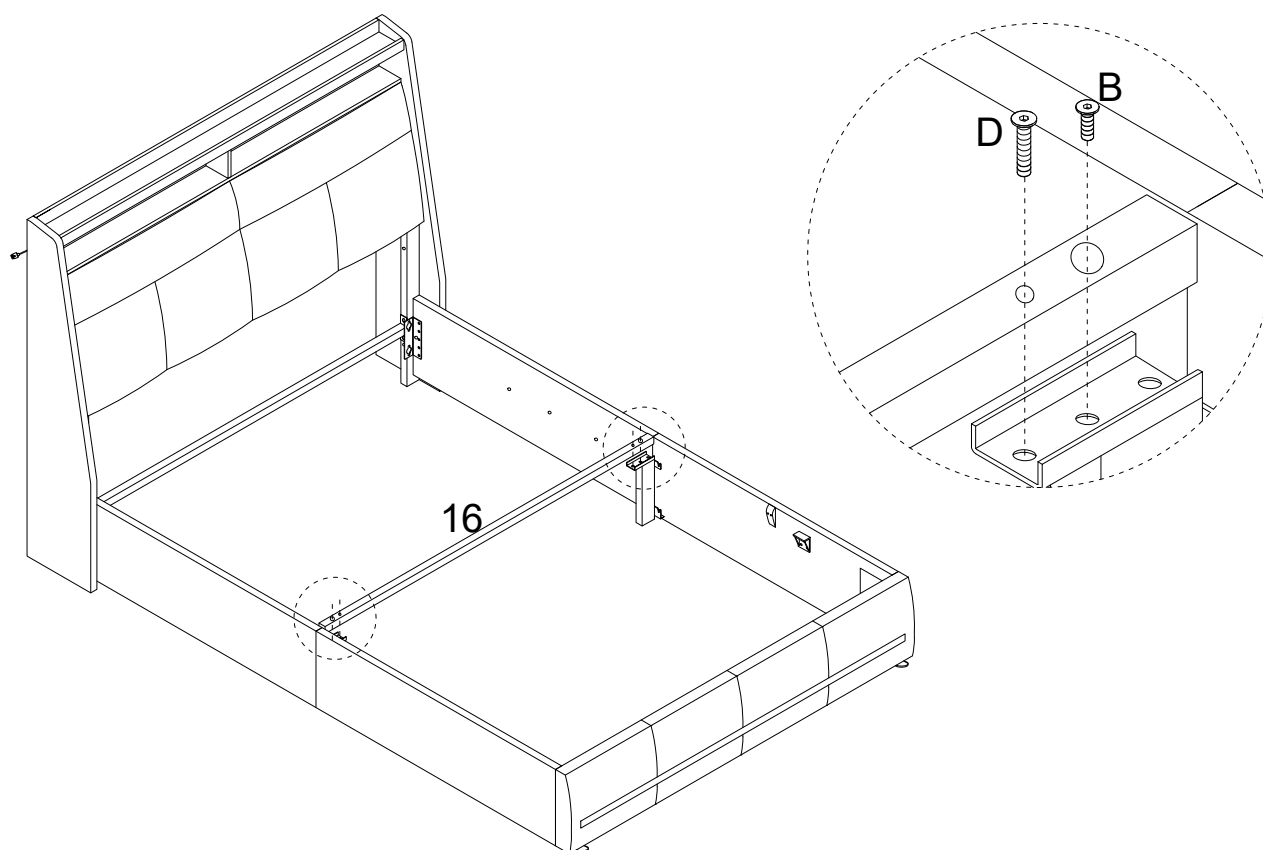

# MONTAGEANLEITUNG

Schritt:17

B x8pcs

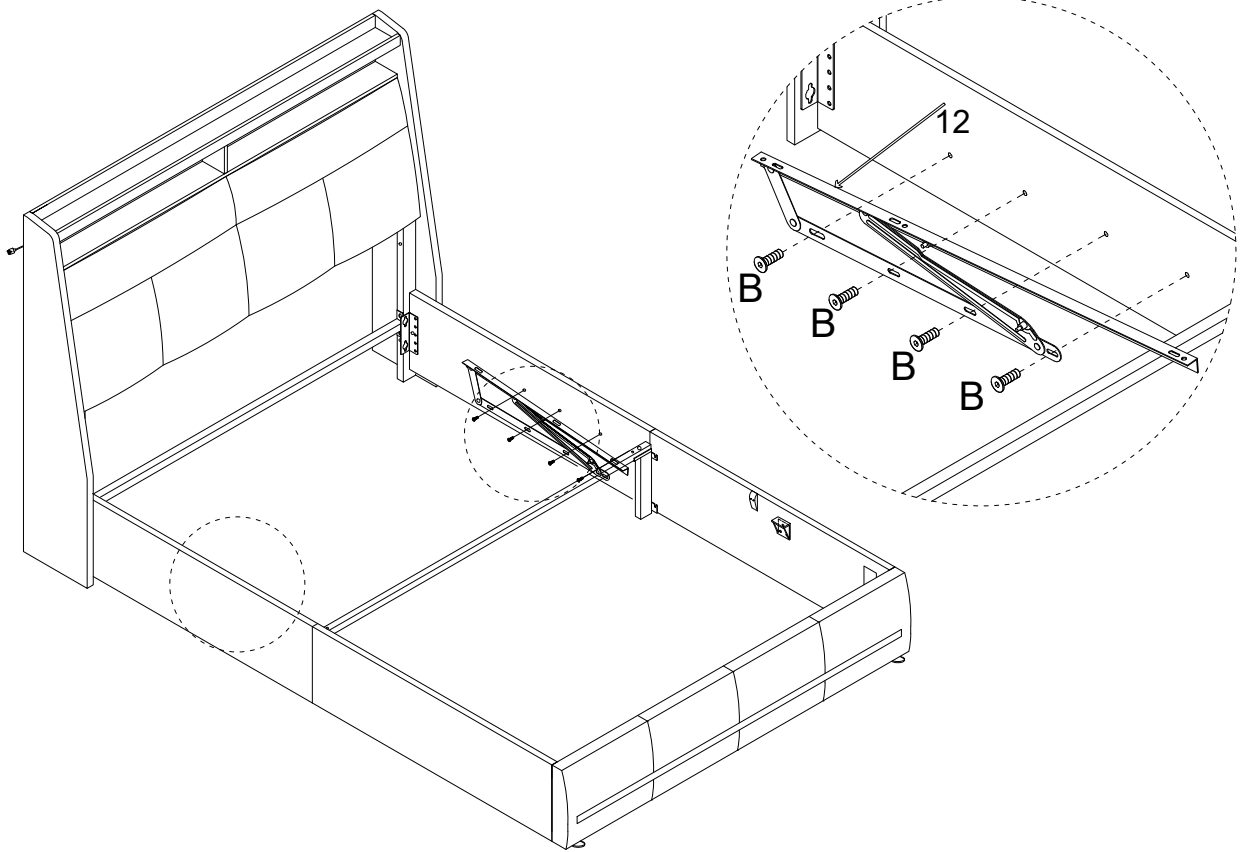

Schritt:18

D x3pcs

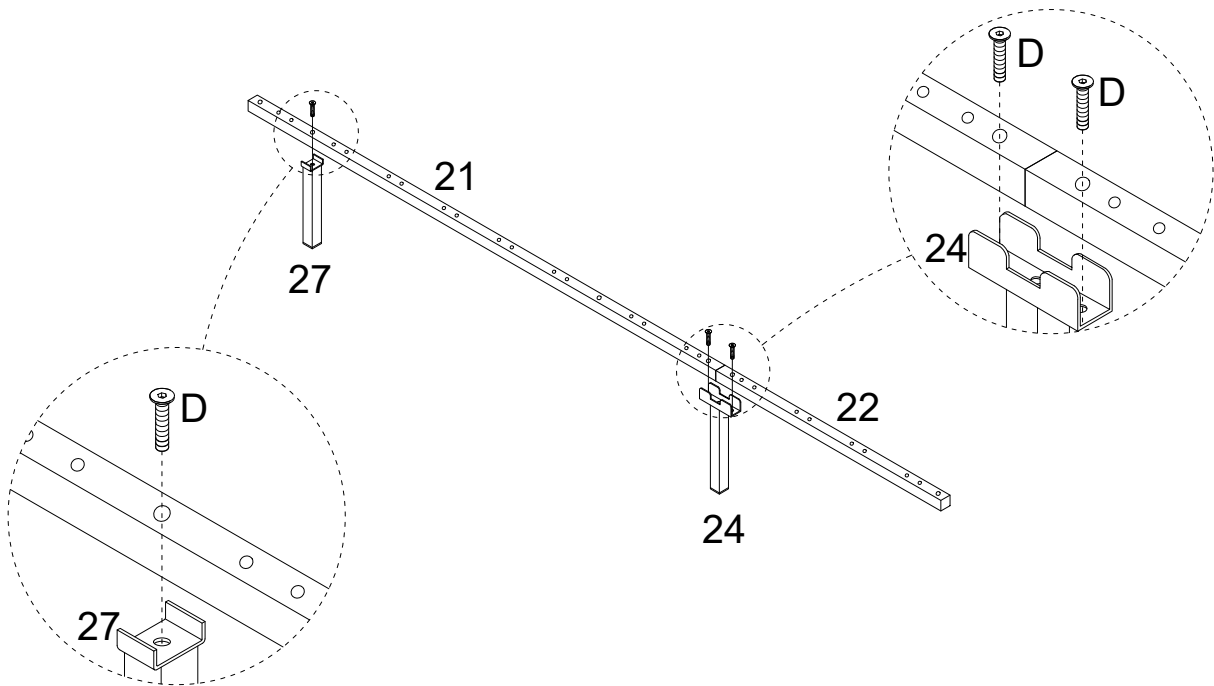

# MONTAGEANLEITUNG

Schritt:19

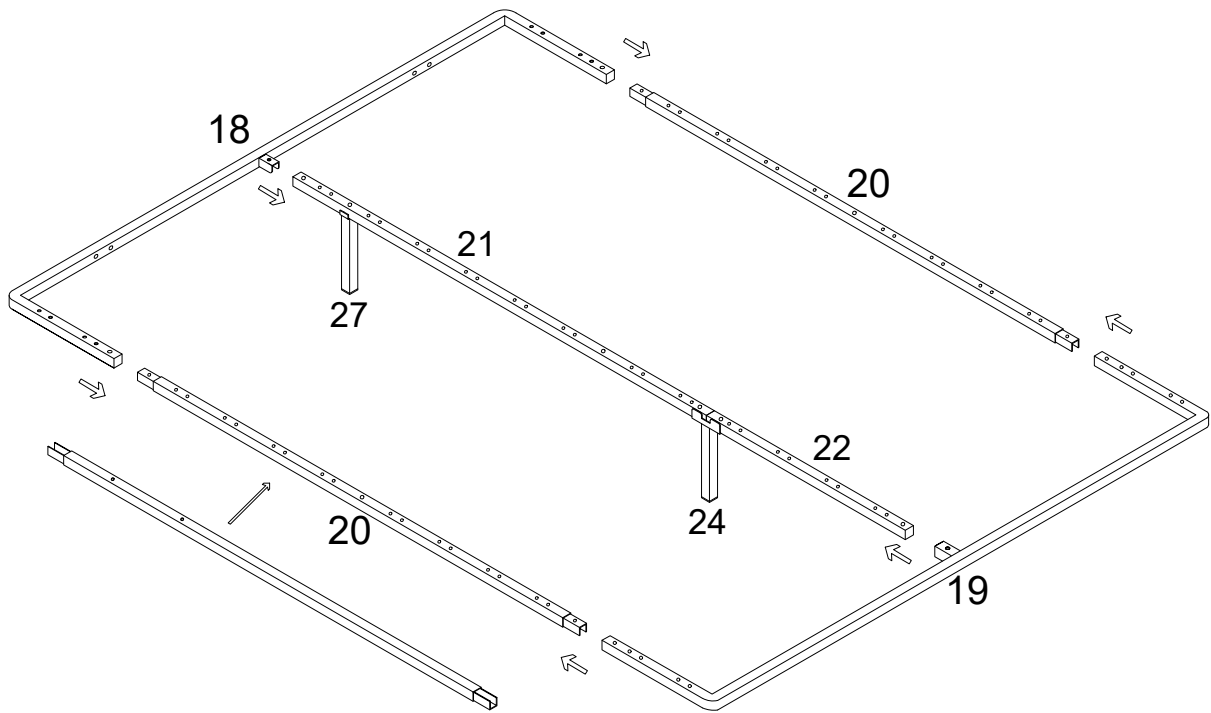

Schritt:20

B x6pcs

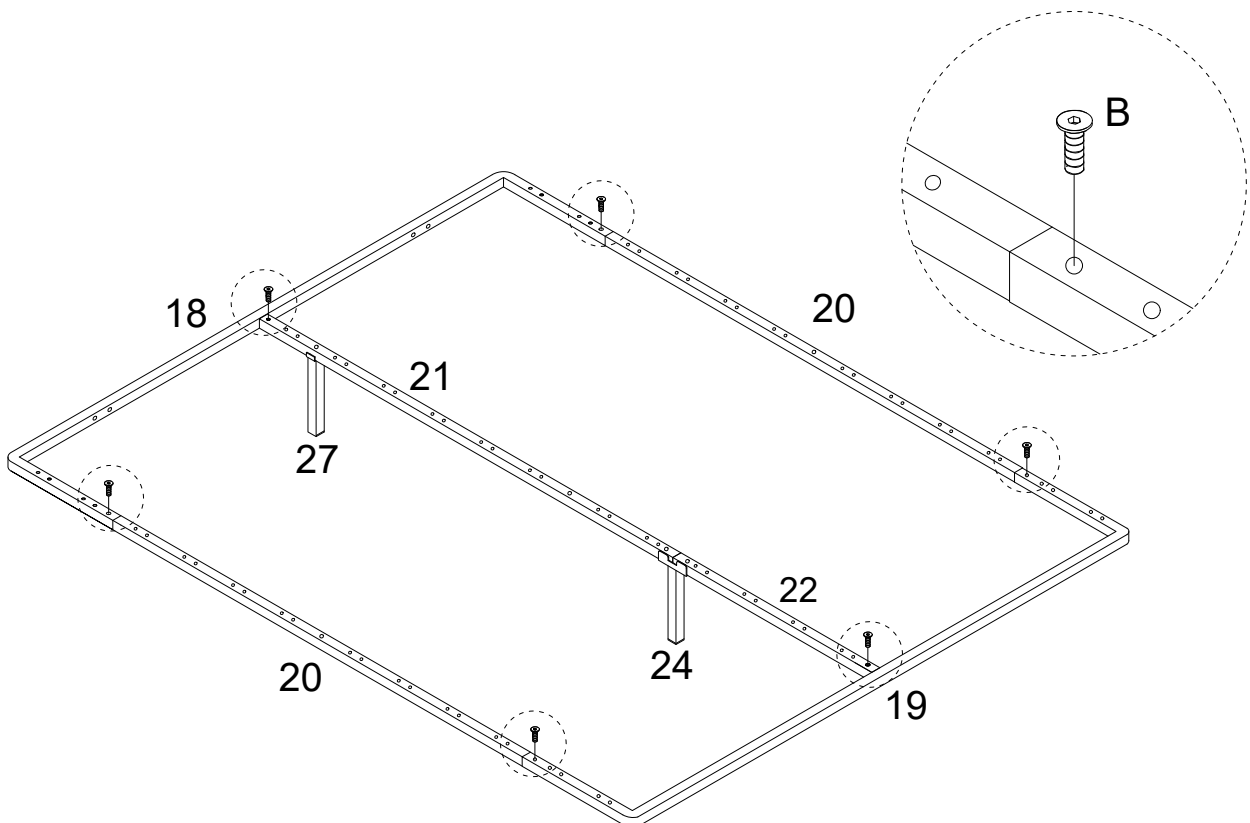

# MONTAGEANLEITUNG

Schritt:21

B x4pcs

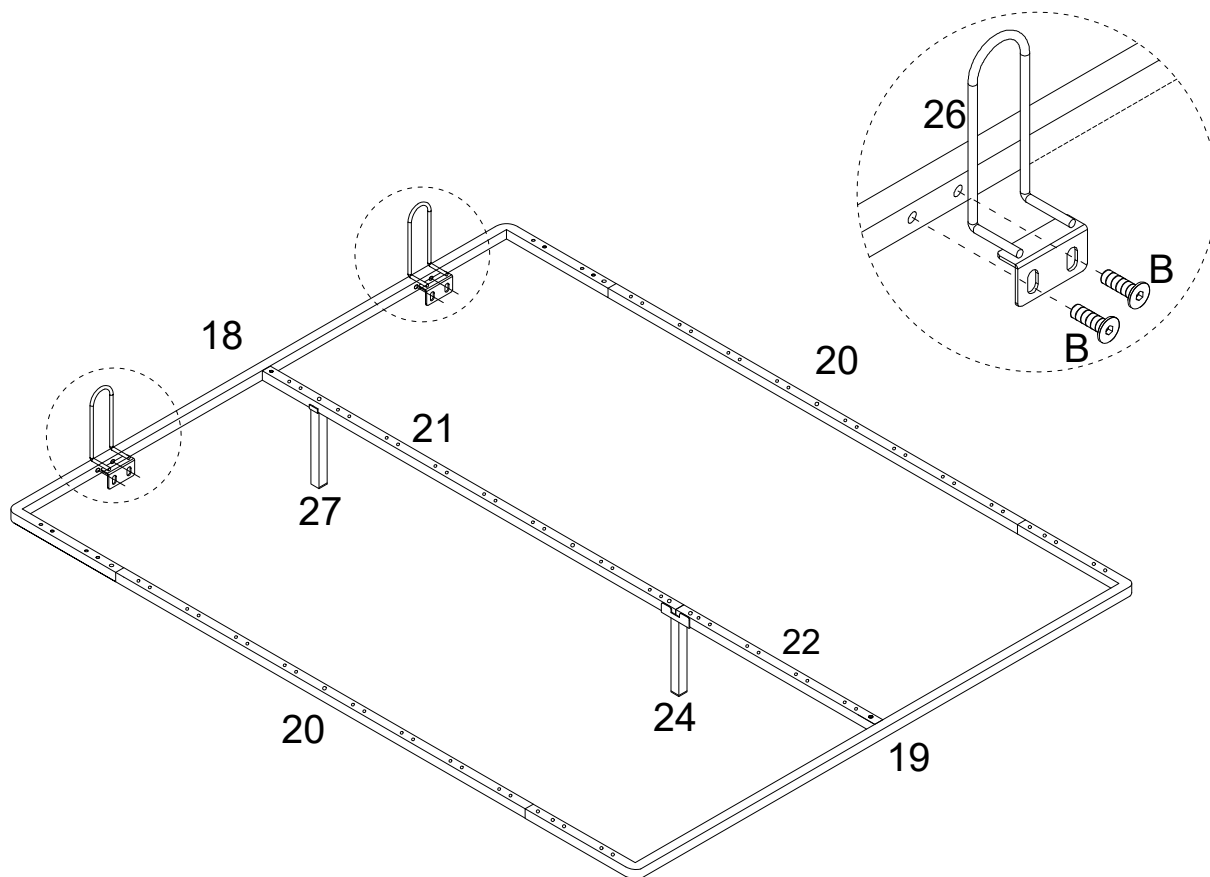

Schritt:22

C x3pcs

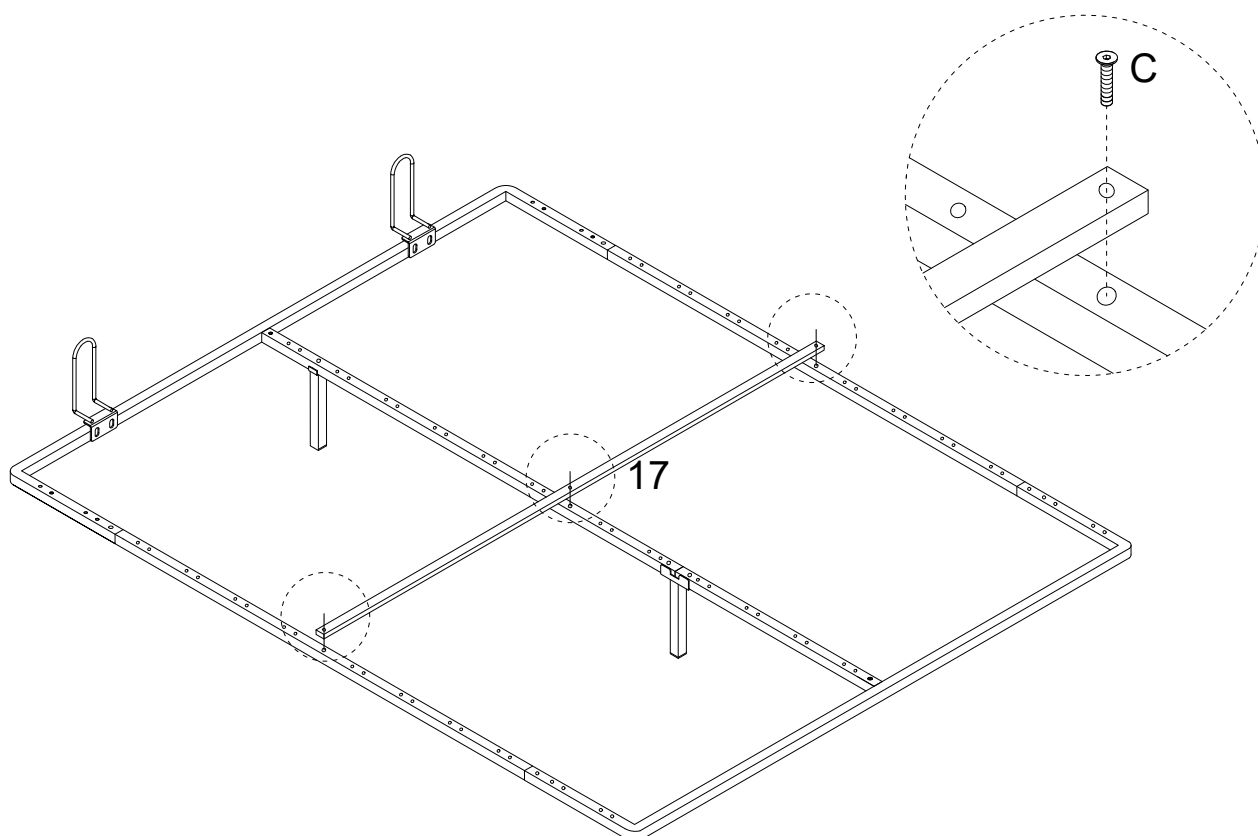



# MONTAGEANLEITUNG

## Schritt:25

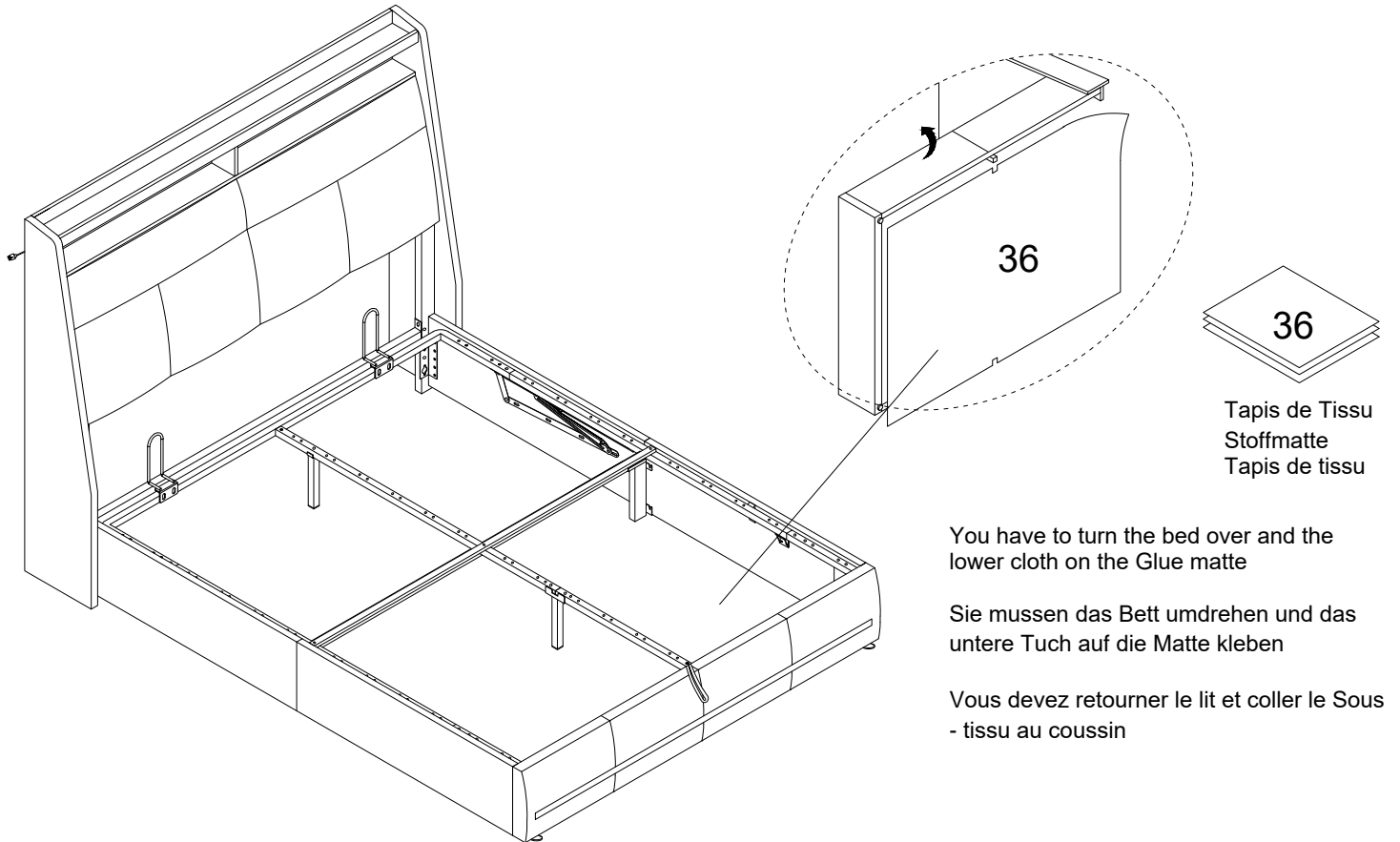

## Schritt:26

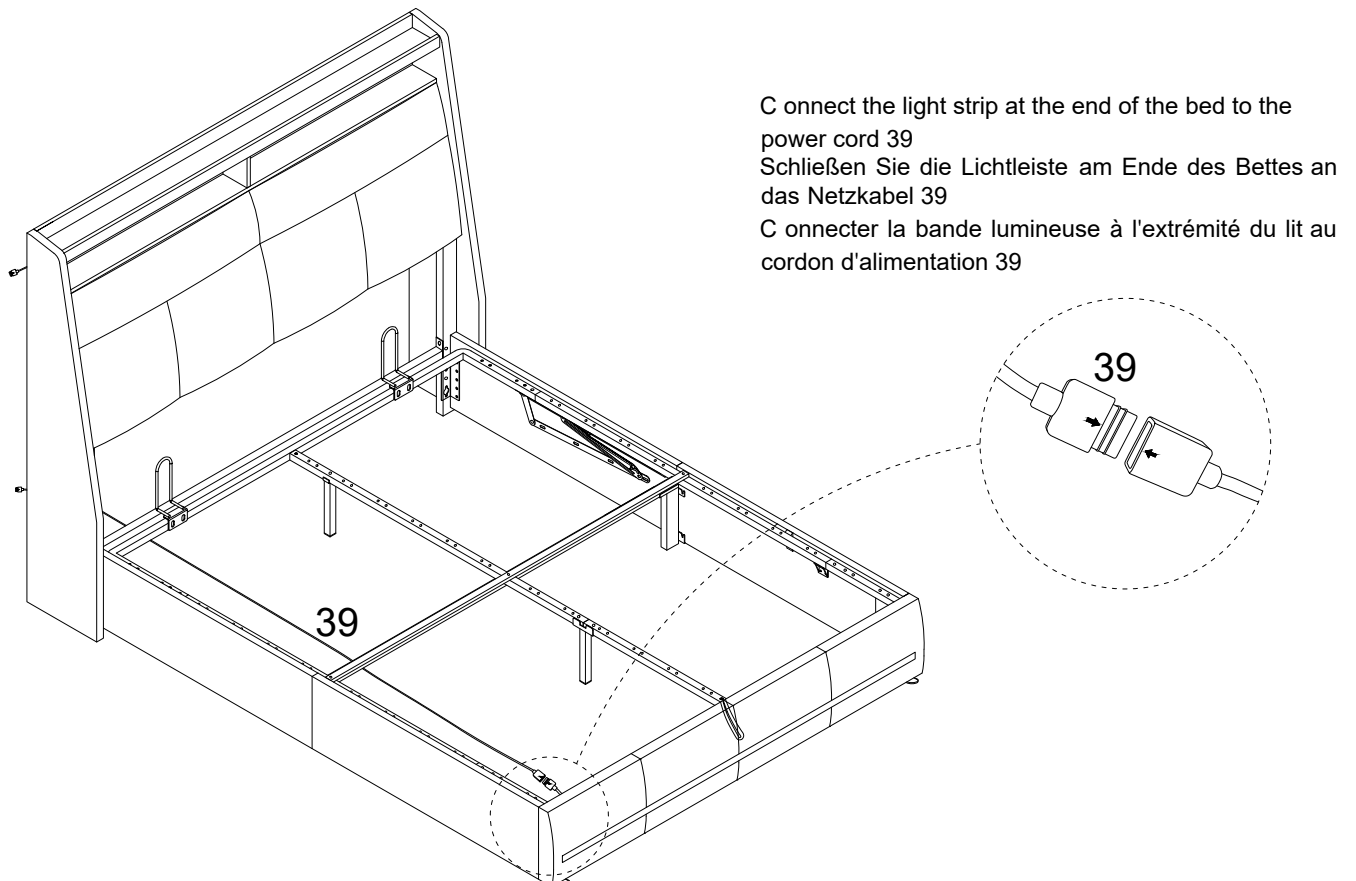

# MONTAGEANLEITUNG

## Schritt:27

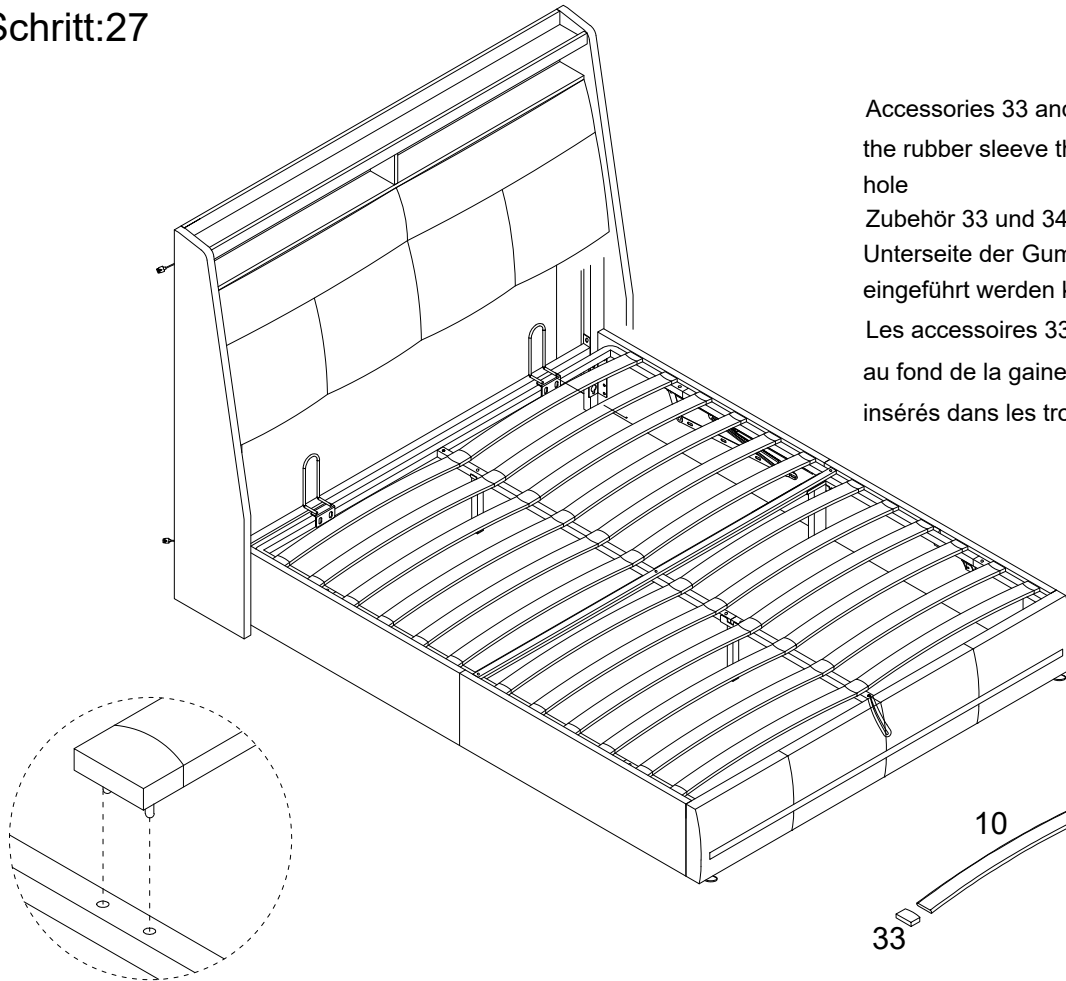

Accessories 33 and 34 have plastic plugs at the bottom of the rubber sleeve that can be inserted into the iron pipe hole

Zubehör 33 und 34 haben Kunststoffstopfen an der Unterseite der Gummihülse, die in das Eisenrohrloch eingeführt werden können

Les accessoires 33 et 34 ont des bouchons en plastique au fond de la gaine en caoutchouc qui peuvent être insérés dans les trous des tubes en fer

## Schritt:28

C onnect the light strip on the bedside table to the adapter 41

Schließen Sie die Lichtleiste am Nachttisch an den Adapter 41 an

C onnecter la bande lumineuse sur la table de chevet à l'adaptateur 41

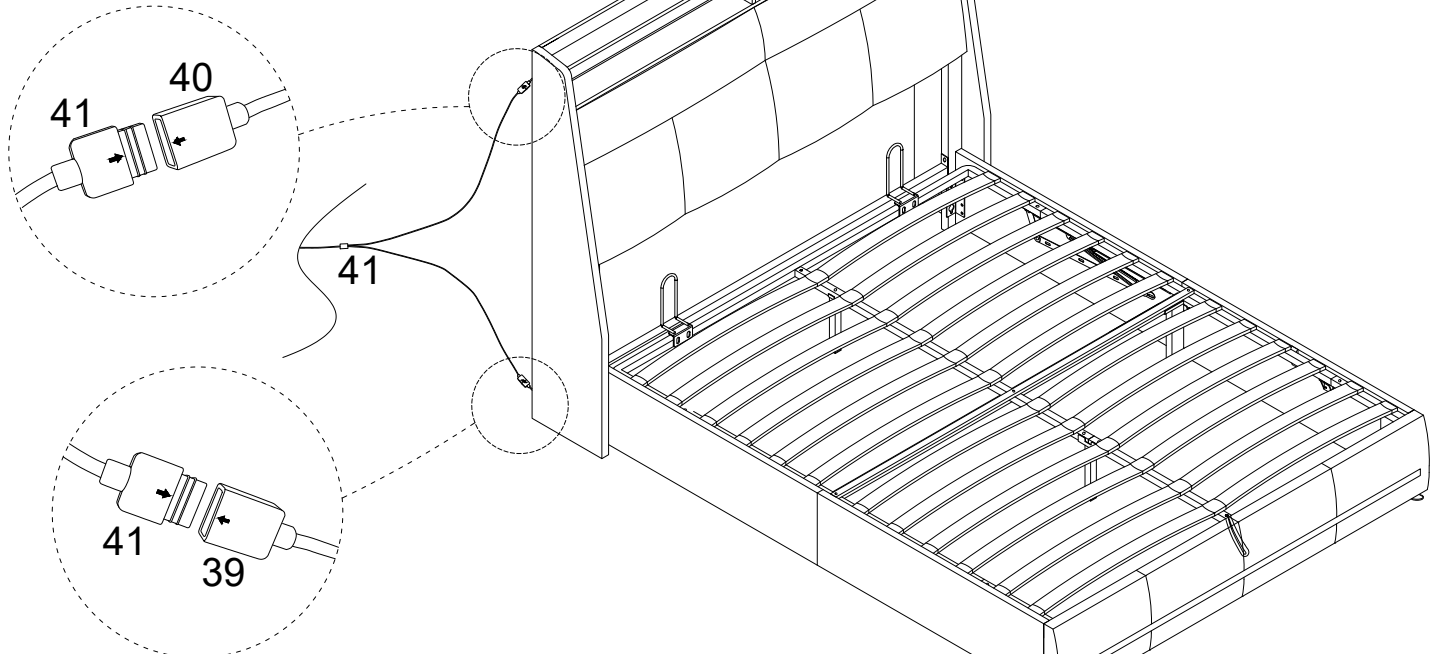

C onnect the 39-power cable and 41-adapter cable to C onnexion

Schließen Sie das 39-Netzkabel und das 41-Adapterkabel an C onnexion

39 câble d'alimentation et 41 câble adaptateur



# MONTAGEANLEITUNG

## Schritt:29

NO.1

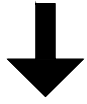
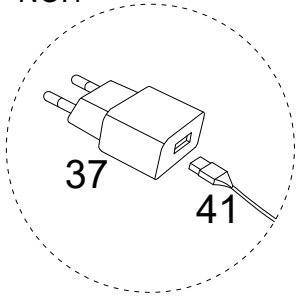

NO.2

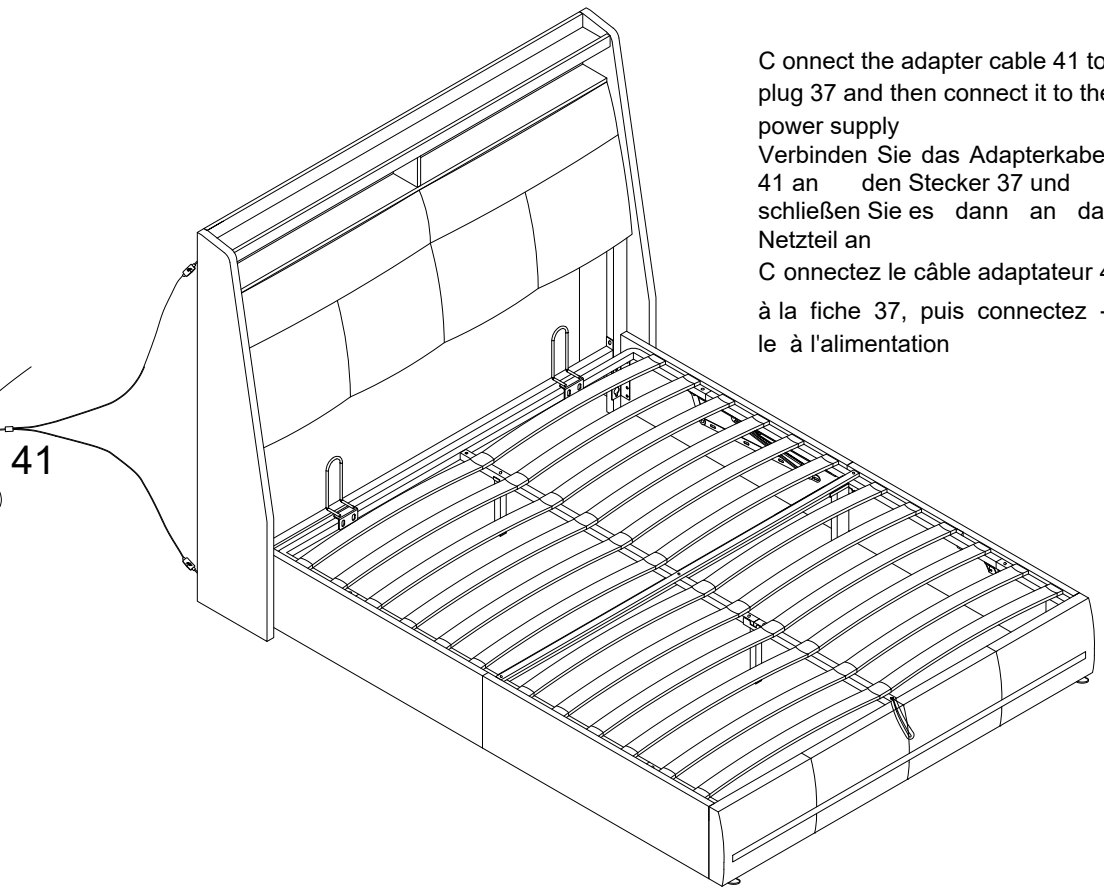
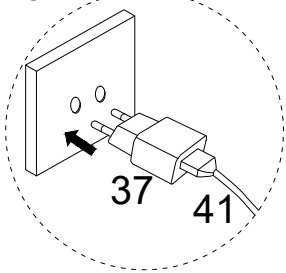

Connect the adapter cable 41 to plug 37 and then connect it to the power supply  
Verbinden Sie das Adapterkabel 41 an den Stecker 37 und schließen Sie es dann an das Netzteil an  
Connectez le câble adaptateur 41 à la fiche 37, puis connectez - le à l'alimentation

## Schritt:30

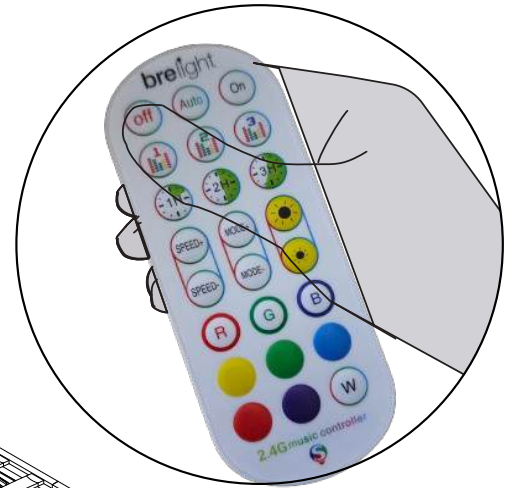
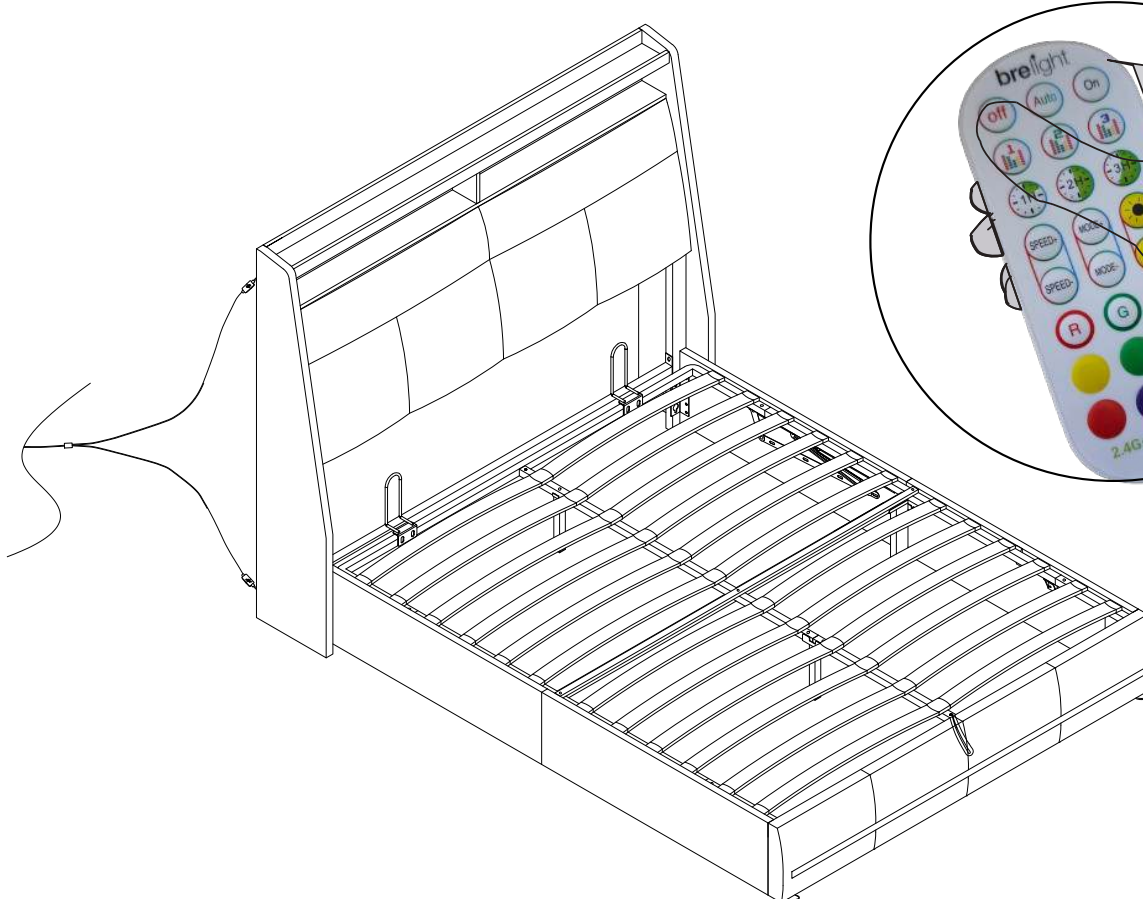

# MONTAGEANLEITUNG

## IMPORTANT NOTE/ WICHTIGER HINWEIS/ Conseils importants

### Mattresses Owner's Manual/ Matratzen Bedienungsanleitung/ Manuel d'utilisation matelas

Once your bed frame is fully assembled, the slatted unit will not work properly unless a mattress is placed on the slatted frame. Place the mattress in a closed position on the slatted frame.

**PLEASE NOTE** -The initial movement of the mattress requires a lot of force. This is a design feature of the product, so it is not closed. The closer the mattress closes, the easier it is to move. When the mattress is almost closed, it closes completely under the effect of its weight. When lowering the mattress device for the first time, it is important to ensure that they do not rub evenly on the inside of the side beam. If yes, this is that the bed assembly is a bit inappropriate. This can be corrected by moving the foot of the bed slightly to the left or right and keeping the head still.

Sobald Ihr Bettrahmen komplett montiert ist, funktioniert die Latteneinheit nicht richtig, es sei denn, eine Matratze wird auf dem Lattenrahmen platziert. Legen Sie die Matratze in geschlossener Position auf den Lattenrost.

**BITTE BEACHTEN** -Die anfängliche Bewegung der Matratze erfordert viel Kraft. Dies ist ein Design-Merkmal des Produkts, so dass es nicht geschlossen wird. Je näher die Matratze schließt, je einfacher es ist, sich zu bewegen. Wenn die Matratze fast geschlossen ist, schließt es sich vollständig unter der Wirkung seines Gewichts. Beim ersten Senken der Matratzenvorrichtung ist es wichtig, sicherzustellen, dass sie nicht gleichmäßig auf der Innenseite des Seitenstrahls reiben. Wenn ja, das ist, dass die Bettmontage ein bisschen unangebracht ist. Dies kann korrigiert werden, indem Sie den Fuß des Bettes leicht nach links oder rechts bewegen und den Kopf still halten.

Une fois que votre cadre de lit est entièrement assemblé, le cadre à lattes ne fonctionnera pas correctement à moins qu'un matelas ne soit placé sur le cadre à lattes. Placez le matelas en position fermée sur le cadre à lattes.

**Remarque** - le mouvement initial du matelas nécessite beaucoup de force. C'est une caractéristique de conception de ce produit, de sorte qu'il ne se ferme pas. Plus le matelas se ferme, plus il est facile de se déplacer. Lorsque le matelas est presque fermé, il se ferme complètement sous l'effet de son poids. Lorsque vous abaissez les unités de matelas pour la première fois, il est important de vous assurer qu'elles ne frottent pas uniformément à l'intérieur des longerons. Si oui, c'est parce que les composants du lit sont un peu inappropriés. Cela peut être corrigé en déplaçant légèrement le pied du lit vers la gauche ou la droite et en gardant la tête immobile.

## Piston/ Kolben/ La bouteille

The piston used in this product structure is very robust and cannot be operated manually when removed from a footrest. Before connecting all pistons to the seam unit, check that the pressure and operation are correct. At first, the piston can appear very stiff when opening and closing the footstools.

**That's perfectly normal.**

Lift and place the footstool 4/5 times when the mattress is fully assembled and the mattress is on the floor. To ensure that the gas piston is fully lubricated.

Der Kolben, der in dieser Produktstruktur verwendet wird, ist sehr robust und kann nicht manuell betrieben werden, wenn er von einer Fußstütze entfernt wird. Bevor Sie alle Kolben an die Nahteinheit anschließen, prüfen Sie, ob der Druck und der Betrieb korrekt sind. Zunächst kann der Kolben sehr steif erscheinen, wenn er die Fußhocker öffnet und schließt.

**Das ist vollkommen normal.**

Heben und legen Sie den Fußhocker 4/5 mal auf, wenn die Matratze vollständig zusammengebaut ist und die Matratze auf dem Boden ist. Um sicherzustellen, dass der Gaskolben vollständig geschmiert ist.

Les Pistons utilisés dans la construction de ce produit sont si robustes qu'ils ne peuvent pas être actionnés manuellement lorsqu'ils sont retirés du repose - pieds. Vérifiez que la pression et le fonctionnement sont corrects avant de connecter tous les pistons à l'unité de couture. Au début, le piston peut sembler très rigide lors de l'ouverture et de la fermeture du repose - pieds.

**C'est normal.**

Lorsque le matelas est entièrement assemblé et que le matelas est sur le sol, soulevez et placez le repose - pieds 4 / 5 fois. Assurez - vous que le piston de gaz est bien lubrifié.

