

1YYASC45/1PPASC45

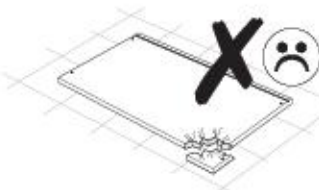

200 min

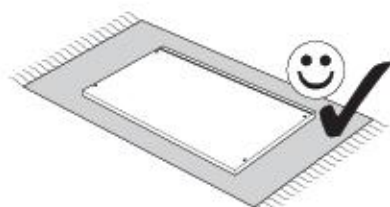

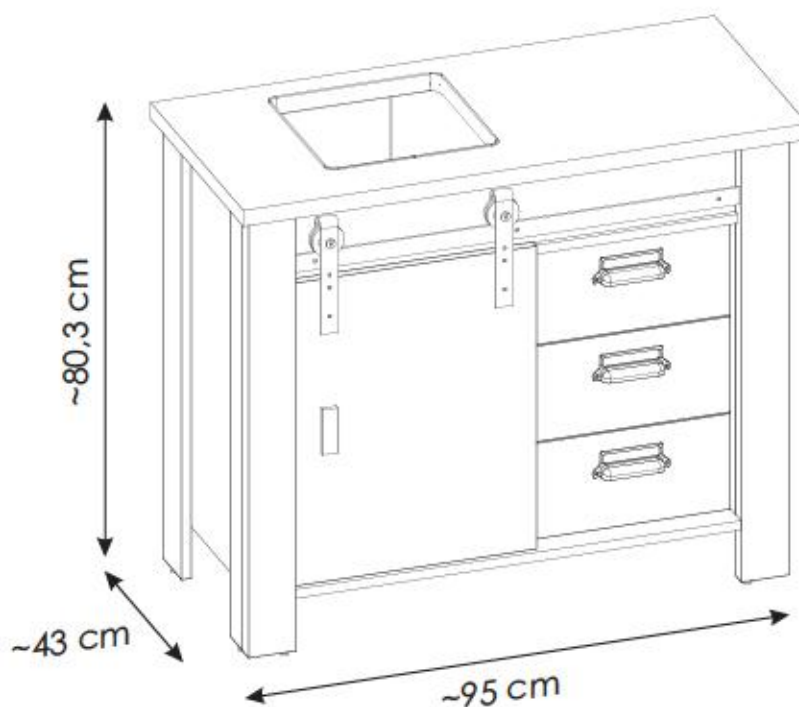
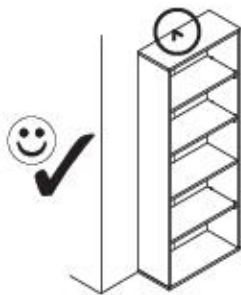

PL

UWAGA! Mebel należy trwale zamocować do ściany, aby uniknąć ryzyka związanego z przewróceniem się mebla. W paczce nie ma śrub mocujących, ponieważ rodzaj mocowania należy odpowiednio dobrać do rodzaju ściany. Dobierz właściwe do Twojego rodzaju ściany.

D.

ACHTUNG! Um alle mit dem Umkippen des Möbels verbundenen Risiken auszuschließen, muss das Möbel fest an der Wand verankert werden. Beschläge für die Wandbefestigung sind nicht beige packt, da diese von der jeweiligen Wandbeschaffenheit abhängig sind. Bitte solche Befestigungsschläge wählen, die für die heimischen Wände geeignet sind.

FR.

ATTENTION! Ce meuble doit être fixé en permanence au mur pour éviter les risques de chute. Les vis de fixation ne sont pas livrées car le type de fixation doit être choisi en fonction du type de mur. Sélectionnez les fixations adaptées au mur.

I.

ATTENZIONE! Il mobile deve essere permanentemente fissato alla parete per evitare i rischi derivanti da un ribaltamento del mobile. La confezione non include le viti di fissaggio, in quanto il tipo di fissaggio deve essere scelto in base al tipo di parete. Utilizzare viti appropriate in base al materiale della parete.

HR.

NAPOMENA! Namještaj mora biti trajno pričvršćen za zid, kako bi se izbjegao rizik od njegovog prevrtanja. U paketu nema vijaka za pričvršćivanje, jer se vrsta montaže mora prilagoditi vrsti zida. Odaberite pravu vrstu prema Vašoj vrsti zida.

EN.

WARNING! To prevent this furniture from tripping over, fix it to the wall permanently. Fixing devices are not included since different wall materials require different types of fixing devices. Please make sure you chose the correct ones for your type of wall.

SK.

POZOR! Nábytok musí byť trvalo pripevnený k stene tak, aby sa zamedzilo riziku prevrátenia. Balík neobsahuje upevňovacie skrutky, pretože typ upevnenia je treba vybrať podľa typu steny. Vyberte typ vhodný pre Vašu stenu.

CZ.

POZOR! Nábytek je nutné pevně připevnit ke zdi, abychom se vyhnuli riziku spojenému s jeho převrnutím. Součástí balení nejsou připevňovací šrouby, protože způsoby připevnění je nutné zvolit podle druhu stěny. Vyberte správný pro Váš typ stěny.

RU.

ПРИМЕЧАНИЕ! Эту мебель необходимо всегда прикреплять к стене, чтобы избежать рисков, связанных с переворотом мебели. В пакете нет крепежных винтов, потому что тип крепления должен быть выбран в соответствии с типом стены. Выберите, пожалуйста, правильные винты к вашей стене.

RO.

ATENȚIE! Mobila trebuie ancorată permanent în perete pentru a evita riscul de răsturnare a mobilei. În pachet nu sunt incluse șuruburile de fixare, deoarece tipul de ancoraj trebuie ales în funcție de tipul de perete. Alegeți șuruburile potrivite pentru tipul Dvs. de perete.

TR.

DİKKAT! Devrimle riskini önlemek için mobilya duvara sabitlenmelidir. Sabitleme civataları pakete dahil değil, çünkü sabitleme tertibatının tipi, duvara tipine uygun olarak seçilmelidir. Onu duvarınızın tipine göre seçiniz.

AR.

ملاحظة!

يجب تثبيت الأثاث بإحكام إلى الحائط أو الجدار لتجنب خطر إنقلابه. لا تحتوي العلبة على مسامير التثبيت، إذ إنه ينبغي إستعمال المسامير المخصصة لنوعية الحائط أو الجدار. اختر المسامير التي تناسب جدارك.

E.

¡ATENCIÓN! El mueble debe ser fijado permanentemente a la pared para evitar el riesgo relacionado con el vuelco del mueble. En el paquete no hay tornillos de fijación, ya que se debe elegir el tipo de fijación adecuado para el tipo de pared. Elija el apropiado para su tipo de pared.

CN.

注意！本家具需要固定在墙上以免倒塌。箱子里没有安装螺钉。因为安装方式需要根据墙的类型调整。请按照您的墙类型选择合适的安装方式。

SLO.

POZOR! Pohištvu trajno pritrđite na steno, da preprečite tveganje, da se prevrne. V paketu ni pritrđilnih vijakov, saj je treba način pritrđitve ustrezno izbrati glede na vrsto stene. Izberite način, ki je ustrezen za vašo steno.

HU.

FIGYELEM! Rögzítse a bútorokat a falhoz, hogy elkerülje a bútor felborulásának kockázatát. A készletben nem találhatóék rögzítőcsavarok, mivel a rögzítés típusa a fal típusától függ. Válassza ki a fal típusának megfelelő kötőelemeket.

NL.

OPMERKING! De meubelen moeten permanent aan de muur worden bevestigd om te voorkomen dat de meubelen kantelen. Er zitten geen bevestigingsschroeven in het pakket, omdat het type bevestiging moet worden gekozen op basis van het type muur. Kies de juiste voor uw type muur.

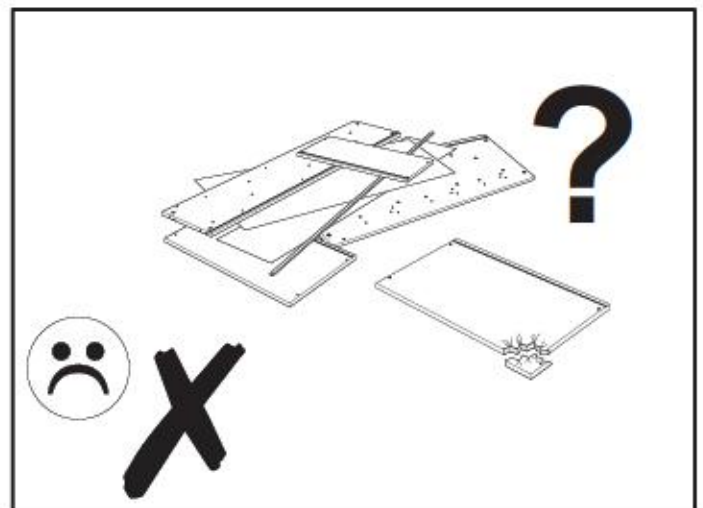
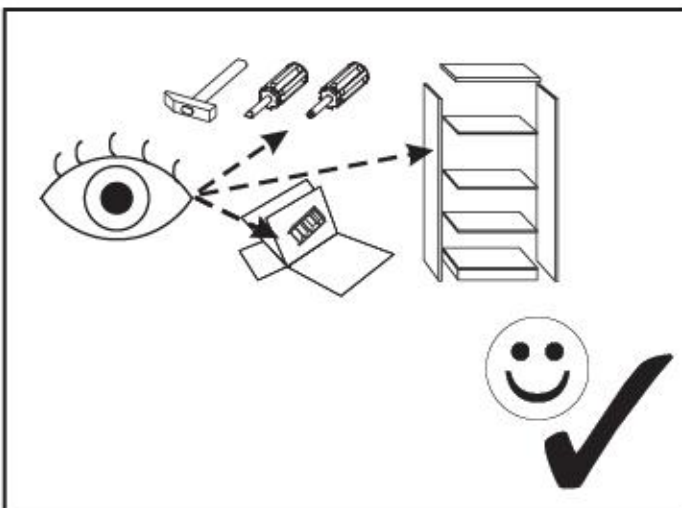
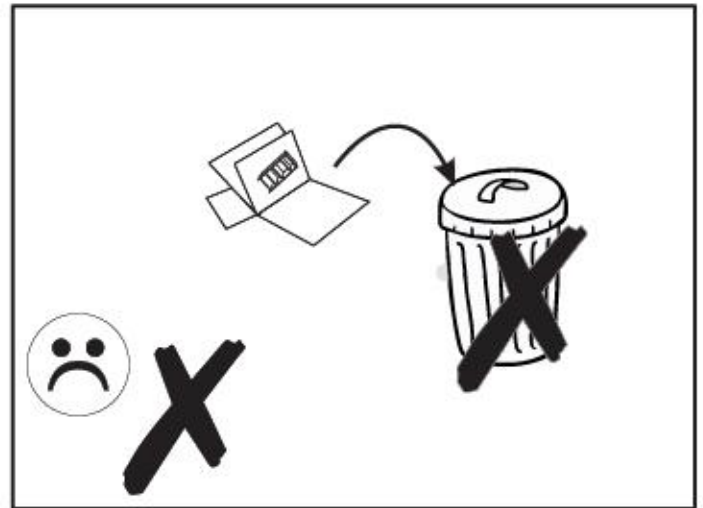
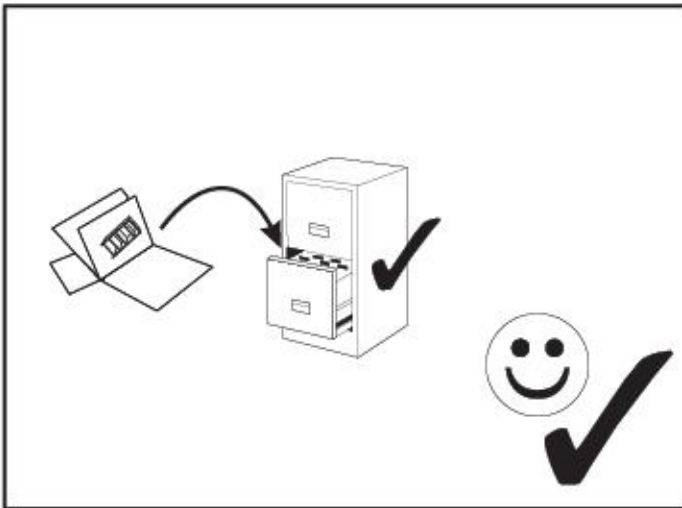
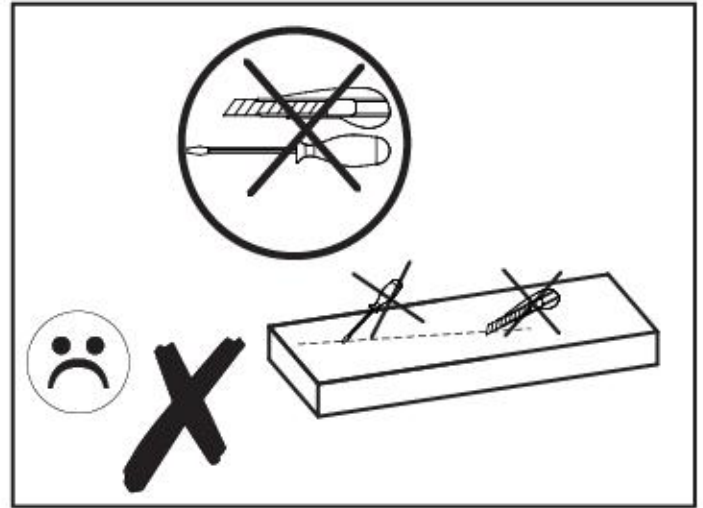
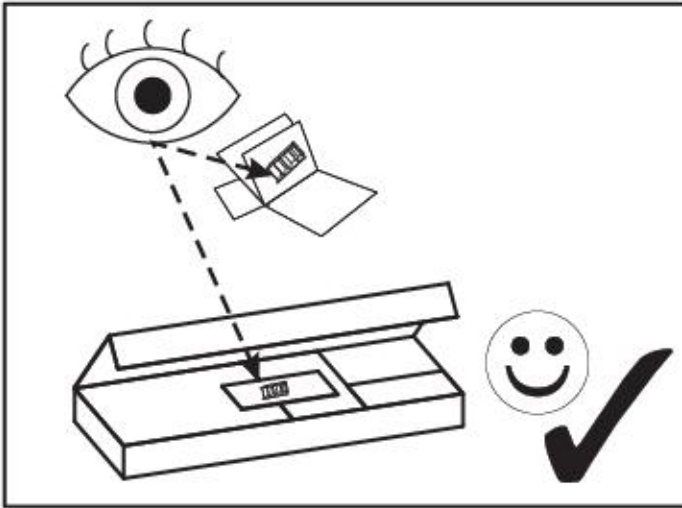

1YYASC45/1PPASC45

MM

260

250

240

230

220

210

200

190

180

170

160

150

140

130

120

110

100

90

80

70

60

50























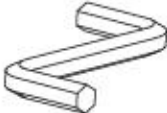

40

30

20

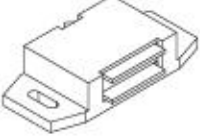
10

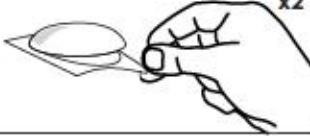
0

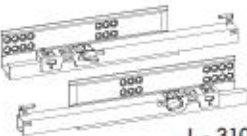
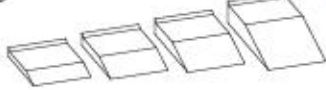
A0 8 x 20 mm x12 	A1 8 x 35 mm x64 	C2 5 x 13 mm x12 
D2  x4	E0 Ø16 x8 	E1 15 x 12 mm x38 
F1 6 x 34 mm x38 	G1 7 x 50 mm x12 	H1 L - 131mm x3 
H2 L - 78mm x1 	I0 3 x 13 mm x2 	I2 4 x 16 mm x2 
K3 M4 x 22mm x8 	M x1 	M1 x1 
N1 3 x 16 mm x15 	N14 4 x 30 mm x12 	O2 x8 
OB1 L - 516 mm x1 	OB2 L - 1110 mm x1 	P16 x4 
Q1 x1 	Q9 x2 	R4 x3 
R8 x2 	R10 x1 	S17 x4 
T10 L - 310 mm x3 	Z x1 	



1YYASC45/1PPASC45

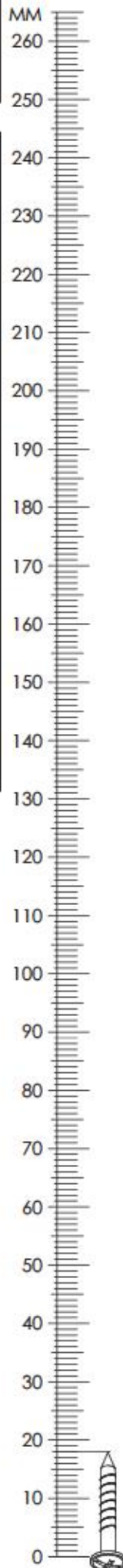

BE SC 07 48 00

x1



x1



x3



x3

RL1



x4

RL3



x2

RL2



x2

RL5



x2

RL6



x2

RL7



x1

1YYASC45/1PPASC45

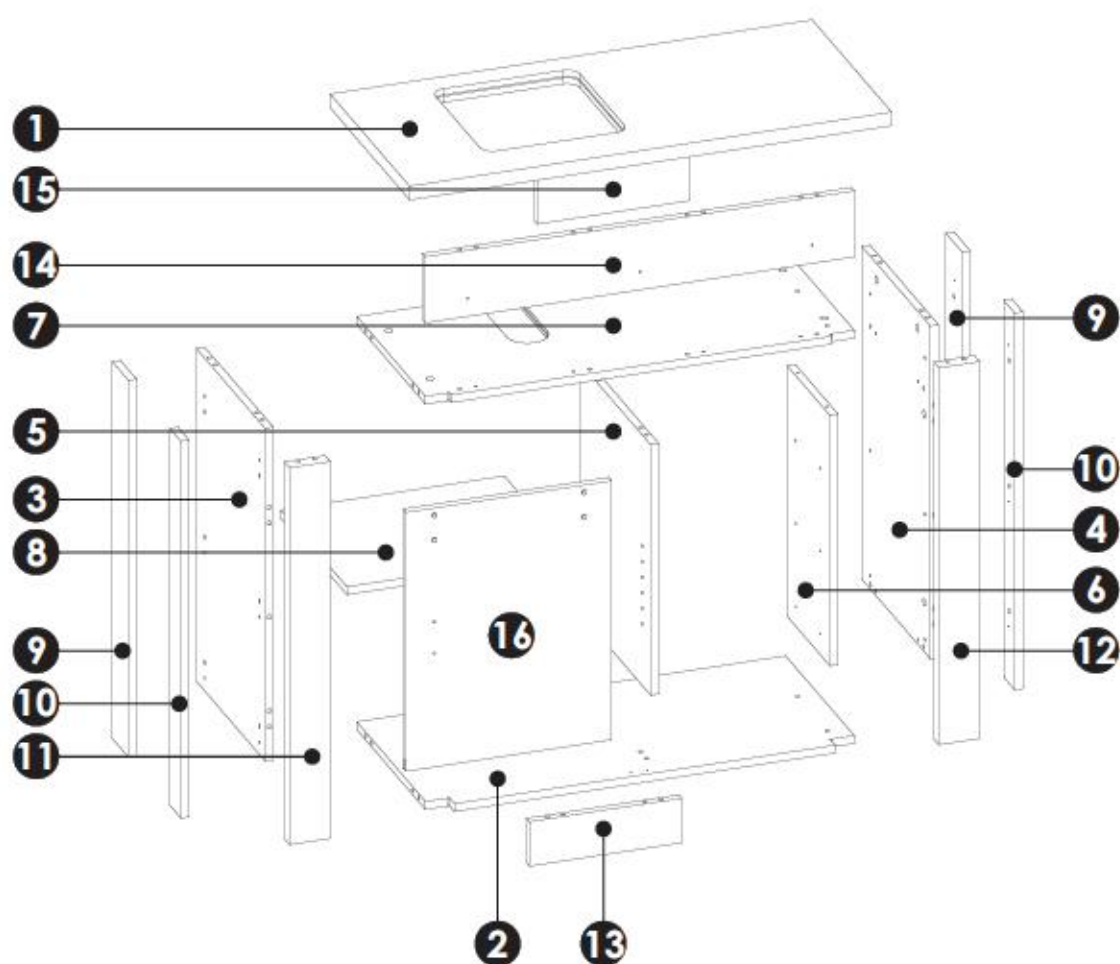
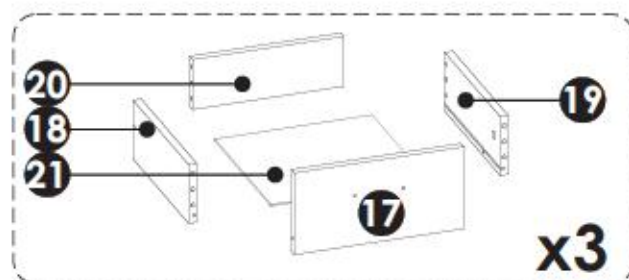

1	950	430	28	x1	1/2
2	845	399	16	x1	2/2
3	680	372	16	x1	1/2
4	680	372	16	x1	1/2
5	512	379	16	x1	1/2
6	512	231	16	x1	2/2
7	845	380	16	x1	2/2

8	440	357	16	x1	1/2
9	770	88	16	x2	2/2
10	770	60	16	x2	2/2
11	770	80	28	x1	2/2
12	770	80	28	x1	2/2
13	300	91	16	x1	2/2
14	845	135	16	x1	2/2

15	300	135	16	x1	2/2
16	529	405	16	x1	1/2
17	334	167	16	x3	1/2
18	300	120	16	x3	2/2
19	300	120	16	x3	2/2
20	298	102	16	x3	2/2
21	310	305	3	x3	1/2

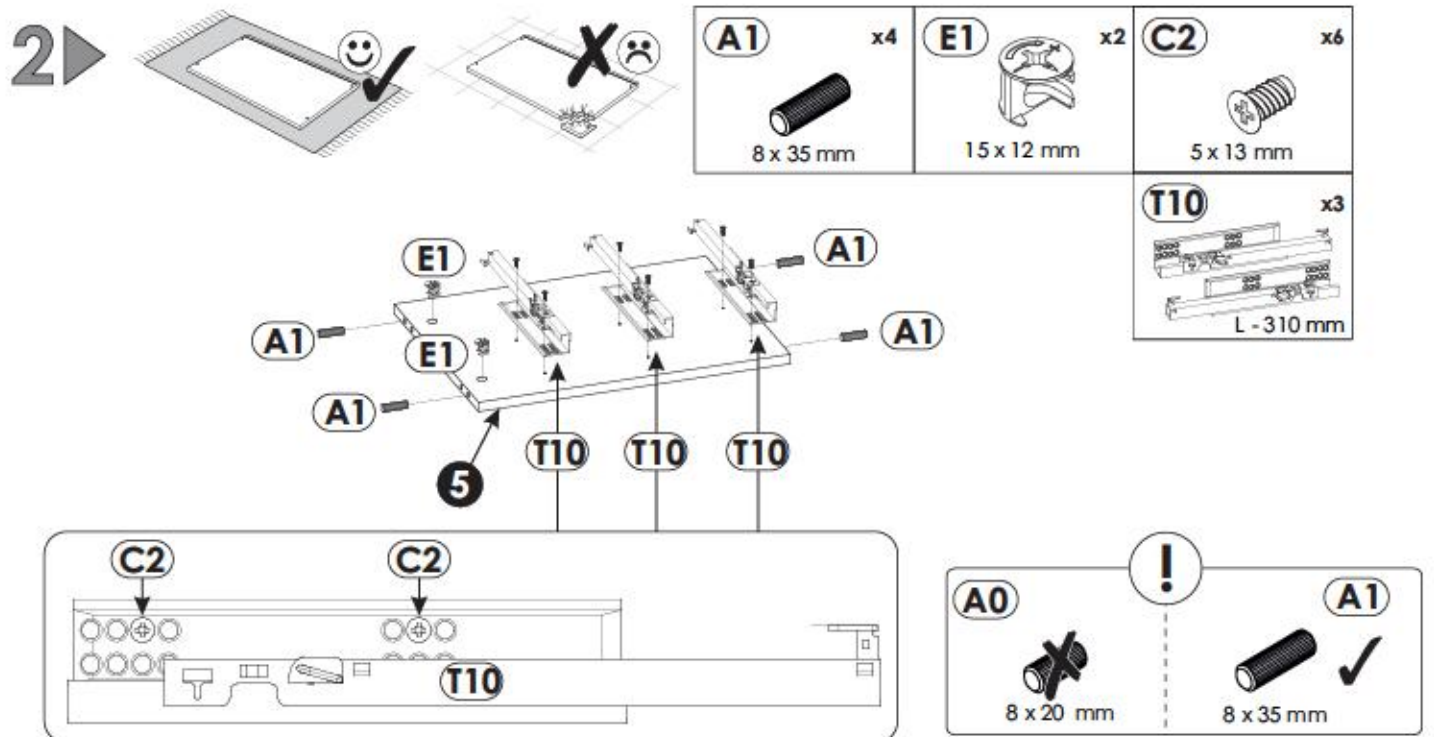
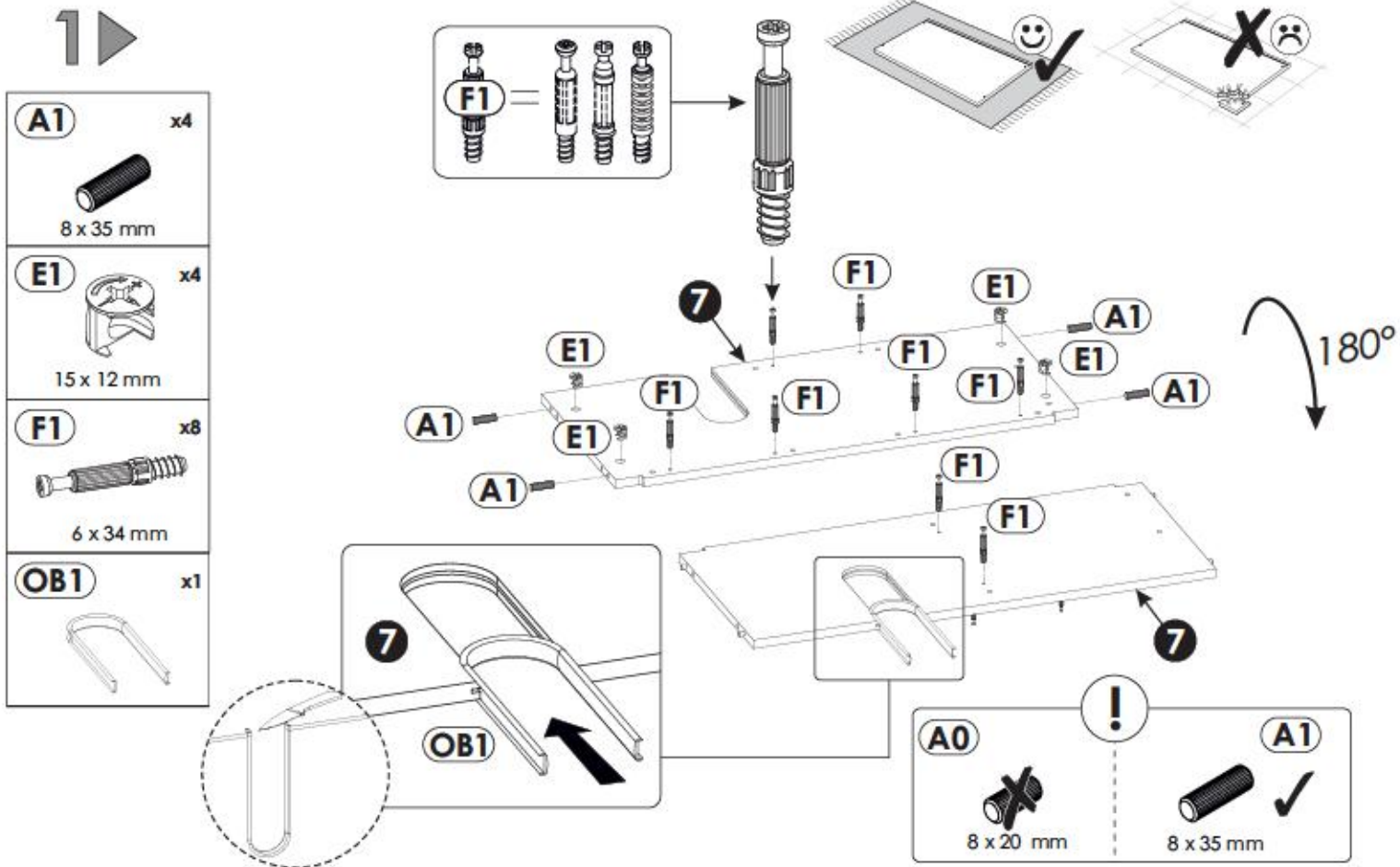
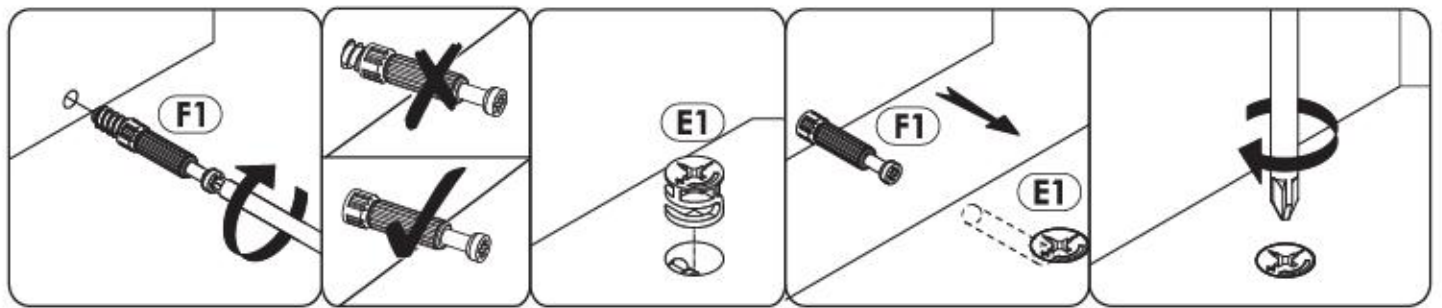

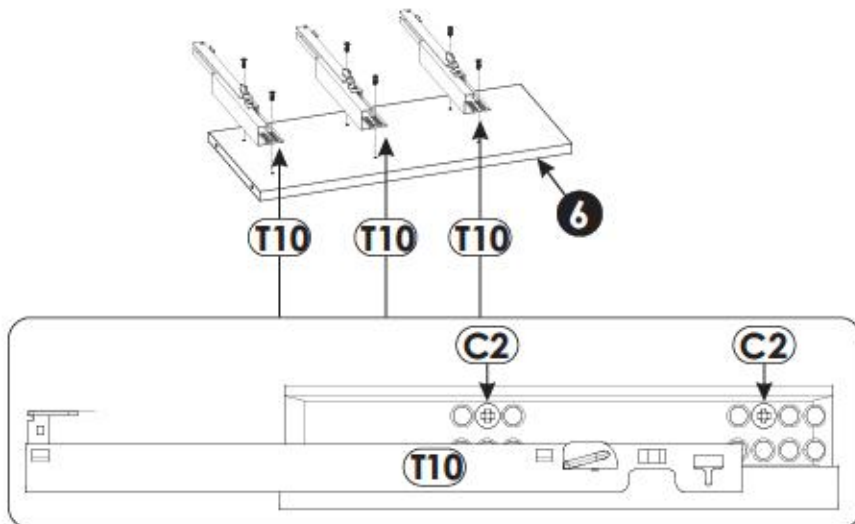
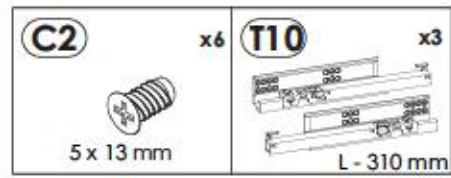
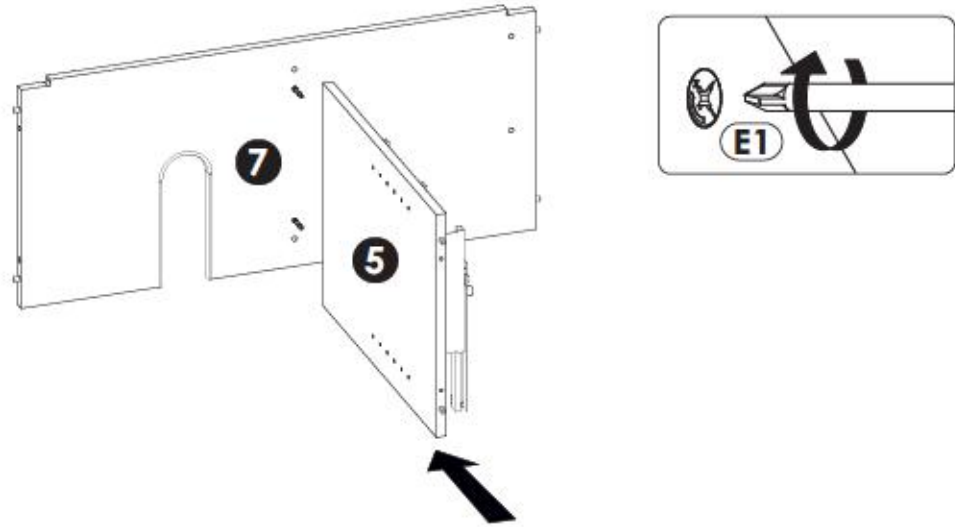

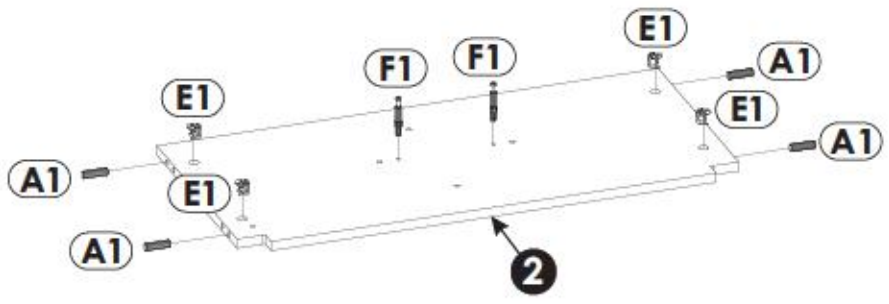
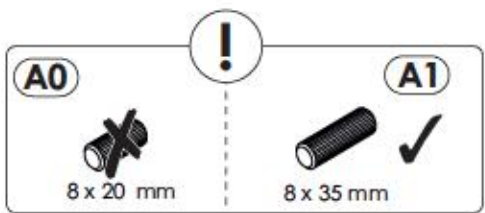
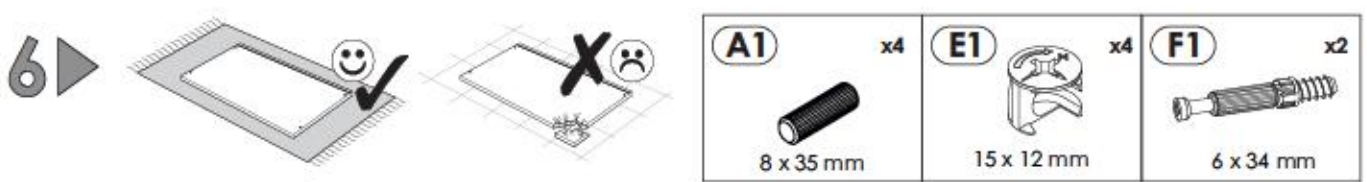
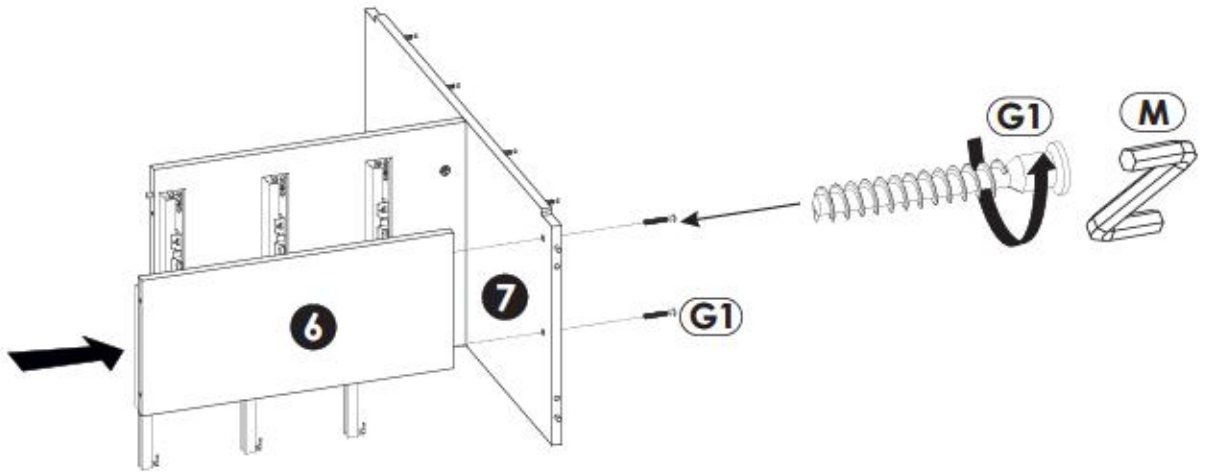
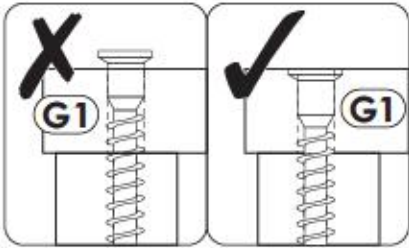
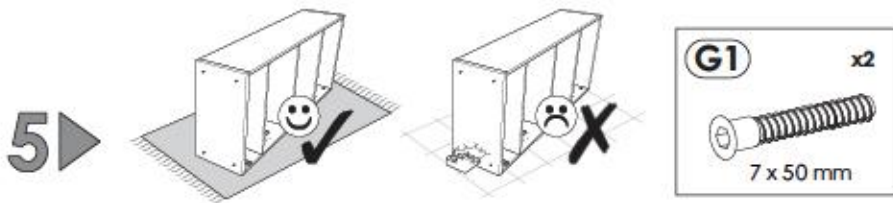

7 ▶

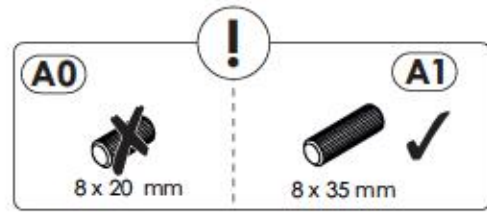
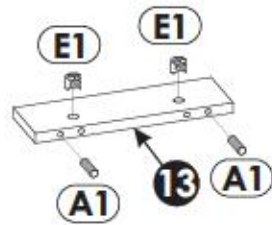
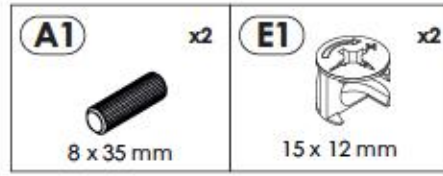

8 ▶

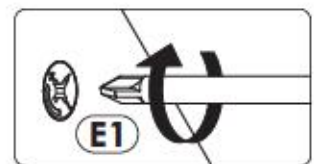
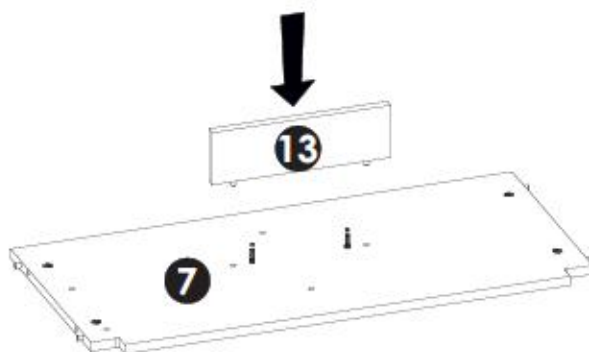
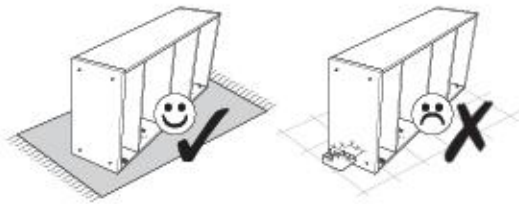

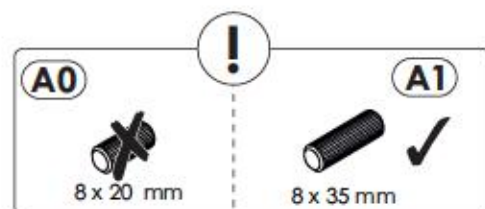
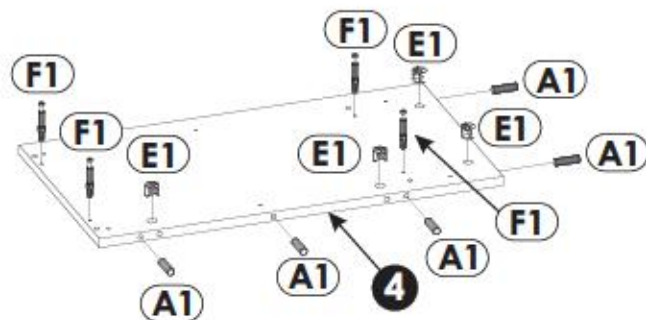
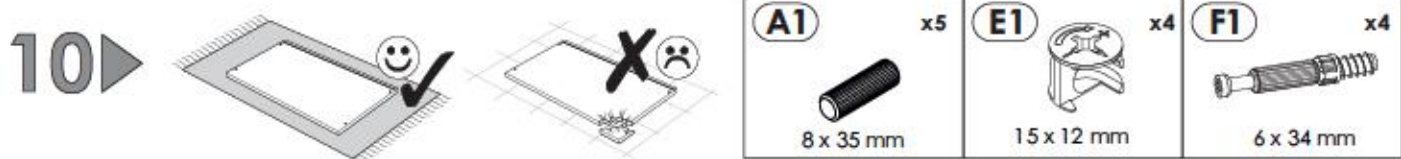
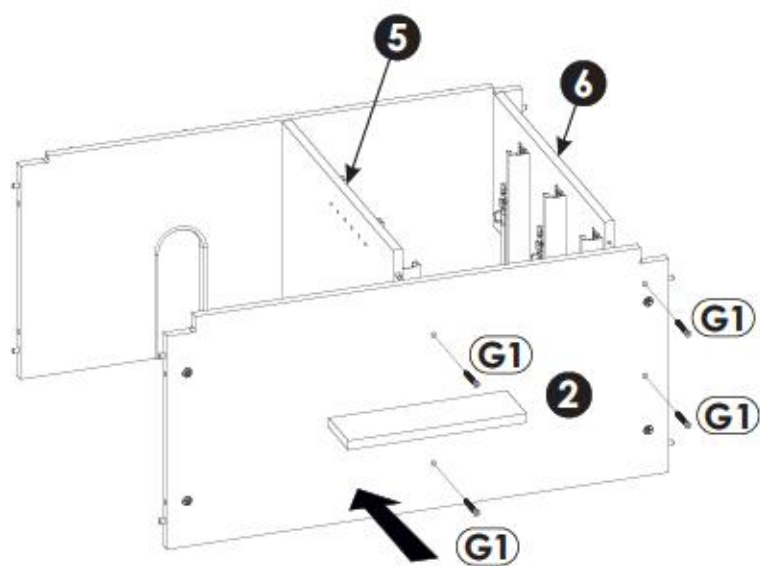
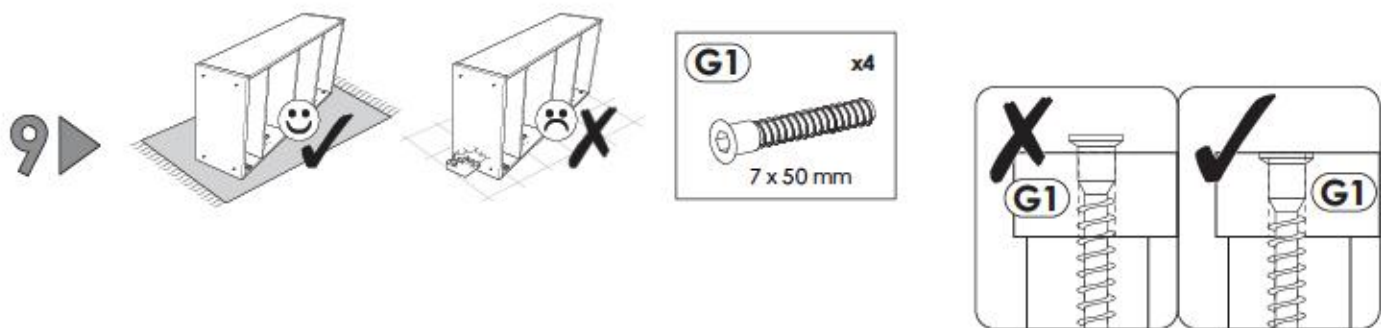

11▶

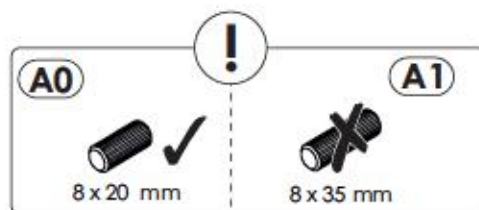
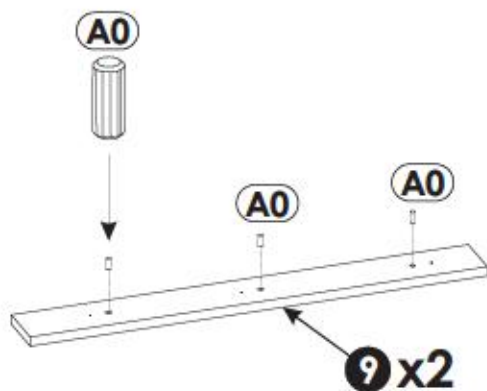
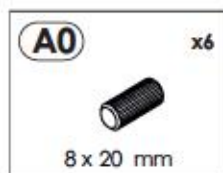
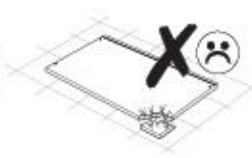
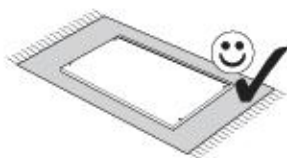

12▶

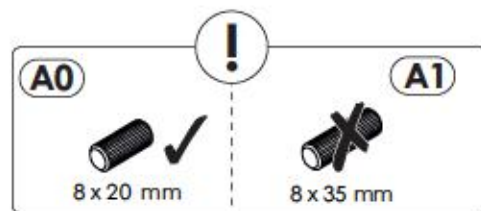
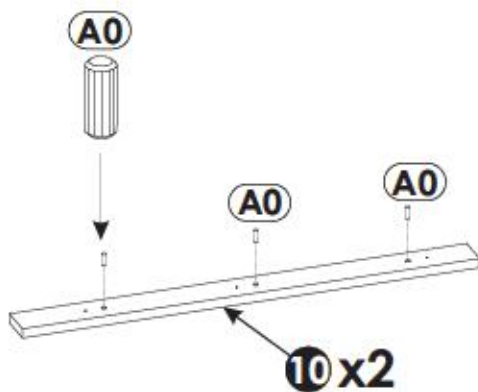
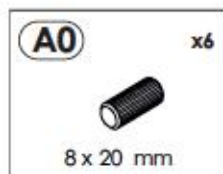
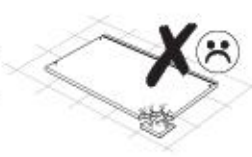
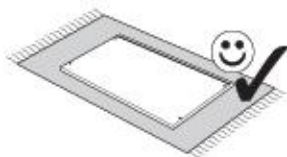

13▶

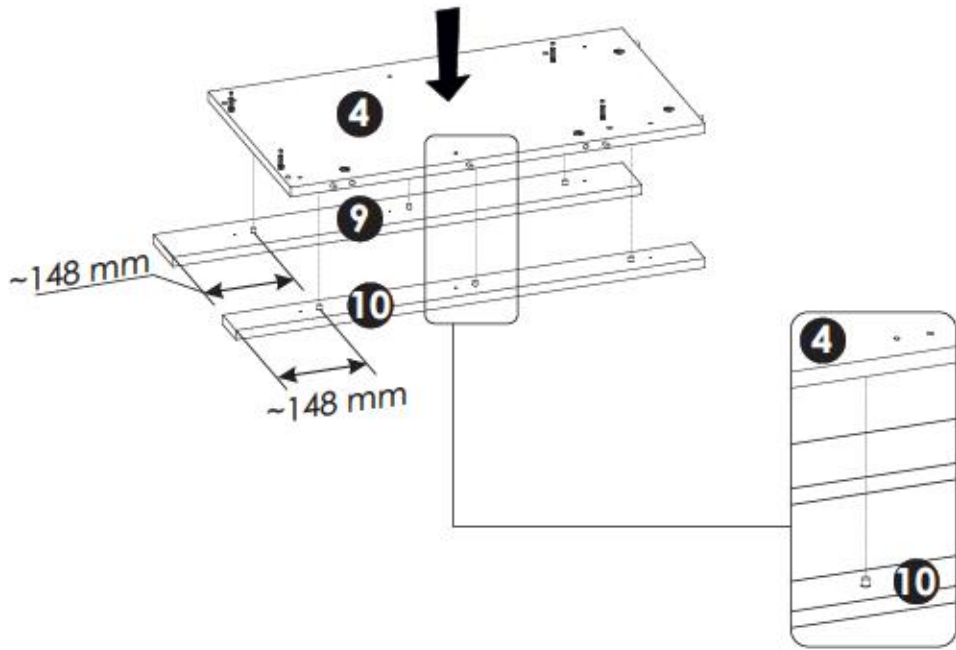

14▶

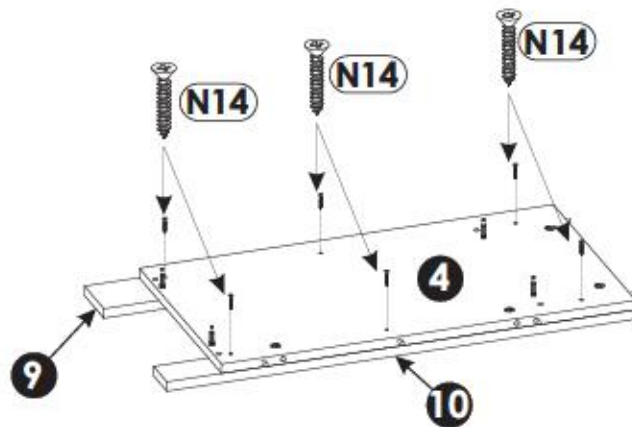
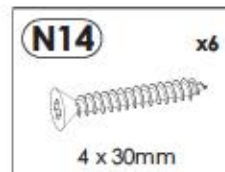
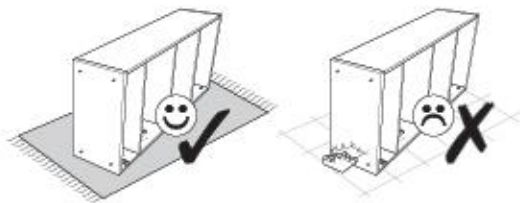

15▶

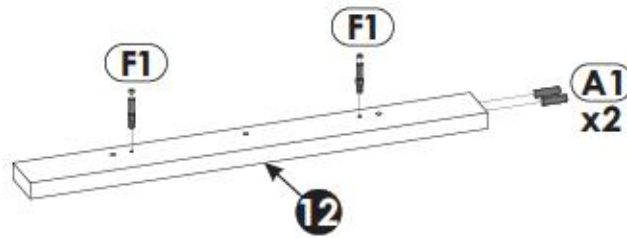
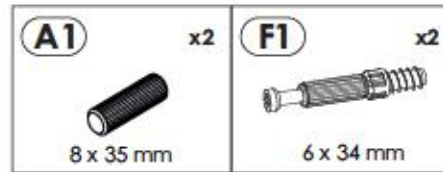

16▶

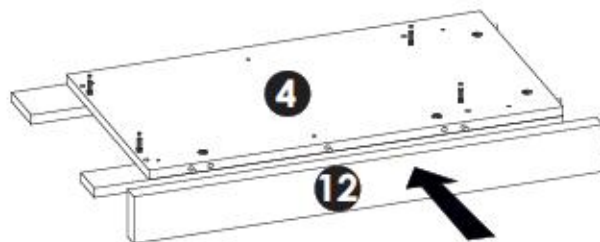
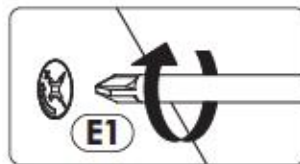
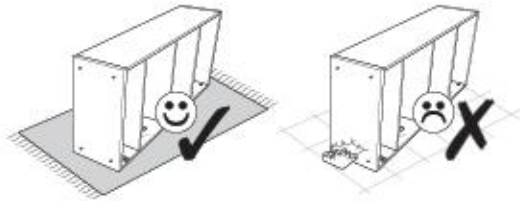

17▶

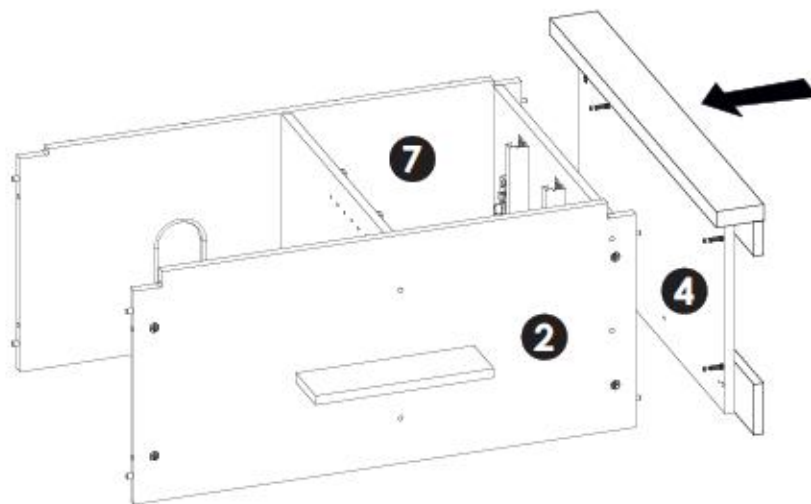
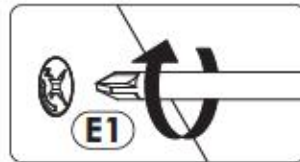
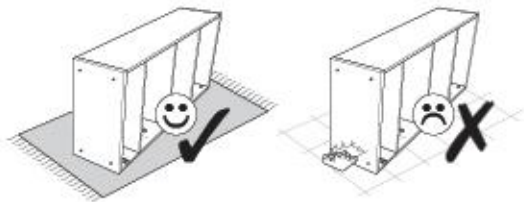

18▶

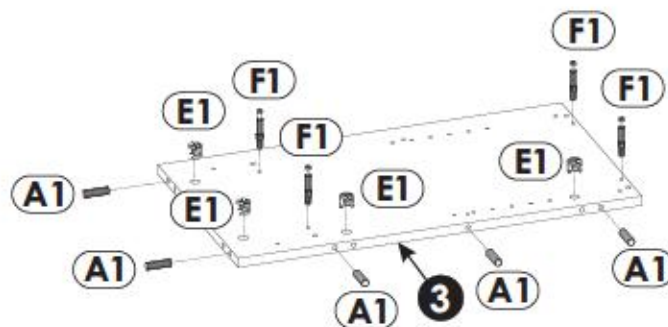
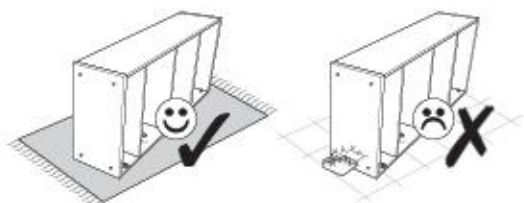

19 ▶

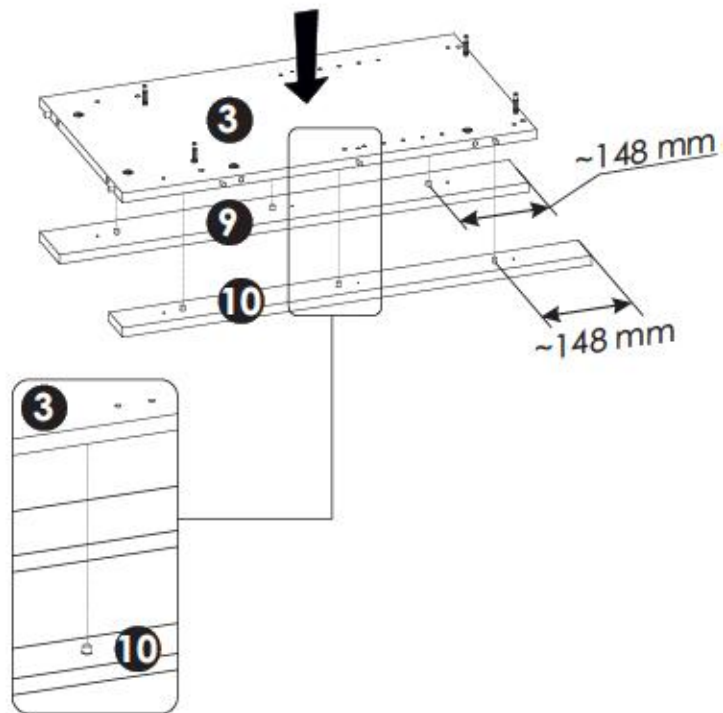
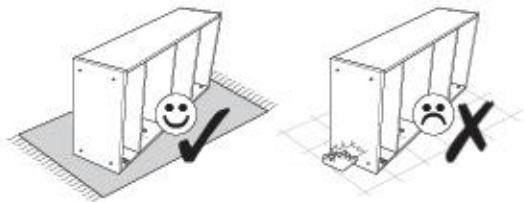

20 ▶

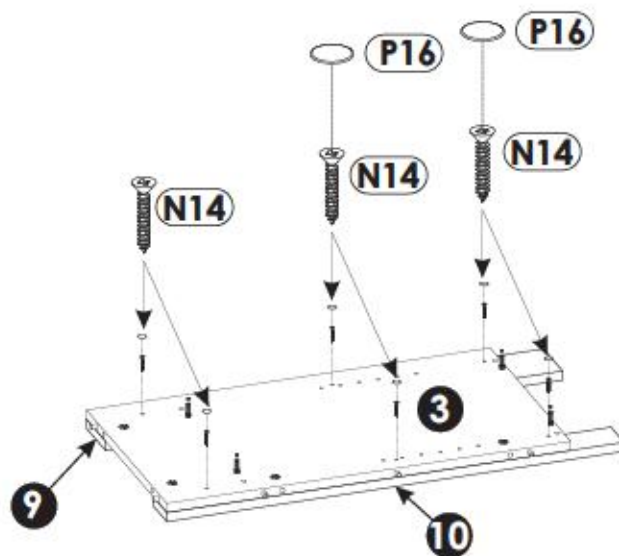
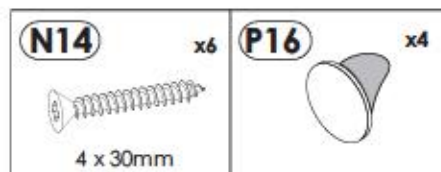
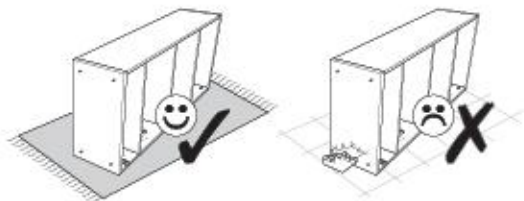

21▶

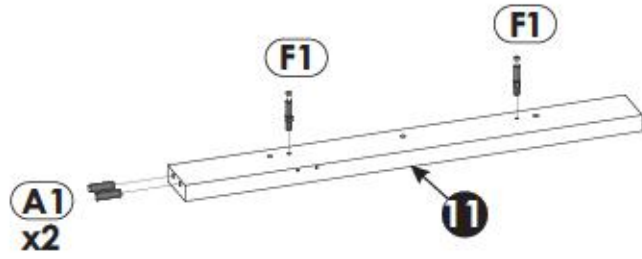
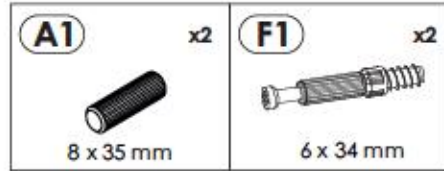

22▶

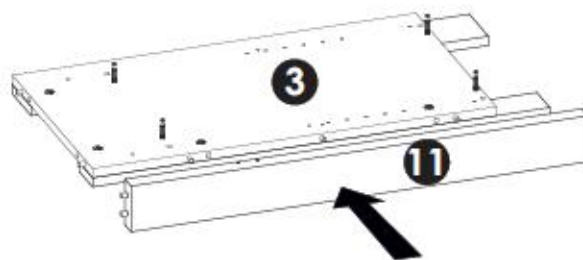
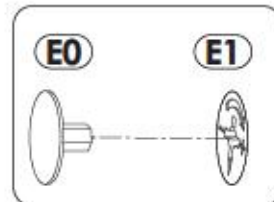
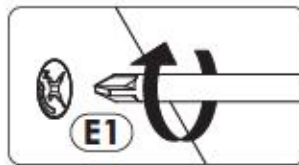
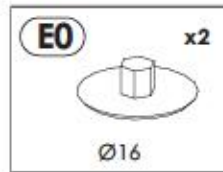
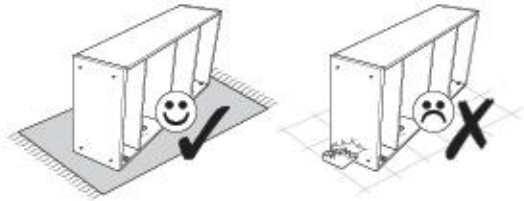

23 ▶

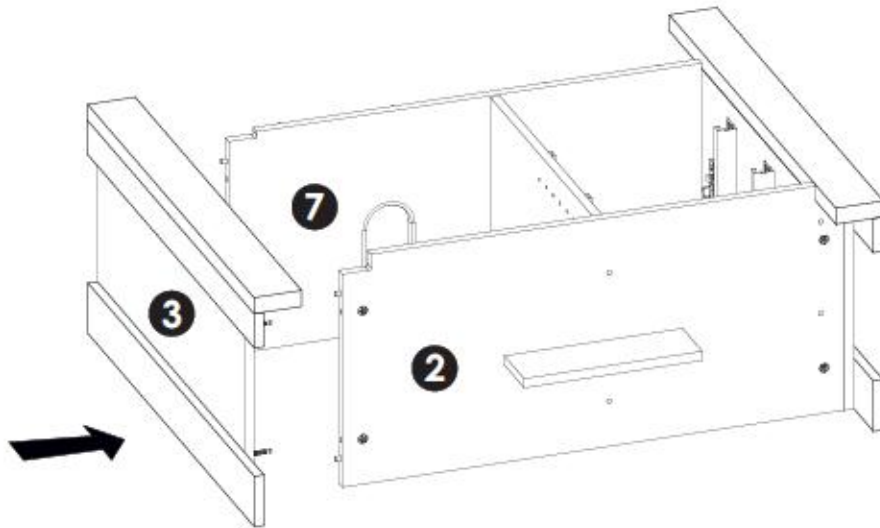
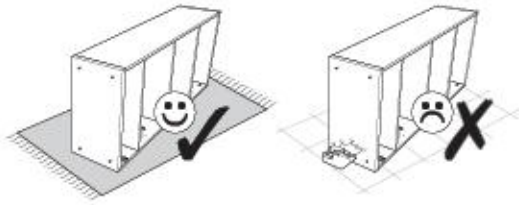

24 ▶

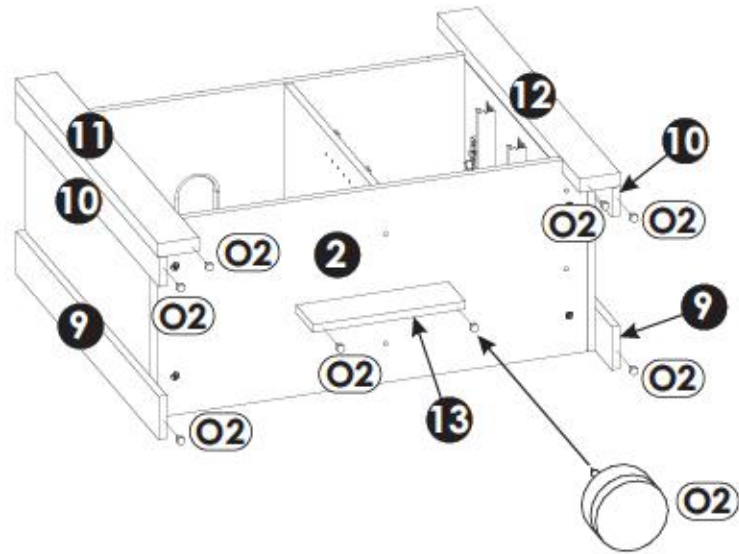
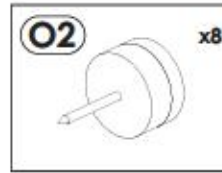

25 ▶

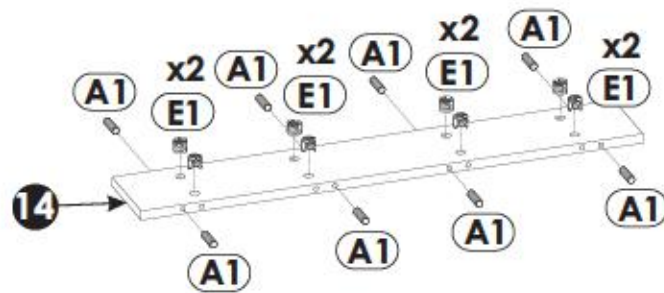

26▶

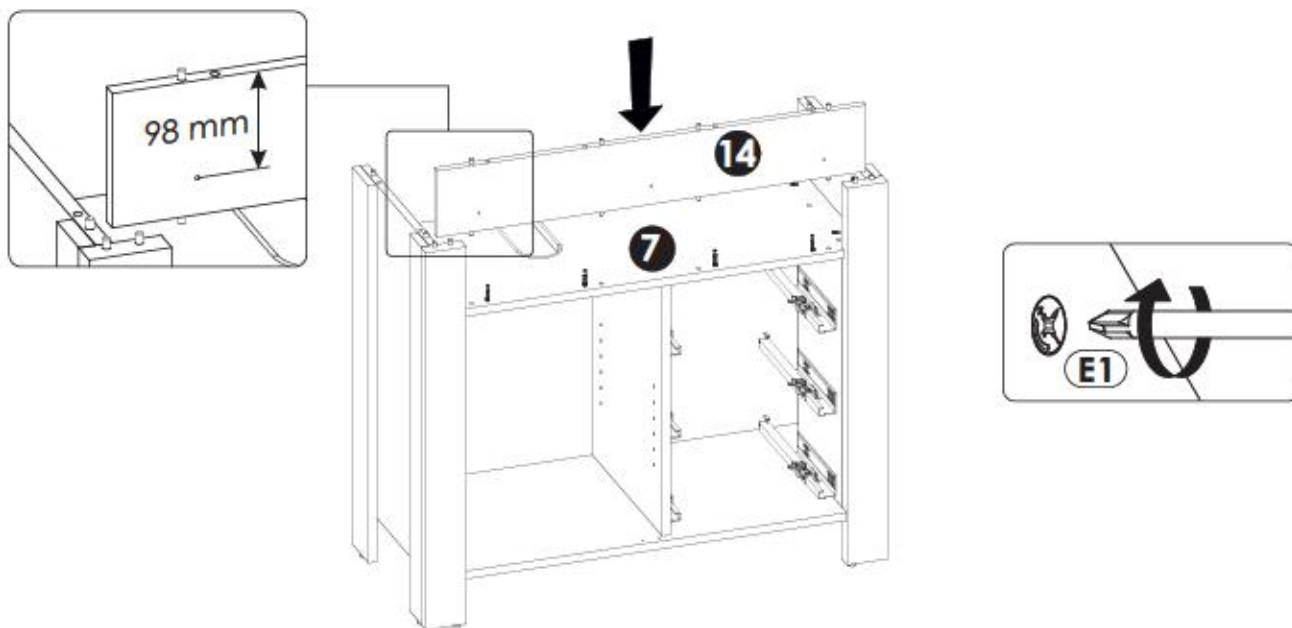

27▶

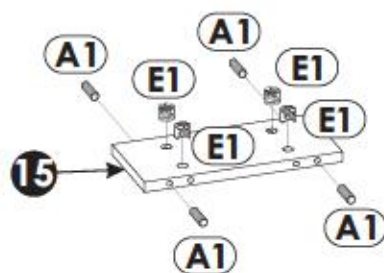

28▶

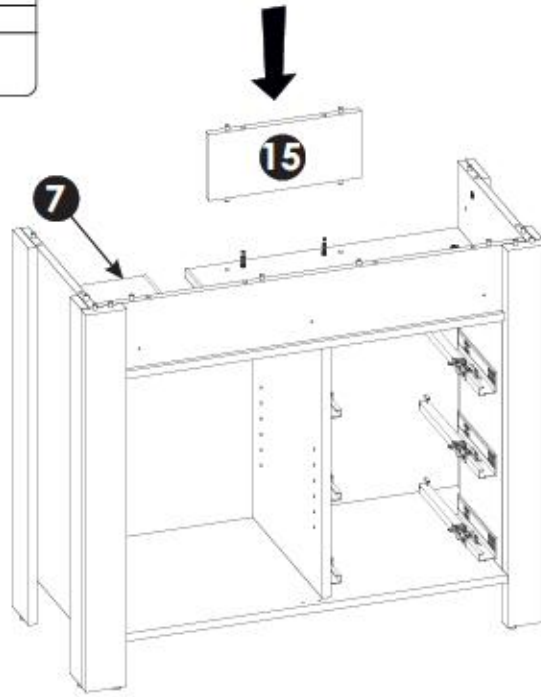

29▶

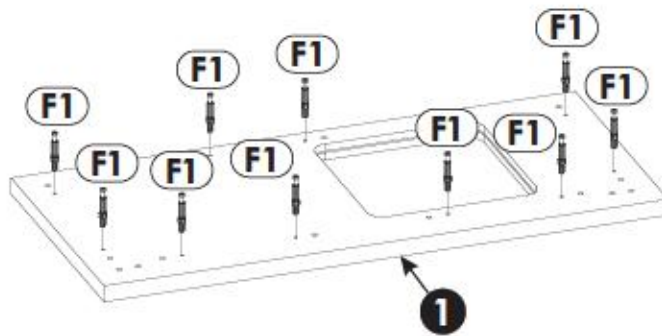
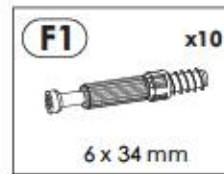
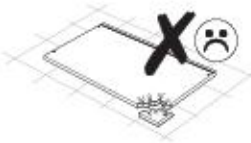
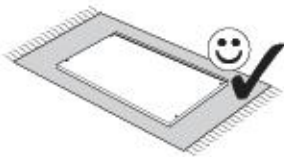

30 ▶

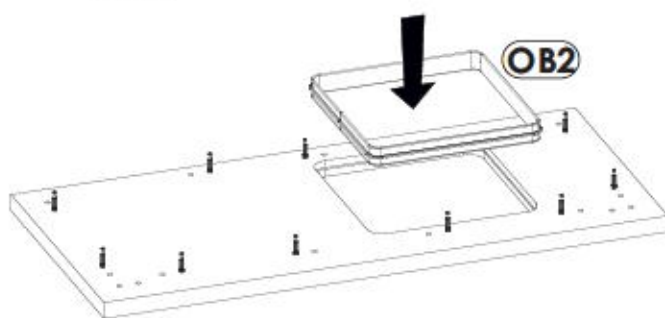
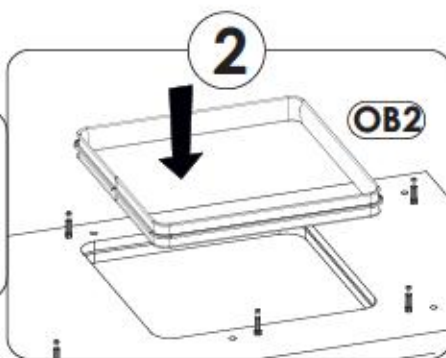
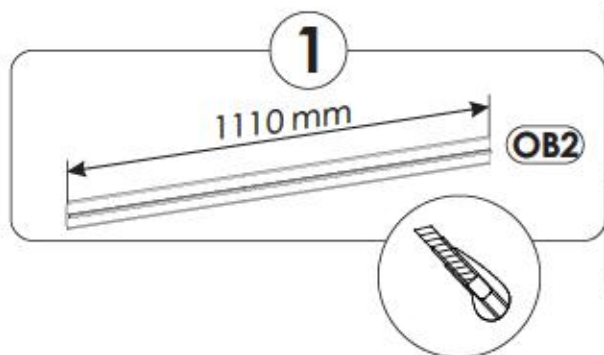
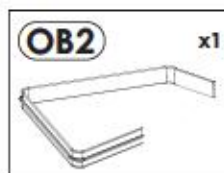
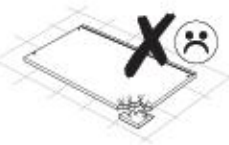
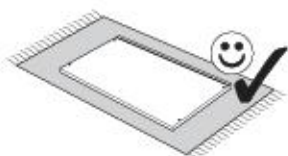

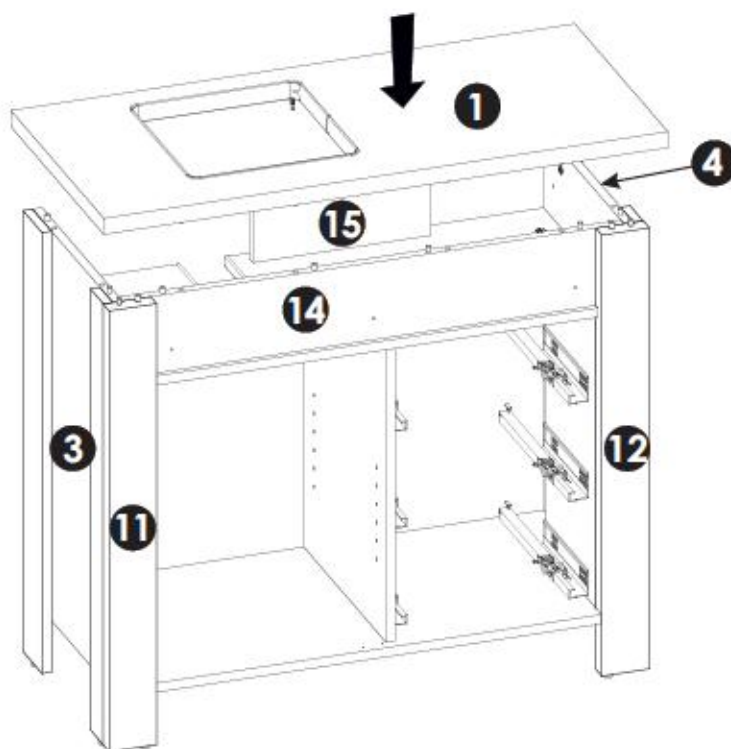

31 ▶

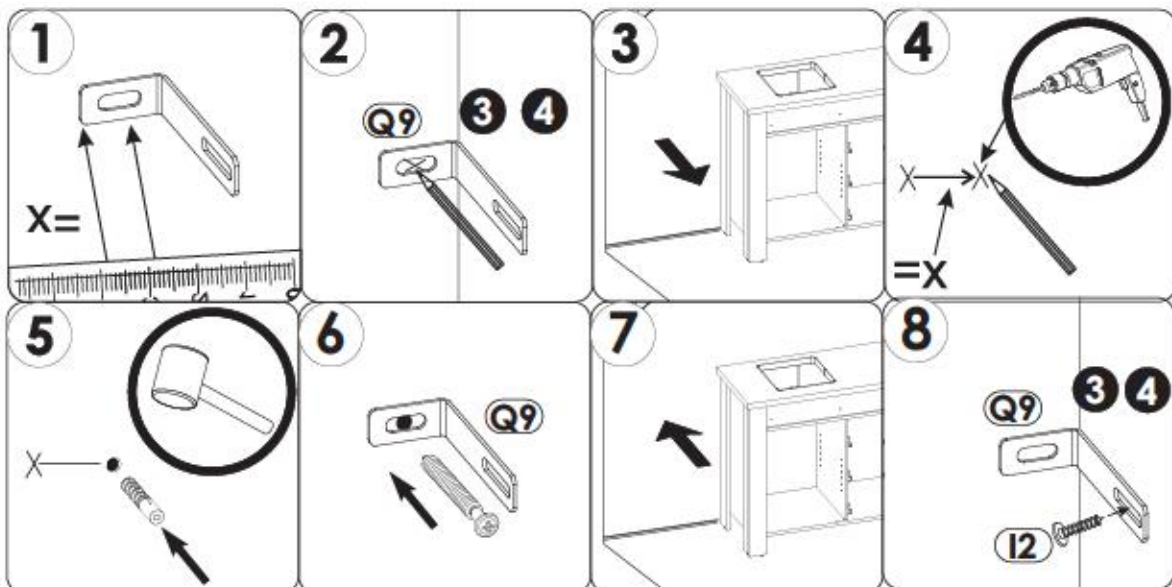
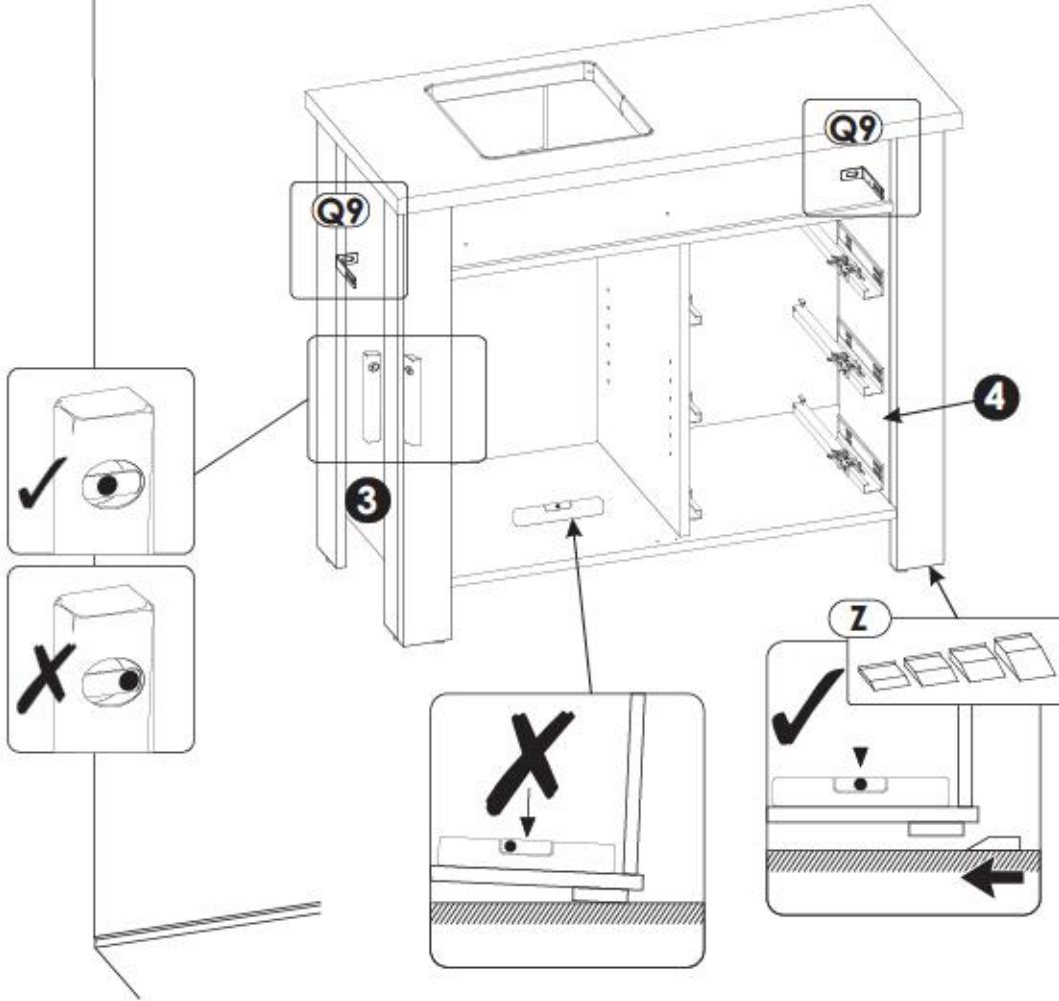
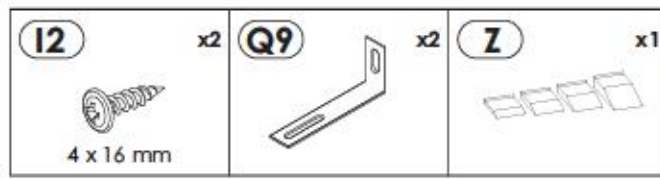

32 ▶



33▶

RL748  BE SC 07 48 00	x1	RL8 	x3	RL4 	x3
---	----	--	----	---	----

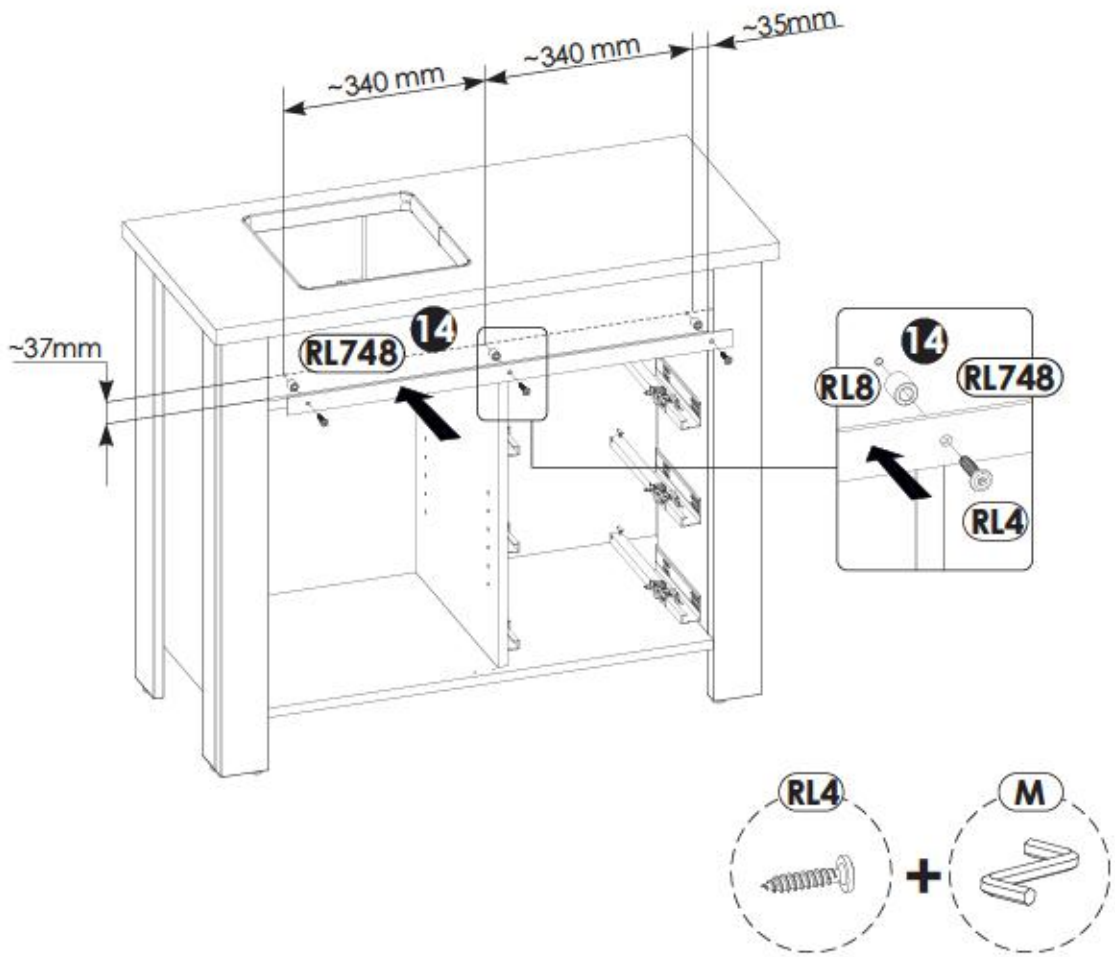

34▶

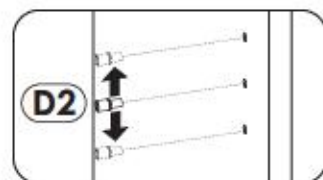
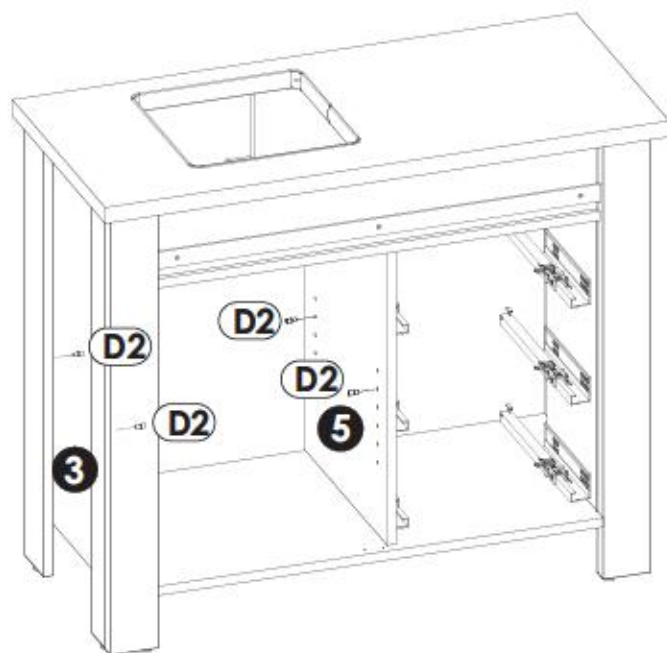
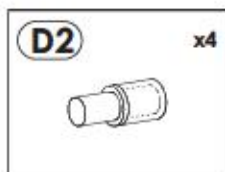

35▶

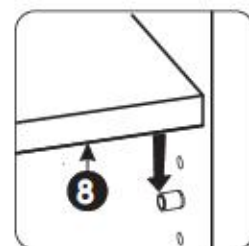
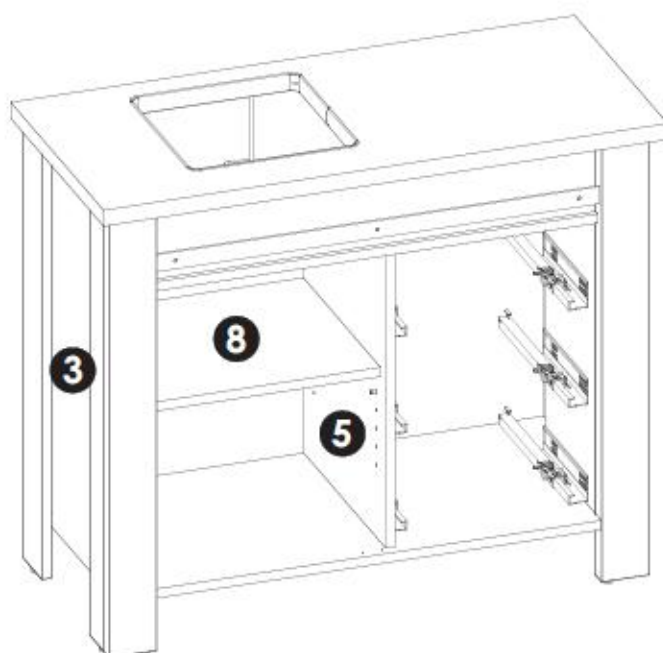

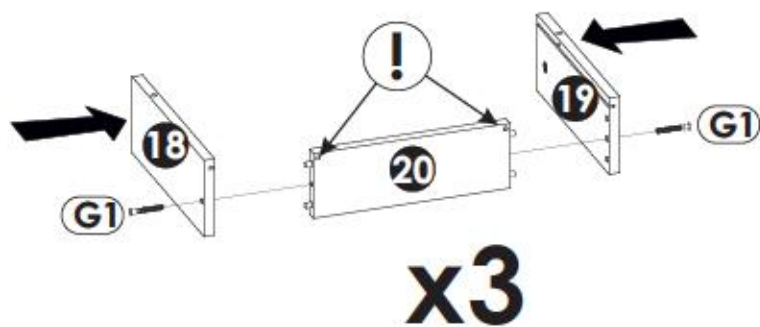
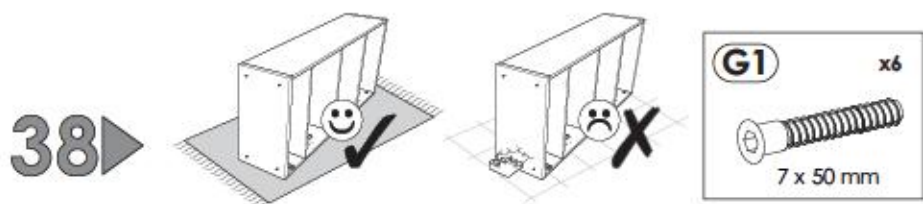
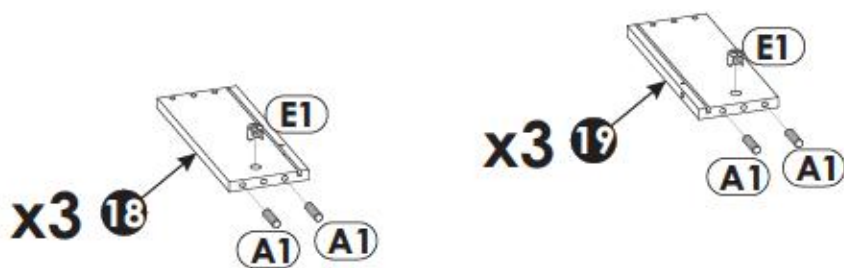
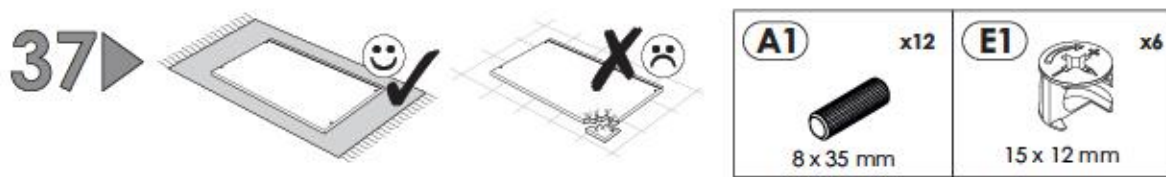
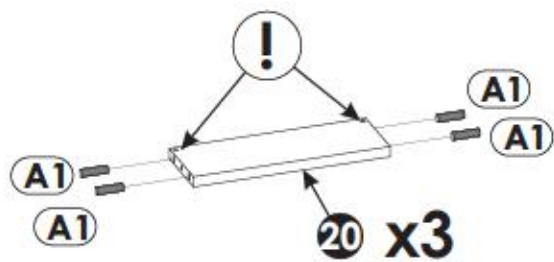

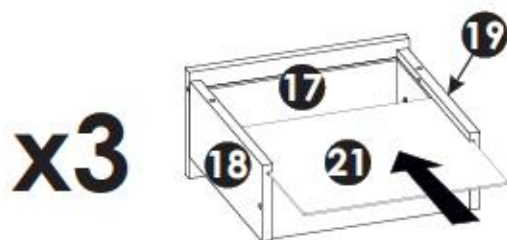
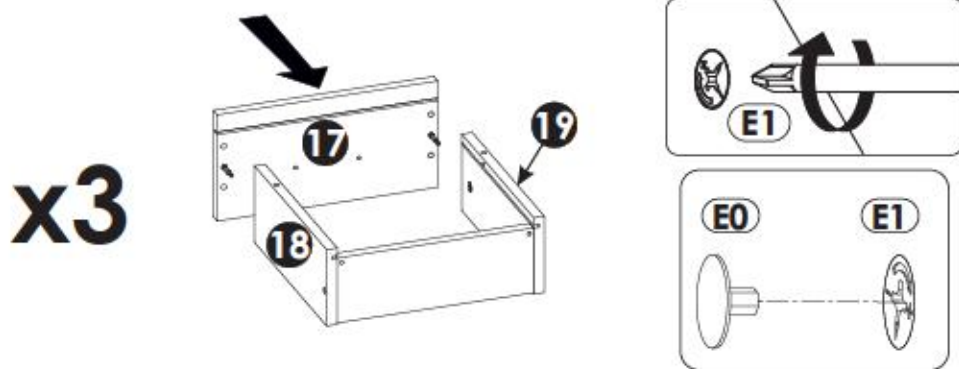
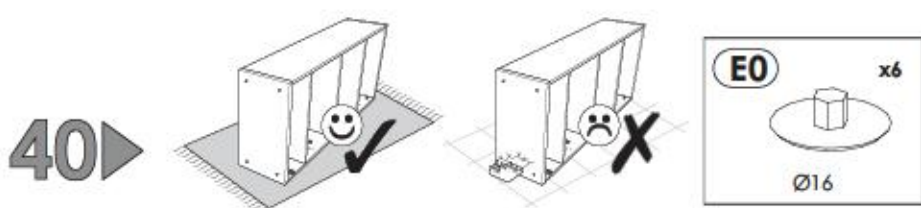
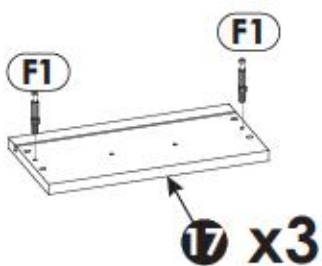

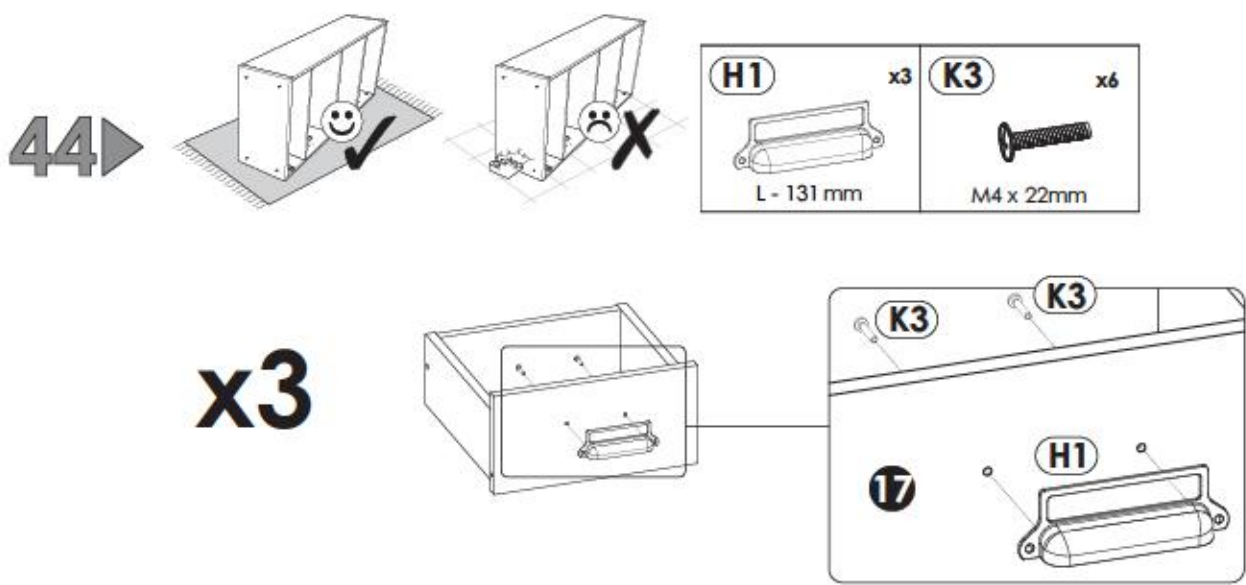
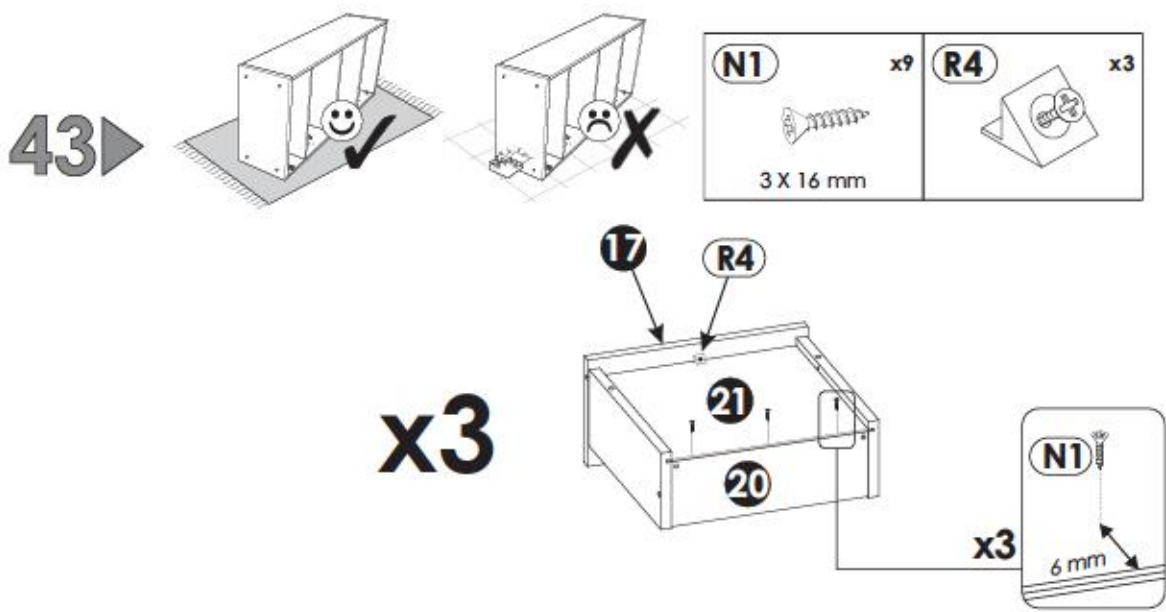
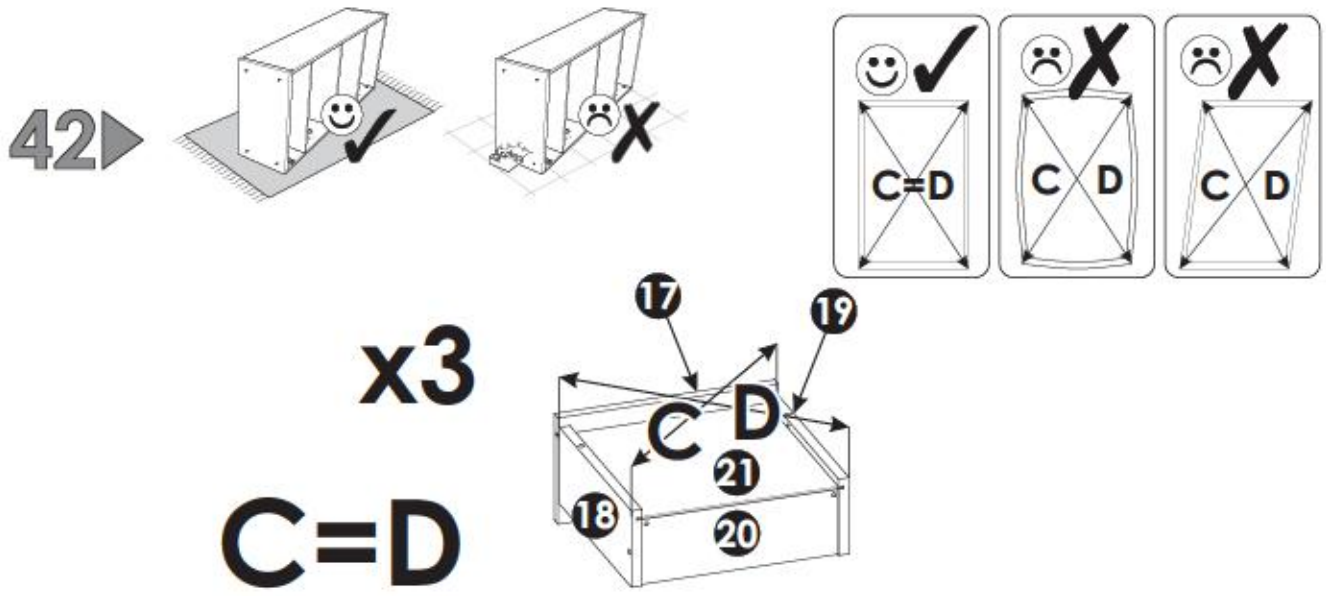

45▶

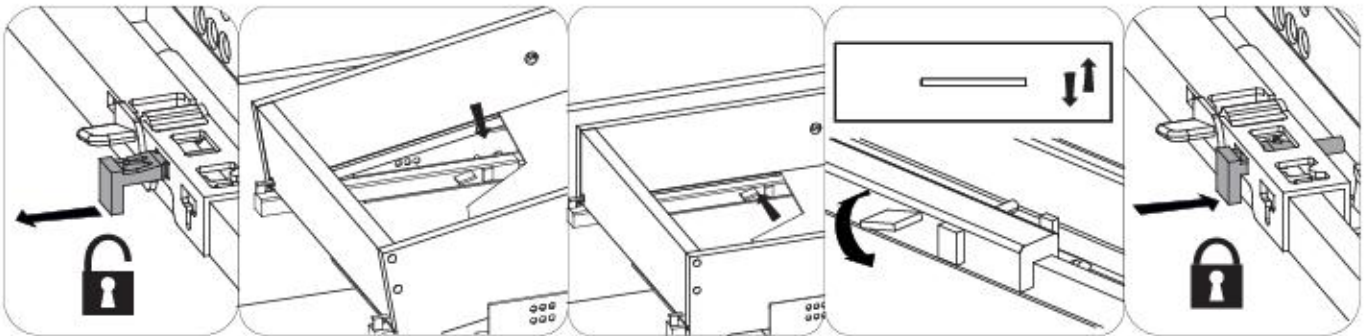
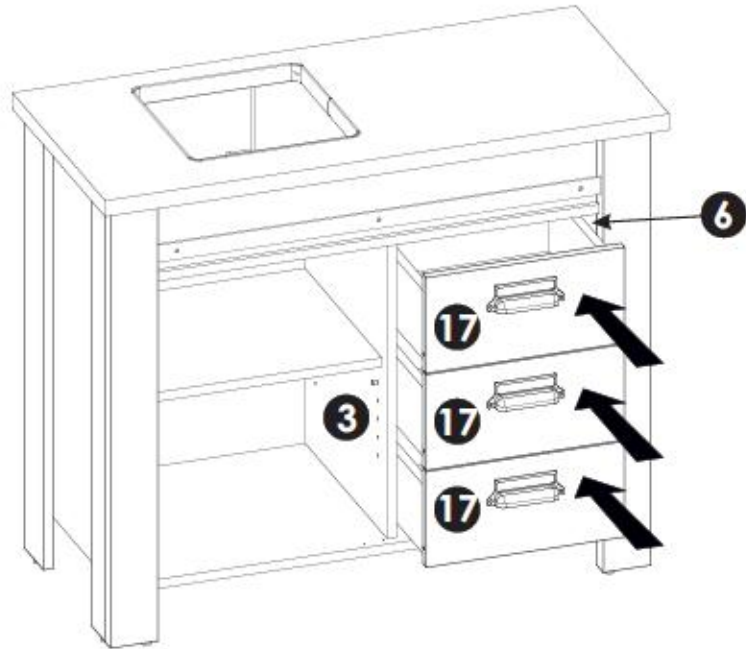

46▶

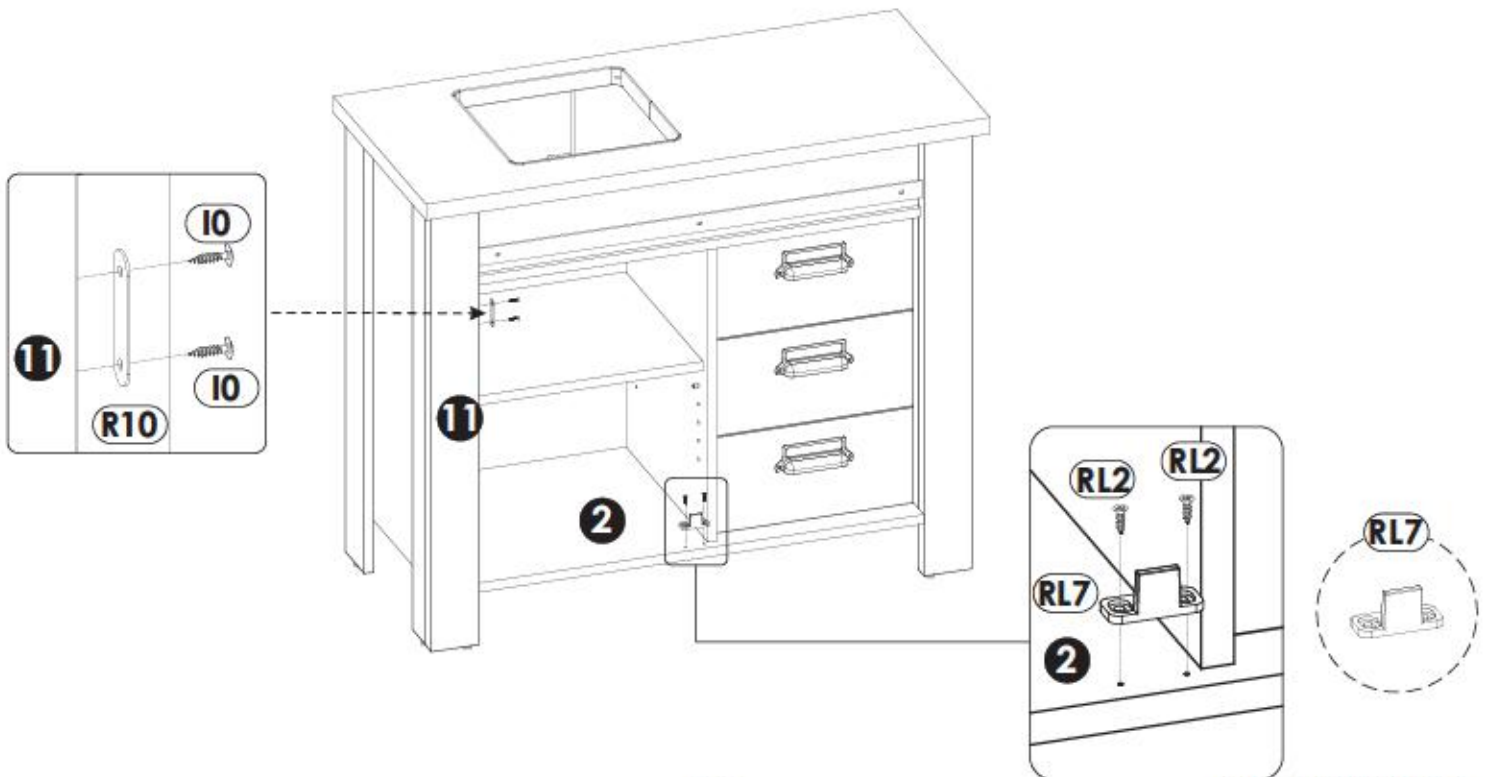
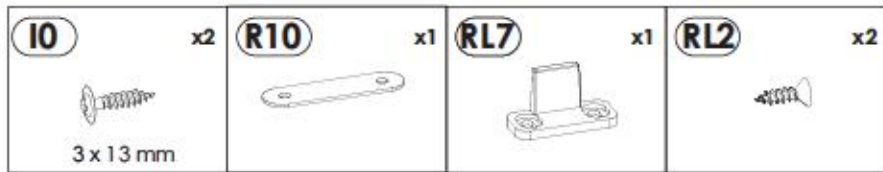

47▶

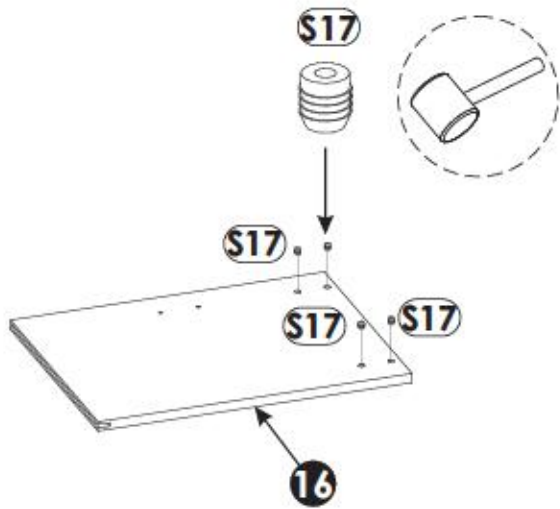
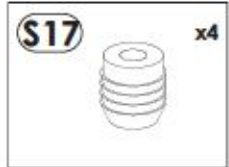

48▶

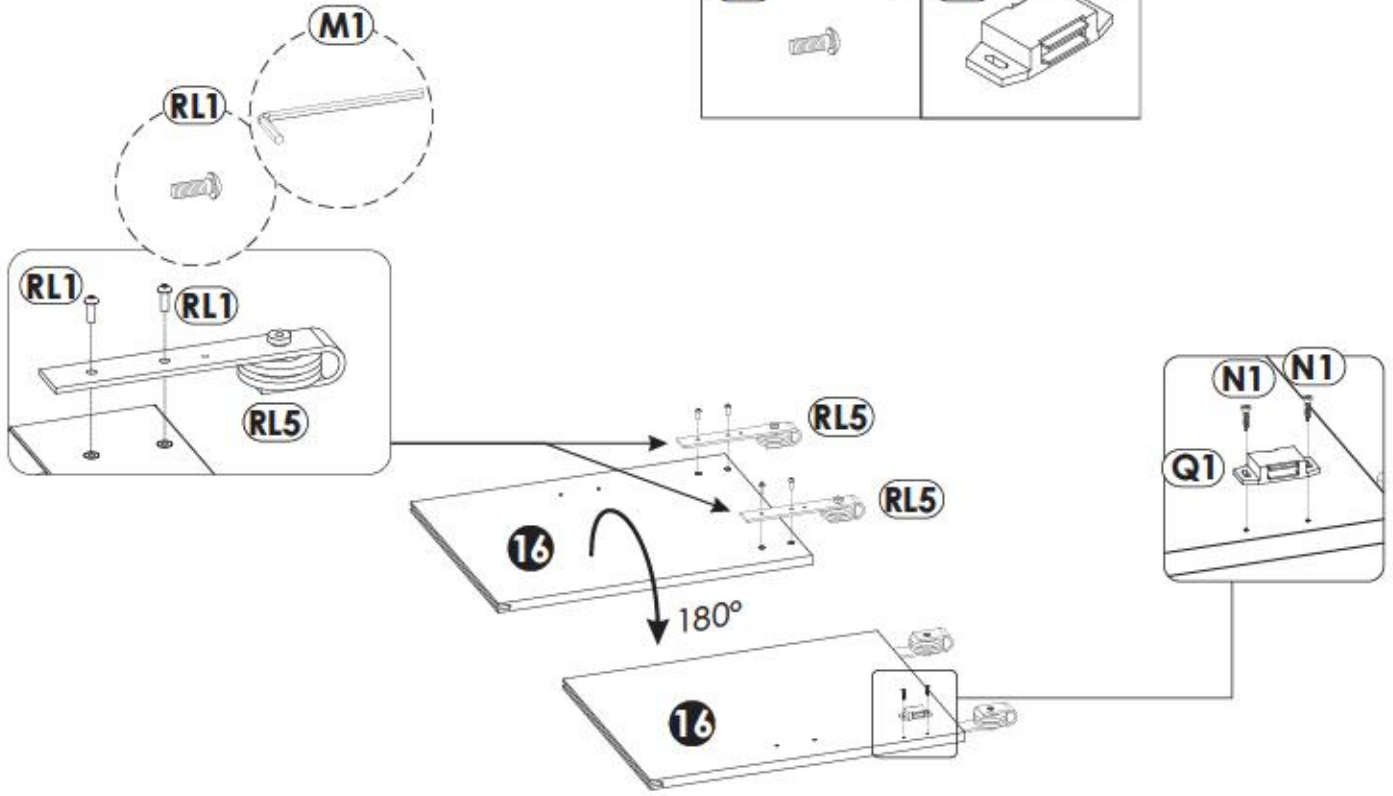
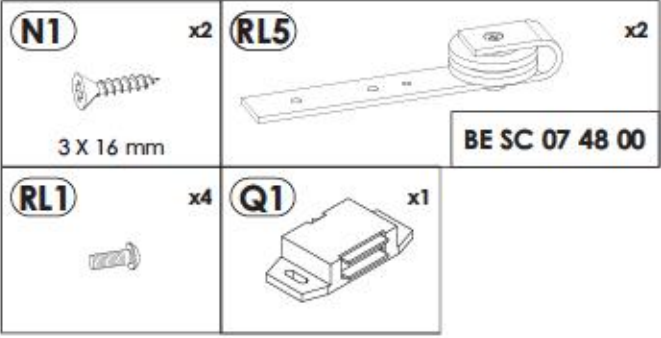

49▶

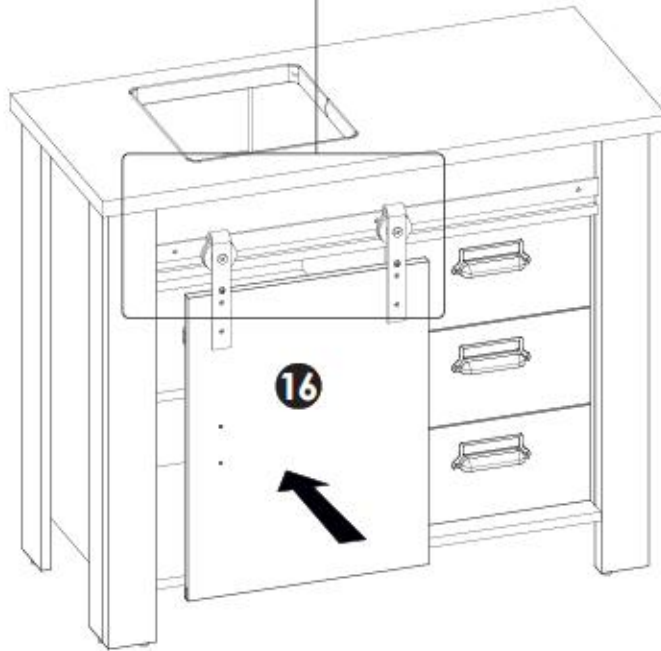
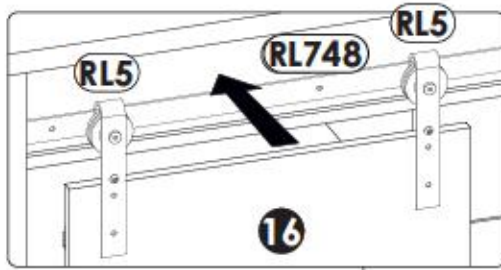

50▶

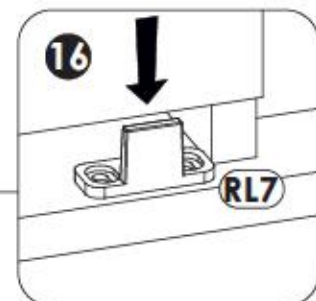
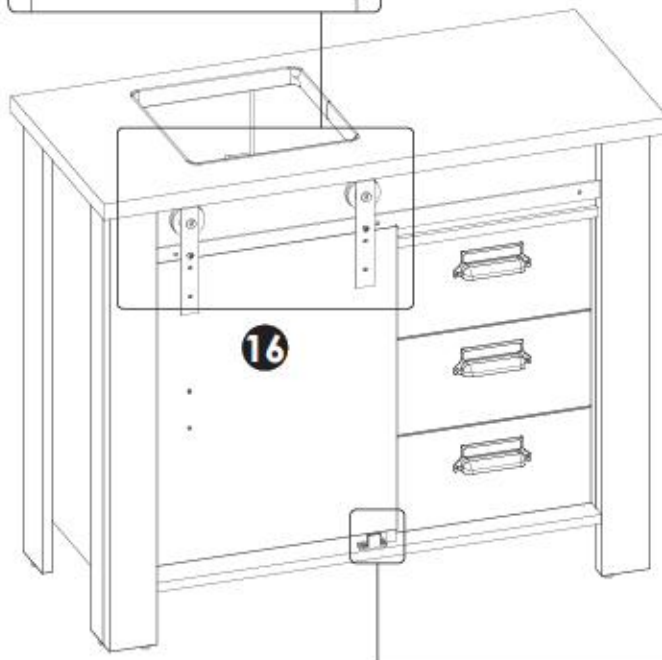
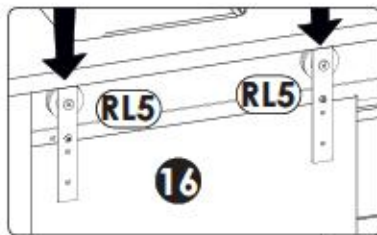

51▶

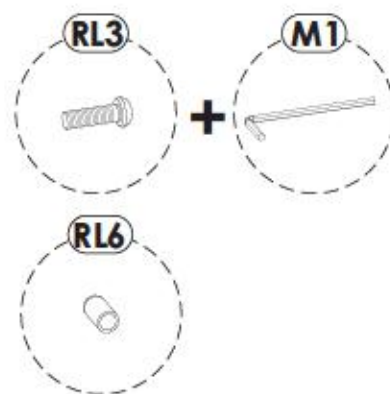
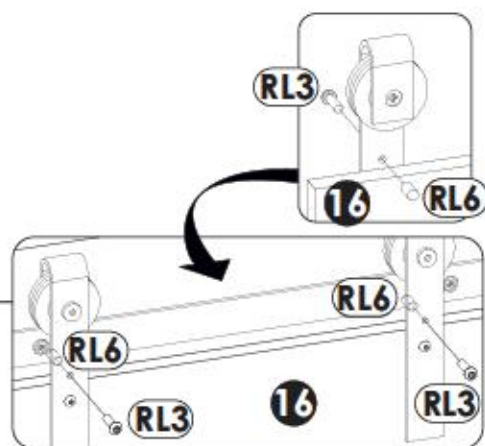
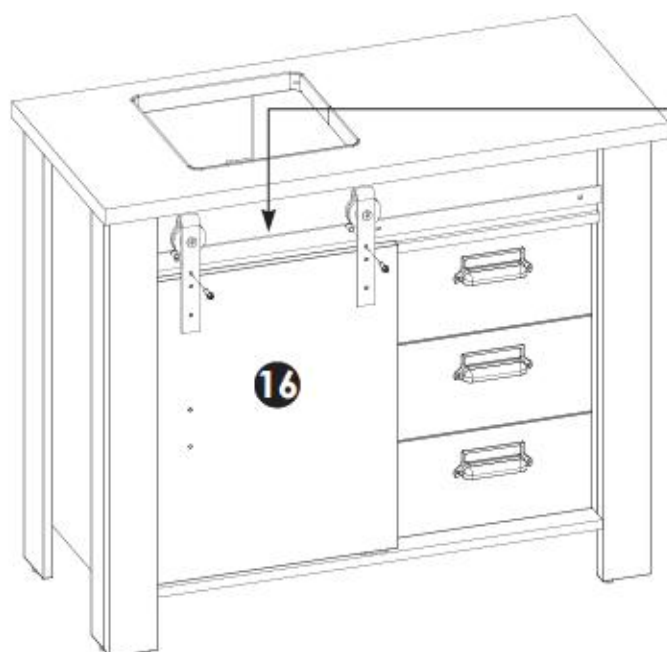
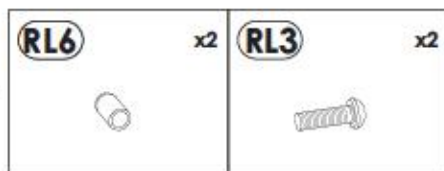

52▶

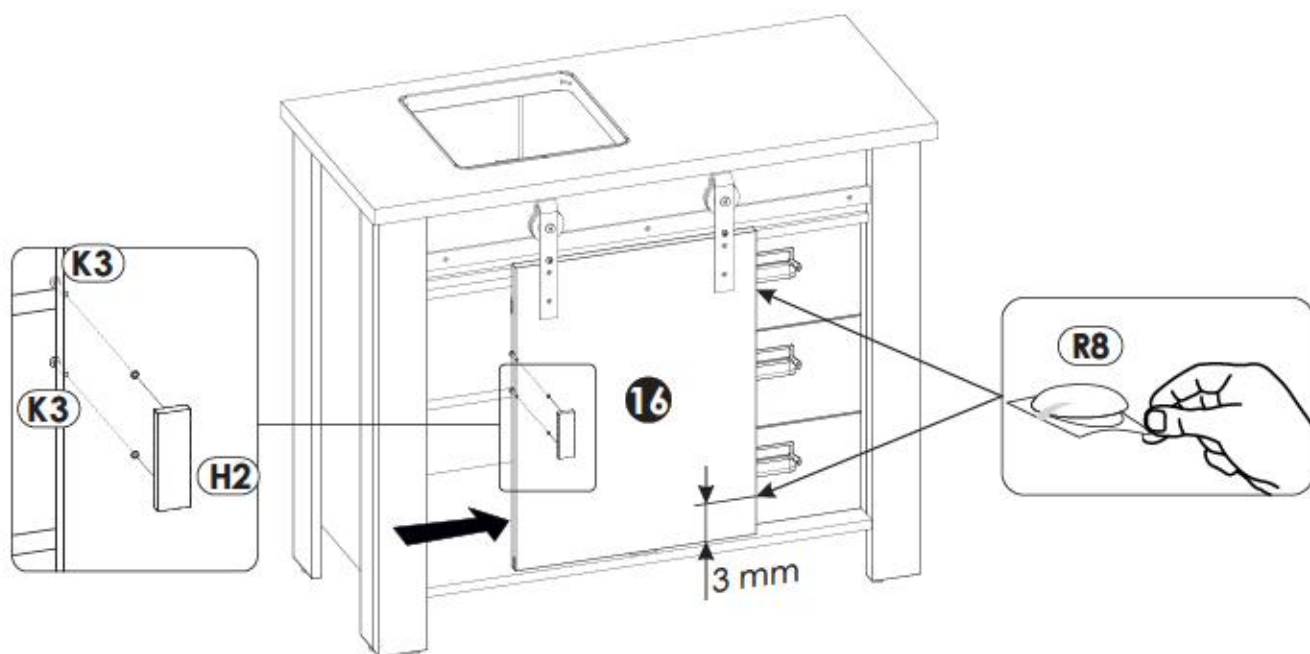
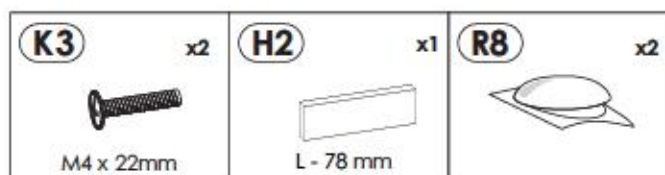

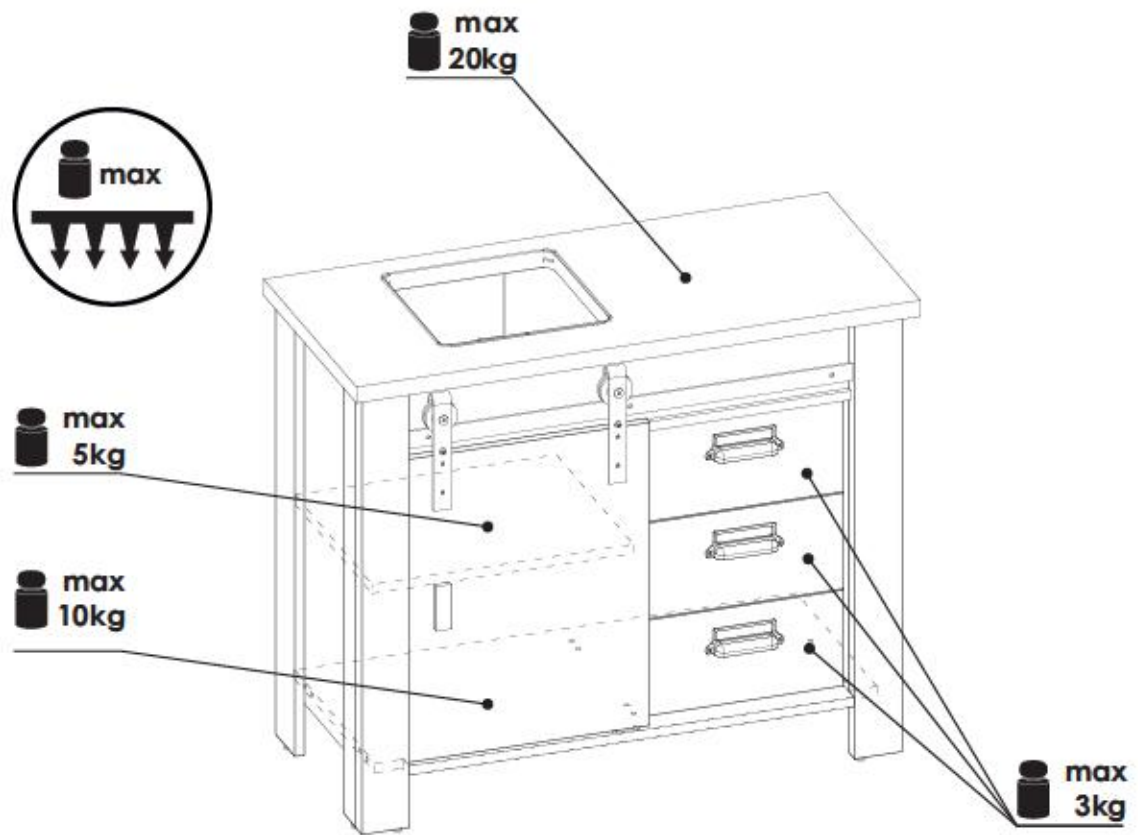

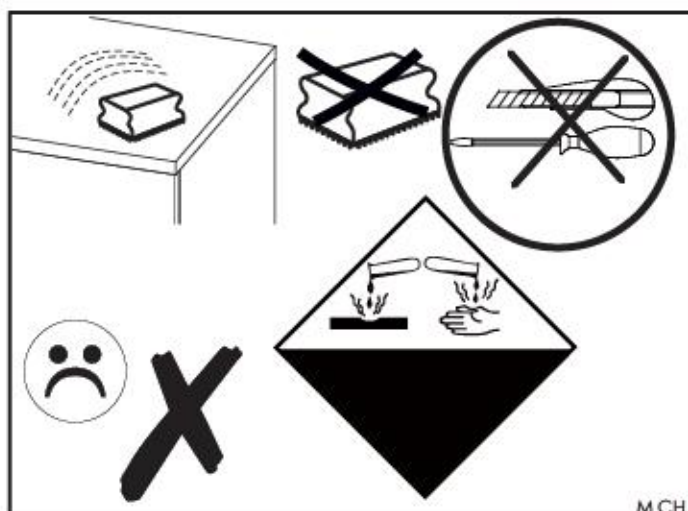
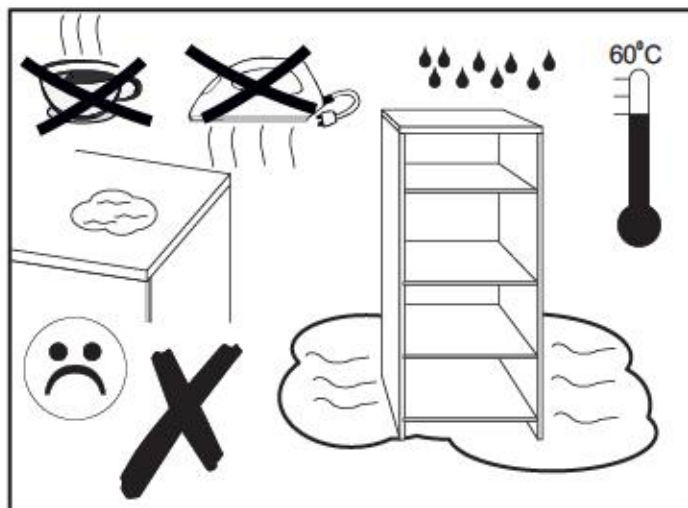
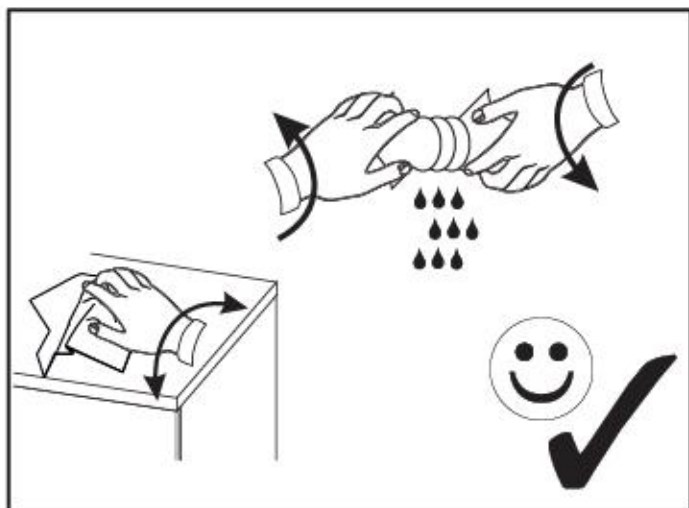
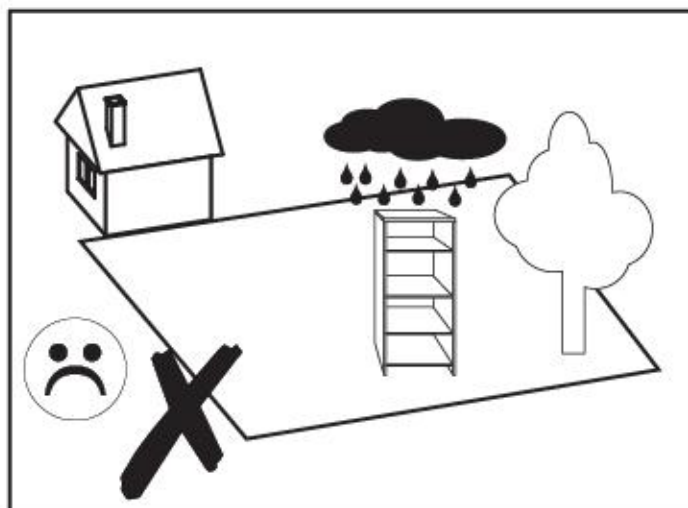
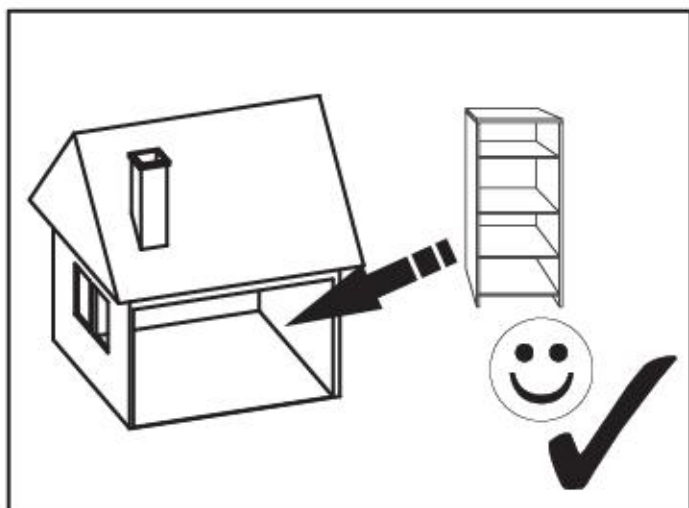

BU PRAVEJ STENE.
OV NA LAVEU ALEBO PRAVEJ STENE.

A TEJ SAMEJ ŠCIANIE CO ZAWORY KĄTOWE.

EJ LUB PRAWEJ ŠCIANIE.
MYCH W LEWEJ LUB PRAWEJ ŠCIANIE.

LEHET UGYANAZON A FALON, MINT A KÉT SAROKSZELEP.

ONALA A BAL VAGY JOBB FALON,
VONALA A BAL VAGY JOBB FALON.

НАХОДИТЬСЯ НА ОДНОЙ СТЕНЕ С УГЛОВЫМ КРАНОМ.

ИЛИ ПРАВОЙ СТЕНЕ.
НА ЛЕВОЙ ИЛИ ПРАВОЙ СТЕНЕ.

J APÅ NU ESTE ÎN ACEAS PARTE VENTIL.

SAU DREAPTA PERETE.

A STÂNGA SAU DREAPTA PERETELOR.

Zur Reinigung dürfen Sie alle üblichen flüssigen Reinigungsmittel anwenden. Vermeiden Sie alle Reinigungs-
ähnliche grosse Beimischungen enthalten. Eventuelle Oberflächenbeschädigungen (Risse, Zigarettenflecke u.
weiche Metalle oder Autos entfernen.

Die Wassertemperatur darin darf 60° C (333 K) nicht überschreiten.

Wir wünschen eine lange Lebensdauer und viel Freude an unserem Produkt und bitten Sie daher unsere Anw-
zu beachten.

Mit freundlichen Grüßen 

Dear Customer,

GB

The product you have purchased is a high quality product made of artificial marble. Due to the extremely soft
procedure we still haven't been able to completely eliminate the dimensional tolerances +/- 3 mm from the de
Please accept this with understanding.

Let an expert mount the washbasin according to the enclosed drawing.

WASHBASINCARE

Clean with standard non-abrasive cleaning agents. Minor surface damages (like scratches or cigarette stain
paste or car polish.

Never pour in the washbasin hot water the temperature of which exceeds 60° C (333 K).

We would like you to enjoy the beauty of the washbasin for a long time, therefore we recommend you to careful
and maintenance.

Yours sincerely 

NL

Geachte koper,

U heeft besteld voor de aankoop van ons kwaliteitsproduct van kunstmarmer. Vanwege het technologisch
productieproces is het ons helaas nogsteeds niet gelukt afwijkingen in de afmetingen van +/- 3mm van de in d
te sluiten. Wij verzoeken u hiervoor begrip te hebben.

De montage van de wastafel moet door een vakman worden verricht volgens de bijgevoegde tekening.

ONDERHOUD

Gebruik bij de reiniging gewone huishoudschoonmaakmiddelen, die niet krassen. Eventuele oppervlaktebe-
sigaretten) kunnen gemakkelijk met een poetsmiddel voor zachte metalen of autolak verwijderd worden.

Giet geen water met een temperatuur van boven de 60° C (333 K) in de wastafel.

Wij hopen dat u veel en langdurig plezier van de wastafel zult hebben. Daarom verzoeken wij u onze a
onderhoud nauwkeurig in acht te nemen.

Met vriendelijke groeten 

Cher Client,

FR

Le produit que vous venez d'acheter est un produit de haute qualité réalisé en marbre artificiel. Vu l'ext
procédure technologique, nous ne parvenons toujours pas à éliminer totalement l'écart de ± 3 mm des dir
technique. Nous faisons appel à votre compréhension.

Adressez-vous à un expert pour que la montage du lavabo soit conforme au croquis annexé.

ENTRETIEN DU LAVABO

Bästa kund,

SE

Du har valt att köpa en högkvalitetsprodukt av konstgjord marmor. Då den teknologiska processen vid tillverkningen av produkten är ytterst krävande, kan vi tyvärr inte alltid garantera den angivna dimensionsavvikelsen +/- 3mm. Vi ber om förståelse.

Tvättstället ska monteras av en erfaren yrkesman i överensstämmelse med bifogade instruktionsritningar.

UNDERHÅLL AV TVÄTTSTÄLLET

Vid rengöring av tvättstället ska vanliga flytande rengöringsmedel användas. Använd inte rengöringsmedel som innehåller finmalen sand eller liknande partiklar. Eventuella ytliga skador (repor, cigarettfläckar) kan avlägsnas med poleringsmedel, som används för rengöring av mjuka metaller eller billack.

Vattentemperaturen får inte överstiga 60 grader.

Vi önskar Dig stor glädje med produkten i många år framöver och ber Dig därför noga följa anvisningarna för rengöring och underhåll.

Med lyckönskningar **emotion**

Arvoisa asiakas

FI

Olet hankkinut korkealaatuisen marmorijäljitelmästä valmistetun tuotteen. Teknisesti vaativan ja yksilöllisen valmistusmenetelmän vuoksi emme voi valitettavasti aina sulkea pois mahdollisuutta, että mitat saattavat poiketa +/-3 mm ilmoitetuista mitoista.

Pesualtaan asennus tulee antaa asiantuntijan suoritettavaksi oheisen piirroksen mukaisesti.

PESUPÖYDÄN HOITO

Puhdistamiseen voi käyttää kaikkia yleisiä nestemäisiä puhdistusaineita. Vältä sellaisia puhdistusaineita, jotka sisältävät hienoksi jauhettua hiekkaa tai samankaltaisia sekoituksia. Mahdolliset pintavauriot (säröt, savukkeen jättämät tahrat jne.) voidaan poistaa pehmeälle metallille tai autolle tarkoitetuilla kiillotusaineilla.

Puhdistusveden lämpötila ei saa ylittää 60° C.

Jotta tuotteen käyttöikä olisi mahdollisimman pitkä, pyydämme Sinua noudattamaan puhdistus- ja huolto-ohjeitamme.

Ystävällisin terveisin **emotion**

Kære kunde,

DK

Du har valgt at anskaffe et produkt af høj kvalitet lavet af kunstmarmor. Fordi produktionen er teknologisk meget krævende, er det ikke lykkedes os altid at overholde den deklarerede tolerance på +/- 3mm. Vi beder om forståelse.

Vasken bør monteres af en erfaren fagmand, som det fremgår af den vedlagte tegning.

VEDLIGEHODELSE AF VASKEN

Til vedligeholdelse anvendes almindelige flydende rengøringsmidler. Undgå at anvende rengøringsmidler som indeholder fint malet sand eller lignende tilsætningsstoffer. Eventuelle overfladeskader (ridser, cigaret pletter) fjernes med et poleringsmiddel, som anvendes til polering af bløde metalfader og vedligeholdelse af billak.

Vandtemperaturen må ikke overstige 60° C.

Vi håber du vil få glæde af produktet i mange år, derfor beder vi dig følge vejledningen for rengøring og vedligeholdelse.

Venlig hilsen **emotion**

Vážený zákazník!

CZ

Rozhodli jste se pro zakoupení vysoce kvalitního výrobku z umělého mramoru. Jelikož je výroba tohoto výrobku po technologické stránce velmi náročná, nepodařilo se nám vždy zajistit deklarovanou odchylku o rozměru +/- 3 mm. Žádáme vás proto o porozumění.

Teplota vody nesmí přesahovat 60° C.

Doporučujeme vám, aby umyvadlo zamontoval zkušený odborník podle přiloženého návodu.

ÚDRŽBA UMYVADLA

Pro čištění používejte obvyklé tekuté čisticí prostředky. Nepoužívejte čističů, která obsahují jemně mletý písek nebo podobné příměsy. Případné poškození povrchu (poškrábání, skvrny od cigaret) odstraňte leštidlem určeným pro čištění měkkých kovů nebo lakovaného povrchu karoserie aut.

Přejeme vám, aby jste byli s naším výrobkem spokojeni a aby vám co nejdéle sloužil. Proto vás prosíme, aby jste se řídili podle našich návodů pro čištění a údržbu.

Vaše **emotion**

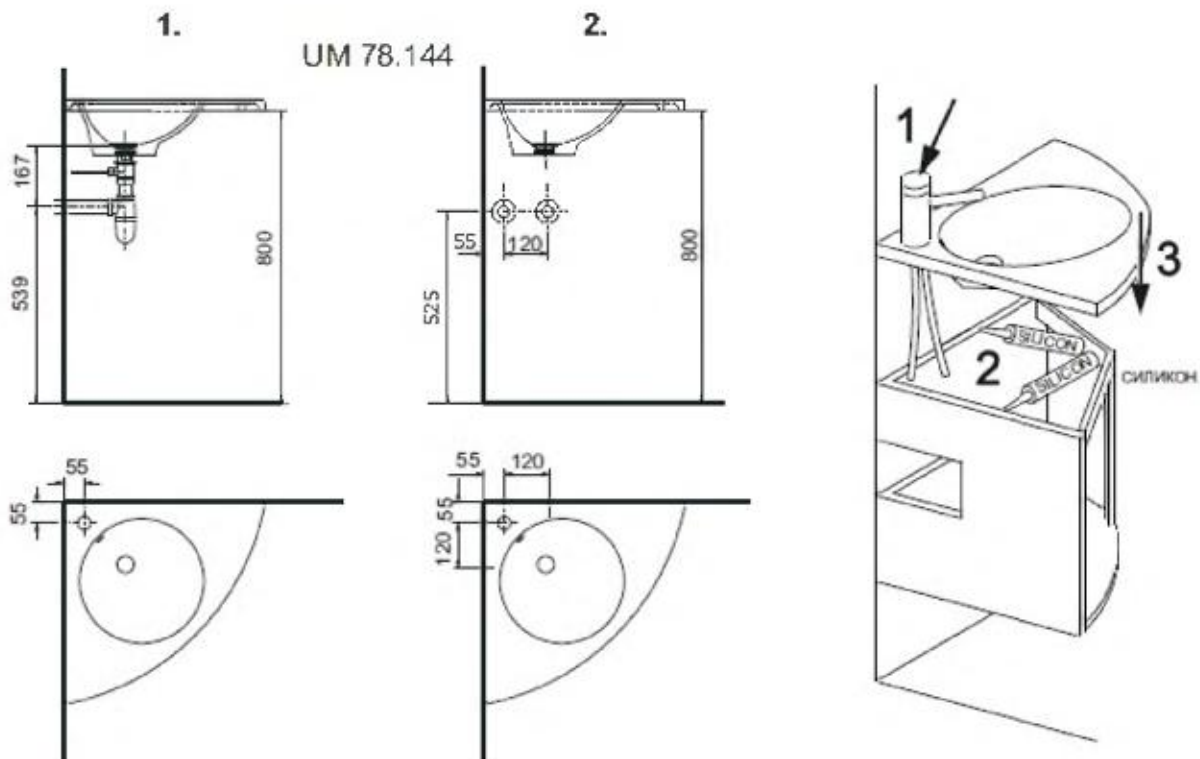

DE DER AUSFLUSS UM DARF SICH NICHT AN DER SELBEN WAND WIE DIE ECKVENTILE BEFINDEN.

1. ZENTRUM DES AUSFLUSSES IN LINKER ODER RECHTER WAND.
2. ZENTRUM DER ECKVENTILE AN LINKER ODER RECHTER WAND.

GB MAKE SURE THE WATER OUTLET IS NOT ON THE SAME WALL AS THE ANGLE VALVES.

1. THE CENTRE OF THE OUTLET ON THE LEFT OR ON THE RIGHT WALL.
2. THE CENTRE OF THE ANGLE VALVES ON THE LEFT OR ON THE RIGHT WALL.

NL DE AFVOERPIJP VAN DE GOOTSTEEN MAG NIET AAN DEZELFDE MUUR ZIJN ALS DE HOEKVENTIELEN.

1. MIDDENPUNT VAN DE AFVOERPIJP AAN DE LINKER- OF RECHTERKANT VAN DE MUUR.
2. MIDDENPUNT VAN DE HOEKVENTIELEN AAN DE LINKER- OF RECHTERKANT.

FR L'ÉCOULEMENT DU LAVABO NE DOIT PAS SE TROUVER SUR LE MEME MUR QUE LES SOUPAPES.

1. LE CENTRE DE L'ÉCOULEMENT AU MUR GAUCHE OU DROIT.
2. LE CENTRE DES SOUPAPES AU MUR GAUCHE OU DROIT.

SE SE TILL ATT VATTENAVLOPPET INTE ÄR PÅ SAMMA VÄGG SOM VINKELVENTILERNA.

1. AVLOPPETS CENTRUM PÅ VÄNSTRA ELLER HÖGRA VÄGGEN.
2. VINKELVENTILERNAS CENTRUM PÅ VÄNSTRA ELLER HÖGRA VÄGGEN.

FI VEDEN POISTOPUTKI EI SAA OLLA SAMALLA SEINÄLLÄ KUIN VEDEN TULOLIITÄNNÄN KULMAVENTTIILIT.

1. POISTOPUTKEN KESKIKOHTA VASEMMALLA TAI OIKEALLA SEINÄLLÄ.
2. TULOLIITÄNNÄN KULMAVENTTIILIIEN KESKIKOHDAT VASEMMALLA TAI OIKEALLA SEINÄLLÄ.

DK SØRG FOR, AT VANDUDLØBET IKKE ER PÅ SAMME VÆG SOM VINKELVENTILERNE.

1. MIDTEN AF UDLØBET PÅ VENSTRE ELLER HØJRE VÆG.
2. MIDTEN AF VINKELVENTILERNE PÅ VENSTRE ELLER HØJRE VÆG.

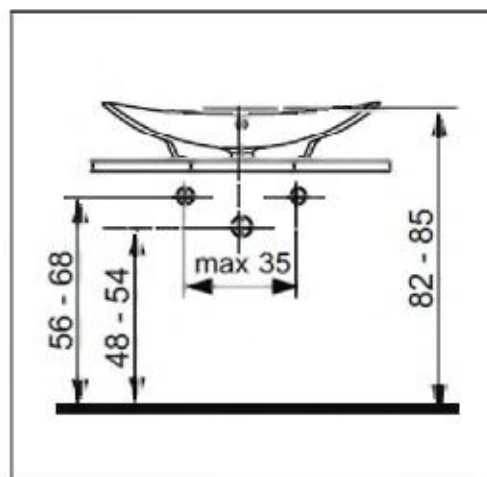
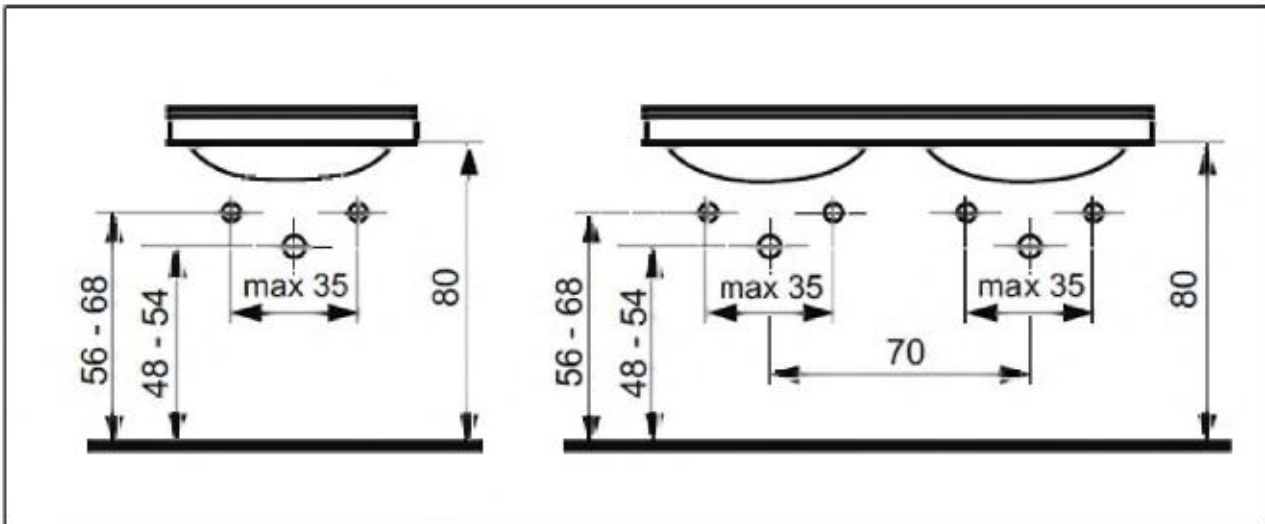
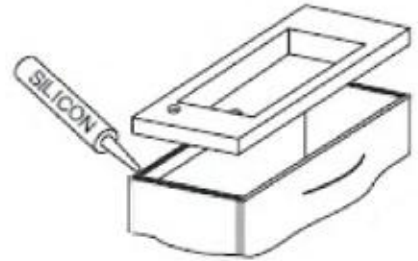
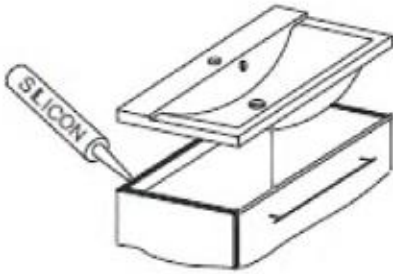
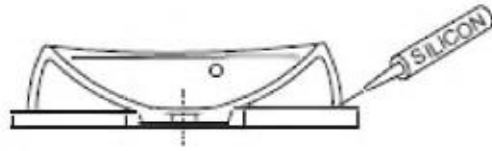

Vážení zákazníci,

SK

rozhodli ste sa pre nákup vysokoakostného výrobku z umelého kameňa. Keďže je technologický výrobný postup veľmi náročný, sa nám nepodarilo vždy zabezpečiť deklarovaný odklon rozmerov ± 3 mm. Prosíme o Vaše pochopenie.

Umývadlo musí pripevniť skúsený odborník v súlade s priloženým náčrtom.

ÚDRŽBA UMÝVADLA

Na čistenie používajte obyčajné tekuté čistiace prostriedky. Nepoužívajte prostriedky, obsahujúce jemne mletý piesok alebo podobné prímеси. Prípadné poškodenia povrchu (ryhy, cigaretové škvrny) odstráňte leštiacim prostriedkom, ktorý je vhodný na čistenie mäkkých kovov alebo ošetrovanie automobilového laku.

Teplota vody nesmie byť vyššia ako 60° C (333 K).

Želáme Vám, aby Vám výrobok slúžil k spokojnosti ešte dlhé roky, preto Vás prosíme o dodržiavanie nášho návodu na čistenie a údržbu.

Vaše 

Szanowny Kliencie,

PL

Zdecydowałeś się na zakup naszego cechującego się wysoką jakością wyrobu ze sztucznego marmuru. Ze względu na wymagającą technologicznie, indywidualną metodę produkcji nie zawsze jest niestety możliwe wykluczenie odchyłek wymiarów od deklarowanych wartości, wynoszących do ± 3 mm. Prosimy o zrozumienie.

Montaż umywalki powinien być wykonywany przez fachowca zgodnie z załączonym szkicem.

PEŁĘGNOWANIE BLATU UMYWALKI

Do czyszczenia można używać wszystkich ogólnie dostępnych ciekłych środków czyszczących. Unikać wszelkich środków czyszczących, które zawierają drobno mielony piasek lub podobne dodatki. Ewentualnie uszkodzenia powierzchni (rysy, plamy z papierosów itp.) można usuwać środkami do polerowania przeznaczonymi do metali miękkich lub lakierów samochodowych.

Temperatura wody nie może przekraczać 60° C (333 K).

Życzymy długiego okresu użytkowania i wiele satysfakcji z posiadania naszego produktu i prosimy o przestrzeganie naszych instrukcji odnośnie czyszczenia i konserwacji.

Z poważaniem 

Tisztelt Vevőnk!

HU

Őn kiváló minőségű műmárvány termék mellett döntött. A termék nagyon bonyolult előállítási technológiája miatt sajnos nem tudtuk elérni, hogy mindig biztosíthatjuk a deklarált ± 3 mm méreteltérést. Megértésüket köszönjük.

A mosdókagylót tapasztalt szakemberrel szereltesse fel a mellékelt rajz alapján.

A MOSDÓKAGYLÓ KARBANTARTÁSA

Tisztításához használjon hagyományos folyékony tisztítószereket. Ne használjon finomra darált homokot vagy hasonló anyagokat tartalmazó tisztítószereket. Az esetleges felületi sérüléseket (karcolásokat, cigaretta foltokat) puha fémek tisztítására vagy autó ápolására szolgáló polírozószerezrel távolítsa el.

A víz hőmérséklete nem lehet 60° C-nál magasabb.

Kívánjuk, hogy a termékben hosszú éveken át örömet lelje, ezért kérjük, tartsa be a termék tisztítására és karbantartására vonatkozó útmutatónkat.

A vállalat, amely Önért van 

Estimado cliente:

ES

Agradecemos la decisión tomada al comprar nuestro producto de alta calidad, compuesto por resinas sintéticas y polvo de mármol. Estos componentes no nos permiten siempre poder fabricar medidas exactas, por lo que tengan en cuenta que debe haber una tolerancia ± 3 mm.

Para su montaje, sigan rigurosamente las instrucciones incluidas, anexas a este documento.

Mantenimiento:

Para su limpieza, no se deben utilizar productos agresivos ni abrasivos, que podrían dañar la superficie. Para posibles manchas de cigarro o rayadas superficiales, utilizar un pulimento para metales blandos o para pintura para coches.

La temperatura del agua no debe sobrepasar los 60°.

Deseamos que disfrute de la decisión de compra de nuestro producto y recordarle que es muy importante que siga las instrucciones de mantenimiento.

Atentamente 

Уважаемый покупатель,

RUS

Продукт, который Вы приобрели, является высококачественным продуктом, изготовленным из искусственного мрамора. Несмотря на чрезвычайно усовершенствованный и специфический технологический процесс мы все же не в состоянии были полностью устранить отклонения +/-3 мм от заявленных размеров в технической спецификации. Пожалуйста, отнеситесь к этому с пониманием.

Установку умывальной раковины в соответствии с приложенной схемой доверьте специалисту.

УХОД ЗА УМЫВАЛЬНОЙ РАКОВИНОЙ

Чистите стандартными неабразивными чистящими средствами. Незначительные повреждения поверхности (такие как царапины или пятна от сигарет) могут быть удалены полировальной пастой для металла или автомобильным полиролем.

Никогда не наливайте в умывальную раковину воду, температура которой превышает 60° C (333 K).

Мы желаем Вам наслаждаться красотой умывальной раковины в течение долгого времени, поэтому рекомендуем Вам выполнять все инструкции по очистке и уходу.

Искренне ваше **emotion**

RO

Drag cumpărător,

Produsul pe care lăști cumpărat este de înaltă calitate produsul din punct facut din mermerii mari. Din cauză remarcabilă sofisticate și specific tehnologic procese mai mult nu suntem la posibilitatea pentru a elimina complet dimensională toleranță +/-3 mm declarat informații în domeniul tehnic fications. Vă rog să asta ne rugam să primiți cu înțelegere.

Pentru a construicia chiuvetă ih conformitate cu a aproximativ desenului.

ÎNȚREȚINERE CHIUVEȚĂ

Întreținere chiuvetă curațați standard nomabrazivă în formațiuni agenci de curațare. Suprafața minimă precjiciu (cum ar fi zgăriturile sau o pñă de cigară) pot fi lusturită metalul sau mașina.

Nici odata nu trebuie să bieți apă palda că-i temperatură trecu 60°(333 k)

Vă dorim mult timp să vă bucurați în frumusețe chiuvetă, asa sa vă recomandă să fiț atent instrucția pentru curățenie și întreținere cu

respect **emotion**

UM 42.185

