

WICHTIG – FÜR SPÄTERE VERWENDUNG AUFBEWAHREN- SORGFÄLTIG LESEN

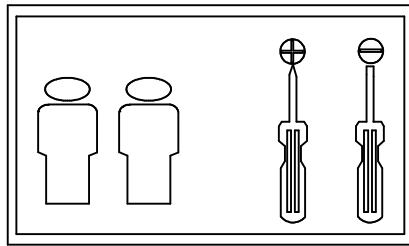

Schardt GmbH & Co. KG
 Am Riegel 15
 96268 Mitwitz
 Tel. 09266/9907-0
 Fax 09266/9907-77
 eMail: info@schardt.com

Montageanleitung - Assembly instructions - Instructions de montage - Montageaanwijzing

Kombikinderbett Sienna 04 230

Inhalt - Contents - Contenu - Inhoud

A M6 x 60 10 x	B 12/13 Metall 10 x	
C 2 x	D 2 x	
E 4 x	F 1 x	G 6,3 x 50 4 x

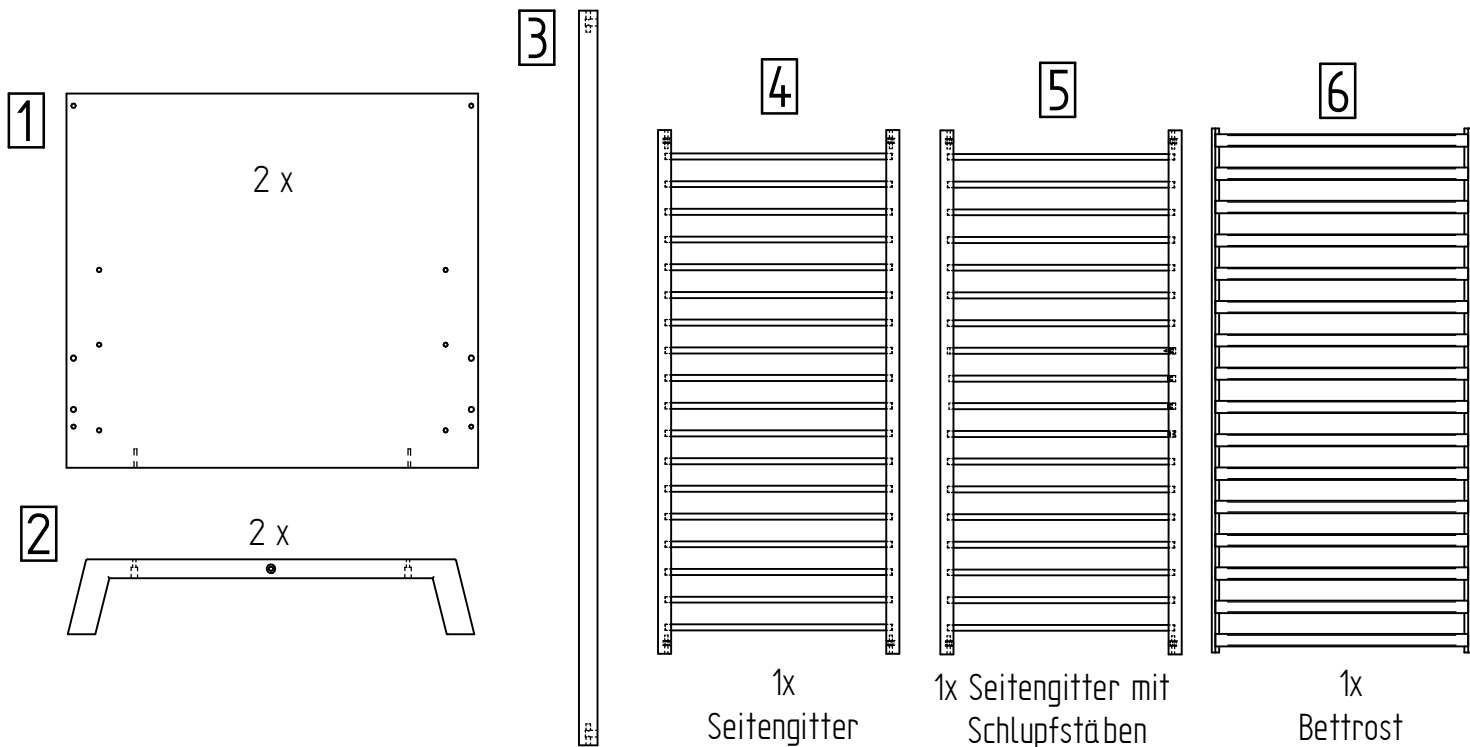

Vormontage Rosthaken

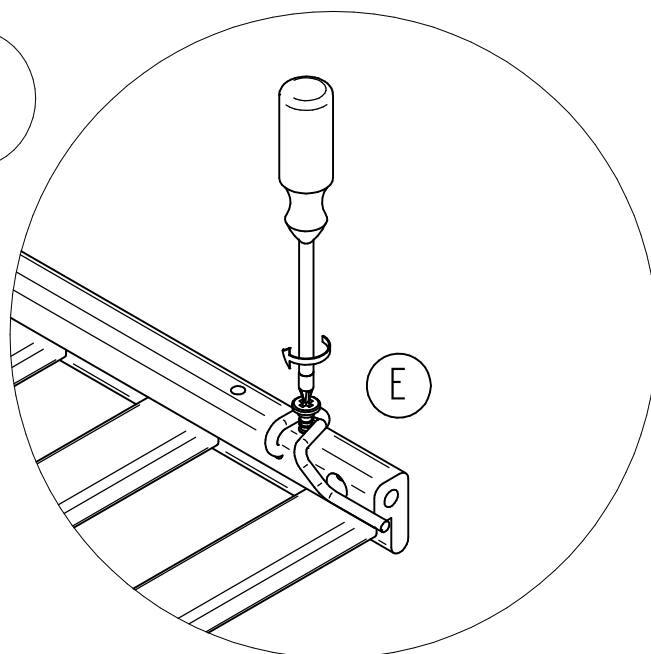
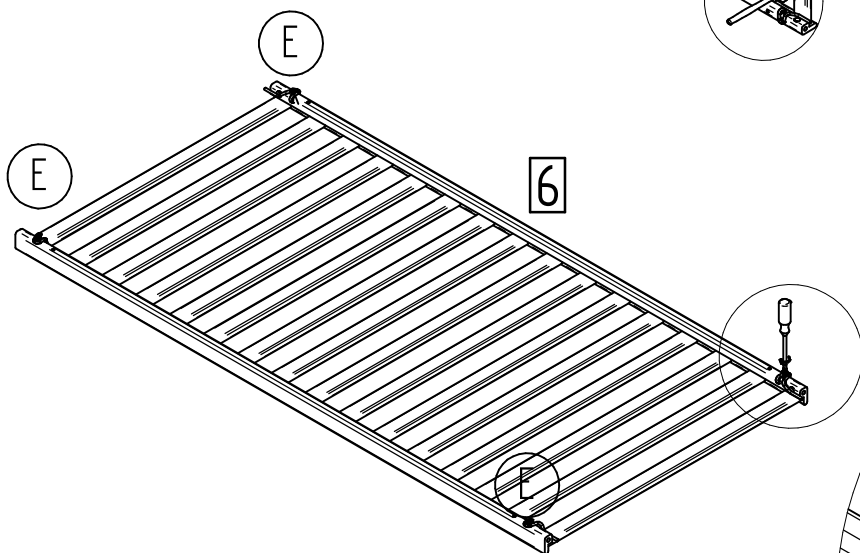
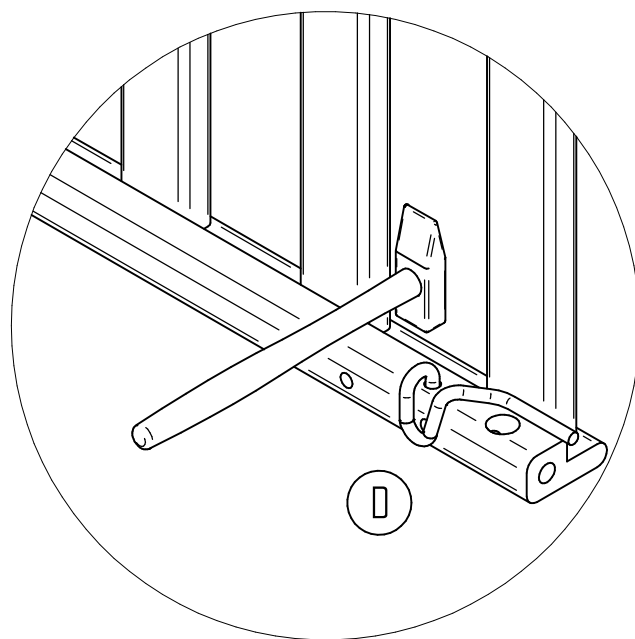
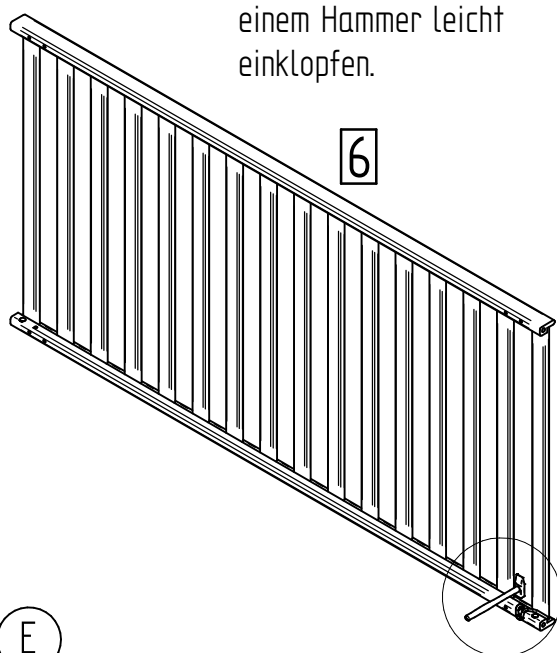
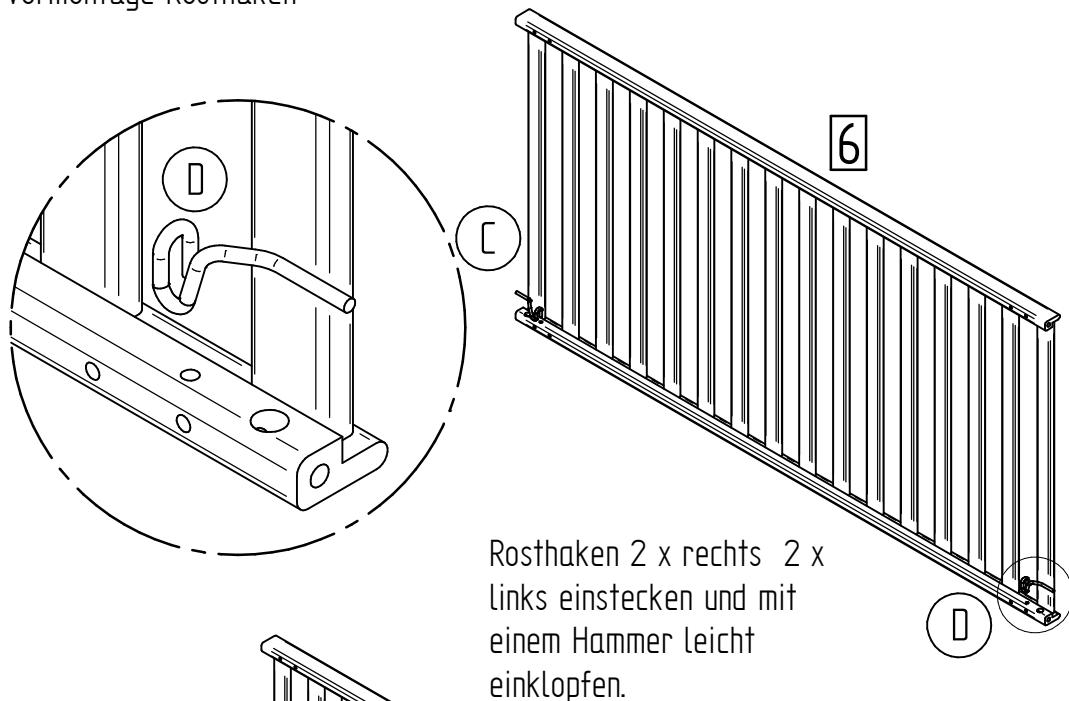

Alle 4 Rosthaken verschrauben! Beim Einbau des Rostes in das Bett sind die Rosthaken unten!

Gitter mit Schlupfstäben so einsetzen, dass die Federn der Schlupfstäbe oben sind.

A

5

4

A

1

A

A

B

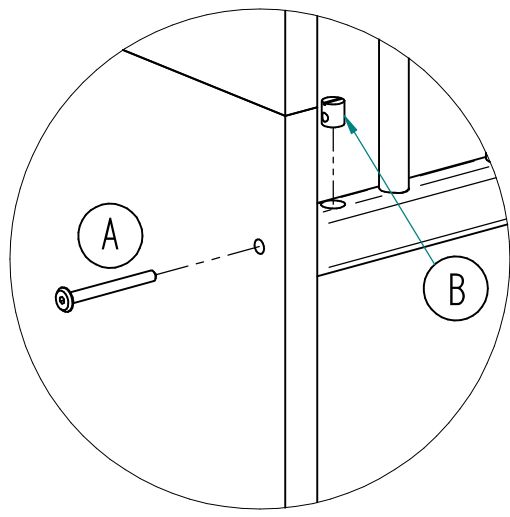

Bett vorsichtig mit 2 Personen aufstellen.

A

A

1

A

A

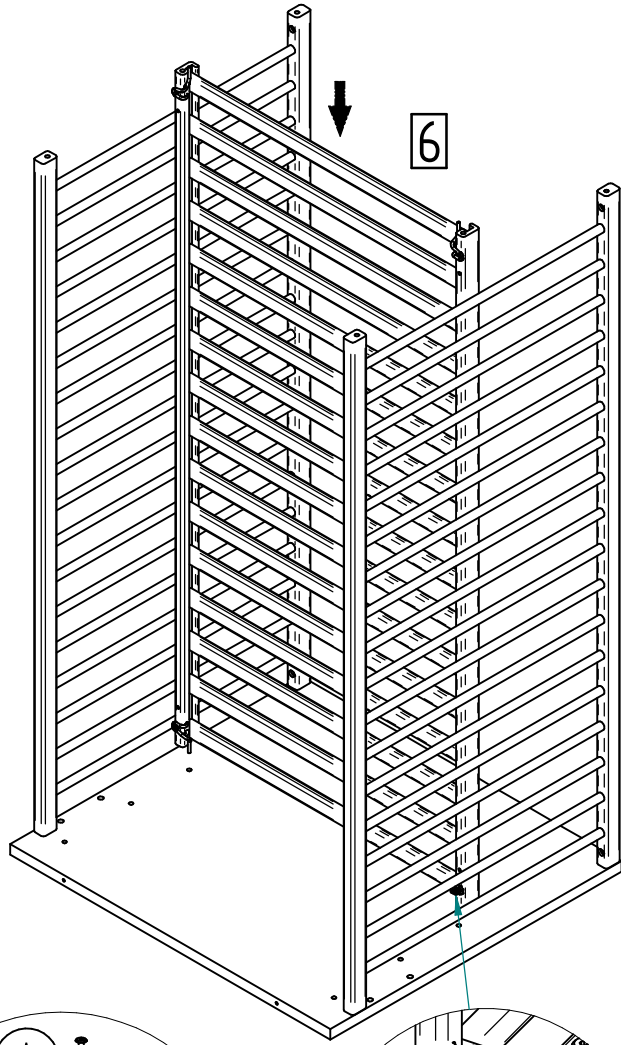

6

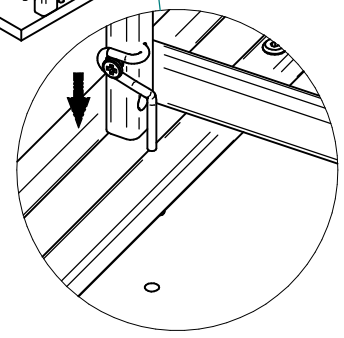
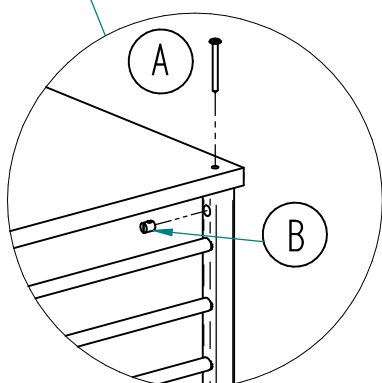
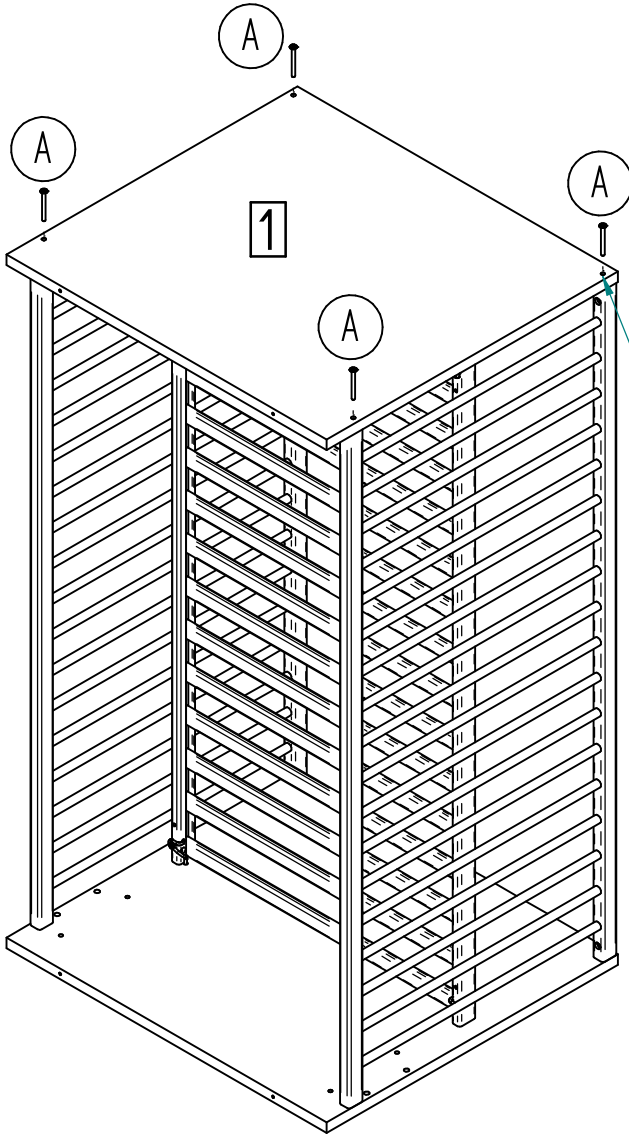

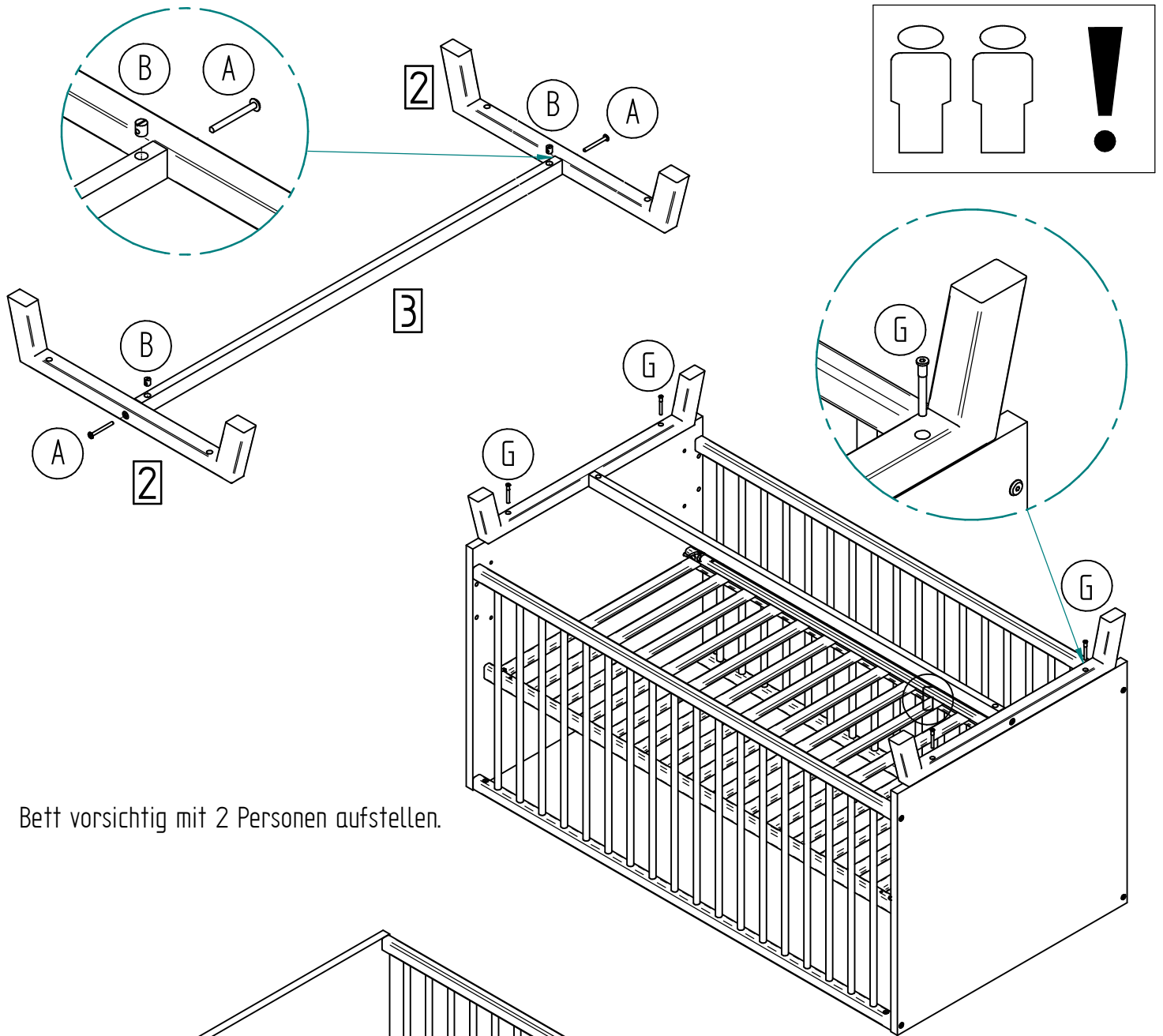



Bett vorsichtig mit 2 Personen aufstellen.



Beim Herausnehmen der Schlupfstäbe sind immer alle Stäbe zu entfernen, um unzulässige Öffnungsmaße zu vermeiden.

Umbau zum Juniorbett 04 254

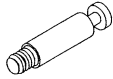
Inhalt - Contents - Contenu - Inhoud

A 	B 
8 x	8 x

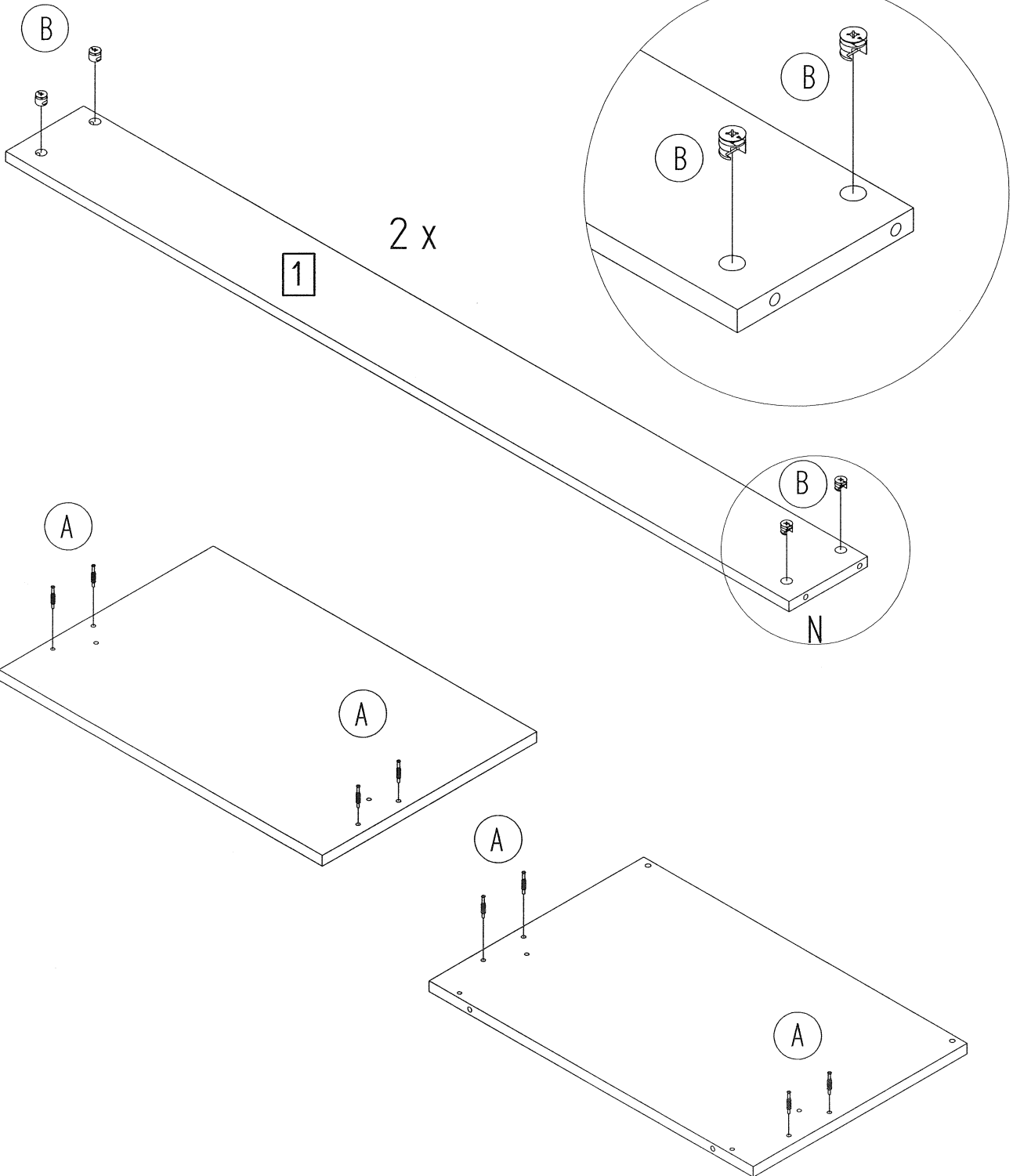
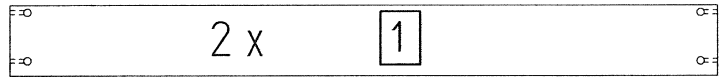

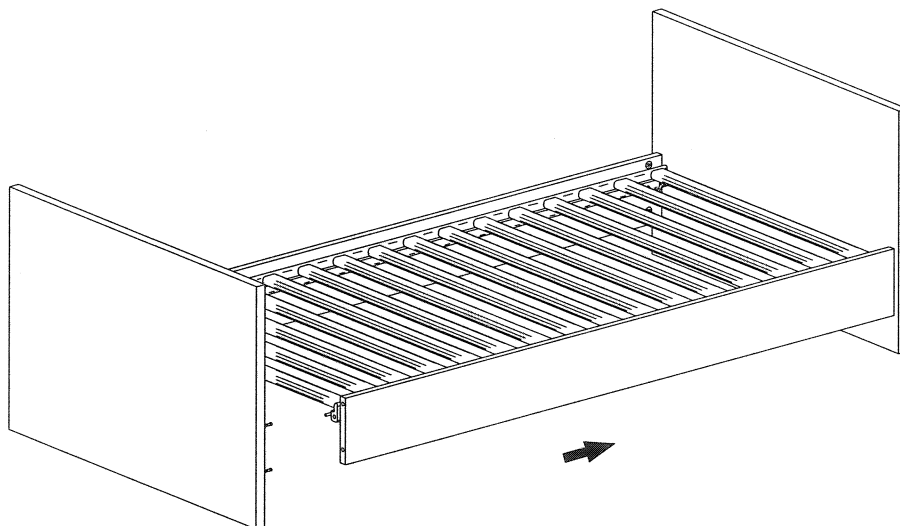
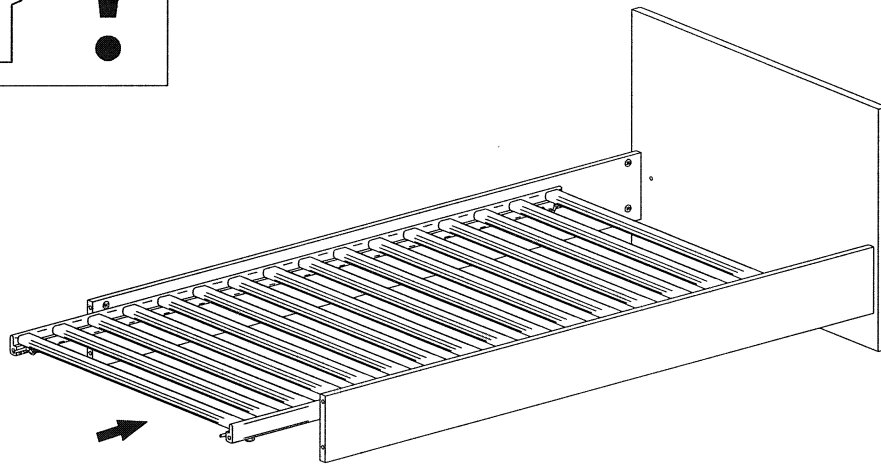
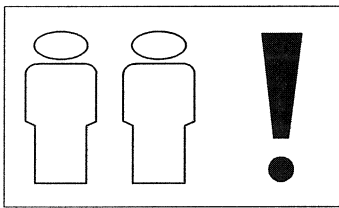
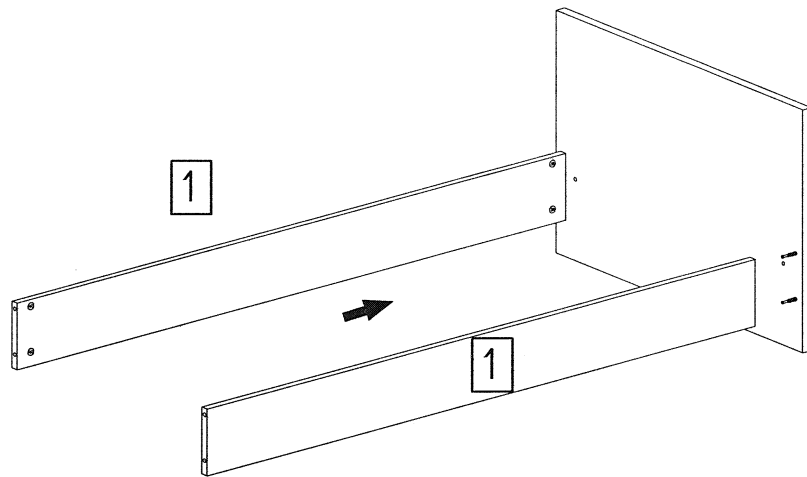

Maximale Belastung des Juniorbettes 30 kg!





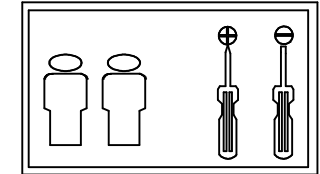





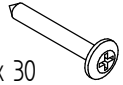

Inhalt - Contents - Contenu - Inhoud - contenuto -contenido-conteúdo - περιεχόμενο

Wickelkommode changing unit Commode Kommode

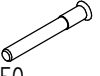

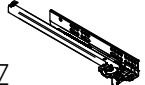
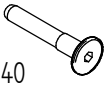
Wiko Sienna 3 Schübe 05 231 Typ 1

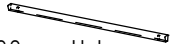
DIN EN 12221:2008+A1:2013

A  8 x	B  15/16 8 x	
C  8 x 30 2 x	D  4 x 30 1 x	E  1 x
G  SW 4 1 x	H  12 x	I  6,3 x 50 8 x
K  SEZ 3 X 450 mm	L  SEZ 3 X 450 mm	M  7 x 40 5 x
N  M4 x 20 6 x	O  288 mm Holz 3 x	P  6,3 x 9 12 x



Inhalt - Contents - Contenu - Inhoud - contenuto - contenido-conteúdo - περιεχόμενο

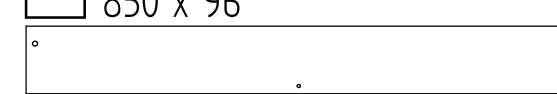
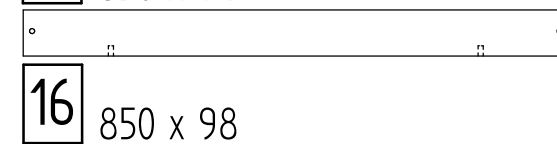
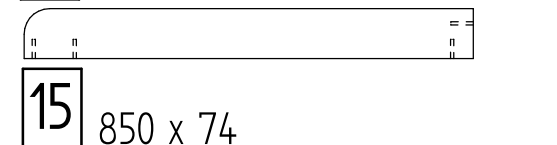
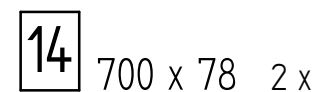
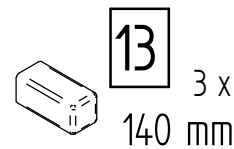
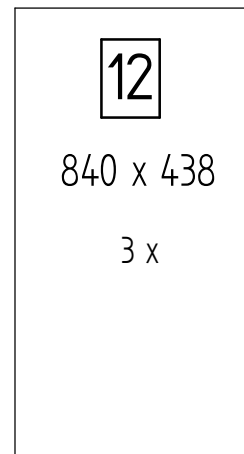
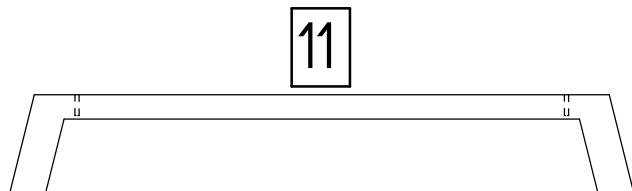
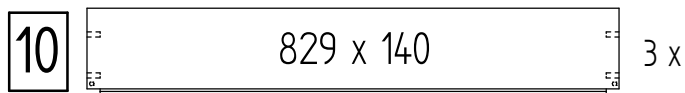
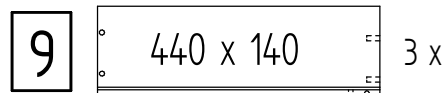
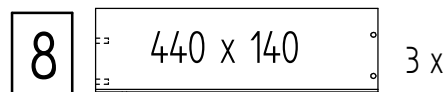
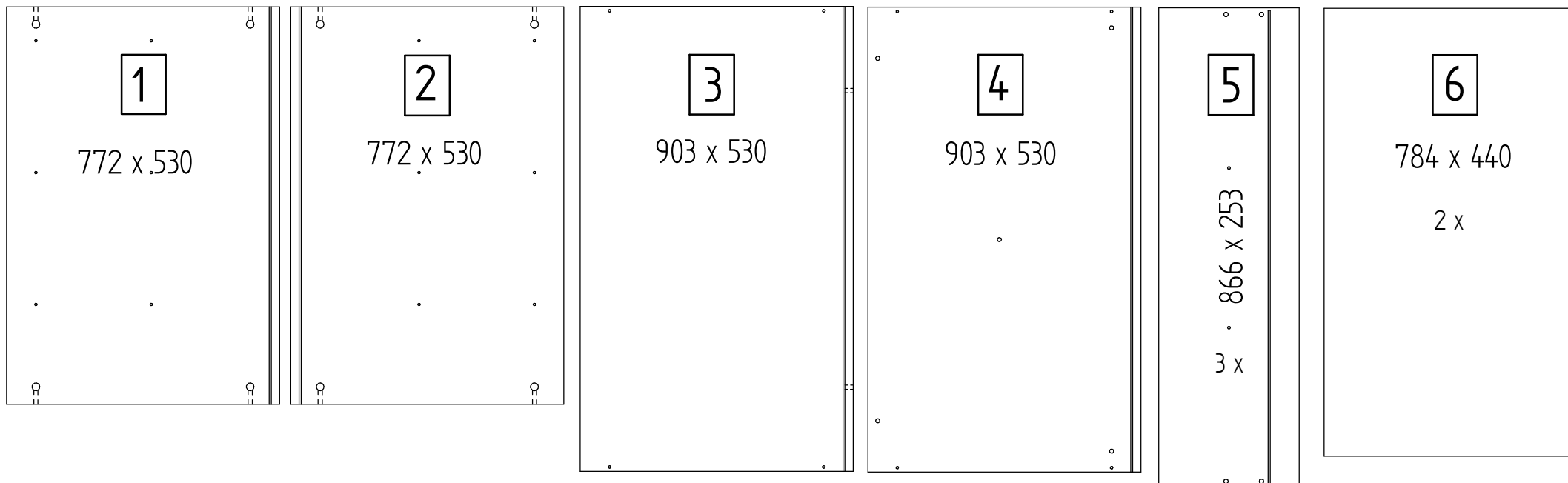

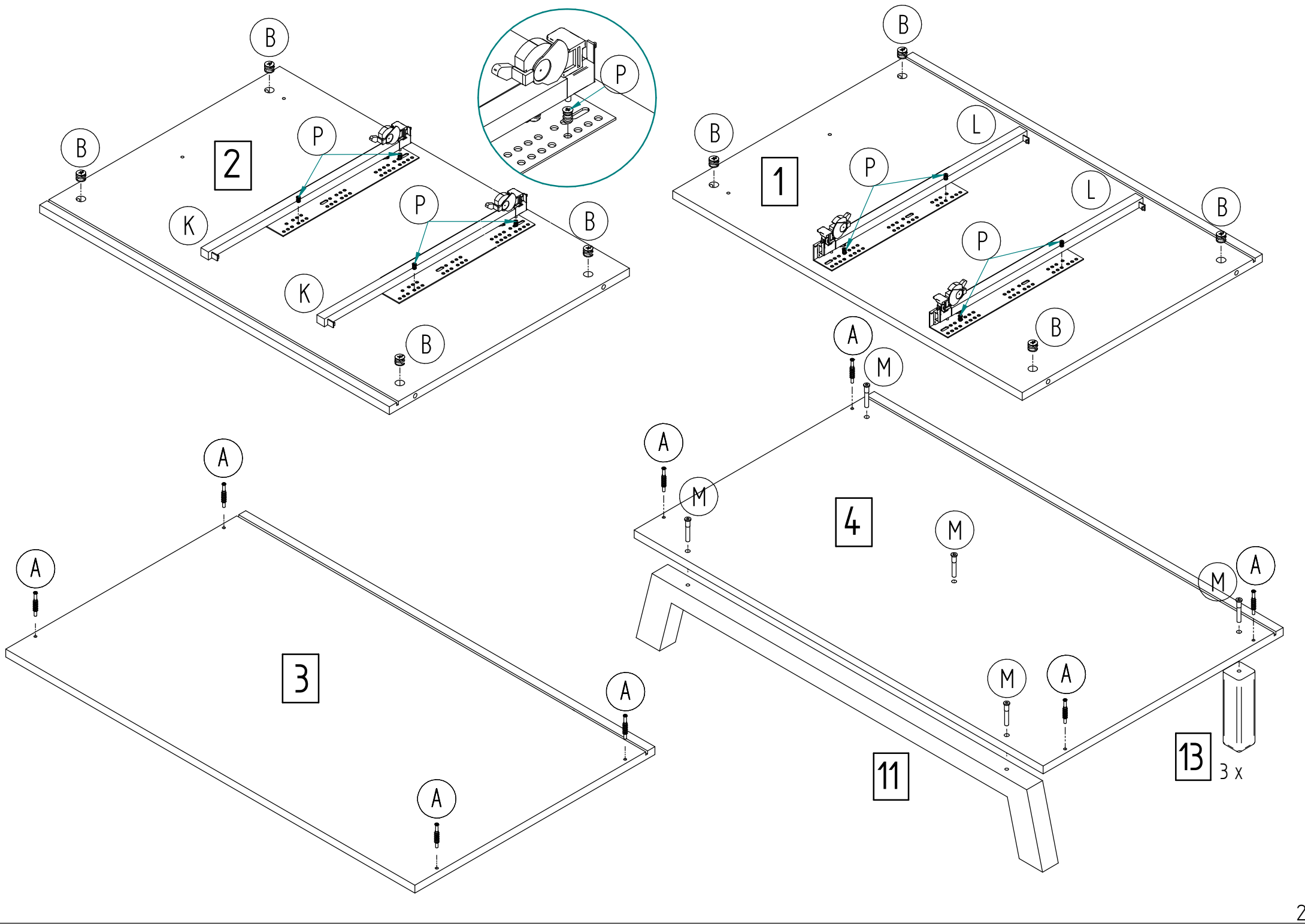

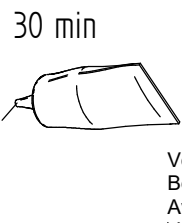
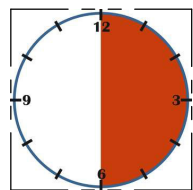
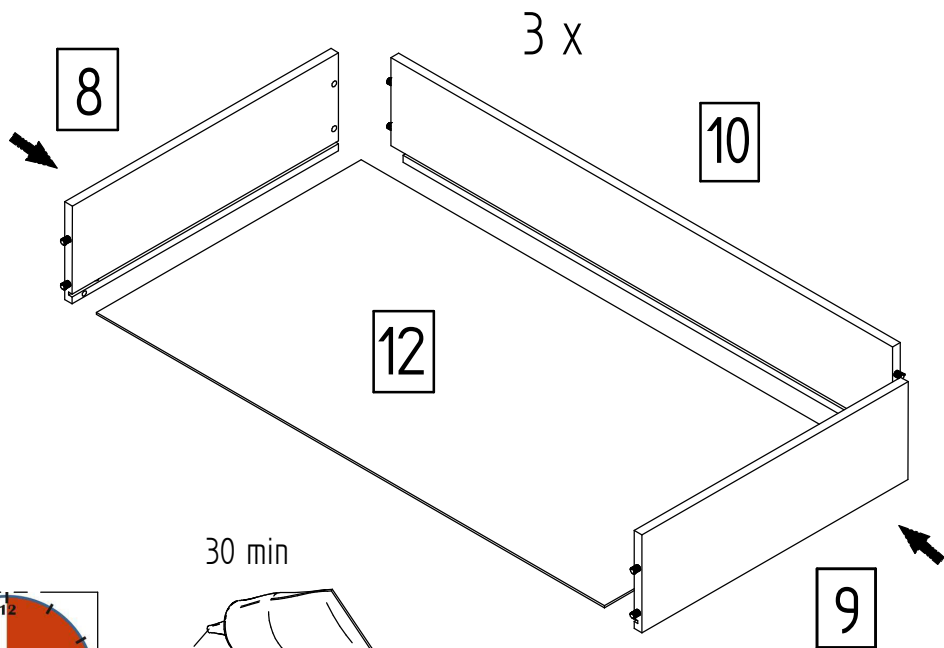

Vor weiterer Montage der Beschläge den Leim 30 min abbinden lassen.
 Before further installation of the fittings the glue thicken for 30 minutes.
 Avant l'installation ultérieure des raccords, la colle épaissir pendant 30 minutes.
 Voor verdere montage van het beslag de lijm dik gedurende 30 minuten.
 Prima ulteriore installazione dei raccordi addensare la colla per 30 minuti.
 Antes de la instalación posterior de los accesorios de la cola espesar durante 30 minutos.
 Antes da instalação posterior dos acessórios a engrossar cola durante 30 minutos.
 Πριν από την περαιτέρω εγκατάσταση των εξαρτημάτων πικνώνει η κόλλα για 30 λεπτά.

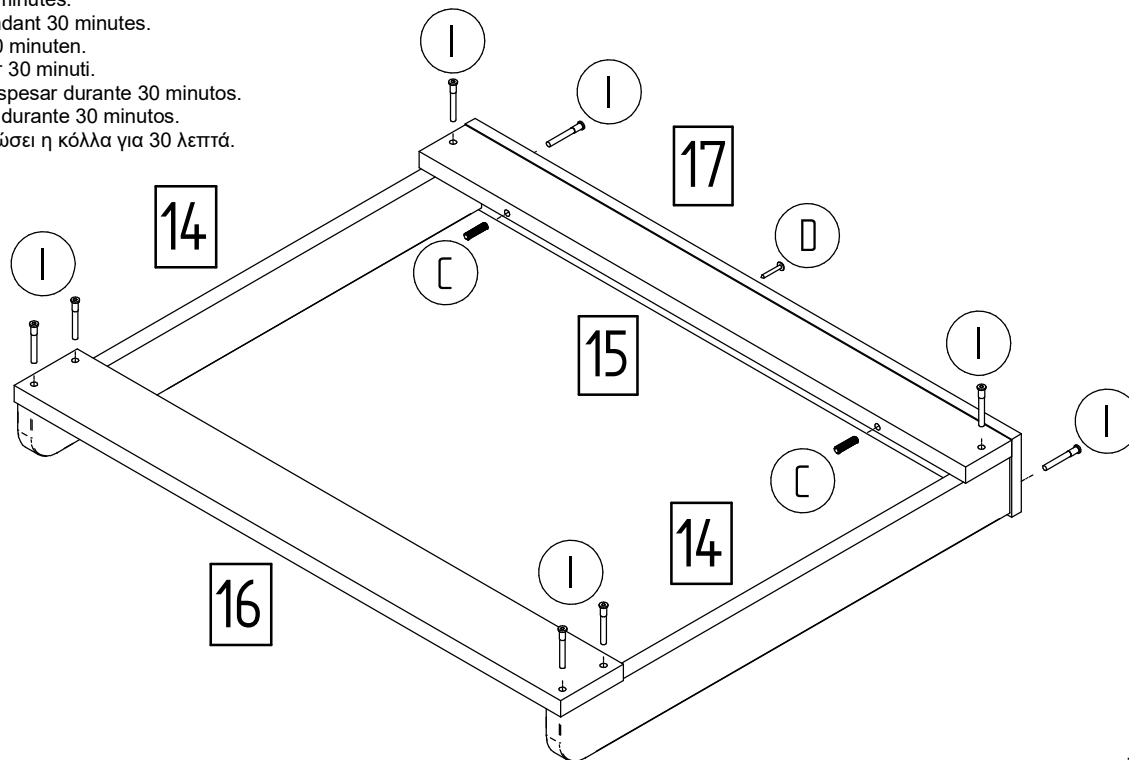
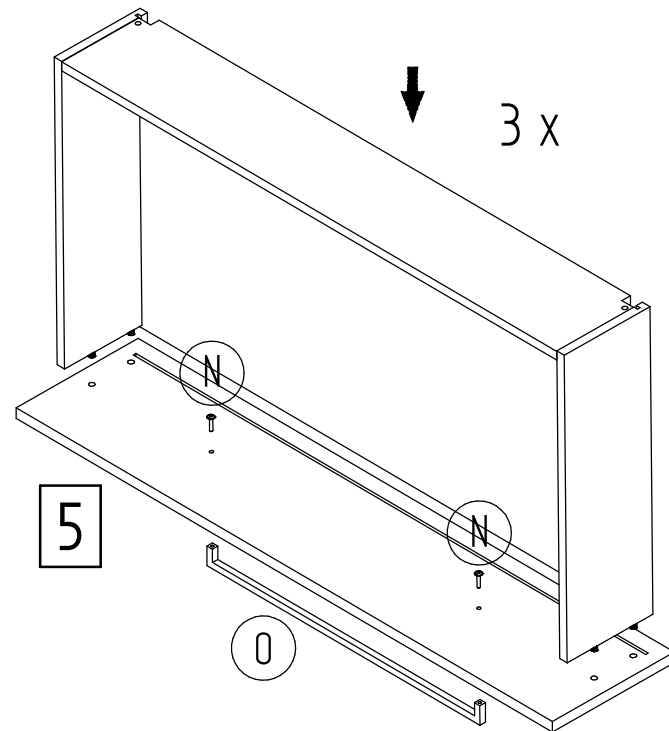
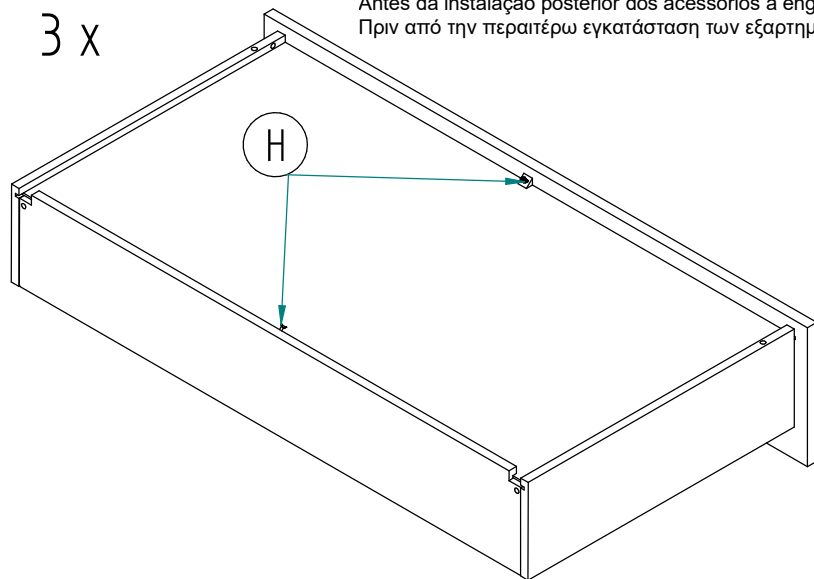

2

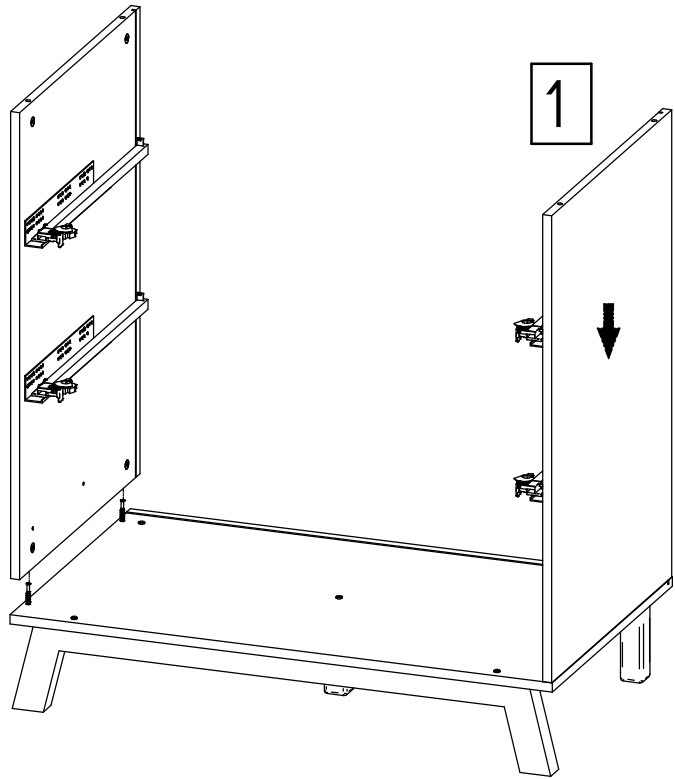

1

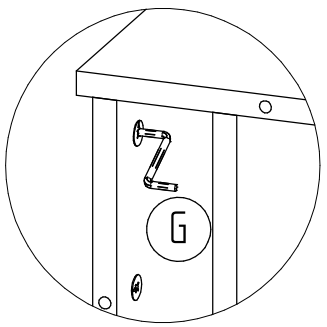
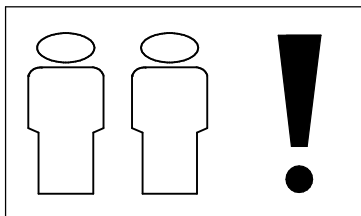

3

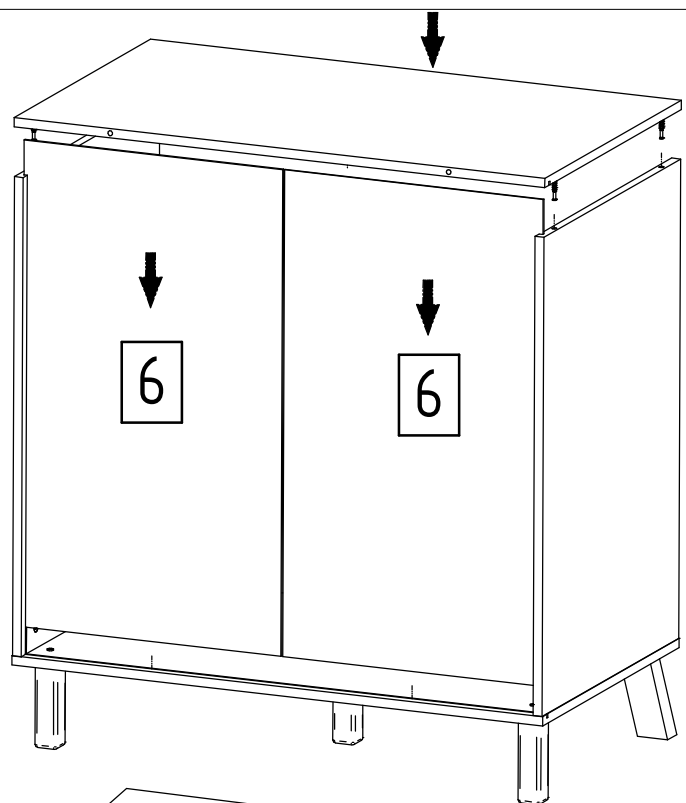

6

6

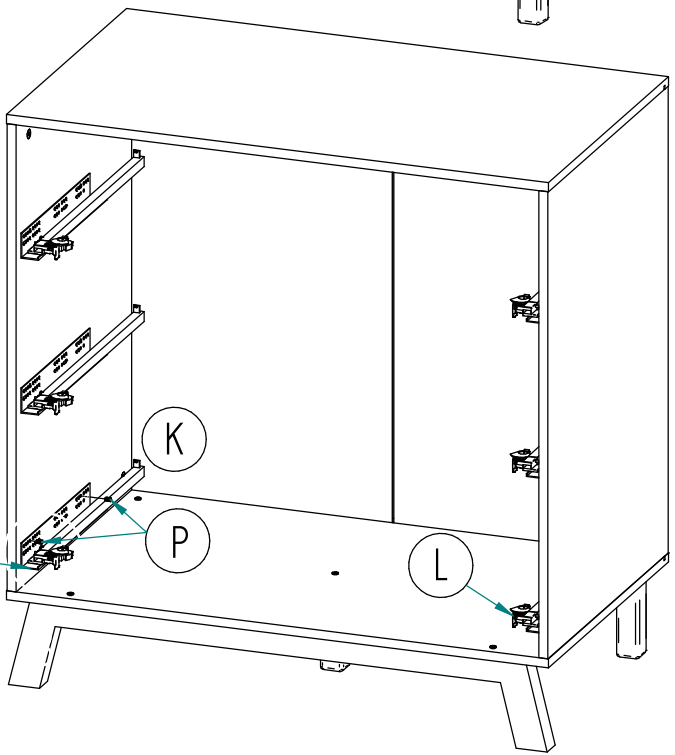
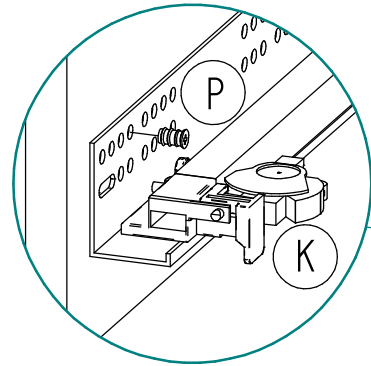
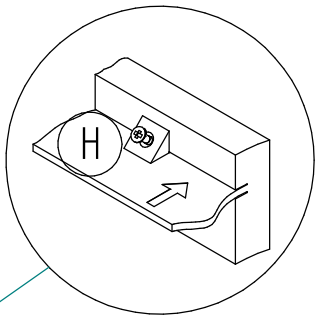
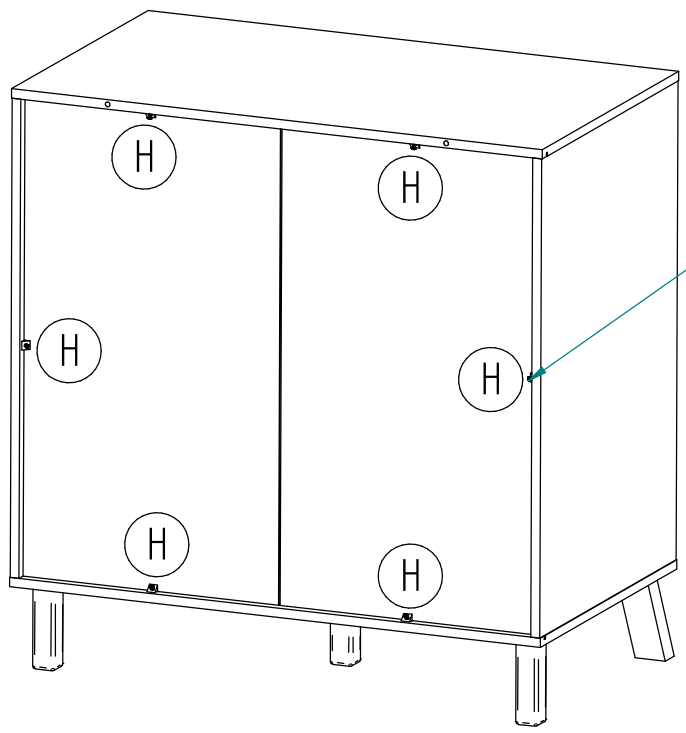

K

P

L

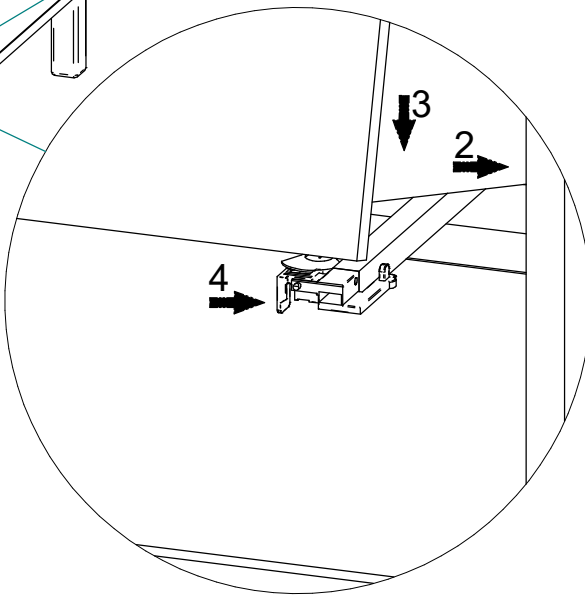
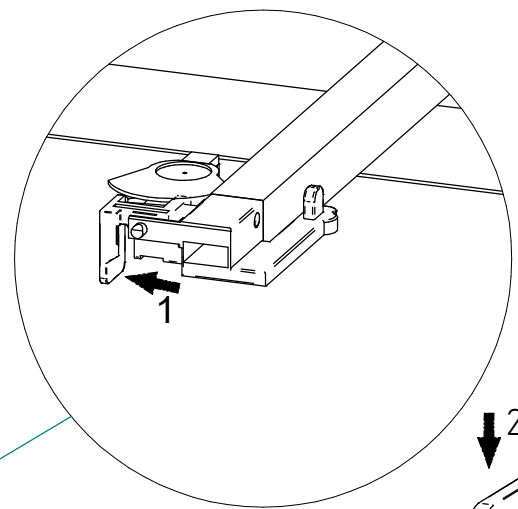
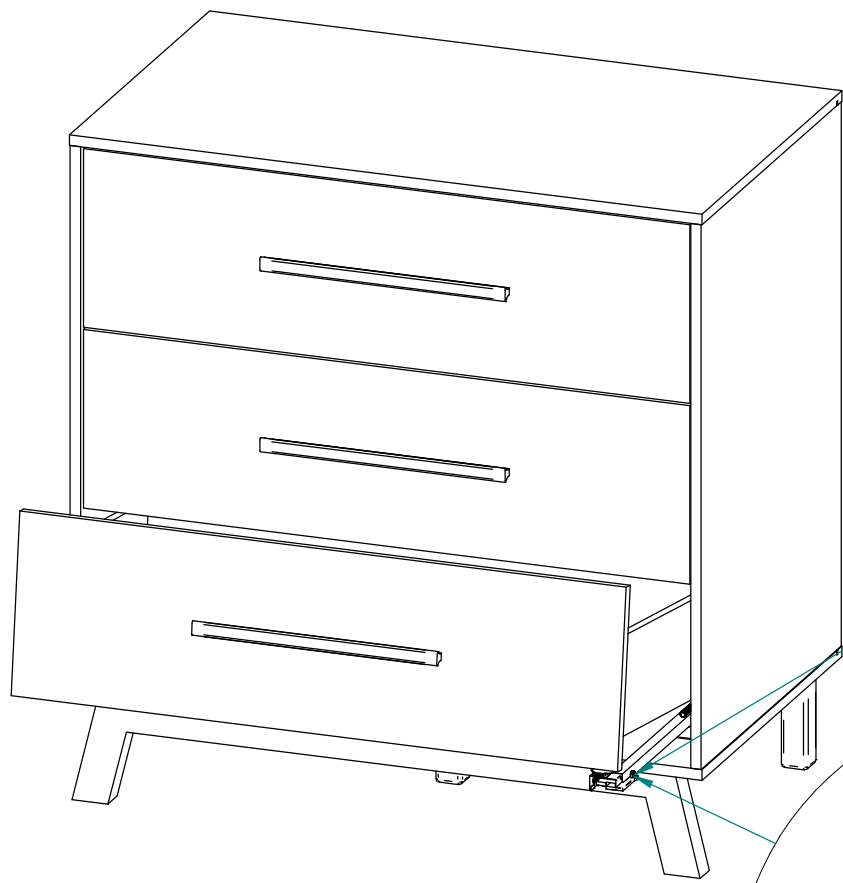



Achtung !

Wird die Wickelkommode an der Wand befestigt , muss das Montagematerial der Beschaffenheit der Wand entsprechen !

Attention !

If the baby changing table is attached to the wall the assembly material has to be appropriate for the composition of the wall !

Attention !

Si la table á langer est attachée au mur il doit être approprié le matériel d'assamblage pour la composition du mur !

Attenzione !

Si il fasciatoio é fortificato al muro il deve essere appropriato il materiale di montaggio alla composizione del muro !

... weitere Infos über unsere Produkte unter
... plus d' informations sur nos produits sous
... altre informazione degli prodotti di noi sotto

www.schardt.com

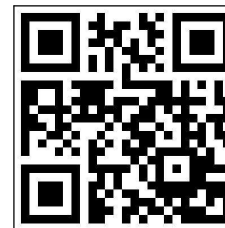

Schardt GmbH & Co. KG
Am Riegel 15
96268 Mitwitz
Tel. 09266/9907-0
Fax 09266/9907-77
E-Mail: info@schardt.com