

Pneumatic rod upholstered bed apricot color
Pneumatische Stange Polsterbett apricot Farbe
Tige pneumatique lit rembourré couleur abricot

B021009(140x200)
B021009(160x200)

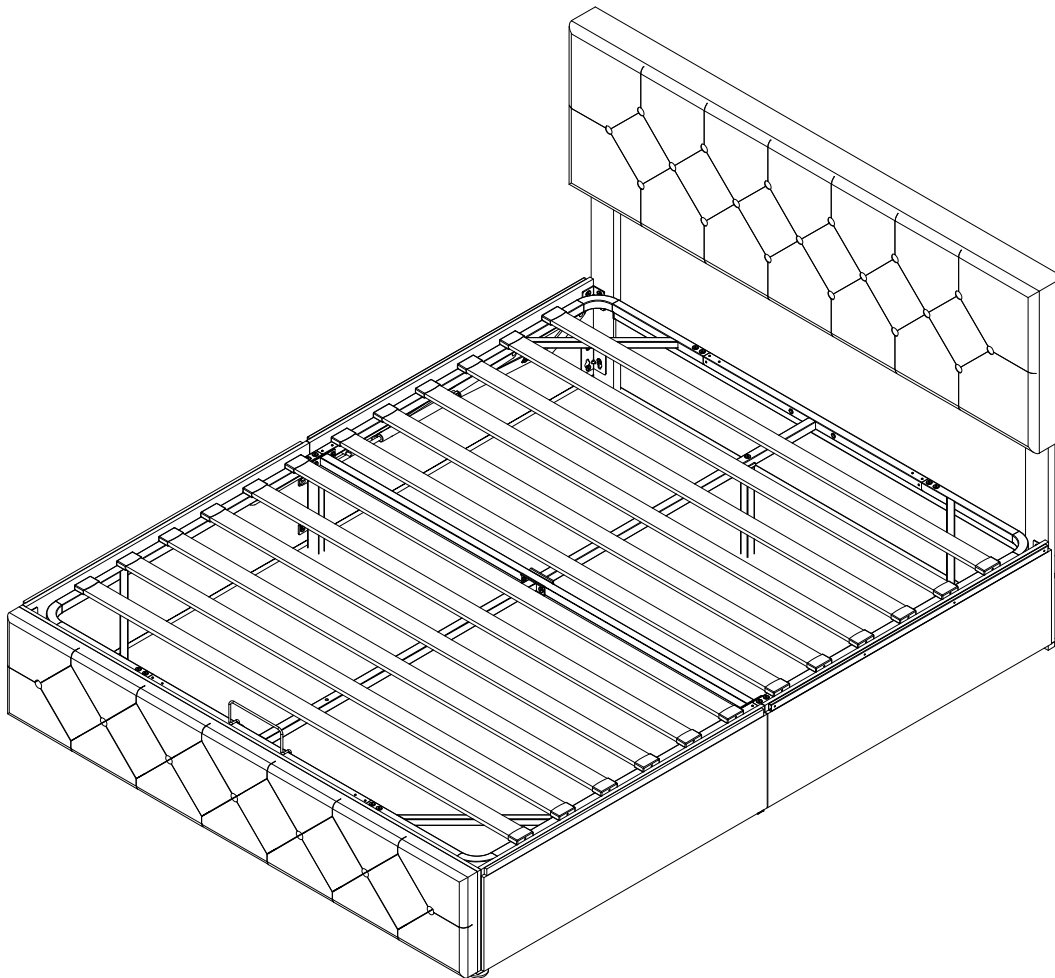

Freundlicher Kundenservice

Zufriedenheitsgarantien: Bei Problemen mit der Montage, der Qualität oder der Rückgabe können Sie sich gerne direkt an uns wenden.

Service client amical





Garanties de satisfaction : si vous rencontrez des problèmes d'assemblage, de qualité ou de retour, n'hésitez pas à nous contacter directement.

Friendly customer Service

Satisfaction guarantee: if you have any problems with assembly, quality or feedback, please feel free to contact us directly.

IMPORTANT/WICHTIG/ATENCION

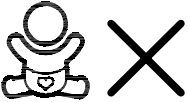
IMPORTANT/IMPORTANTE

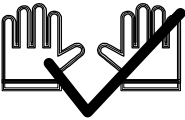



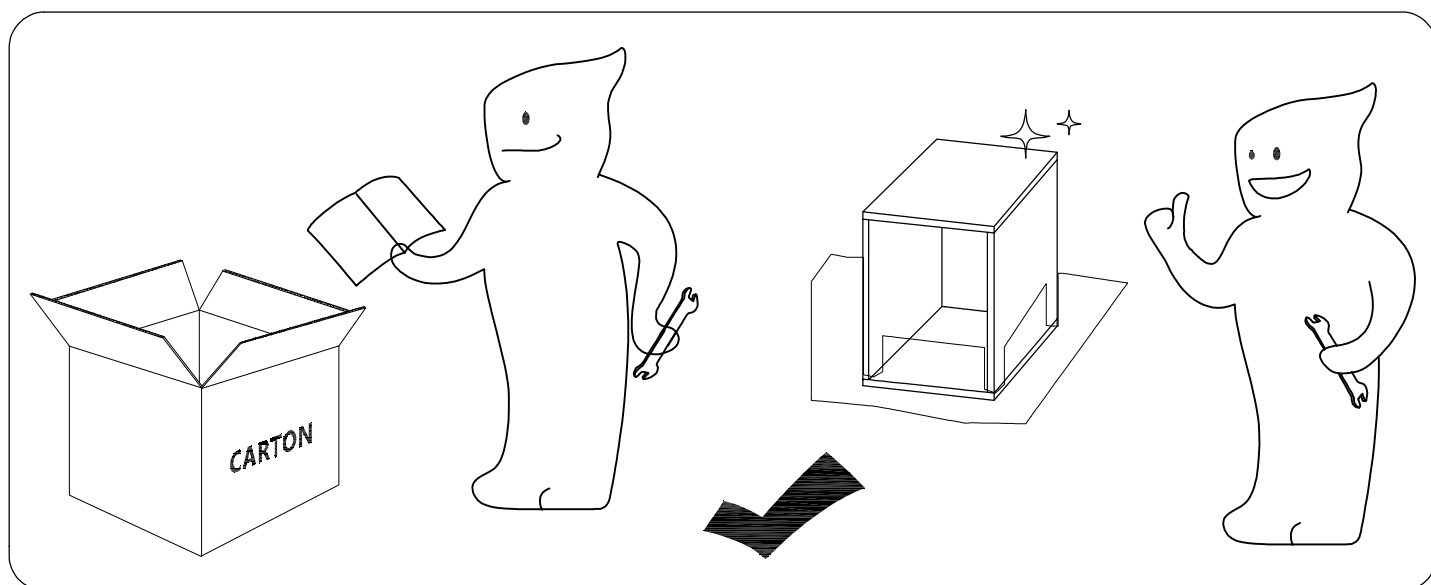
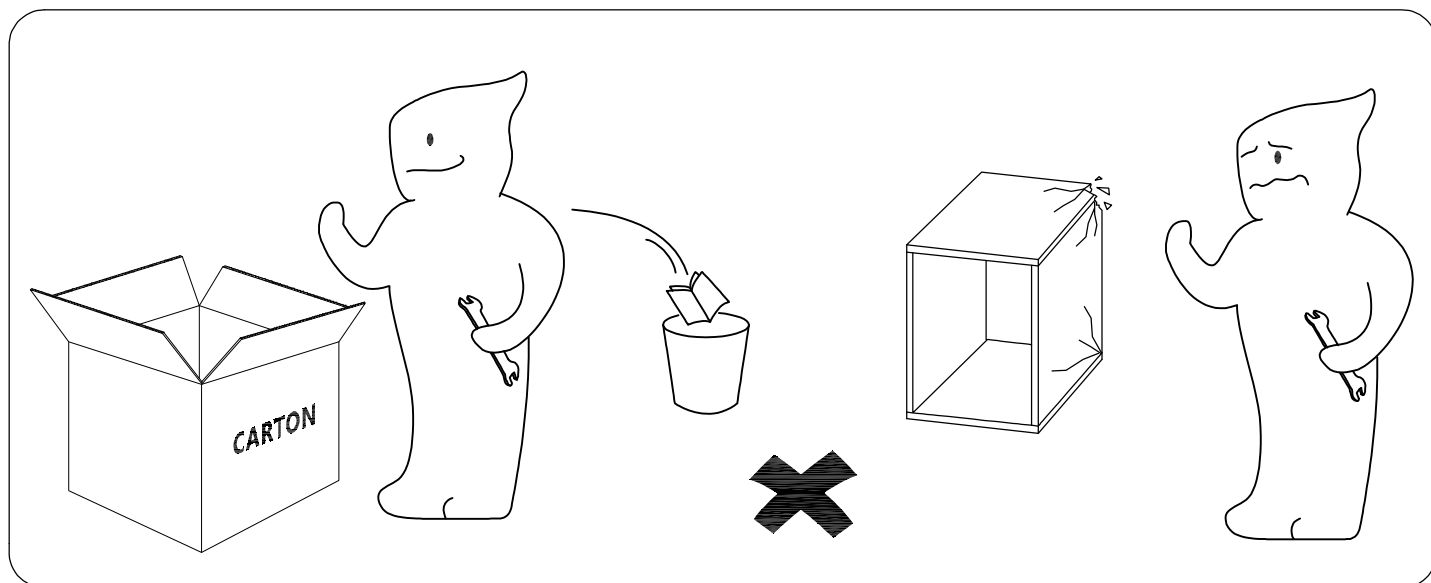

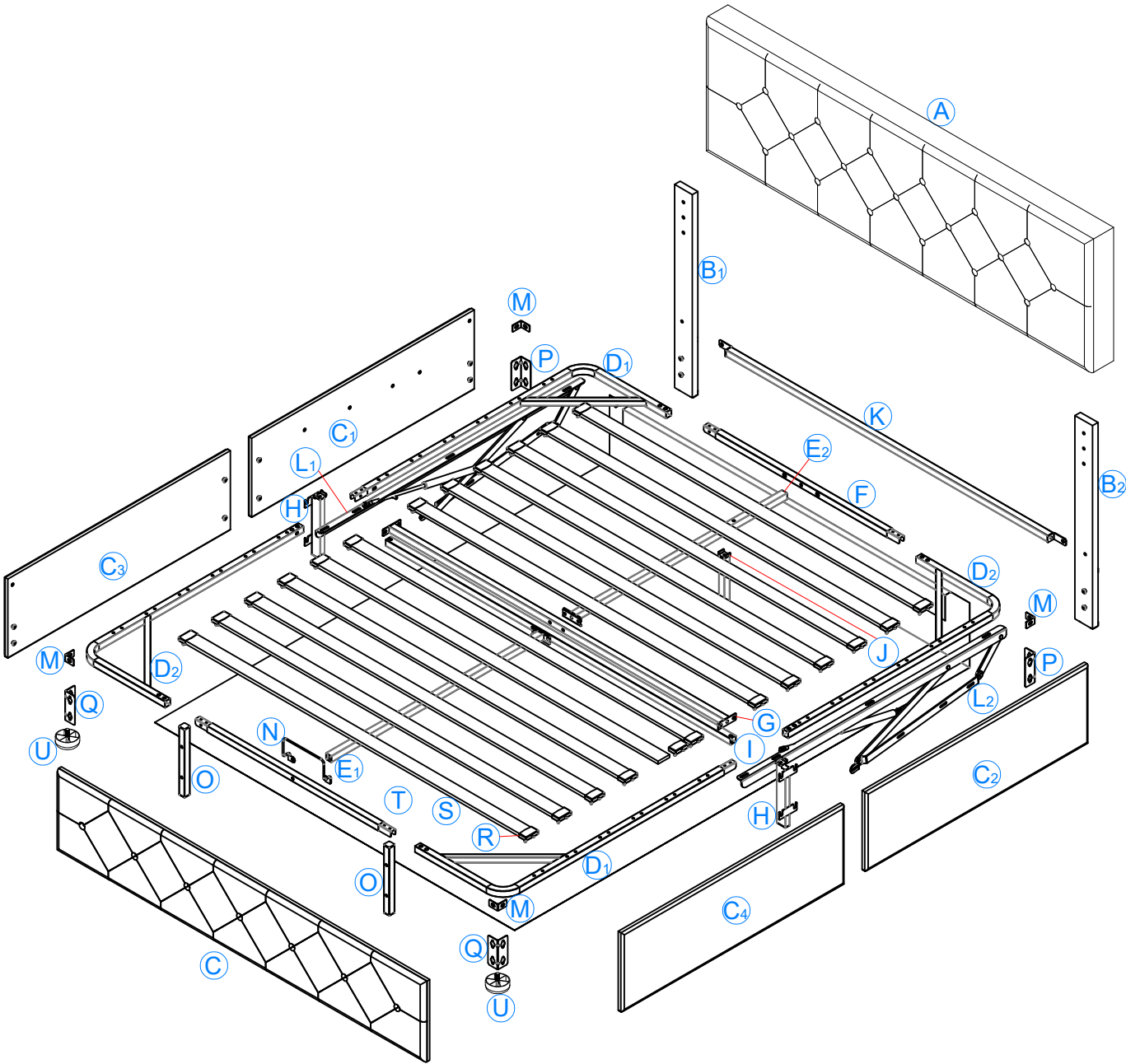

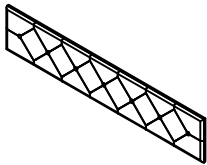
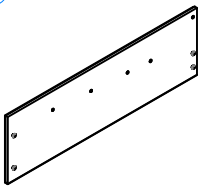
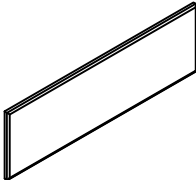
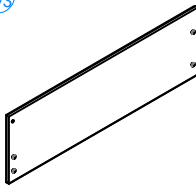
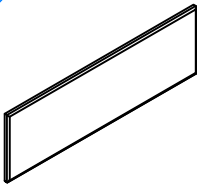

	<p>EN-We recommend 2 or more people to install. DE-Wir empfehlen, dass die Montage von 2 oder mehreren Personen durchgeführt werden sollte. ES-Recomendamos realizar el ensamble con 2 o más personas. FR -Il est recommandé d'effectuer le montage à 2 personne(s) ou plus. IT -È necessaria la presenza di 2 o più persone per il montaggio di questo prodotto.</p>
	<p>EN-The expected assembly time is 1 h. DE-Die Montagezeit beträgt durchschnittlich 1 h. ES-El tiempo aproximado de ensamble es de 1 h. FR-Le temps nécessaire est estimé à 1 h. IT-Il tempo previsto per il corretto assemblaggio è di 1 h.</p>
	<p>EN-Not intended for use by children. DE-Nicht geeignet für Kinder. ES-Producto no apto para niños. FR -Produit non destiné à être utilisé par des enfants. IT - Questo prodotto non è destinato all'uso da parte dei bambini.</p>
	<p>EN-Keep away from fire or other heat sources. DE-Bitte von Feuer und Hitzequellen fernhalten. ES -Manténgase alejado de las llamas y otras fuentes de calor. FR -Tenir à distance des flammes et autres sources de chaleur. IT -Tenere lontano dal fuoco o da altre fonti di calore.</p>
	<p>EN-We recommend wearing protective gloves.DE-Wir empfehlen das Tragen von Schutzhandschuhen.ES-Recomendamos el uso de guantes de seguridad.FR-I est recommandé de porter des gants de protection.IT-Per il processo di assemblaggio, consigliamo fortemente l'utilizzo di guanti protettivi.</p>

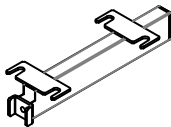
EN - Please follow the instruction manuals and use a pad to avoid damage during assembly.
DE - Bitte folgen Sie der Anleitung und verwenden Sie eine Unterlage, um Beschädigungen bei der Montage zu vermeiden.
ES - Por favor, siga las instrucciones del manual y utilice una cubierta o lona para proteger el producto y el suelo durante la instalación.
FR - Suivez les instructions de la notice et utilisez une couverture ou une bache pour protéger le produit et les sols pendant le montage.
IT - Si prega di consultare il manuale illustrativo durante il montaggio e di utilizzare un cuscinetto per evitare possibili danni.

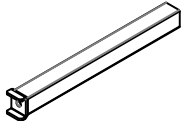
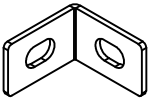
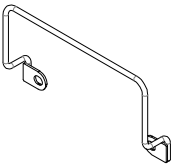
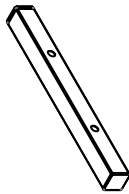
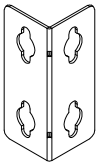
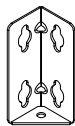
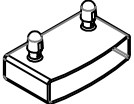
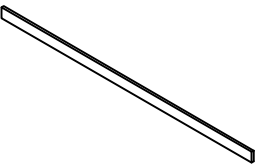
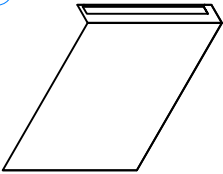

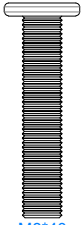

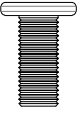

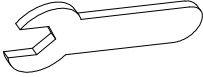

LISTE DER EINZELTEILE
 LISTE D'OBJETS
 PARTS LIST
 PAKET 1/FORFAIT 1/PACKAGE 1

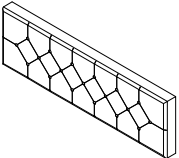

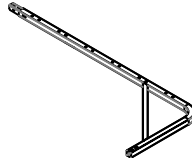
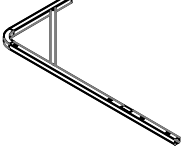
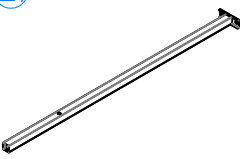
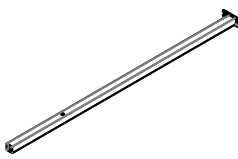
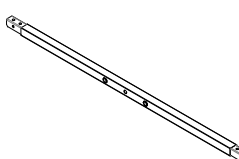
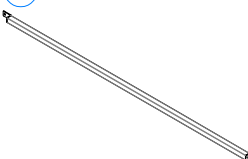
C  1PCS	C1  1PCS	C2  1PCS	C3  1PCS	C4  1PCS
G  1PCS	H  2PCS	I  1PCS	J  1PCS	M  4PCS
N  1PCS	O  2PCS	P  2PCS	Q  2PCS	R  24PCS
S  12PCS	T  1PCS	U  2PCS	1  M8*40 13PCS	2  M8*50 2PCS
3  M8*15 44PCS	5  4*80 1PCS	6  2PCS	7  1PCS	

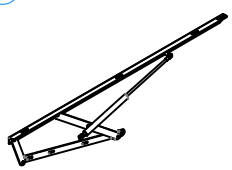
LISTE DER EINZELTEILE
 LISTE D'OBJETS
 PARTS LIST
 PAKET 2/FORFAIT 2/PACKAGE 2

<p>A</p>  <p>1PCS</p>	<p>B₁</p>  <p>1PCS</p>	<p>B₂</p>  <p>1PCS</p>	<p>D₁</p>  <p>2PCS</p>	<p>D₂</p>  <p>2PCS</p>
<p>E₁</p>  <p>1PCS</p>	<p>E₂</p>  <p>1PCS</p>	<p>F</p>  <p>2PCS</p>	<p>K</p> 	<p>L₁</p>  <p>1PCS</p>
<p>L₂</p>  <p>1PCS</p>				

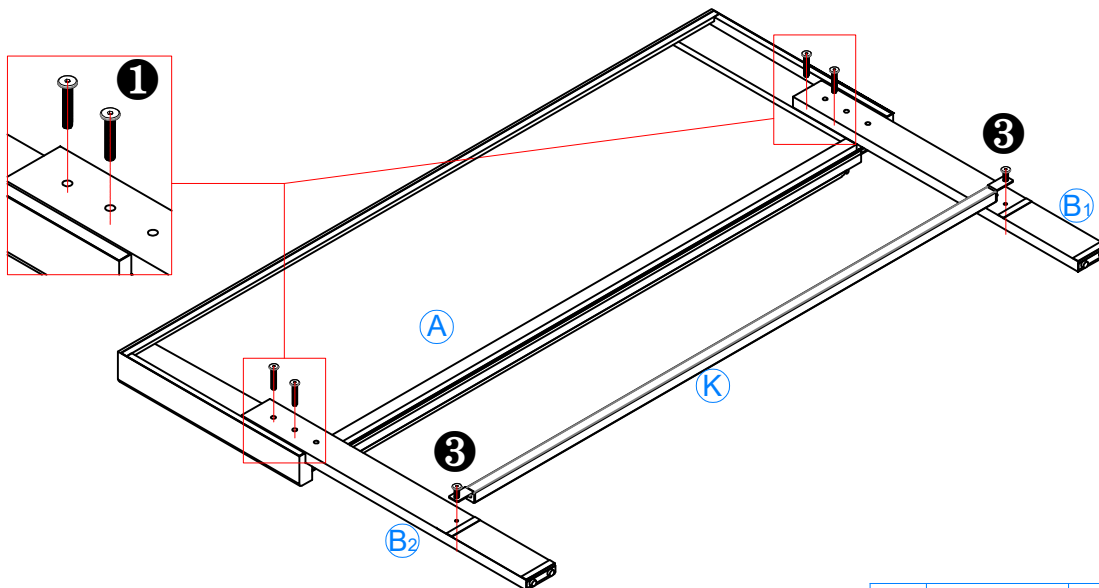
1



1		4PCS
3		2PCS

2

Schraube lösen, P/Q einhängen und wieder festziehen.
 Desserrez la vis, suspendez P/Q et resserrez.
 Loosen the screw first. Hanging P/Q on the screws.
 Tighten the screws.

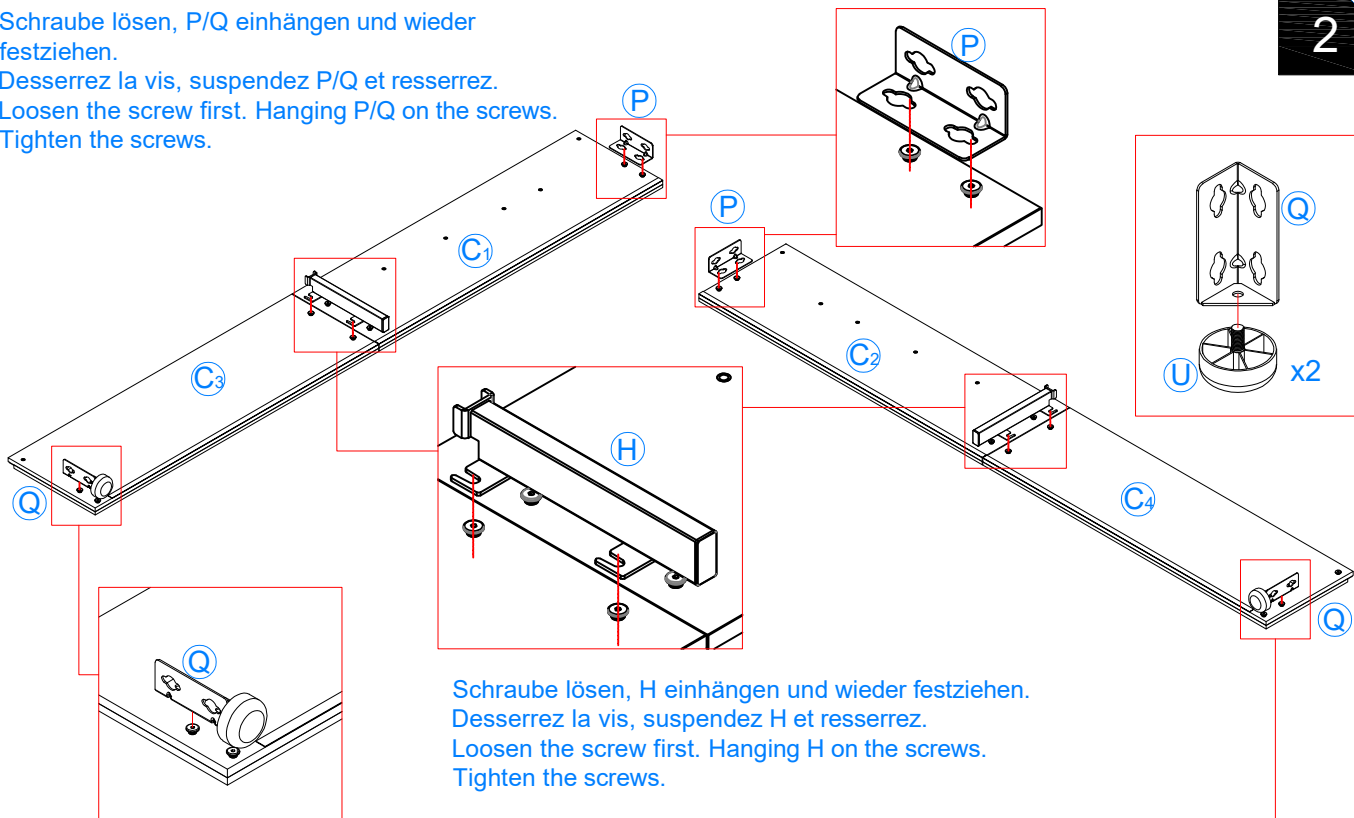

Schraube lösen, H einhängen und wieder festziehen.
 Desserrez la vis, suspendez H et resserrez.
 Loosen the screw first. Hanging H on the screws.
 Tighten the screws.

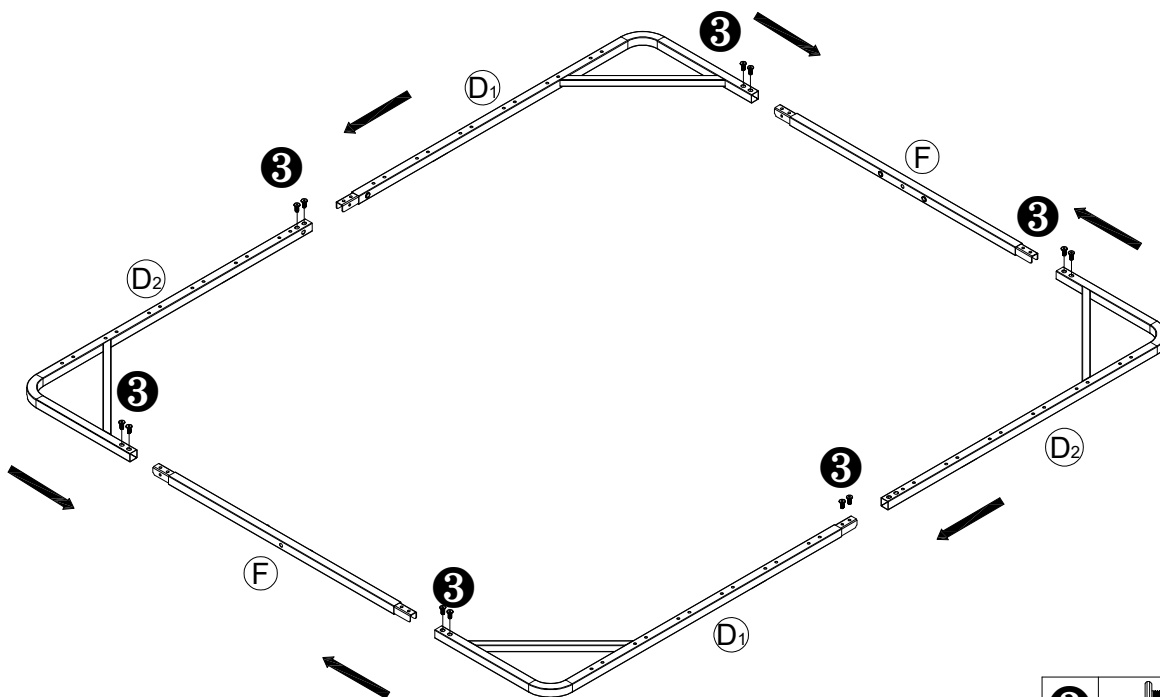

3

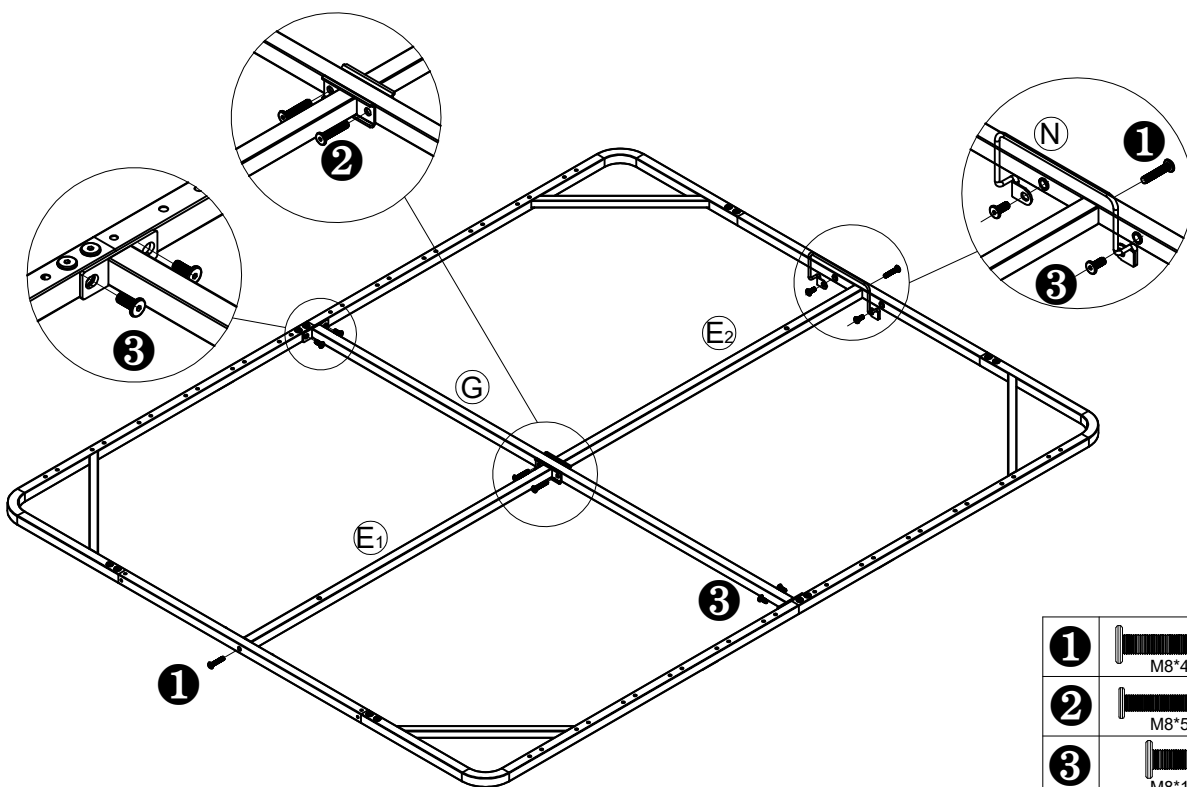

3		12PCS
	M8*15	

4



1		2PCS
	M8*40	
2		2PCS
	M8*50	
3		6PCS
	M8*15	

5

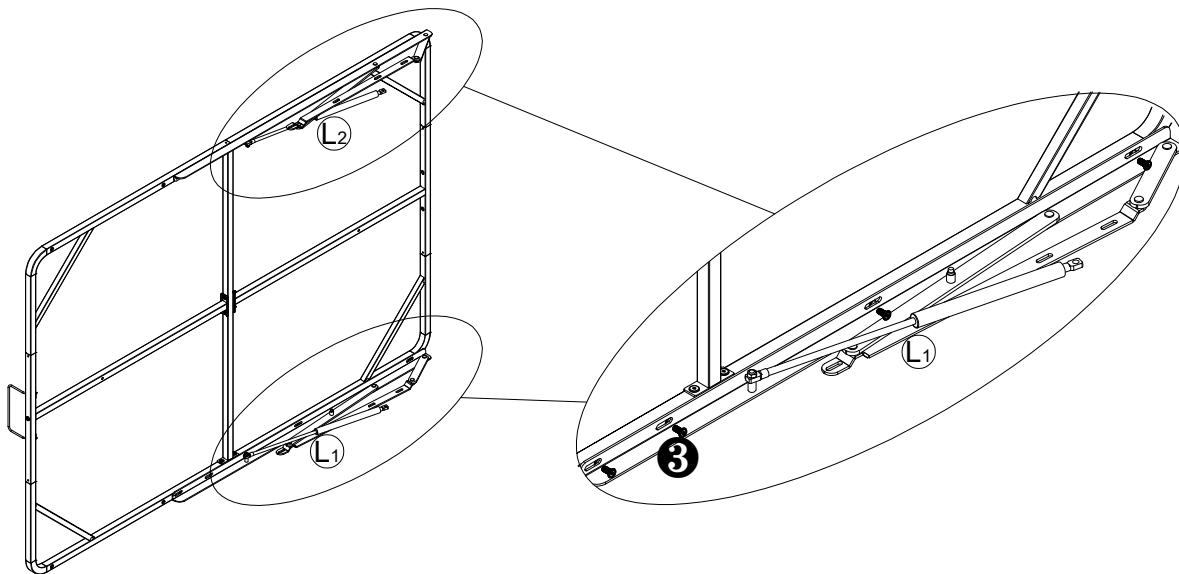

6

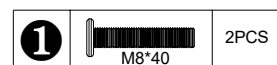
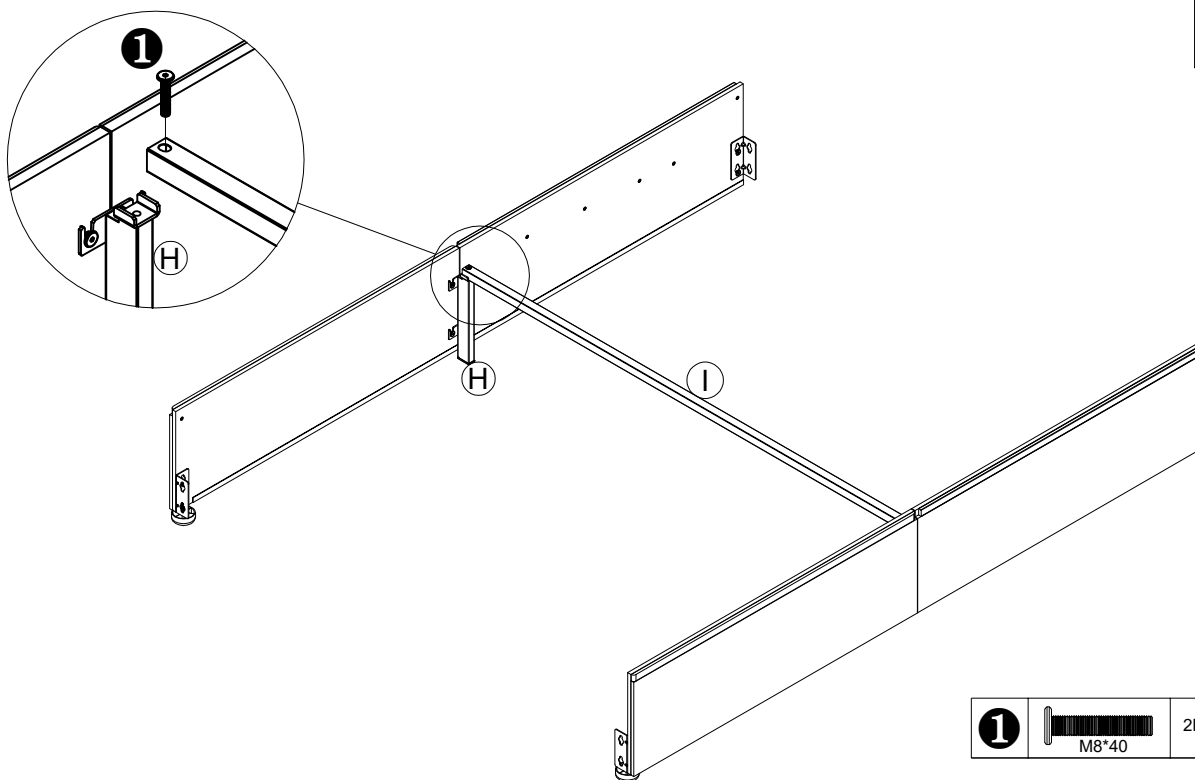

7

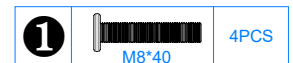
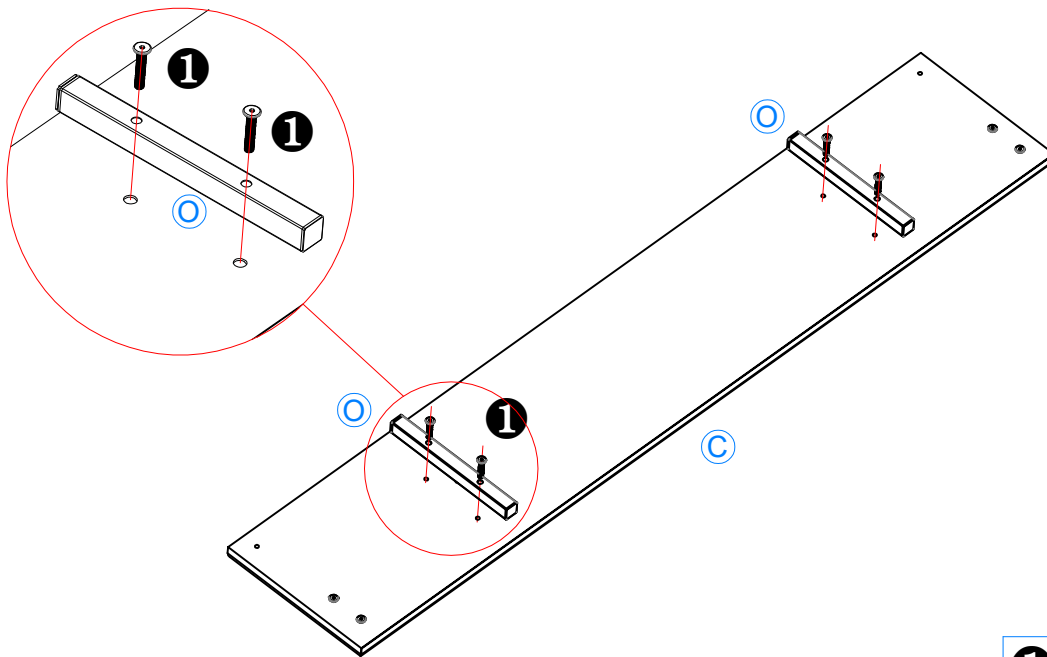

8

Schraube lösen, P/Q einhängen und wieder festziehen.
 Desserrez la vis, suspendez P/Q et resserrez.
 Loosen the screw first. Hanging P/Q on the screws.
 Tighten the screws.

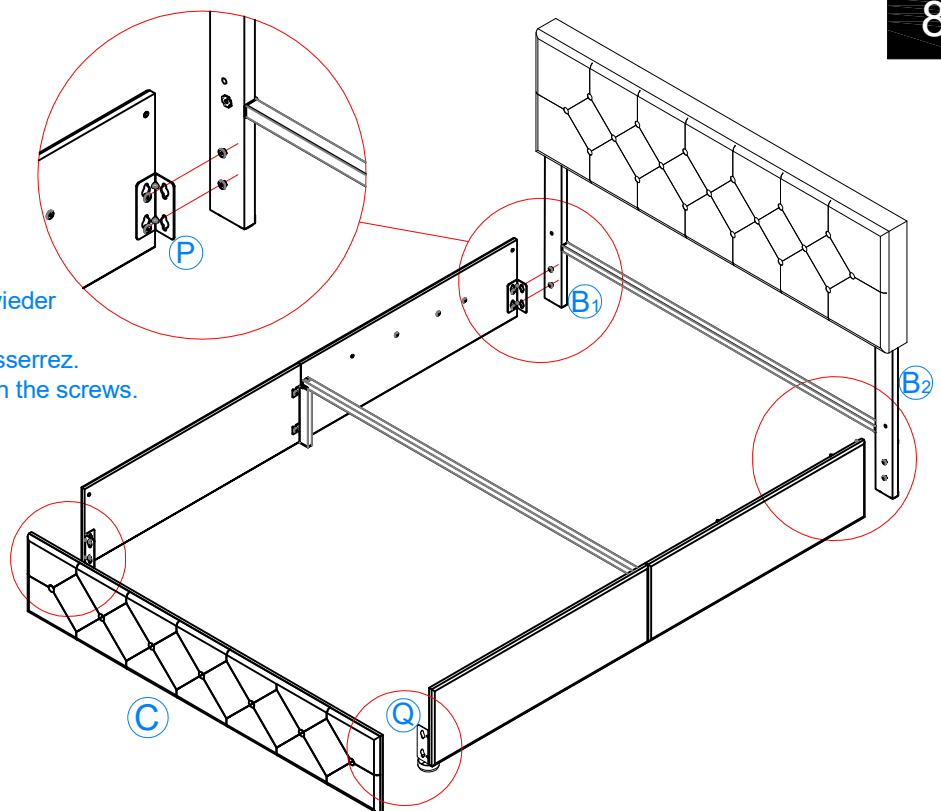

9

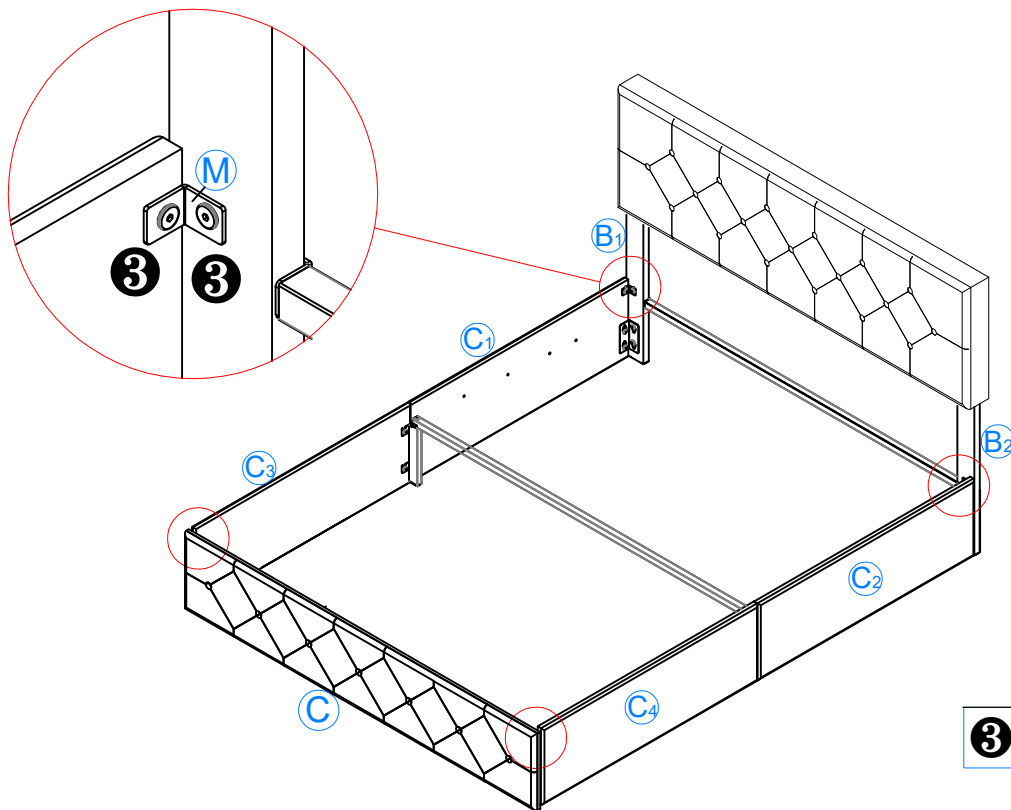

3 M8*15 8PCS

10

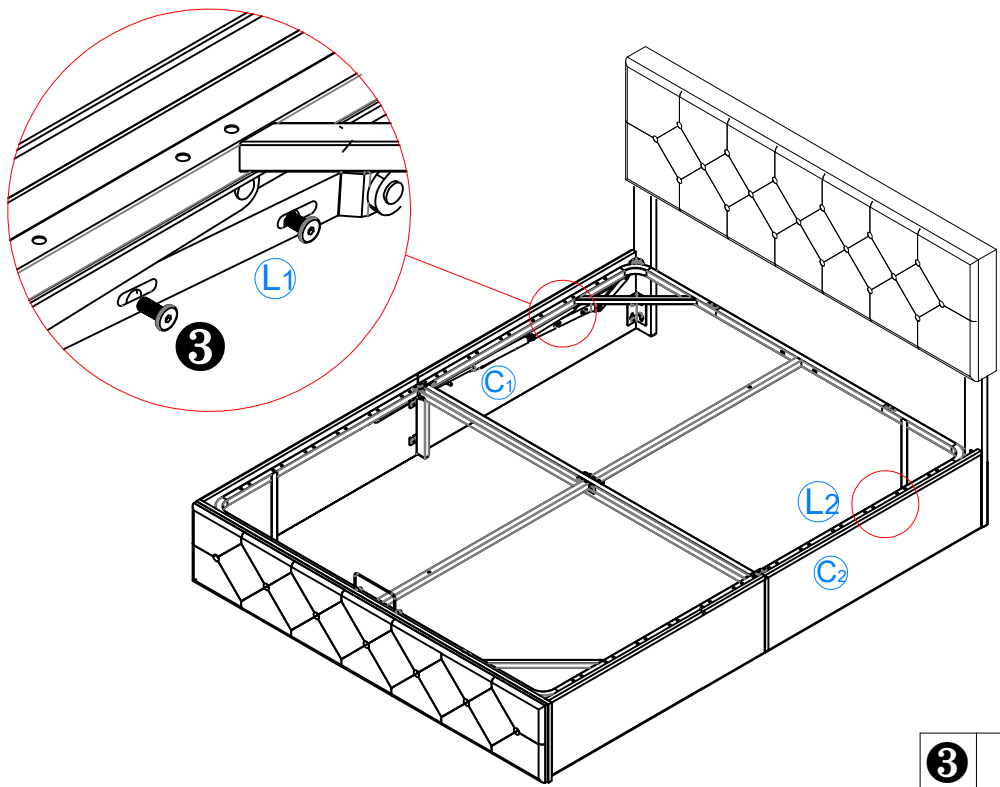

3 M8*15 8PCS

11

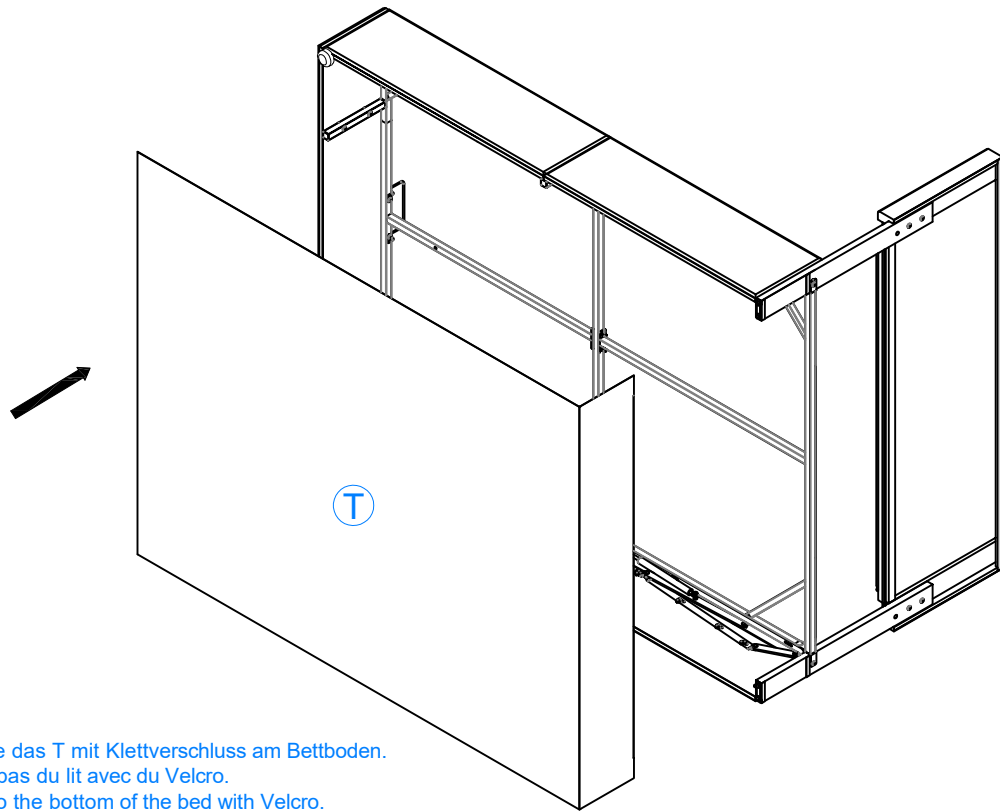

Befestigen Sie das T mit Klettverschluss am Bettboden.
Fixez le T au bas du lit avec du Velcro.
Attach the T to the bottom of the bed with Velcro.

12

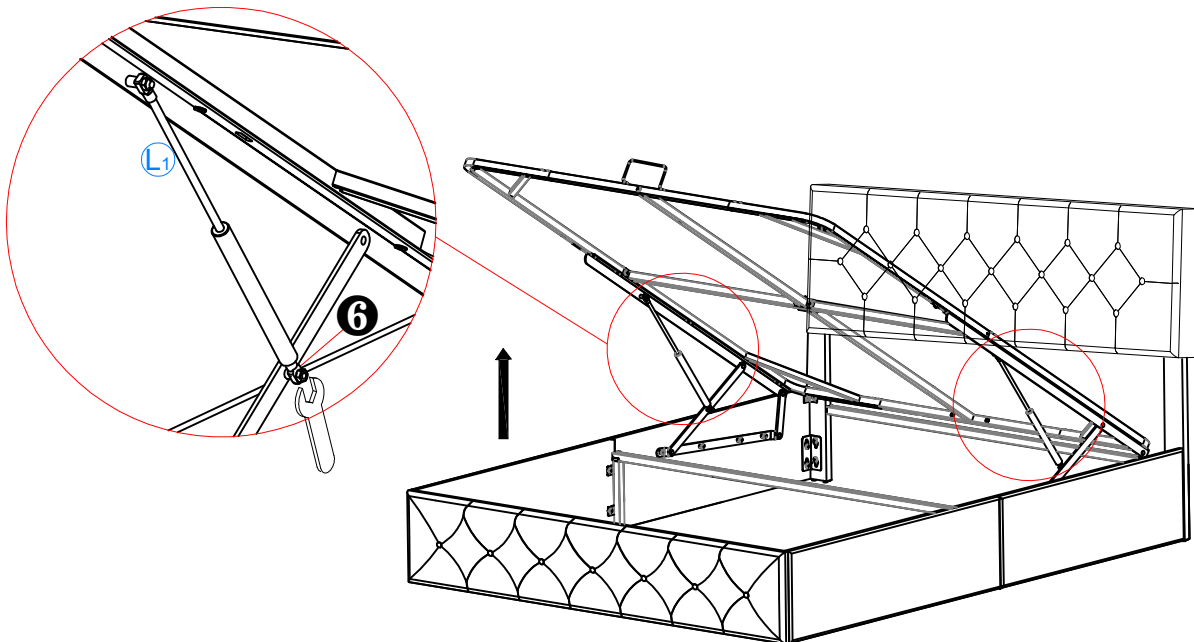

6  2PCS

13

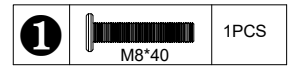
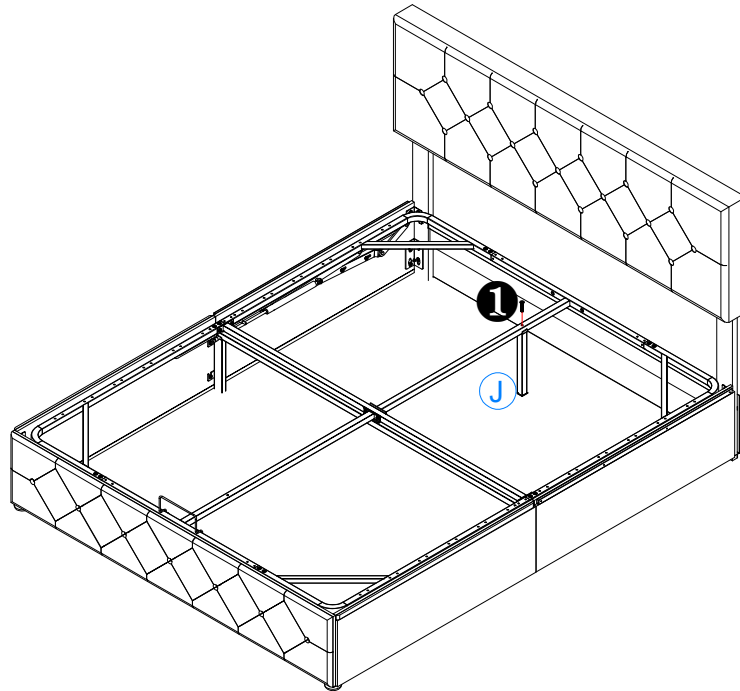

14

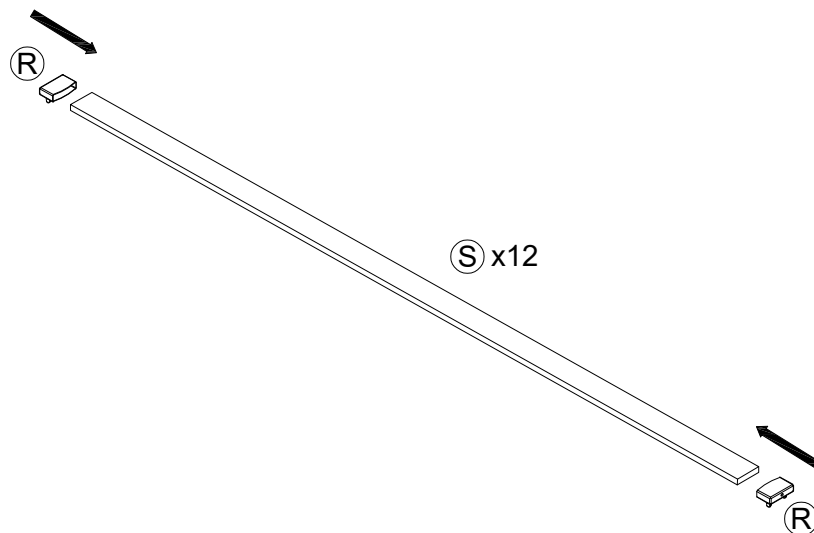

15

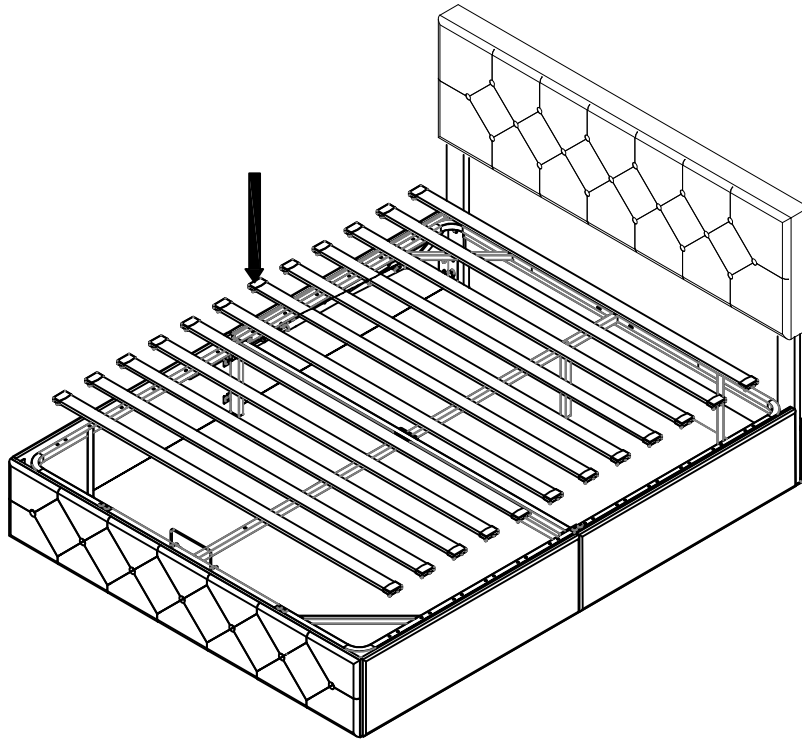

Finished Product
Fertiges Produkt
Produit Fini

