

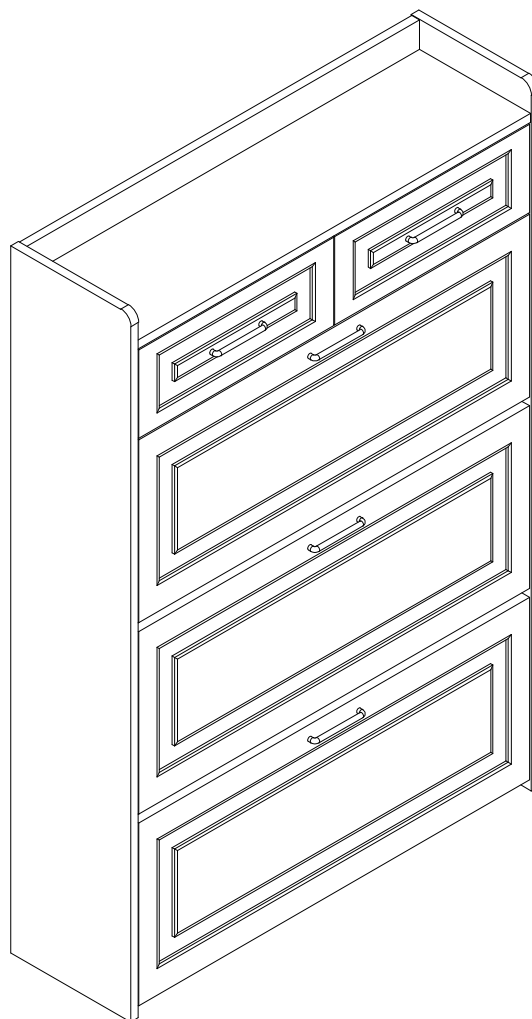



# BOX-1 WF319086AAA

# BOX-2 WF319087AAA

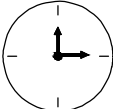
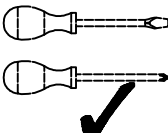

 2PERS	 55 MIN	Tool Required Not Provided		
				

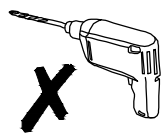

[DE]

Warnung: Lesen Sie die Anleitung vor dem Zusammenbau bitte vollständig durch. Überprüfen Sie, ob Sie alle auf den Seiten aufgeführten Komponenten und Werkzeuge haben.

Warnung: Legen Sie alle Teile auf eine ebene Fläche. Legen Sie eine weiche Decke oder Ähnliches darunter, um sie vor Kratzern oder Flecken zu schützen. Vermeiden Sie es, Komponenten über den Boden zu ziehen oder zu schieben.

Warnung: Überprüfen Sie regelmäßig alle Beschläge und Befestigungen, um sicherzustellen, dass sie sicher sind und um Unfälle zu vermeiden. Wenn Teile fehlen, kaputt, beschädigt oder abgenutzt sind, verwenden Sie das Produkt nicht weiter, bis es mit vom Hersteller autorisierten Teilen repariert wurde.

Warnung: Lassen Sie Kinder nicht auf die Möbel klettern, da dies zum Umkippen und zu schweren Verletzungen führen kann. Bauen Sie die Möbel außerhalb der Reichweite von Kindern zusammen.

Warnung: Stellen Sie die Möbel nicht in die Nähe von Feuerquellen oder heißen Gegenständen, um Brandgefahr zu vermeiden.

Warnung: Reinigen Sie die Möbel mit einem feuchten Tuch oder Alkohol. Verwenden Sie keine Reinigungsmittel mit ätzenden Chemikalien.

Warnung: Dieses Produkt ist mit einer Kippschutzvorrichtung ausgestattet. Bitte installieren Sie diese Vorrichtung unbedingt, um unnötige Verletzungen durch Umkippen zu vermeiden.

[EN]

Warning: Please read instructions fully before starting assembly. Check you have all the components and tools listed on pages.

Warning: Please place all parts on a flat surface. Place a soft blanket or similar underneath to protect against scratches or stains. Avoid dragging or sliding components across the floor.

Warning: Regularly check all fittings and fastenings to ensure they are secure and to prevent accidents. If any parts are missing, broken, damaged, or worn, discontinue use of the product until repairs have been made using factory authorized parts.

Warning: Do not allow children to climb on the furniture as this may result in tipping and serious personal injury. Assemble the furniture away from the reach of children.

Warning: Do not place furniture close to fire sources or high-temperature objects to avoid the risk of fire.

Warning: Clean furniture with a damp cloth or alcohol, avoid using cleaning agents containing corrosive chemicals.

Warning: This product is equipped with an anti-tilt device. Please be sure to install this device to prevent unnecessary injuries caused by tipping.

[FR]

Avertissement : Veuillez lire entièrement les instructions avant de commencer l'assemblage.

Vérifiez que vous disposez de tous les composants et outils répertoriés sur les pages.

Avertissement : Veuillez placer toutes les pièces sur une surface plane. Placez une couverture douce ou similaire en dessous pour les protéger des rayures ou des taches. Évitez de faire glisser les composants sur le sol.

Avertissement : Vérifiez régulièrement tous les raccords et fixations pour vous assurer qu'ils sont bien fixés et pour éviter les accidents. Si des pièces manquent, sont cassées, endommagées ou usées, cessez d'utiliser le produit jusqu'à ce que des réparations aient été effectuées à l'aide de pièces autorisées par l'usine.

Avertissement : Ne laissez pas les enfants grimper sur les meubles car cela pourrait entraîner un basculement et des blessures graves. Assemblez les meubles hors de portée des enfants.

Avertissement : Ne placez pas les meubles à proximité de sources de feu ou d'objets à haute température pour éviter tout risque d'incendie.



Avertissement : Nettoyez les meubles avec un chiffon humide ou de l'alcool, évitez d'utiliser des produits de nettoyage contenant des produits chimiques corrosifs.

Avertissement : Ce produit est équipé d'un dispositif anti-basculement. Assurez-vous d'installer ce dispositif pour éviter les blessures inutiles causées par un basculement.

[IT]

Attenzione: leggere attentamente le istruzioni prima di iniziare il montaggio. Verificare di avere tutti i componenti e gli strumenti elencati nelle pagine.

Attenzione: posizionare tutte le parti su una superficie piana. Posizionare una coperta morbida o simile sotto per proteggere da graffi o macchie. Evitare di trascinare o far scivolare i componenti sul pavimento.

Attenzione: controllare regolarmente tutti i raccordi e i dispositivi di fissaggio per assicurarsi che siano sicuri e per prevenire incidenti. Se alcune parti sono mancanti, rotte, danneggiate o usurate, interrompere l'uso del prodotto fino a quando non siano state eseguite le riparazioni utilizzando parti autorizzate dalla fabbrica.

Attenzione: non consentire ai bambini di arrampicarsi sui mobili poiché ciò potrebbe causare ribaltamenti e gravi lesioni personali. Montare i mobili lontano dalla portata dei bambini.

Attenzione: non posizionare i mobili vicino a fonti di fuoco o oggetti ad alta temperatura per evitare il rischio di incendio.

Attenzione: pulire i mobili con un panno umido o alcol, evitare di utilizzare detergenti contenenti sostanze chimiche corrosive.

Attenzione: questo prodotto è dotato di un dispositivo antiribaltamento. Assicurarsi di installare questo dispositivo per prevenire lesioni inutili causate dal ribaltamento.

[ES]

Advertencia: Lea las instrucciones completamente antes de comenzar el montaje. Compruebe que tiene todos los componentes y herramientas que se enumeran en las páginas.

Advertencia: Coloque todas las piezas sobre una superficie plana. Coloque una manta suave o algo similar debajo para protegerlas de rayones o manchas. Evite arrastrar o deslizar los componentes por el piso.

Advertencia: Verifique regularmente todos los accesorios y fijaciones para asegurarse de que estén seguros y evitar accidentes. Si falta alguna pieza, está rota, dañada o desgastada, deje de usar el producto hasta que se hayan realizado las reparaciones con piezas autorizadas de fábrica.

Advertencia: No permita que los niños se suban a los muebles, ya que esto puede provocar que se vuelquen y lesiones personales graves. Monte los muebles fuera del alcance de los niños.

Advertencia: No coloque los muebles cerca de fuentes de fuego u objetos de alta temperatura para evitar el riesgo de incendio.

Advertencia: Limpie los muebles con un paño húmedo o alcohol, evite usar agentes de limpieza que contengan químicos corrosivos.

Advertencia: Este producto está equipado con un dispositivo antivuelco. Asegúrese de instalar este dispositivo para evitar lesiones innecesarias causadas por vuelcos.

<b>Importeur</b>	Decobus Handel GmbH		
<b>Adresse</b>	Innungsstraße 9, 21244 Buchholz, Deutschland		
<b>URL</b>	<a href="https://www.decobusgroup.de">https://www.decobusgroup.de</a>		
<b>Hersteller</b>	Shouguang Rema Wood Co.,LTD		
<b>Adresse</b>	Daotian Town, Shouguang City,Weifang,Shandong,China		
<b>Email/URL</b>	<a href="https://www.remawood.com">https://www.remawood.com</a>		
<table border="1"><tr><td><b>EC</b></td><td><b>REP</b></td></tr></table>	<b>EC</b>	<b>REP</b>	Decobus Handel GmbH Innungsstraße 9, 21244 Buchholz, Deutschland <a href="https://www.decobusgroup.de">https://www.decobusgroup.de</a>
<b>EC</b>	<b>REP</b>		

**EN**

**Dear customer,**

Thank you for purchasing this product. So that your appliance serves you well, please read all the instructions in this user's manual. If you have any questions, please contact our customer care center.

**FR**

**Cher client,**

Nous vous remercions d'avoir acheté ce produit. Afin que vous puissiez profiter pleinement de votre appareil, veuillez lire toutes les instructions de ce manuel d'utilisation. Si vous avez la moindre question, veuillez contacter notre centre d'assistance à la clientèle.

**DE**

**Sehr geehrter Kunde,**

Vielen Dank, dass Sie dieses Produkt erworben haben. Damit Ihr Gerät Ihnen gute Dienste leistet, lesen Sie bitte alle Hinweise in diesem Benutzerhandbuch. Wenn Sie Fragen haben, wenden Sie sich bitte an unser Kundendienstzentrum.

**ES**

**Queridos clientes,**

Gracias por comprar este producto. Para que su electrodoméstico le sirva mejor, lea todas las instrucciones de este manual del usuario. Si tiene alguna pregunta, comuníquese con nuestro Centro de Atención al Cliente.

**IT**

**Caro Cliente,**

Grazie per aver acquistato questo prodotto. Per servirti meglio con questo apparecchio ti prego di leggere tutte le istruzioni in presente manuale utente. In caso di dubbio, si prega di contattare il nostro centro assistenza clienti.



Our product will be delivered to you in 2 packages. The delivery times of these 2 packages may differ, please be patient and thank you for your understanding.

Unser Produkt wird Ihnen in 2 Paketen geliefert. Die Lieferzeiten dieser 2 Pakete können abweichen, bitte haben Sie etwas Geduld und vielen Dank für Ihr Verständnis.

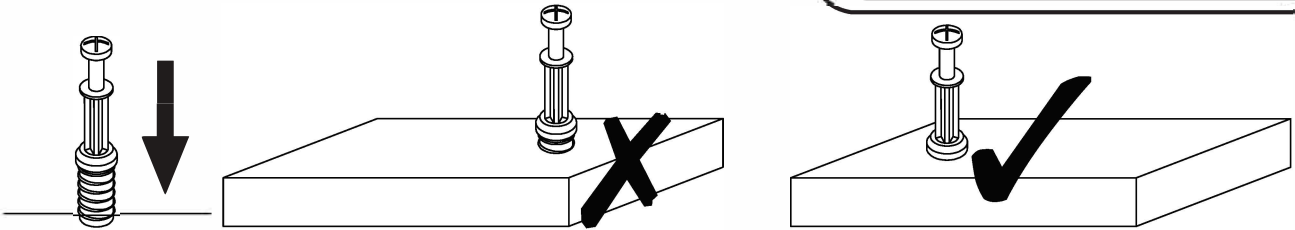

**EN\_QUICKFIT:** Tighten quickfit until shoulder is flush with panel. Do not overtighten or undertighten.

**FR\_RACCORD RAPIDE:** Faites serrer le raccord rapide jusqu'à ce que l'épaulement soit parfaitement encastré dans le panneau. Il ne faut ni trop serrer ni insuffisamment serrer.

**ES\_QUICKFIT:** Apriete quickfit hasta que el hombro se descargue con el panel. NO lo sobreapriete ni lo apriete poco.

**DE\_QUICKFIT:** Ziehen Sie den Quickfit fest, bis die Schulter mit der Platte bündig ist. Bitte nicht zu fest oder zu schwach anziehen.

**IT\_MONTAGGIO RAPIDO:** Stringere il montaggio rapido fino a quando la spalla è a filo con il pannello, non stringere troppo o troppo poco.

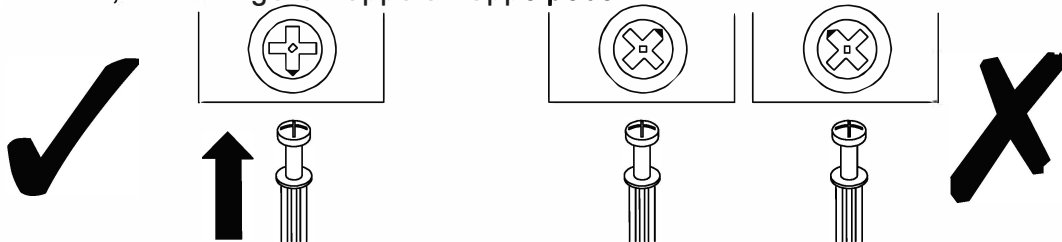

**EN\_CAM LOCK:** When fitting cam lock, ensure starting position is correct before you insert connecting quickfit.

**FR\_SERRURE BATTEUSE:** Avant d'insérer la serrure batteuse, veillez à la bonne orientation avant d'insérer le raccord rapide.

**ES\_CIERRE DE LA CÁMARA:** Cuando instale el cierre de la cámara, asegúrese de que la posición de inicio es correcta antes de que inserte el quickfit conector.

**DE\_CAM-LOCK:** Achten Sie bei der Montage des Cam-Locks auf die richtige Ausgangsposition, bevor Sie den Quickfit einsetzen.

**IT\_BLOCCAGGIO A CAMMA:** Quando si monta il bloccaggio a camma, assicurarsi che la posizione iniziale sia corretta prima di inserire il montaggio rapido di collegamento.

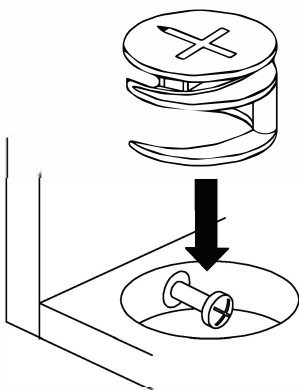

**EN\_Quickfit head** should be in the centre of the cam lock when the two panels are joined.

Cam lock should be inserted before quickfit.

**FR\_**Lorsque les deux panneaux sont assemblés, la tête du raccord rapide doit reposer au centre de la serrure batteuse.

Il faut insérer la serrure batteuse avant le raccord rapide.

**ES\_**El cabezal del quickfit debe estar en el centro del cierre de la cámara cuando se unan los dos paneles.

Se debe insertar el cierre de la cámara antes que el quickfit.

**DE\_**Der Quickfit-Kopf sollte sich in der Mitte des Cam-Locks befinden, wenn die beiden Platten zusammengefügt sind.

Der Cam-Lock sollte vor dem Quickfit eingesetzt werden.

**IT\_**La testa del montaggio rapido deve trovarsi al centro del bloccaggio a camma quando i due pannelli sono uniti.

Il Bloccaggio a Camma deve essere inserito prima del montaggio rapido.

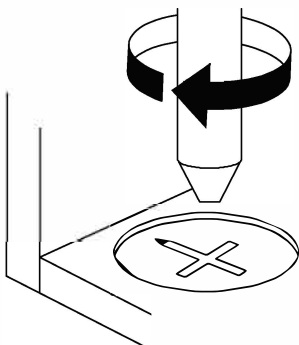

**EN\_**Turn cam lock clockwise to tighten.

**FR\_**Faites tourner la serrure batteuse dans le sens des aiguilles d'une montre pour la resserrer.

**ES\_**Gire el cierre de la cámara en sentido horario para apretarlo.

**DE\_**Drehen Sie den Cam-Lock im Uhrzeigersinn, um ihn festzuziehen.

**IT\_**Ruotare il bloccaggio a camma in senso orario per stringere.

WF319086AAA

6

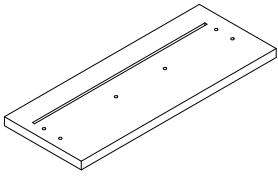

1

7

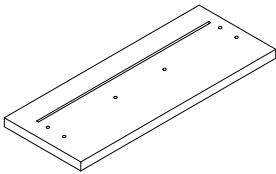

1

8

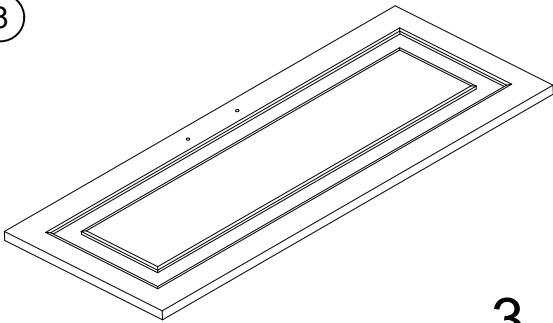

3

12

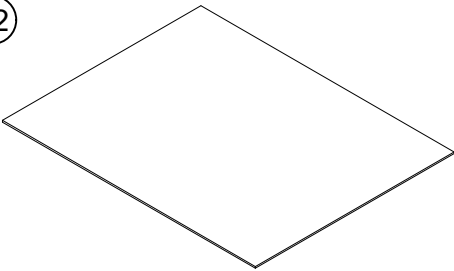

4

13

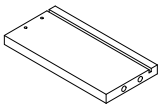

2

14

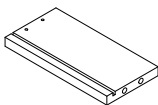

2

WF319087AAA

1

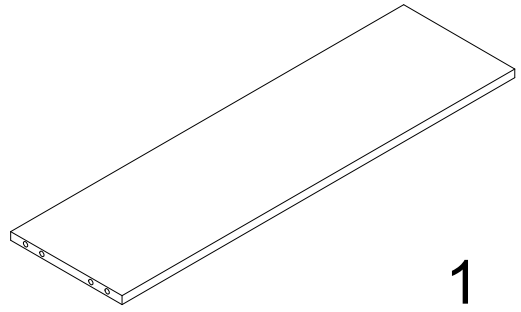

1

2

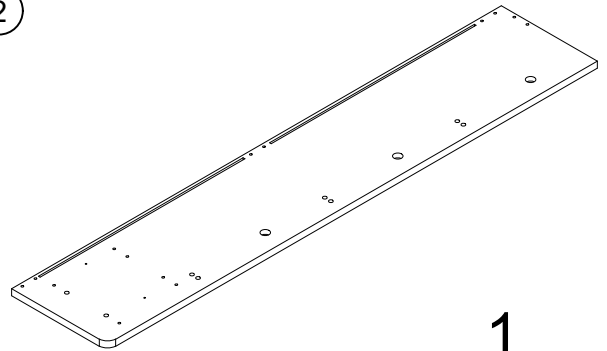

1

3

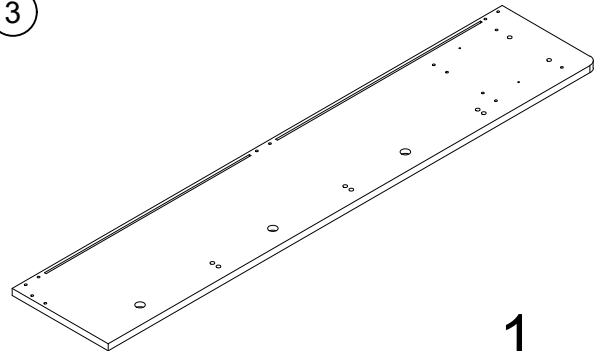

1

4

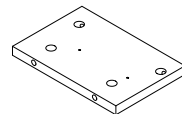

1

5

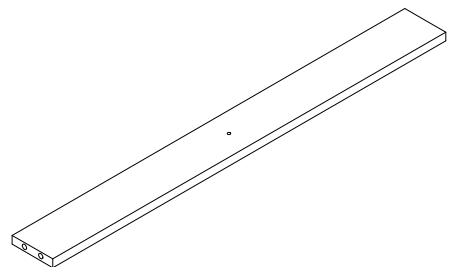

2

WF319086AAA

15

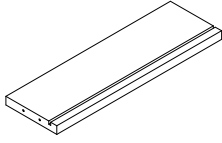

2

17

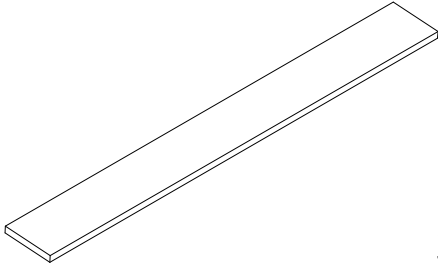

3

18

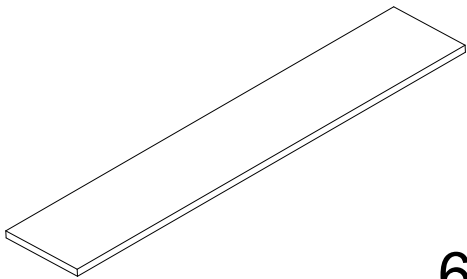

6

WF319087AAA

9

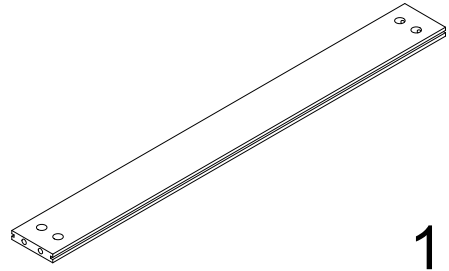

1

10

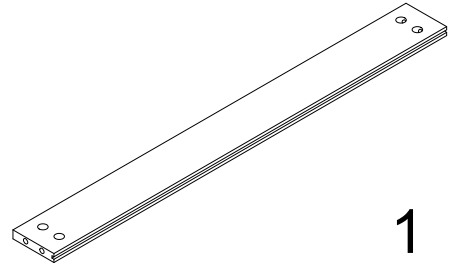

1

11

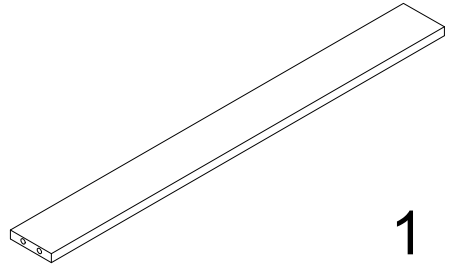

1

16

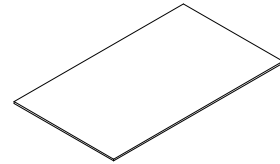

2

19

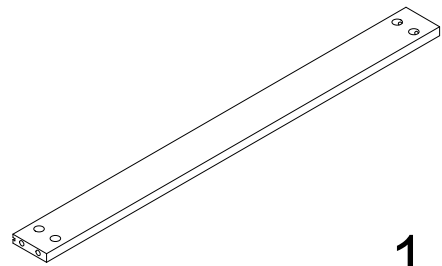



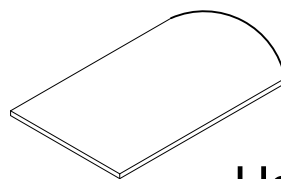



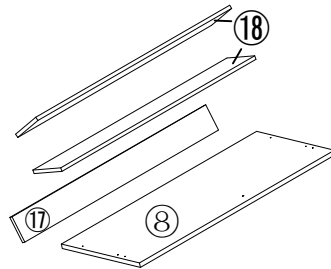
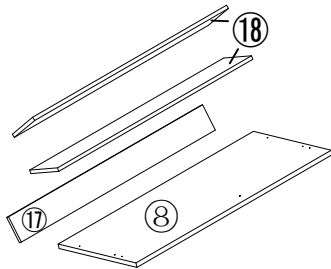
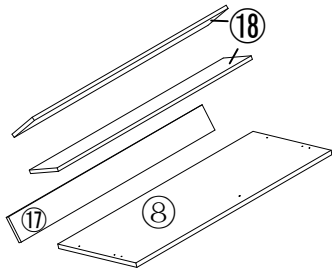
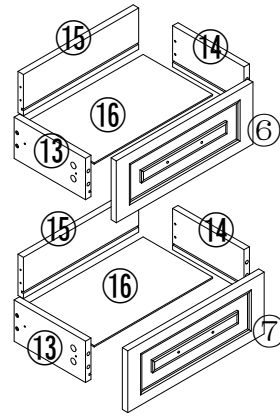
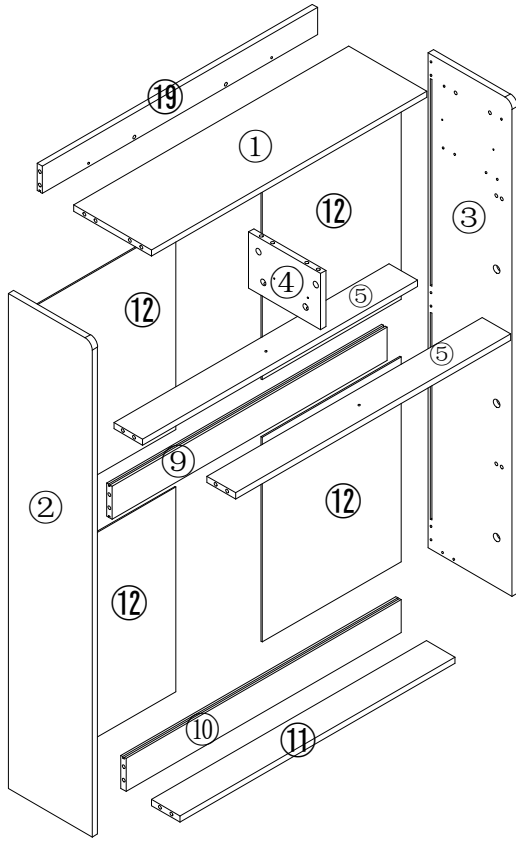



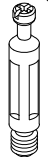

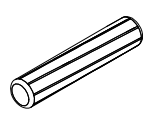
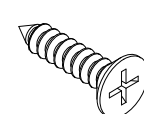

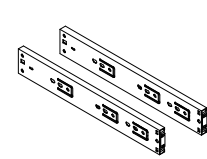
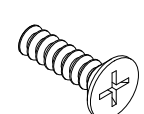
1

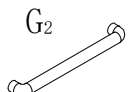
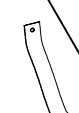

Hardware kit

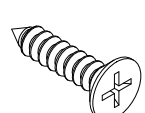

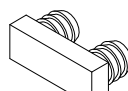
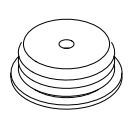
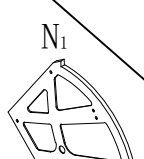
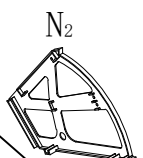
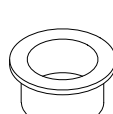
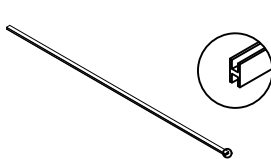

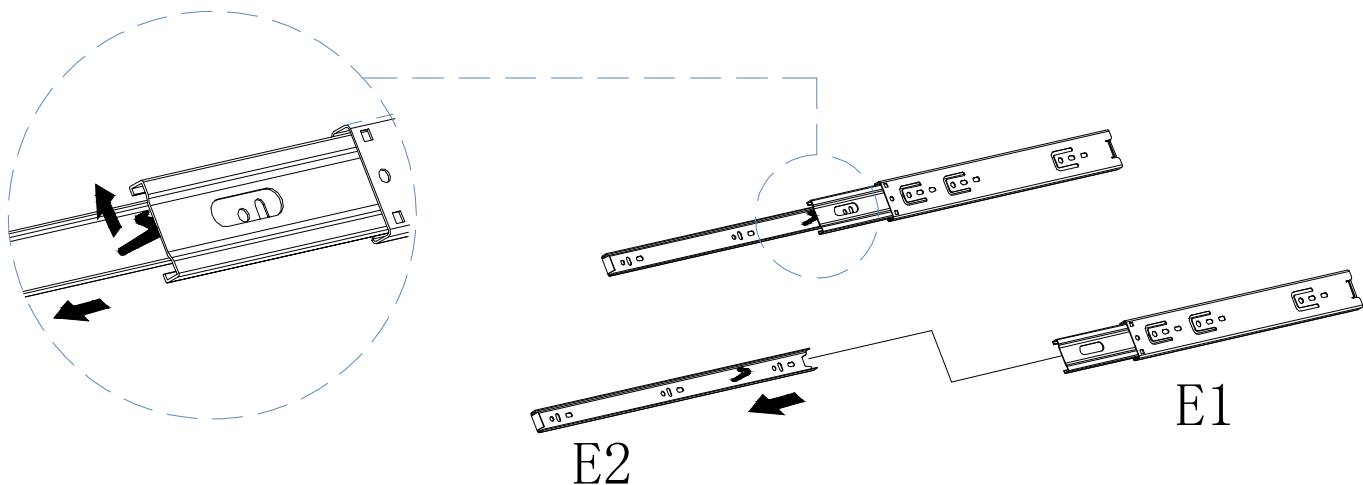

<p><b>A<sub>1</sub></b> Ø15*11.5 42PCS</p>  <p><b>A<sub>2</sub></b></p>  <p>Ø6*40 42PCS</p>	<p><b>B</b></p>  <p>Ø8*40 8PCS</p>	<p><b>C</b></p>  <p>M3.5*14 46PCS</p>	<p><b>D</b></p>  <p>M3.5*35 8PCS</p>
<p><b>E</b></p>  <p>L=200mm 4PCS</p>	<p><b>F</b></p>  <p>M4*12 6PCS</p>	<p><b>G<sub>1</sub></b></p>  <p><b>G<sub>2</sub></b></p>  <p>5PCS</p> <p>10PCS</p>	<p><b>H<sub>1</sub></b></p>  <p>2PCS</p> <p><b>H<sub>2</sub></b></p>  <p>2PCS</p> <p><b>H<sub>3</sub></b></p>  <p>2PCS</p> <p><b>H<sub>4</sub></b></p>  <p>2PCS</p>
<p><b>I</b></p>  <p>M3.5*16 18PCS</p>	<p><b>J</b></p>  <p>12PCS</p>	<p><b>L</b></p>  <p>6PCS</p>	<p><b>M</b></p>  <p>6PCS</p>
<p><b>N<sub>1</sub></b></p>  <p>3PCS</p> <p><b>N<sub>2</sub></b></p>  <p>3PCS</p>	<p><b>O</b></p>  <p>6PCS</p>	<p><b>P</b></p>  <p>2PCS</p>	<p><b>S</b></p>  <p>42PCS</p>

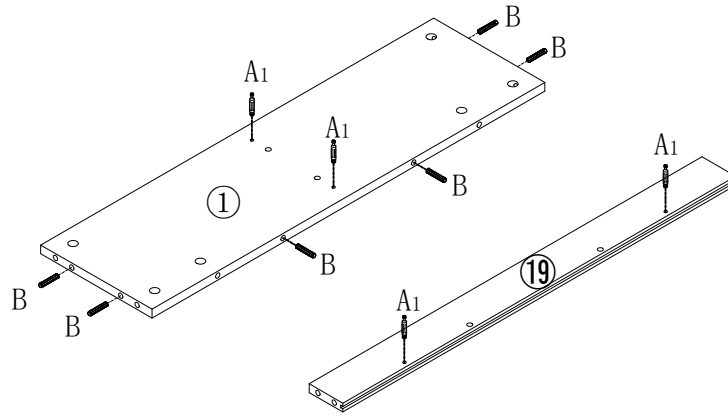

# Schritt 1

## Step 1



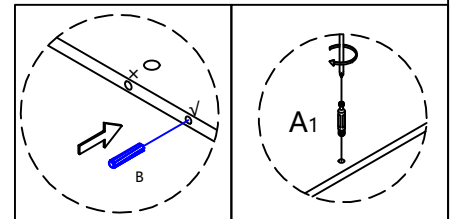

	A <sub>1</sub> x4pcs
	Bx6pcs

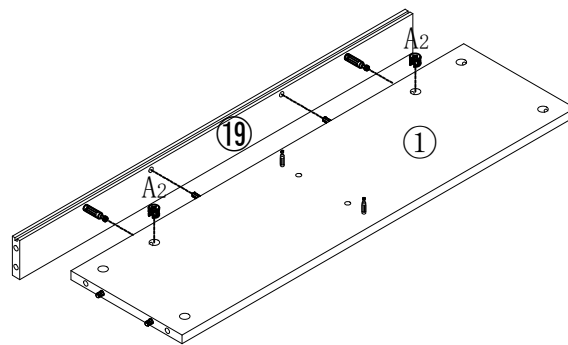

# Schritt 2

## Step 2



	A <sub>2</sub> x2pcs
--	----------------------

# Schritt 3 Step 3

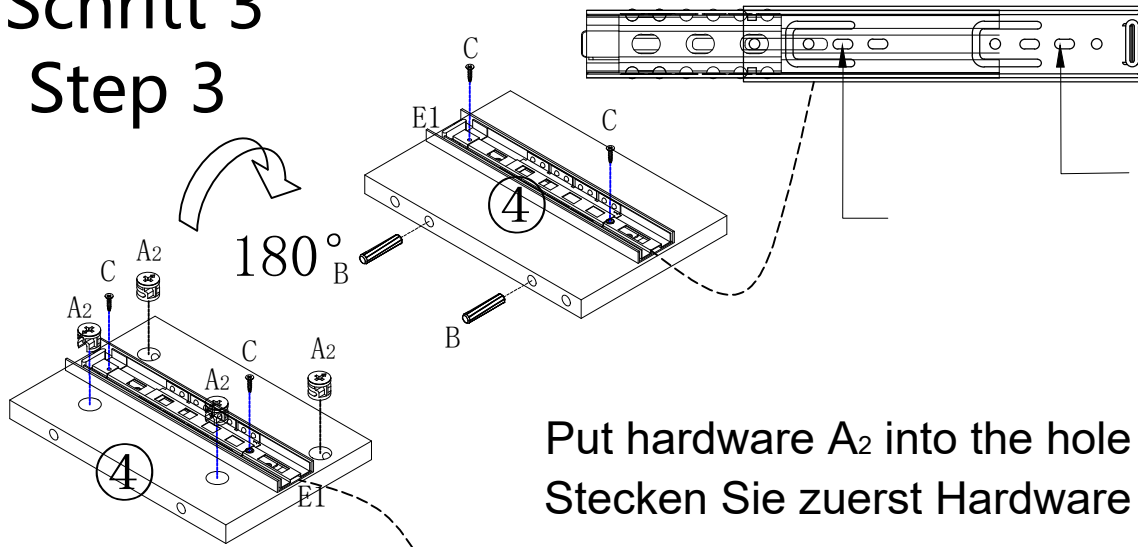

	A <sub>2</sub> x4pcs
	Bx2pcs
	C X 4PCS
	E1 X 2PCS

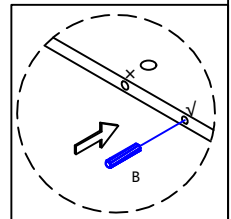
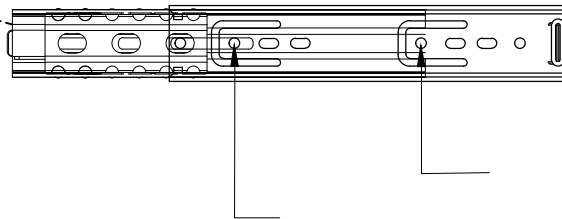

# Schritt4 Step 4

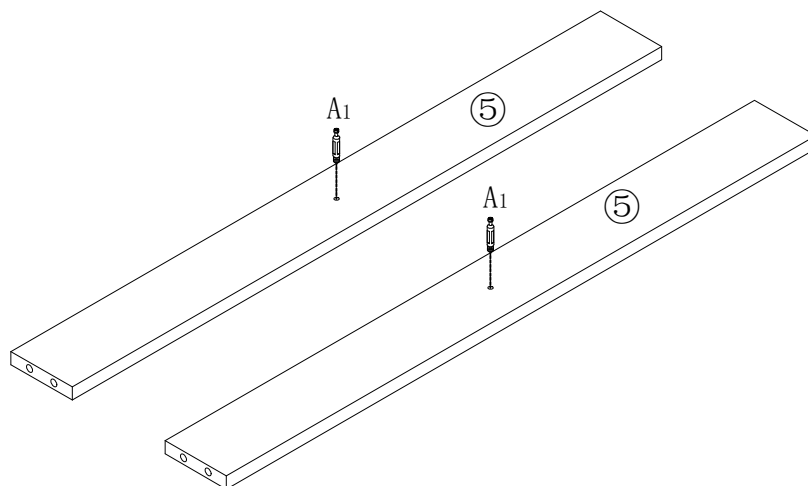

	A <sub>1</sub> x2pcs
--	----------------------

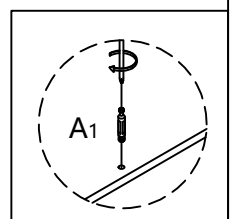

# Schritt 5

## Step 5

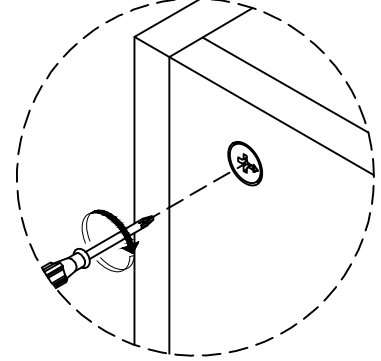
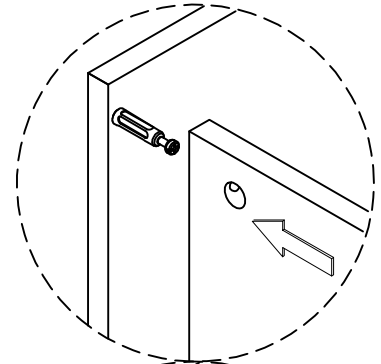
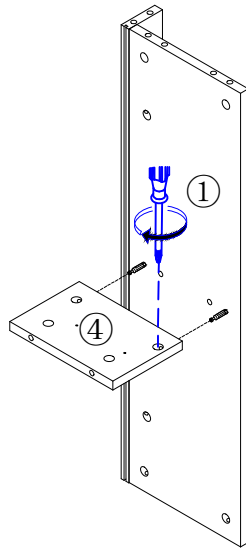

# Schritt 6



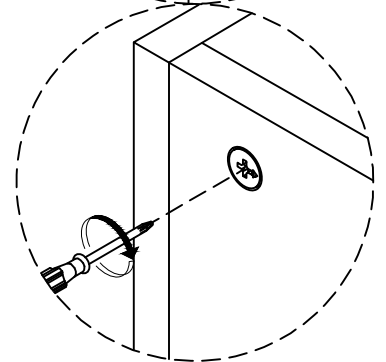
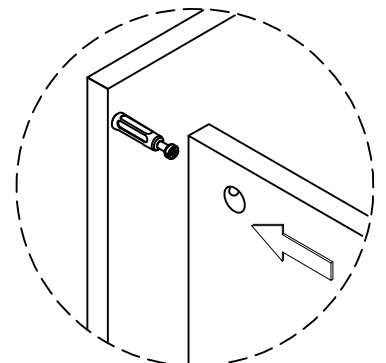
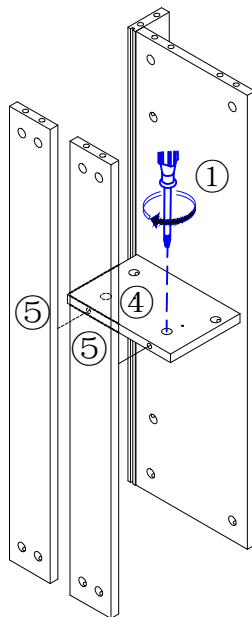

## Step 6

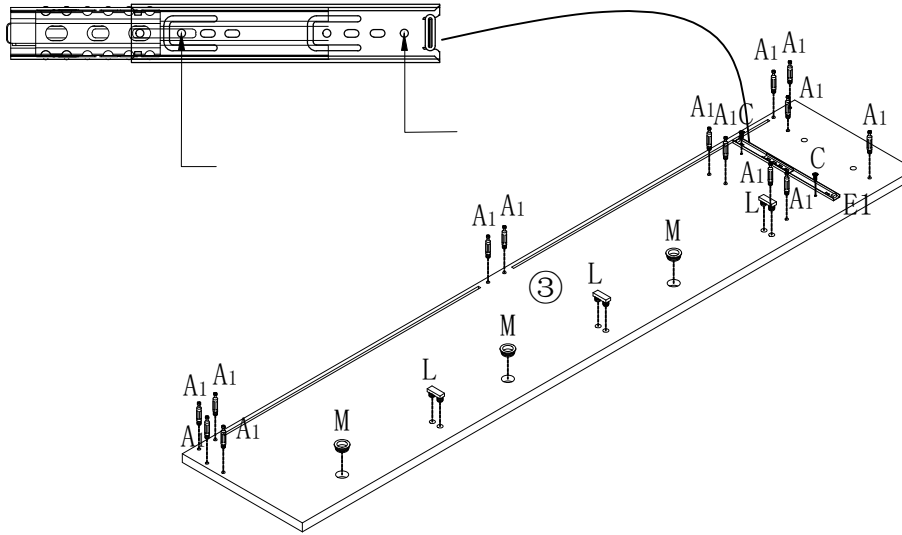

# Schritt 7

## Step 7



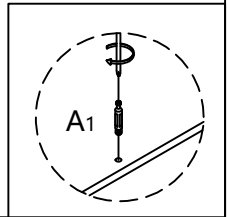

	A <sub>1</sub> x14pcs		Lx3pcs
	Cx2pcs		Mx3pcs
	E <sub>1</sub> x1pcs		

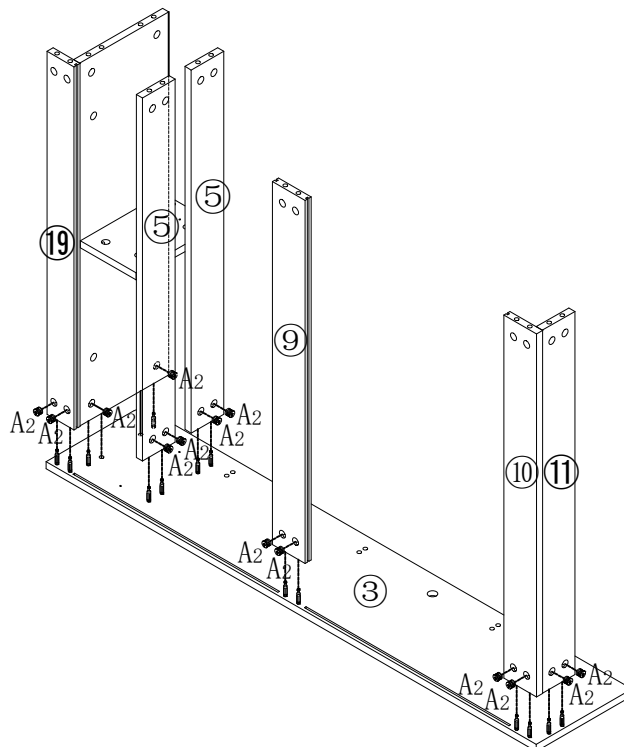

# Schritt 8

## Step 8



	A <sub>2</sub> x14pcs
--	-----------------------

# Schritt 9

## Step 9

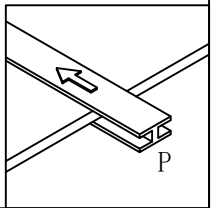
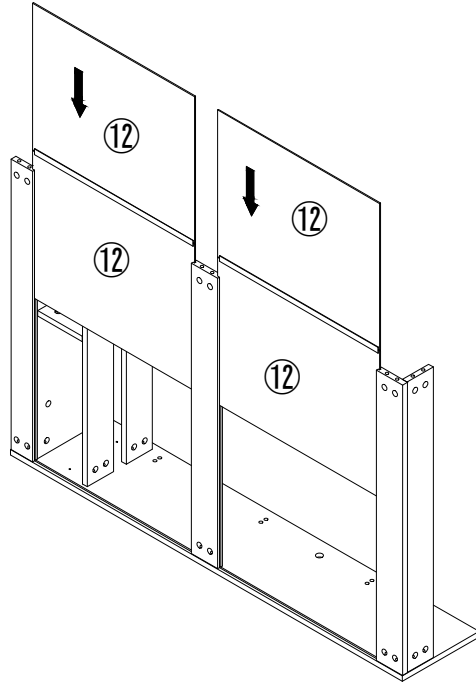

Px2pcs

# Schritt 10

## Step 10

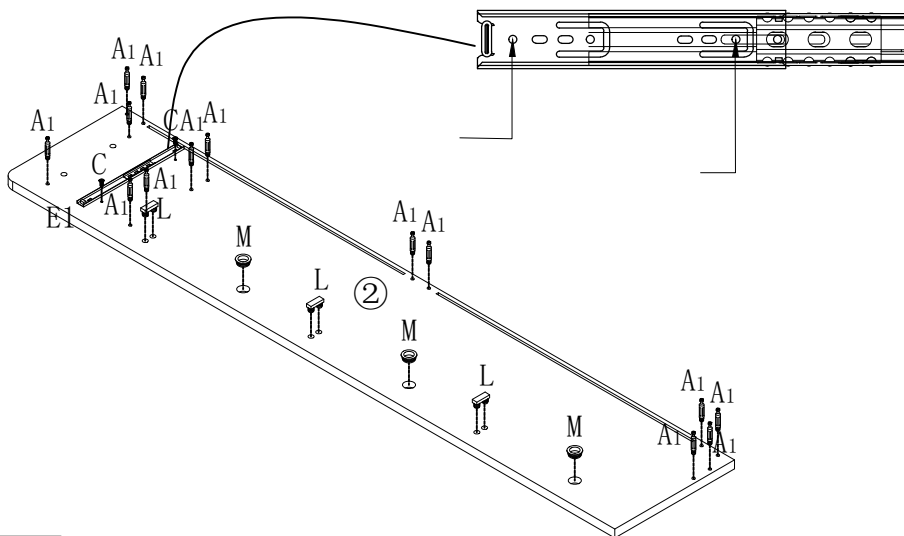

A<sub>1</sub>x14pcs



Cx2pcs



Lx3pcs



E<sub>1</sub>x1pcs



Mx3pcs

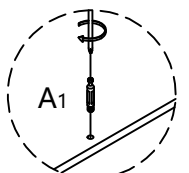

# Schritt 11

## Step 11

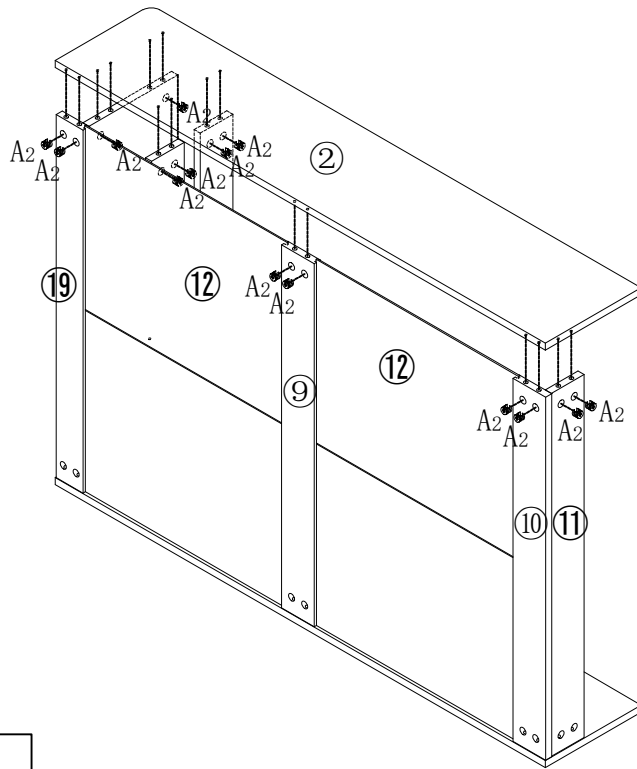

A2x14pcs

# Schritt 12

## Step 12

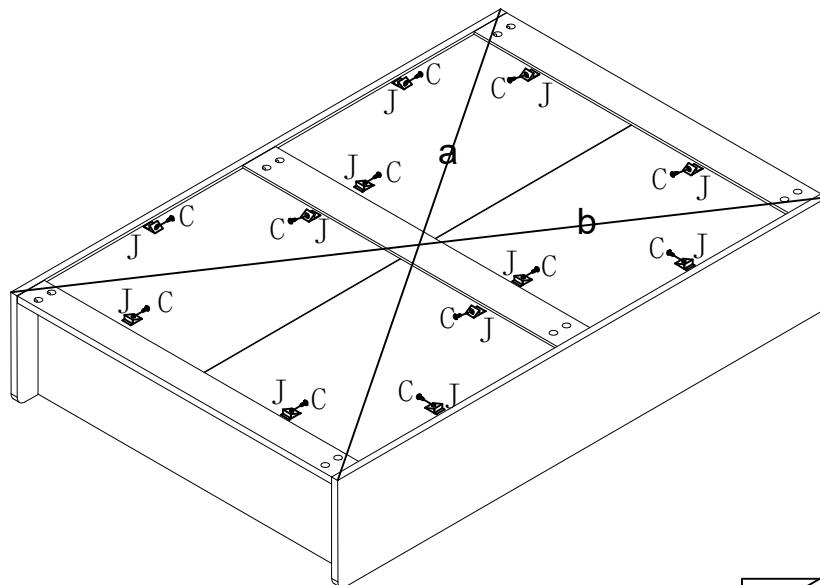

$a=b \sqrt{}$



Cx12pcs



Jx12pcs

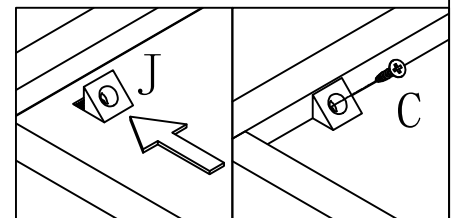



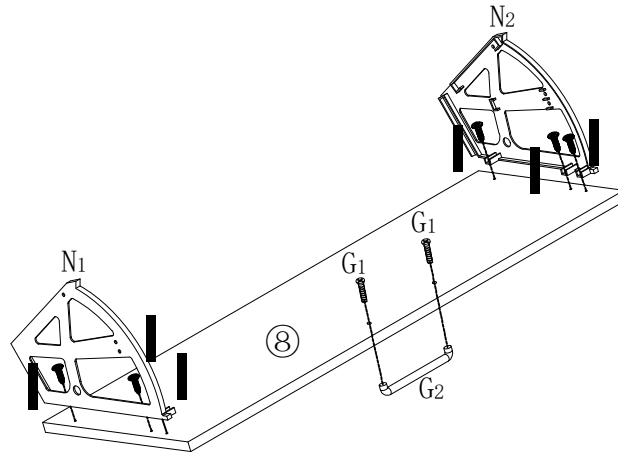

# Schritt 13

## Step 13



**X3**

	Ix18PCS
	N1x3PCS
	N2x3PCS
	G1x6PCS
	G2x3PCS

# Schritt 14

## Step 14

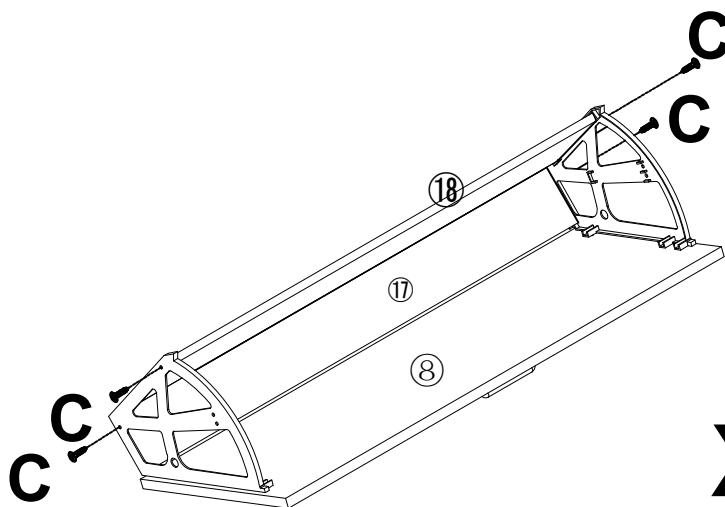

**X3**

	Cx12pcs
--	---------



# Schritt 15

## Step 15

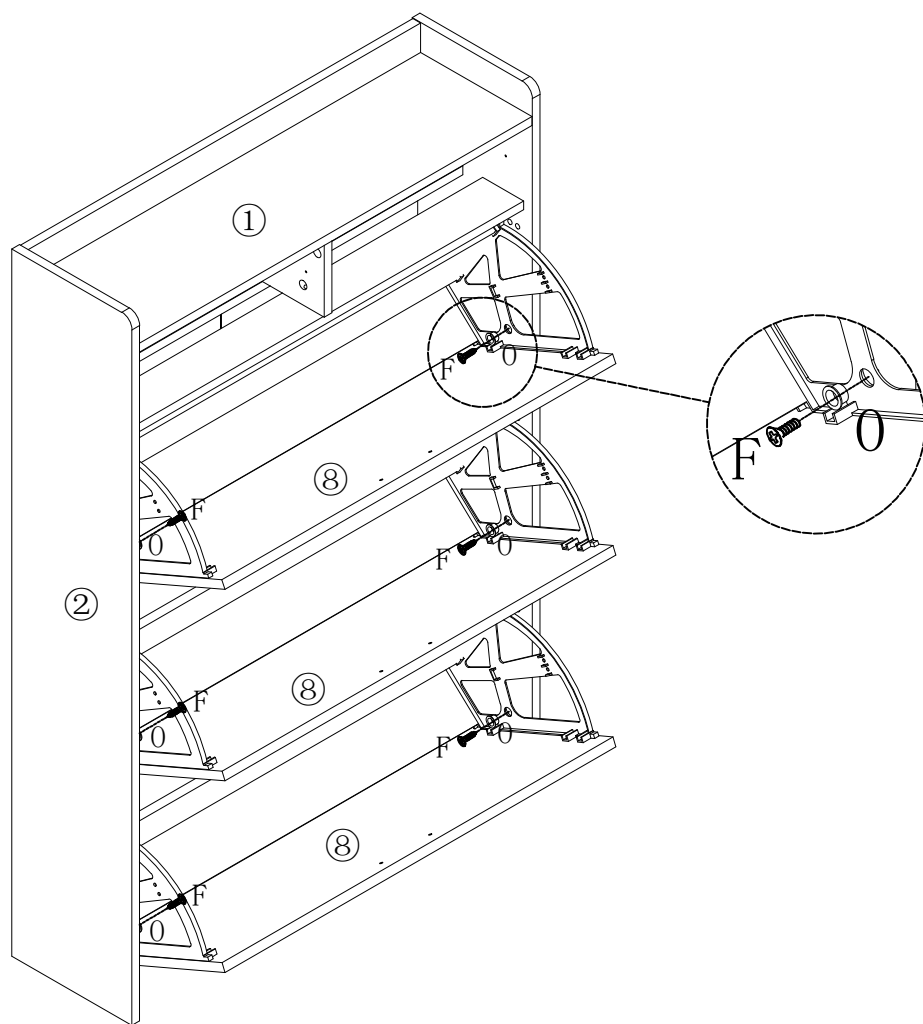

Ox6PCS



Fx6PCS

# Schritt 16

## Step 16

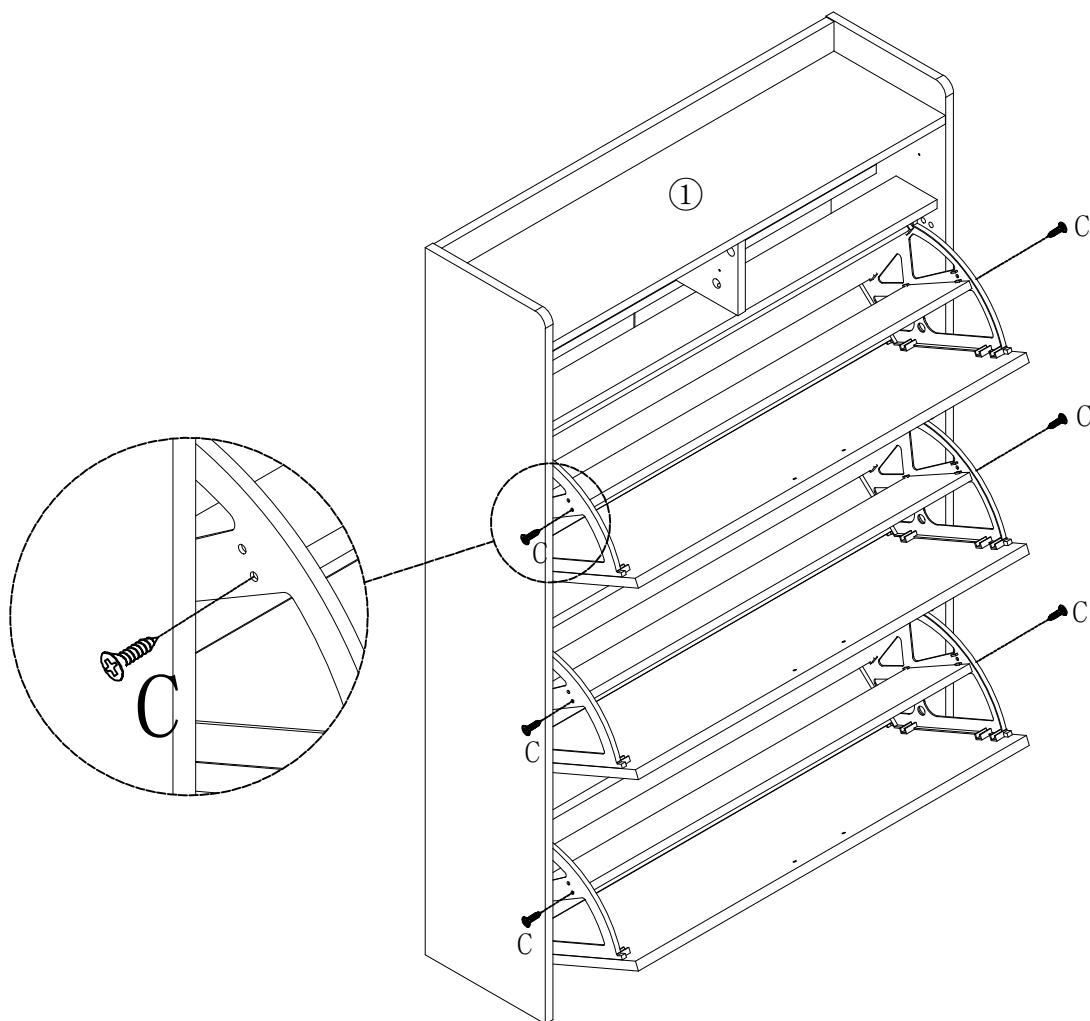

Cx6pcs

# Schritt 17

## Step 17

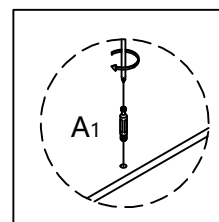
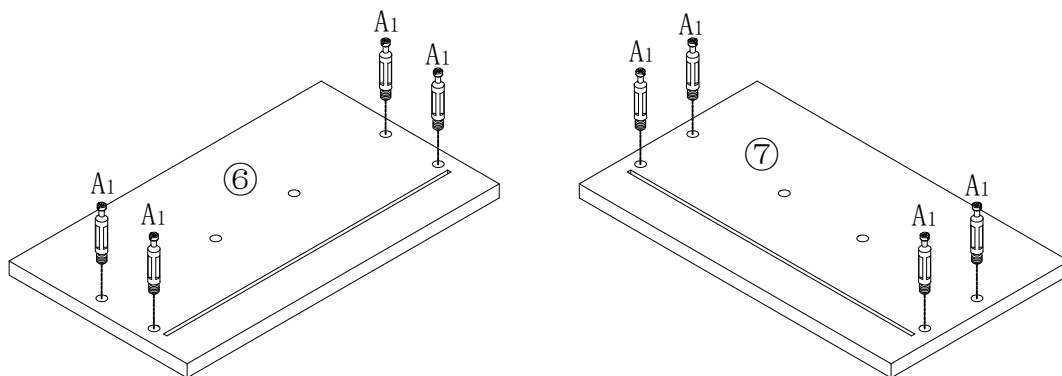

A<sub>1</sub>x8pcs

# Schritt 18

## Step 18

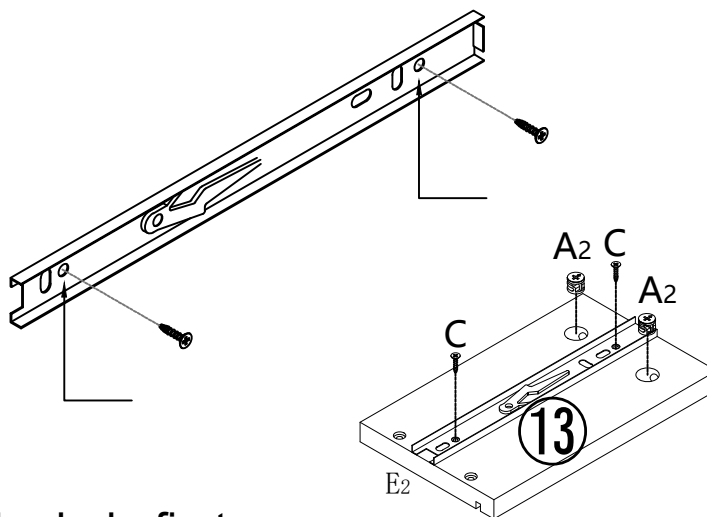

**X2**

Put hardware A<sub>2</sub> into the hole first

Stecken Sie zuerst Hardware A<sub>2</sub> in das Loch

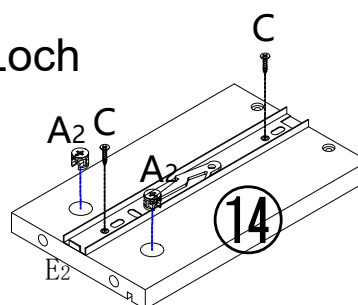

Cx8pcs

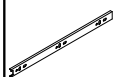

E<sub>2</sub>x4pcs



A<sub>2</sub>x8pcs

# Schritt 19

## Step 19

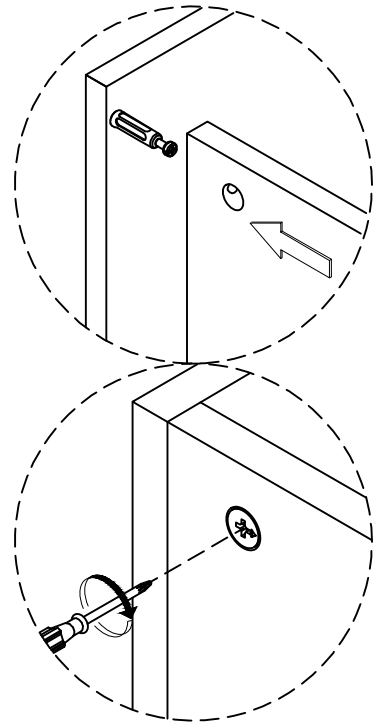
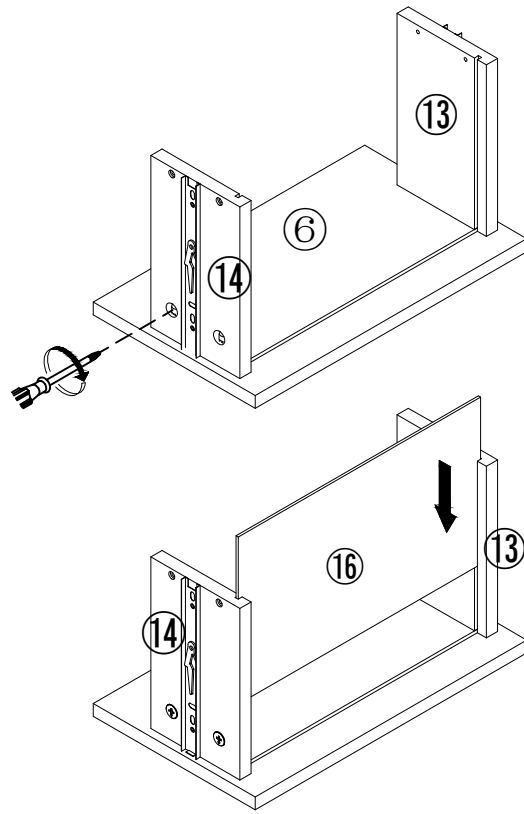

# Schritt 20

## Step 20

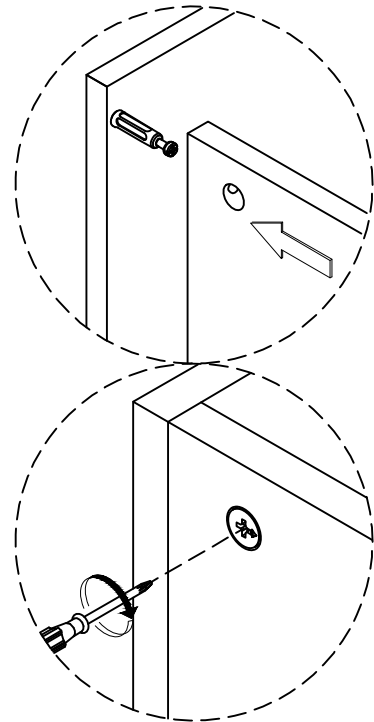
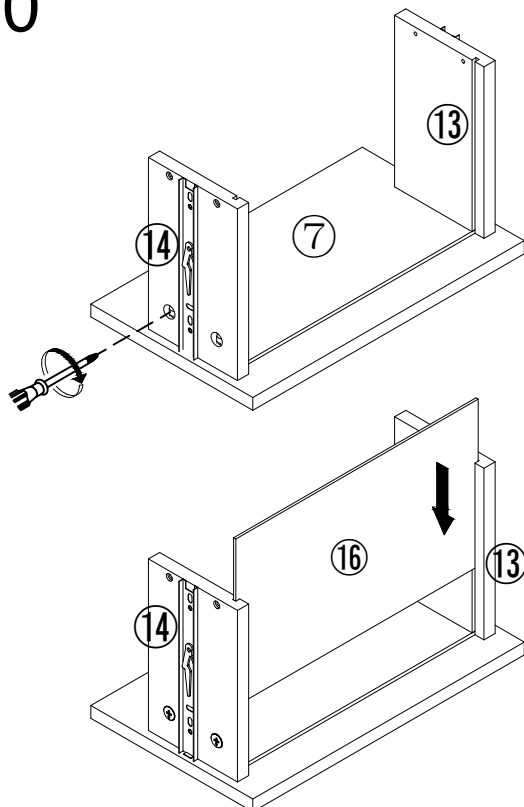

# Schritt 21

## Step 21

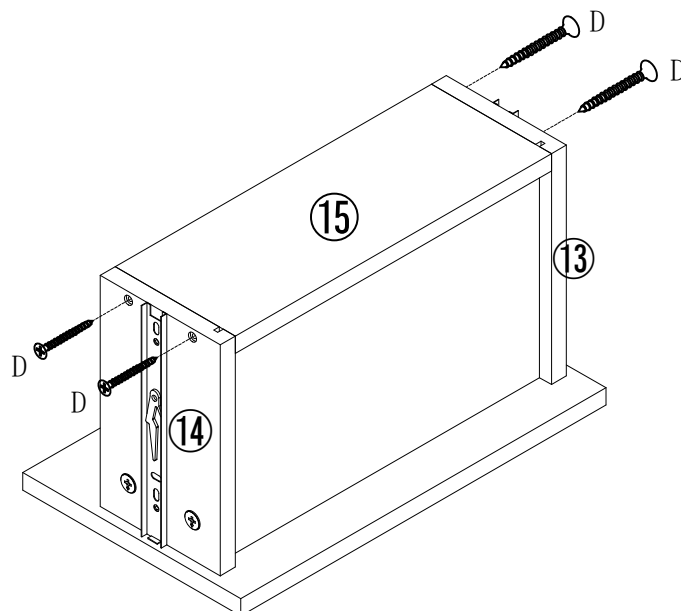

Dx4pcs

# Schritt 22

## Step 22

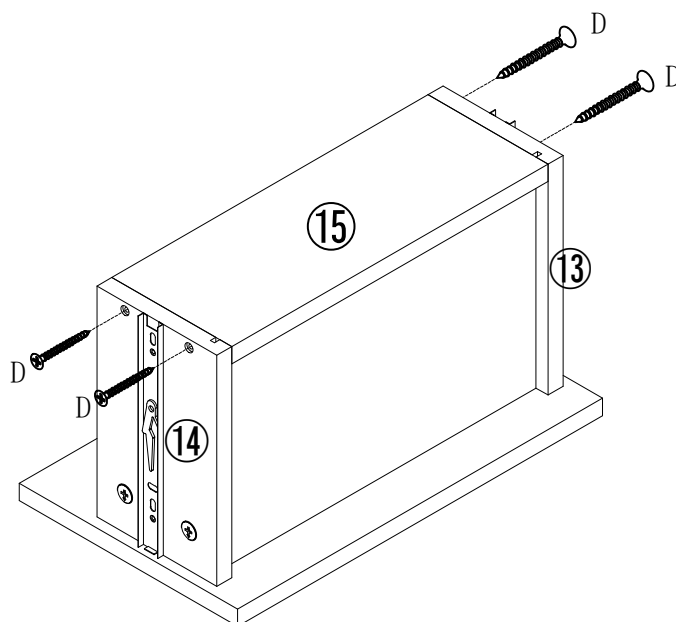

Dx4pcs

# Schritt 23

## Step 23

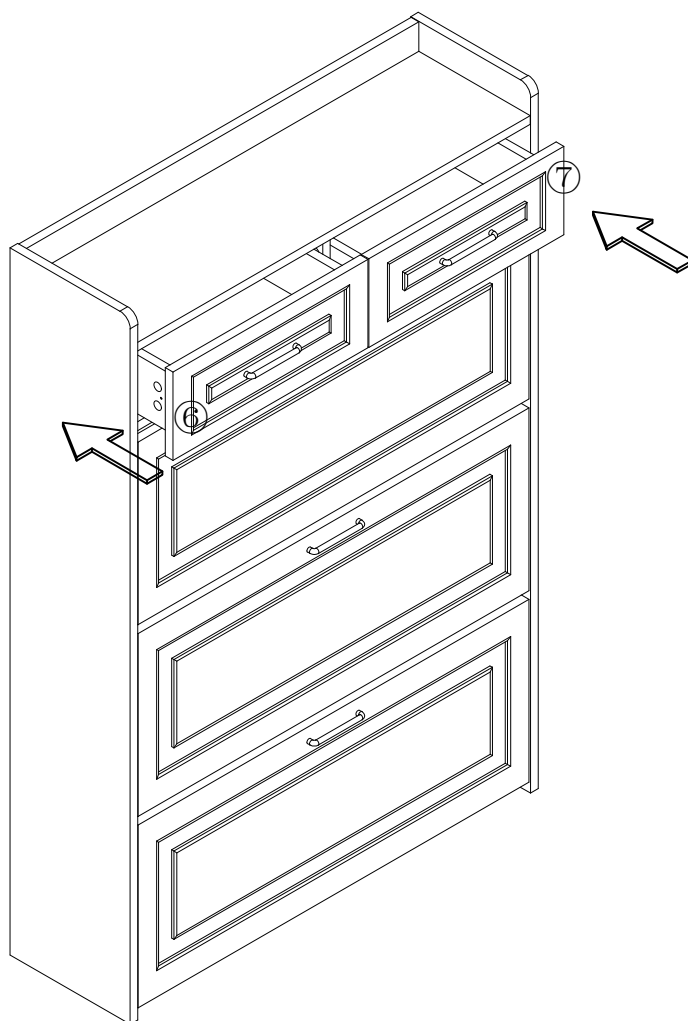
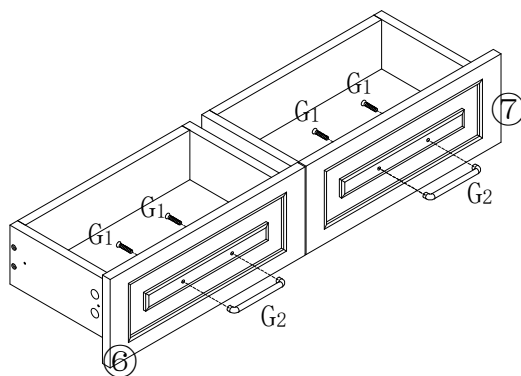

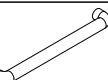

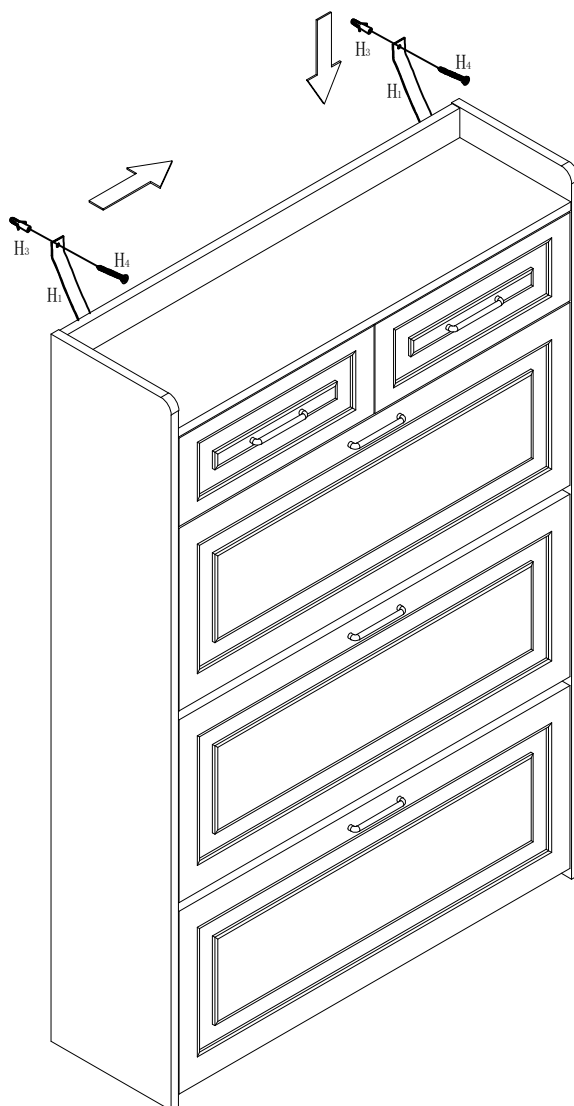

	<b>G1x4PCS</b>
	<b>G2x2PCS</b>

# Schritt 24

## Step 24



	H <sub>1</sub> x2pcs
	H <sub>2</sub> x2pcs
	H <sub>3</sub> x2pcs
	H <sub>4</sub> x2pcs

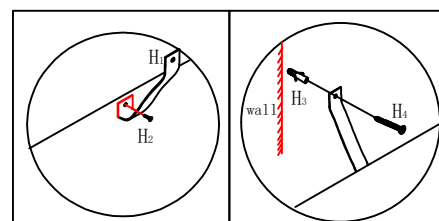

# Schritt 25

## Step 25

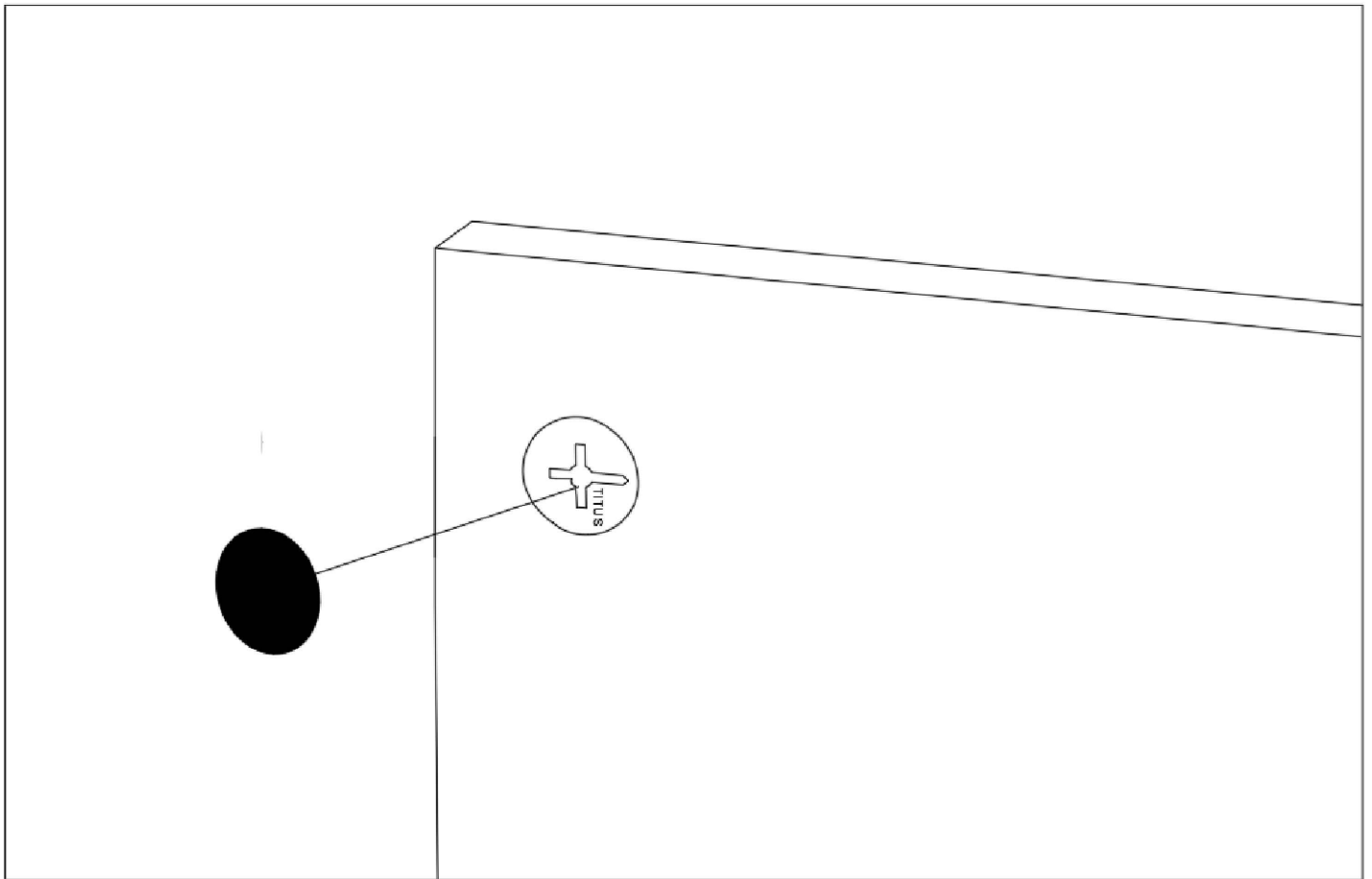

UK: After installing the product, stick the number S on the perforated position

FR: Une fois le produit installé, collez le numéro S à l'endroit où il y a des trous

DE: Nach der Installation des Produkts kleben Sie die Nummer S auf die perforierte Position



Sx42pcs