

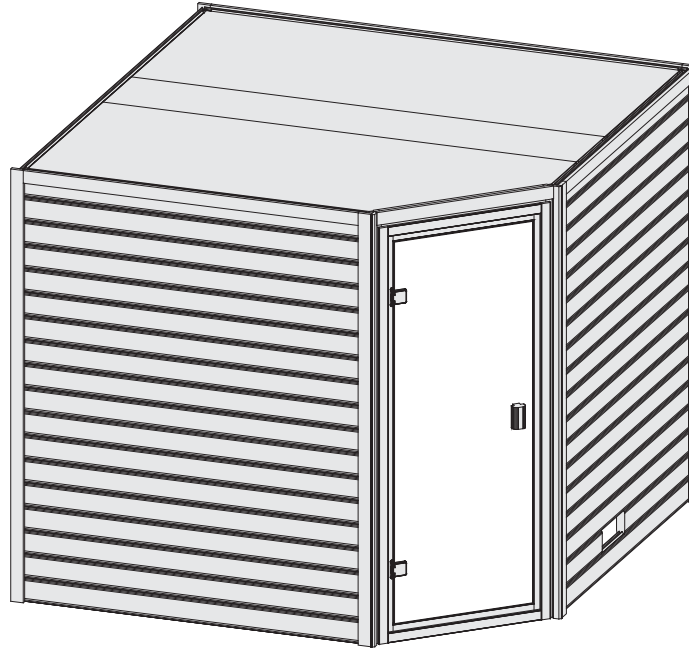

26655

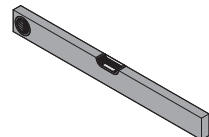

-  **Aufbauanleitung**
-  **Building Instructions**
-  **notice de montage**
-  **montagehandleiding**
-  **Montagevejledning**
-  **Instrucciones de construcción**
-  **Istruzioni per il montaggio**
-  **Montážní návod**

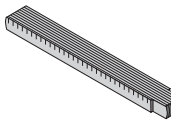
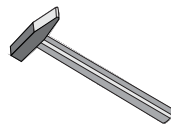
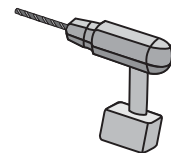
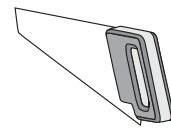





 Bitte bewahren Sie die Anleitung und den Garantieschein zur Seriennummer auf. Vernichten Sie diese erst nach Ablauf der Garantiezeit. Eventuelle Beanstandungen können mithilfe der Stückliste einfacher zugeordnet werden.





Beigelegte Dokumente:

- Informationsheft
- Garantieschein zur Seriennummer
- Typenschild inkl. Warnhinweise (Sauna)
- ggf. Zubehör-Anleitungen in externen Paketen

- \*  Nicht im Lieferumfang enthalten  
 Not included  
 Non comprises dans la livraison  
 Niet bijgeleverd



-  No forman parte del suministro  
 Non incluso  
 V ceně není zahrnuto  
 Ikke inkluderet

- 1  Länge muss ermittelt und zugesägt werden  
 Length must be determined and sawn  
 La longueur doit être déterminée et sciée  
 De lengte moet worden bepaald en worden gezaagd

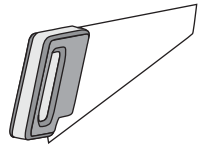
-  La longitud debe ser determinada y aserrada  
 La lunghezza deve essere determinata e segata  
 Délka musí být určena a rozřezána  
 Længden skal bestemmes og saves



- 2  Nicht gebraucht  
 Not needed  
 Pas nécessaire  
 Niet nodig





-  No es necesario  
 Non necessario  
 Není nutná

- 3  mit Zubehör!  
 met toebehoren!  
 with accessories!  
 avec accessoires!





-  con accesorios!  
 con accessori!  
 s příslušenstvím!  
 z dodatki!





- 4  Fixiert vorübergehend  
 tijdelijk vast  
 Fixed temporarily  
 temporairement fixe

-  temporalmente fijo  
 temporaneamente fisso  
 dočasně pevný  
 Zčasno pritrjeno

- 5  Bestand vom Haus  
 Inventaris van het huis  
 Inventory of the house  
 Inventaire de la maison

-  Inventario de la casa  
 Inventario della casa  
 Inventář domu  
 Inventar hiše

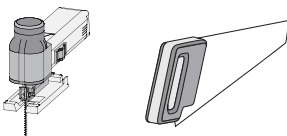
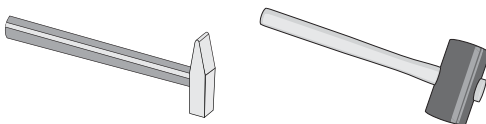
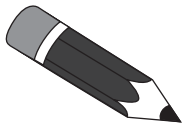
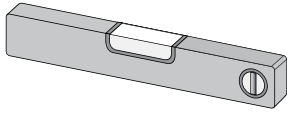
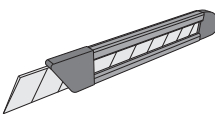
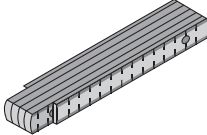
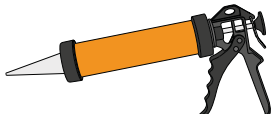
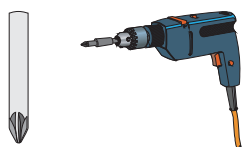
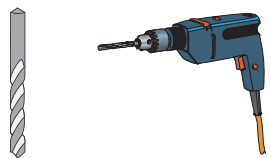
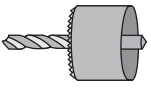
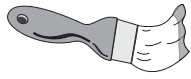
Werkzeuge / Tools\*

X	
X	
X	
X	
X	
X	
	
X	
X	
	
	
X	

Technische Daten

In der Auftragsbestätigung bzw. Lieferschein ist der gekaufte Ofentyp bzw. das erworbene Steuergerät zu finden. Bitte entnehmen Sie die technischen Daten Ihrer Geräte der folgenden Auflistung

Gerät	Netzspannung	Wattage
<b>Öfen</b>		
9kW Ofen Bio	400V ~ 3N	9kW
9kW Ofen (Finnisch)	400V ~ 3N	9kW
9kW Ofen integr. Steuerung	400V ~ 3N	9kW
4,5kW Ofen Bio	400V ~ 3N	4,5kW
4,5kW Ofen (Finnisch)	400V ~ 3N	4,5kW
4,5kW Ofen integr. Steuerung	400V ~ 3N	4,5kW
3,6kW Ofen Bio	230V ~ 1N	3,6kW
3,6kW Ofen (Finnisch)	230V ~ 1N	3,6kW
3,6kW Ofen integr. Steuerung	230V ~ 1N	3,6kW
<b>Steuergeräte</b>		
externe Steuerung Easy Bio	400V ~ 3N	max. 10,8kW
externe Steuerung Plug&Play Bio	240V ~ 3N	max. 10,8kW
externe Steuerung (Finnisch)	400V ~ 3N	max. 10,8kW
externe Steuerung Plug&Play (Finnisch)	240V ~ 3N	max. 10,8kW
Multisteuergerät	400V ~ 3N	max. 10,5kW
externe Steuerung Classic Bio	400V ~ 3N	max. 9kW
externe Steuerung Classic (Finnisch)	400V ~ 3N	max. 9kW
externe Steuerung Premium Bio	400V ~ 3N	max. 12kW
externe Steuerung Premium (Finnisch)	400V ~ 3N	max. 9kW



Vergleichen Sie zuerst die Materialliste mit Ihrem Paketinhalt! Bitte haben Sie Verständnis, dass Beanstandungen nur im nicht aufgebauten Zustand bearbeitet werden können!



En primer lugar, compare la lista de material con el contenido del paquete. Rogamos entienda que las reclamaciones sólo pueden ser tramitadas antes de montar el objeto!



Nejprve přezkontrolujte obsah balení podle materiálového listu! Mějte pochopení pro to, že případnou reklamaci se můžeme zabývat pouze tehdy, když díly nebudou smontované! Za pomoci tohoto seznamu můžete jednotlivé díly přiřadit k montážnímu návodu.



Vergelijk eerst de lijst van materialen met de inhoud van uw pakket! Reclamaties kunnen alleen in behandeling worden genomen zolang de onderdelen nog niet zijn gemonteerd!



First compare the list of materials with your package contents! Please understand that complaints can be processed in the non-built status only!



Commencez par comparer la liste du matériel avec le contenu de votre paquet! Sachez que nous traitons uniquement les réclamations concernant le matériel à l'état non monté!



Confrontate questa distinta materiali prima con il contenuto del pacchetto! Vi preghiamo di comprendere che eventuali reclami possono essere accolti solo prima del montaggio!

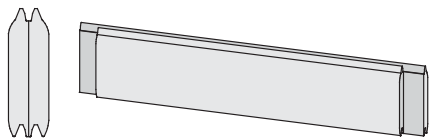
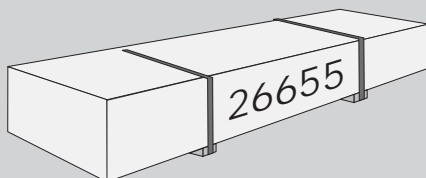

35 x A1	1628 x 121 x 38mm	ID 26150
35 x A2	2231 x 121 x 38mm	ID 21463

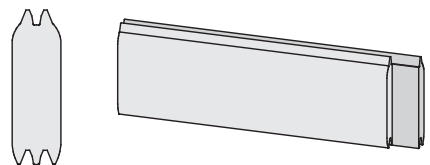

1 x A3	545 x 121 x 38mm	ID 21876
1 x A4	808 x 121 x 38mm	ID 80499

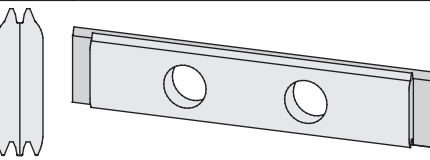

1 x A5	2231 x 121 x 38mm	ID 21866
--------	-------------------	----------

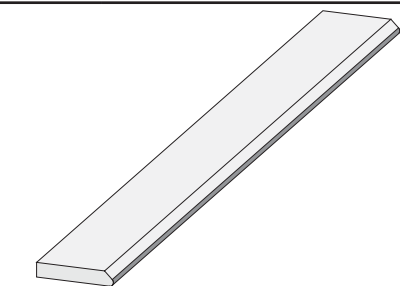

2 x F1	2000 x 58 x 17mm	ID 48545
--------	------------------	----------

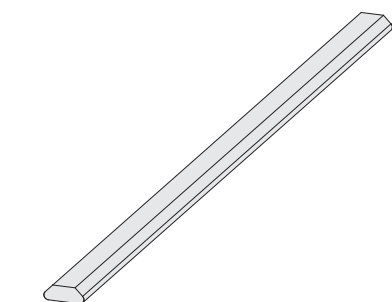

2 x F2	2100 x 40 x 18mm	ID 80276
--------	------------------	----------

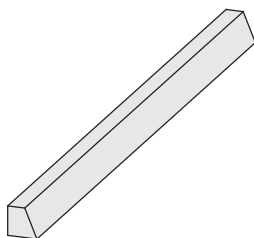

2 x C1	1916 x 36 x 36mm	ID 21814
2 x C2	1973 x 36 x 36mm	ID 21825

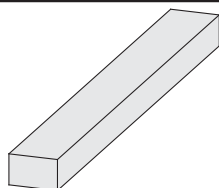

3 x B1	1920 x 20 x 3mm	ID 20799
1 x B2	1608 x 95 x 18mm	ID 71040
2 x B3	2156 x 95 x 18mm	ID 28687
1 x B4	850 x 58 x 17mm	ID 48544
8 x B5	2000 x 58 x 17mm	ID 48541
2 x B7	800 x 45 x 18mm	ID 24796
1 x B8	880 x 45 x 18mm	ID 21440
2 x B9	1556 x 45 x 18mm	ID 47603
2 x B10	2159 x 45 x 18mm	ID 21483
1 x B11	300 x 95 x 18mm	ID 19130
4 x B12	480 x 95 x 18mm	ID 20930
4 x B13	565 x 95 x 18mm	ID 15498
2 x B14	800 x 58 x 28mm	ID 15493
3 x B15	1916 x 36 x 36mm	ID 21431
1 x B16	781 x 78 x 38mm	ID 56718

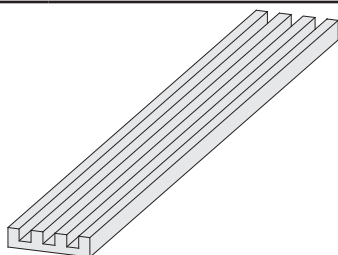

1 x E1	1850 x 110 x 26mm	ID 26480
--------	-------------------	----------

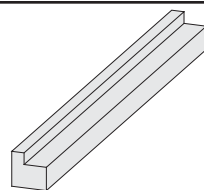

3 x E2	555 x 45 x 45mm	ID 40301
2 x E3	1100 x 45 x 45mm	ID 40302

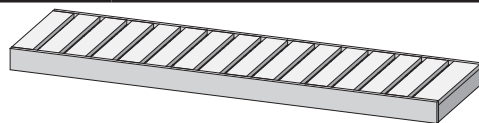

1 x L1	1610 x 500 x 90mm	ID 26791
2 x L2	2156 x 550 x 90mm	ID 55193

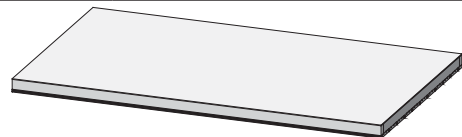

1 x M1	2189 x 350 x 57mm	ID 21482
1 x M2	2189 x 918 x 57mm	ID 21465

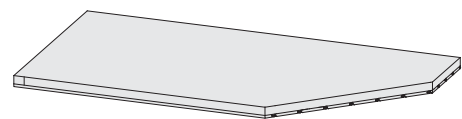

1 x M3	2189 x 918 x 57mm	ID 26152
--------	-------------------	----------



- Siehe Türpaket
- Opmerking Door Package
- Note Door Package
- Remarque Package porte
- Nota Paquete Puerta
- Nota Door Package
- Poznámka Door balíček

1 x D1		
--------	--	--

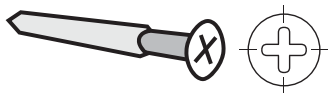

20 x	4 x 30mm	ID 3686
60 x	4 x 35mm	ID 3687
350 x	4 x 40mm	ID 21925
30 x	4 x 50mm	ID 3688
30 x	4 x 70mm	ID 3689
25 x	4,5 x 80mm	ID 9204
20 x	6 x 80mm	ID 47558
80 x	6 x 90mm	ID 26715



60 x S1	4 x 30mm	ID 26116
6 x S2	12 x 18mm	ID 46403

10m

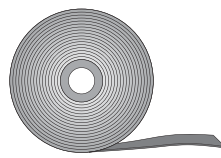

ID 14025



50 x	4,5 x 40mm	ID 26285
------	------------	----------

2 x

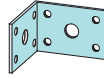

ID 20803

3 x S3



ID 14018

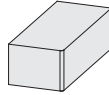

4 x K1	60 x 36 x 36mm	ID 5512
--------	----------------	---------

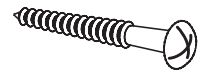

6 x	3 x 16mm	ID 46376
-----	----------	----------

1 x

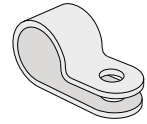

ID 50420



>10cm



>10cm



-  Draufsicht
-  Top view
-  vue de dessus
-  bovenaanzicht
-  vista desde arriba
-  vista desde arriba
-  vista dall'alto
-  pùdorys

01

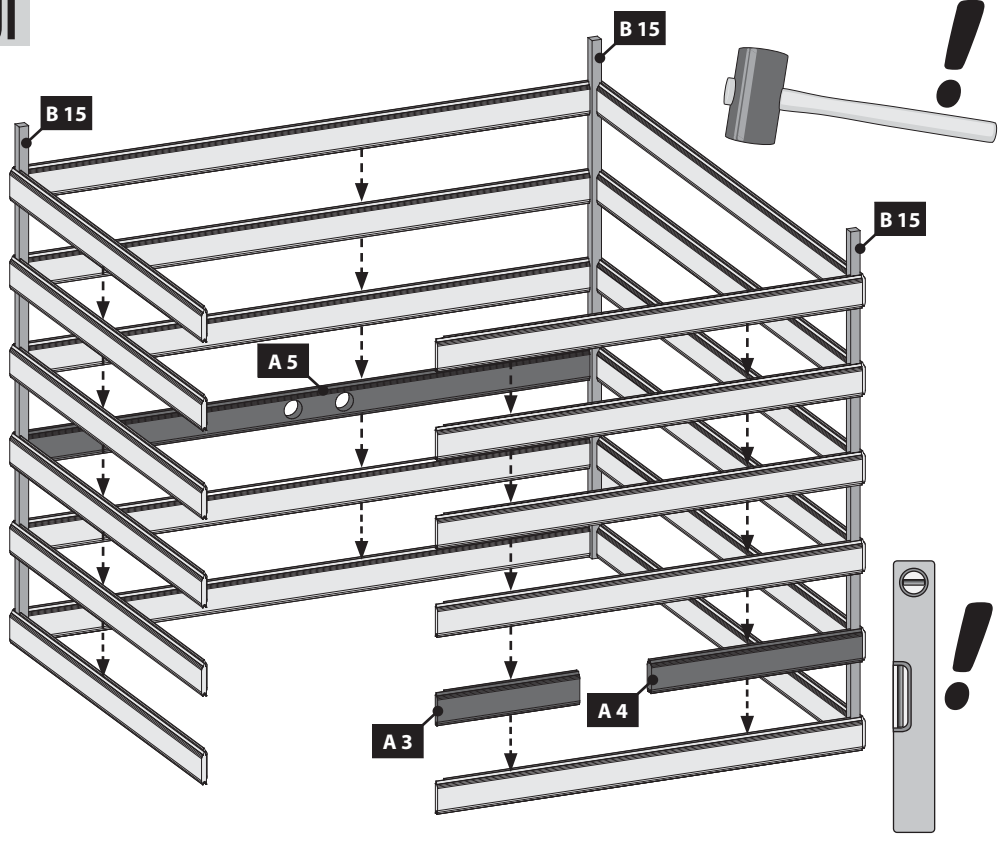

02.1

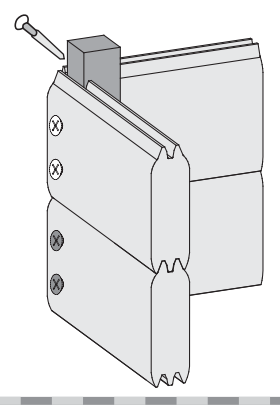



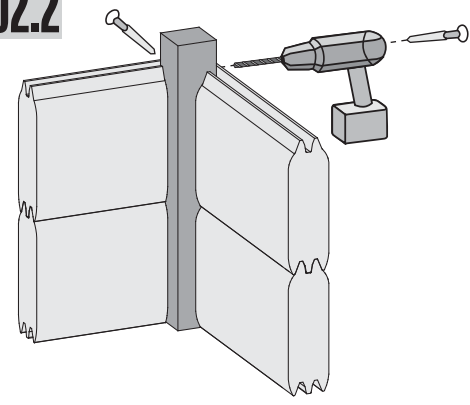

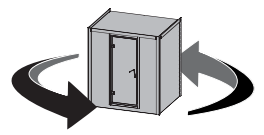

02.2



02.3



 Achten Sie auf die gleiche Höhe  
 Look for the same height  
 Faites attention à la même hauteur  
 Besteed aandacht aan de dezelfde hoogte

 Prestar atención a la misma altura  
 Prestare attenzione alla stessa altezza  
 Dávejte pozor na stejnou výšku

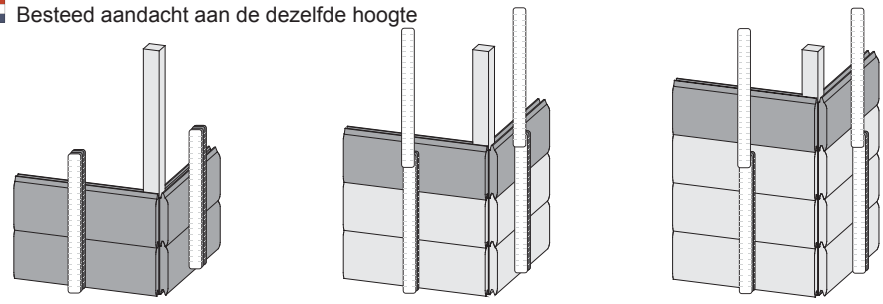

02

( 02.1 + 02.2 → 02.3 )

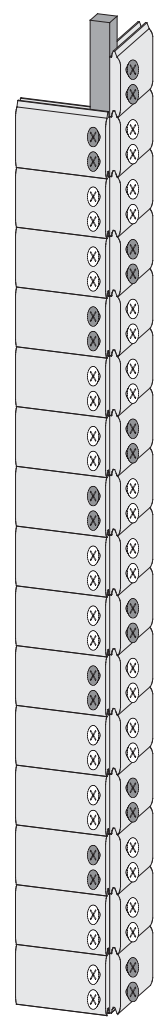
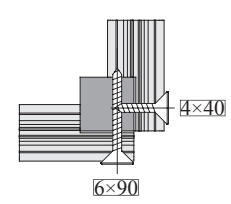
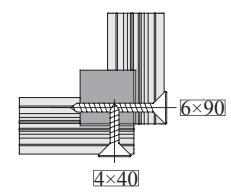
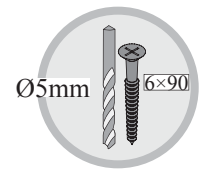
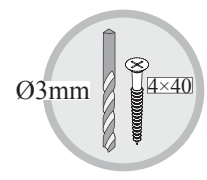
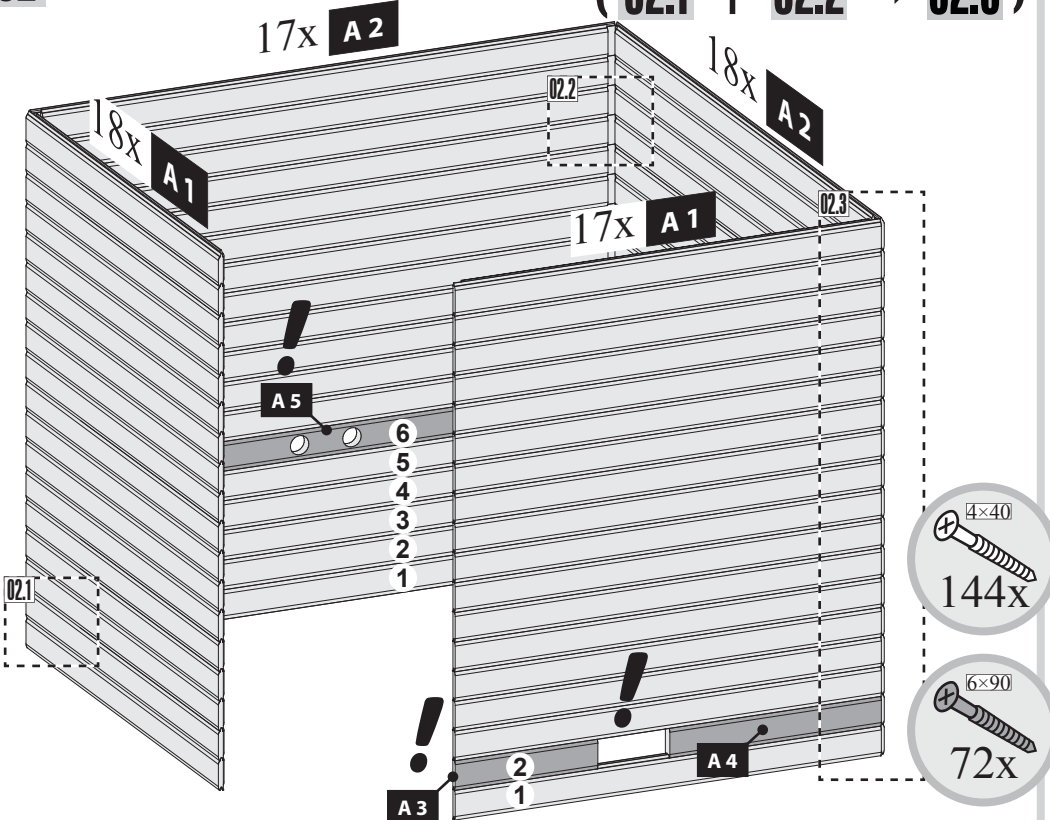

03

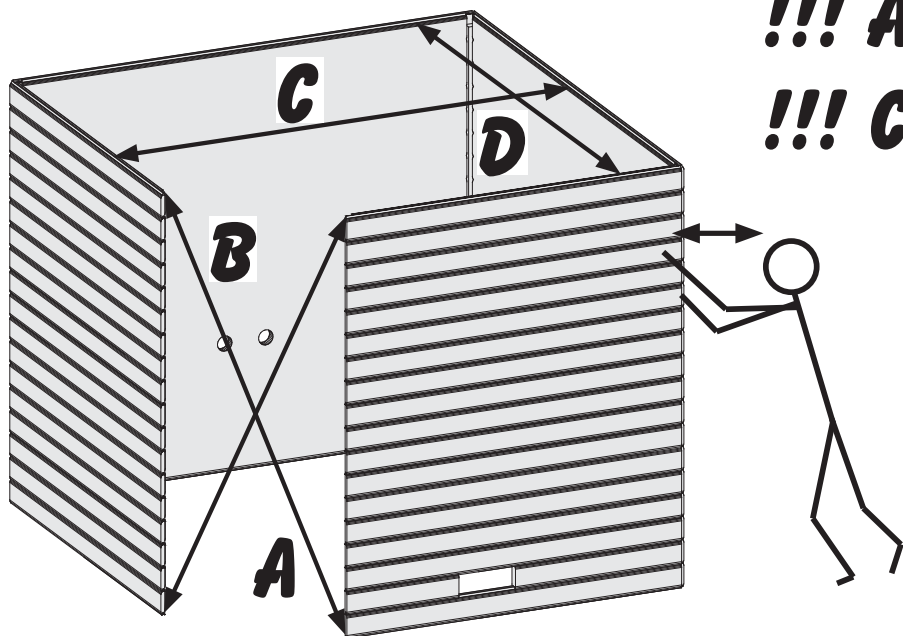

**!!! A=B !!!**

**!!! C=D !!!**

04.1

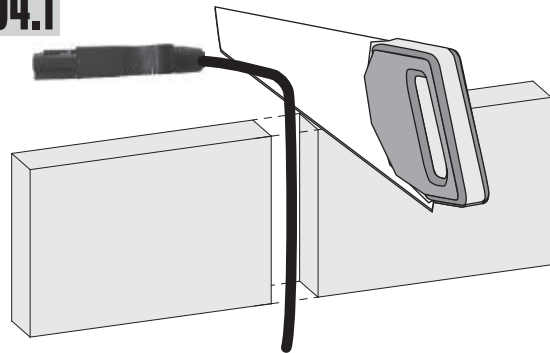

04

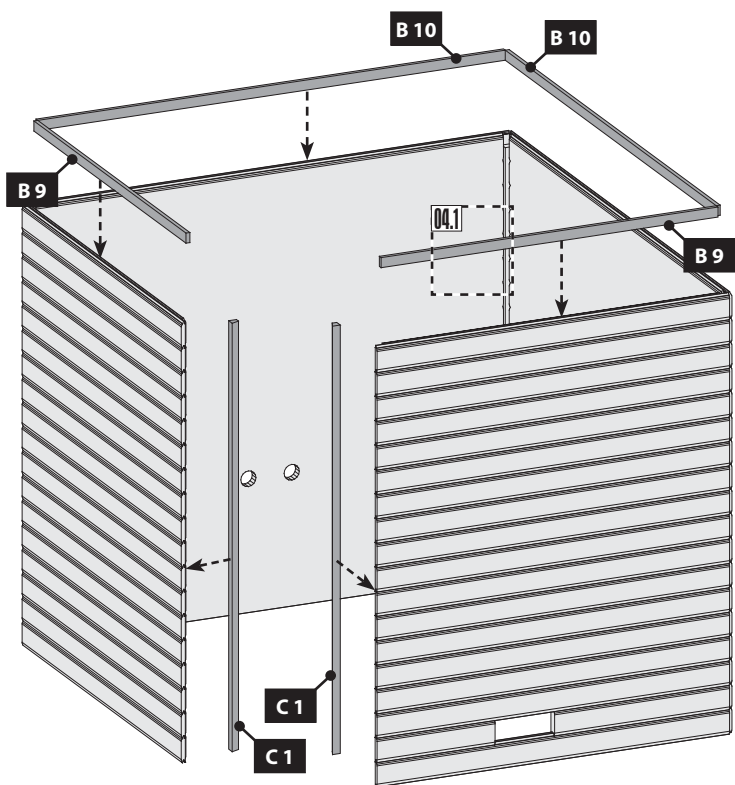

05

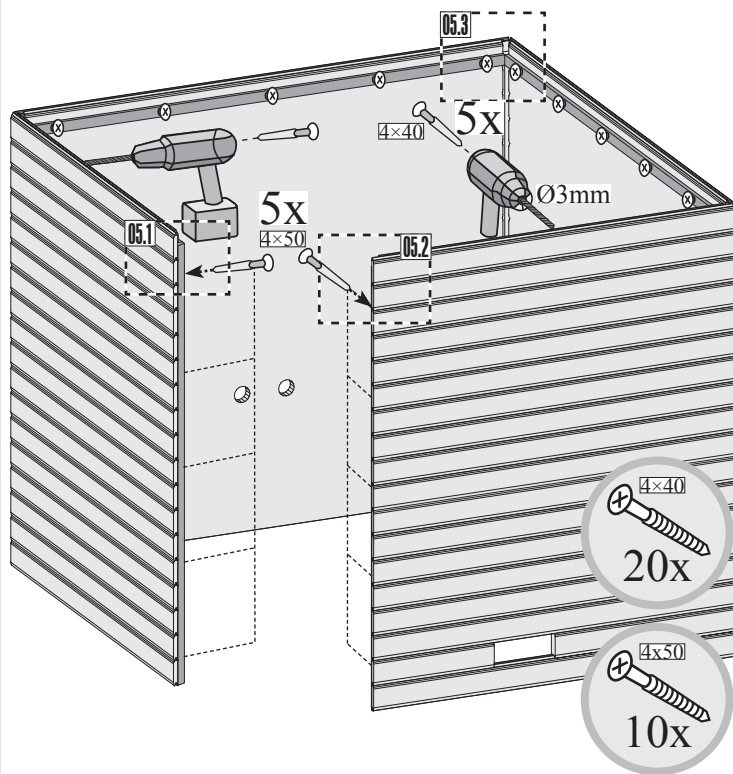
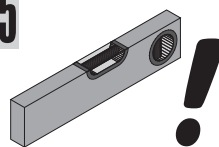

Bündig!  
Affleurement!  
Gelijk!  
Aras!  
Flush!  
Combacia!  
Stejný!

05.1

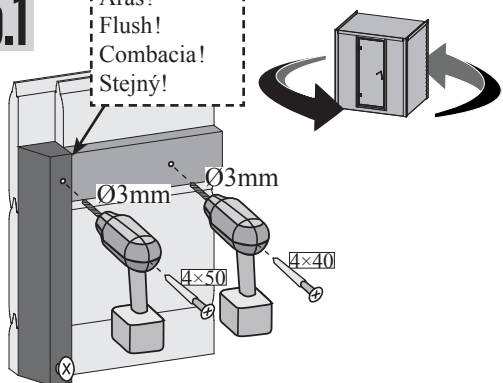

05.2

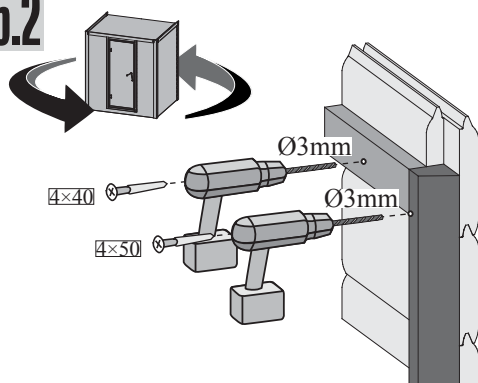

05.3

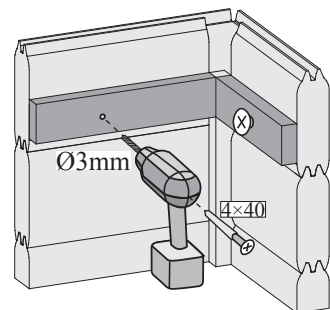

06

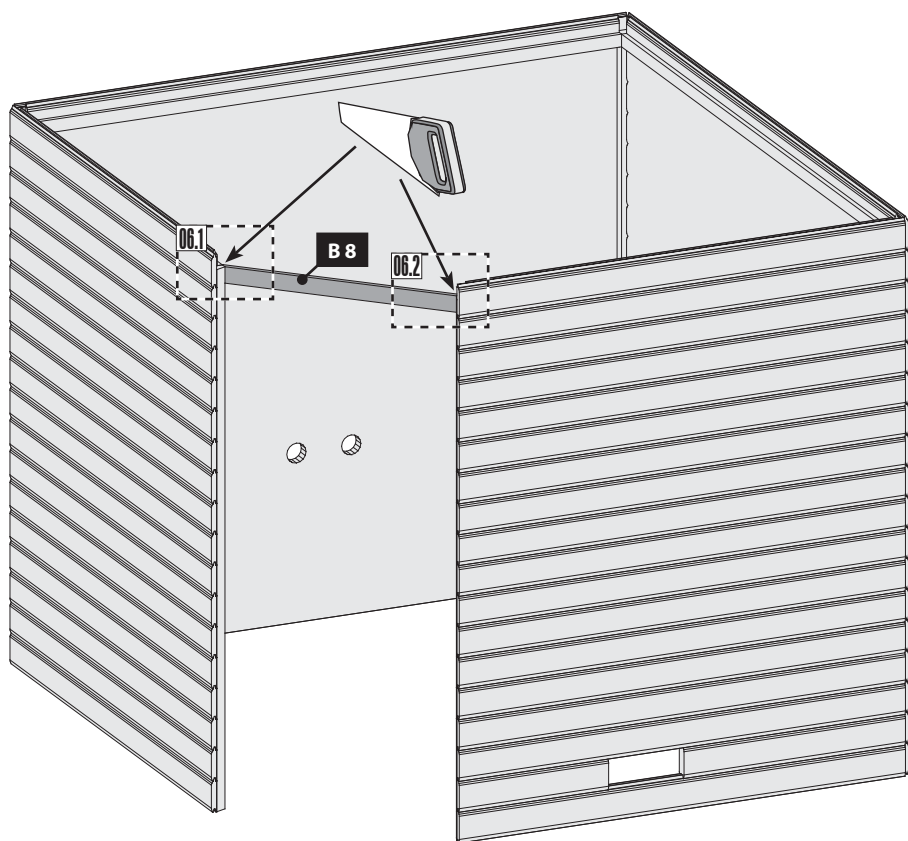

06.1

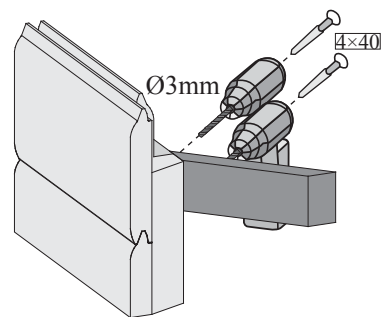

06.2

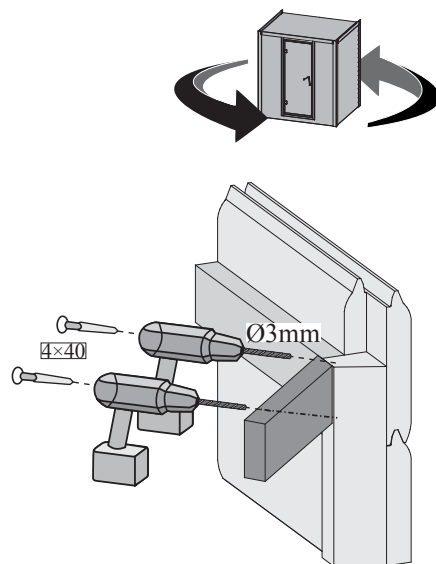

Bündig!  
Affleurement!  
Gelijk!  
Aras!  
Flush!  
Combacia!  
Stejný!

07

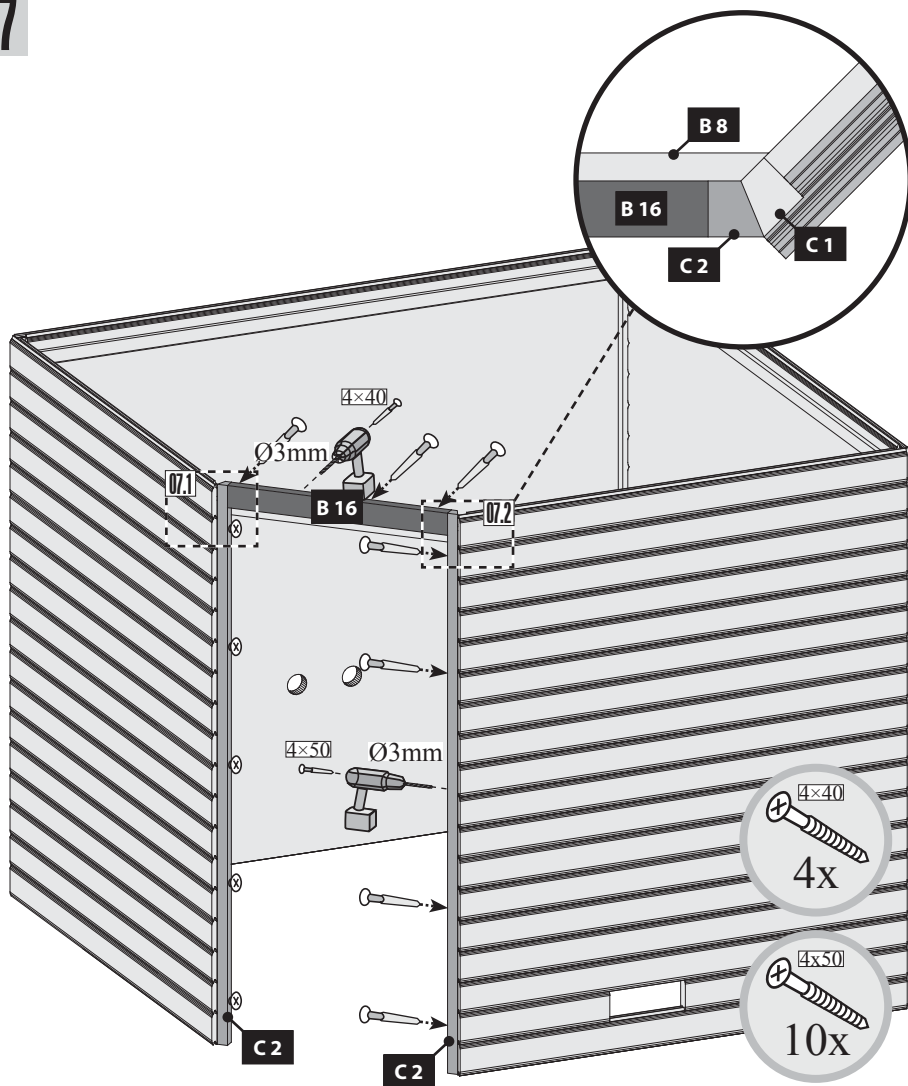

07.1

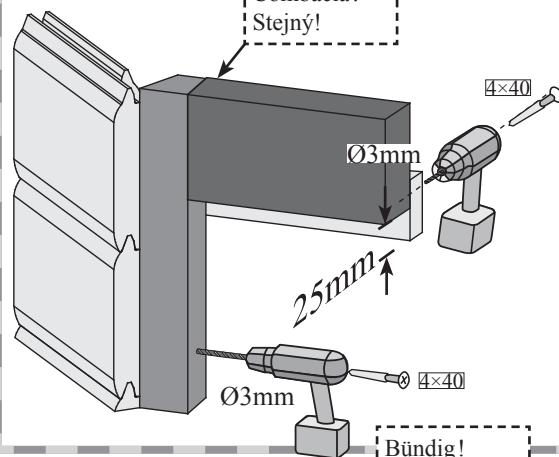

Bündig!  
Affleurement!  
Gelijk!  
Aras!  
Flush!  
Combacia!  
Stejný!

07.2

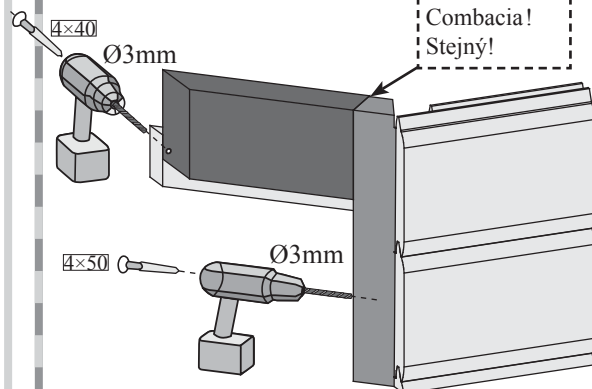





 Einbau Saunatür

 Sauna deur installatie

 Sauna Instalace dveře

 Installation de porte Sauna

 Instalación de la puerta Sauna

 Sauna door installation

 Installazione porta Sauna

**!!!** 01 → 03 **!!!**

08

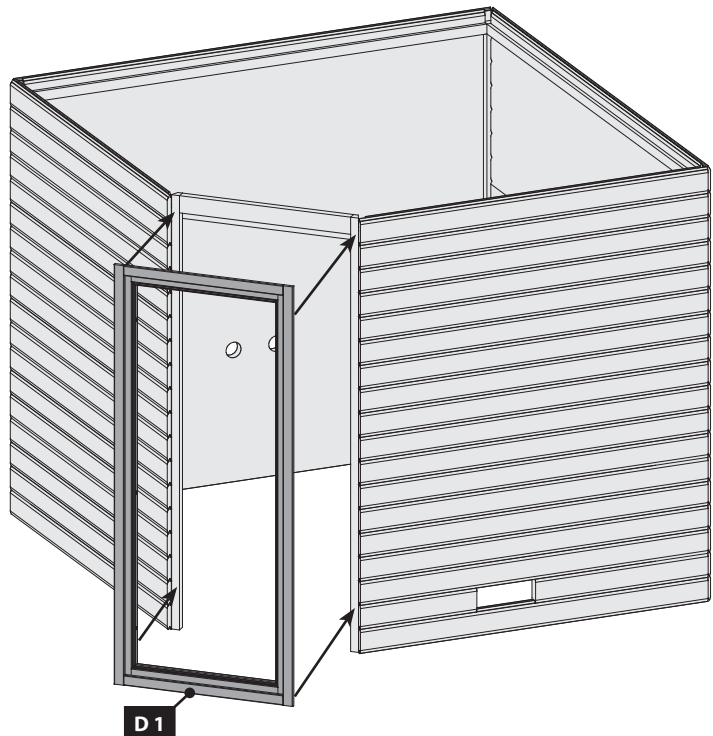

09

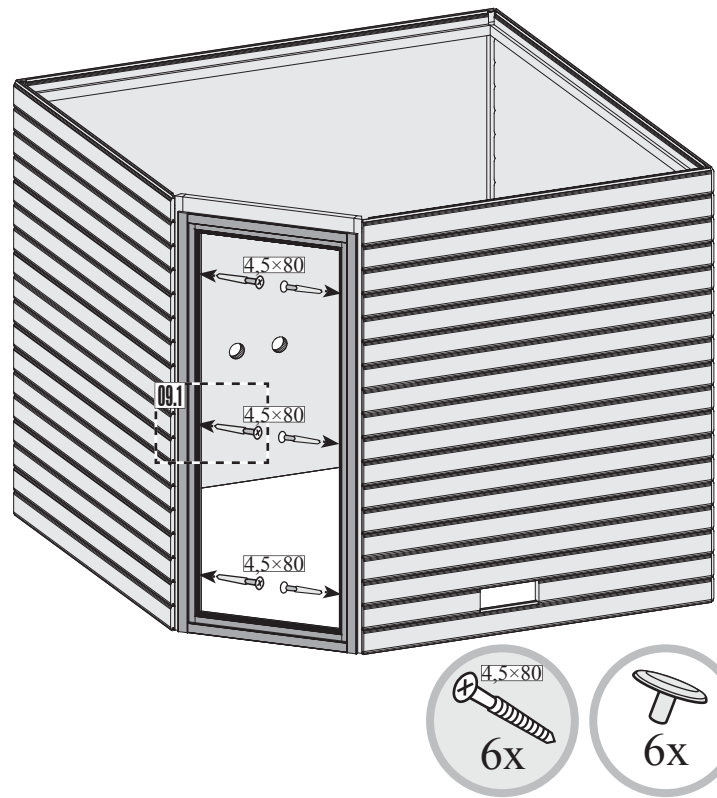

10

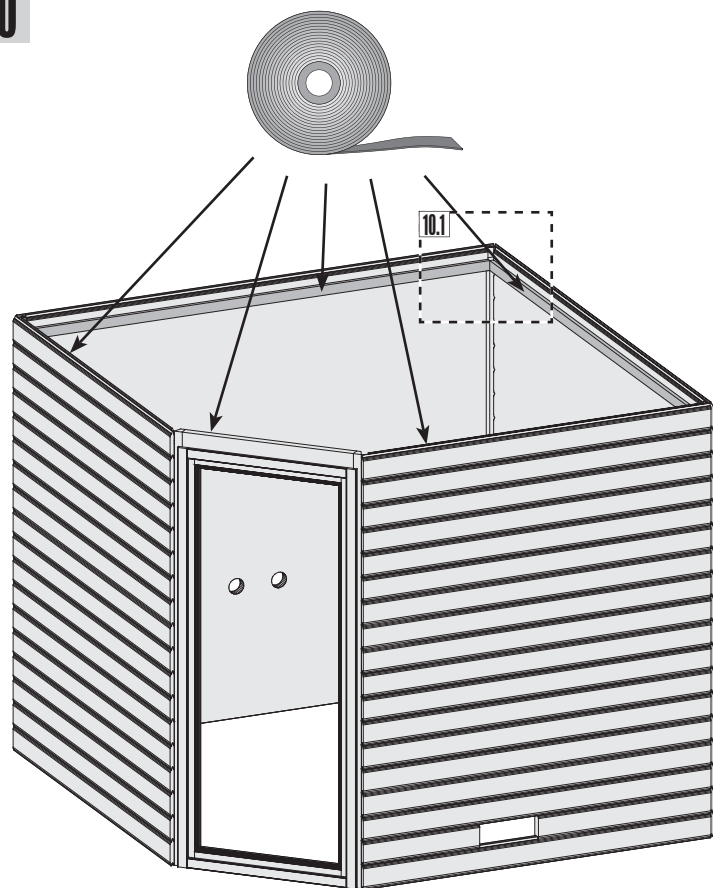

09.1-1

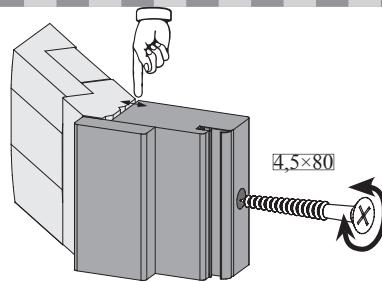

09.1-2

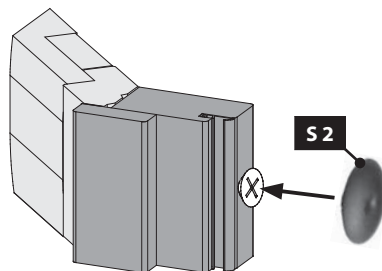

10.1

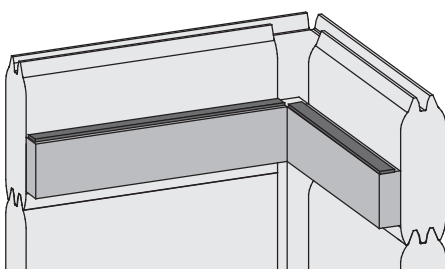

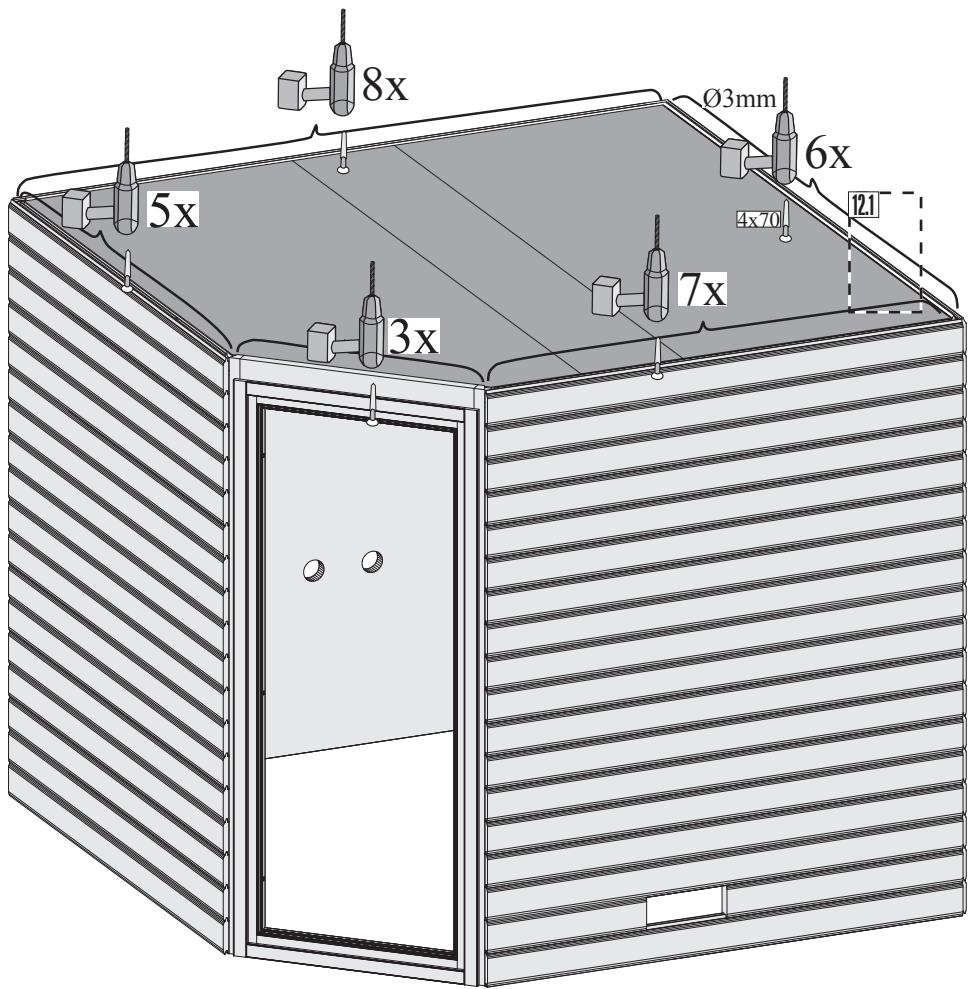
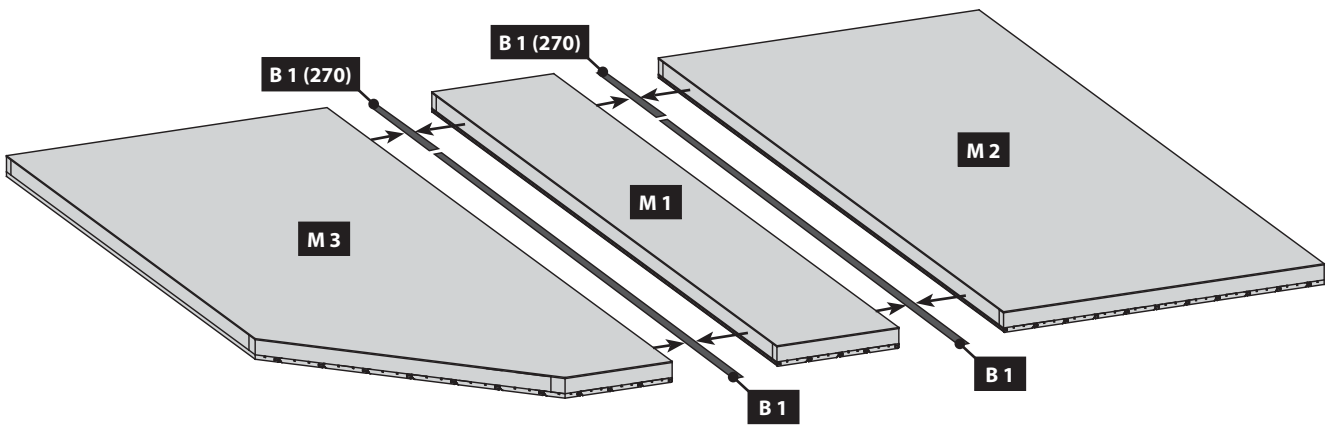
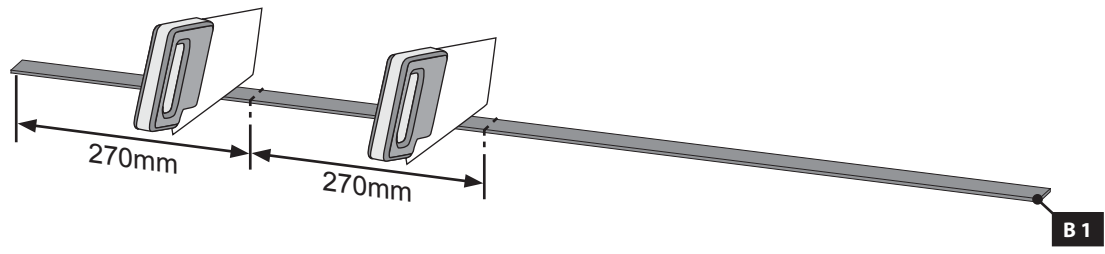

12.1

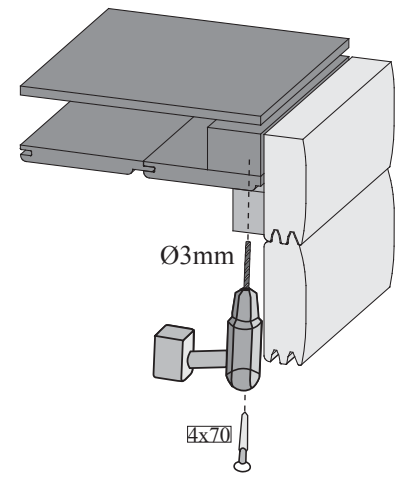

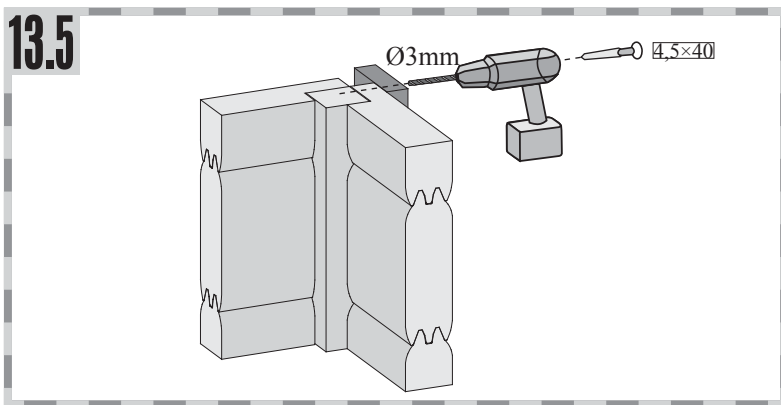
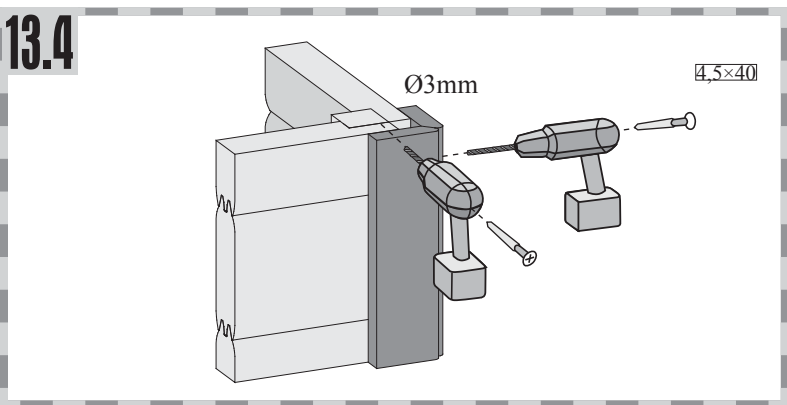
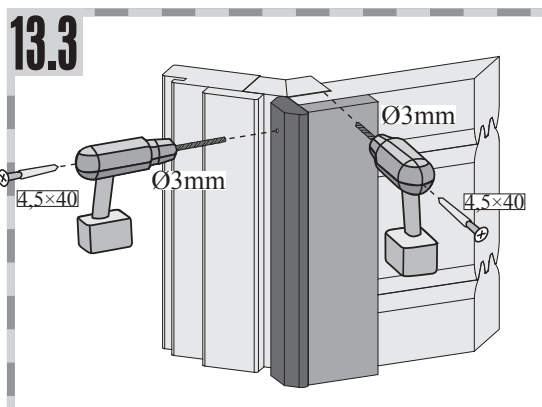
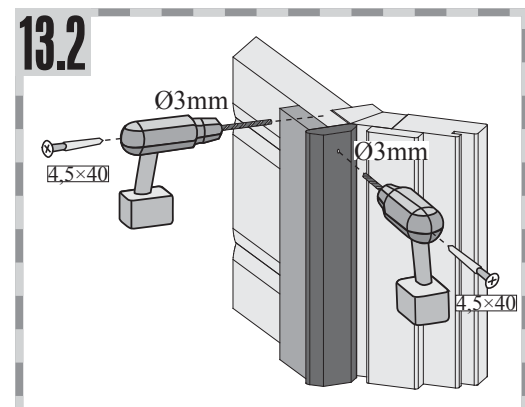
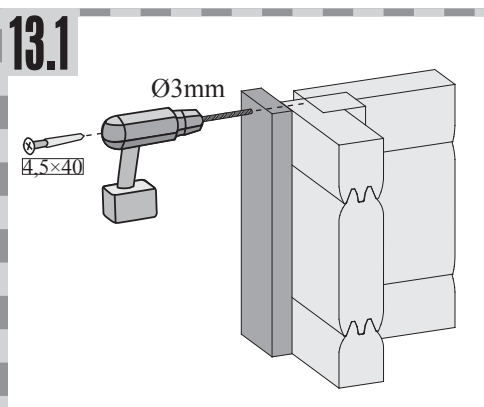
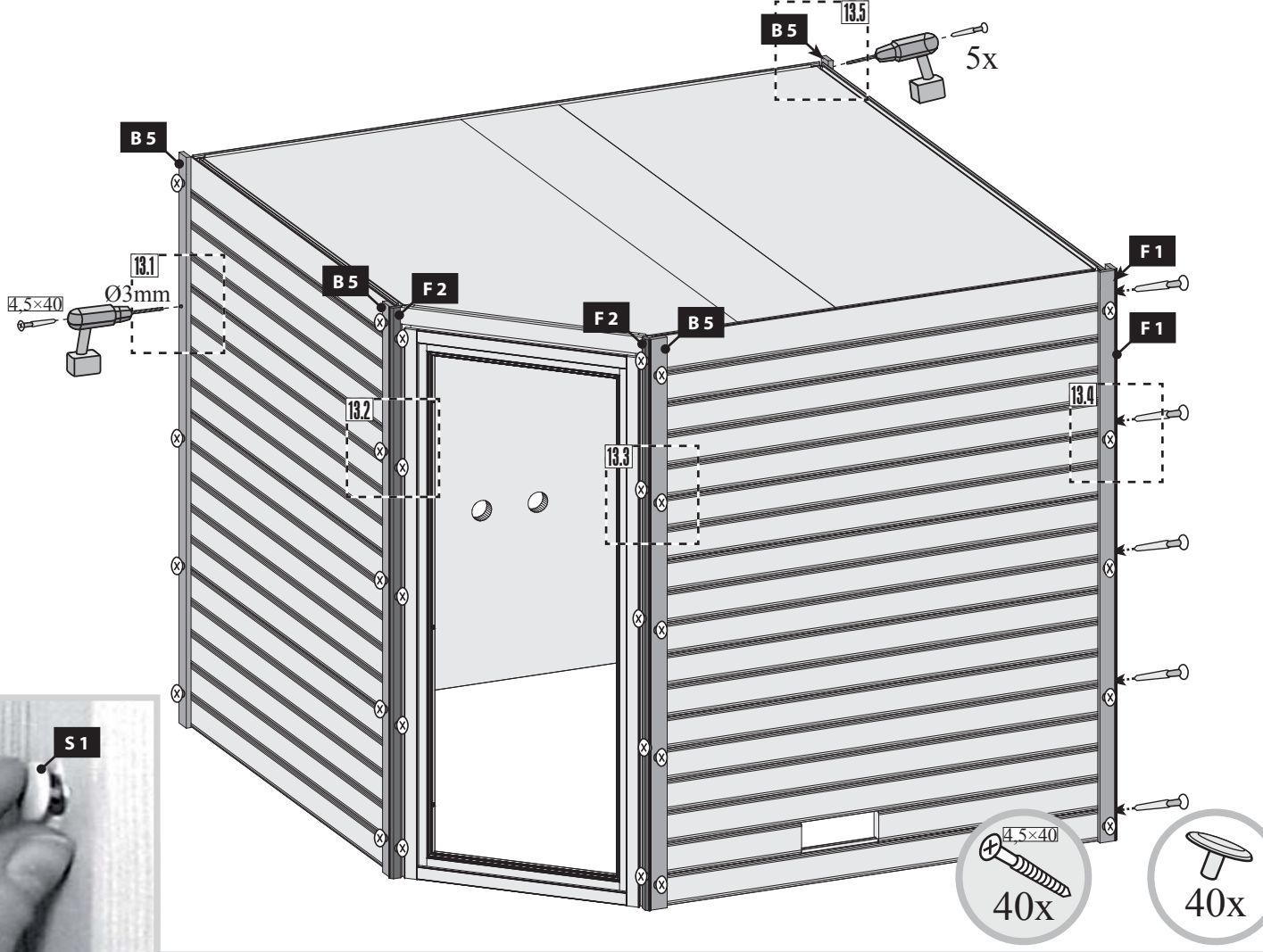

14 2x

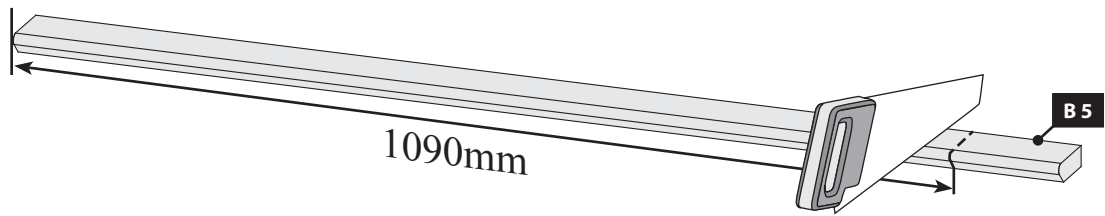

15

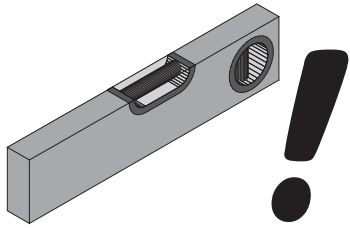

Bündig!  
Affleurement!  
Gelijk!  
Aras!  
Flush!  
Combacia!  
Stejný!

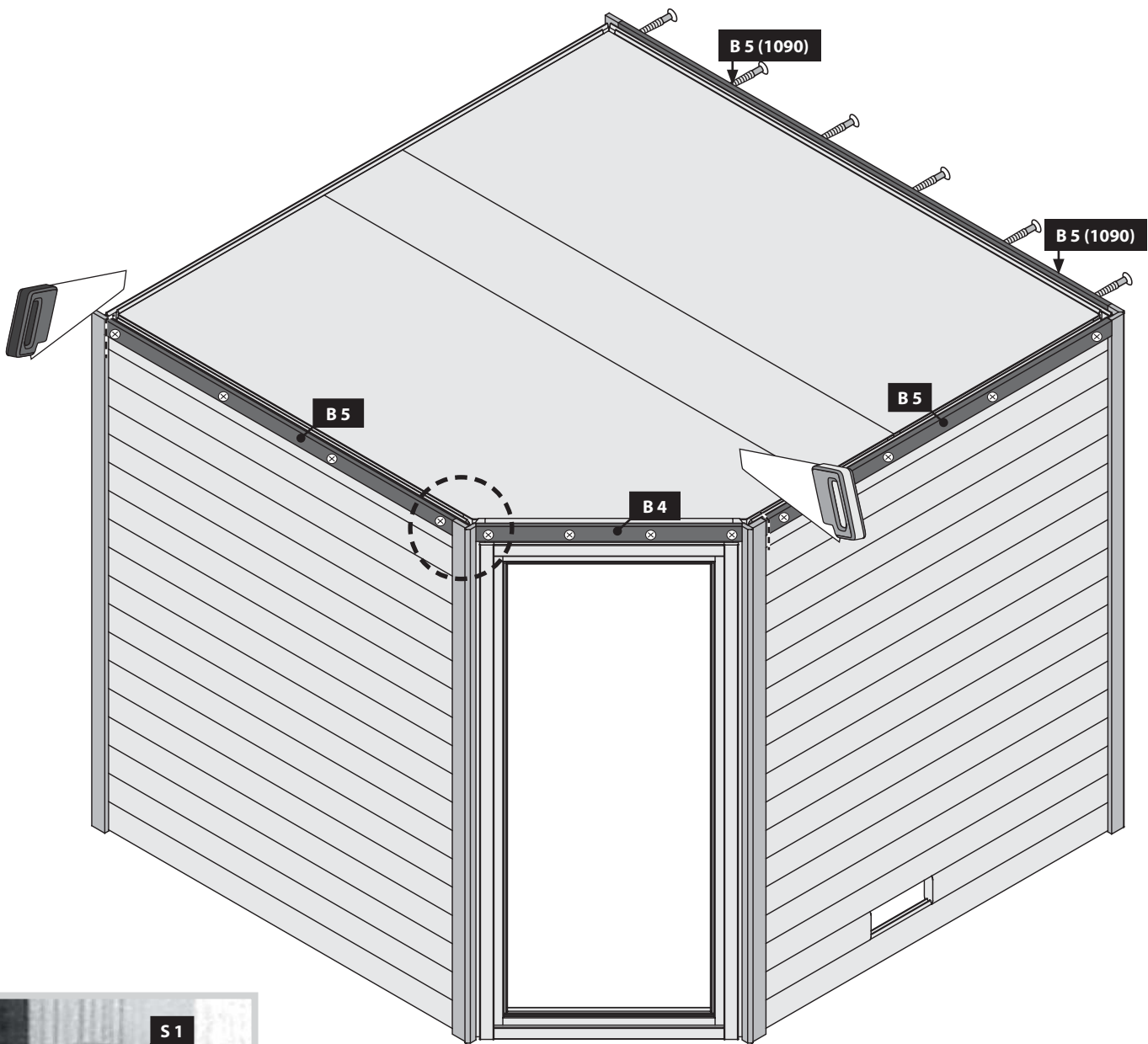
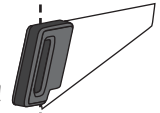

16 2x

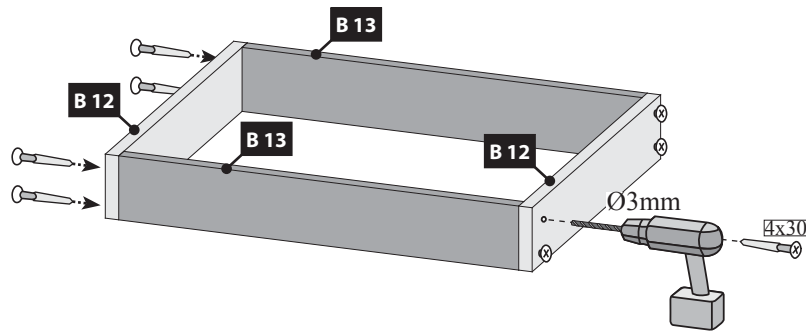

17 a

-  Nur bei 9 kW-Ofen
-  Seulement 9 kW chauffe
-  Only 9 kW heater
-  Slechts 9 kW heater
-  Sólo calentador de 9 kW
-  Solo riscaldamento 9 kW
-  Pouze topné těleso 9 kW

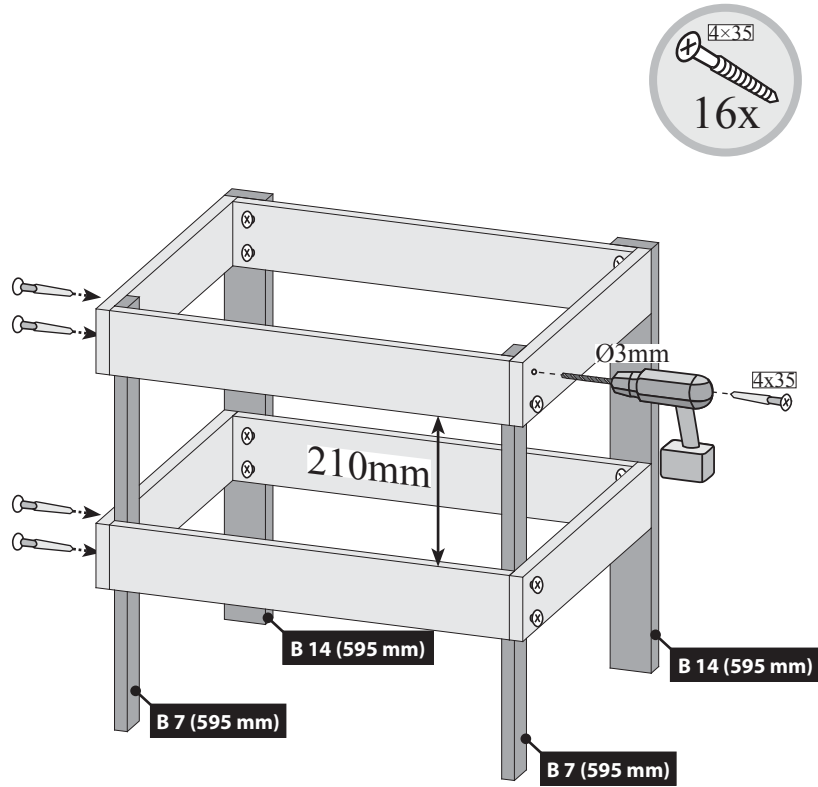
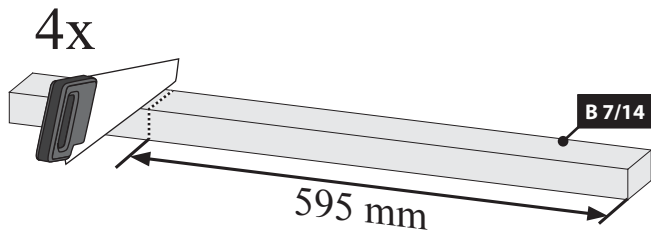

17 b

-  Bei allen anderen Öfen
-  Pour tous les autres fours
-  For all other furnaces
-  Voor alle andere ovens
-  Para todos los otros hornos
-  Per tutti gli altri tipi di forni
-  U všech ostatních pecích

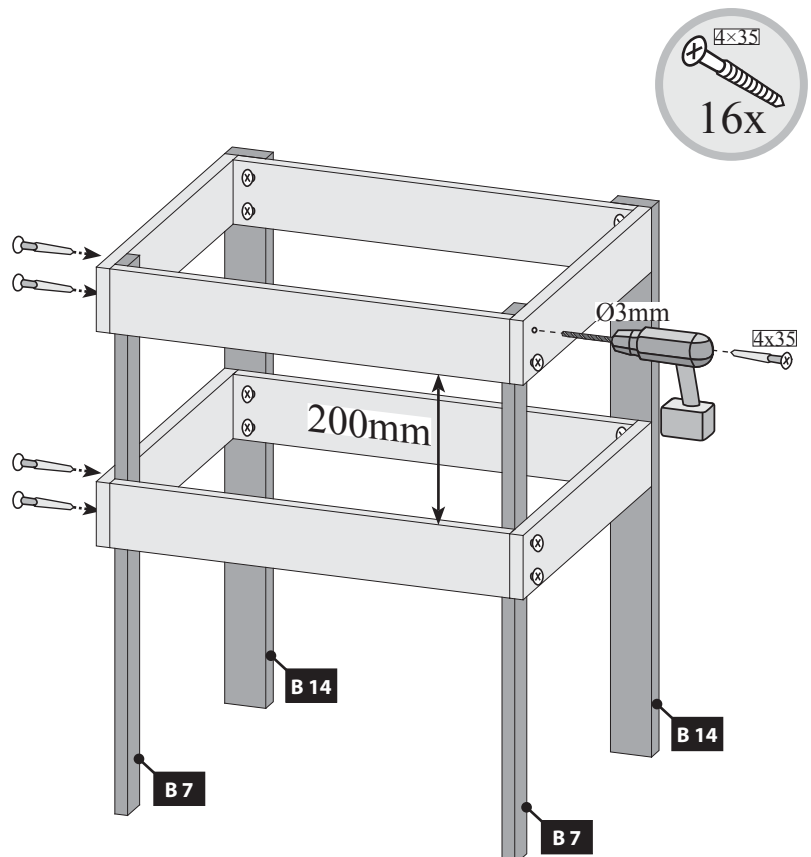

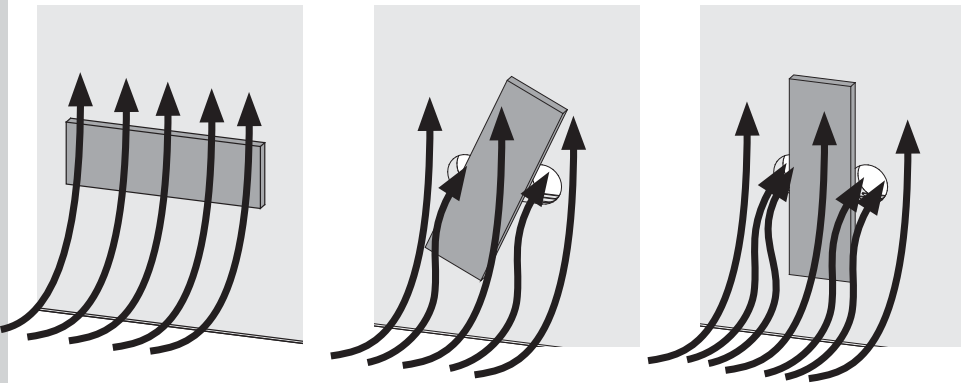
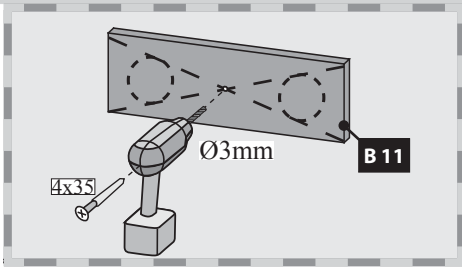
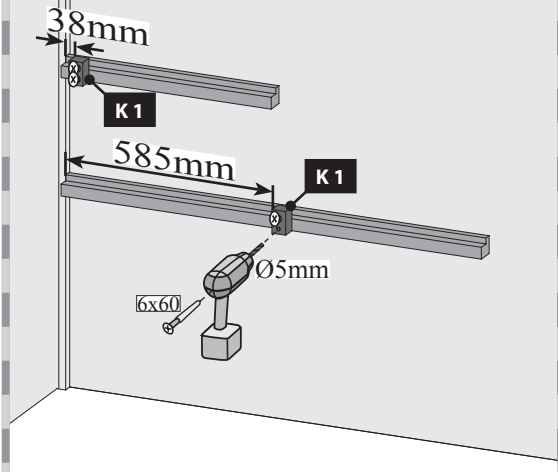
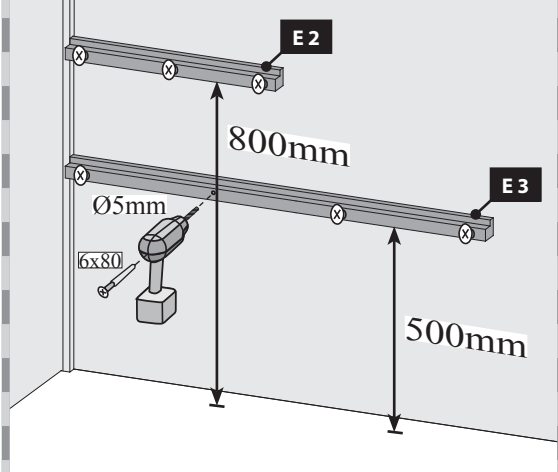
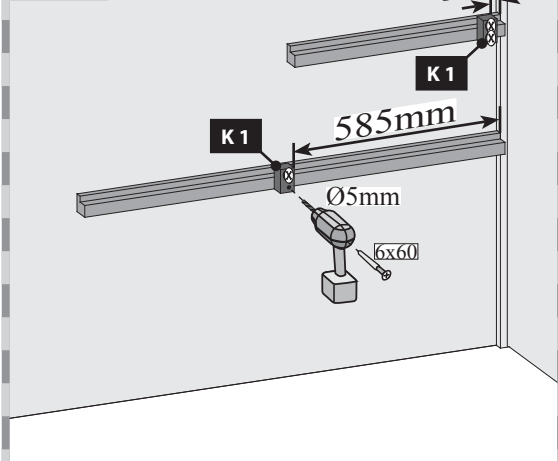
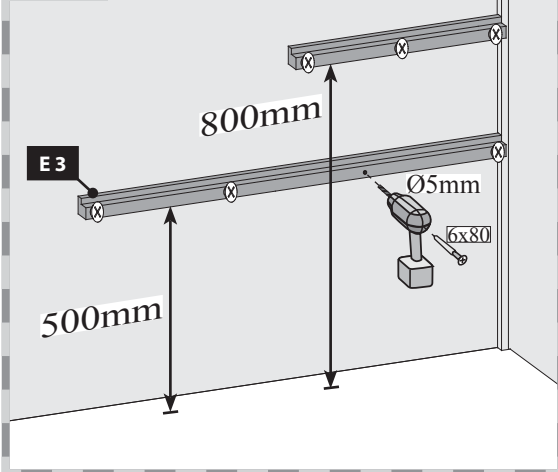
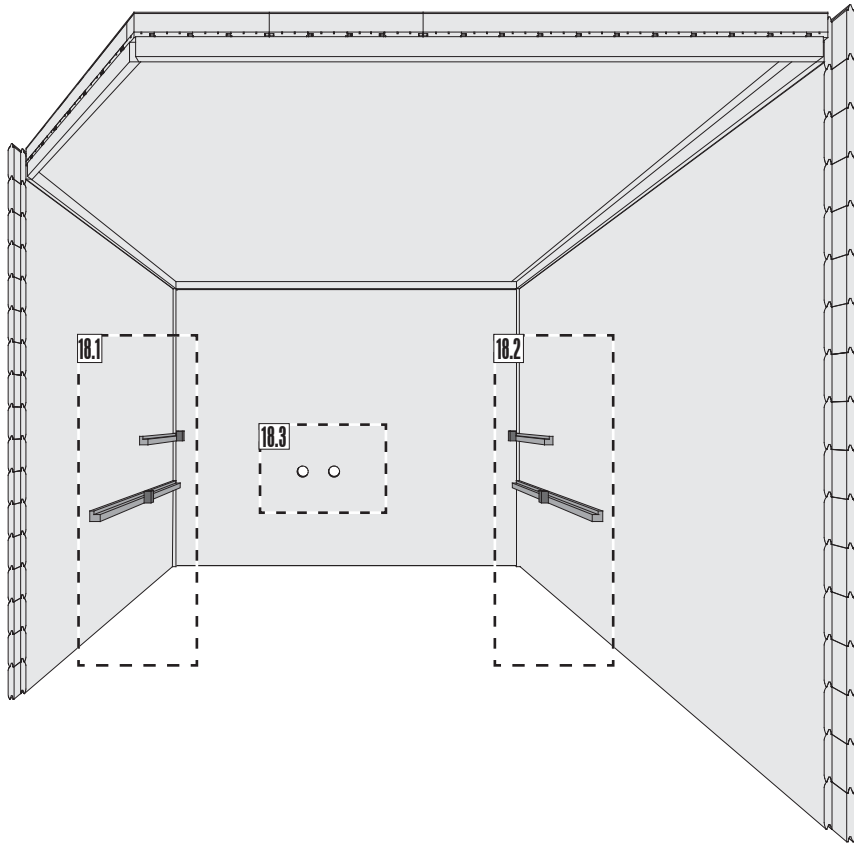

Hier ist die Funktionsweise des Brettes abgebildet. Regeln Sie damit die Abluft nach Ihren eigenen Wünschen.

Ceci représente le mode de fonctionnement de la planche. Avec elle, réglez l'écoulement de l'air selon vos désirs.

This figure shows the functional principle of the board. Regulate the exhaust air according to your own wishes.

Hier is de werking van het plankje afgebeeld. Regel daarmee de luchtafvoer naar eigen wens.

Aquí está representada la forma de funcionamiento de la tabla. Regule con ello el aire de salida según sus propios deseos.

Viene illustrato il principio di funzionamento della tavoletta di regolazione della ventilazione. Con essa si può regolare a piacere la ventilazione.

Zde je zobrazená funkce desky. Regulujte s ní odsávací vzduch dle Vašeho přání.

19

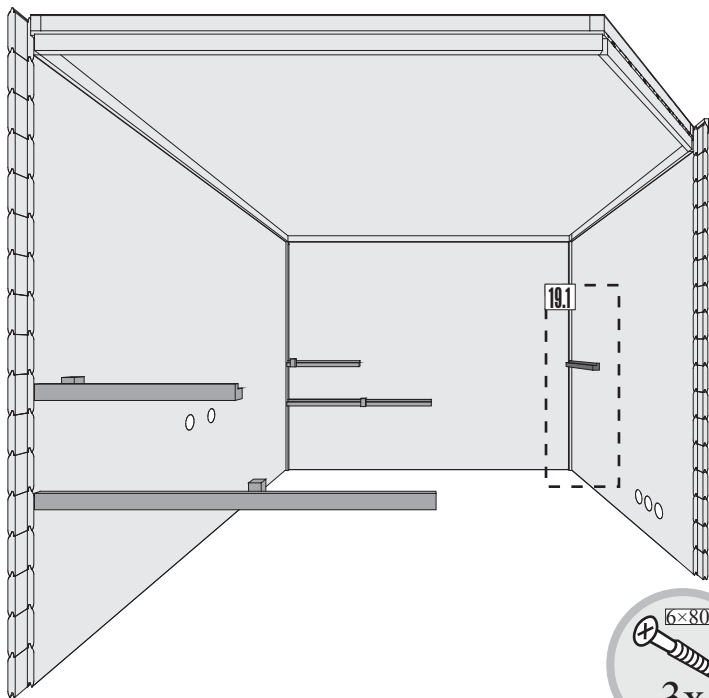
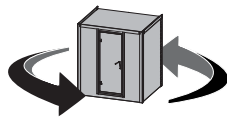

19.1-1

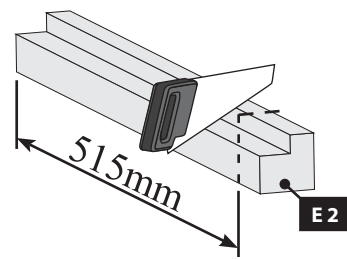

19.1-2

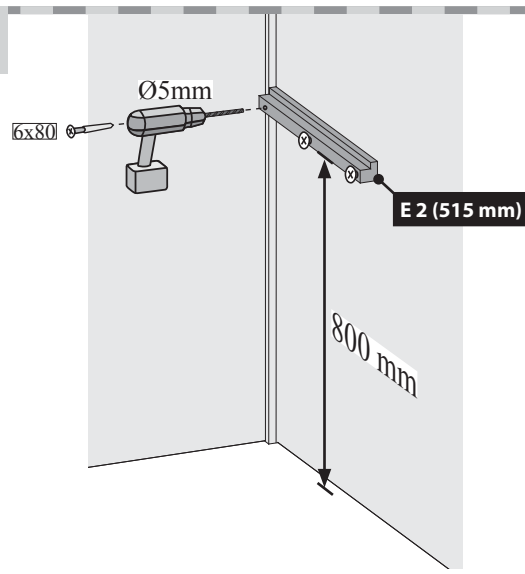

20

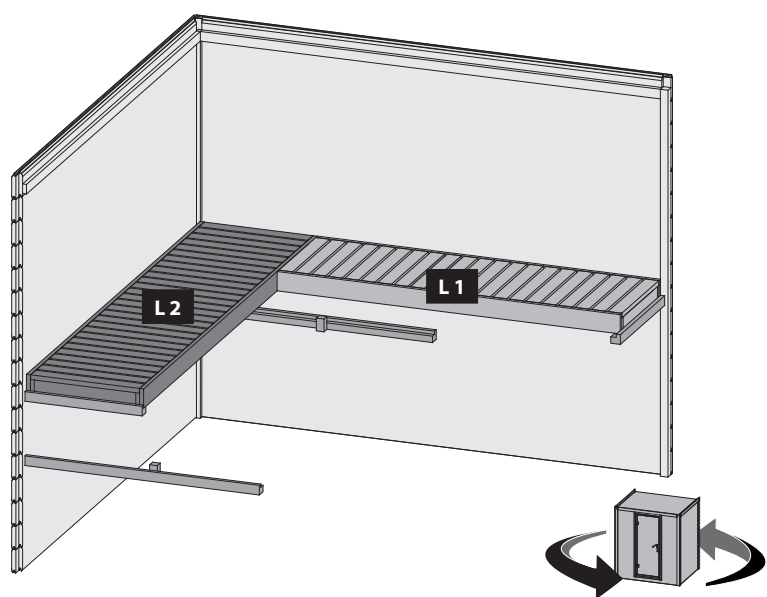

21

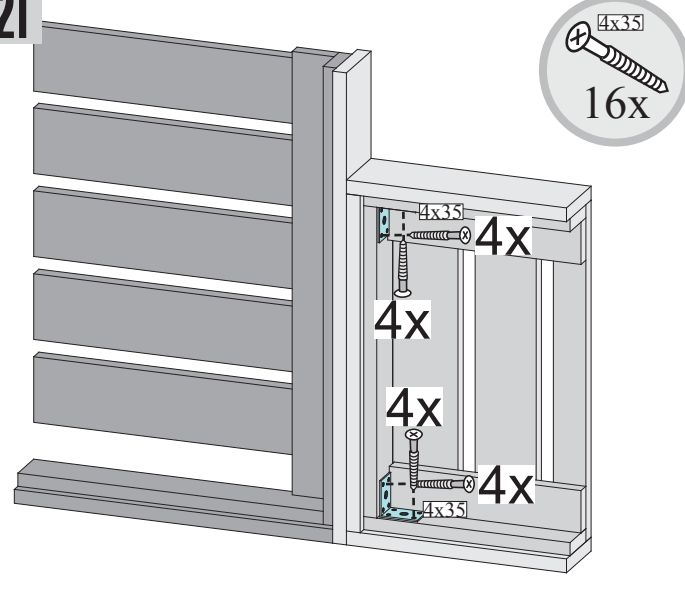

22

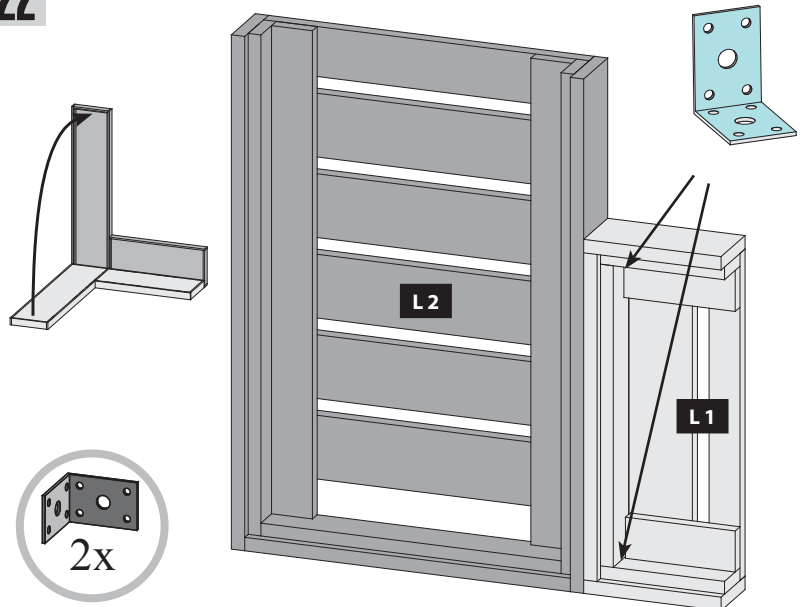

23

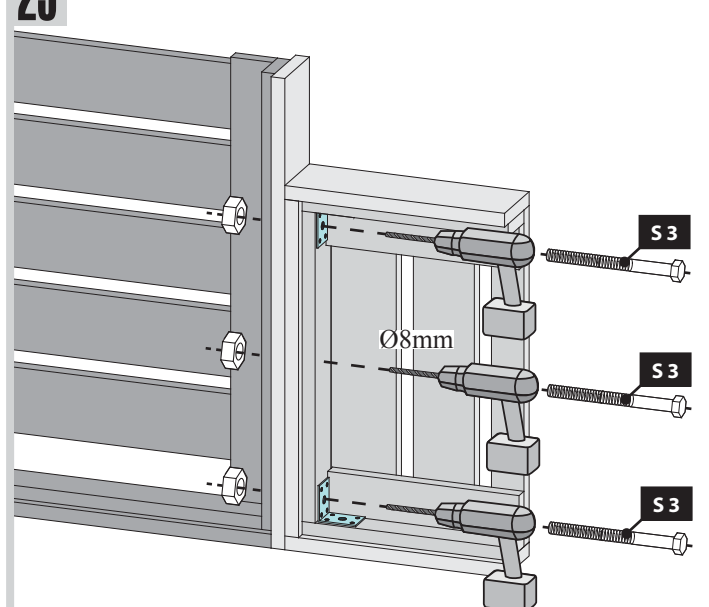

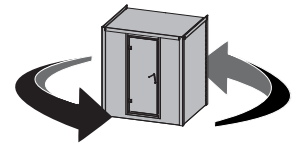

24.1

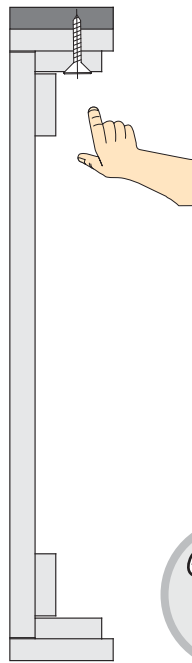
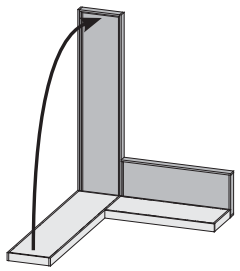
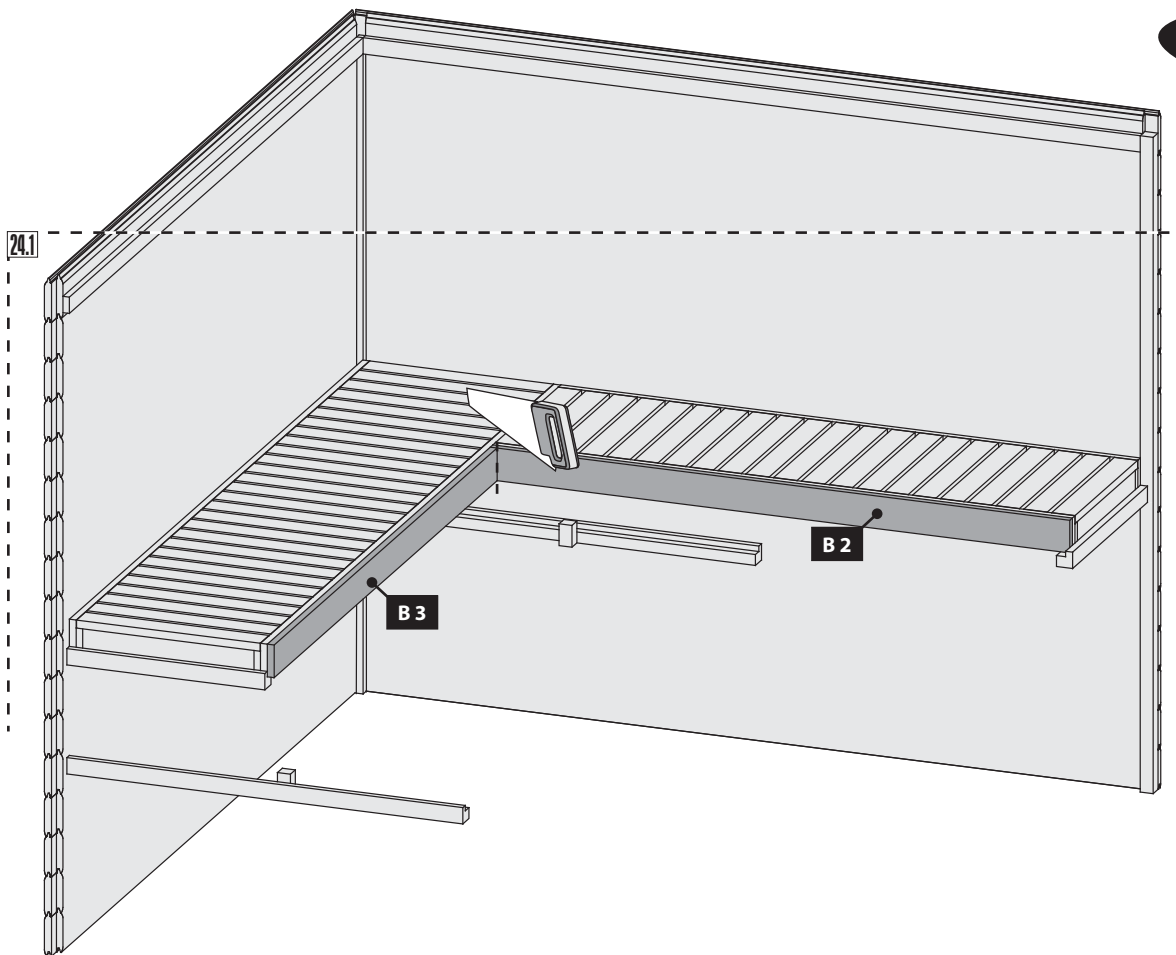



25

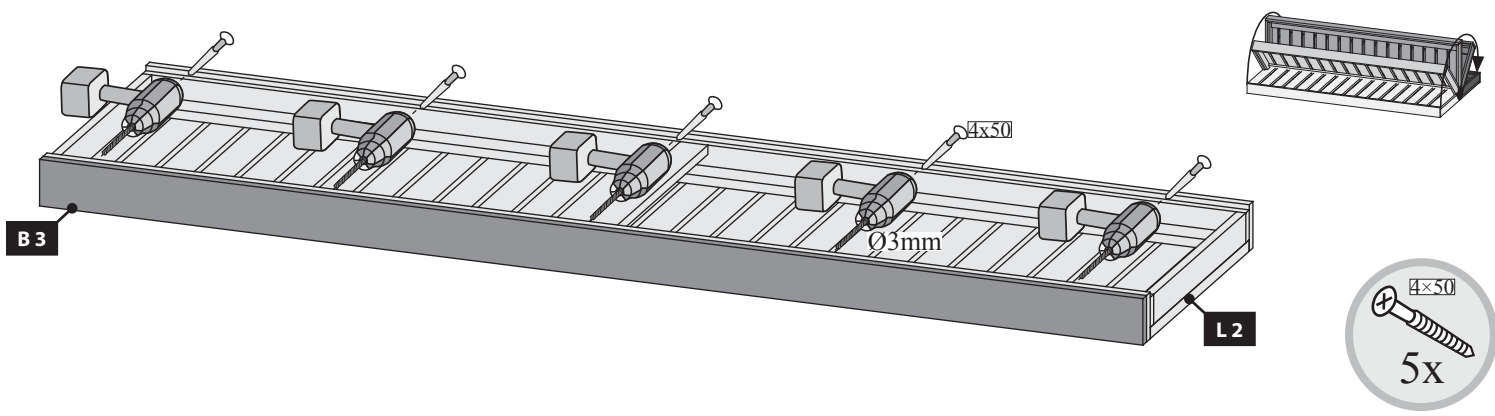

26

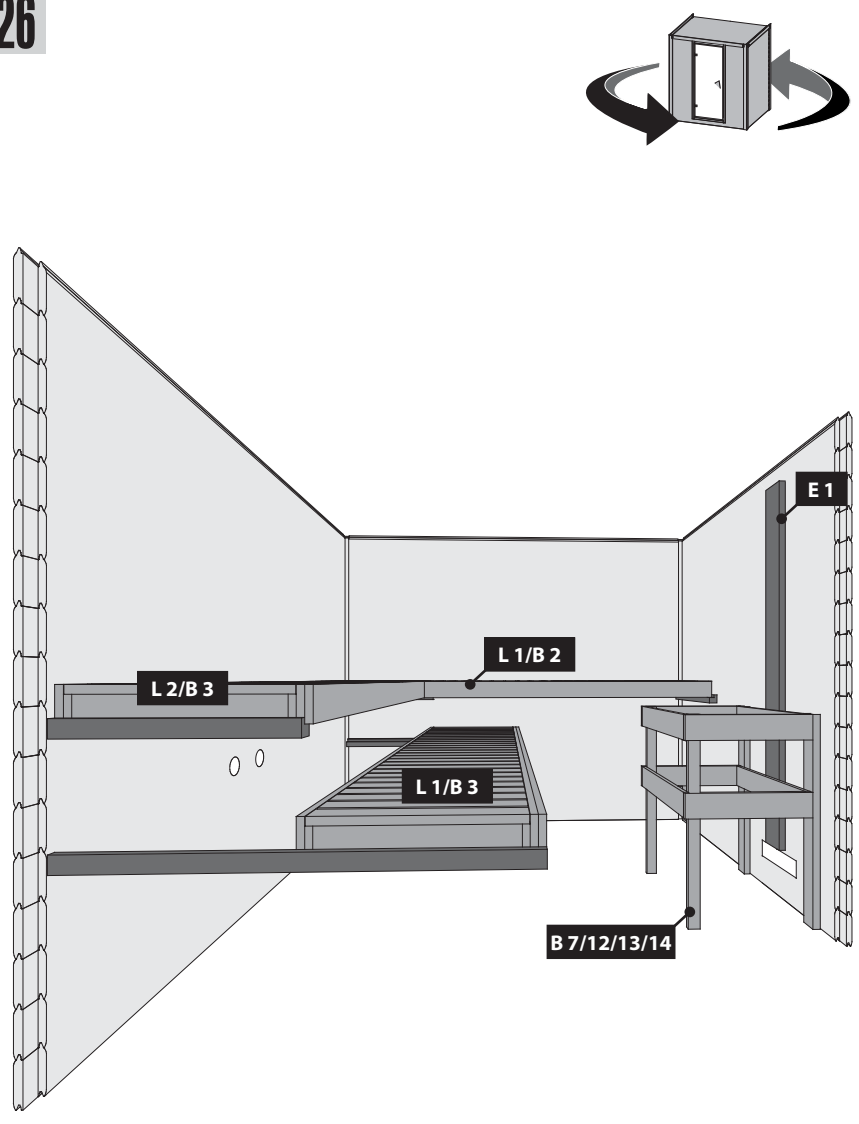

27

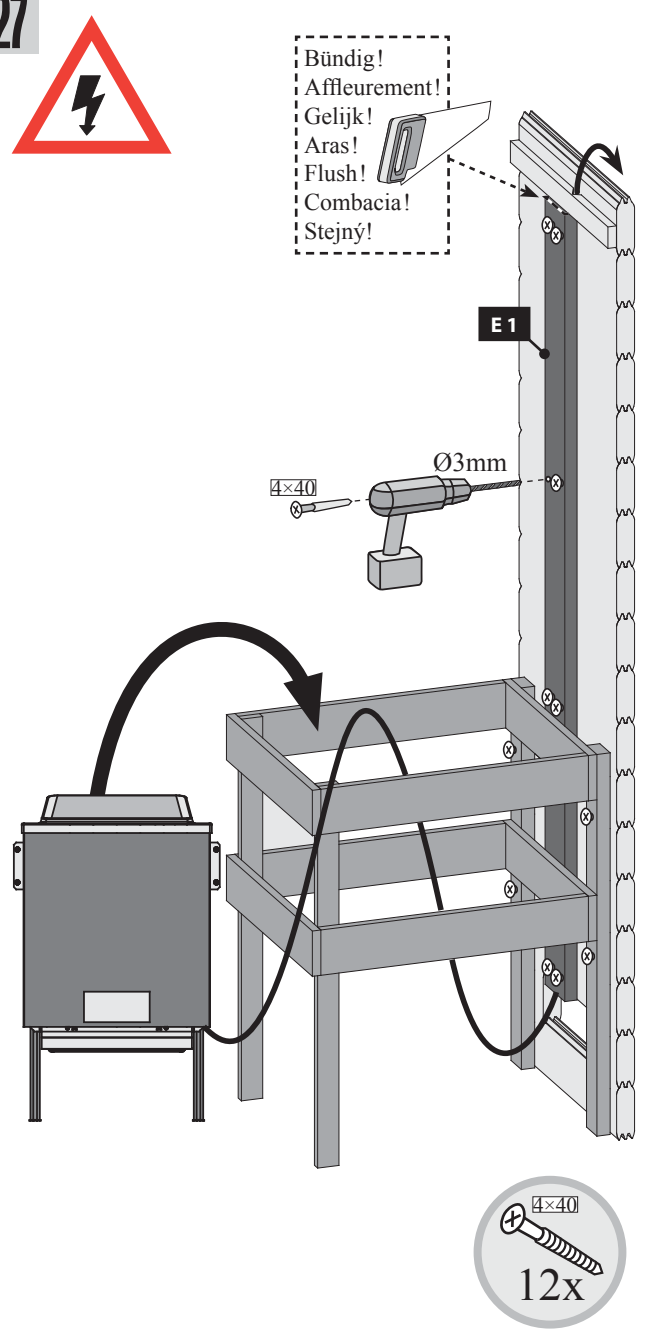

- Einbau Saunatür**
- Sauna deur installatie**
- Sauna Instalace dveře**
- Sauna door installation**
- Instalación de la puerta Sauna**
- Installation de porte Sauna**
- Installazione porta Sauna**

!!!
04
→
...
!!!

70339

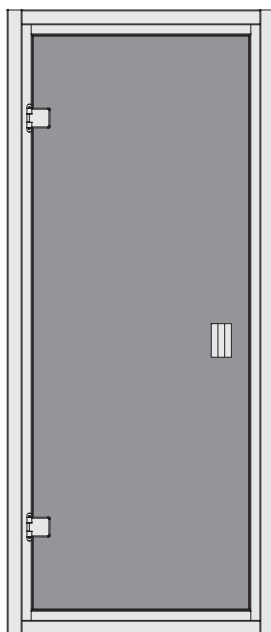



-  **Aufbauanleitung**
-  **Building Instructions**
-  **notice de montage**
-  **montagehandleiding**
-  **Montagevejledning**
-  **Instrucciones de construcción**
-  **Istruzioni per il montaggio**
-  **Montážní návod**
-  **Navodila za sestavljanje**

 Vergleichen Sie zuerst die Material-liste mit Ihrem Paketinhalt! Bitte haben Sie Verständnis, dass Beanstandungen nur im nicht aufgebauten Zustand bearbeitet werden können!

 Vergelijk eerst de lijst van materialen met de inhoud van uw pakket! Reclamaties kunnen alleen in behandeling worden genomen zolang de onderdelen nog niet zijn gemonteerd!

 Confrontate questa distinta materiali prima con il contenuto del pacchetto! Vi preghiamo di comprendere che eventuali reclami possono essere accolti solo prima del montaggio!

 First compare the list of materials with your package contents! Please understand that complaints can be processed in the non-built status only!

 Start med at kontrollere materialelisten med indholdet af den leverede pakke! Vi gør venligst opmærksom på at reklamationer kun kan behandles for materialer som ikke er blevet bearbejdet!

 Nejprve překontrolujte obsah balení podle materiálového listu! Mějte pochopení pro to, že případnou reklamaci se můžeme zabývat pouze tehdy, když díly nebudou smontované! Za pomoci tohoto seznamu můžete jednotlivé díly přiřadit k montážnímu návodu.

 Commencez par comparer la liste du matériel avec le contenu de votre paquet! Sachez que nous traitons uniquement les réclamations concernant le matériel à l'état non monté!

 En primer lugar, compare la lista de material con el contenido del paquete. Rogamos entienda que las reclamaciones sólo pueden ser tramitadas antes de montar el objeto!

 Najprej primerajte seznam materialov z vsebino vašega paketa! Upoštevajte, da lahko pritožbe obravnavamo le v nesestavljenem stanju!

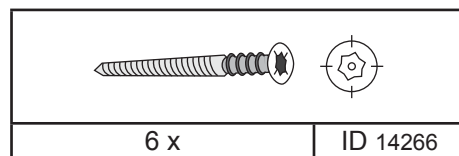
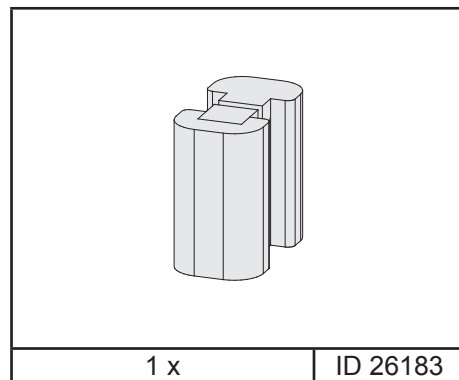
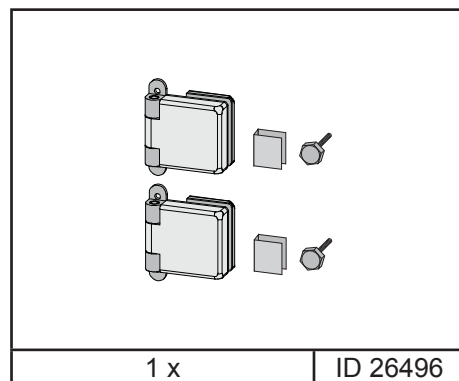
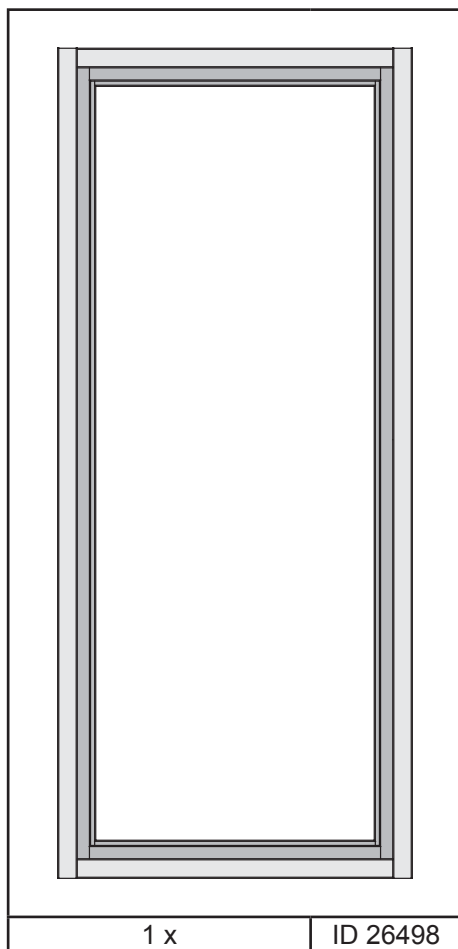
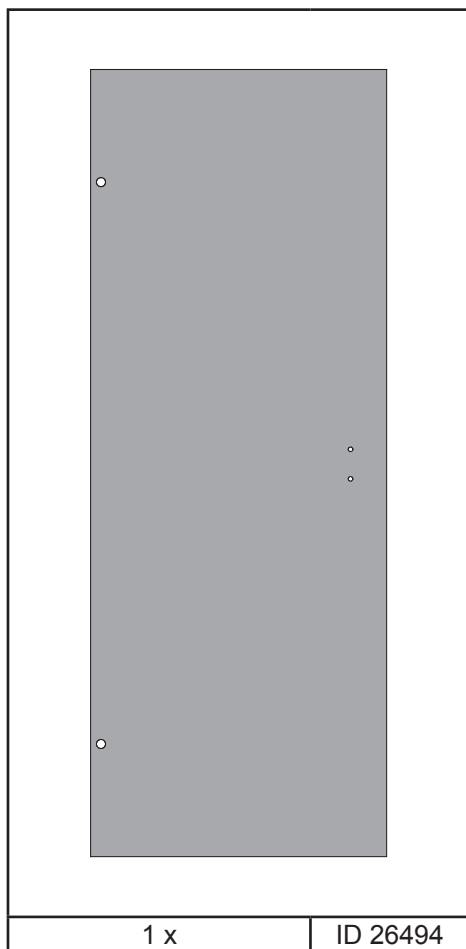
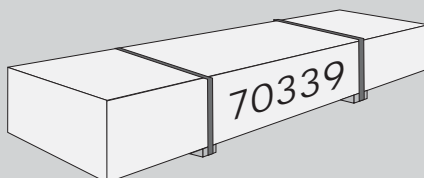





 Bitte beachten Sie, dass es sich bei einem Spontanbruch infolge von Nickelsulfideinschlüssen um Glasbrüche handelt, die nicht auf Verarbeitungsfehler basieren und somit nicht durch den Hersteller und dem Verarbeiter zu vertreten sind. Der Spontanbruch ist als hinzunehmendes Allgemeinrisiko anzusehen.

Bitte haben Sie Verständnis, dass wir eine Nachlieferung nur gegen Berechnung ausführen können.

 Upoštevajte, da je spontano lomljenje zaradi vključkov nikljevega sulfida lomljenje stekla, ki ni posledica napak pri obdelavi, zato zanj proizvajalec in predelovalec nista odgovorna. Samodejni lom stekla je treba obravnavati kot splošno tveganje, ki ga je treba sprejeti.

Prosimo, upoštevajte, da lahko naknadno dobavo opravimo le proti plačilu.

-  Einbau Glastür
-  Installation of glass door
-  Montage porte en verre
-  Montage van de glazen deur
-  Installationsglasdør

-  Montaje de la puerta de cristal
-  Installazione portello di vetro
-  Sauna Instalace dveře
-  Vgradnja steklenih vrat

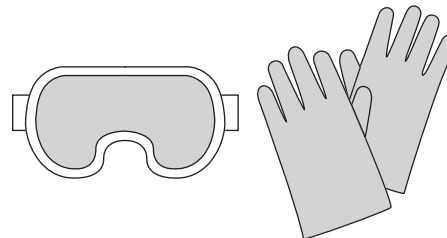

01

-  Tür in den Rahmen legen
-  Put the door in the frame
-  Mettez la porte dans le cadre
-  Plaats de deur in het frame
-  Sæt døren i rammen
-  Pon la puerta en el marco
-  Metti la porta nel telaio
-  Vložte dveře do rámu
-  Vrata namestite v okvir

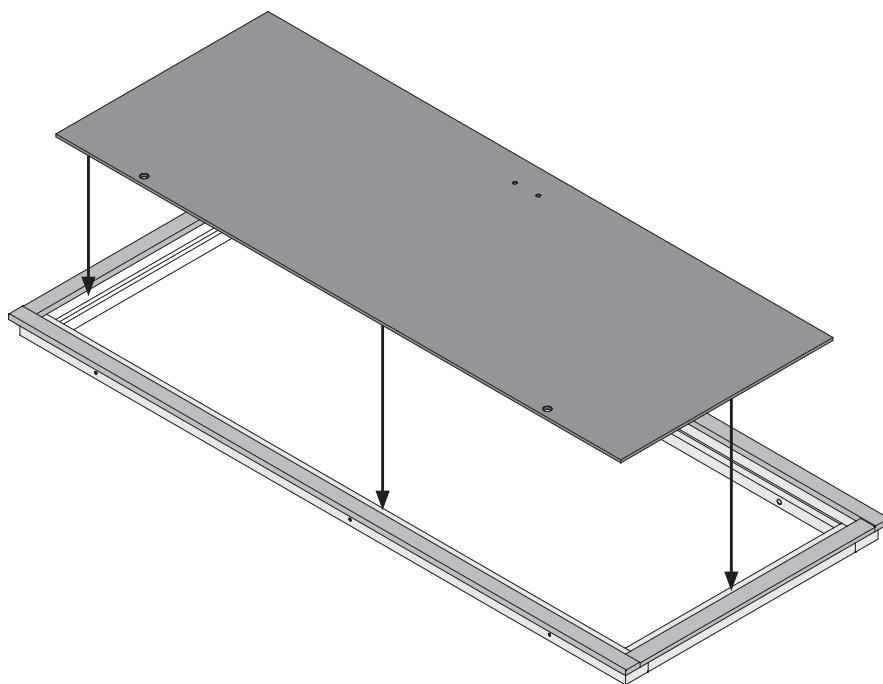

02

-  Tür im Rahmen ausrichten
-  Center the door in the frame
-  Aligner la porte dans le cadre
-  Lijn de deur in het frame uit
-  Juster døren i rammen
-  Alinea la puerta en el marco
-  Allinea la porta nella cornice
-  Zarovnejte dveře do rámu
-  Poravnajte vrata v okvir

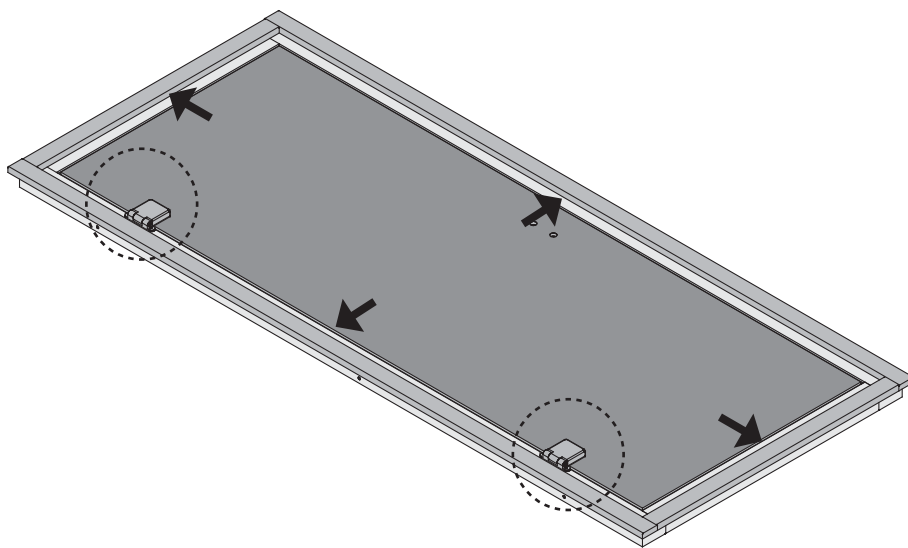

1.

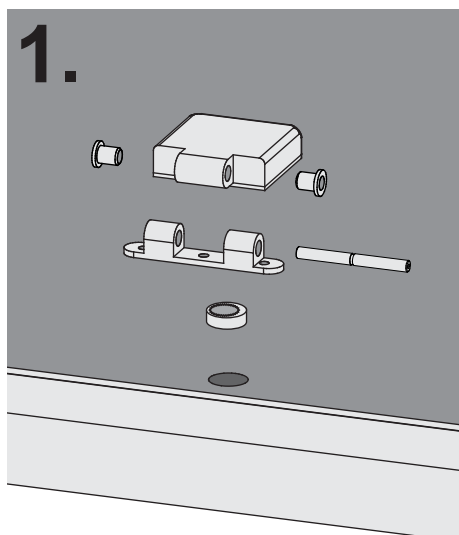

2.

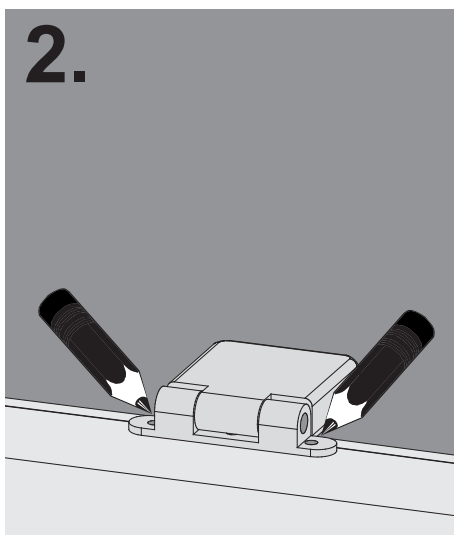



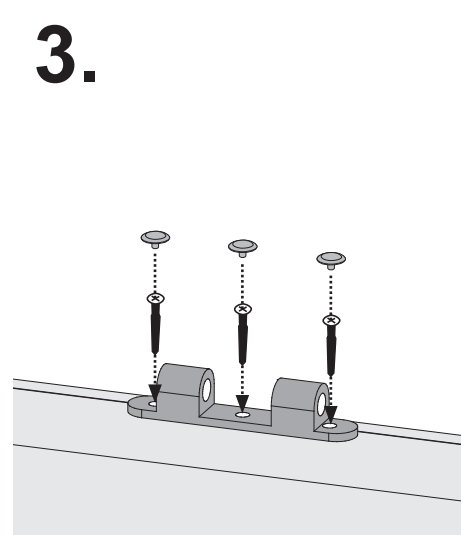

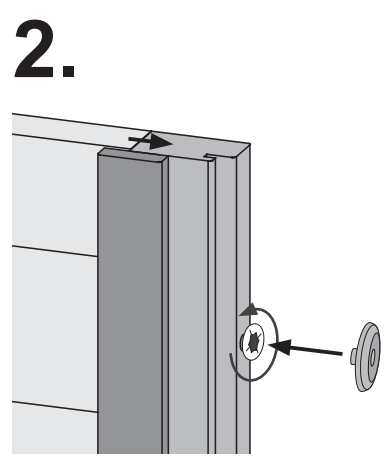
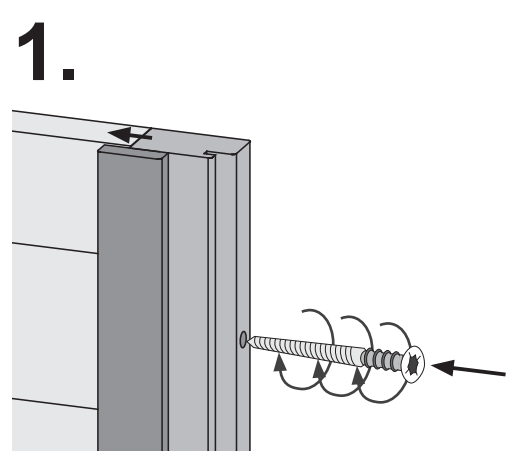
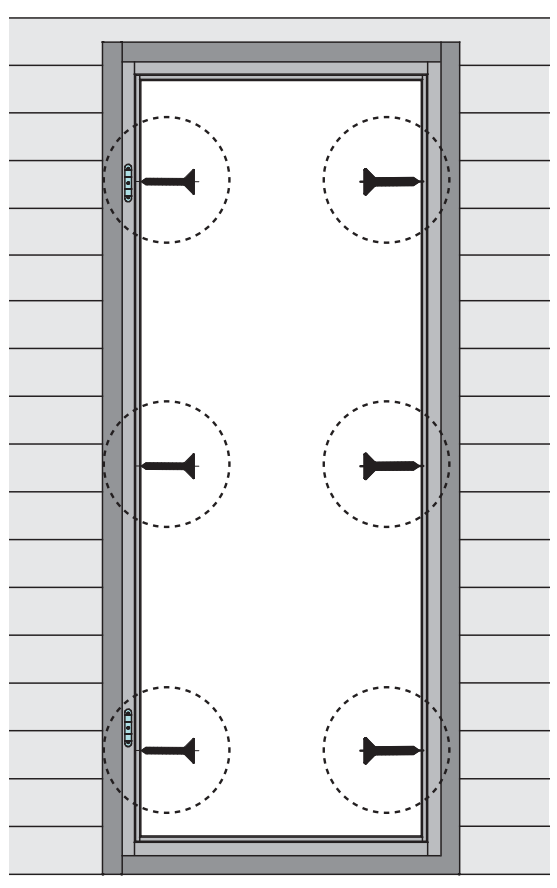
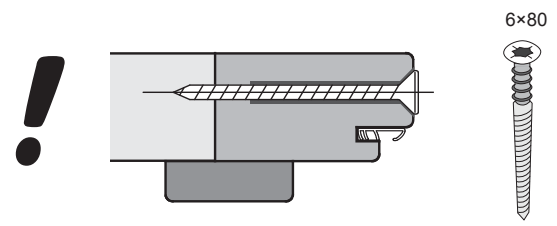
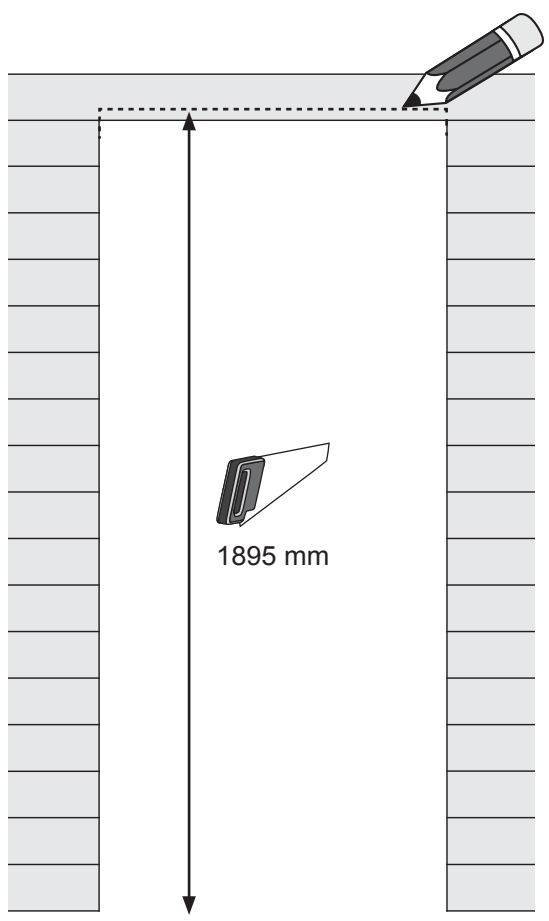
3.





-  Einbau Glastür
-  Installation of glass door
-  Montage porte en verre
-  Montage van de glazen deur
-  Installationsglasdør



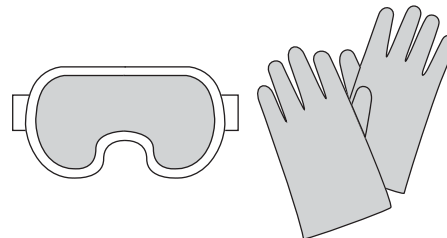



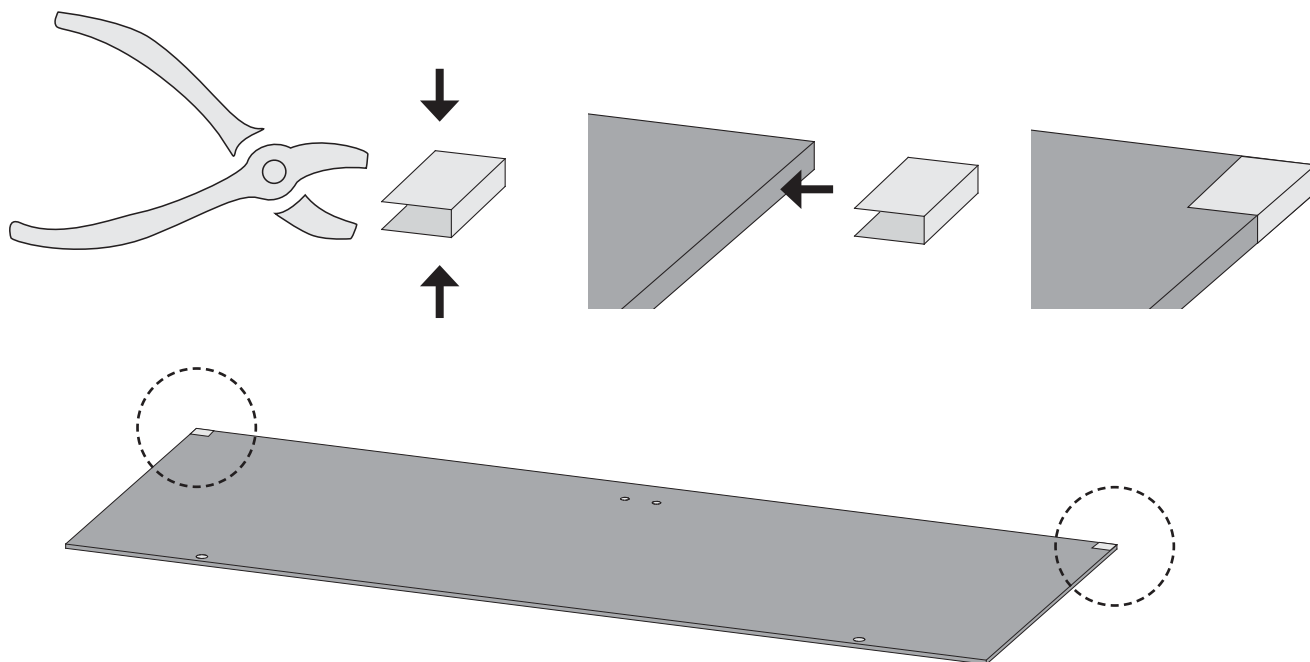

-  Montaje de la puerta de cristal
-  Installazione portello di vetro
-  Sauna Instalace dveře
-  Vgradnja steklenih vrat



04





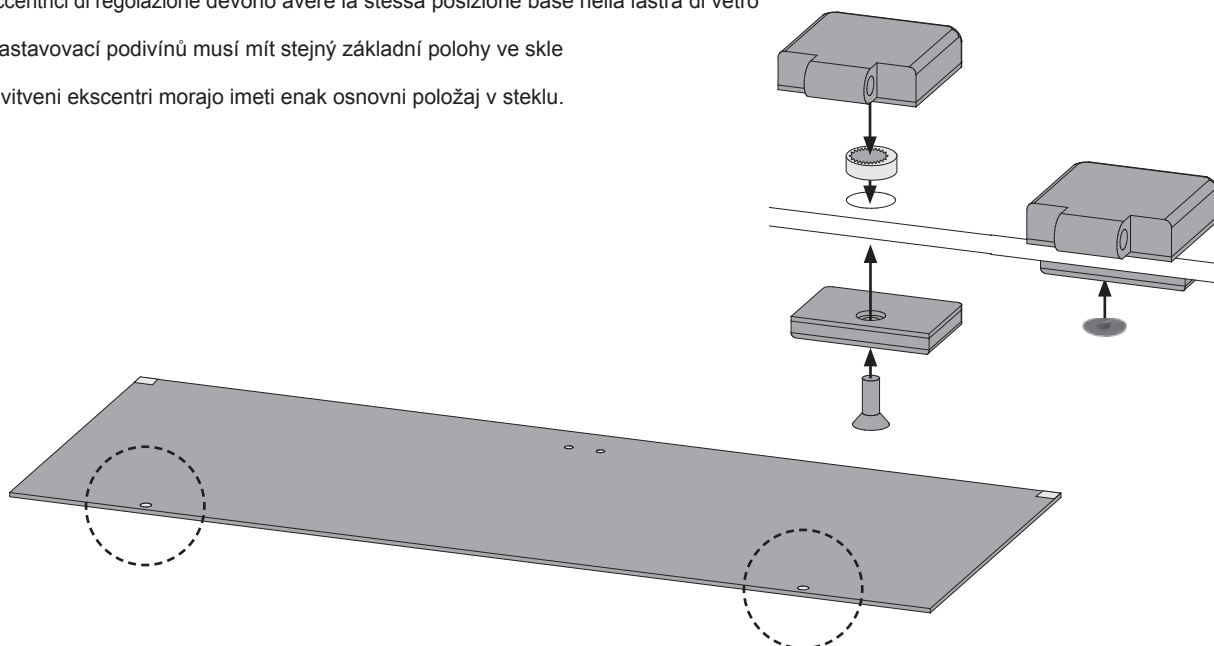

05

-  Alle Verstell-Excenter müssen in der Glasscheibe die gleiche Grundstellung haben
-  All adjustable eccentrics must have the same basic adjustment in the glass panel
-  Tous les excentriques de positionnement doivent avoir la même position de base dans la vitre
-  Alle excentrische verstelelementen moeten in dezelfde stand in de glasplaat worden geplaatst
-  Alle justeringsexcentricer skal have samme grundlæggende position i glasruden
-  Todos los excéntricos regulables tienen que tener la misma posición base en la hoja de cristal
-  Tutti gli eccentrici di regolazione devono avere la stessa posizione base nella lastra di vetro
-  všechny nastavovací podivínů musí mít stejný základní polohy ve skle
-  Vsi nastavitveni ekscentri morajo imeti enak osnovni položaj v steklu.



-  Einbau Glastür
-  Installation of glass door
-  Montage porte en verre
-  Montage van de glazen deur
-  Installationsglasdør



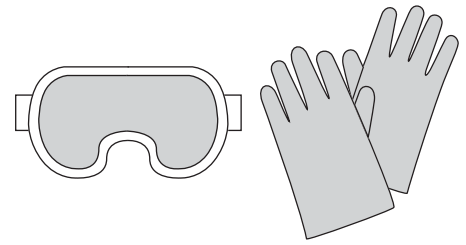

-  Montaje de la puerta de cristal
-  Installazione portello di vetro
-  Sauna Instalace dveře
-  Vgradnja steklenih vrat

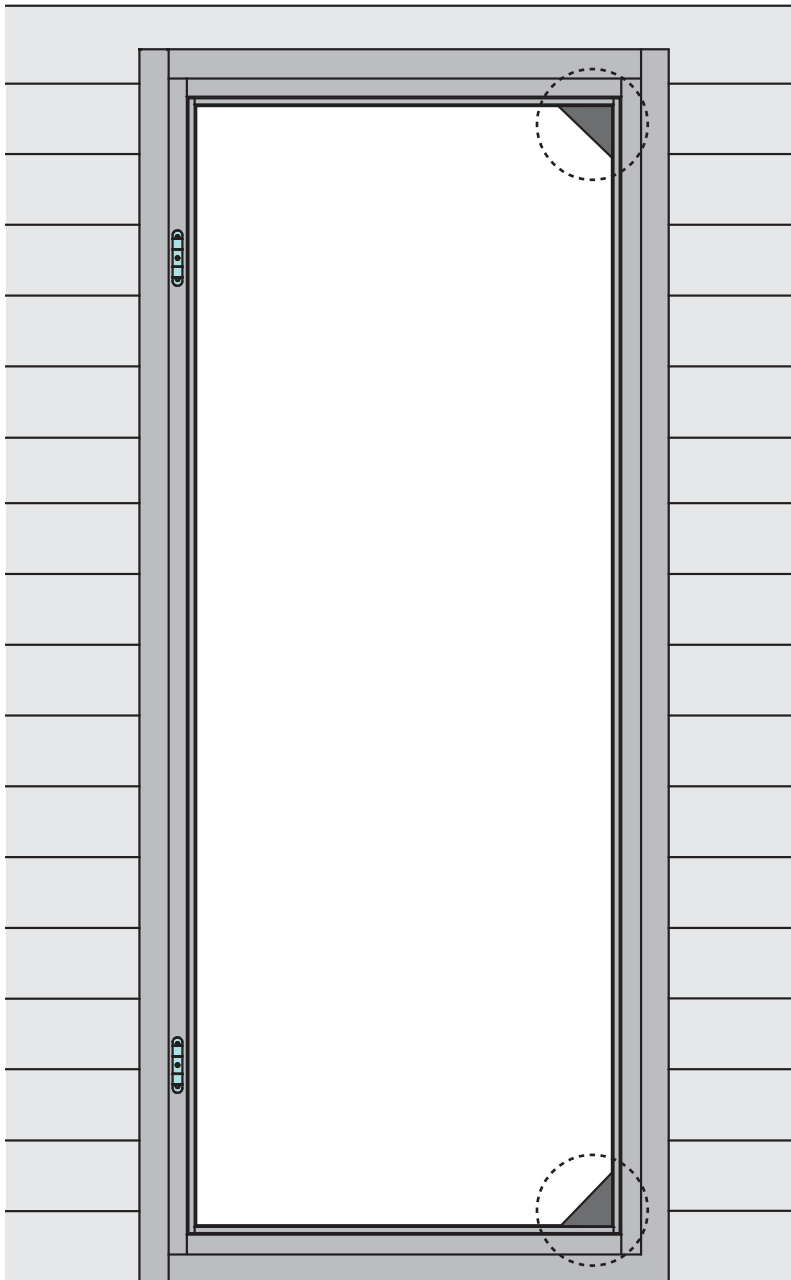

06



-  Einbau Glastür
-  Installation of glass door
-  Montage porte en verre
-  Montage van de glazen deur
-  Installationsglasdør

-  Montaje de la puerta de cristal
-  Installazione portello di vetro
-  Sauna Instalace dveře
-  Vgradnja steklenih vrat

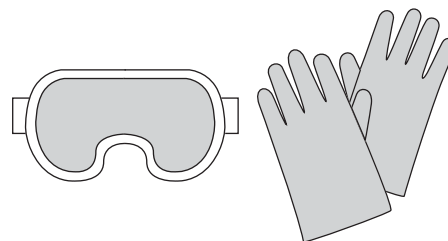

07

- |   |   |
|---|---|
| <ul style="list-style-type: none"> <li> Alle Verstell-Excenter müssen in der Glasscheibe die gleiche Grundstellung haben</li> <li> All adjustable eccentrics must have the same basic adjustment in the glass panel</li> <li> Tous les excenteurs de positionnement doivent avoir la même position de base dans la vitre</li> <li> Alle excentrische verstelelementen moeten in dezelfde stand in de glasplaat worden geplaatst</li> <li> Alle justeringsexcentricer skal have samme grundlæggende position i glasruden</li> </ul> | <ul style="list-style-type: none"> <li> Todos los excéntricos regulables tienen que tener la misma posición base en la hoja de cristal</li> <li> Tutti gli eccentrici di regolazione devono avere la stessa posizione base nella lastra di vetro</li> <li> Šechny nastavovací podivínů musí mít stejný základní polohy ve skle</li> <li> Vsi nastavitveni ekscentri morajo imeti imeti enak osnovni položaj v steklu</li> </ul> |
|---|---|

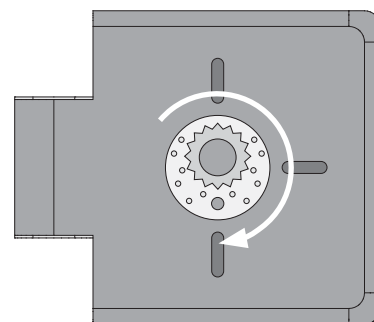
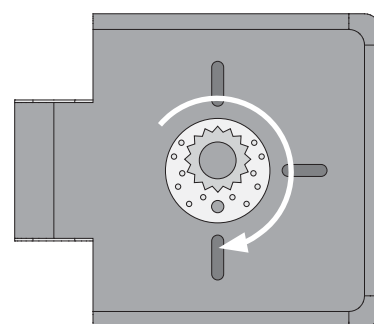
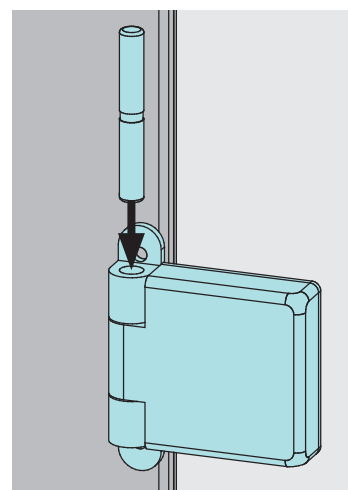
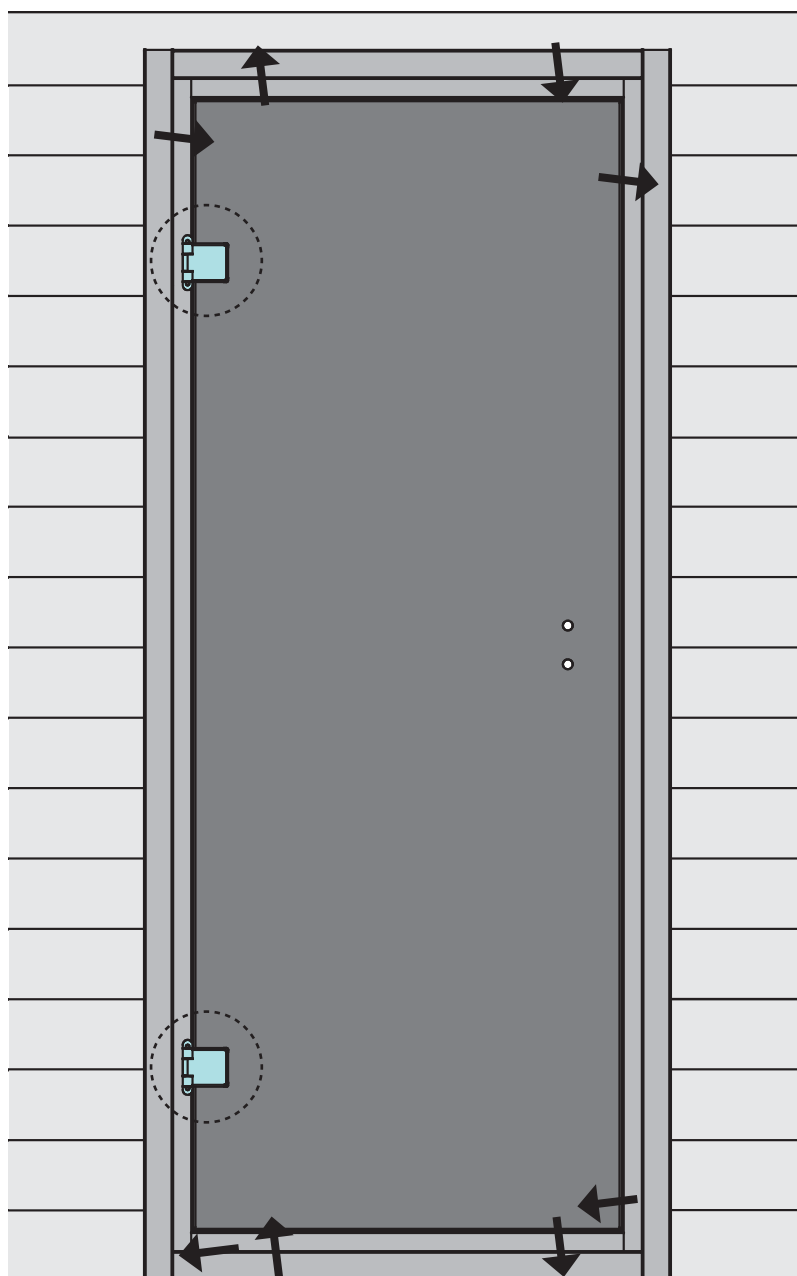



1.

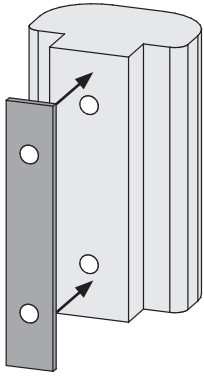

2.

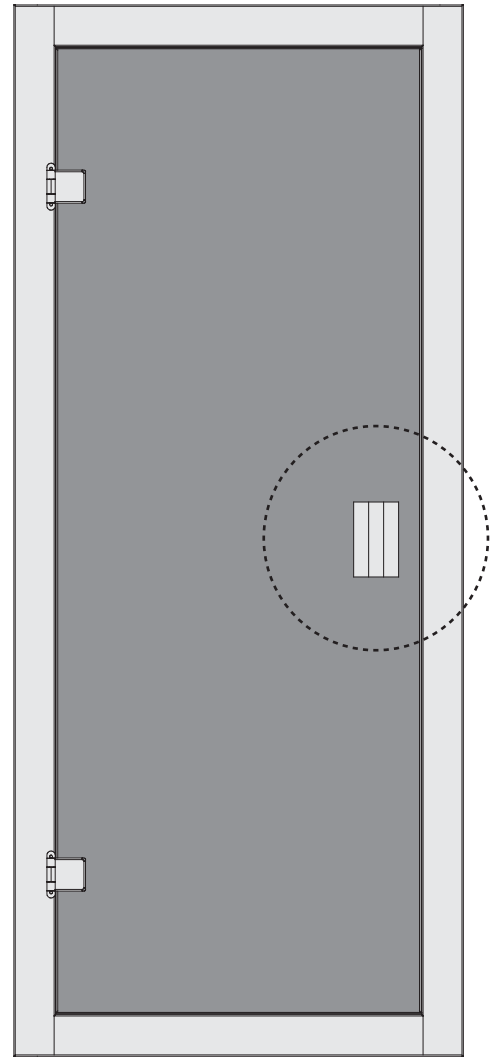
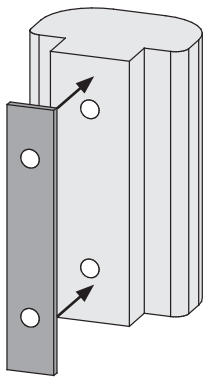

3.

