

ASSEMBLY INSTRUCTION

WF304431/WF304433



WF304432/WF304434

TIPS

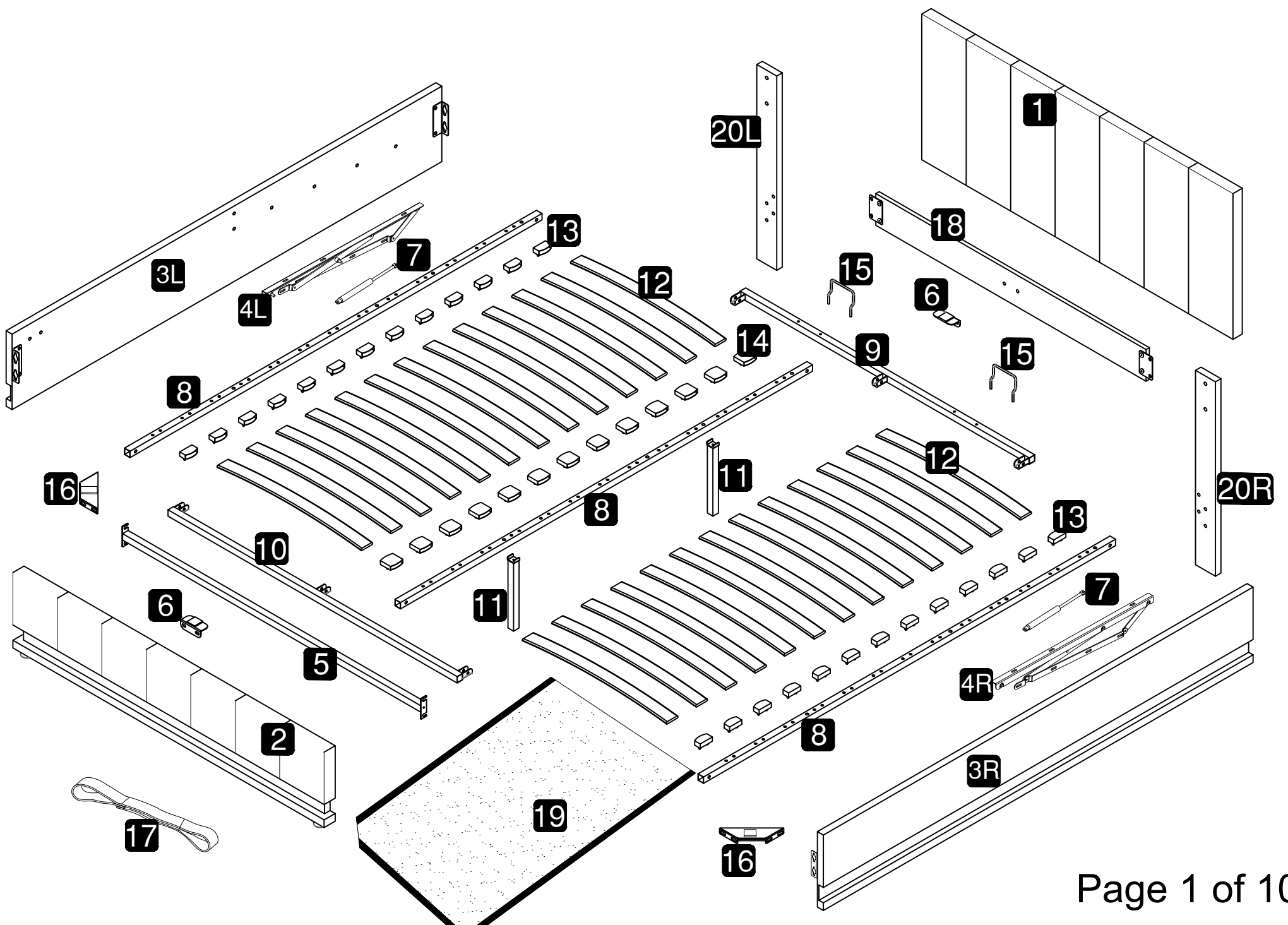
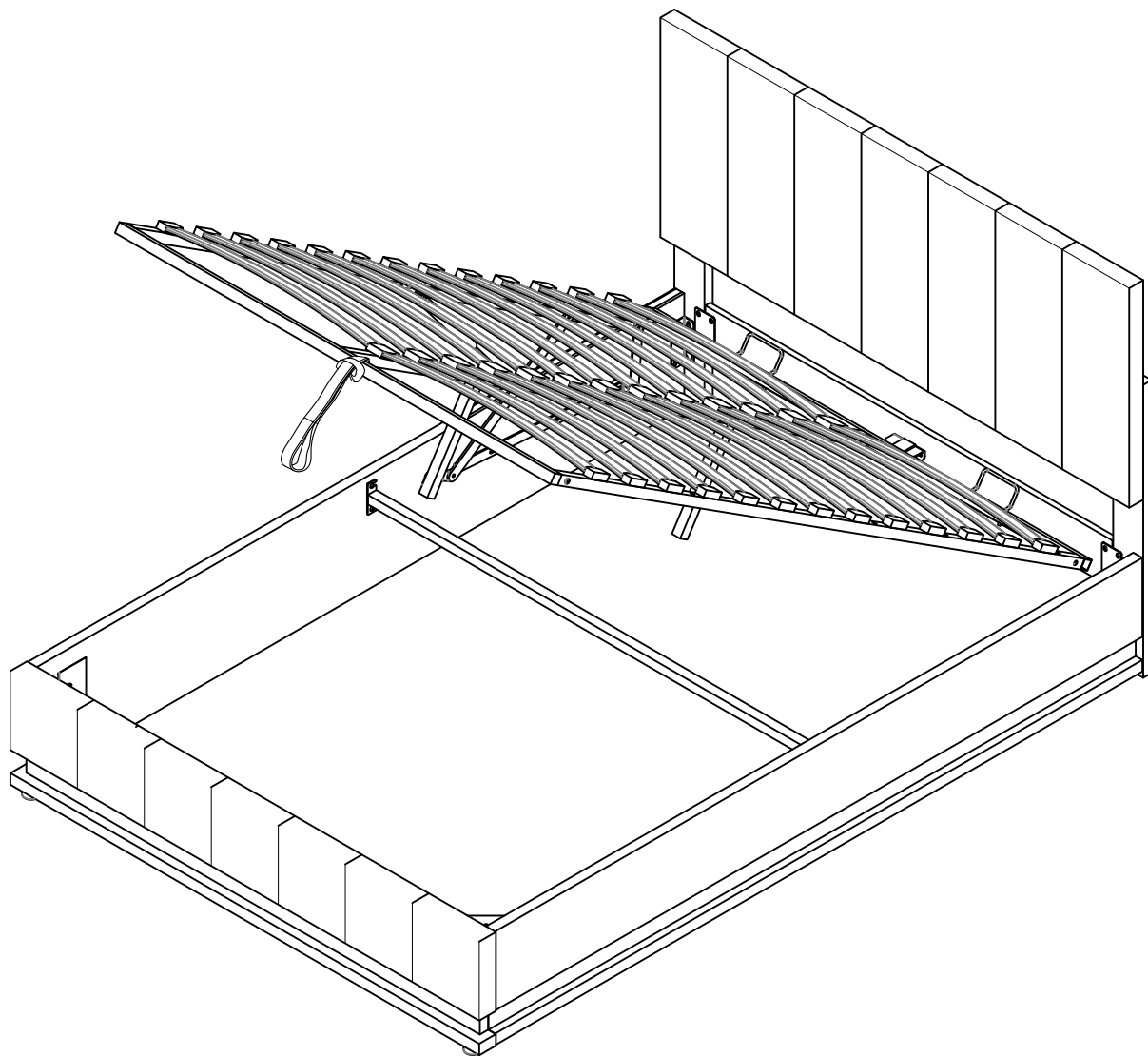



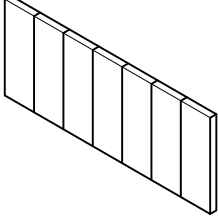
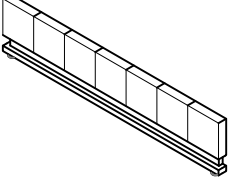
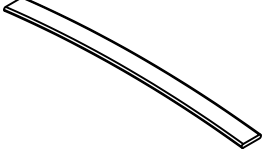
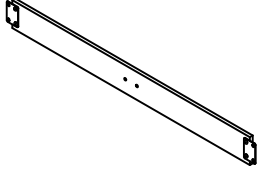

1. Please read the instructions fully before assembly. These instructions include important information which could ensure correct assembly. We have been working on providing high quality products for you. However, in the rare instance that your product is defective, missing parts or there are some issues, please don't hesitate to contact our customer service to submit parts requirements, assembly suggestion, or warranty claims, and we will give the best solution as soon as possible. If necessary, we need you to provide some more clear pictures of the issue.
2. Insert the screws in holes and tighten the screws, but not too tight, 70%~80% is ok, finally tighten all the screws. If some issues happened that some screws can not target to the hole or some parts are difficult to install, please adjust the tightness of the screws.
3. 2 people are recommended to finish



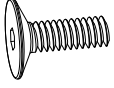
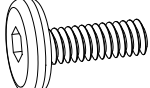
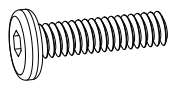
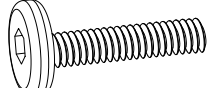
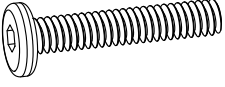

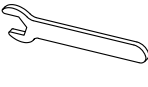

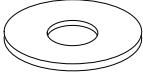

Part List WF304431AAA/WF304433AAA

<p>1</p>  <p>Headboard × 1</p>	<p>2</p>  <p>Footboard × 1</p>	<p>12</p>  <p>Slats × 26</p>	<p>18</p>  <p>Head board leg Connecting plate × 1</p>
<p>20L</p>  <p>Head board leg (LH) × 1</p>	<p>20R</p>  <p>Head board leg (RH) × 1</p>		

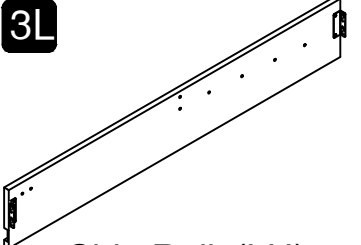
Hardware List WF304432AAA/WF304434AAA

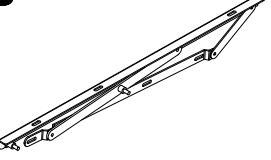
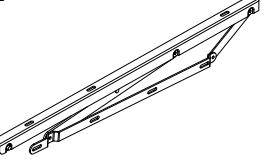
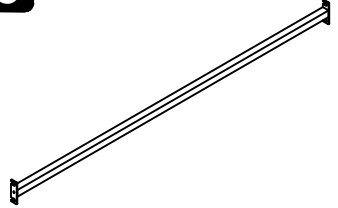
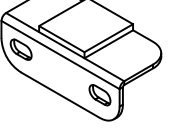
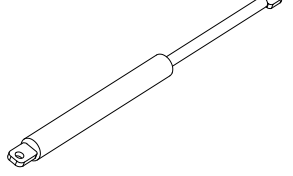
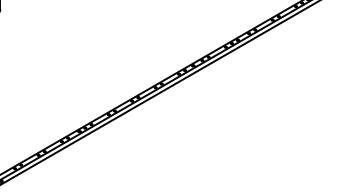
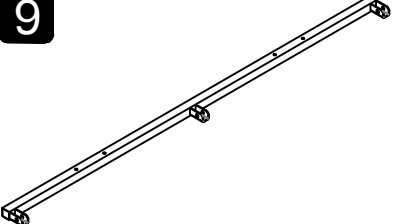
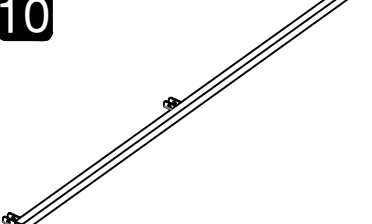
<p>A</p>  <p>Bolts(M8x18mm) × 4</p>	<p>B</p>  <p>Bolts(M8x20mm) × 24</p>	<p>C</p>  <p>Bolts(M8x30mm) × 8</p>	<p>D</p>  <p>Bolts(M8x40mm) × 12</p>
<p>E</p>  <p>Bolts(M8x50mm) × 4</p>	<p>F</p>  <p>Bolts(M6x35mm) × 2</p>	<p>G</p>  <p>Spanner × 1</p>	<p>H</p>  <p>Non-slip nuts (M8) × 16</p>
<p>J</p>  <p>Flat Washer × 12</p>	<p>K</p>  <p>Allen Key × 1</p>	<p>L</p>  <p>Plastic washer × 8</p>	

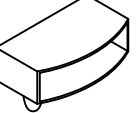
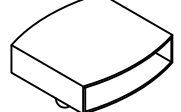
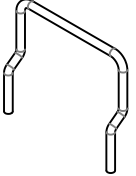
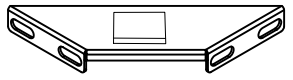
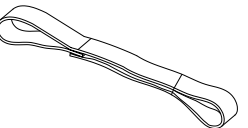
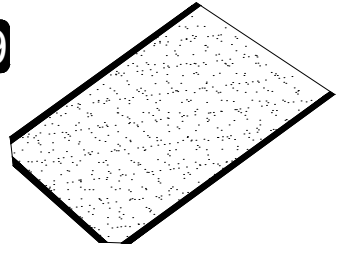
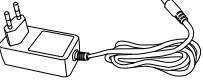
Part List WF304432AAA/WF304434AAA

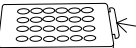
<p>3L</p>  <p>Side Rails(LH) × 1</p>	<p>3R</p>  <p>Side Rails(RH) × 1</p>	<p>4L</p>  <p>Lift Mechanism (LH) × 1</p>	<p>4R</p>  <p>Lift Mechanism (RH) × 1</p>
<p>5</p>  <p>Reinforced Pipe × 1</p>	<p>6</p>  <p>Angle Iron × 2</p>	<p>7</p>  <p>Gas Strut × 2</p>	<p>8</p>  <p>Side Rails for Metal Slat Frame × 3</p>
<p>9</p>  <p>Cross Rail for Metal Slat Frame - Headend × 1</p>	<p>10</p>  <p>Cross Rail for Metal Slat Frame - Footend × 1</p>	<p>11</p>  <p>Centre Support Leg × 2</p>	<p>13</p>  <p>Plastic Slat Caps × 26</p>
<p>14</p>  <p>Centre Slat Caps × 13</p>	<p>15</p>  <p>Mattress Stopper × 2</p>	<p>16</p>  <p>Metal Corner Bracket × 2</p>	<p>17</p>  <p>Rope × 1</p>
<p>19</p>  <p>Bottom cloth × 1</p>	<p>M</p>  <p>LED Power Transformer × 1</p>	<p>N</p>  <p>Controller × 1</p>	<p>O</p>  <p>Remote Control × 1</p> <p>Unplug the battery separator of the remote control before use</p>

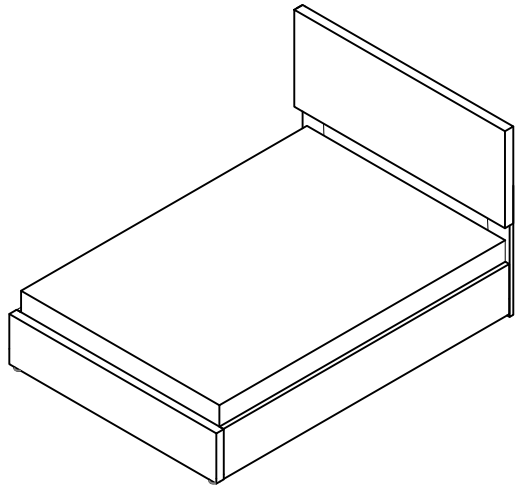

This product is not suitable for mattress recessed type.

(Dieses Produkt ist nicht für die eingebaute Platzierung von Matratzen geeignet.)

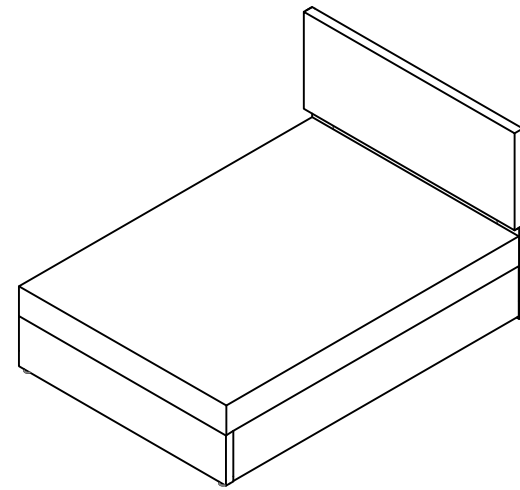

This product is suitable for placing mattresses on the top.

(Dieses Produkt eignet sich zum Platzieren von Matratzen auf der Oberseite.)

IMPORTANT NOTICE

OTTOMAN OPERATING INSTRUCTIONS

Once your bed frame is completely assembled, the slat unit will not operate correctly unless a mattress is placed on the slat frame. Position the mattress on the slat frame whilst it is in the closed position.

PLEASE NOTE - It takes a lot of force to make the initial movement of the ottoman. This is a design feature of the product so that it does not fall shut - the nearer to being closed the ottoman is, the easier it is to move. When the ottoman is almost shut, it will close completely under its own weight.

When lowering the slat unit for the first time, take care to make sure it does not rub unevenly on the inside face of the side rails. If it does, the bed has been assembled slightly out of square. This can be rectified by moving the foot end of the bed slightly to the left or right whilst leaving the head end stationary.

PISTONS

The pistons used in the construction of this product are extremely strong and cannot be operated by hand when taken off the ottoman. All pistons are tested for correct pressure and operation before being attached to the slat unit.

Initially it might appear that the pistons are very stiff when opening and closing the ottoman.

THIS IS PERFECTLY NORMAL

When fully assembled and the mattress is in position, please raise and lower the ottoman 4/5 times to ensure the gas piston are fully lubricated.

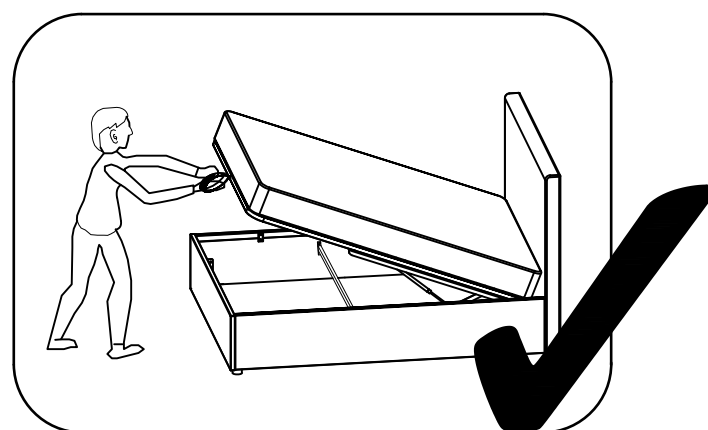
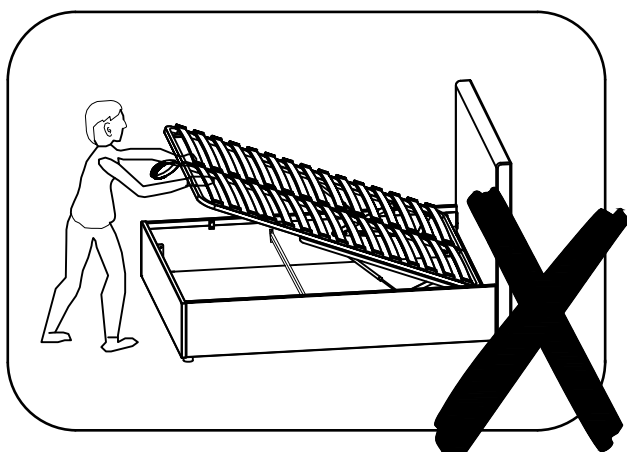

Attention: Do not tighten the screws before completing the entire installation. If you have any difficulty with the installation process, please feel free to contact us.

Step 1:

(E)  × 4

(J)  × 4

(K)  × 1

Fix the Headboard legs (20L) / (20R) to the headboard (1) with Bolts (E) and Flat Washer (J) by using Allen key (K), you can choose the holes a and b or b and c.

(Verwenden Sie den Inbusschlüssel (K) und verwenden Sie Schrauben (E) und flache Unterlegscheiben (J), um die Bein des Kopfbretts (20L)/(20R) am Kopfteil (1) zu befestigen. Sie können Loch a und Loch b oder Loch b und Loch c auswählen.)

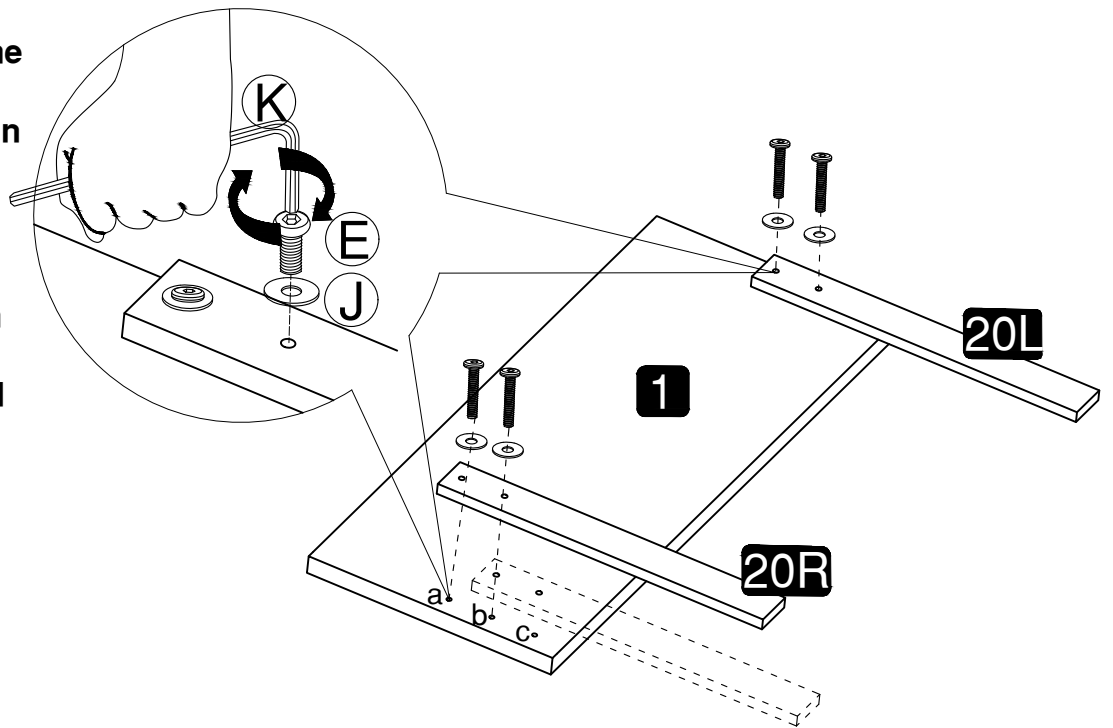

Step 2:

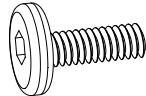
(B)  × 8

(K)  × 1

Fix the leg connecting plate (18) to the Head board leg (20L)/(20R) with Allen key (K) Bolts (B).

(Fixieren Sie die Beinverbindungsplatte (18) am Kopfplattenbein (20L)/(20R) mit Inbusschlüssel (K) Schrauben (B).)

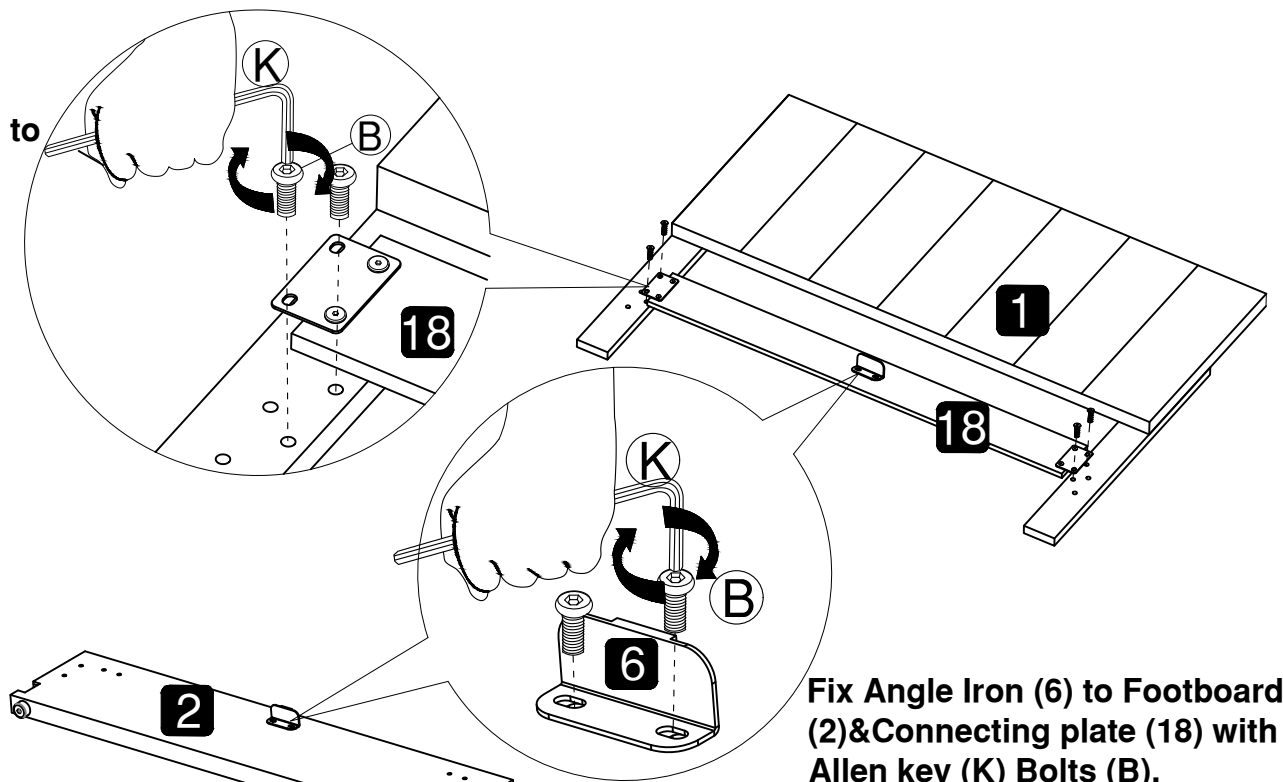

Fix Angle Iron (6) to Footboard (2) & Connecting plate (18) with Allen key (K) Bolts (B).

(Winkelisen (6) auf Pedal (2) und Anschlussplatte (18) mit Inbusschlüssel (K) Schrauben (B) befestigen.)

Ensure that the cushion angle iron is installed with the ledge facing upwards.

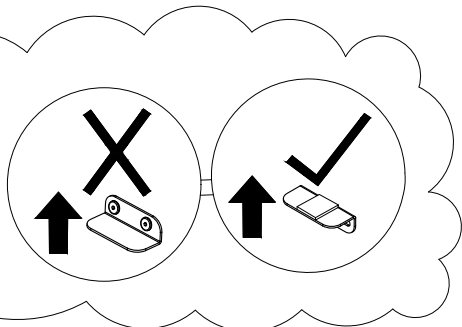

Step 3:

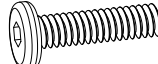
(C)  × 8

(L)  × 8

(K)  × 1

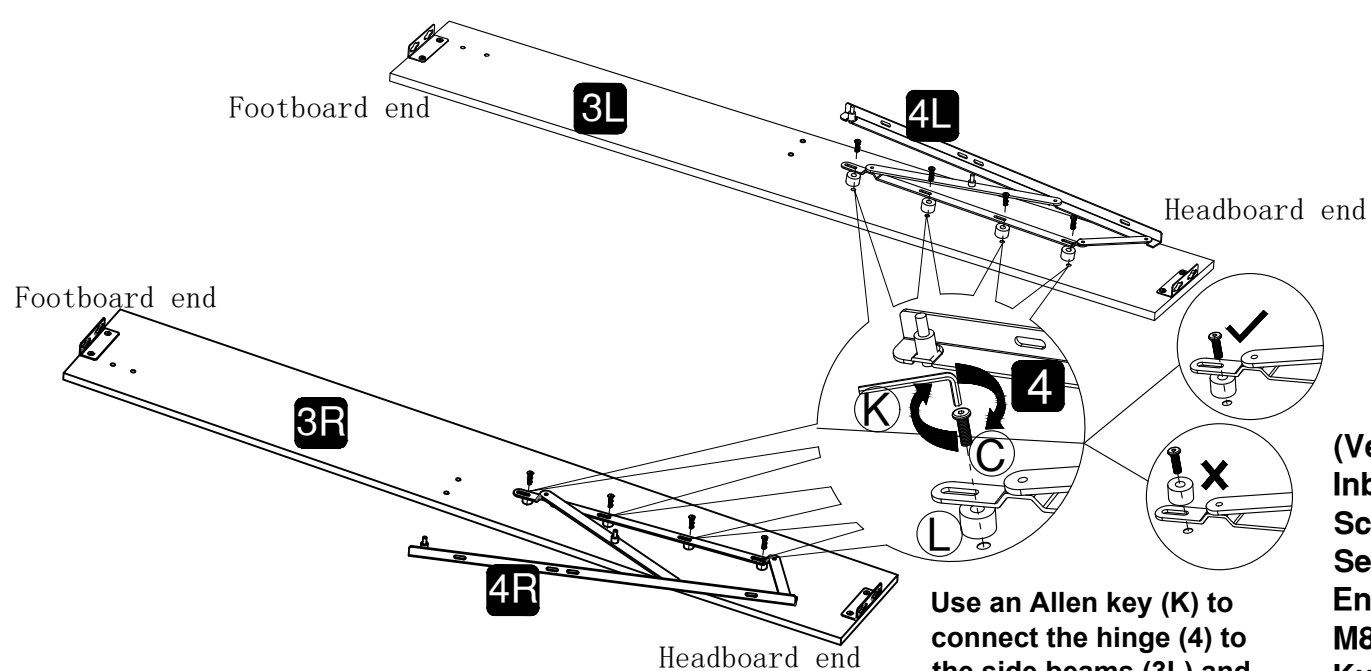

Use an Allen key (K) to connect the hinge (4) to the side beams (3L) and (3R) at the headboard end with M8 bolts (C) and plastic washers (L).

(Verwenden Sie einen Inbusschlüssel (K), um das Scharnier (4) mit den Seitenträgern (3L) und (3R) am Ende des Kopfteils mit M8-Schrauben (C) und Kunststoffscheiben (L) zu verbinden.)

Step 4:

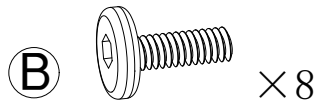

Fix the Side Rails (3L)&(3R) to the Head board leg (20L)/(20R) and Footboard (2) with a Allen key (K) and bolts (B).

(Befestigen Sie die Seitenschienen (3L) und (3R) mit einem Inbusschlüssel (K) und Schrauben (B) an den Stützen der Bein des Kopfbretts(20L)/(20R) und Pedalen (2).)

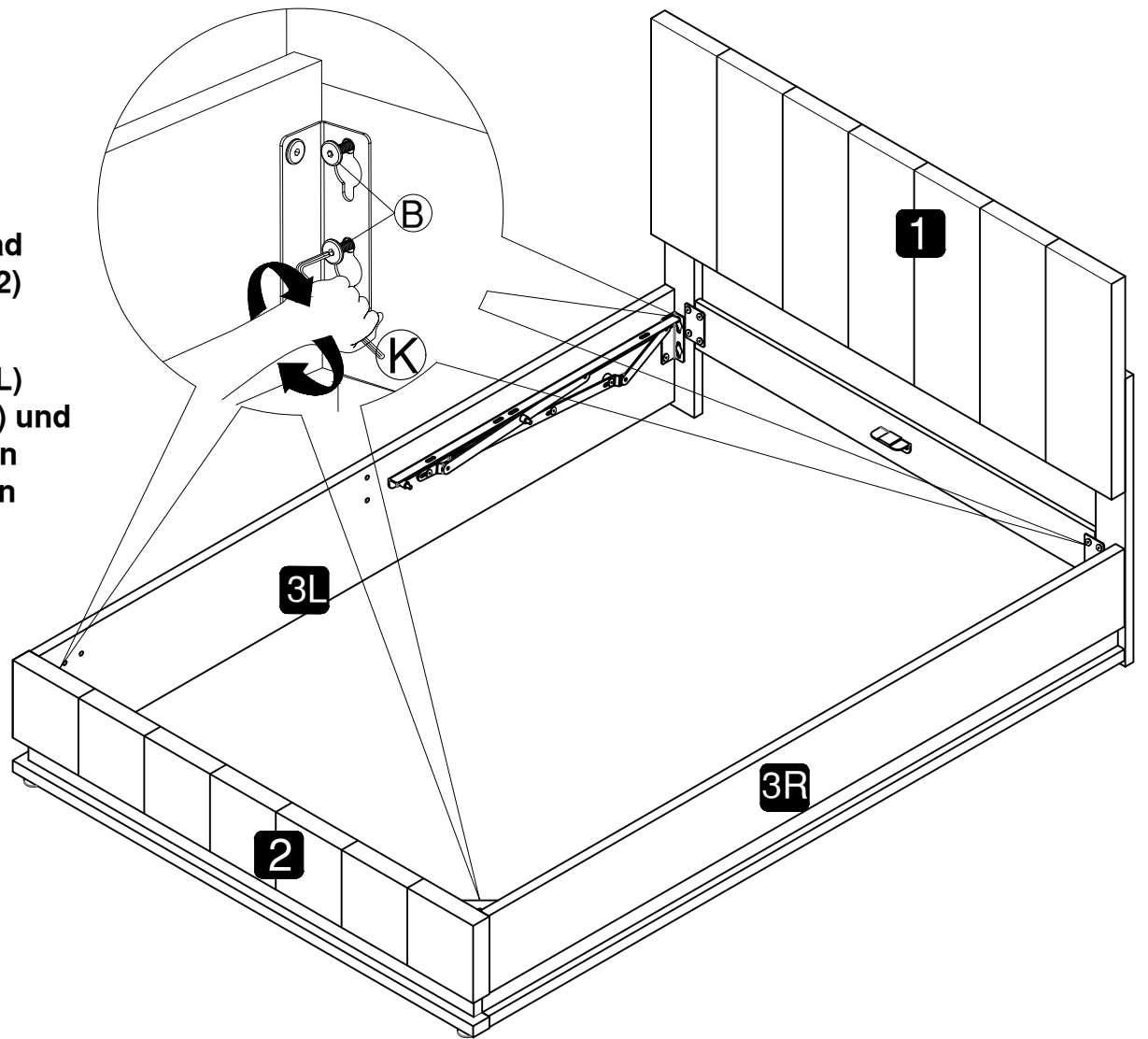

Step 5:

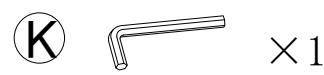
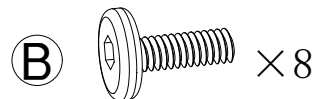
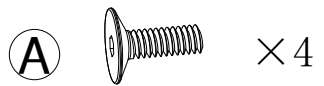

Use a Allen key (K) to connect the Reinforced Pipe (5) to the side member with bolts (A).

(Verwenden Sie einen Inbusschlüssel (K), um das Verstärkungsrohr (5) mit Schrauben (A) mit der Seitenplatte zu verbinden.)

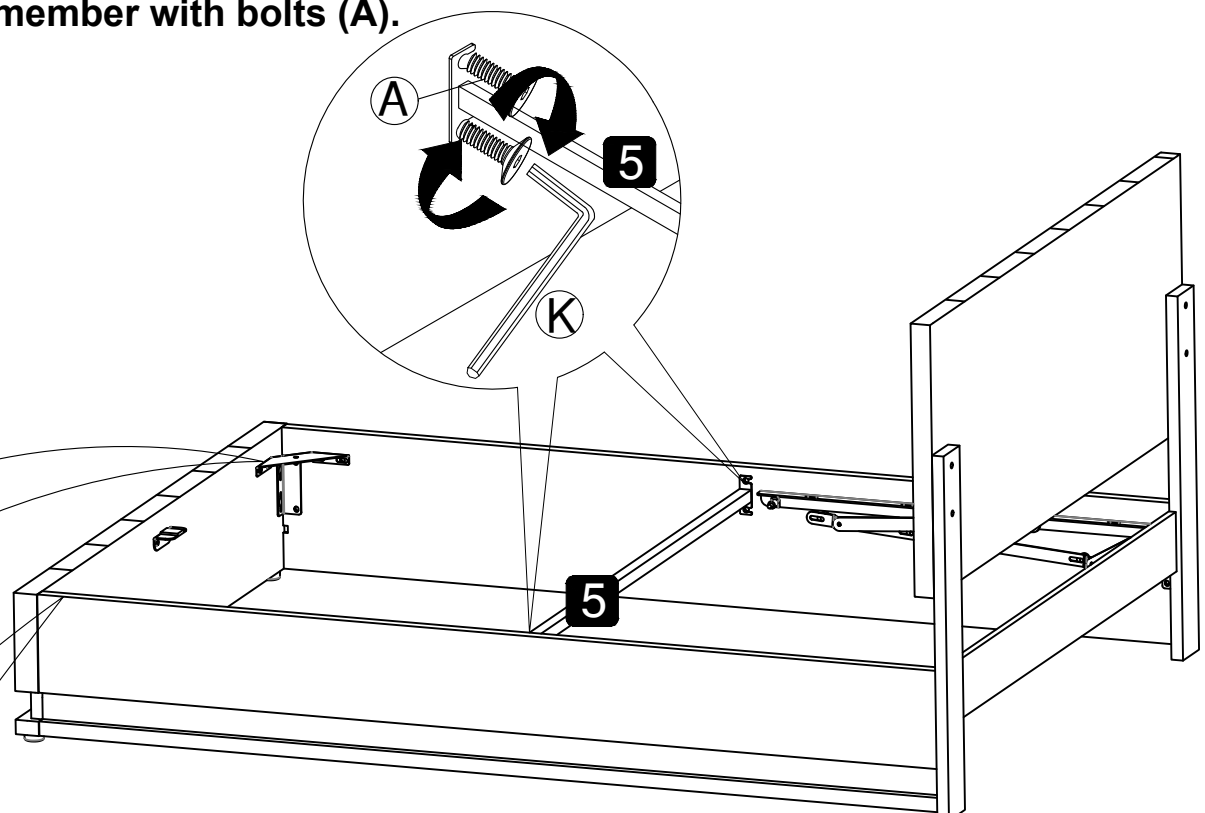

Use a Allen key (K) to fix the metal bracket (16) to the Side Rails and Footboard with bolts (B).

(Verwenden Sie einen Inbusschlüssel (K), um die Metallhalterung (16) am Seitenteil und Pedal mit Schrauben (B) zu befestigen.)

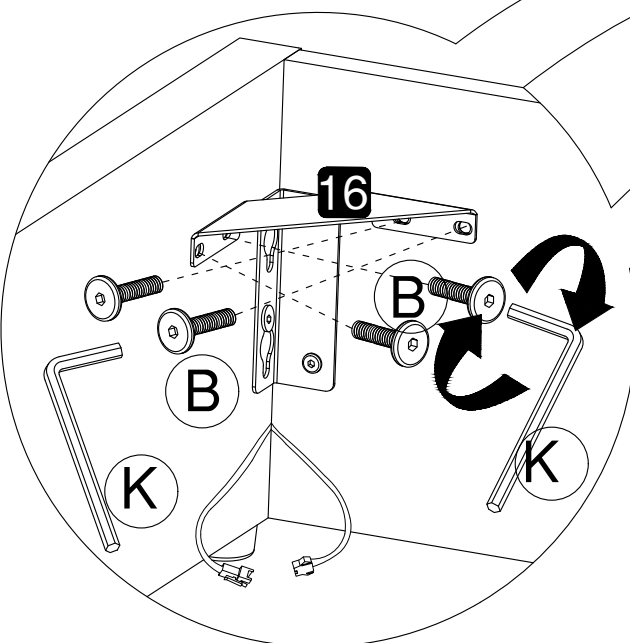

Step 6:

Stick the Bottom cloth (19) To
the bottom of bed



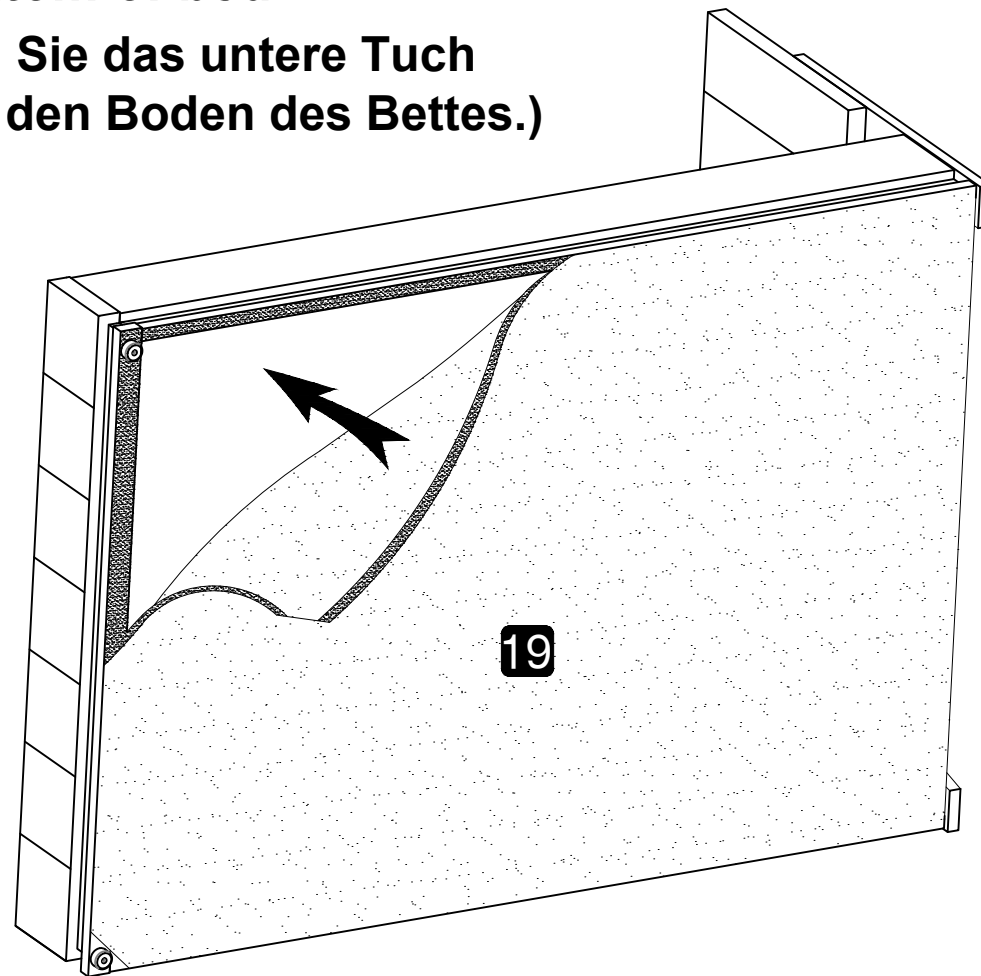

(Kleben Sie das untere Tuch
(19) Auf den Boden des Bettes.)



Step 7:

Bottom view, when connecting 8
and 9, make sure that the holes
in the dashed boxes are aligned.

(In der unteren Ansicht, wenn Sie 8
und 9 verbinden, stellen Sie sicher,
dass die Löcher in den gestrichelten
Kästchen ausgerichtet sind.)

- ⓓ  ×6
- ⓓ  ×6
- ⓐ  ×1
- Ⓚ  ×1
- ⓐ  ×6

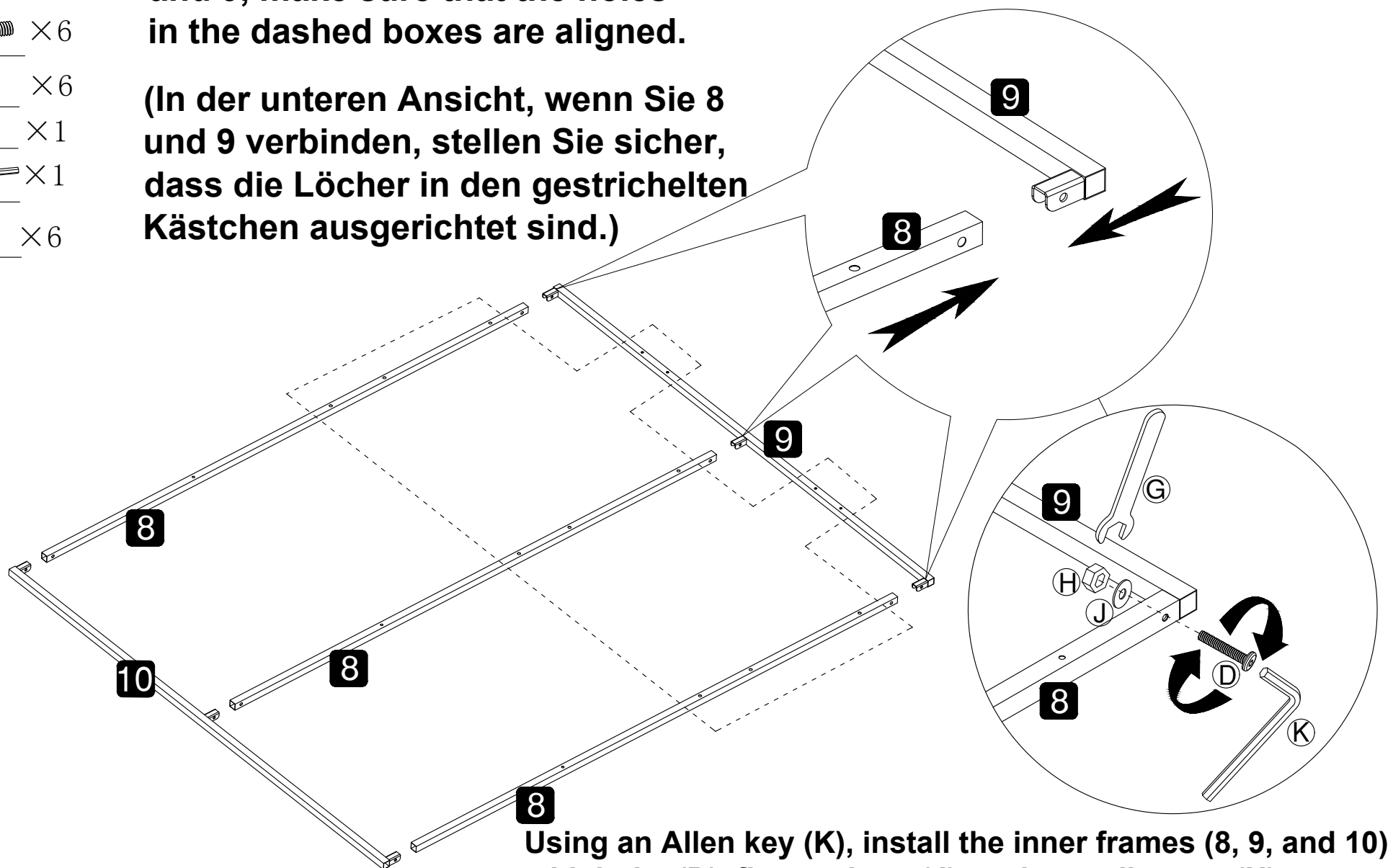





Using an Allen key (K), install the inner frames (8, 9, and 10)
with bolts (D), flat washers (J), and non slip nuts (H).

(Mit einem Inbusschlüssel (K) montieren Sie die
Innenrahmen (8, 9 und 10) mit Schrauben (D), Flache
Unterlegscheibe (J) und rutschfesten Muttern (H).)

Step 8:

Use an Allen key (K) to connect the center leg (11) to the center pipe (8) with M6 bolts (F) and flat washers (J).

(Benutze einen Inbusschlüssel (K), um das Mittelbein (11) mit dem Mittelrohr (8) mit M6-Schrauben (F) und Flachscheiben (J) zu verbinden.)

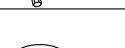
- D**  × 6
- F**  × 2
- H**  × 6
- G**  × 1
- K**  × 1
- J**  × 2

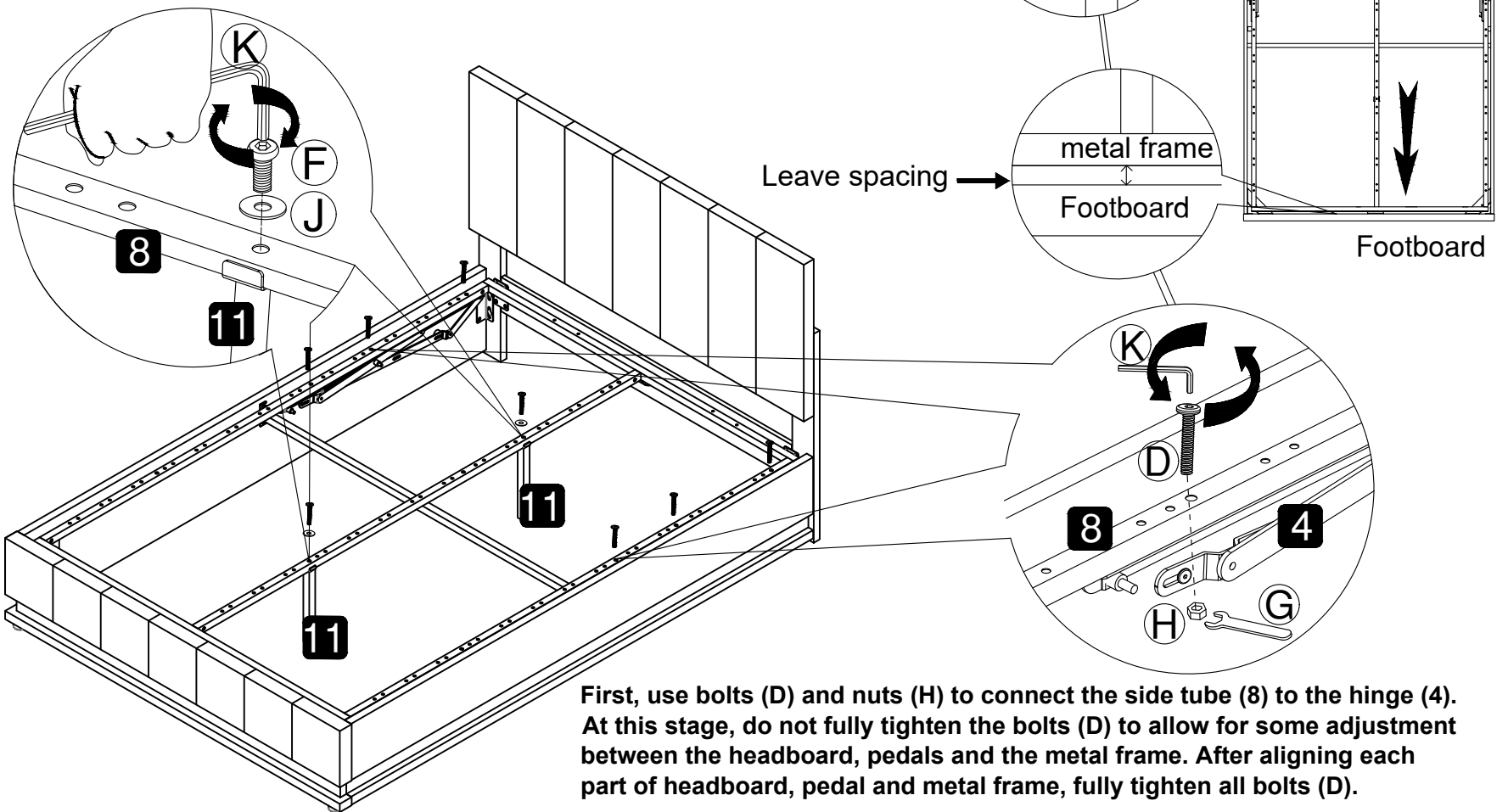

First, use bolts (D) and nuts (H) to connect the side tube (8) to the hinge (4). At this stage, do not fully tighten the bolts (D) to allow for some adjustment between the headboard, pedals and the metal frame. After aligning each part of headboard, pedal and metal frame, fully tighten all bolts (D).

(Verwenden Sie zuerst Schrauben (D) und Muttern (H), um das Seitenrohr (8) mit dem Scharnier (4) zu verbinden. Ziehen Sie in diesem Stadium die Schrauben (D) nicht vollständig fest, um eine gewisse Anpassung zwischen Kopfteil, Pedalen und Metallrahmen zu ermöglichen. Kopfteil, Pedal und Metallrahmen, nachdem Sie jedes Teil ausgerichtet haben, ziehen Sie alle Schrauben fest (D).)

Step 9:

Attach the plastic slat caps (13) to each slat (12) at the side Then press down the hole corresponding to the side pipe (8).

(Befestigen Sie die Kunststofflamellenabdeckung (13) an jeder Lamelle (12) an der Seite und drücken Sie das Loch entsprechend dem Seitenrohr (8).)

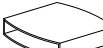
- 13**  × 26
- 14**  × 13

Insert the Mattress Stopper (15) into the hole corresponding to Cross Rail for Metal Slat Frame (9).

(Setzen Sie den Matratzenstopper (15) in das Loch ein, das der Querschienen für Metalllattenrahmen entspricht (9).)

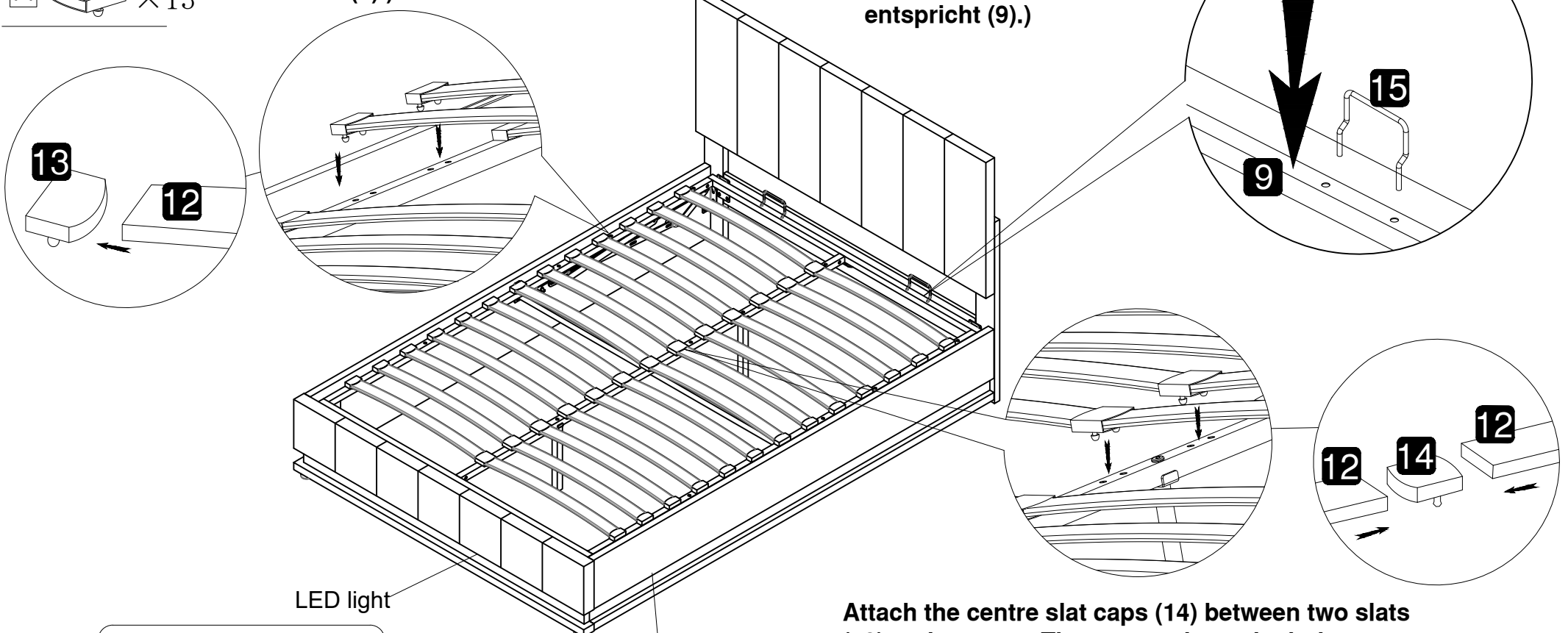

LED light

LED light

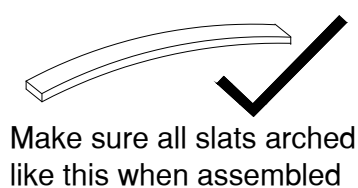

Make sure all slats arched like this when assembled

Attach the centre slat caps (14) between two slats (12) at the centre Then press down the hole corresponding to the side pipe (8).

(Verbinden Sie die mittlere Streifenabdeckung (14) zwischen den beiden Streifen (12) in der Mitte und drücken Sie dann das Loch, das dem Seitenrohr entspricht (8).)

Step 10:

H  ×4

G  ×1

17  ×1

Attach the gas struts (7) to the hinge (4) with M8 nuts (H) as shown.

(Verbinden Sie die Gasfeder (7) mit dem Scharnier (4) mit M8 Muttern (H) wie abgebildet.)

As shown in the figure, tie the rope (17) to the Cross Rail for Metal Slat Frame - Footend On the internal frame.

(Wie in der Abbildung gezeigt, binden Sie das Seil (17) an die Querstange des Metalllattenrahmens auf dem inneren Rahmen.)

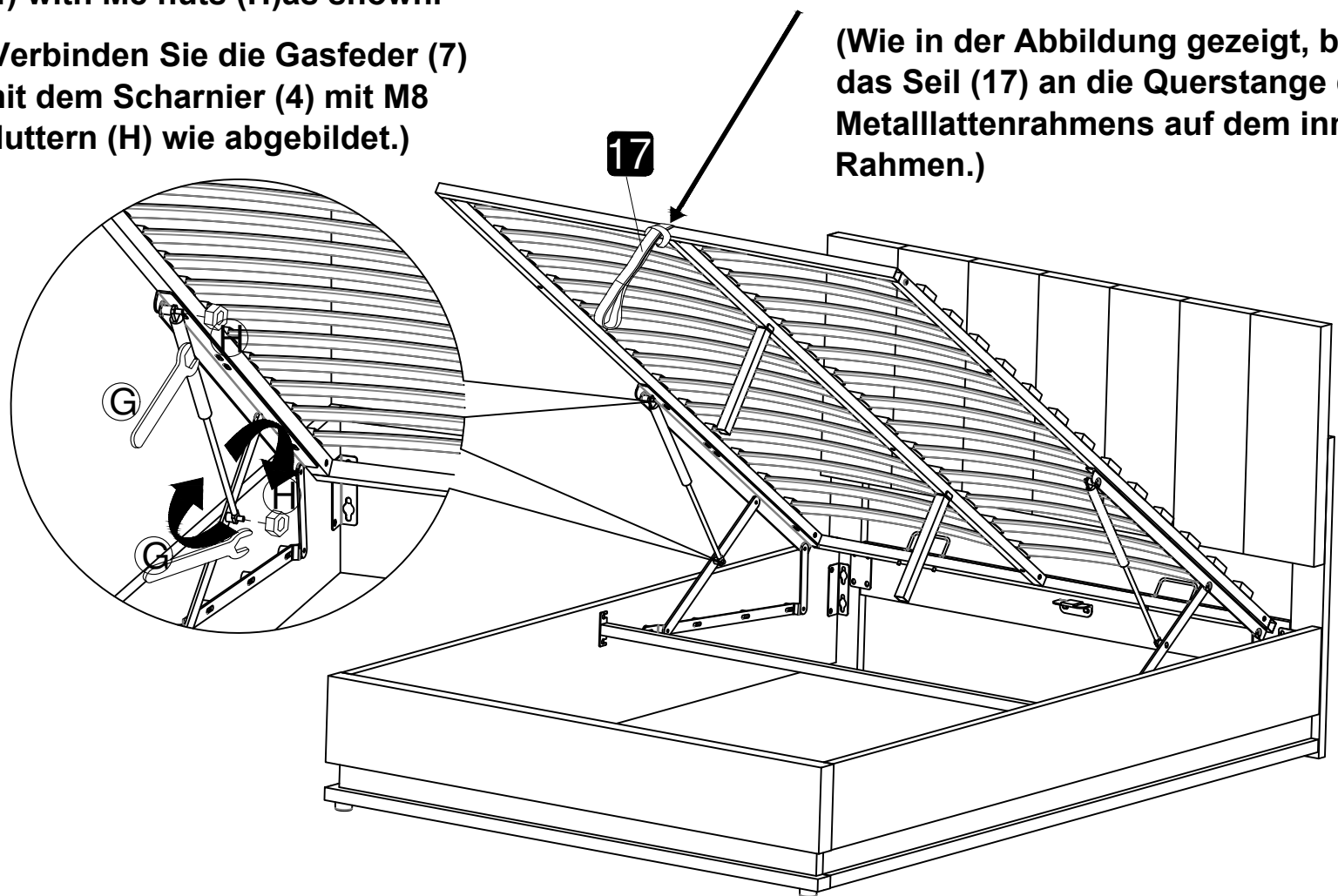

Step 11:

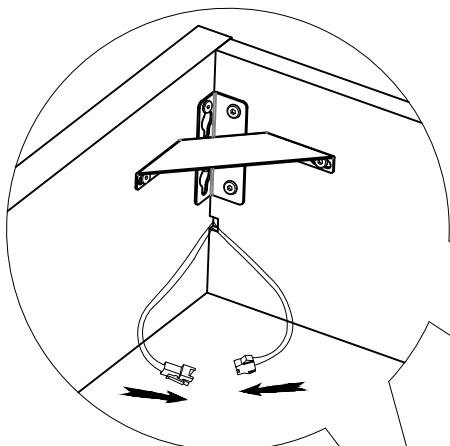

The LED light wires on both sides of the inside of footboard (2) are connected with the light wires of side rail left (3L) side rail right (3R)

(Die LED-Lichtdrähte auf beiden Seiten der Innenseite des Trittbretts (2) sind mit den Lichtdrähten der Seitenschiene links (3L) rechts (3R) verbunden.)

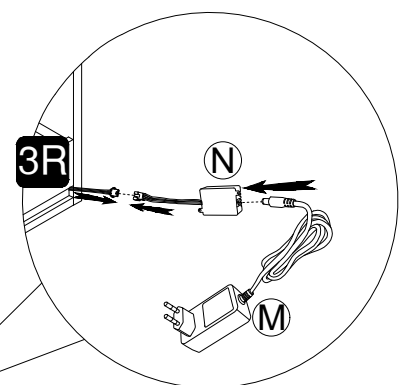
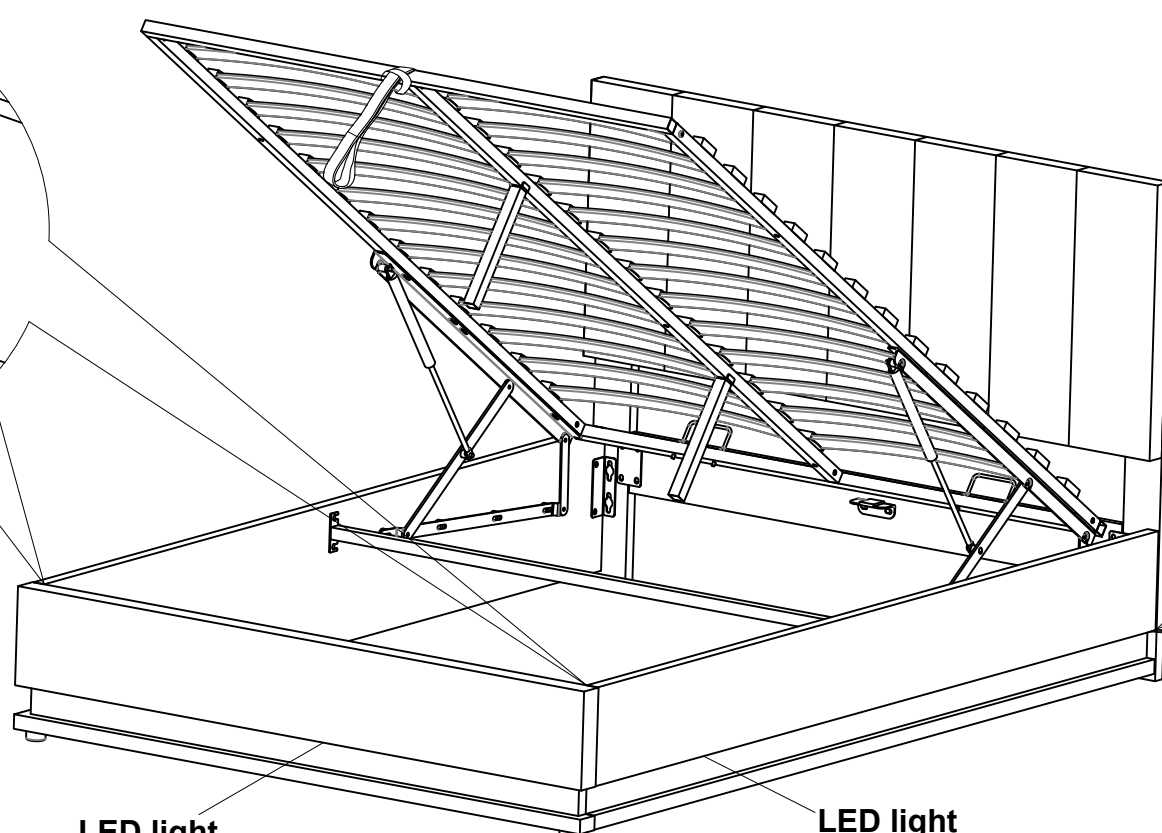

Connect the LED controller (N) to the Side Rail Right (3R). Then plug in the power adaptor (M) to the controller as shown

(Verbinden Sie den LED-Controller (N) mit der Seitenschiene rechts (3R). Schließen Sie dann das Netzteil (M) wie abgebildet an den Controller an.)

LED light

If you can't let the lights work successfully, please check the following:

1. Please check the direction of the connect, try it in the opposite direction, according to the following picture.
2. Please check the remote control, it need you to tear down the plastic septum before use it.
3. If one of the colors is not bright, please check whether the four wires in the plug are skewed, and move the main line to make the four wires flush.

(LED-Licht)

(Wenn Sie die Lampe nicht erfolgreich funktionieren lassen, überprüfen Sie bitte Folgendes:

1. Bitte überprüfen Sie die Verbindungsrichtung und versuchen Sie in der entgegengesetzten Richtung gemäß der Abbildung unten.
2. Bitte überprüfen Sie die Fernbedienung und entfernen Sie die Kunststoffmembran vor Gebrauch.
3. Wenn eine der Farben nicht hell ist, überprüfen Sie bitte, ob die vier Drähte im Stecker schief sind, und bewegen Sie die Hauptleitung, um die vier Drähte bündig zu machen.)

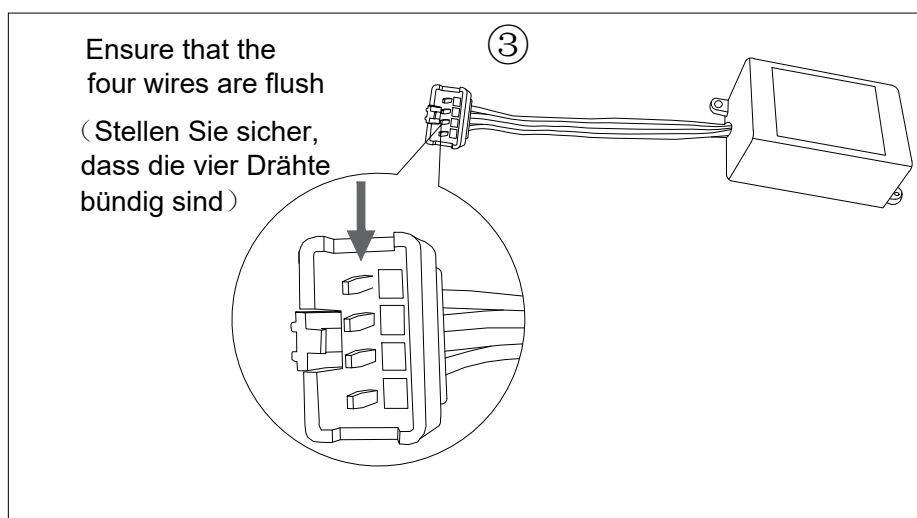
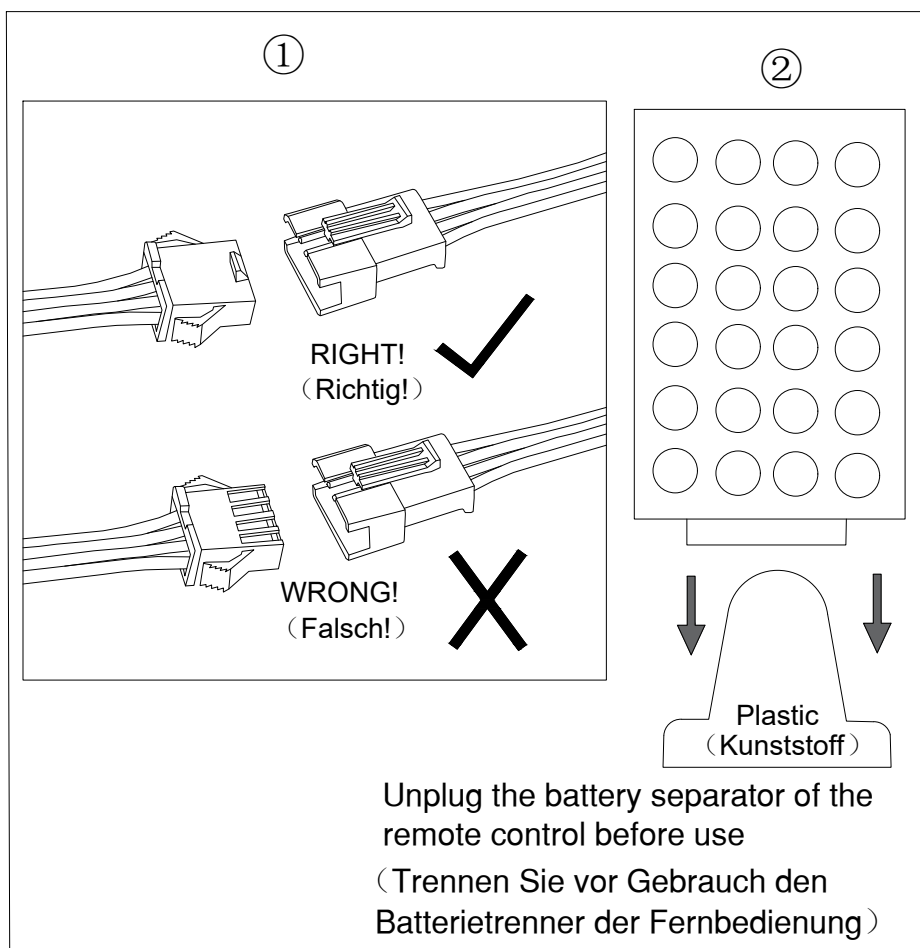

1. Please check the direction of the arrow
2. Please pull the plastic block out of the remote control
3. Please check whether the four wires of the plug are neat

- (1. Bitte überprüfen Sie die Richtung des Pfeils
2. Ziehen Sie bitte den Kunststoffblock von der Fernbedienung
3. Bitte überprüfen Sie, ob die vier Drähte des Steckers bündig sind)

Operation Instructions of Controller (Betriebsanleitung des Reglers)

I. Specifications: (Spezifikationen)

Working temperature: -20-60 °C
(Arbeitstemperatur: -20-60 °C)

Supply voltage: DC12V
(Versorgungsspannung: DC12V)

Product size: L62xW35xH23mm
(Produktgröße: L62xW35xH23mm)

Package size: L95xW68xH45mm
(Packungsgröße: L95xW68xH45mm)

Net weight: 42g
(Nettogewicht: 42g)

Gross weight: 57g
(Bruttogewicht: 57g)

Output: Three CMOS drain- open output
(Ausgabe: Drei CMOS Drain- Open Ausgang)

Connecting Mode: Common anode
(Verbindungsmodus: Gemeinsame Anode)

Max load current: 2 A each color
(Maximaler Ladestrom: 2 A pro Farbe)

II. Control Method:

Adopt RF remoter to control the led controller, which has 24 buttons, the function of each button as the table below:

(Kontrollmethode:

Nehmen Sie RF-Fernbedienung an, um den geführten Controller zu steuern, der 24-Tasten hat, die Funktion jeder Taste wie die Tabelle unten:)

Brightness +(Speed up) (Helligkeit +(Beschleunigung))	Brightness - (Speed down) (Helligkeit - (Geschwindigkeit runter))	Off (Aus)	On (Ein)
Static red (Statisches Rot)	Static green (Statisch grün)	Static blue (Statisch blau)	Static white (Statisch weiß)
Static orange (Statisch orange)	Static pea green (Statisches Erbsengrün)	Static dark blue (Statisch dunkelblau)	7 color jumpy change (7 Farbwechsel)
Static dark yellow (Statisch dunkelgelb)	Static cyan (Statisches Cyan)	Static brown (Statisch braun)	All fade out&fade in (All fade out&fade in)
Static yellow (Statisch gelb)	Static light blue (Statisch hellblau)	Static pink (Statisch rosa)	7 color fade change (7 Farbwechsel)
Static straw yellow (Statisches Strohgelb)	Static sky blue (Statisches Himmelblau)	Static purple (Statisches Lila)	3 base color jumpy (3 Grundfarbe nervös)

III. Panel specification and connecting drawing as follows: (Plattenspezifikation und Anschlusszeichnung wie folgt)

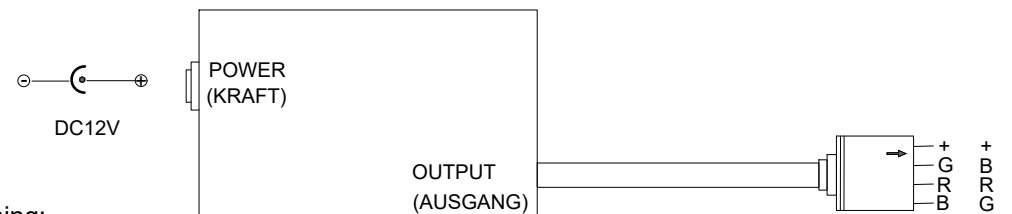

IV. Warning:

1. Supply voltage of this product is DC12V never connect to DC24V or AC220V.
2. Never connect two wires directly in case of short circuit.
3. Lead wire should be connected correctly according to colors that connecting diagram offers.
4. Warranty of this product is one year, in this period we guarantee replacement or repairing with no charge, but exclude the artificial situation of damaged or overload working.

(Warnung:

1. Supply Spannung dieses Produkts ist DC12V niemals mit DC24V oder AC220V verbinden.
2. Nie verbinden Sie zwei Drähte direkt im Falle eines Kurzschlusses.
3. Lead Draht sollte entsprechend den Farben richtig angeschlossen werden, die Verbindungsdiagramm anbietet.
4. Warranty dieses Produkts beträgt ein Jahr, in diesem Zeitraum garantieren wir Ersatz oder Reparatur ohne Gebühr, schließen aber die künstliche Situation der beschädigten oder überlasteten Arbeit aus.)

! WARNING

THIS PRODUCT CONTAINS A BUTTON BATTERY

If swallowed, a lithium button battery can cause severe or fatal injuries within 2 hours.

Keep batteries out of reach of children.

If you think batteries may have been swallowed or placed inside any part of the body, seek immediate medical attention.

! WARNUNG

Dieses Produkt enthält eine Knopfatterie

Beim Verschlucken kann eine Lithium-Knopfbatterie innerhalb von zwei Stunden schwere oder tödliche Verletzungen verursachen.

Bewahren Sie Batterien außerhalb der Reichweite von Kindern auf.

Wenn Sie glauben, dass Batterien verschluckt oder in einen Teil des Körpers gelegt wurden, suchen Sie sofort einen Arzt auf.