

1/11  
→ || ← 28mm

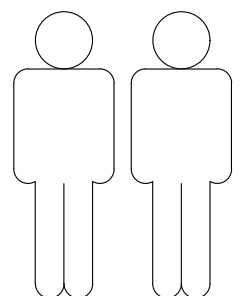

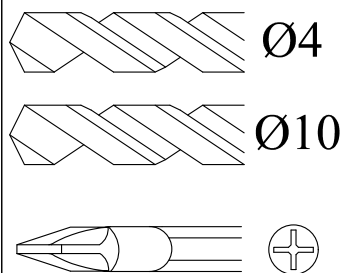

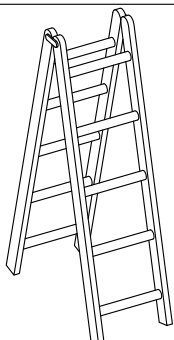

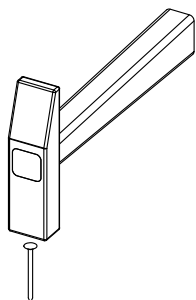
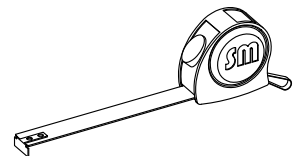
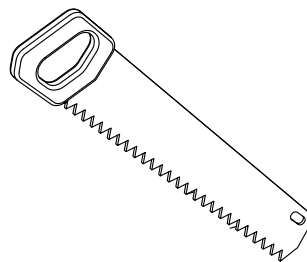
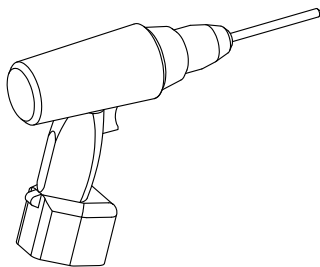
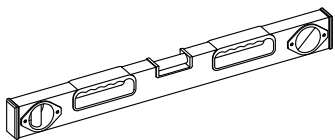

2,6 x 2,6

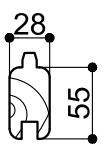
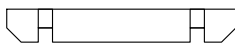
28028

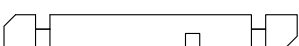
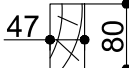
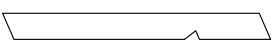
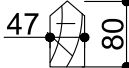
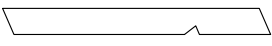
DE  
FR  
ENG

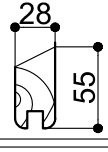
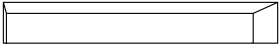

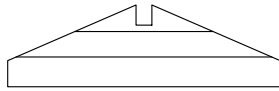
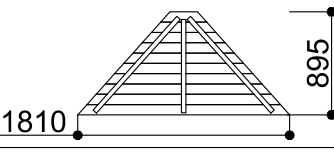
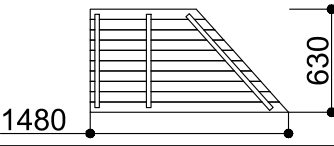
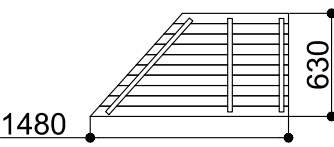
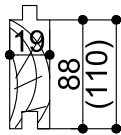
Dim.	Skizze, Sketch, Sketch	Pos.	Länge, Longueur, Length,mm	Quantity Quantität Quantité	Name, Nom, Name	Ref.
		①	2365	1	Fundamentbalken Lambourdes Foundation beam	283057
		②	2305	5	Fundamentbalken Lambourdes Foundation beam	283058
		③	1555	2	Fundamentbalken Lambourdes Foundation beam	283048
		④	1221	1	Fundamentbalken Lambourdes Foundation beam	283050
		⑥	280	1	Front Brett Madrier avant Front board	280123
		⑦	1740	1	Seiten Brett Madrier latéral Side board	280115
		⑧	2600	1	Zurück Brett Madrier arrière Back board	280113
		⑱	280	1	Front Brett Madrier avant Front board	280126
		⑳	505	1	Seiten Brett Madrier latéral Side board	280119
		㉑	505	1	Seiten Brett Madrier latéral Side board	280120
		㉕	2600	1	Seiten Brett Madrier latéral Side board	280121
		⑨	280	17	Front Brett Madrier avant Front board	280125
		⑰	280	17	Front Brett Madrier avant Front board	280124
		⑩	1740	5	Seiten Brett Madrier latéral Side board	280109
		⑪	2600	37	Zurück Brett Madrier arrière Back board	280047
		⑫	505	25	Seiten Brett Madrier latéral Side board	280111
		⑬	1740	4	Seiten Brett Madrier latéral Side board	280116
		⑭	505	12	Seiten Brett Madrier latéral Side board	280118
		⑮	505	13	Seiten Brett Madrier latéral Side board	280110
		⑯	1740	1	Seiten Brett Madrier latéral Side board	280117
		⑲	1415	1	Front Brett Madrier avant Front board	280127
		㉓	2600	1	Seiten Brett Madrier latéral Side board	280112

		22	2600	1	Zurück Brett Madrier arrière Back board	280114
		24	1415	1	Front Brett Madrier avant Front board	280128
		26	2600	1	Seiten Brett Madrier latéral Side board	280122
		27	1530	4	Sparren Panne faitière Rafters	284057
		28	2105	4	Sparren Panne faitière Rafters	284056
		29		1	Verbindungen Composé Rafters join	286991
		30	1200	4	Top Brett Madrier haut Top board	281036
		31	1200	4	Top Brett Madrier haut Top board	281037
		32	1195	1	Wandpaneel Panneau de mur Wall panel	282023
		33	1810 x895	4	Dachplatte Panneau de toit Roof panel	284607
		35	1480 x630	4	Dachplatte Panneau de toit Roof panel	284613
		34	1480 x630	4	Dachplatte Panneau de toit Roof panel	284612
		38	2360	27 (22)	Boden Bretter Plancher bois Floor board	283502

		39	1540	1	Bodenleiste Plancher latte Baseboard	283233
		40	2380	2	Bodenleiste Plancher latte Baseboard	283226
		41	1540	1	Bodenleiste Plancher latte Baseboard	283233
		42	600	1	Bodenleiste Plancher latte Baseboard	283268
43						
		44	1550	4	Wind Brett Planche de rive Wind board	285019
		45	1550	4	Wind Brett Planche de rive Wind board	285018

	TR1	1973	1	Türrahmen links Cadre de porte gauche Door frame left	289223
	TR2	1973	1	Türrahmen rechts Cadre de porte droite Door frame right	289202
	TR3	945	1	Über Türrahmen Montant supérieur Door frame top	289203
	TR4	745	1	Türstufe Latte de finition bas Door frame bottom	289204
	T1	765x 1850	1	Tür Porte Doors	289012
	F	850x 1530	2	Fenster Fenêtre Window	289105

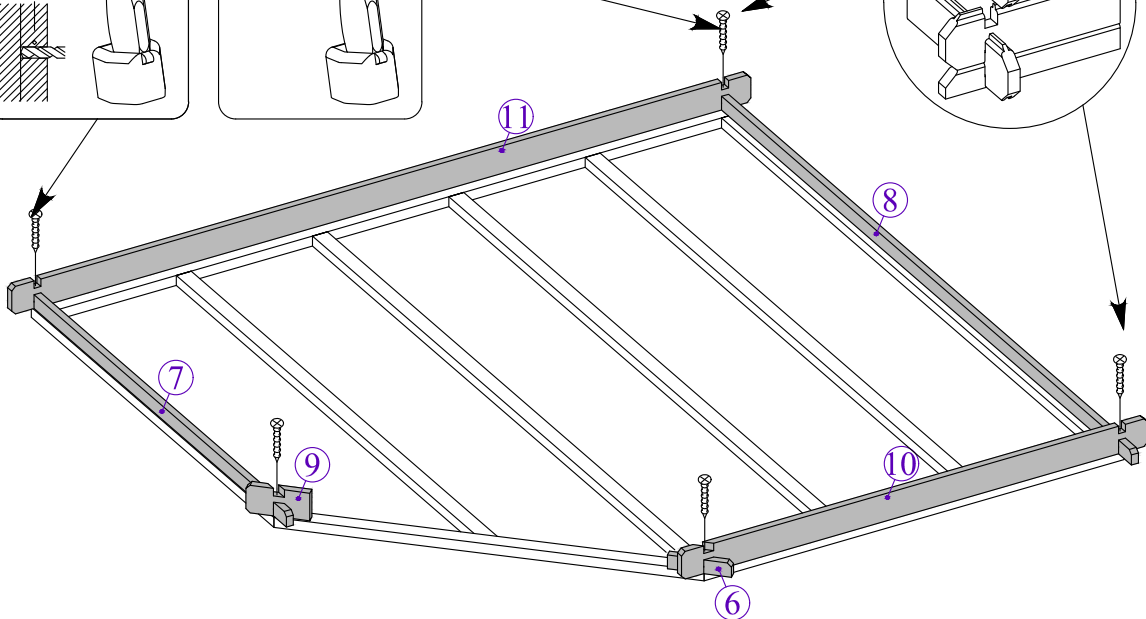
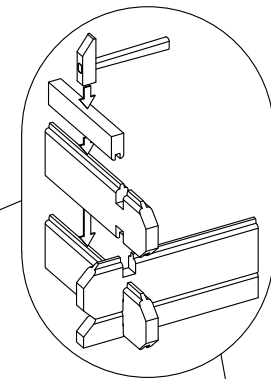
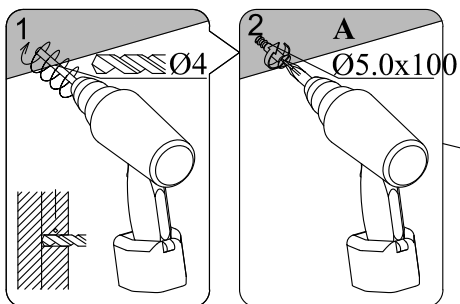
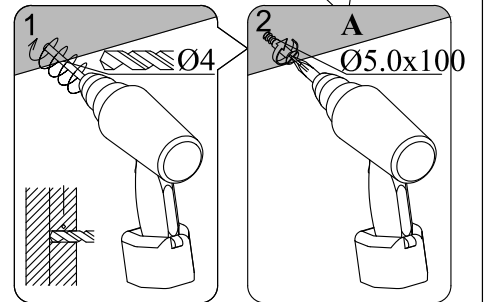
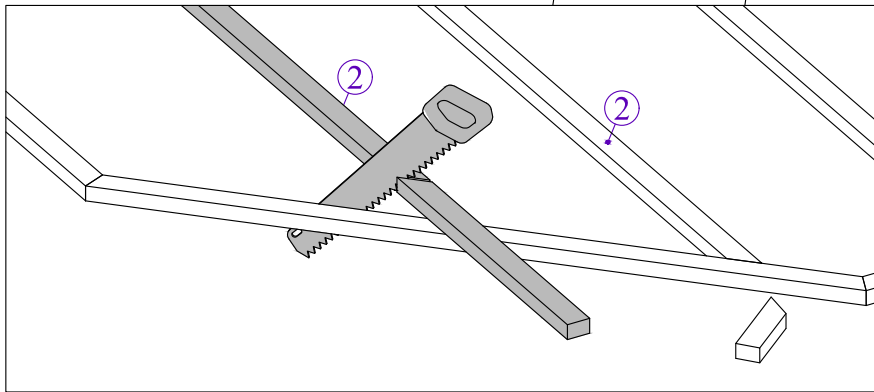
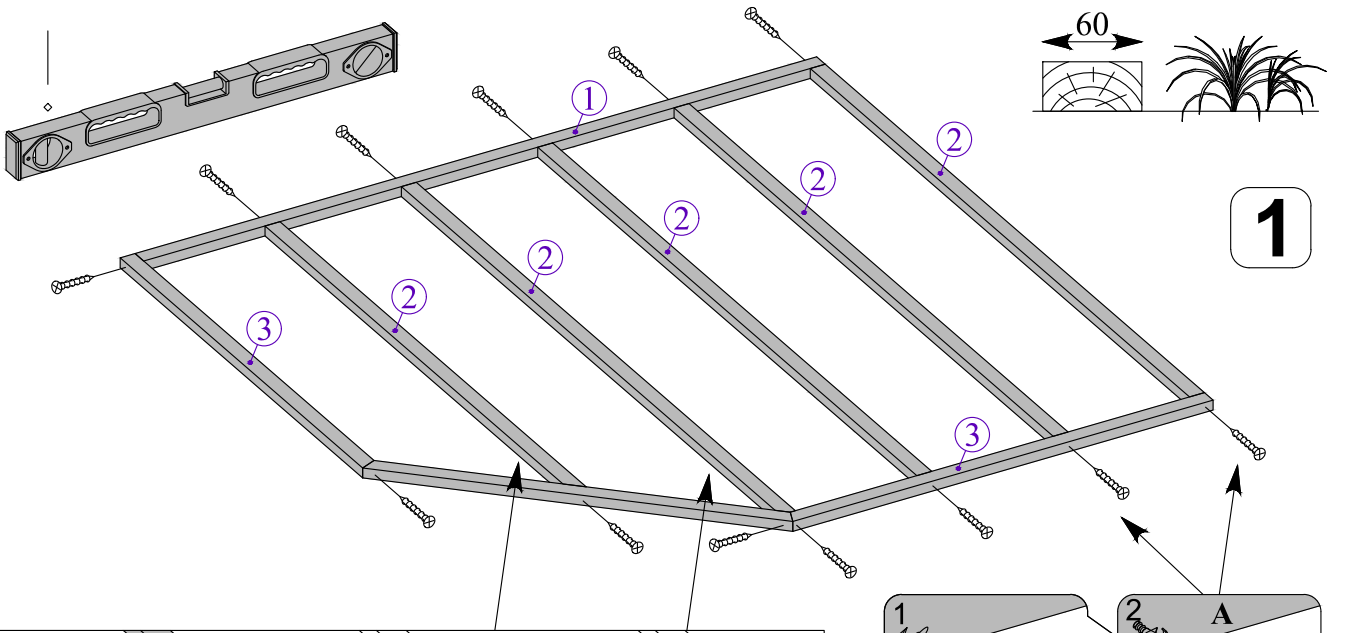

3

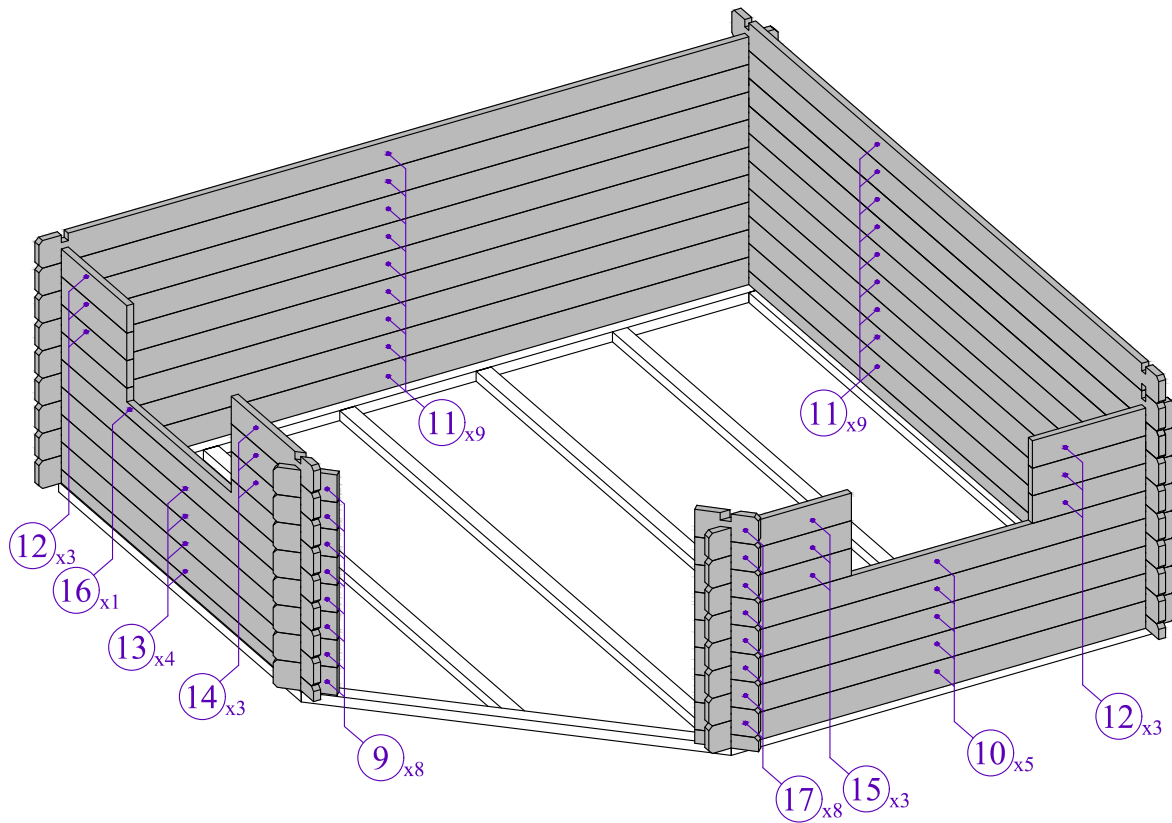

4

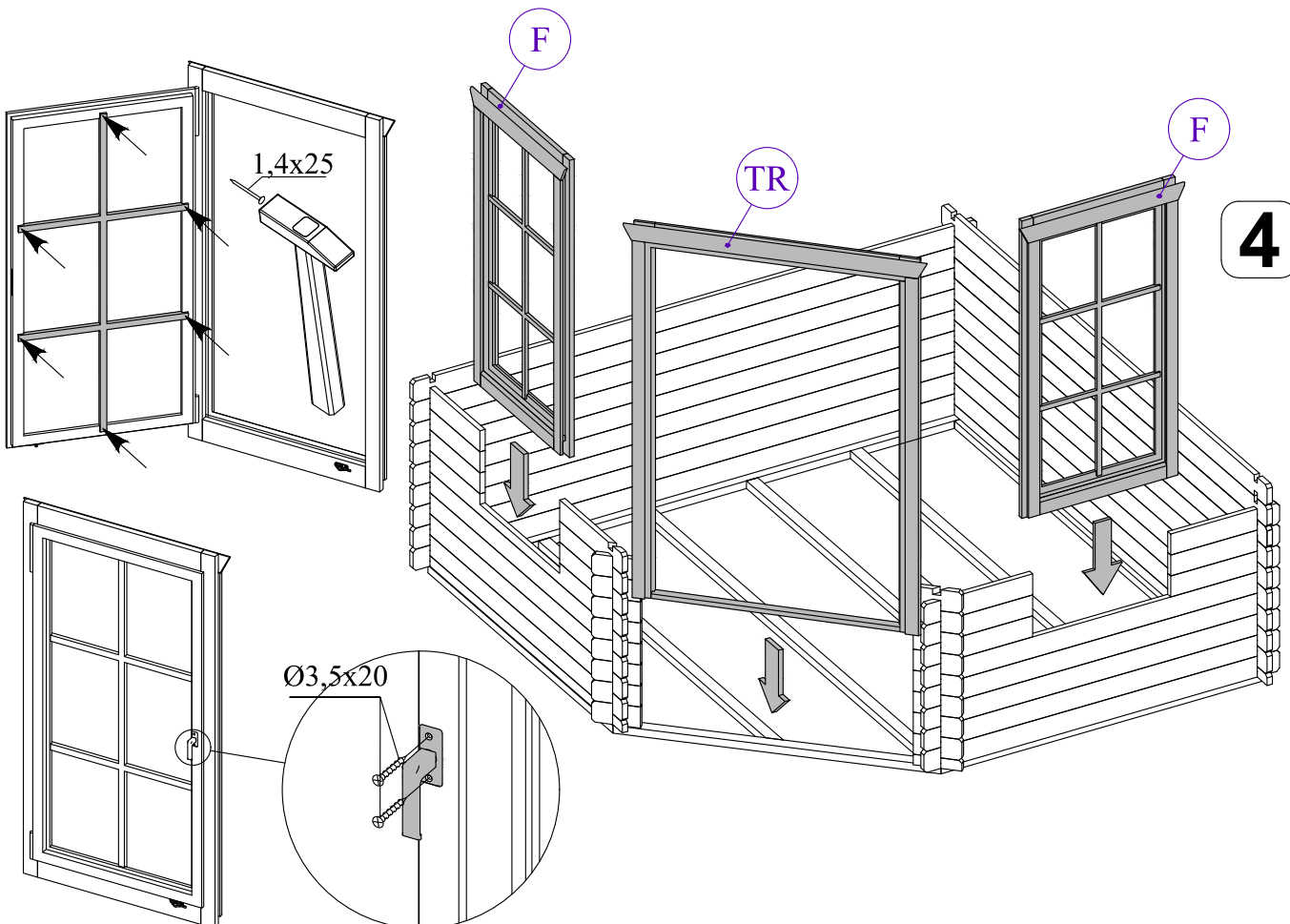

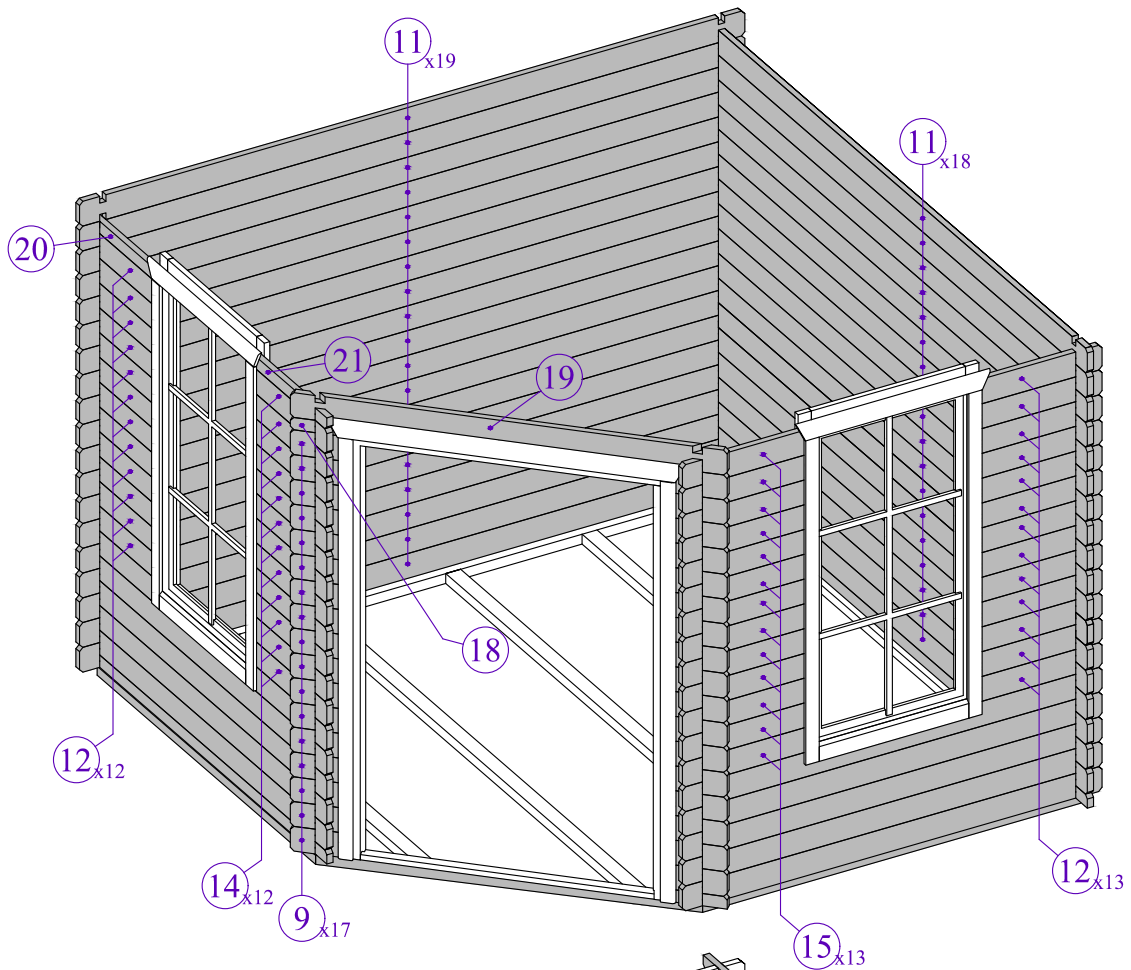

5

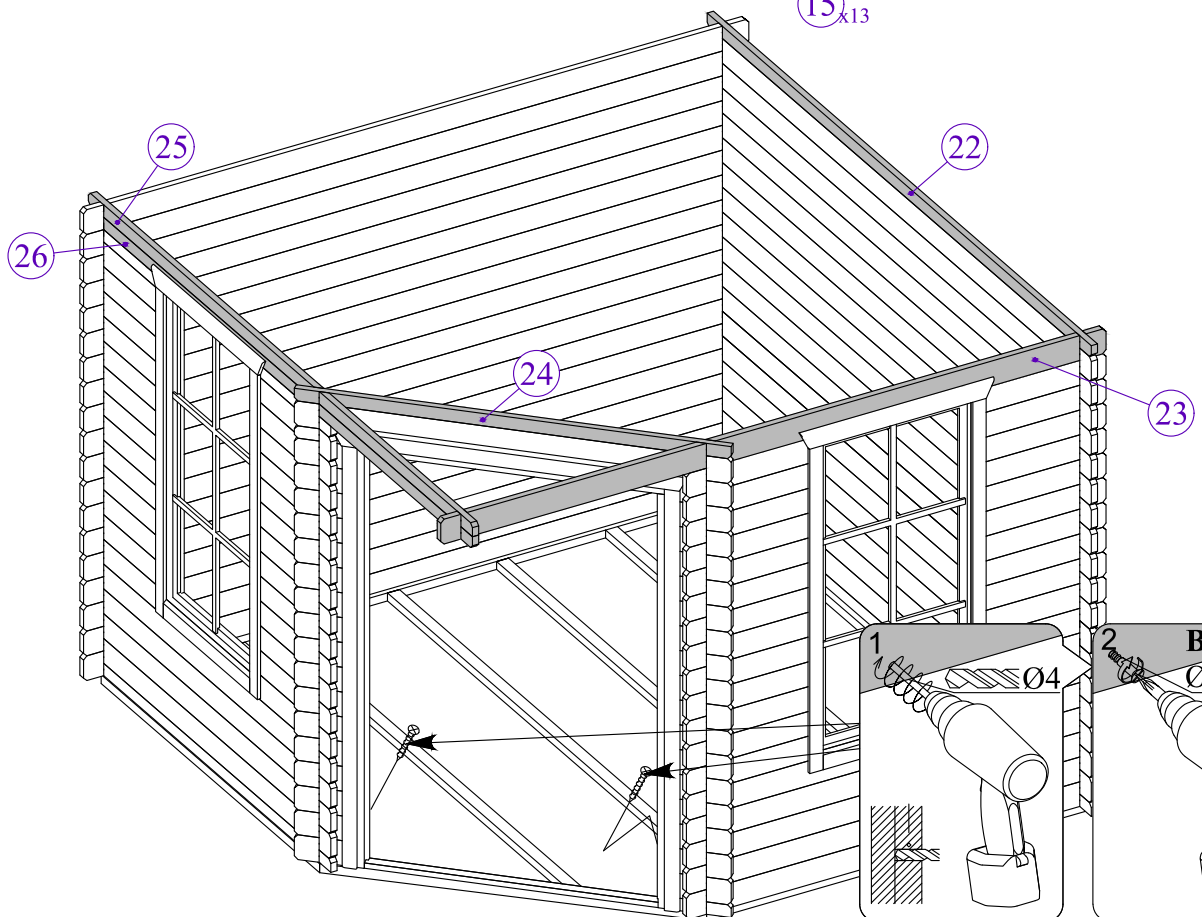

6

7

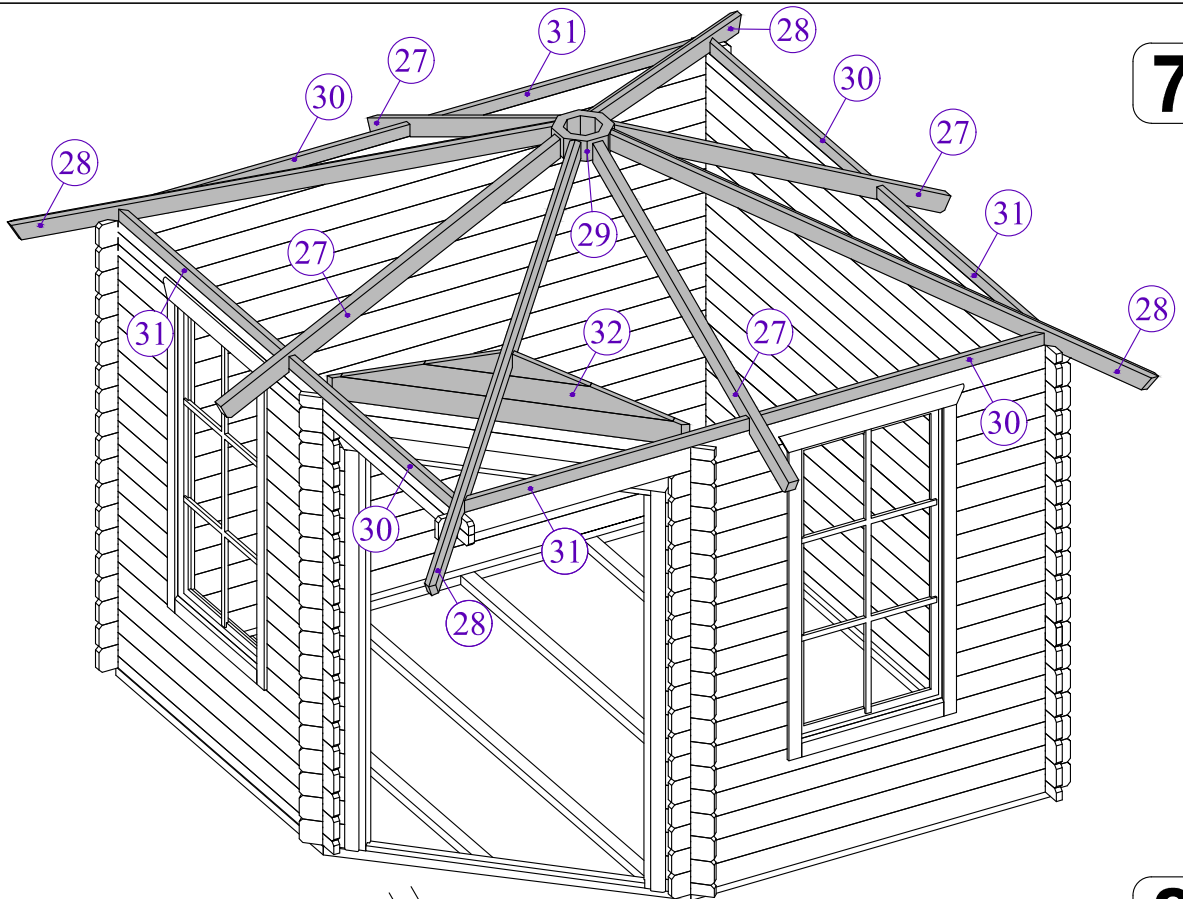

8

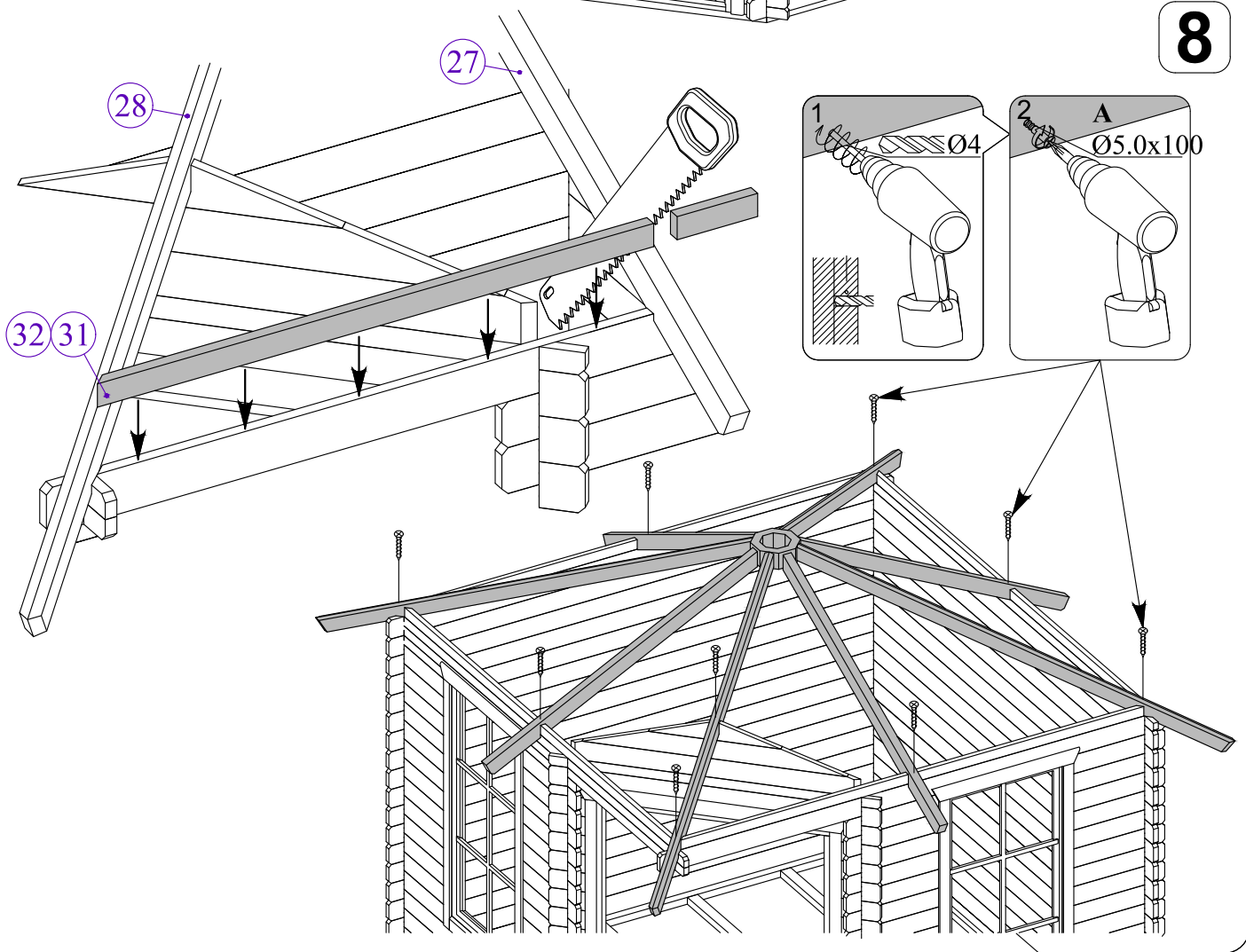



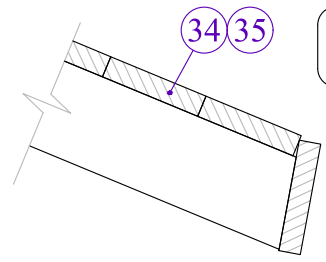
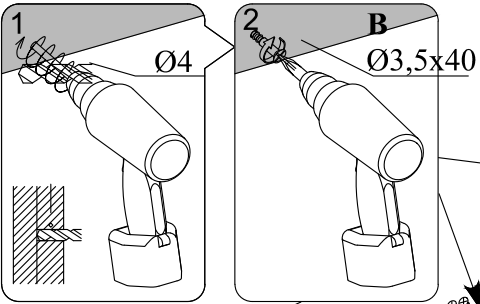

9

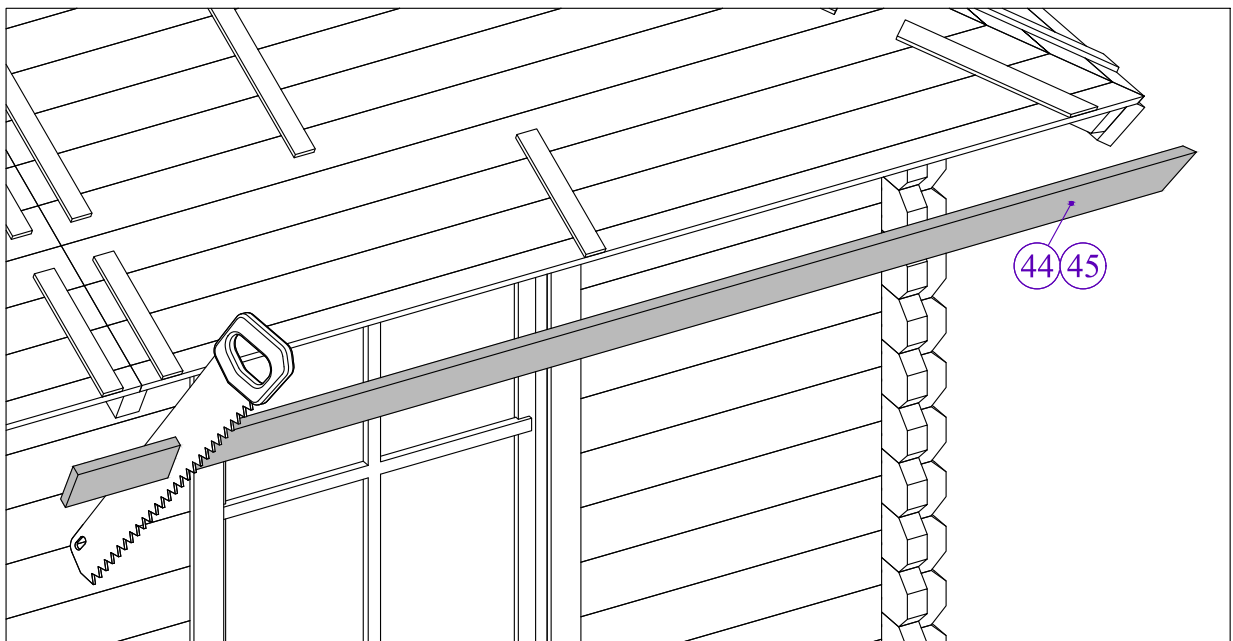
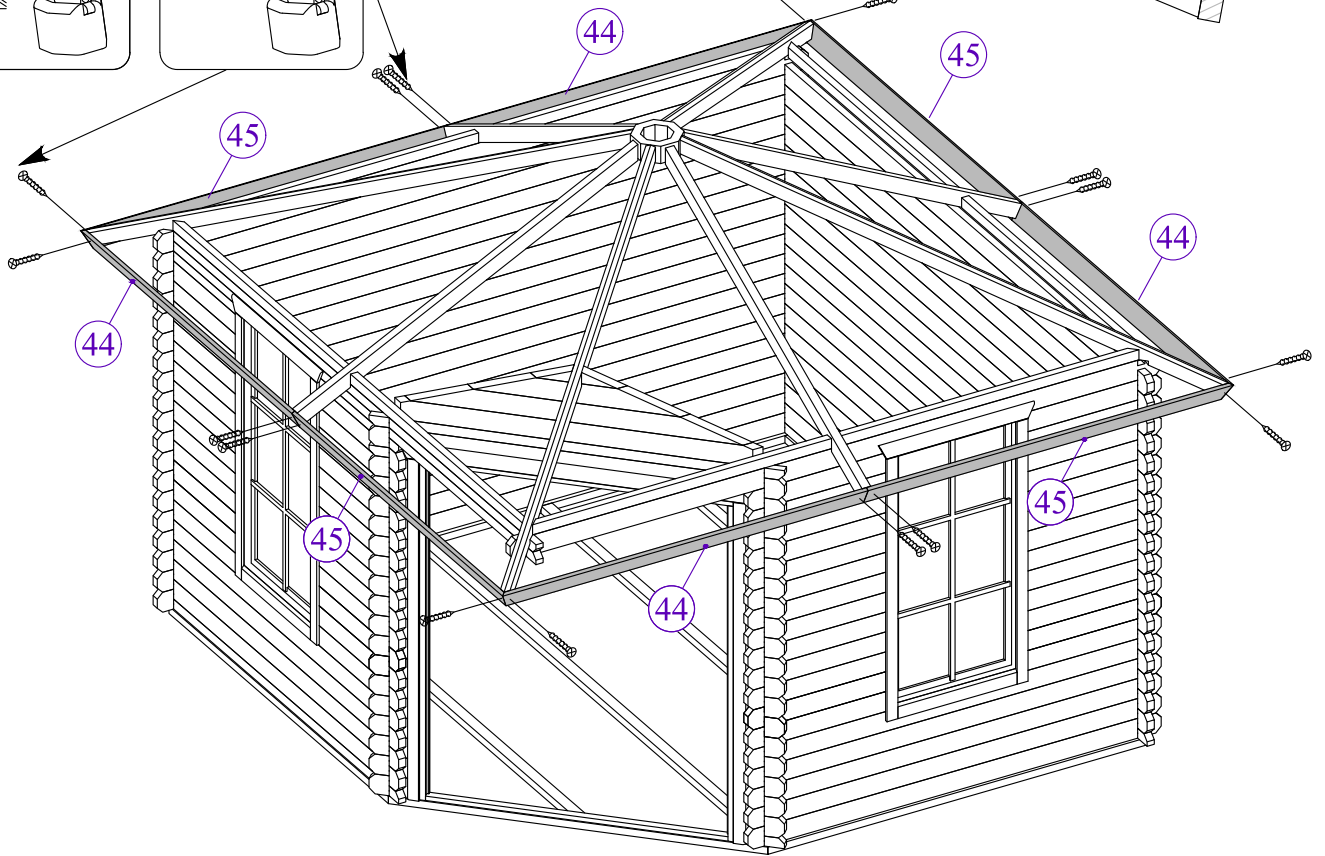

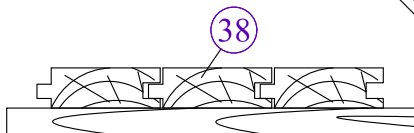
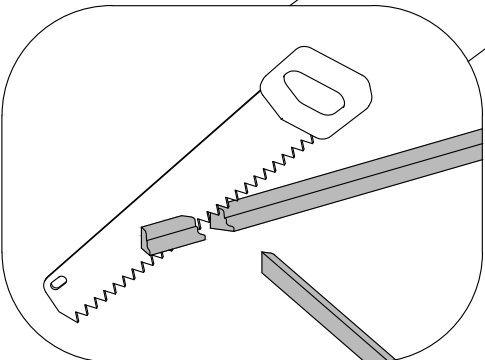
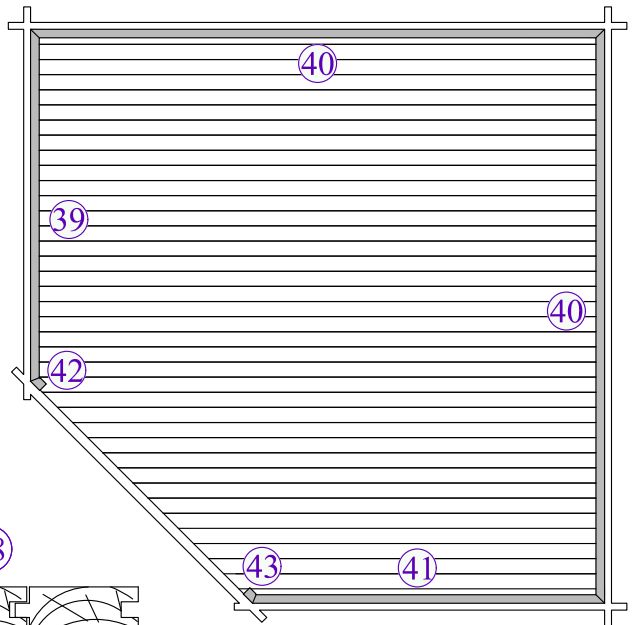
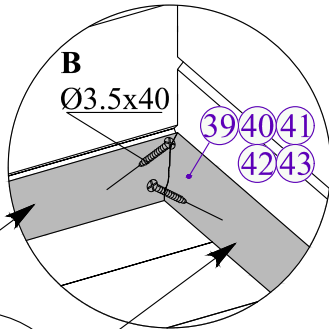
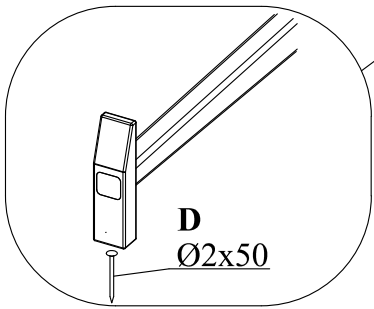
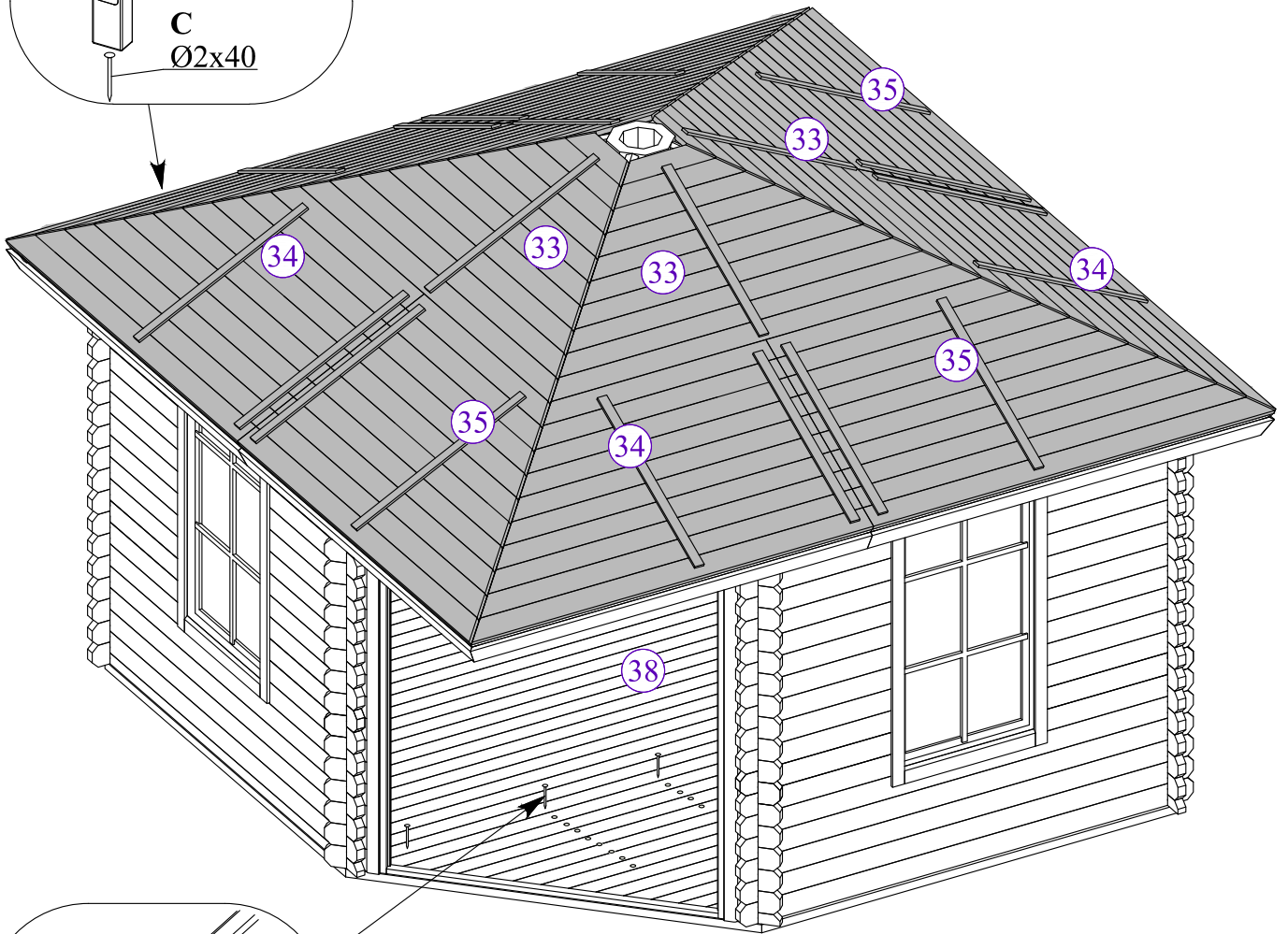
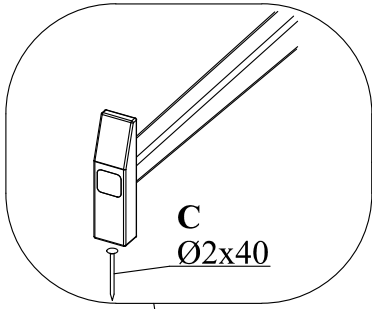

11 / 11  
→ || ← 28mm

2,6 x 2,6

28028

