

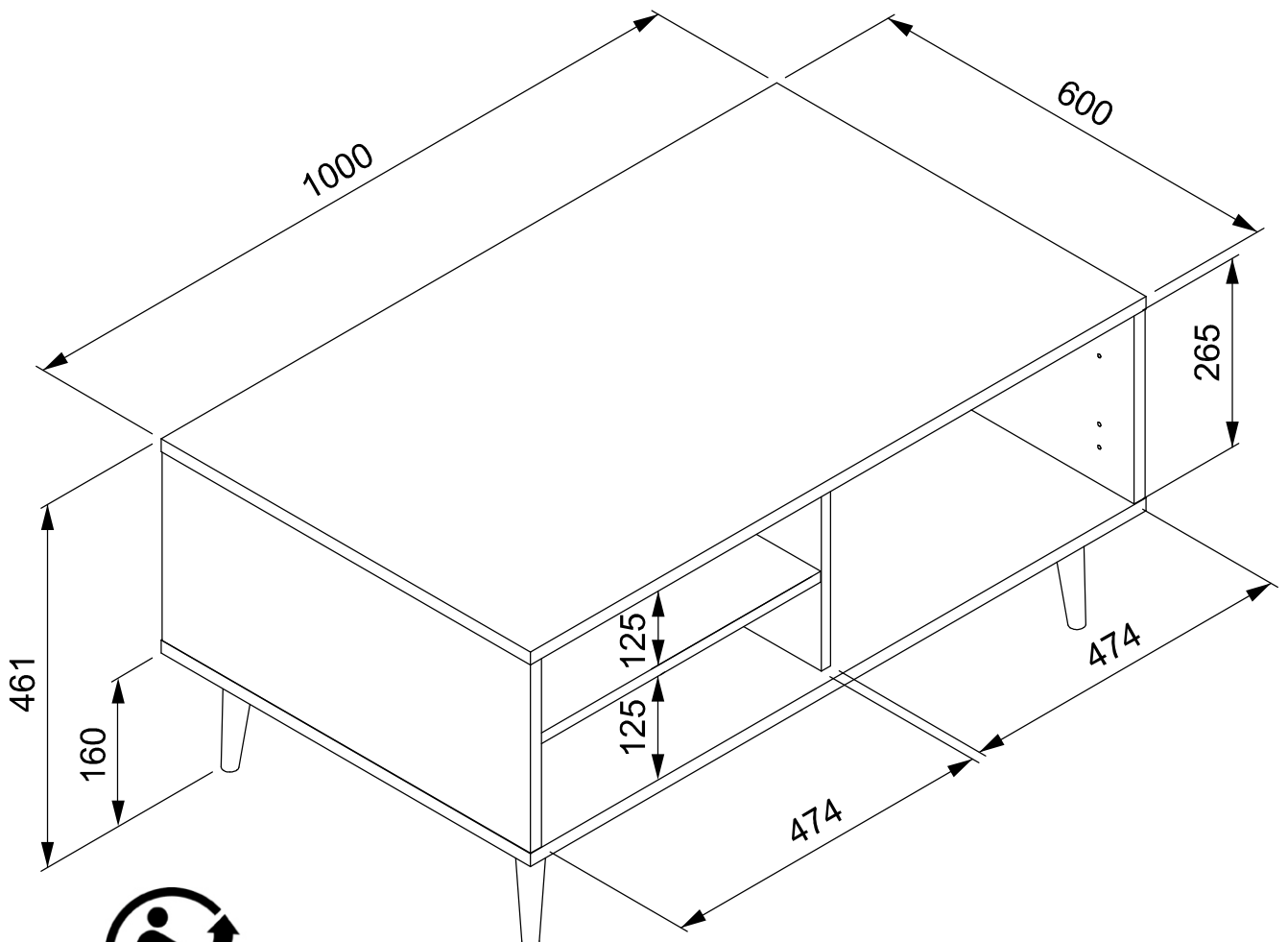

BLI55A/196

finori GmbH
Straßäcker 2
D - 96253 Untersiemau

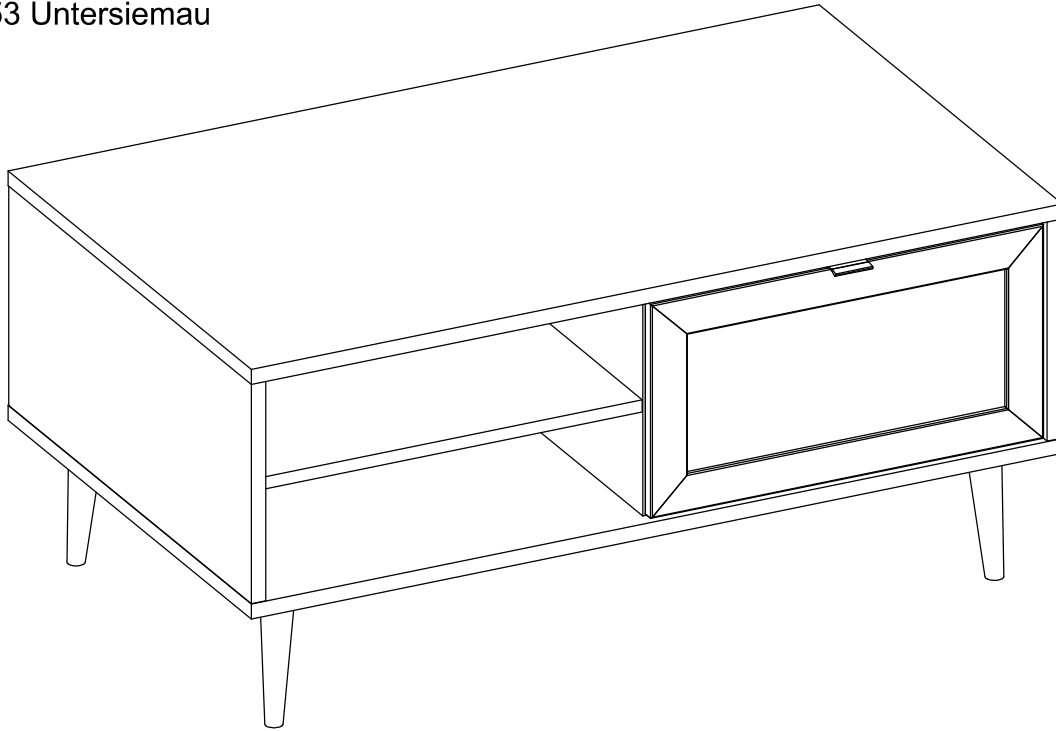



- Ⓓ Befolgen Sie stets die Anleitung des Herstellers!
- ⒸⒹ Please generally follow the manufacturer's instructions!
- ⒻⒼ Suivez toujours les instructions du fabricant!
- ⒹⒻ Volg steeds de handleiding van de producent!
- ⒺⒾ Siga siempre las instrucciones del fabricante!
- ⒹⒶ Stale przestrzegaj instrukcji producenta!

- ⒹⒶ Всегда следуйте инструкции производителя!
- ⒹⒶ Seguire sempre le istruzioni del produttore!
- ⒹⒶ Mindig tartsa be a gyártó utasításait!
- ⒹⒶ Siga sempre as instruções do fabricante!
- ⒹⒶ Vždy dodržujte pokyny výrobce!

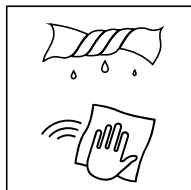

- Ⓓ Verwenden Sie zur Reinigung nur ein feuchtes Tuch!
- ⒸⒹ Please only clean with a damp cloth!
- ⒻⒼ N'utilisez qu'un chiffon humide pour le nettoyage!
- ⒹⒻ Gebruik voor de reiniging enkel een vochtige doek!
- ⒺⒾ Para limpiar utilice sólo un paño húmedo!
- ⒹⒶ Do czyszczenia używaj wilgotnej szmatki!

- ⒹⒶ Для очистки используйте только влажную ткань!
- ⒹⒶ Per la pulizia, utilizzare solo un panno umido!
- ⒹⒶ A tisztításhoz elegendő egy nedves kendő használatát!
- ⒹⒶ Para a limpeza use apenas um pano húmido!
- ⒹⒶ Pro čištění používejte pouze vlhký hadřík!

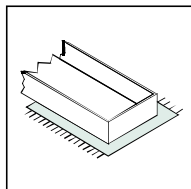

- Ⓓ Bauen Sie das Produkt auf einer Unterlage auf!
- ⒸⒹ Please mount the product on a bottom support!
- ⒻⒼ Montez le produit sur une base!
- ⒹⒻ Monteer het product op een basis!
- ⒺⒾ Monte el producto sobre una base!
- ⒹⒶ Rozkładaj produkt na podkładce!

- ⒹⒶ Собирайте изделие на подстилке!
- ⒹⒶ Montare il prodotto su un supporto!
- ⒹⒶ Az összeszereléskor helyezzen a termék alá megfelelő alátétet!
- ⒹⒶ Monte o produto numa superfície plana!
- ⒹⒶ Výrobek smontujte na pevném podkladu!

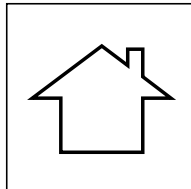

- Ⓓ Verwenden Sie das Produkt nur in Innenräumen!
- ⒸⒹ Please exclusively use the product indoors!
- ⒻⒼ N'utilisez le produit qu'à l'intérieur!
- ⒹⒻ Gebruik het product enkel binnenshuis!
- ⒺⒾ Utilice el producto sólo en interiores!
- ⒹⒶ Używaj produkt tylko w pomieszczeniach wewnętrznych!

- ⒹⒶ Используйте изделие только во внутренних помещениях!
- ⒹⒶ Utilizzare il prodotto solo in ambienti interni!
- ⒹⒶ A termék csak bel terekben használható!
- ⒹⒶ Use o produto apenas no interior!
- ⒹⒶ Používejte výrobek pouze uvnitř!

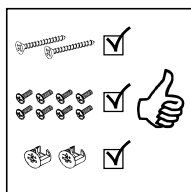

- Ⓓ Legen Sie die Beschläge zusammen und prüfen Sie die Vollständigkeit!
- ⒸⒹ Please join the fittings and verify their completeness!
- ⒻⒼ Pliez les raccords ensemble et vérifiez qu'ils sont complets!
- ⒹⒻ Leg de onderdelen samen en controleer de volledigheid!
- ⒺⒾ Junte los accesorios y compruebe que están todos!
- ⒹⒶ Rozlož poszczególne części i sprawdź kompletność!

- ⒹⒶ Положите фурнитуру в одно место и проверьте комплектность!
- ⒹⒶ Mettere insieme le guarnizioni e verificarne la completezza!
- ⒹⒶ Állítsa össze a sarokvasakat, és ellenőrizze, hogy épek-e!
- ⒹⒶ Coloque os encaixes juntos e verifique se estão completos!
- ⒹⒶ Složte armatury a zkontrolujte úplnost!

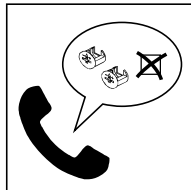

- Ⓓ Bei fehlenden Teilen kontaktieren Sie den Hersteller!
- ⒸⒹ If parts are missing, please turn to the manufacturer!
- ⒻⒼ En cas de pièces manquantes, veuillez contacter le fabricant!
- ⒹⒻ Contacteer de fabrikant als er onderdelen ontbreken!
- ⒺⒾ En el caso de que falten piezas, póngase en contacto con el fabricante!
- ⒹⒶ W razie braku części skontaktuj się z producentem!

- ⒹⒶ При отсутствии каких-либо частей обратитесь к производителю!
- ⒹⒶ In caso di pezzi mancanti, contattare il produttore!
- ⒹⒶ Ha hiányozna valamelyik elem, lépjen kapcsolatba a gyártóval!
- ⒹⒶ Em caso de peças em falta, entre em contato com o fabricante!
- ⒹⒶ Pro chybějící díly kontaktujte výrobce!

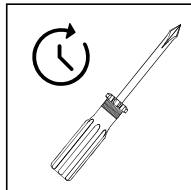

- Ⓓ Ziehen Sie die Schrauben nach einiger Zeit des Gebrauchs erneut fest!
- ⒸⒹ Please re-tighten the screws after having used the product for a while!
- ⒻⒼ Resserrer les vis après un certain temps d'utilisation!
- ⒹⒻ Draai de schroeven na een zekere gebruikstijd opnieuw vast!
- ⒺⒾ Asegure de nuevo los tornillos tras usarlo durante un tiempo!
- ⒹⒶ Po pewnym czasie użytkowania ponownie dokręć śruby!

- ⒹⒶ Спустя некоторое время использования подкрутите гайки!
- ⒹⒶ Stringere nuovamente le viti dopo un certo periodo di utilizzo!
- ⒹⒶ A használat során némi idő elteltével húzza meg újra a csavarokat!
- ⒹⒶ Reaperte os parafusos após algum tempo de uso!
- ⒹⒶ Po určité době používání šrouby znovu utáhněte!



BLI55A/196

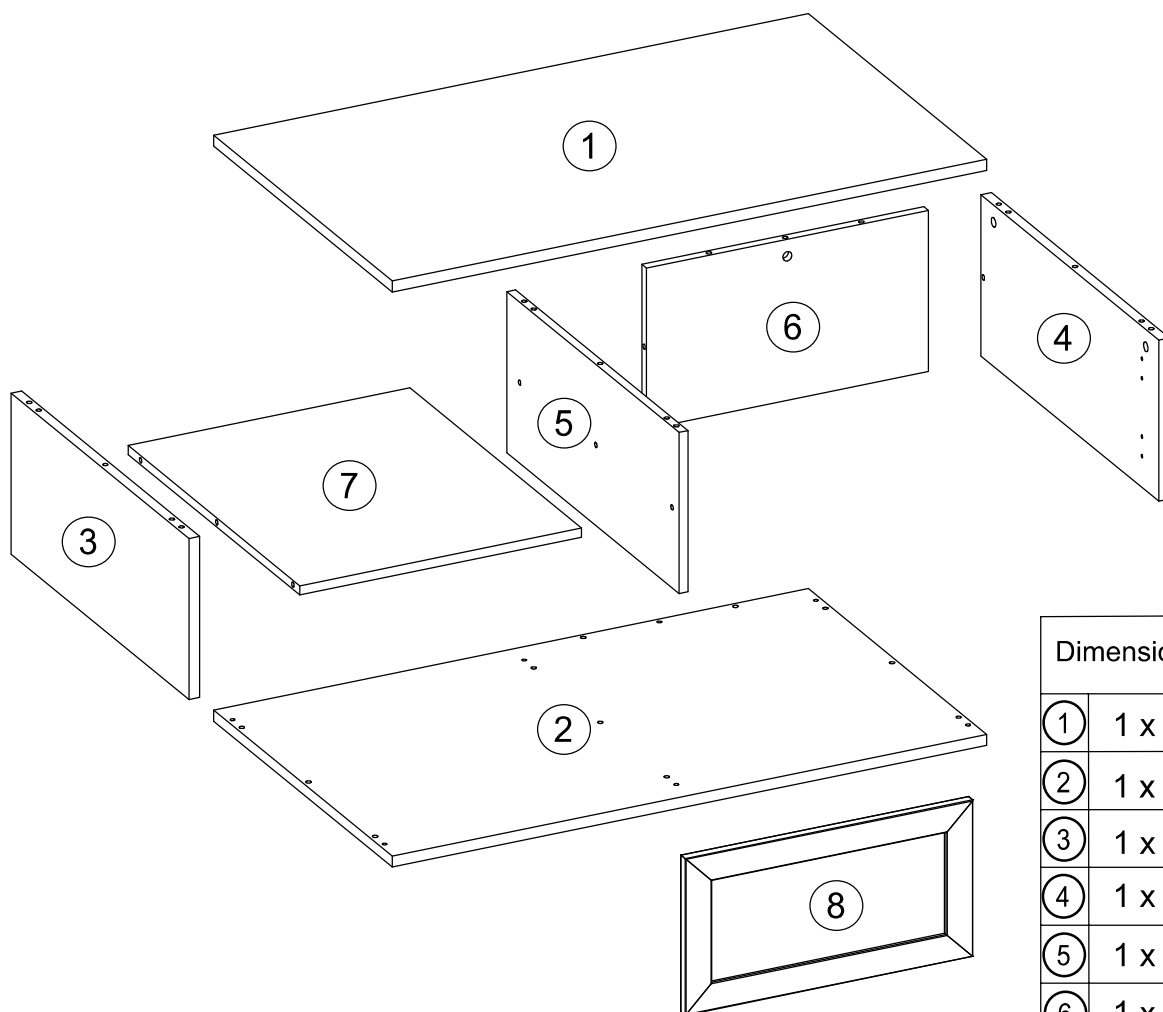
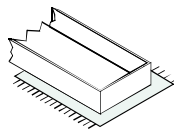
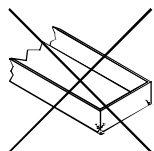
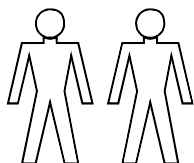
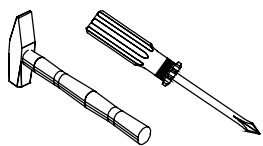

Dimensions / Abmessung in mm/

①	1 x	1000 x 600 x 18
②	1 x	1000 x 600 x 18
③	1 x	598 x 265 x 18
④	1 x	598 x 265 x 18
⑤	1 x	579 x 265 x 16
⑥	1 x	474 x 265 x 16
⑦	1 x	577 x 474 x 16
⑧	1 x	484 x 258 x 16

BOX 1

1, 2, 3, 4, 5, 6, 7, 8

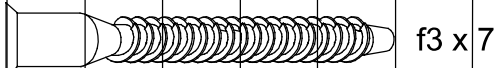

BOX 1

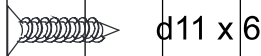
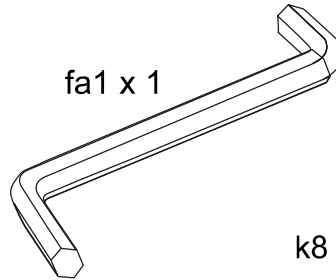
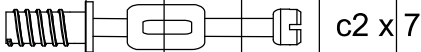
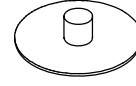
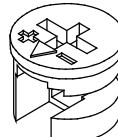

k8 x 2

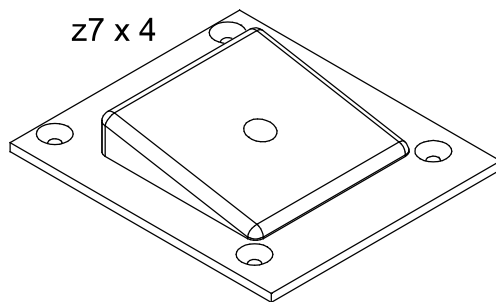
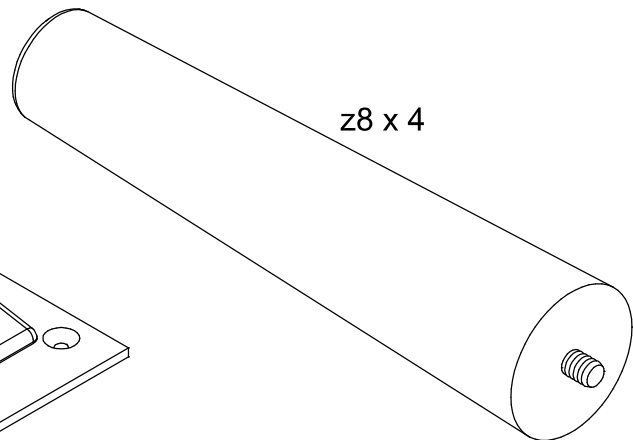
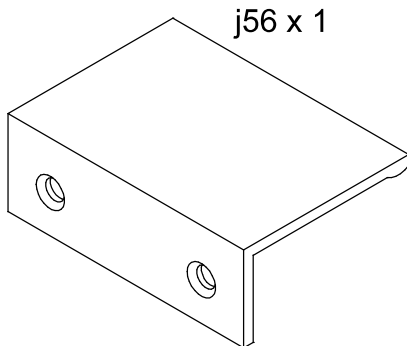
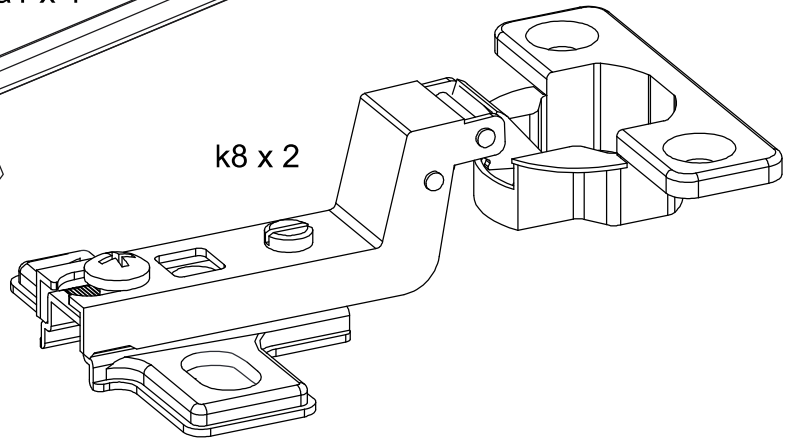

A

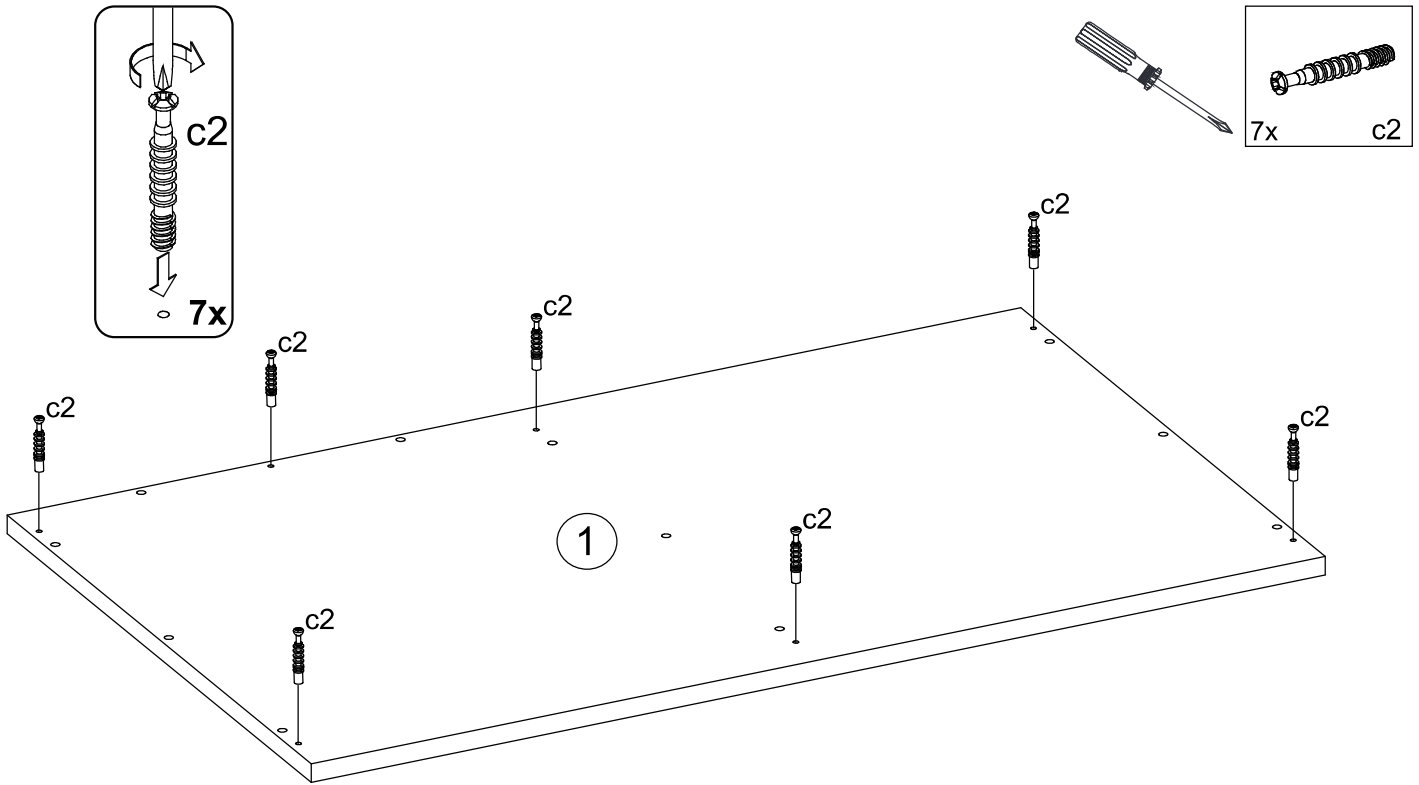

B

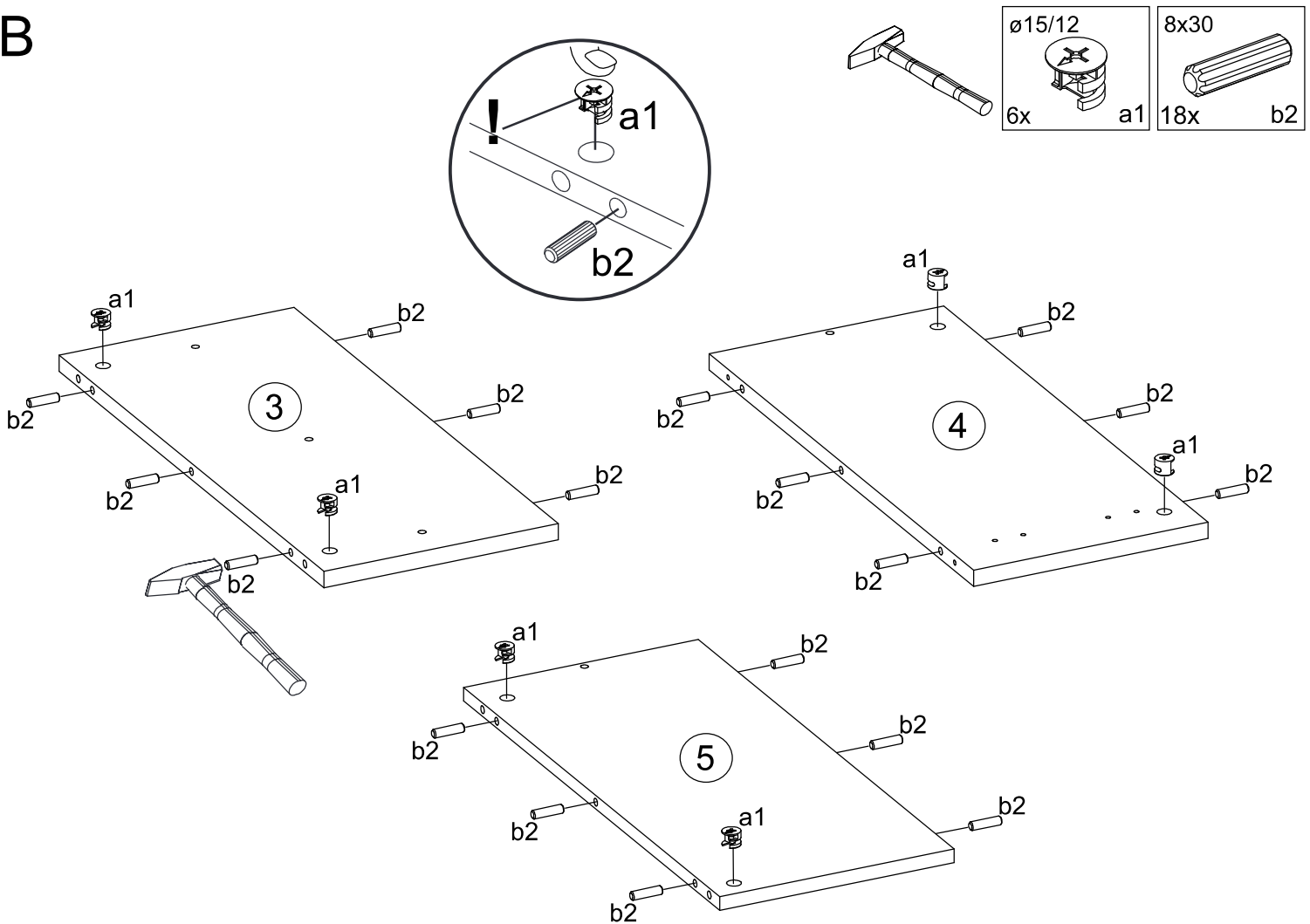

C

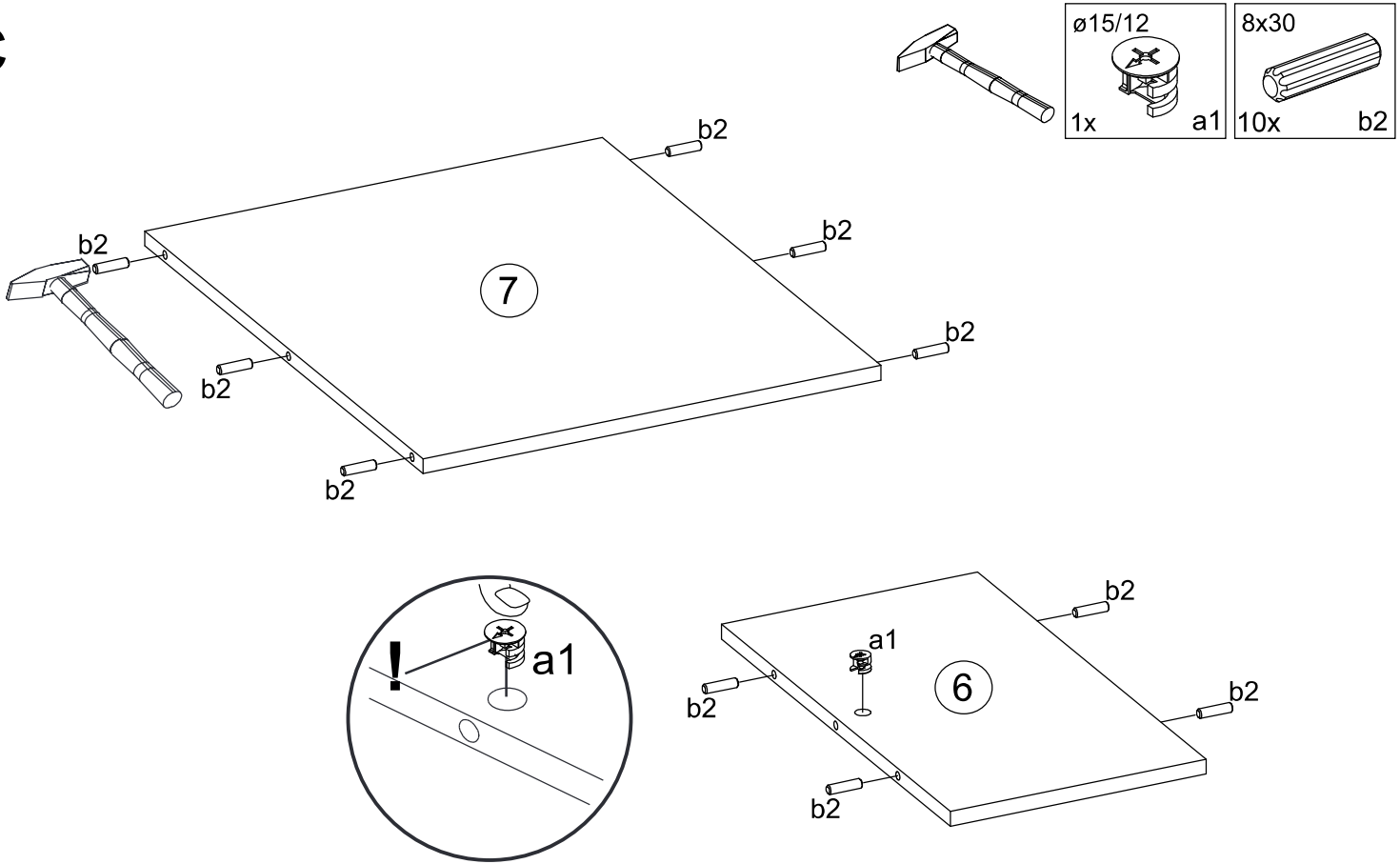

D

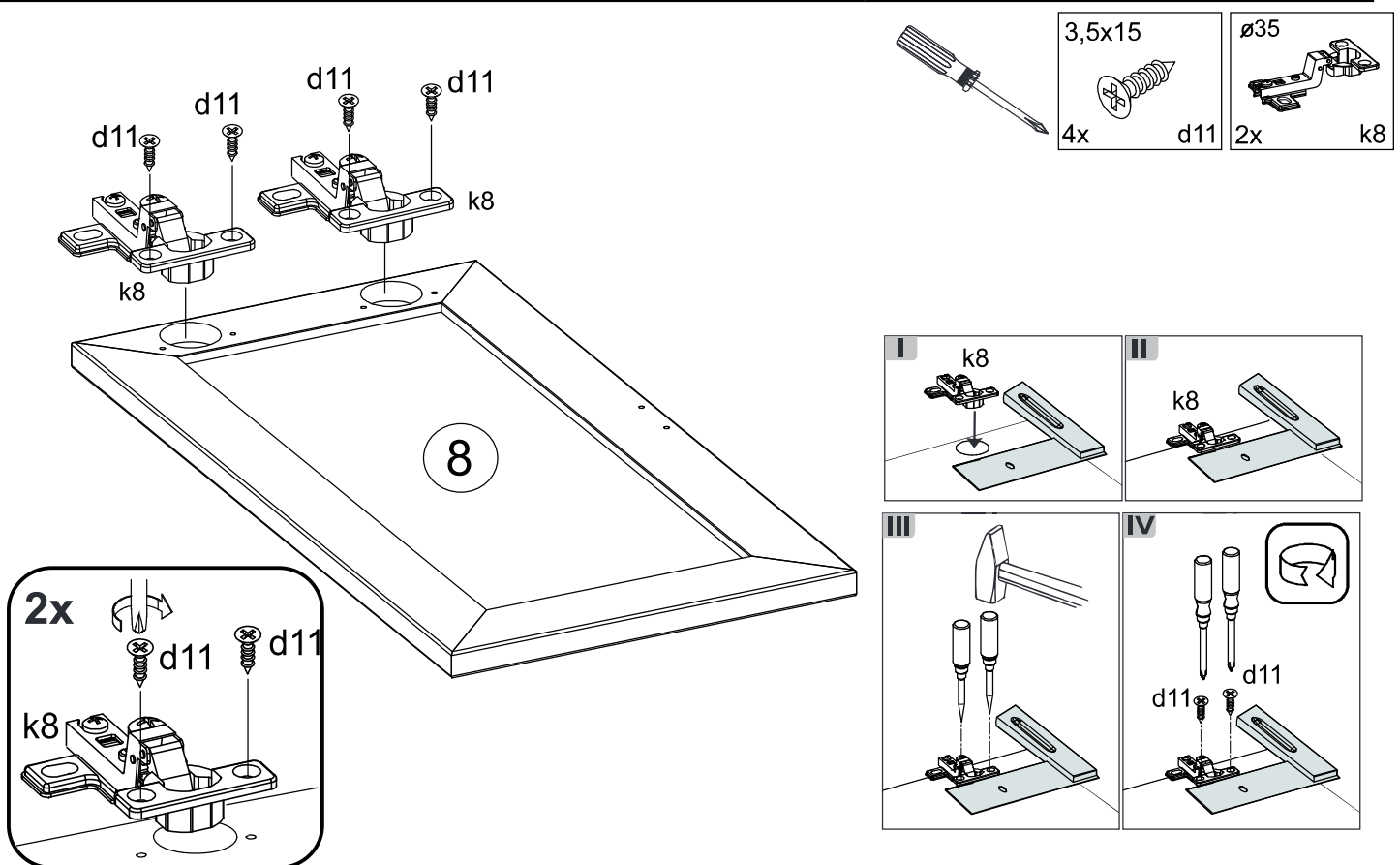

E

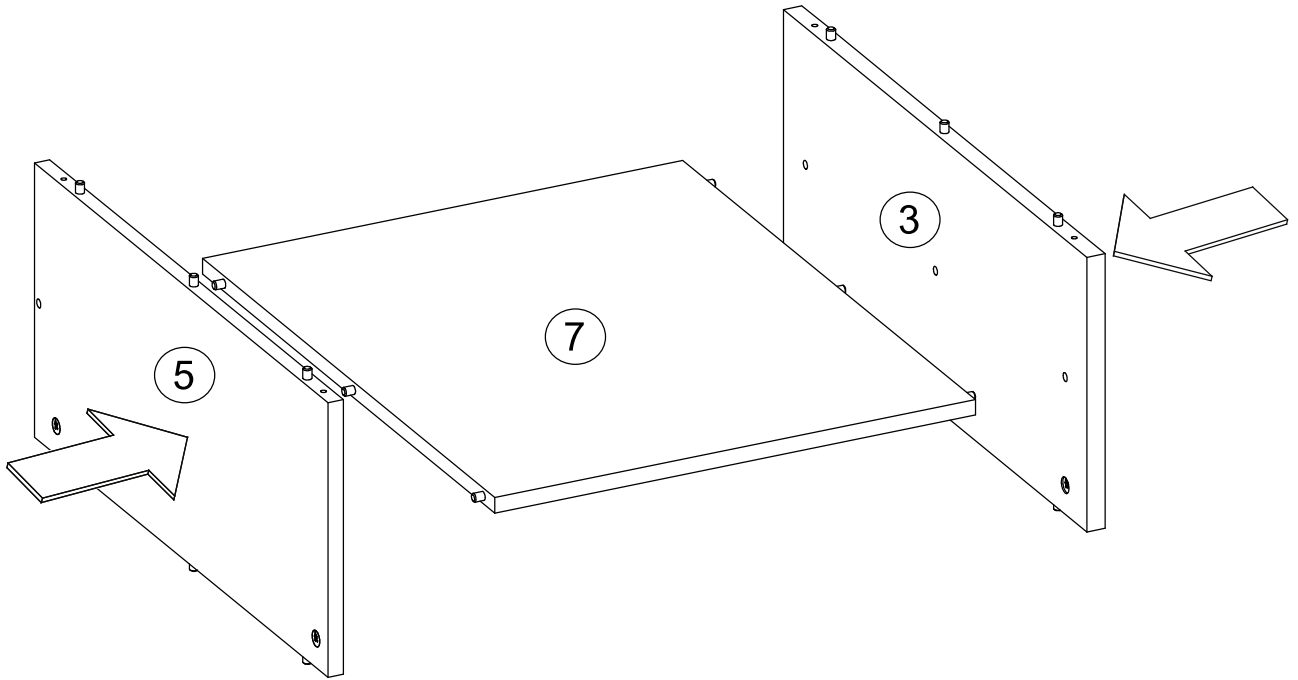

F

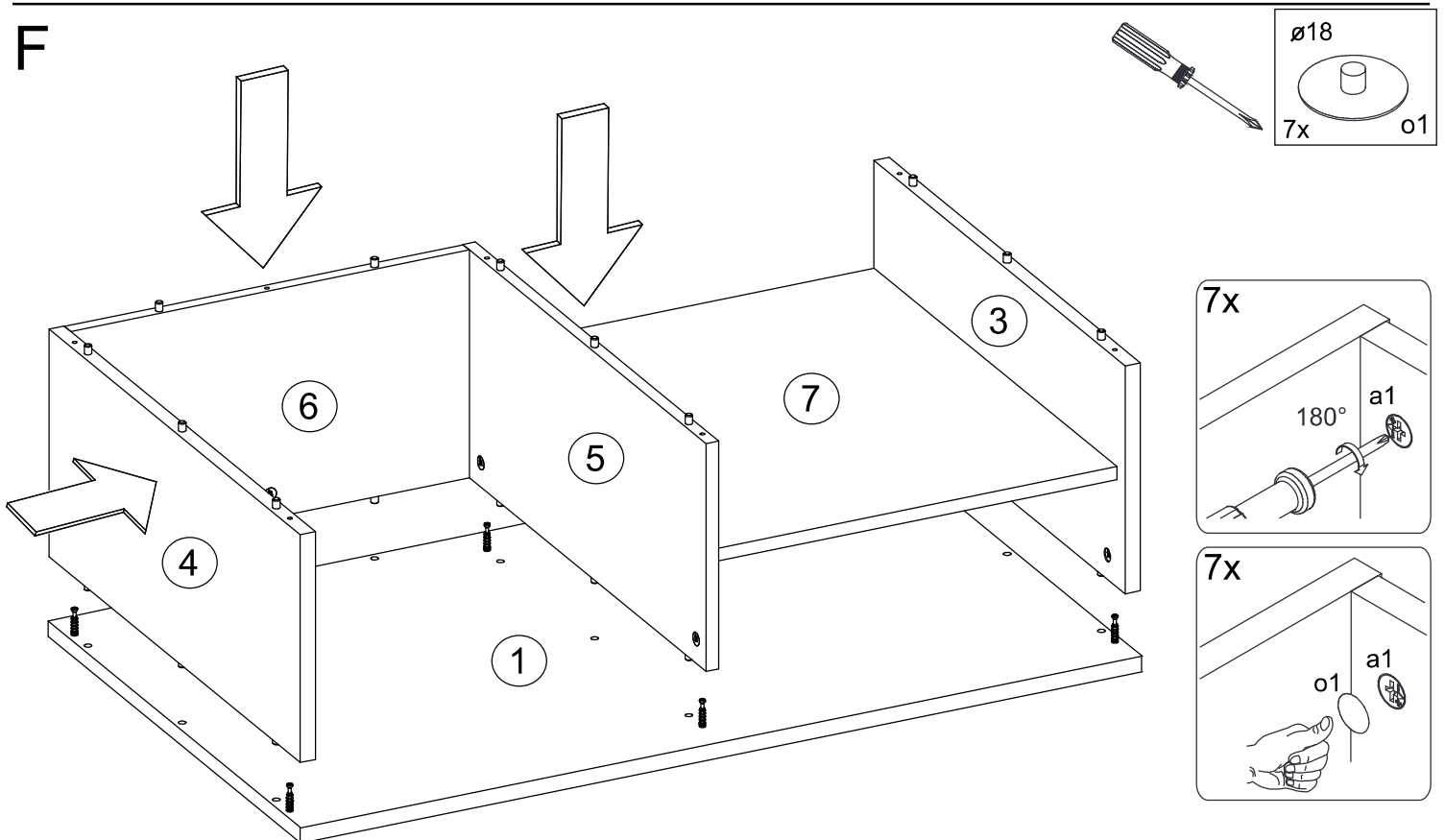

G

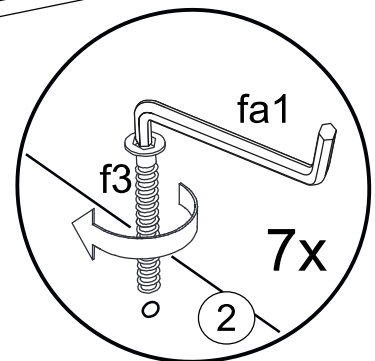
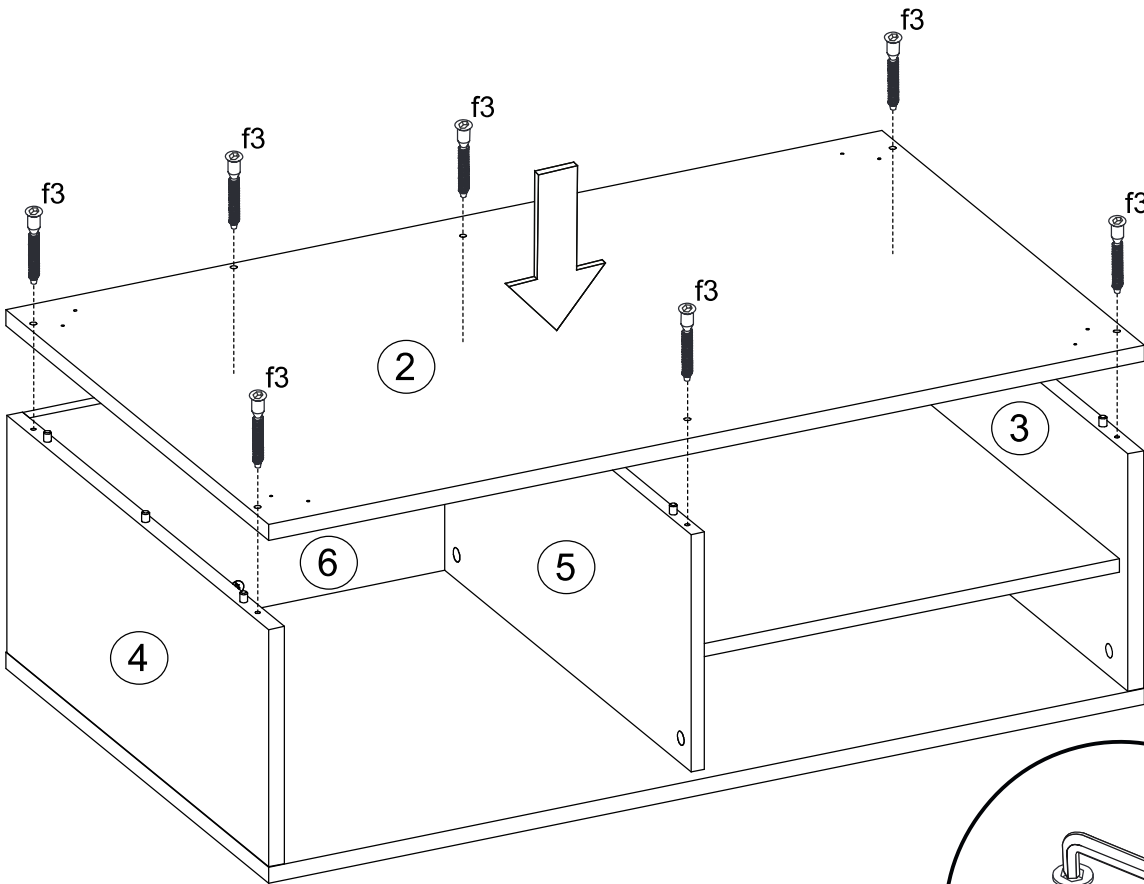
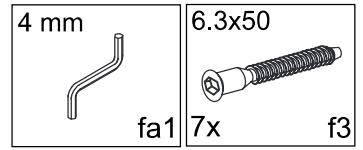

H

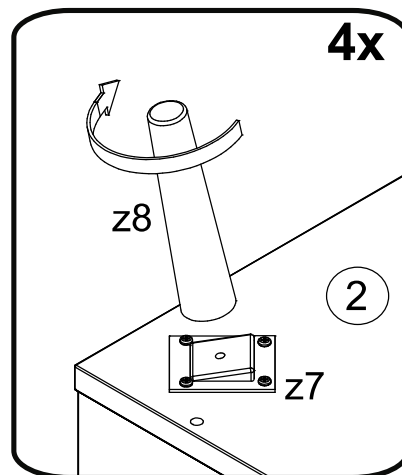
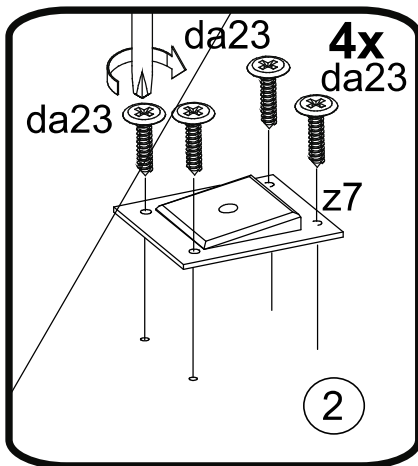
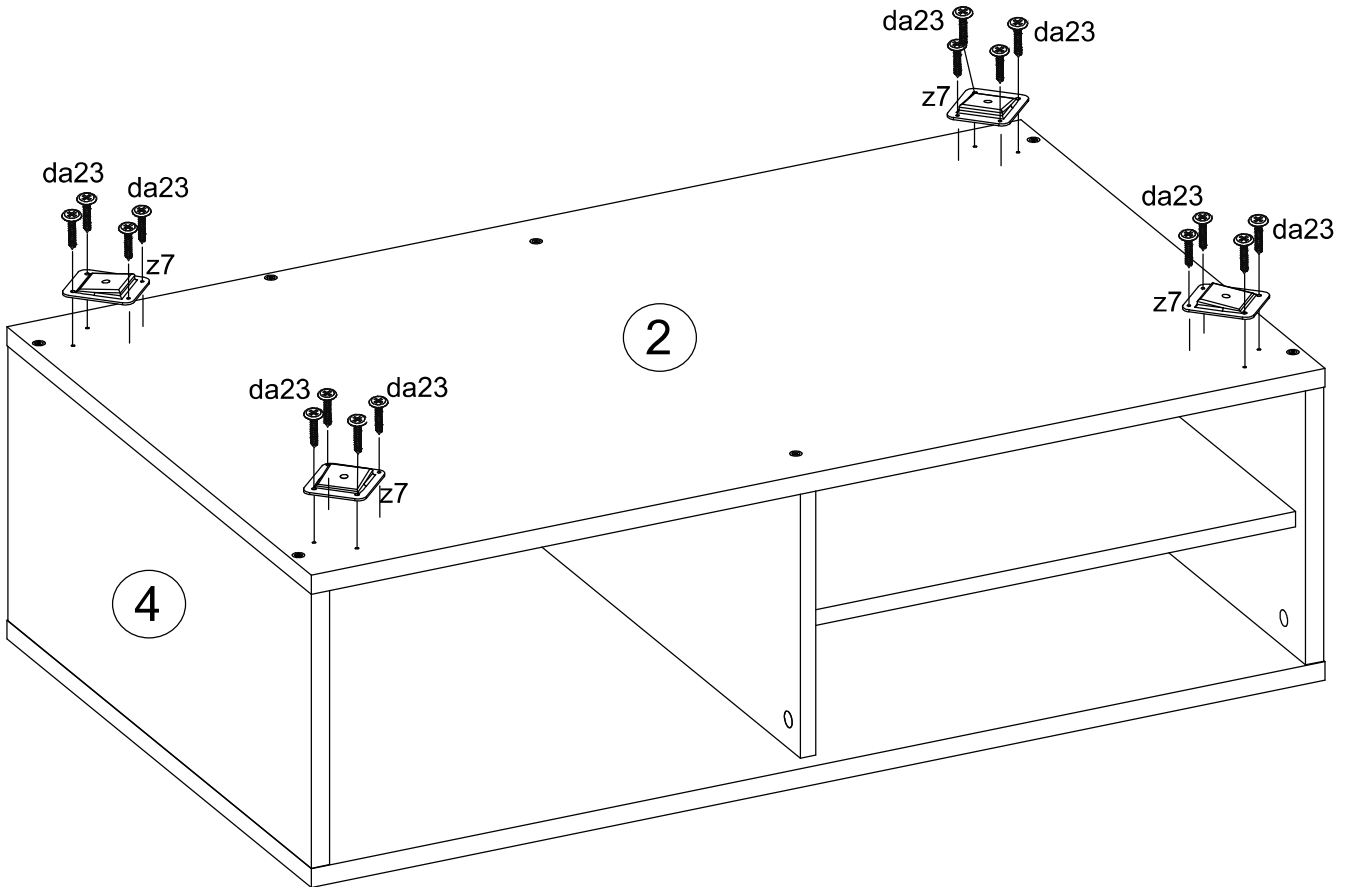
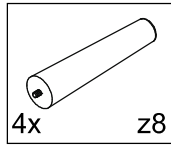
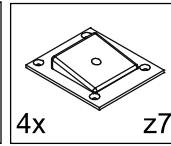
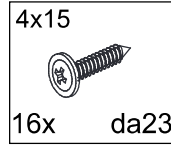

I

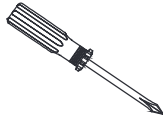

<p>6.3x13</p> <p>4x d5</p>	<p>3,5x15</p> <p>2x d11</p>	<p>1x j56</p>	<p>1x r5</p>
----------------------------	-----------------------------	---------------	--------------

