

# ASSEMBLY INSTRUCTIONS

## MONTAGEANLEITUNGEN

### N634P190867S/N634P190868S

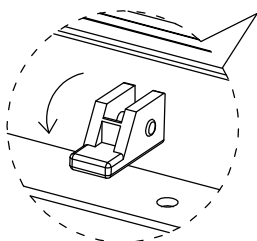
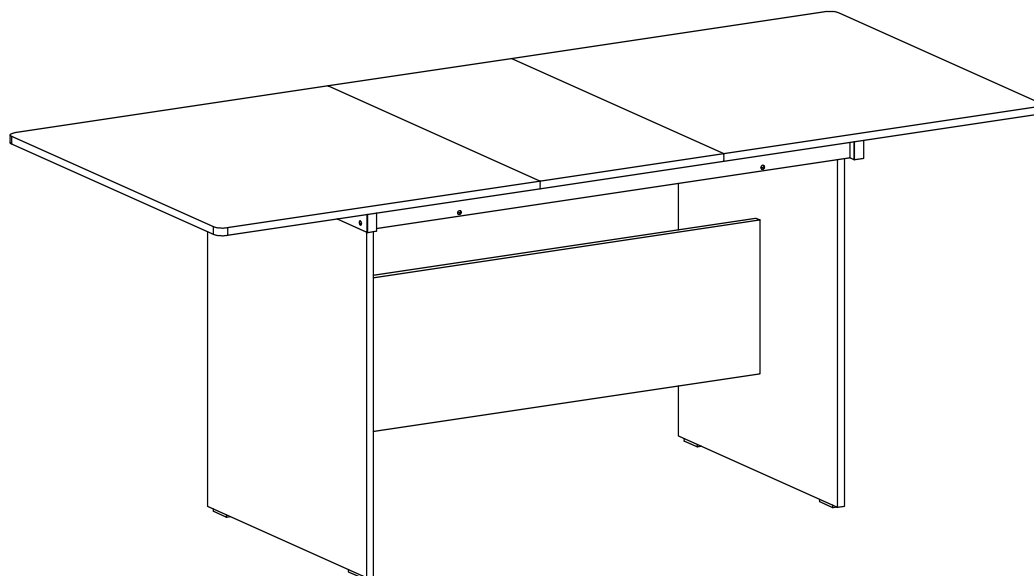

Lösen Sie die Verriegelung

Release the latch

Desserrer le loquet

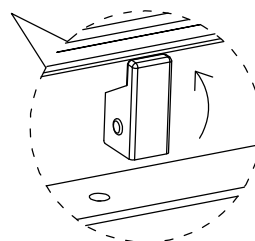
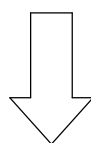



Verriegeln Sie die Verriegelung

Lock the latch

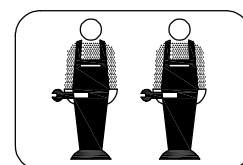
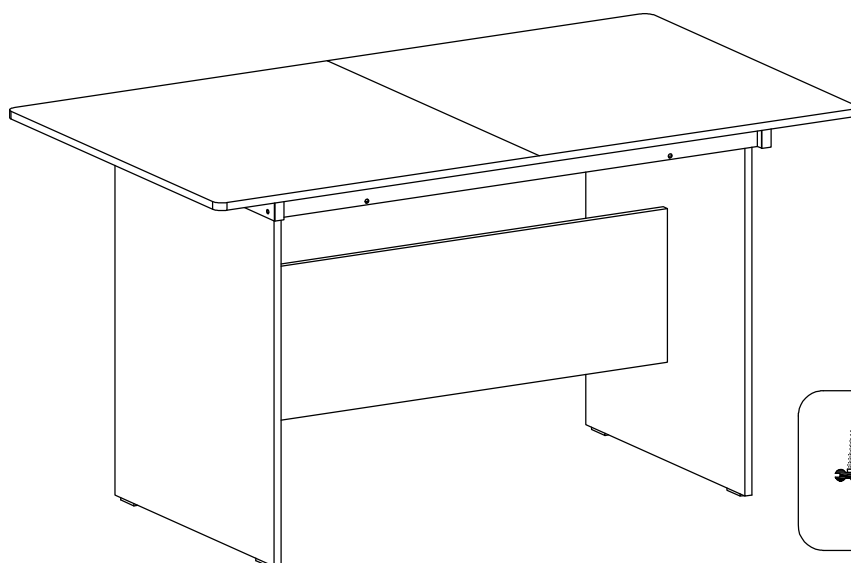
Verrouillé le loquet



 φ19x3mm	 φ18x1.8mm
Ⓜ ×4pcs	Ⓜ ×8pcs

Bitte beachten Sie, dass die Formen der Schrauben H und I ähnlich sind. Bitte installieren Sie entsprechend der Anleitung und unterscheiden Sie sie!

Please note that the shapes of screws H and I are similar. Please install according to the instructions and distinguish them!

Notez que les vis H et I ont des formes similaires. Veuillez les installer en suivant les instructions pour les séparer!

Vor dem Einbau die Schrauben in die Löcher stecken und festziehen, aber nicht bis 100%, 70% bis 80% anziehen reicht aus. Schließlich, nachdem alle Schrauben installiert sind, ziehen Sie alle Schrauben auf 100%. Wenn Sie auf diese Probleme stoßen, z.B. wenn die Löcher nicht ausgerichtet werden können oder einige Teile nicht installiert werden können, überprüfen Sie bitte, ob die Schrauben korrekt verwendet werden und passen Sie die Dichtheit der Schrauben an.

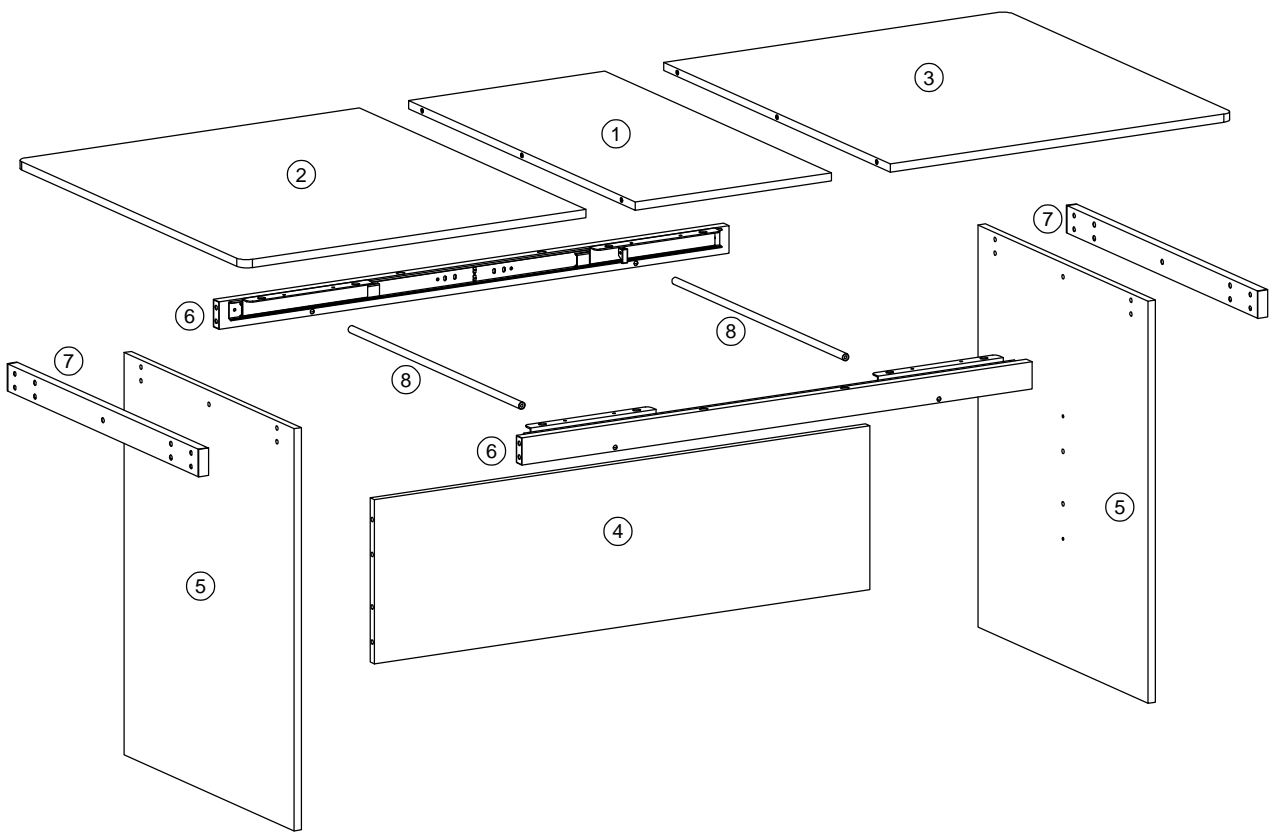

Before installation, insert the screws into the holes and tighten them, but do not tighten them to 100%, 70% to 80% is sufficient. Finally, after all screws are installed, tighten all screws to 100%. If you encounter these issues, such as if the holes cannot be aligned or some parts cannot be installed, please check if the screws are used correctly and adjust the tightness of the screws.

Insérer la vis dans le trou avant la fin de l'assemblage, serrer la vis, mais ne pas serrer à 100%, 70% ~ 80% est bien. Enfin, une fois que toutes les vis sont bien serrées, toutes les vis sont serrées à 100%. Si vous rencontrez ces problèmes, par exemple si les trous ne sont pas alignés ou si certaines pièces ne peuvent pas être montées, vérifiez que les vis sont utilisées correctement et ajustez leur serrage.



Part List  
Stückliste



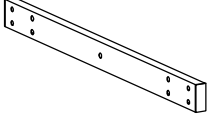
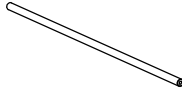



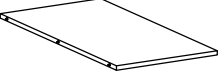
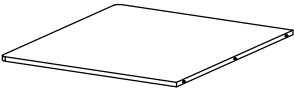
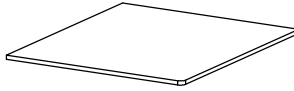
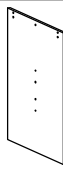

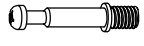

N634P190867S

			
④×1pc	⑥×2pcs	⑦×2pcs	⑧×2pcs

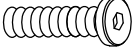

N634P190868S

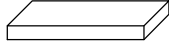
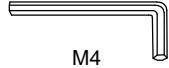
			
①×1pc	②×1pc	③×1pc	⑤×2pcs

Hardware List  
Hardwareliste

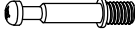

 φ6x35mm ①×4pcs	 φ15x12mm ②×4pcs	 φ8x30mm ③×4pcs	 M6×12mm ④×12pcs	 M6×28mm ⑤×10pcs
 M6×40mm ⑥×12pcs	 M6×17mm ⑦×10pcs	 φ19x3mm ⑧×4pcs	 φ18x1.8mm ⑨×8pcs	 ⑩×4pcs
 M4 ⑪×2pcs	 ⑫×1pc			

# Step 1 Schritt 1

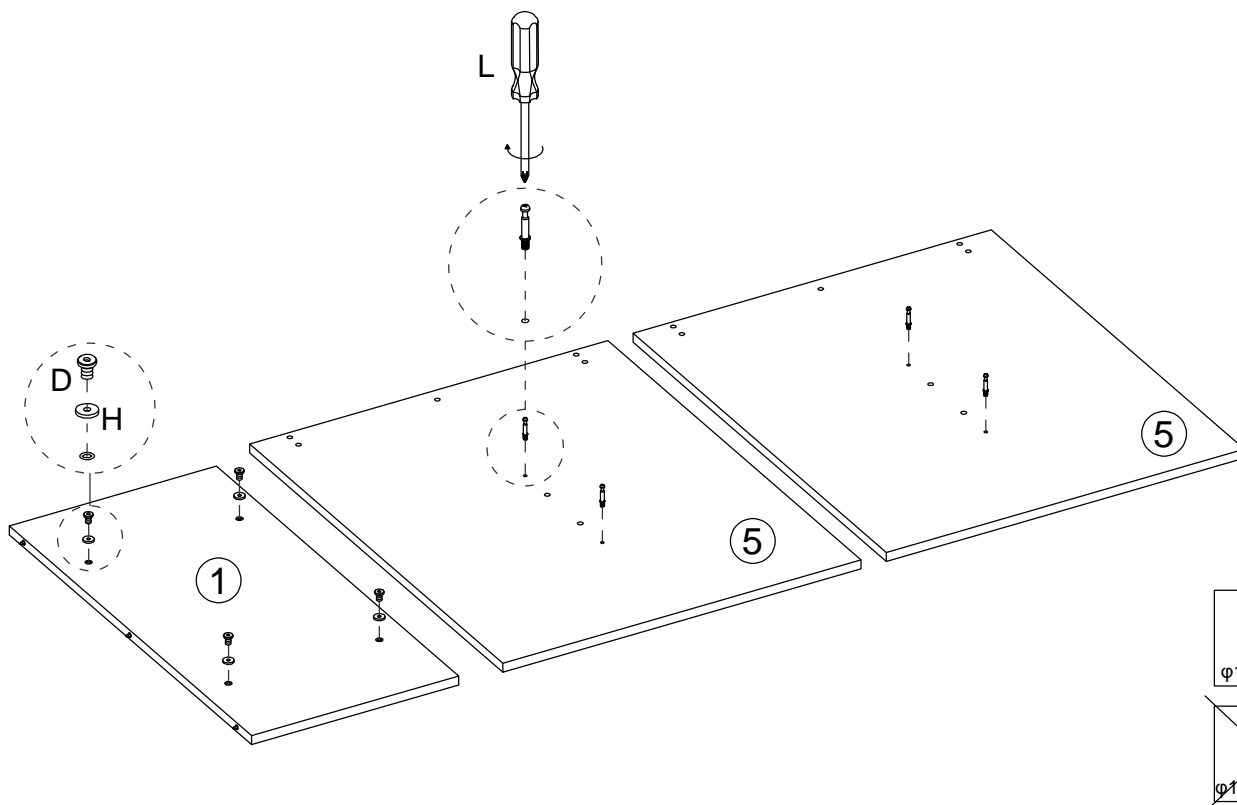
 φ6x35mm	 φ19x3mm	 M6x12mm
Ⓐ ×4pcs	Ⓗ ×4pcs	Ⓓ ×4pcs



# Step 2 Schritt 2

 φ15x12mm	 φ8x30mm
Ⓑ ×4pcs	Ⓒ ×4pcs

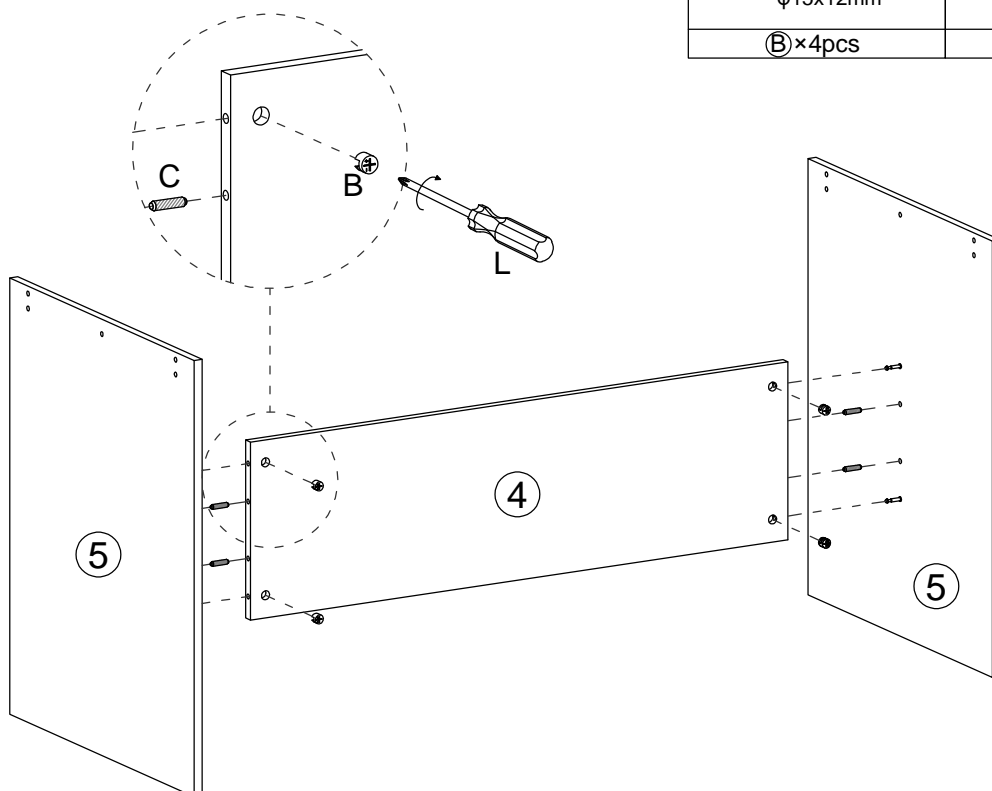

# Step 3 Schritt 3



M6x40mm

ⓕ×4pcs

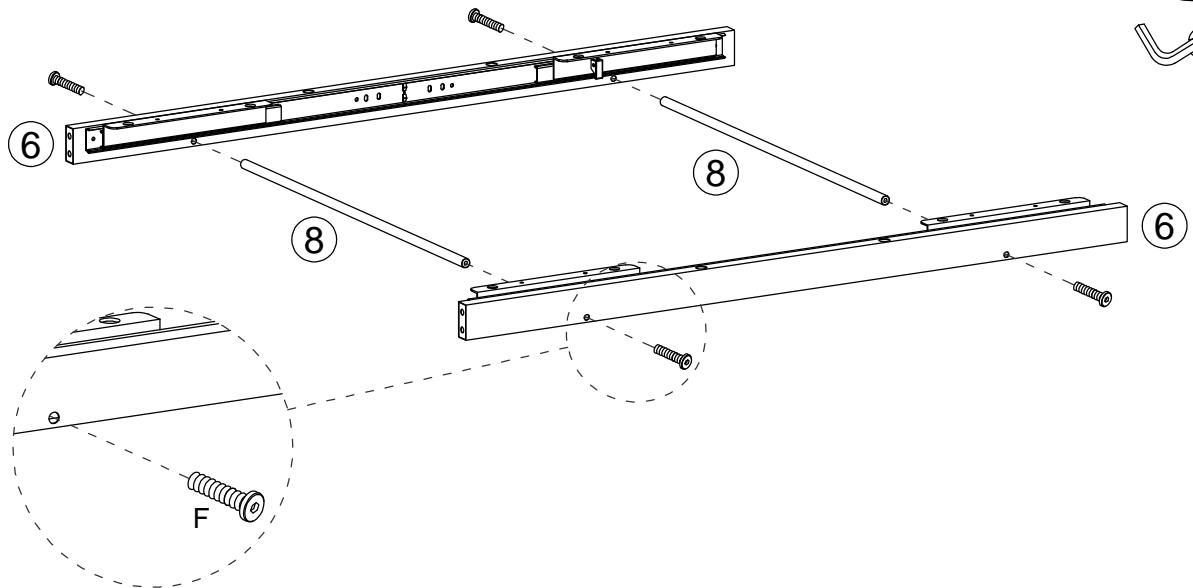

# Step 4 Schritt 4

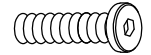

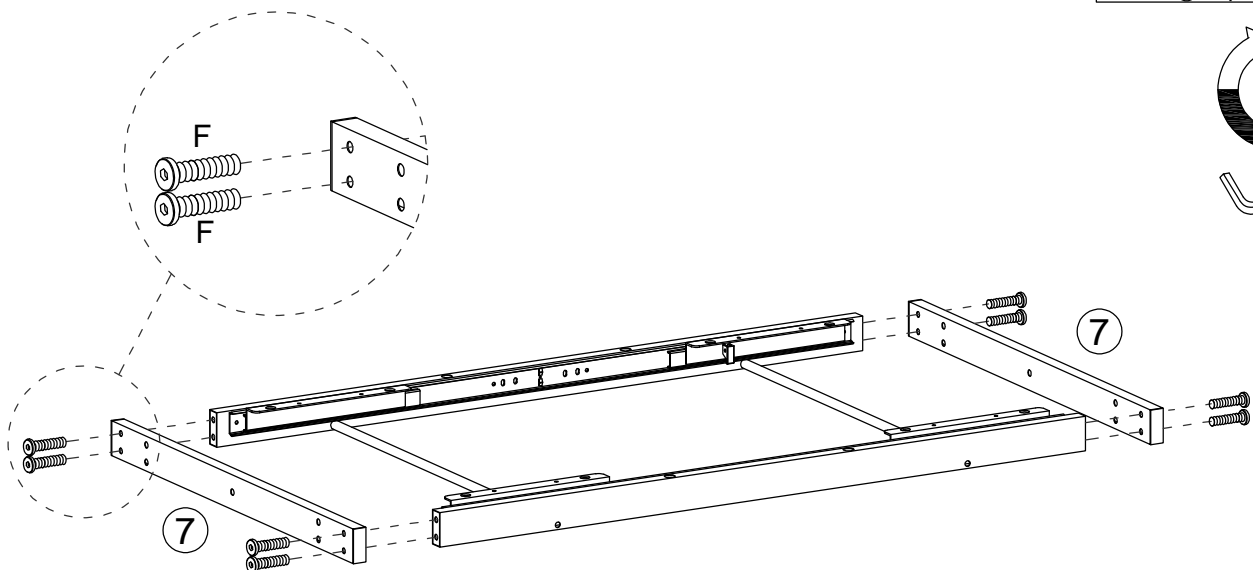
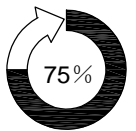

M6x40mm

ⓕ×8pcs



# Step 5 Schritt 5

 M6×17mm	 M6×28mm
Ⓒ ×10pcs	Ⓔ ×10pcs

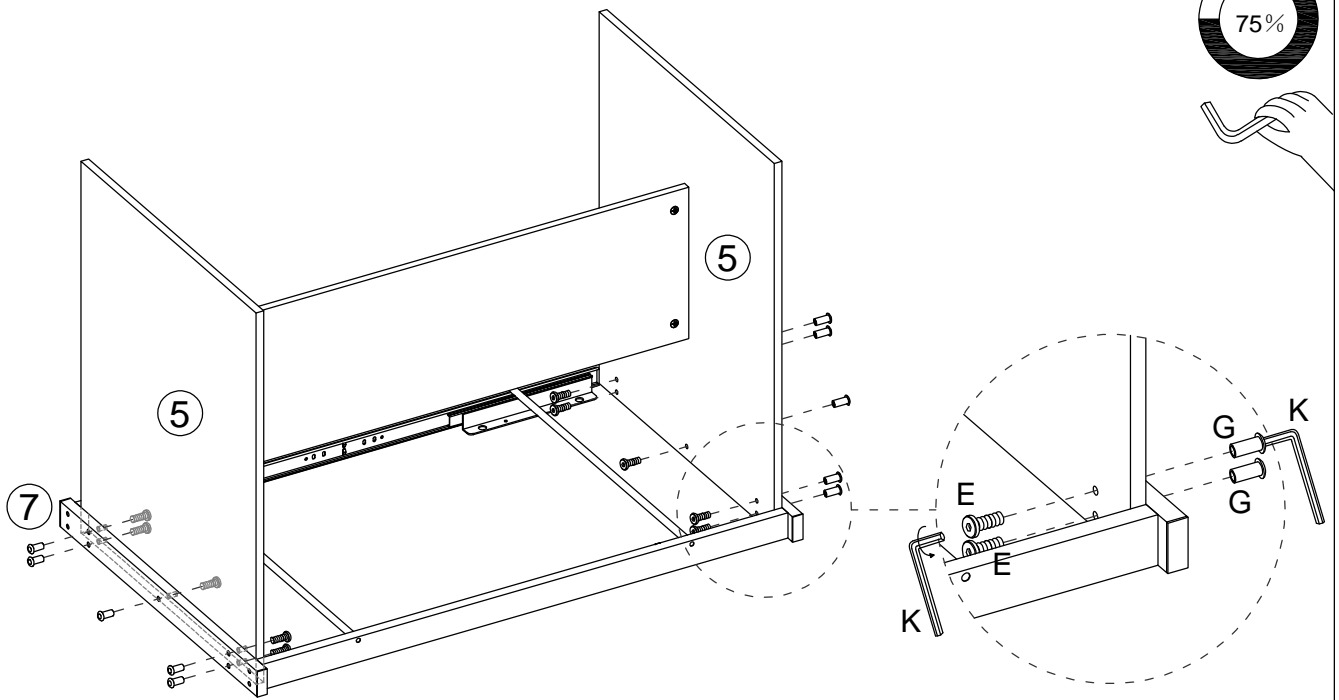
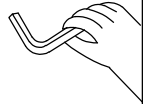

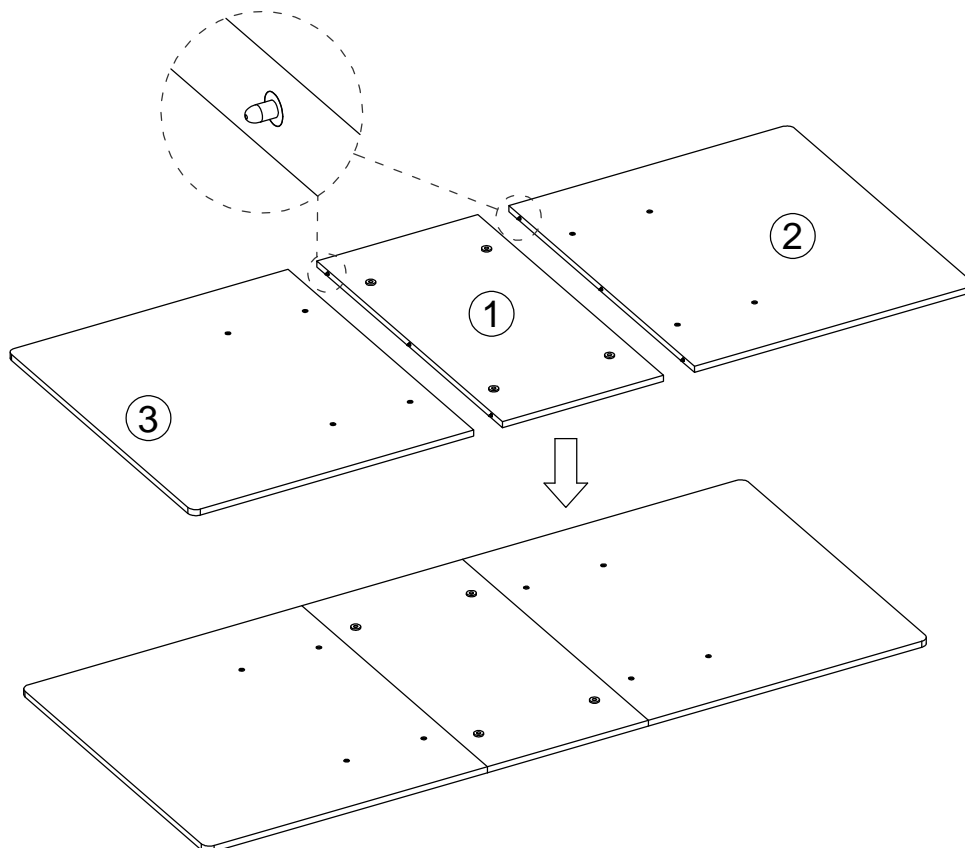

# Step 6 Schritt 6





# Step 7 Schritt 7

	
$\phi 18 \times 1.8 \text{mm}$	$M6 \times 12 \text{mm}$
Ⓛ × 8 pcs	Ⓧ × 8 pcs

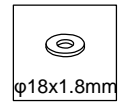
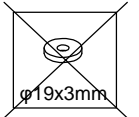
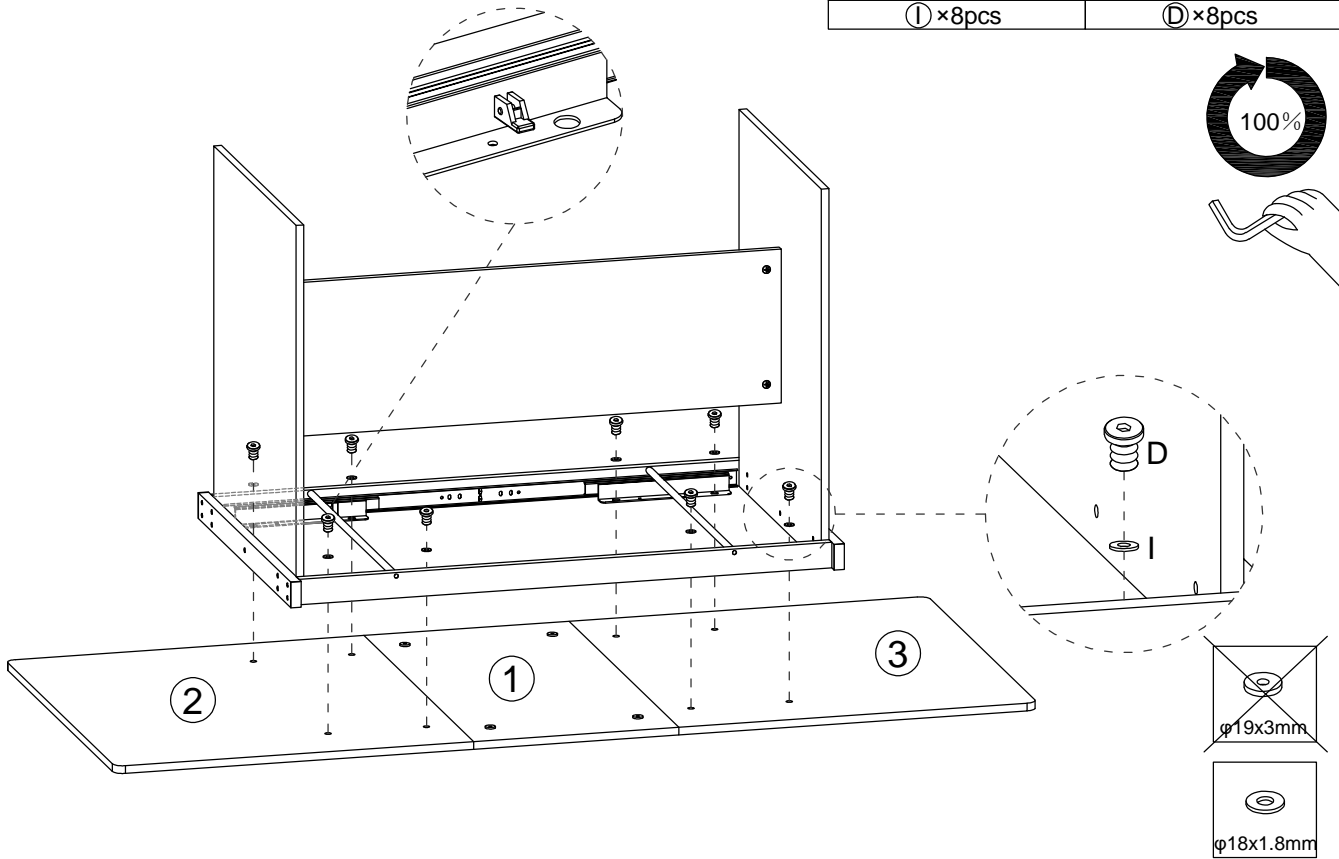

# Step 8 Schritt 8

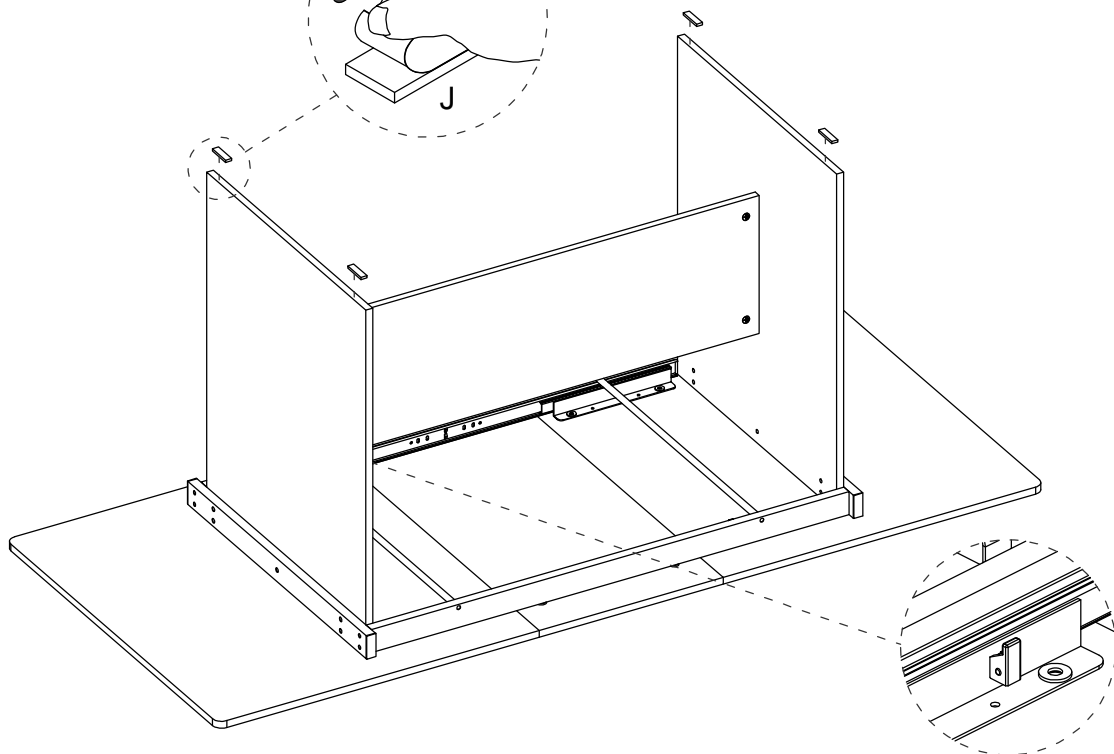
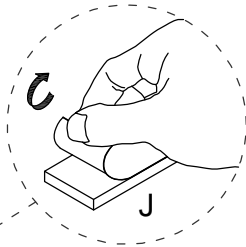

Ⓧ × 4 pcs

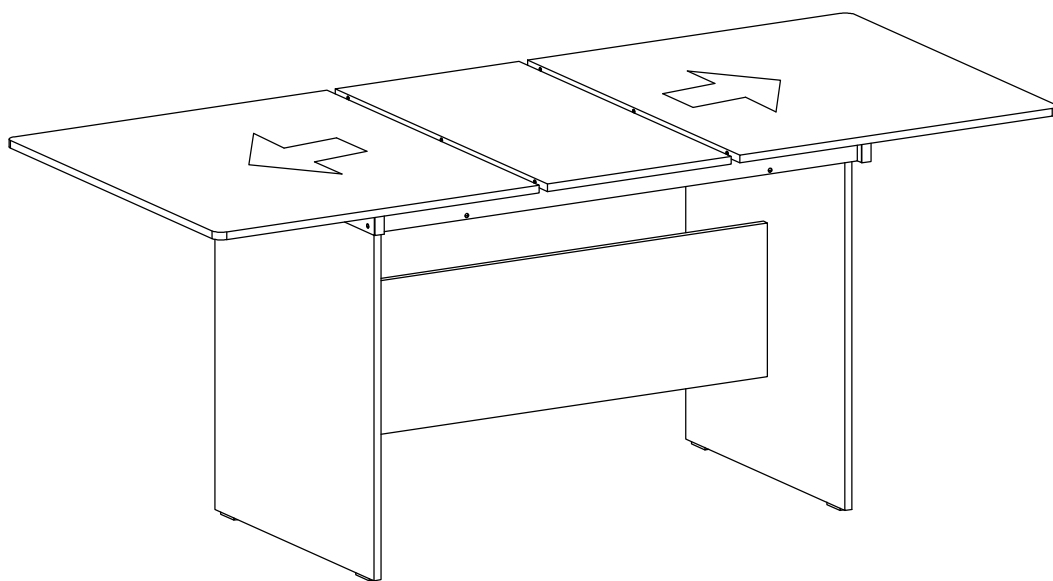
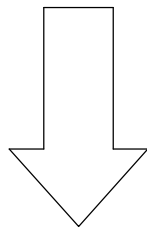
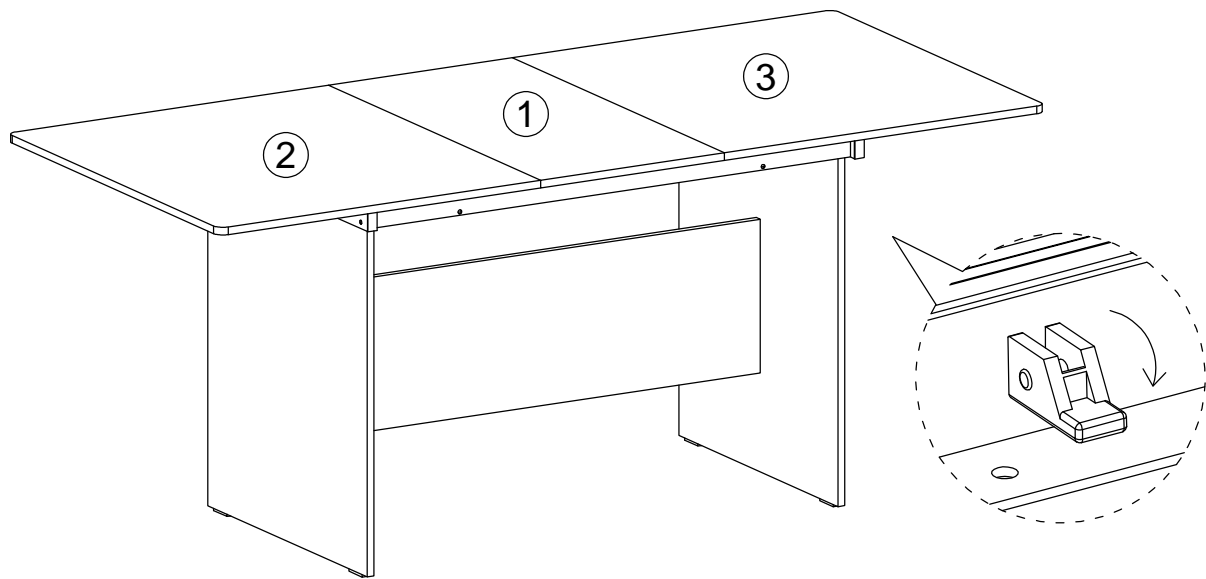

Step 9  
Schritt 9

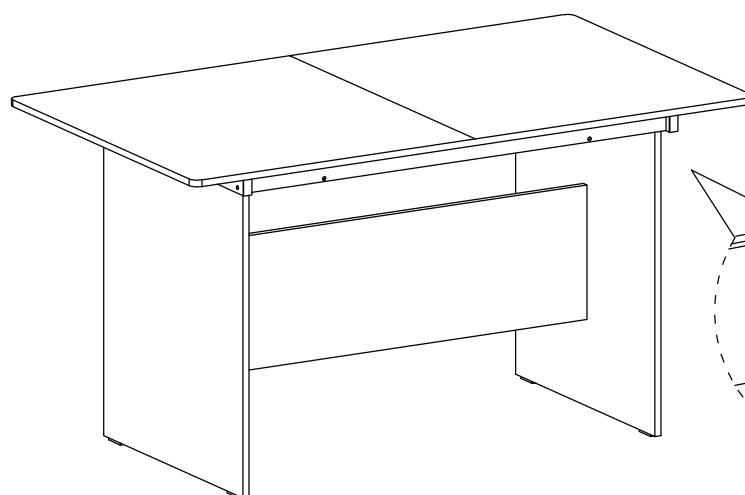
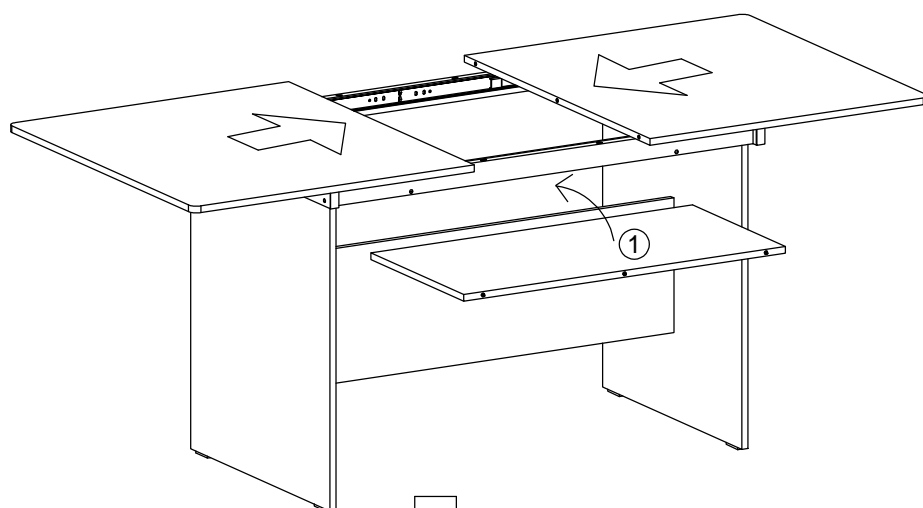
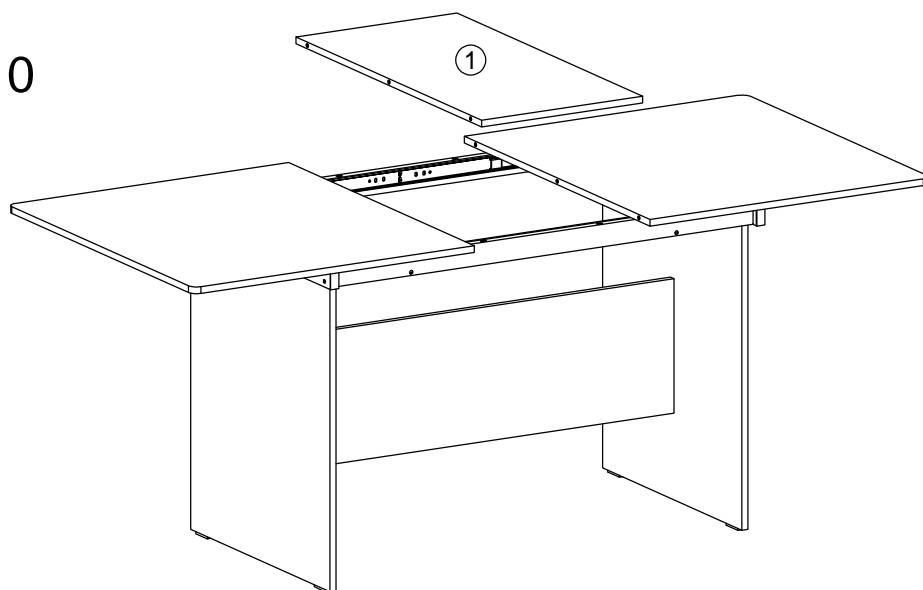

Step 10  
Schritt 10



Step 11  
Schritt 11

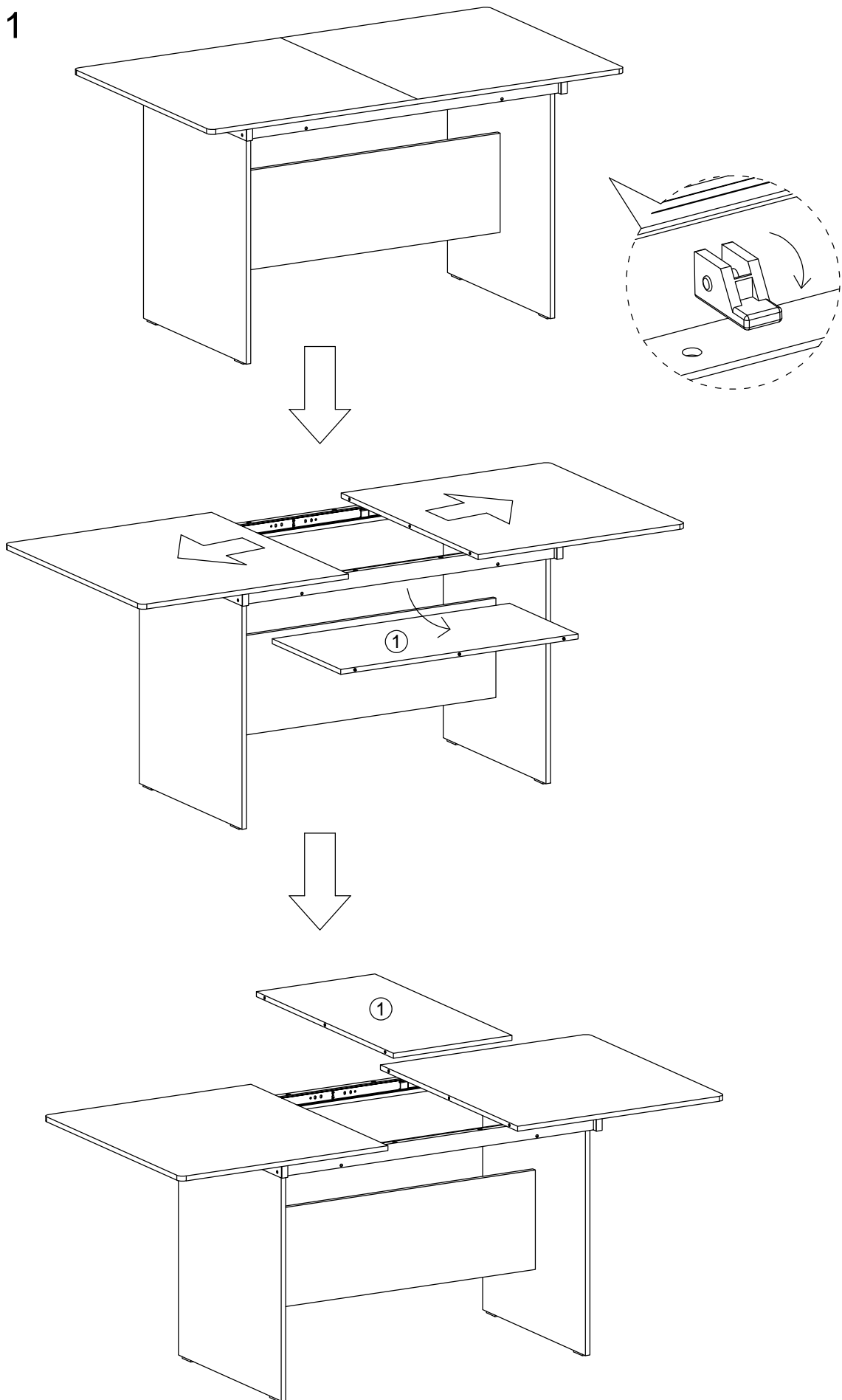

Step 12  
Schritt 12

