

Sideboard

Assembly Instructions / Montageanleitungen

WF307277 / WF307278

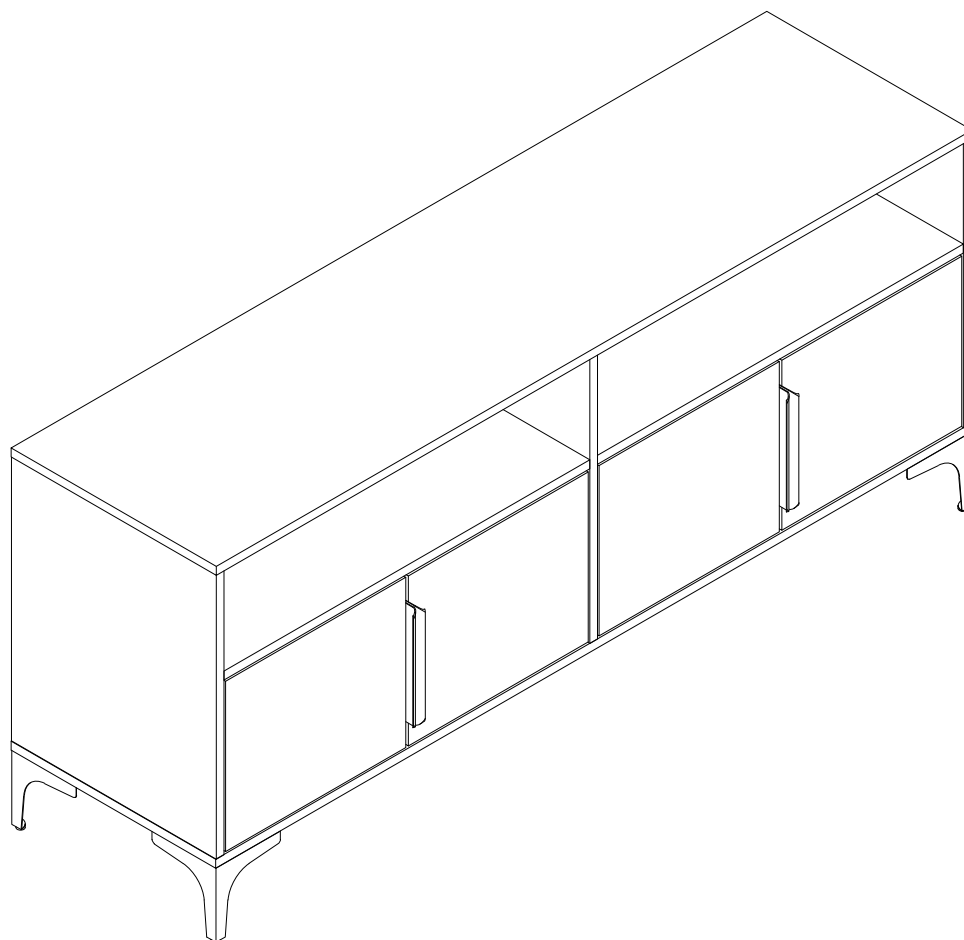

Dimensions

Width - 58inch
Depth - 15.7inch
Height - 25.2inch

Größe

Breite - 147.3cm
Tiefe - 40cm
Höhe - 64cm

Important – Please read these instructions fully before starting assembly

Wichtig – Bitte lesen Sie diese Anleitung vollständig durch, bevor Sie mit der Montage beginnen



Safety and Care Advice

Important – Please read these instructions fully before starting assembly

- Check you have all the components and tools listed on the following pages.
- Remove all fittings from the plastic bags and separate them into their groups.
- Keep children and animals away from the work area, small parts could choke if swallowed.
- Make sure you have enough space to layout the parts before starting.

- During assembly do not stand or put weight on the product, this could cause damage.
- Assemble the item as close to its final position (in the same room) as possible.
- Assemble on a soft level surface to avoid damaging the unit or your floor.
- Parts of the assembly will be easier with 2 people.



- To reduce the likelihood of damaging your product please ensure that your power drill is set on a low torque setting.

Care and maintenance

- Only clean using a damp cloth and mild detergent, do not use bleach or abrasive cleaners.
- From time to time check that there are no loose screws on this unit.
- This product should not be discarded with household waste. Take to your local authority waste disposal centre.

Handy Hints

- Assemble all parts and bolts loosely during assembly, only once the product is complete should you fully tighten the bolts
- Regularly check and ensure That all bolts and fittings are tightend properly.

WARNING In order to help prevent overturning – please follow these instructions

To help prevent product toppling over please follow the below steps:-

Use the anti tip stap or wall fixing method provided (if applicable)
Do not allow children to climb or hang on the furniture
Do not open more than one drawer at a time
Do not place heavy items in the top drawers
Do not place heavy items on top of the furniture, unless the furniture has been designed for this purpose

please note that only the anti tip strap is provided.

You will need to provide wall plugs and screws applicable for your wall type



Sicherheits- und Pflegehinweise

Wichtig – Bitte lesen Sie diese Anleitung vollständig durch, bevor Sie mit der Montage beginne

- Prüfen Sie, ob alle auf den folgenden Seiten aufgeführten Komponenten und Werkzeuge vorhanden sind.

- Entfernen Sie alle Beschläge aus den Plastiktüten und trennen Sie sie in ihre Gruppen.

- Kinder und Tiere vom Arbeitsbereich fernhalten, Kleinteile können beim Verschlucken ersticken

- Stellen Sie sicher, dass Sie genügend Platz haben, um die Teile anzuordnen, bevor Sie beginnen.

Stellen Sie sich während der Montage nicht auf das Produkt und belasten Sie es nicht, da dies zu Schäden führen kann.

- Montieren Sie den Artikel so nah wie möglich an seiner endgültigen Position (im selben Raum).

- Montieren Sie es auf einer weichen, ebenen Oberfläche, um eine Beschädigung des Geräts oder Ihres Bodens zu vermeiden.

- Teile der Montage werden mit 2 Personen einfacher sein.



- Um die Wahrscheinlichkeit einer Beschädigung Ihres Produkts zu verringern, stellen Sie bitte sicher, dass Ihre Bohrmaschine auf ein niedriges Drehmoment eingestellt ist.

Pflege und Wartung

- Nur mit einem feuchten Tuch und mildem Reinigungsmittel reinigen, keine Bleich- oder Scheuermittel verwenden.

- Überprüfen Sie von Zeit zu Zeit, dass keine Schrauben an diesem Gerät locker sind.

- Dieses Produkt darf nicht mit dem Hausmüll entsorgt werden. Bringen Sie es zu Ihrem örtlichen Entsorgungszentrum.

Praktische Tipps

- Montieren Sie bei der Montage alle Teile und Schrauben lose, erst wenn das Produkt komplett ist, sollten Sie die Schrauben fest anziehen

- Überprüfen Sie regelmäßig und stellen Sie sicher, dass alle Schrauben und Beschläge ordnungsgemäß angezogen sind.

WARNUNG

Um ein Umkippen zu verhindern – Bitte befolgen Sie diese Anweisungen

Um ein Umkippen des Produkts zu verhindern, befolgen Sie bitte die folgenden Schritte:

Verwenden Sie den Kippschutz oder die mitgelieferte Wandbefestigungsmethode (falls zutreffend). Lassen Sie Kinder nicht auf die Möbel klettern oder sich daran hängen. Öffnen Sie nicht mehr als eine Schublade gleichzeitig. Legen Sie keine schweren Gegenstände in die oberen Schubladen. Stellen Sie keine schweren Gegenstände auf die Möbel, es sei denn, die Möbel sind für diesen Zweck konzipiert.

Bitte beachten Sie, dass nur der Kippschutzgurt mitgeliefert wird. Sie müssen für Ihren Wandtyp geeignete Dübel und Schrauben bereitstellen.











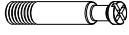



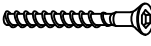

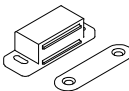

Components - Fittings / Komponenten - Beschläge

Please check you have all the panels listed below

Bitte überprüfen Sie, ob Sie alle unten aufgeführten Panels haben

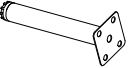
Note: The quantitie below are the correcet amount to complete the assembly. In some cases more fittings may be supplied than are required.

Notiz: Die folgenden Mengen sind die richtige Menge, um die Montage abzuschließen. In manchen Fällen werden mehr Fittings geliefert als benötigt werden.

A  Male Camlock x 14	B  Female Camlock x 14	C  Dowel x 18
D  3.5*14mm Screw x 40	E  6*50mm Screw x 6	F  Hex Key M4 x 1
G  4*14mm Screw x 4	H  Handle x 4	I  3*16mm Screw x 16
J  Magnet Touch x 4	K  Plastic pivot x 8	L  Door Hinge x 4
M  Door Hinge x 4	N  Plastic wedge x 8	O  Legs x 4
P  Middle Leg x 1	Q  6*12mm Screw x 8	R  3*12mm Screw x 8
S  Wall Fixing Pack x 2	T  Ø20 Sticker x 6	

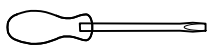

Tools required / Werkzeuge benötigt

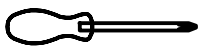

Phillips screwdriver (medium & large) Kreuzschlitzschraubendreher (mittel und groß)

Ruler - Use this ruler to help correctly identify the screws

Lineal - Verwenden Sie dieses Lineal, um die Schrauben richtig zu identifizieren



The screws length is measured from the head to the point (30mm screw shown).
Die Schraubenlänge wird vom Kopf bis zur Spitze gemessen (30-mm-Schraube abgebildet).

Using Camlocks

Step 1

Connect the male camlock as directed in the assembly instructions using a screwdriver.

1

DO NOT OVER TIGHTEN.
NE PAS SERRER EXCESSIVEMENT.

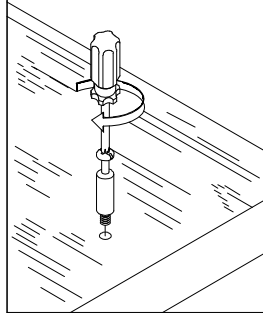

Step 2

Push the male camlock into the entry hole.

2

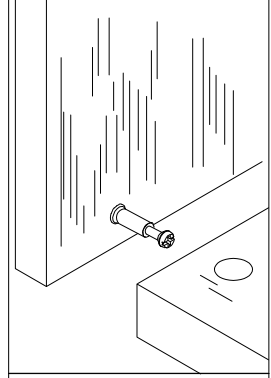

Step 3

Insert the female camlock as shown in the instruction.

Note: ensure that the arrow on the top of the camlock points towards the entry hole for the male camlock.

3

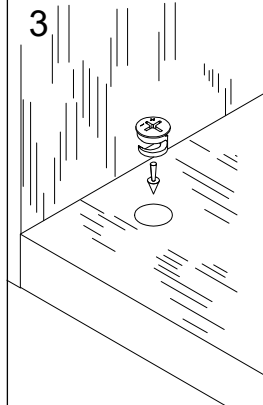

Step 4

Turn the female camlock clockwise with a screwdriver.

You should feel a click when the camlock is locked in place.

The joint is now secure.

4

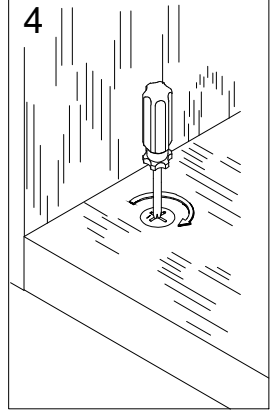

Verwendung von Camlocks

Schritt 1

Schließen Sie das männliche Camlock gemäß den Anweisungen in der Montageanleitung mit einem Schraubendreher an.

1

DO NOT OVER TIGHTEN.
NE PAS SERRER EXCESSIVEMENT.

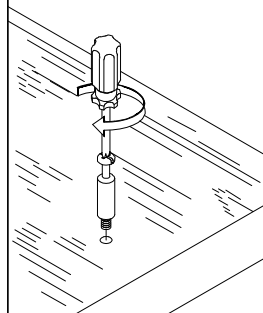

Schritt 2

Schieben Sie das Männlicher Camlock in das Eingangslot.

2

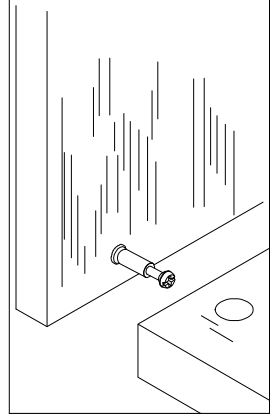

Schritt 3

Setzen Sie das Femalecamlock wie in der Anleitung gezeigt ein.

Hinweis: Stellen Sie sicher, dass der Pfeil auf der Oberseite des Camlocks auf das Eintrittsloch für den männlichen Camlock zeigt.

3

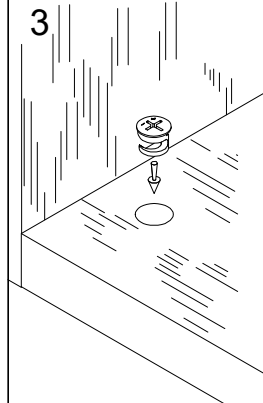

Schritt 4

Drehen Sie die Weibliches Camlock mit einem Schraubendreher im Uhrzeigersinn.

Sie sollten ein Klicken spüren, wenn der Camlock eingerastet ist.

Das Gelenk ist jetzt sicher

4

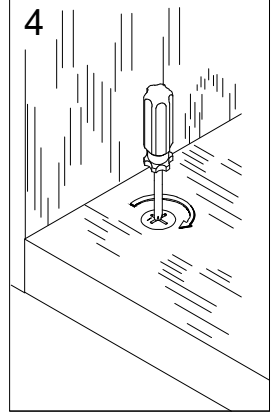

Assembly Instructions / Montageanleitungen

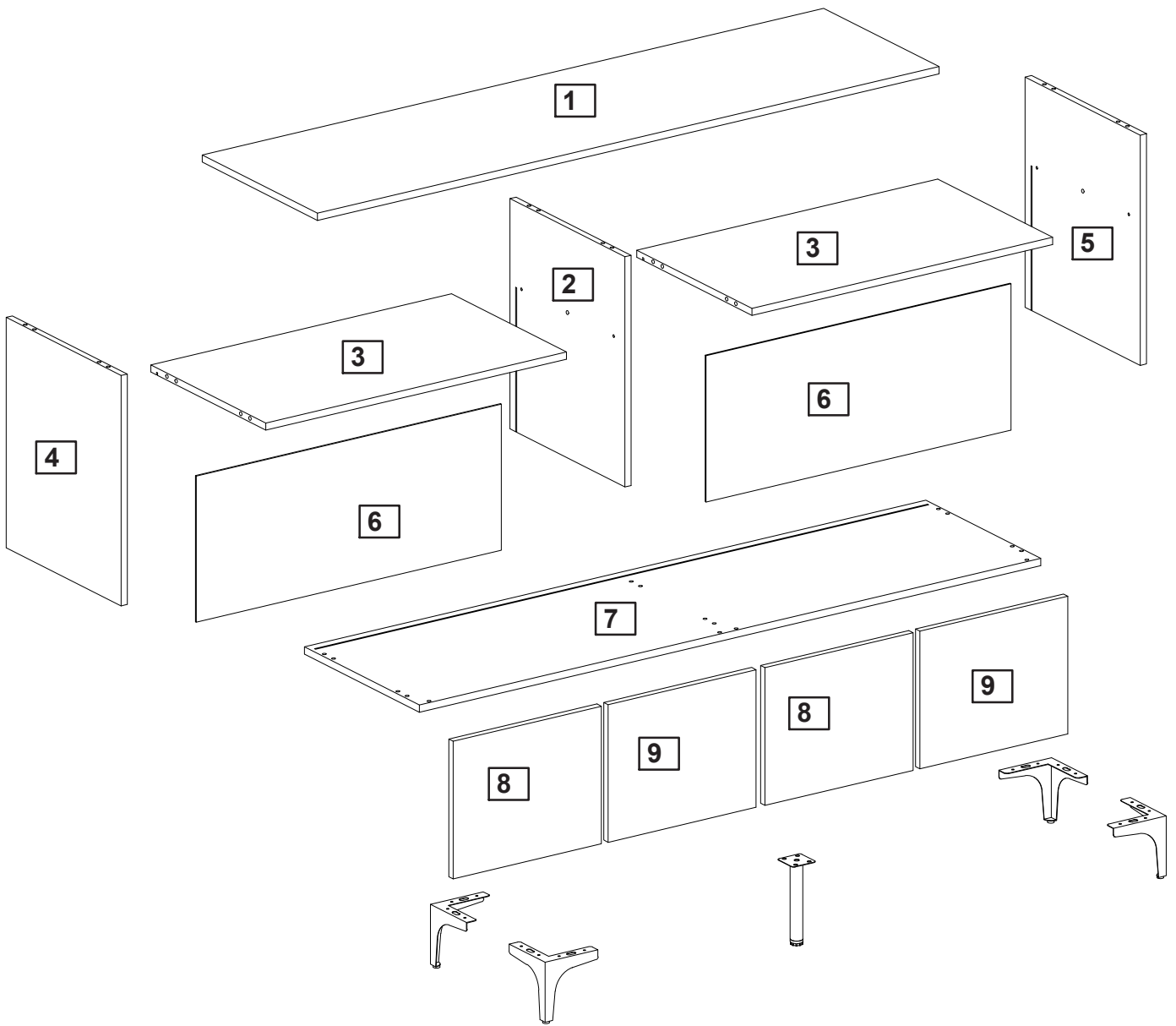

Part List / Komponenten - Paneele

WF307277

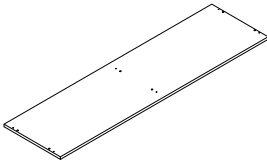
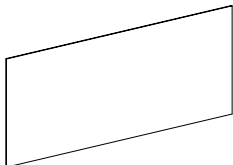
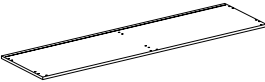
<p>①</p>  <p>1 PC</p>	<p>⑥</p>  <p>2 PCS</p>	<p>⑦</p>  <p>1 PC</p>
---	---	--

Part List / Komponenten - Paneele

WF307278

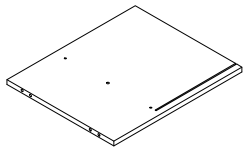
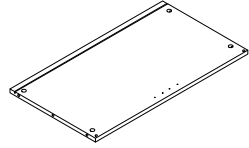
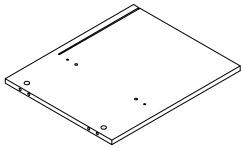
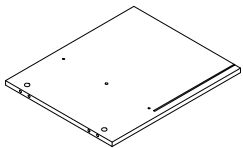
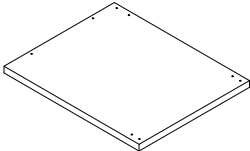
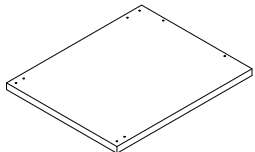
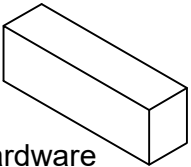
<p>②</p>  <p>1 PC</p>	<p>③</p>  <p>2 PCS</p>	<p>④</p>  <p>1 PC</p>	<p>⑤</p>  <p>1 PC</p>	<p>⑧</p>  <p>2 PCS</p>
<p>⑨</p>  <p>2 PCS</p>	 <p>Hardware die fünf Metalle 1 PC</p>			

Assembly Instructions / Montageanleitungen

Step 1

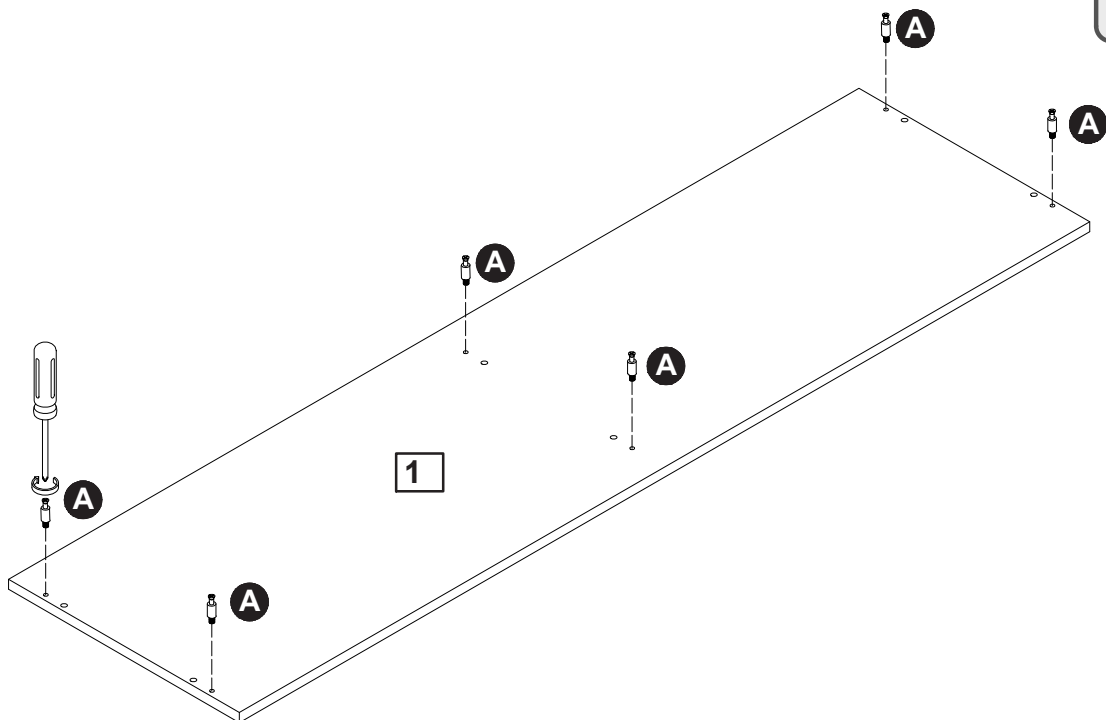

Step 2

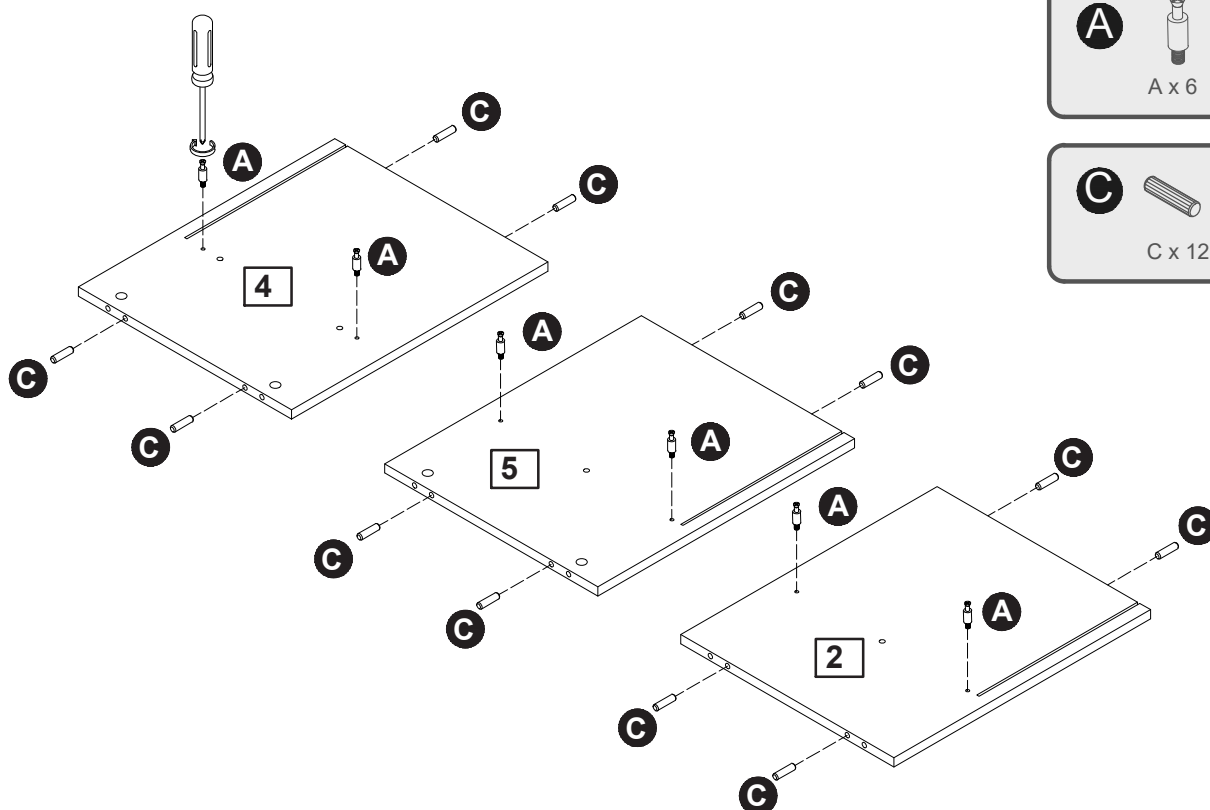

Assembly Instructions / Montageanleitungen

Step 3

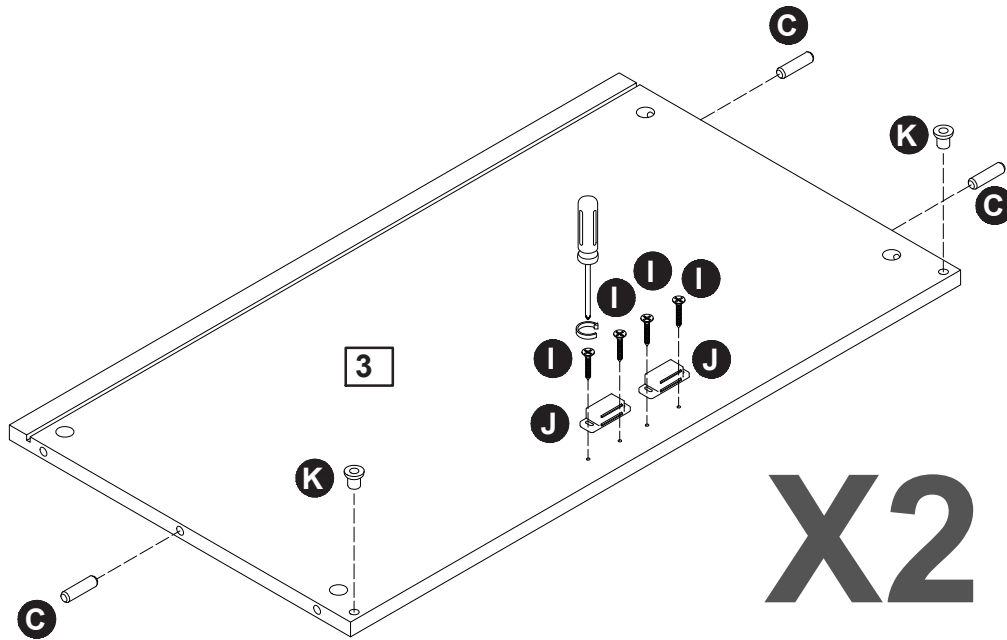

C 
C x 6

I 
I x 8

J 
J x 4

K 
K x 4

Place K into holes

Step 4

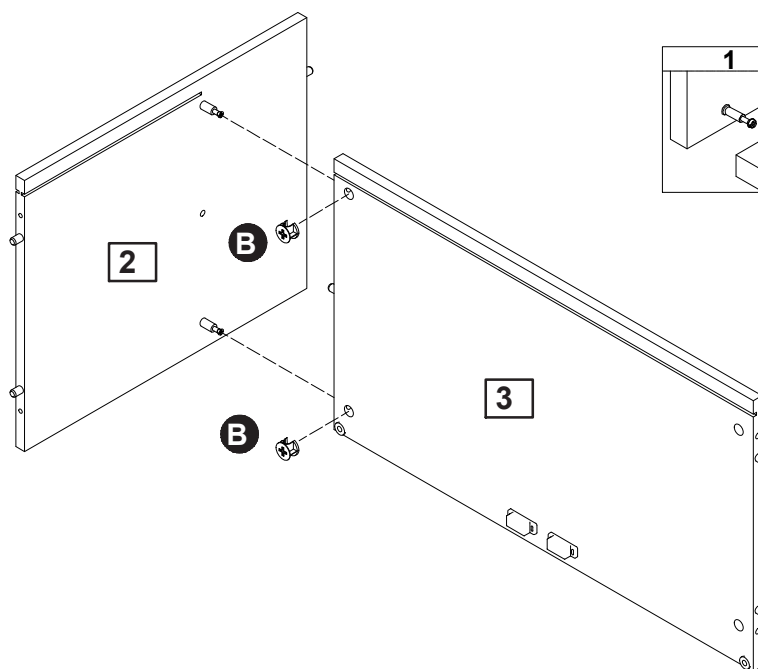

B 
B x 2

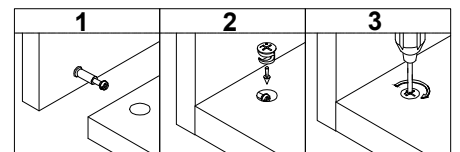

Assembly Instructions / Montageanleitungen

Step 5

B



B x 2

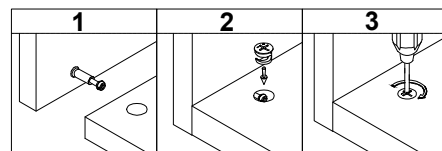
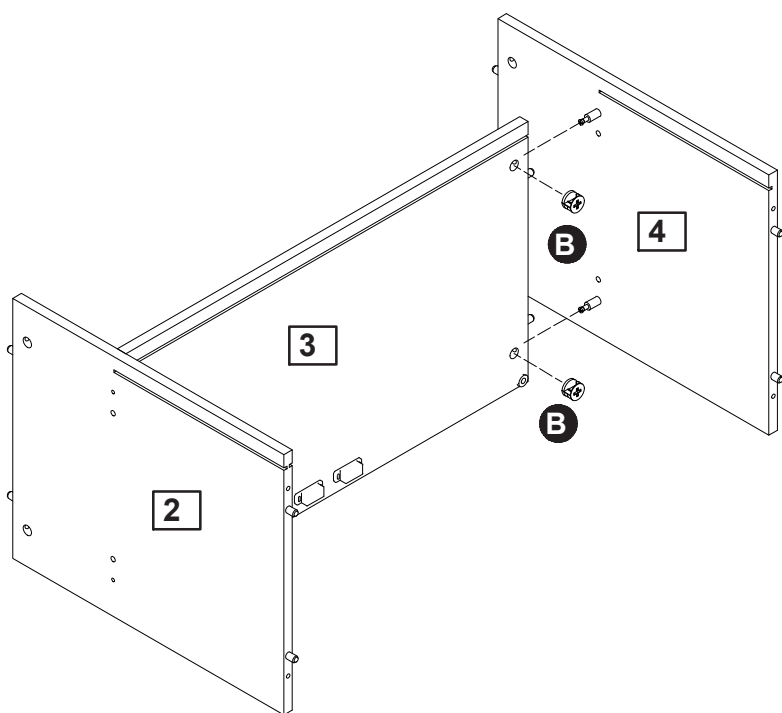

Step 6

A



A x 2

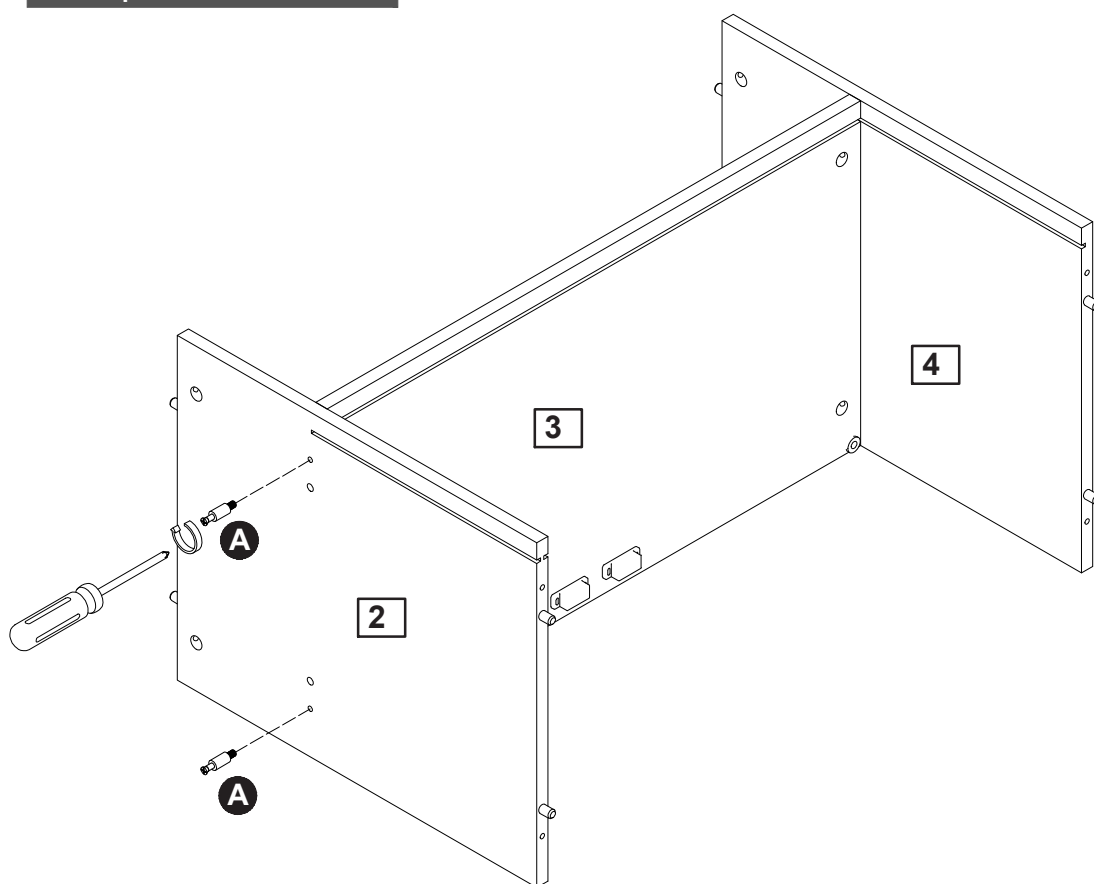

Assembly Instructions / Montageanleitungen

Step 7

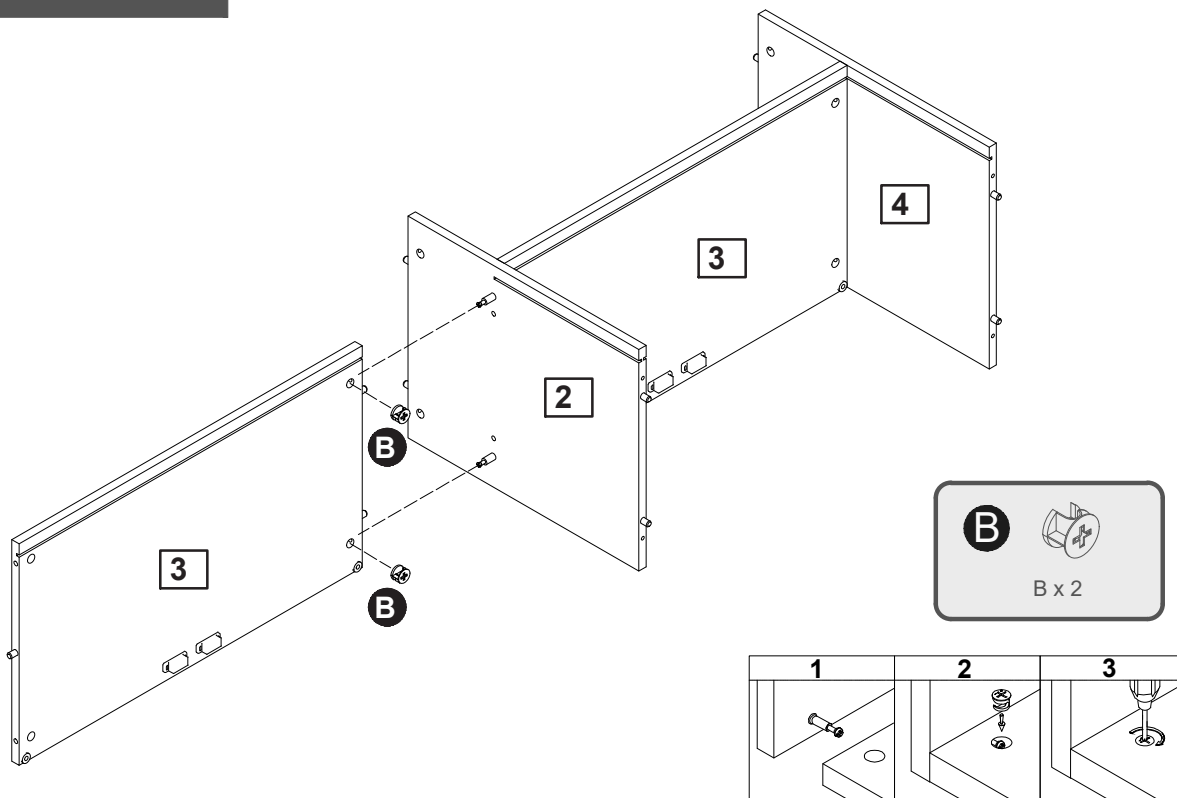

Step 8

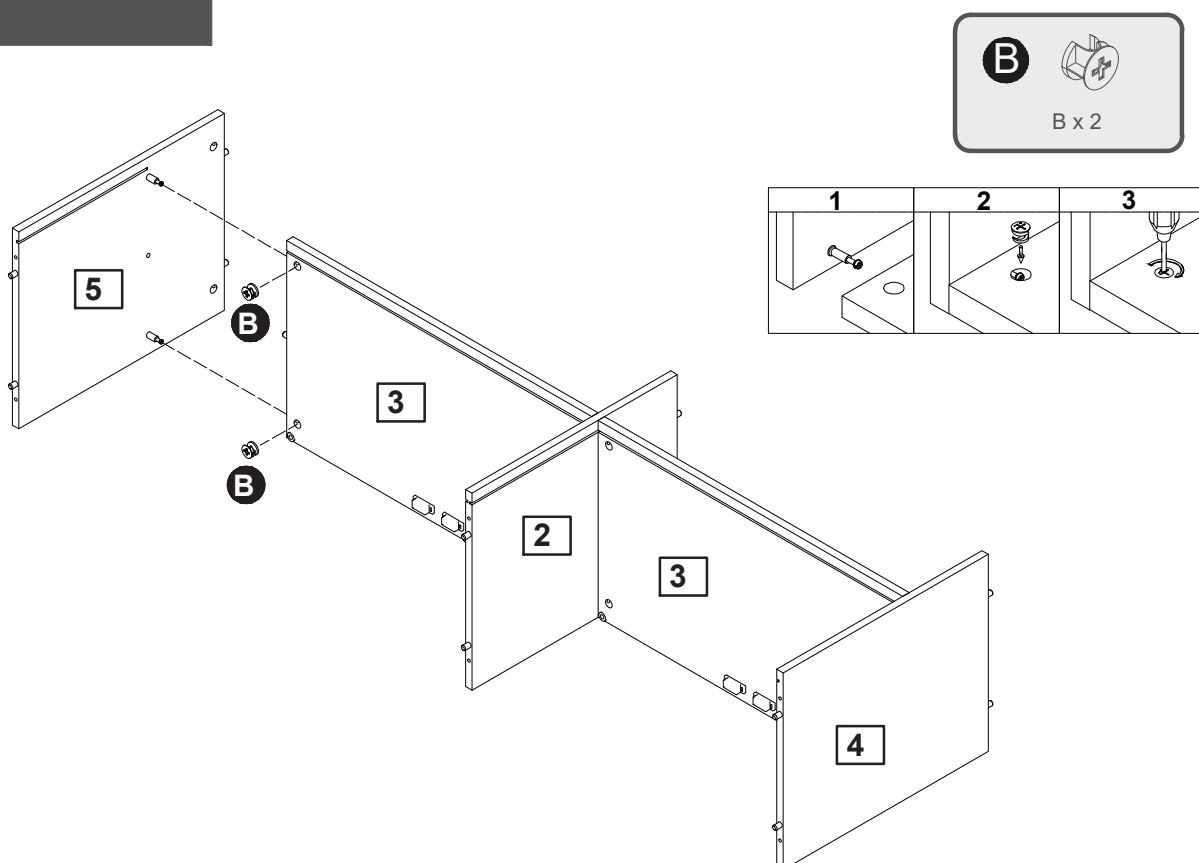

Assembly Instructions / Montageanleitungen

Step 9

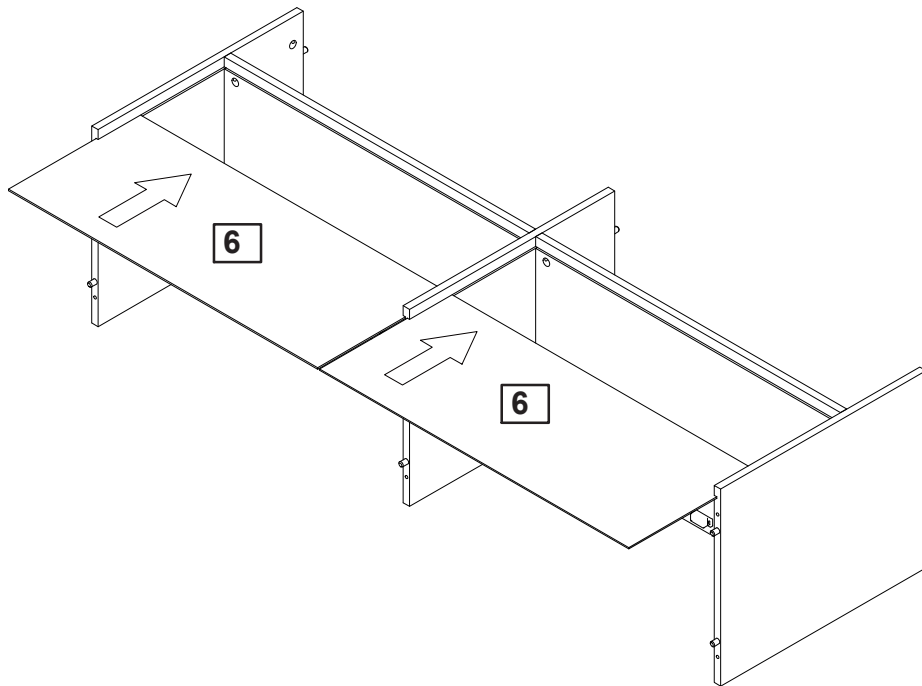

Step 10

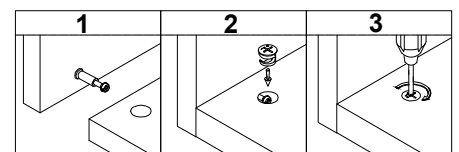
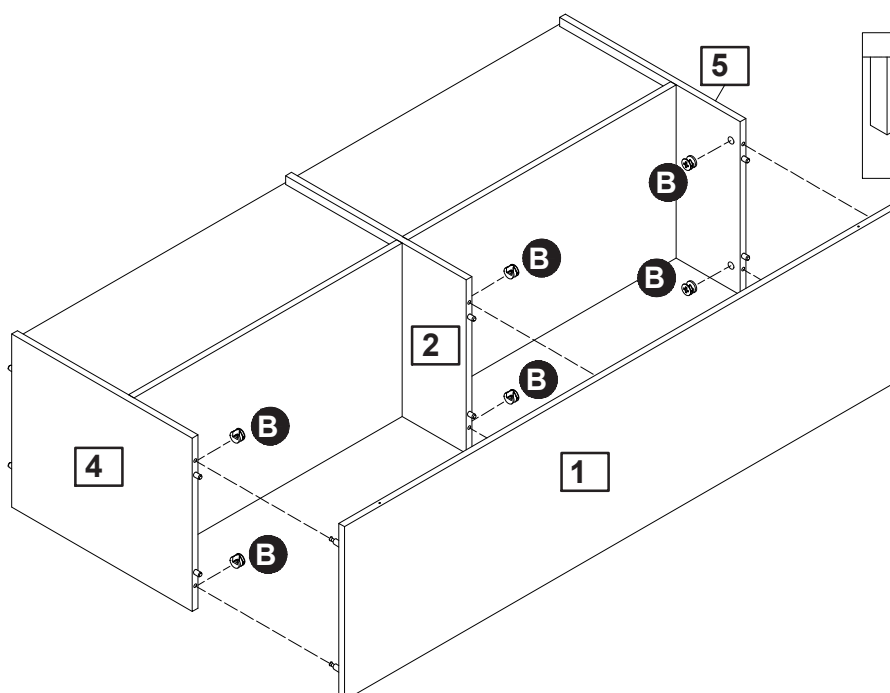
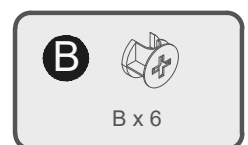

Assembly Instructions / Montageanleitungen

Step 11

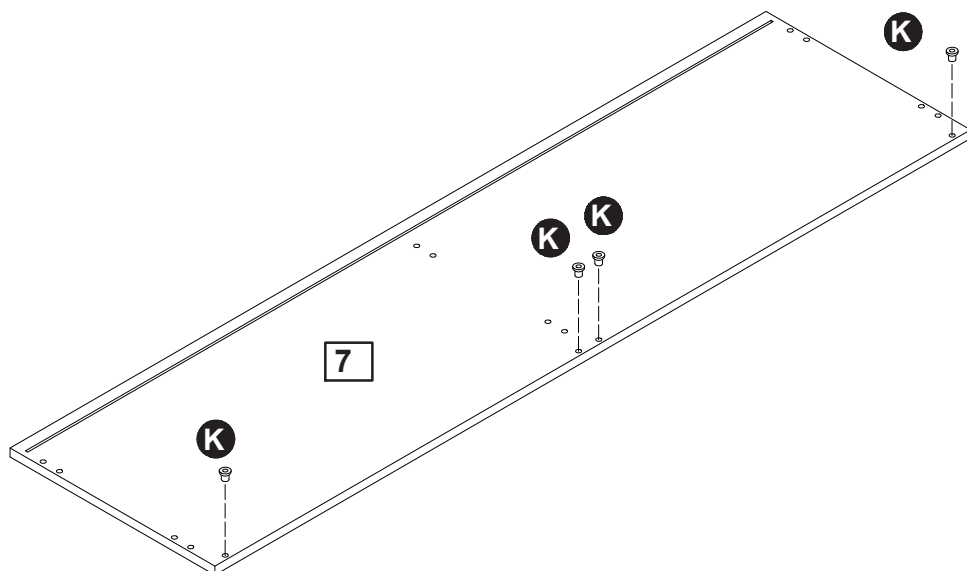

Place K into holes
Steck K in die öfFnung

Step 12

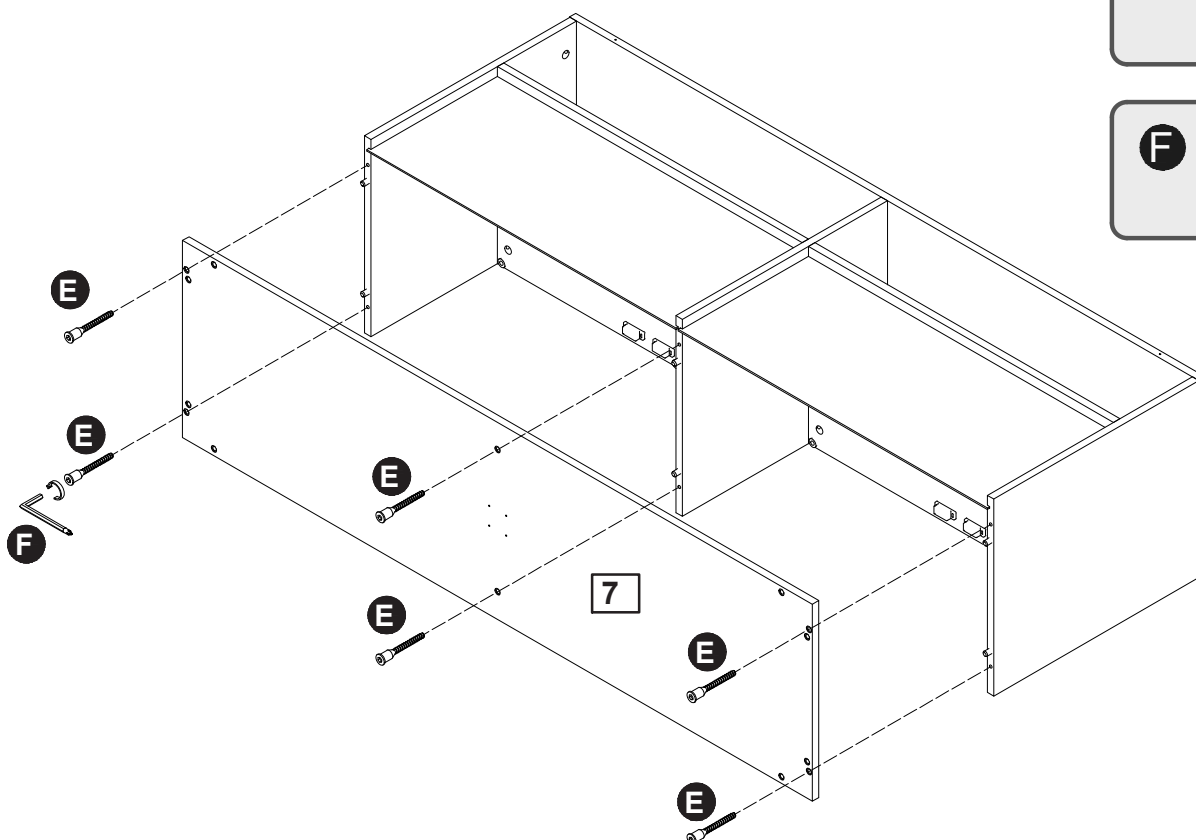

Assembly Instructions / Montageanleitungen

Step 13

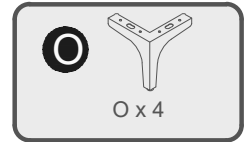
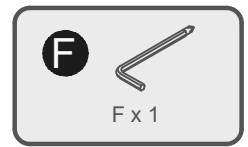
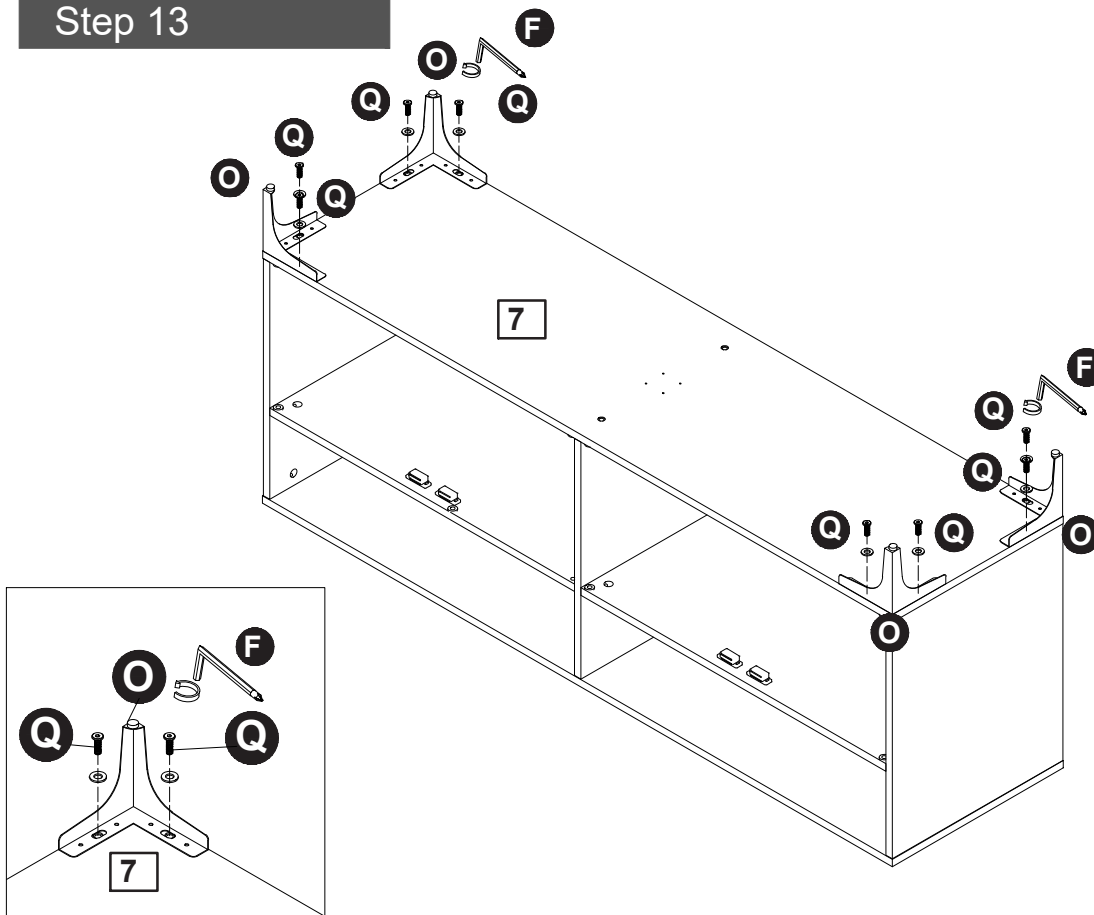

Step 14

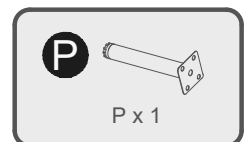
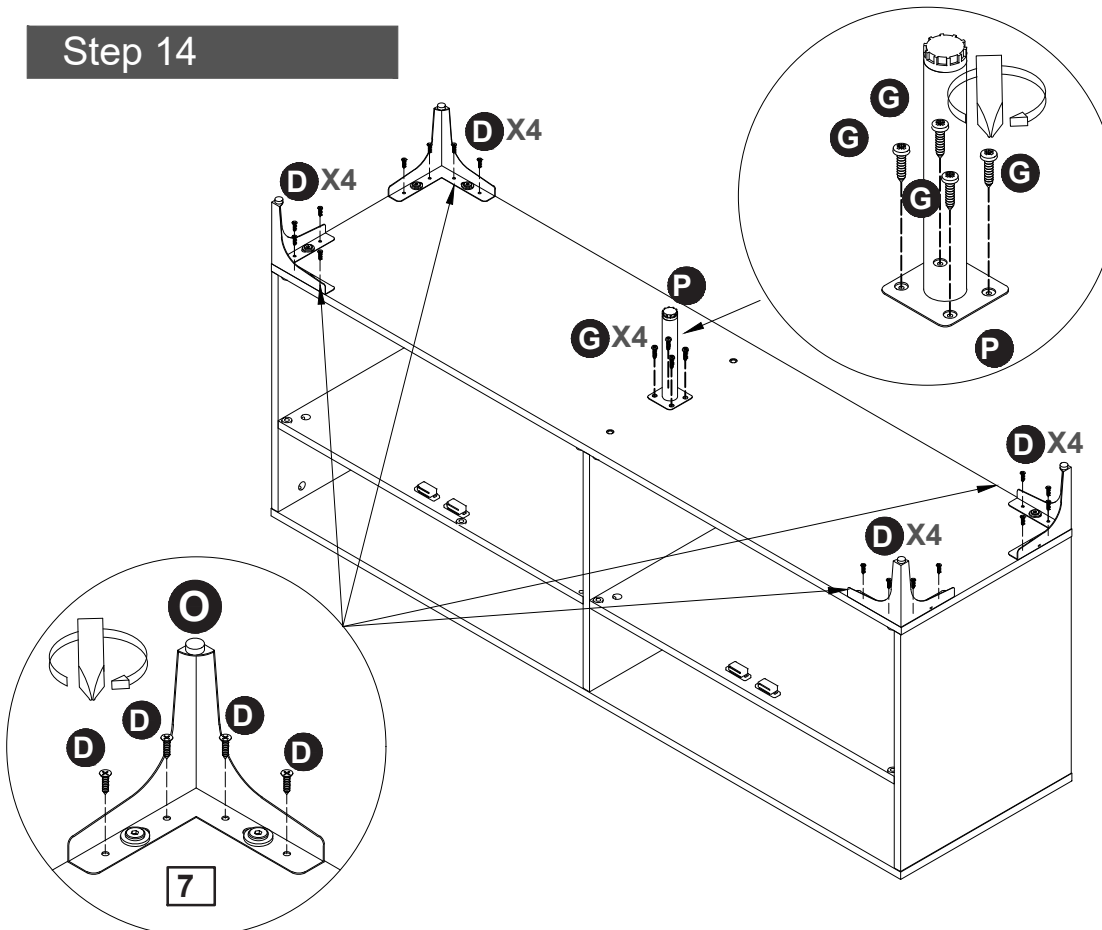

Assembly Instructions / Montageanleitungen

Step 15

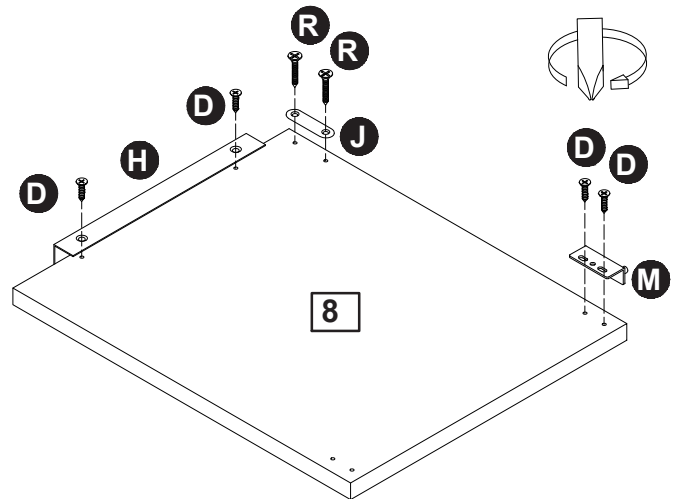
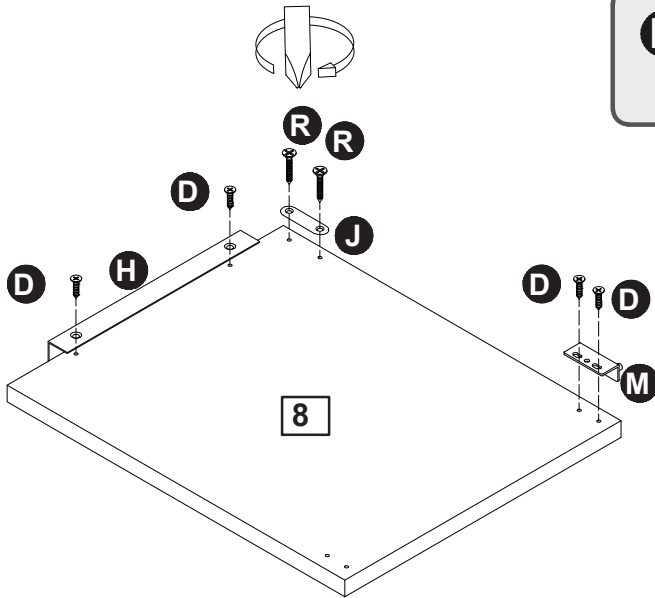
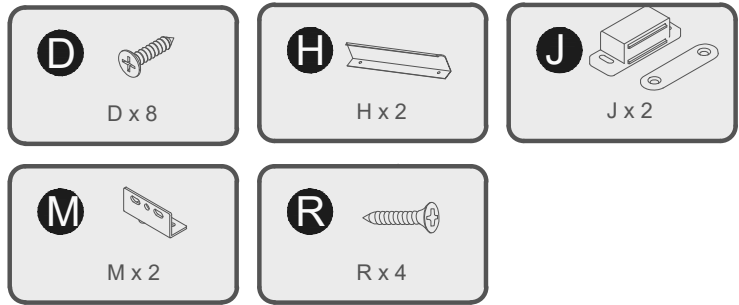

Step 16

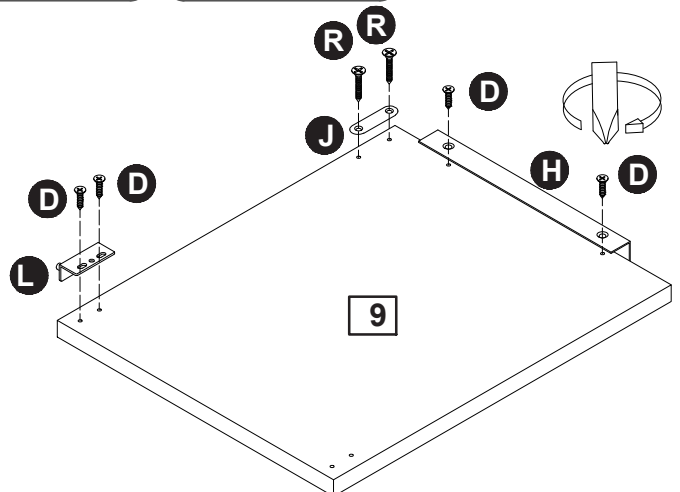
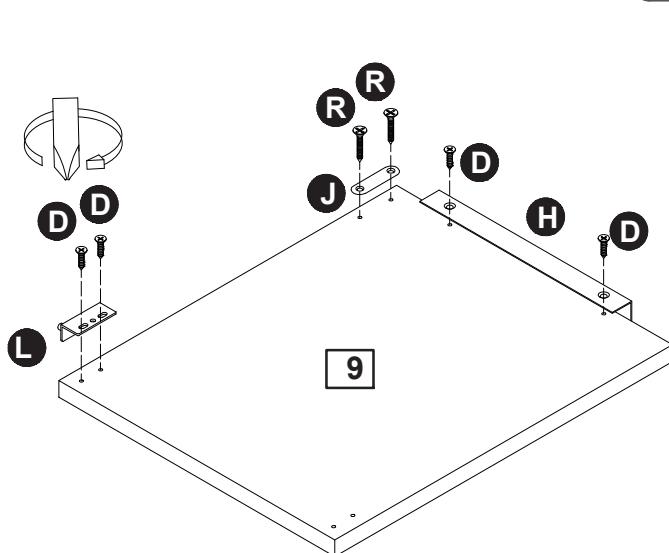
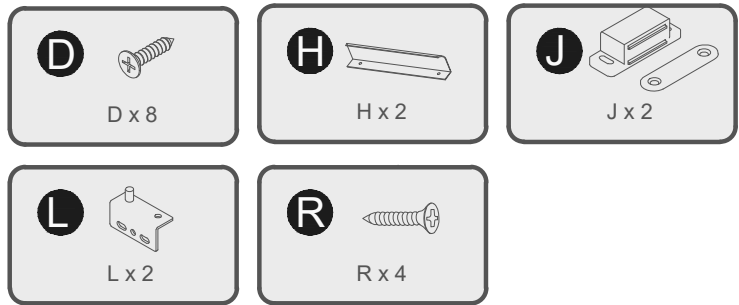

Assembly Instructions / Montageanleitungen

Step 17

Türangel (L) in plastikklauen (K) auf. Türangel (M) in kunststoff einfügen
 In einem schraubenschlüssel (3) werden die angeln in den angeln geschraubt (8). Verriegelt das tor.
 Die scharniere (L) und der bolzen (D) unter gleichstarker belastung.

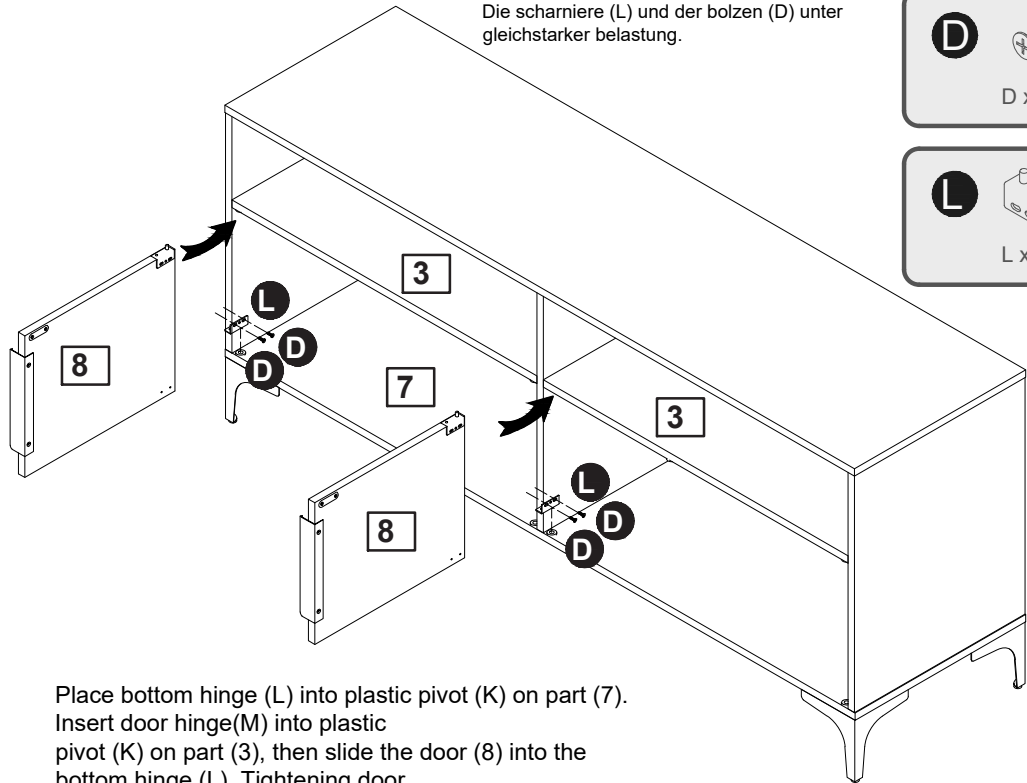
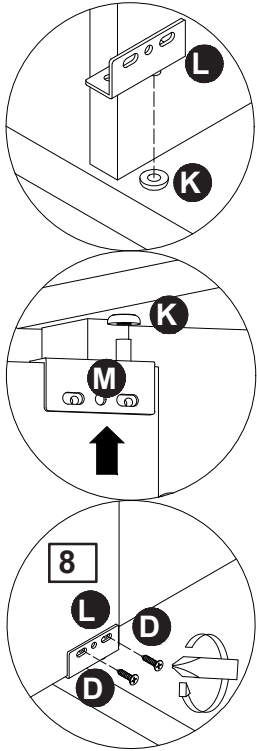

Place bottom hinge (L) into plastic pivot (K) on part (7).
 Insert door hinge (M) into plastic pivot (K) on part (3), then slide the door (8) into the bottom hinge (L). Tightening door hinge (L) with screws (D) in equal pressure.

Step 18

Place bottom hinge (M) into plastic pivot (K) on part (7).
 Insert door hinge (L) into plastic pivot (K) on part (3), then slide the door (9) into the bottom hinge (M). Tightening door hinge (M) with screws (D) in equal pressure.

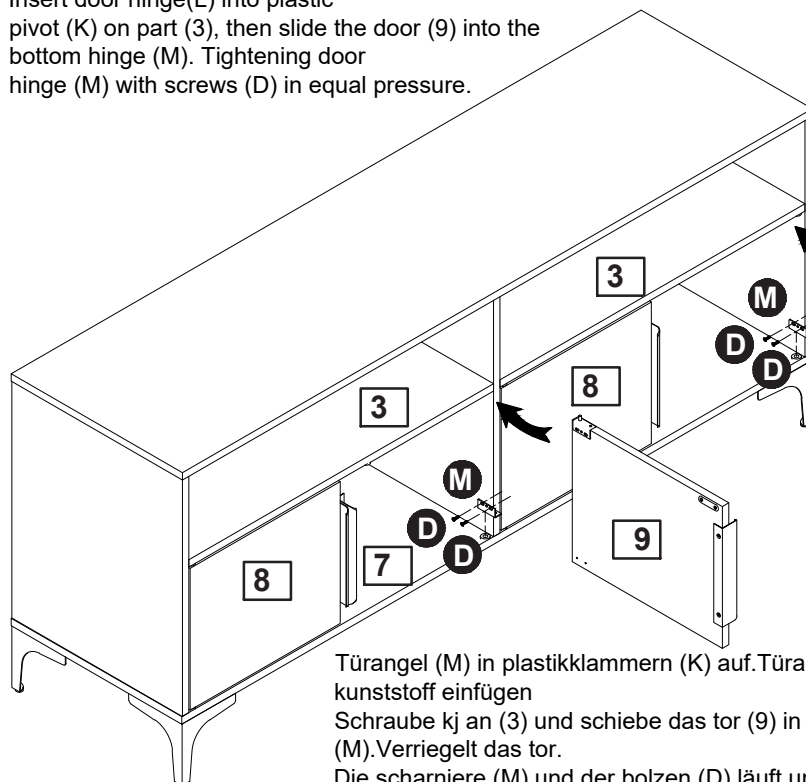
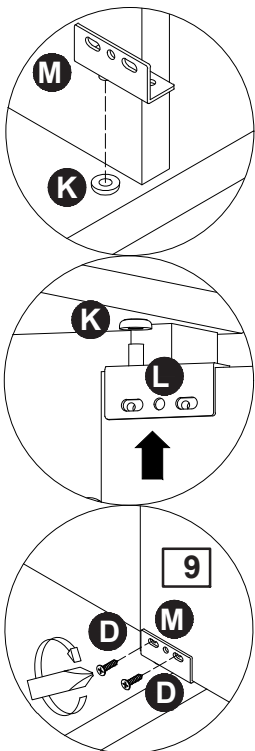

Türangel (M) in plastikklammern (K) auf. Türangel (L) in kunststoff einfügen
 Schraube (D) an (3) und schiebe das tor (9) in die angeln (M). Verriegelt das tor.
 Die scharniere (M) und der bolzen (D) läuft unter großem druck.

Assembly Instructions / Montageanleitungen

Step 19

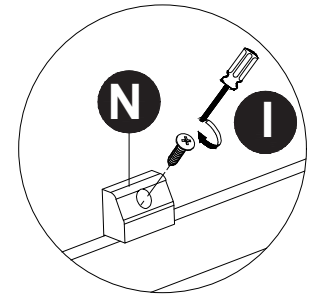
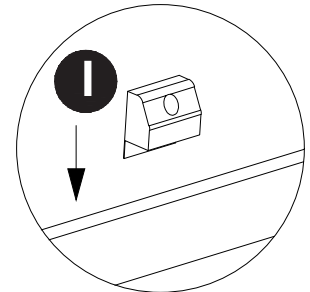
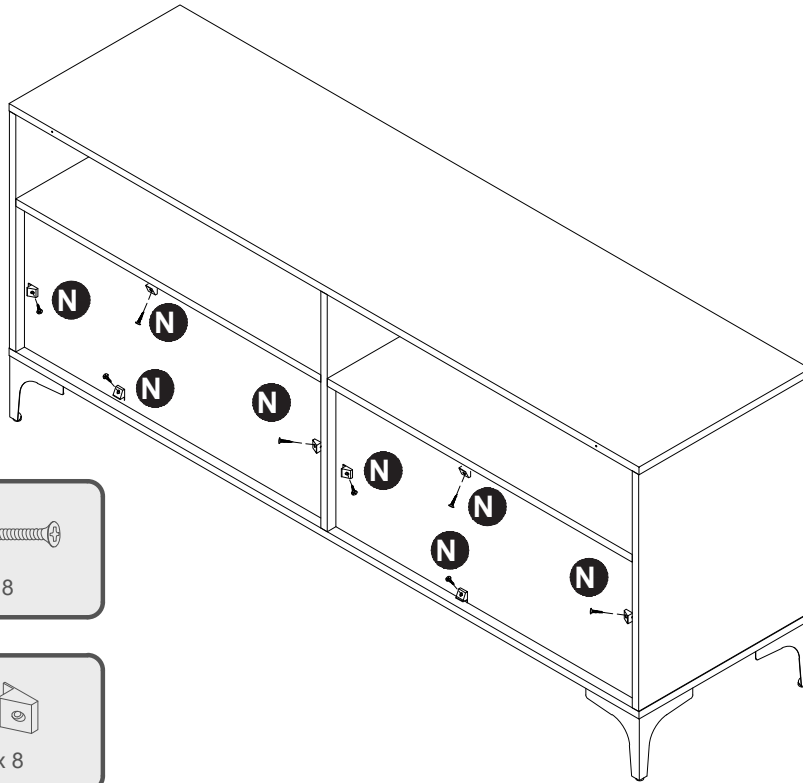

Step 20

In die krallen
Steh auf, aber es ist Hey,
großvater Die kriege.
1. nd bringt die ausrüstung
an bord Wollt ihr in
position?
2. Male die wände an
Der rechte abschreiber
Der sitz steht fest.
Löcher.



Das eingehende signal
Ohne eis geht's rund
Rohre ausblenden!
Und den kabeln.

3. Bohrer bohren und stoßen mit
2x Einen wandbioport.
4. Nimm zwei steinbänder
Sie können am ende der einheit
2 x verwenden Dichtungsring
und zwei bolzen
5. Du hältst den band fest
2 dichtungsringe für die wand
Und zwei bolzen
Du versteckst die kassetten
immer Sie sind hinter der einheit,
black
Die löcher bleiben unter dem
dach.
Einheit.

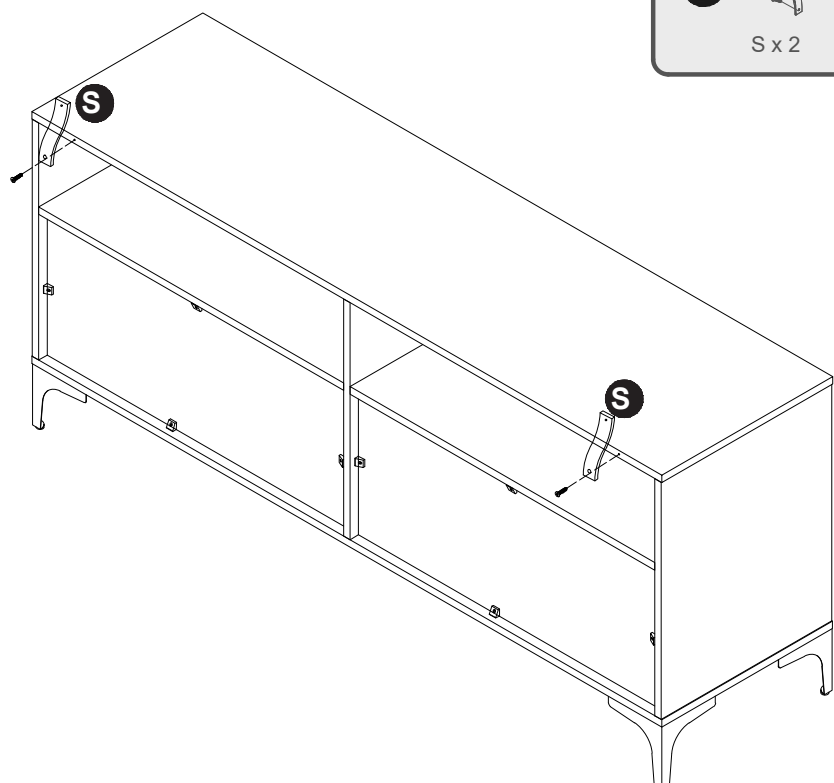
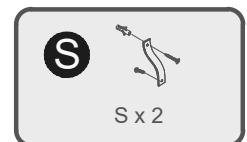

Assembly Instructions / Montageanleitungen

Step 21

In die krallen
Steh auf, aber es ist Hey,
großvater Die kriege.
1. nd bringt die ausrüstung
an bord Wollt ihr in
position?
2. Male die wände an
Der rechte abschreiber
Der sitz steht fest.
Löcher.



Das eingehende signal
Ohne eis geht's rund
Rohre ausblenden!
Und den kabeln.

3. Bohrer bohren und stoßen mit
2x Einen wandbioport.
4. Nimm zwei steinbänder
Sie können am ende der einheit
2 x verwenden Dichtungsring
und zwei bolzen
5. Du hältst den band fest
2 dichtungsringe für die wand
Und zwei bolzen
Du versteckst die kassetten
immer Sie sind hinter der einheit,
black
Die löcher bleiben unter dem
dach.
Einheit.

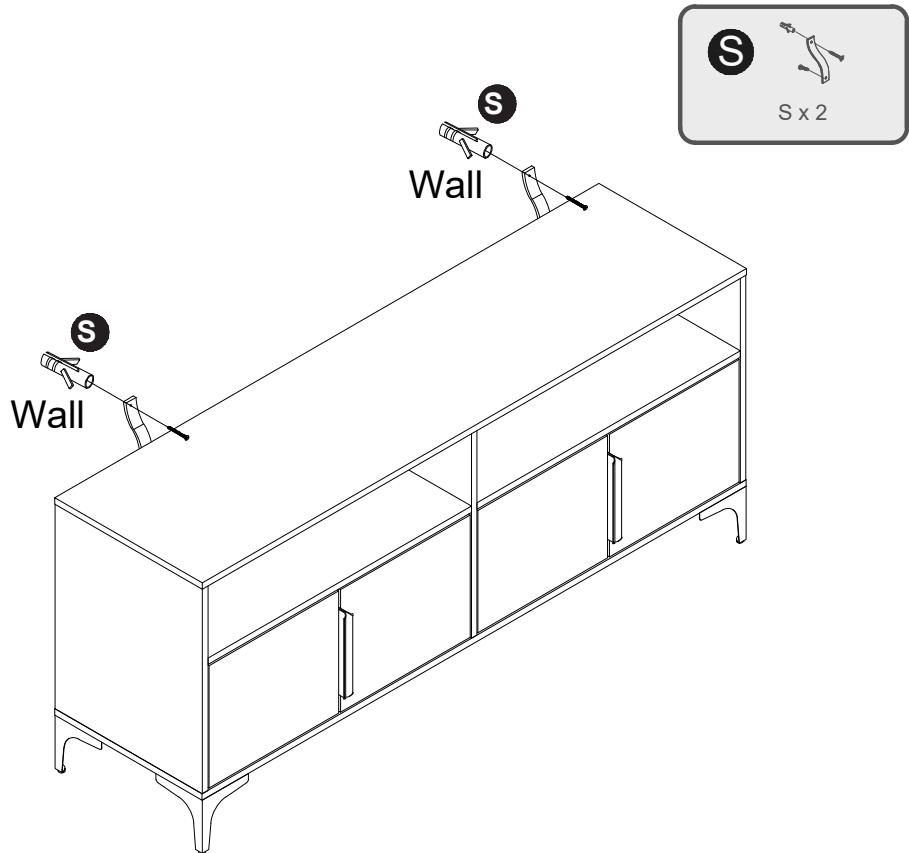

Step 22

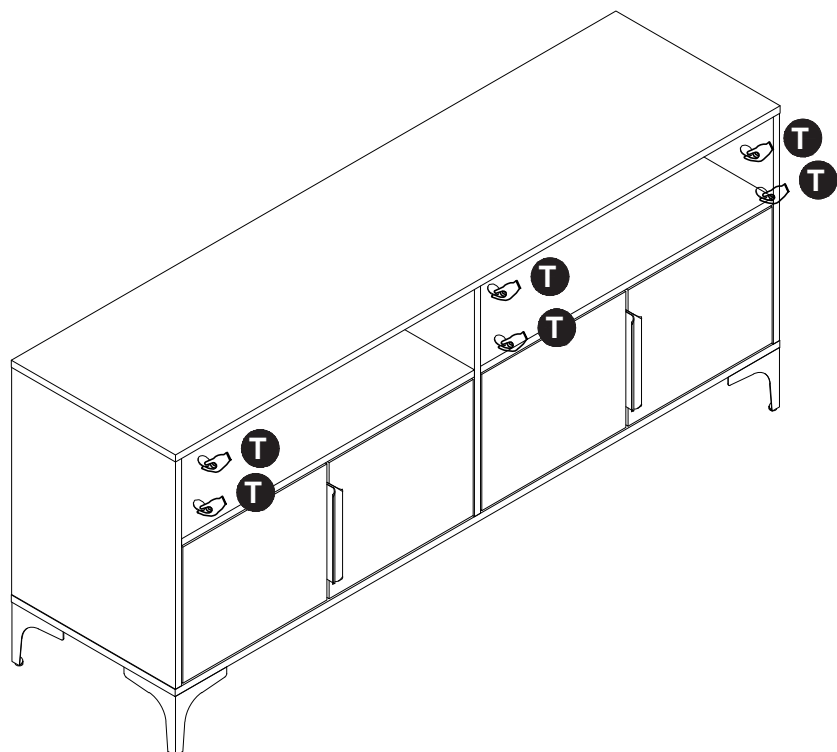
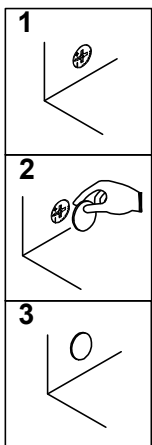
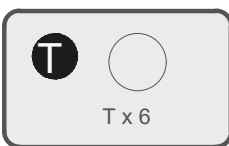

**Assembly is complete.
Die Montage ist abgeschlossen.**