

- | | |
|---|---|
| (D) Montageanleitung
956044/ 9560358 | (GB) Assembly instructions
956044/ 9560358 |
| (FR) Notice de montage
956044/ 9560358 | (IT) Istruzioni di montaggio
956044/ 9560358 |
| (NL) Handleiding voor de montage
956044/ 9560358 | (PL) Instrukcja montażu
956044/ 9560358 |
| (CZ) Montážní návod
956044/ 9560358 | (SK) Návod na montáž
956044/ 9560358 |
| (HU) Szerelési útmutató
956044/ 9560358 | (RO) Instrukțiuni de montaj
956044/ 9560358 |
| (TR) Montaj talimatı
956044/ 9560358 | (RU) Инструкция по монтажу
956044/ 9560358 |

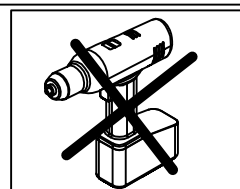
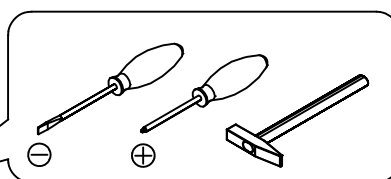
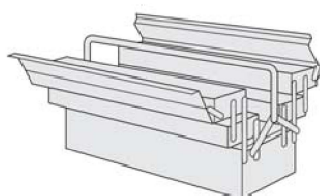
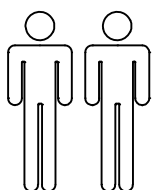

Name • Nom • Nome • Naam • Nazwa • Jméno •
Názov • Név • Denumire • İsim • Название

Nr. • No. • № • Номер • Č • Sz

Typ • Type • Tip • Típus • Tun

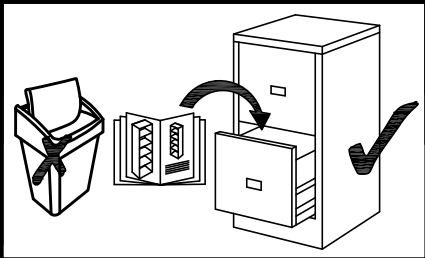
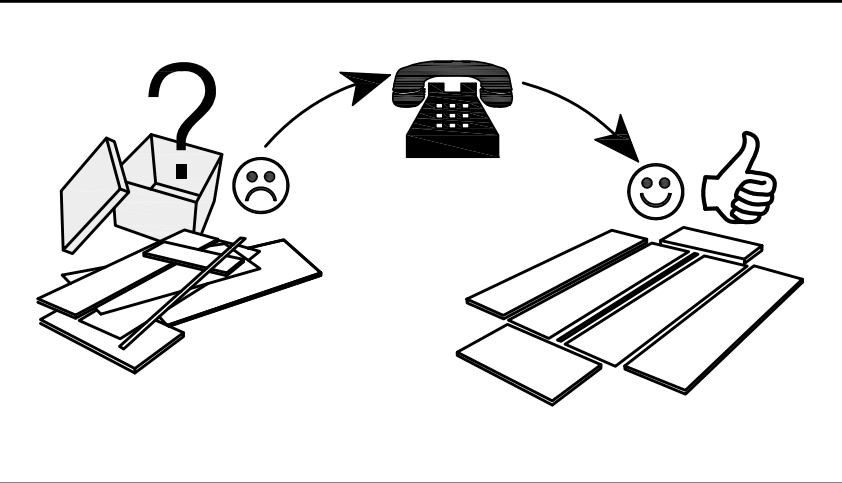

0
10
20
30
40
50
60
70
80
90
100
110
120
130
140
150
160
170
180
190
200

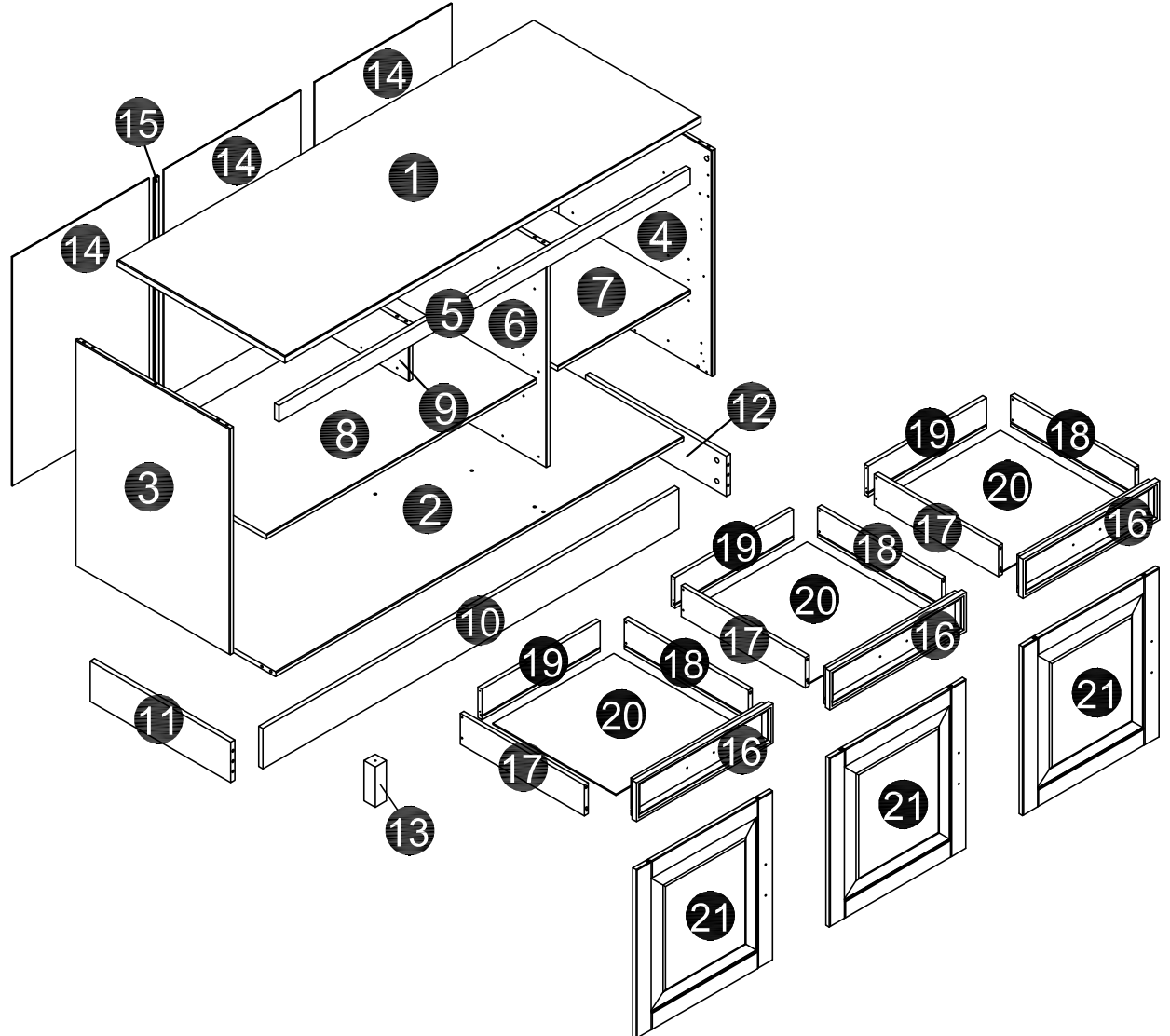

A Ø8x35mm 28x	B Ø6,5x34mm 22x	C Ø15x11mm 22x	D Ø3,5x15mm 6x	Ae Ø26mm 6x	E 6x	G Ø1,2x20mm 100x	H 1x	N Ø5x16mm 8x
Ag 3x	Ah 3x	L 6x	M Ø4x19mm 12x	P Ø7x50mm 4x	R 1x	K 20x20x16mm Ø6,5mm 14x	Ba Ø6,3x11mm 28x	Aa Ø5,8x8mm 18x
O Ø3,5x35mm 12x	I 20x16mm Ø4,5 1x	J Ø4x60mm 1x	U 1x	FL Klej CZ Leptilo SK Elaj HU Ernyv RO Adeziv TR Tukkaç RU Клей D Leim GB Glue FR Colle IT Colla NL Lijm				



Achtung • Attention • Opgelet • Uwaga • Dikkat • Внимание

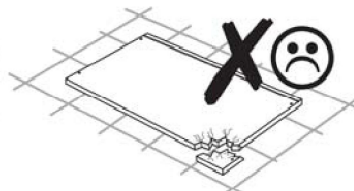
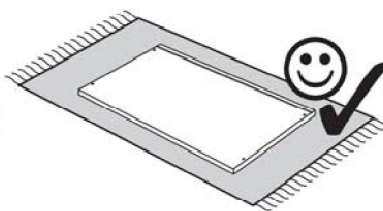

1

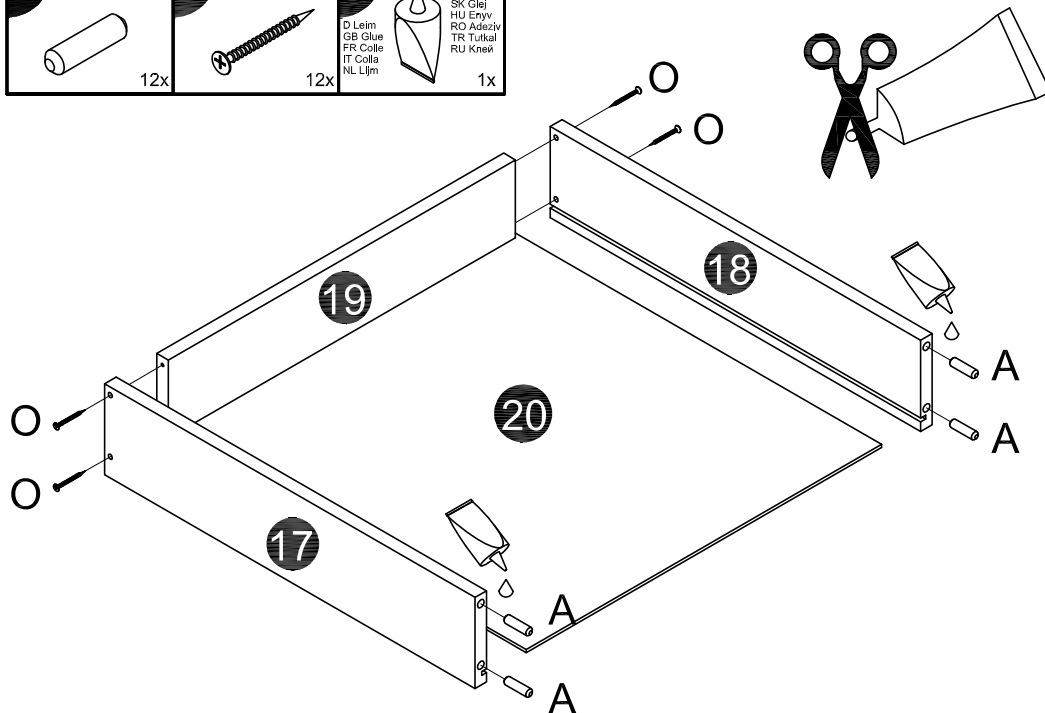
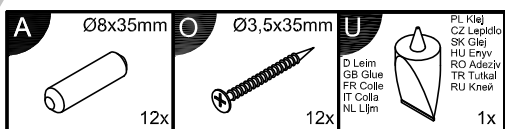

x3

2

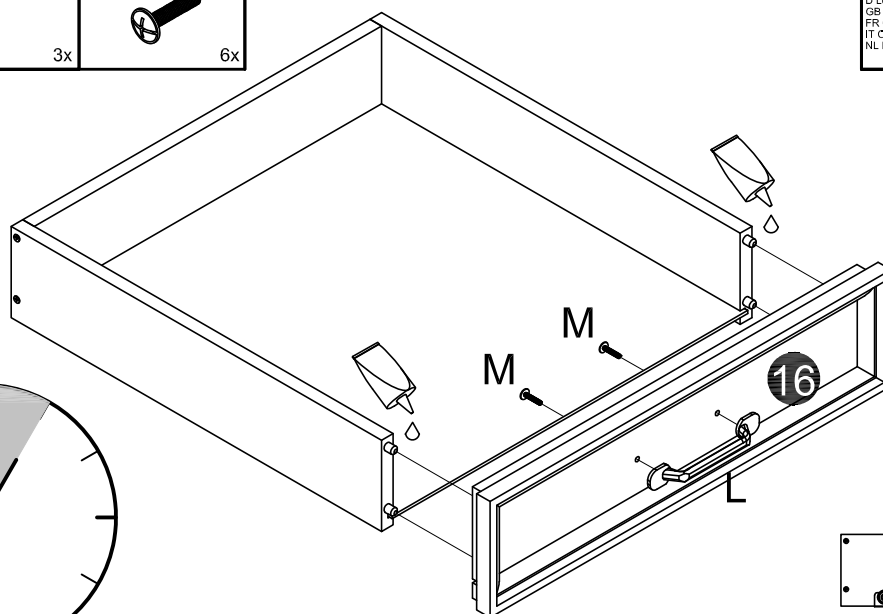
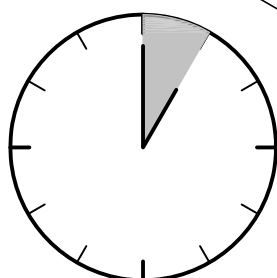
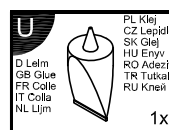
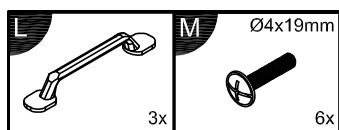

x3 !

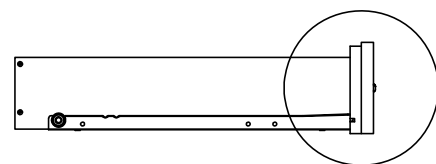

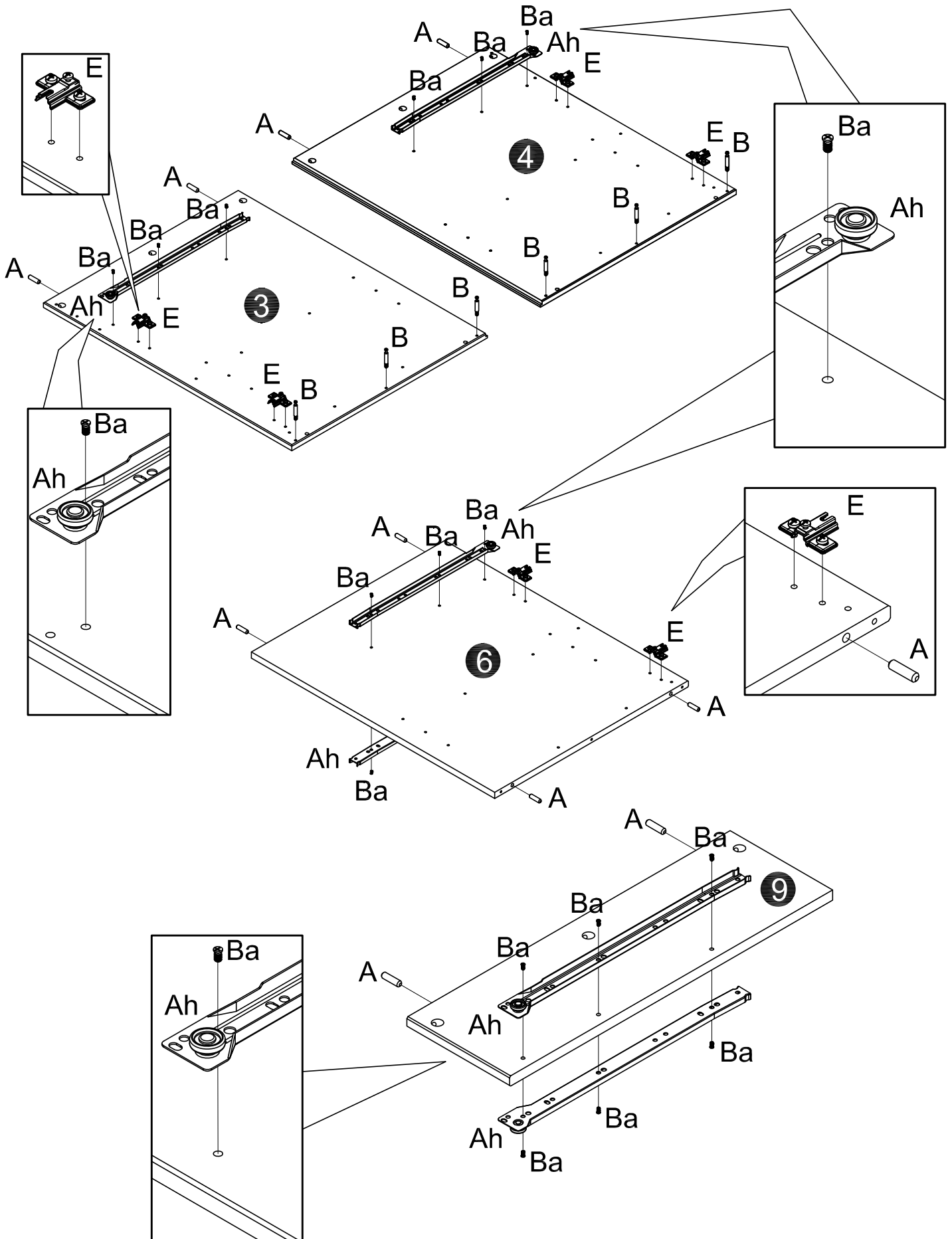
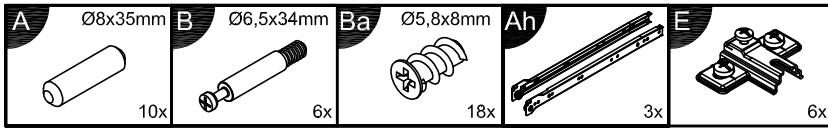

4

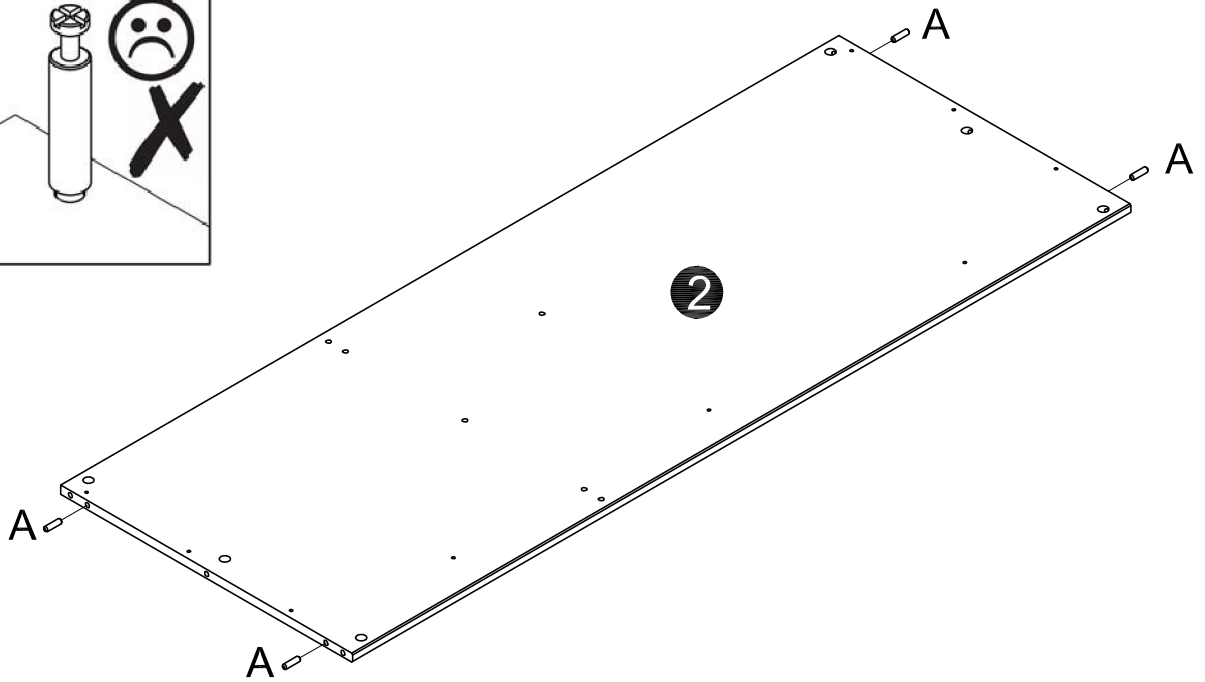
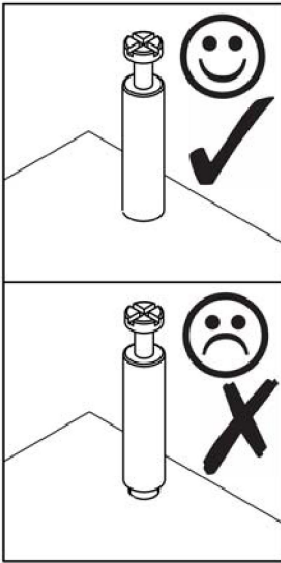
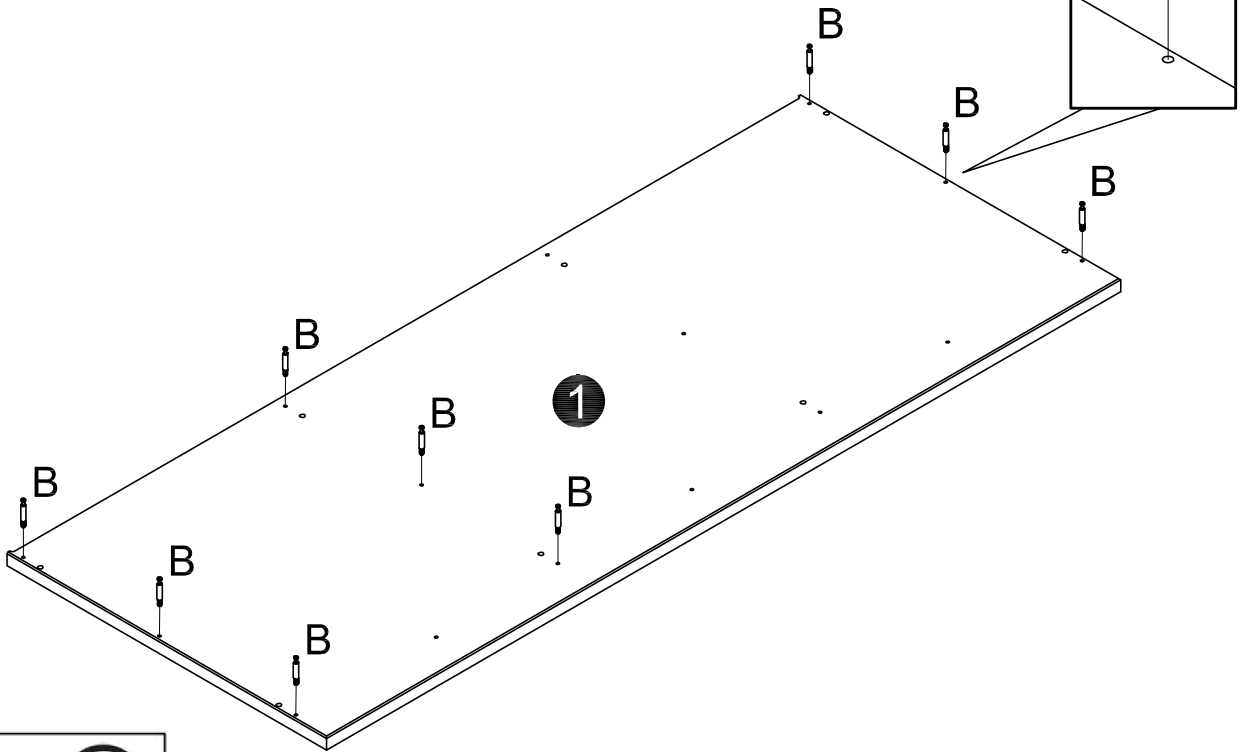
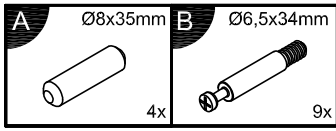

5

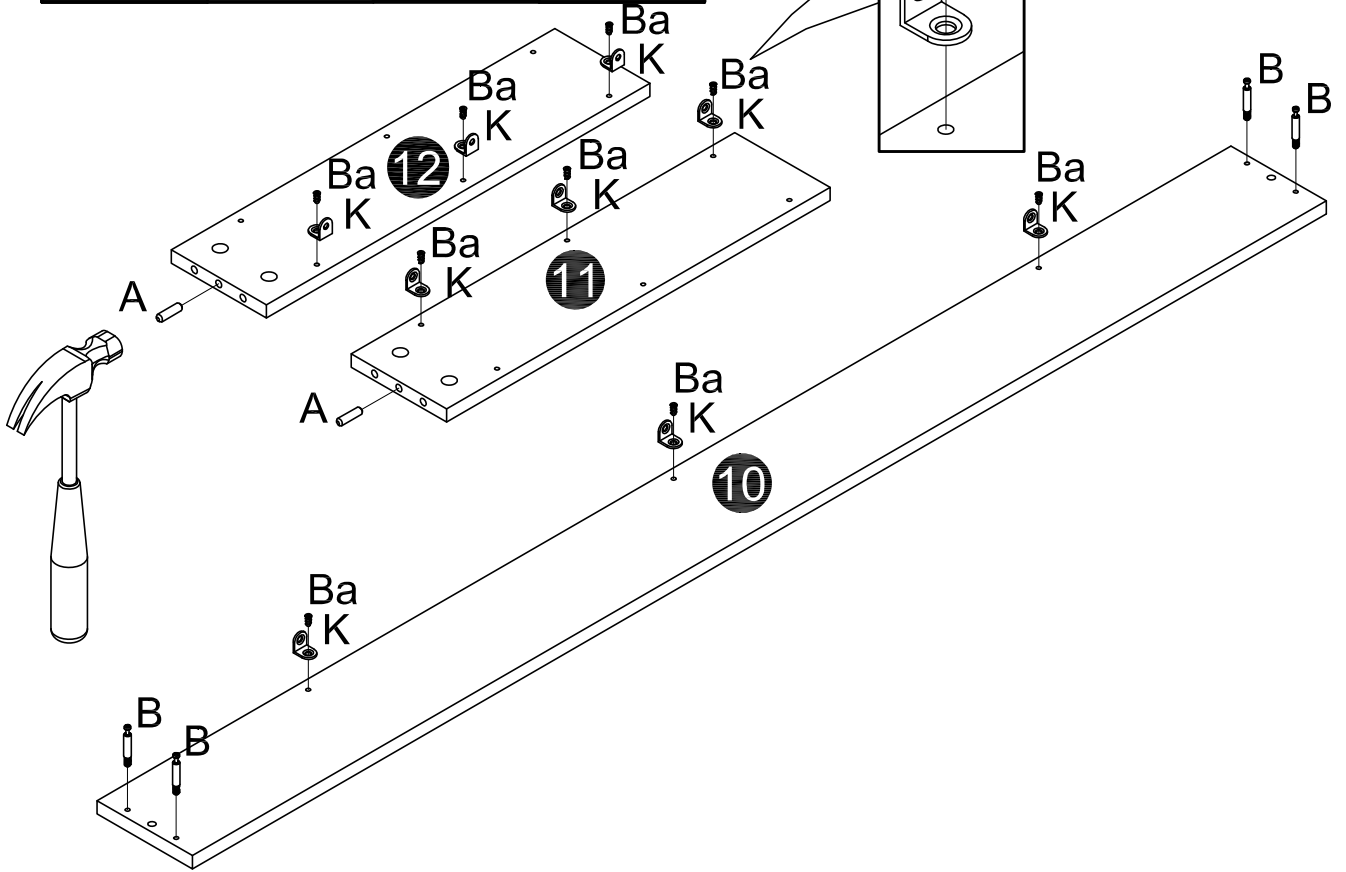
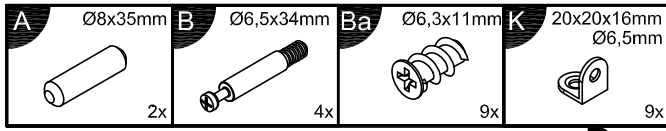

6

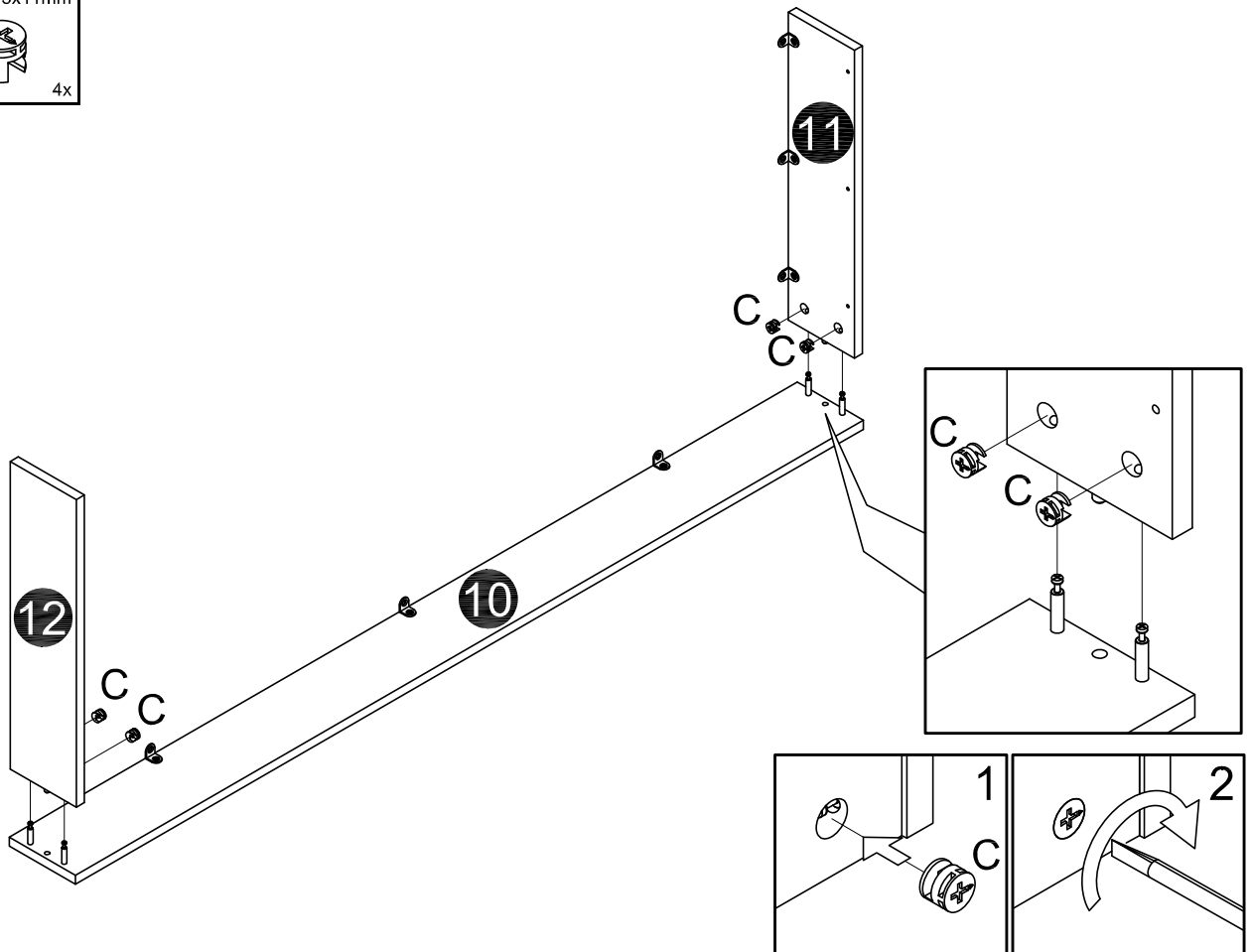
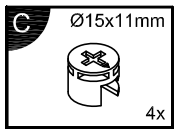

7

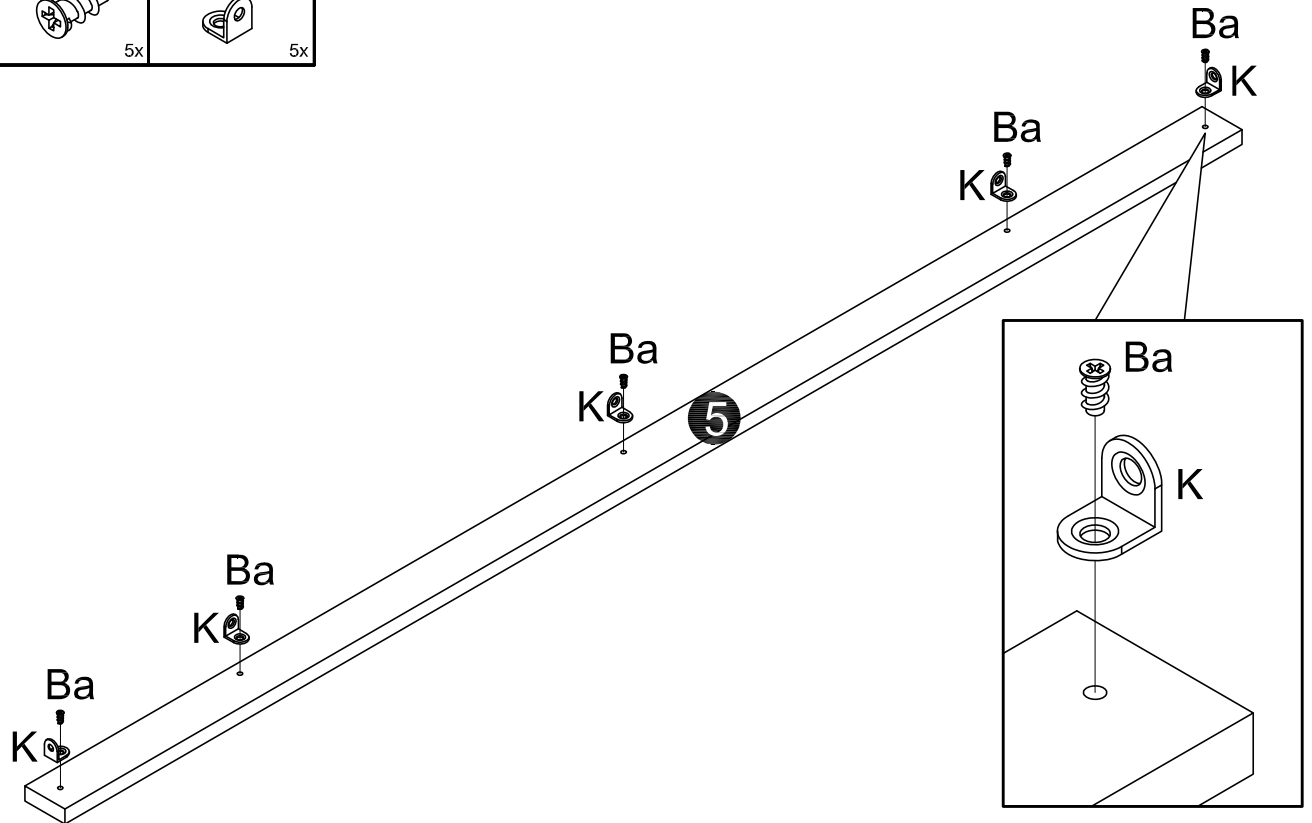
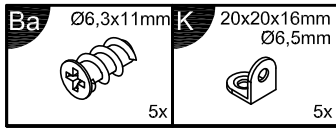

8

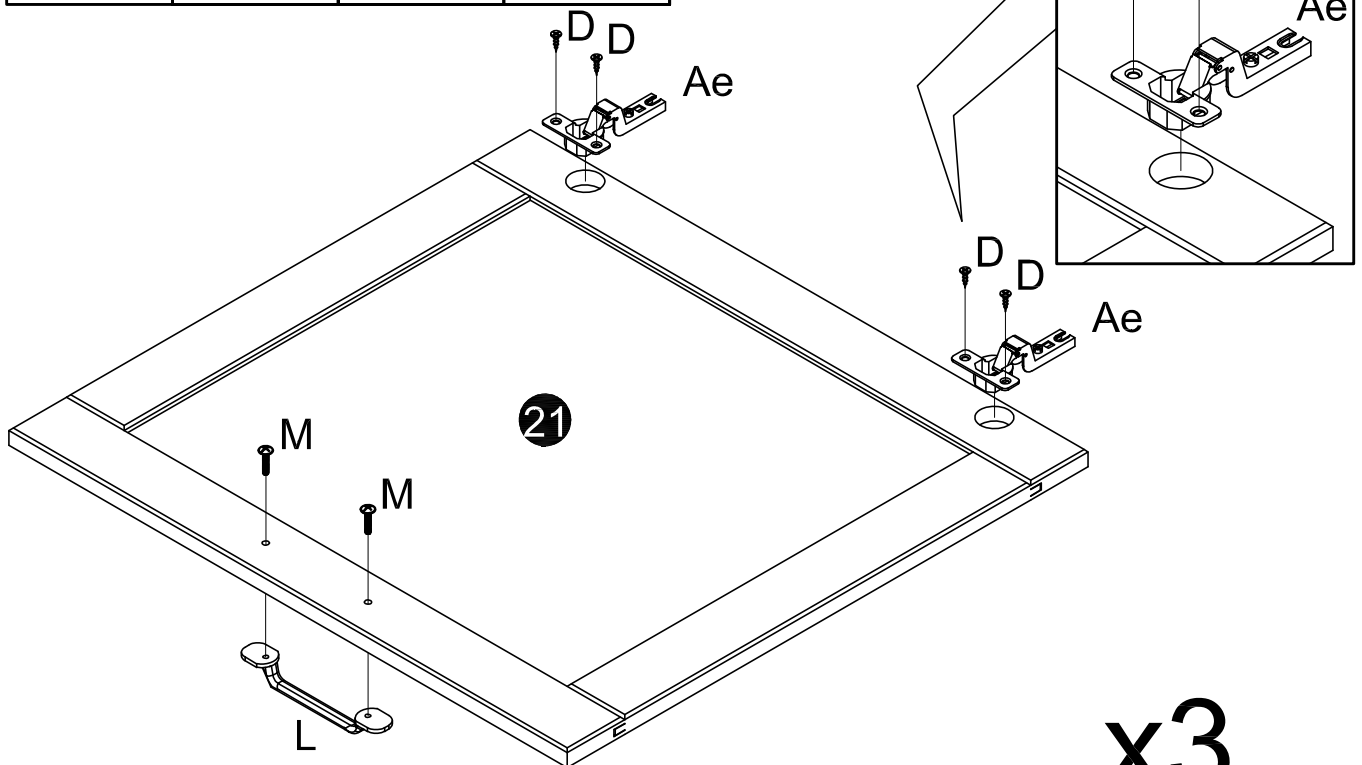
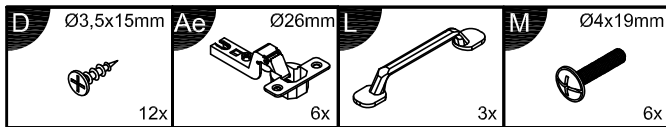

x3

9

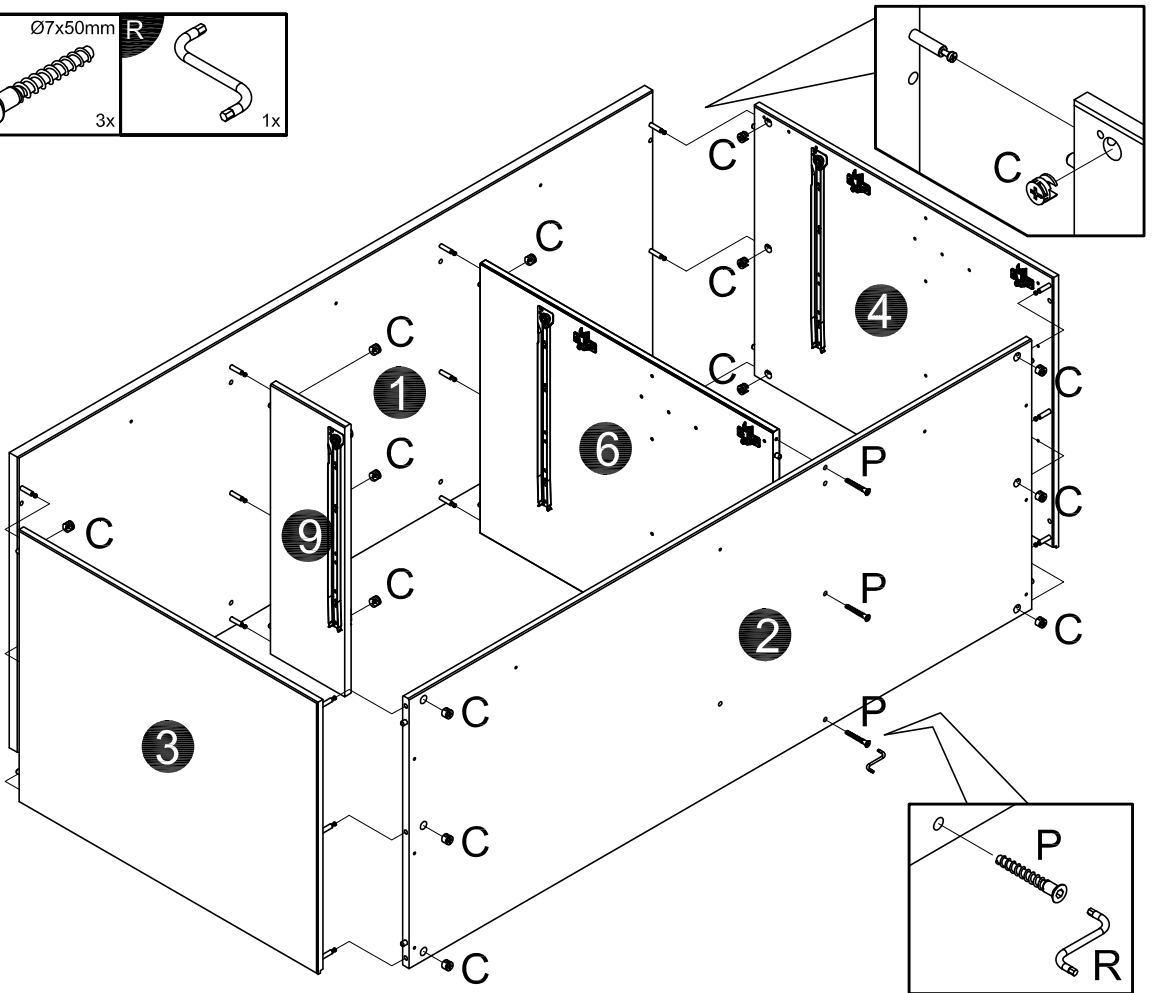
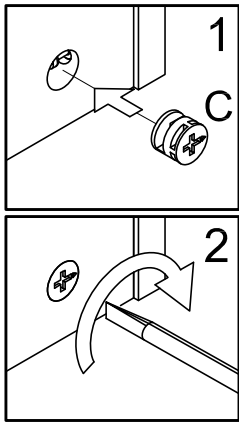
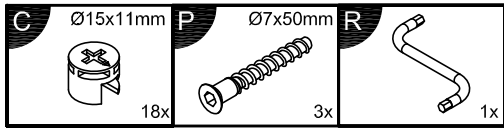

10

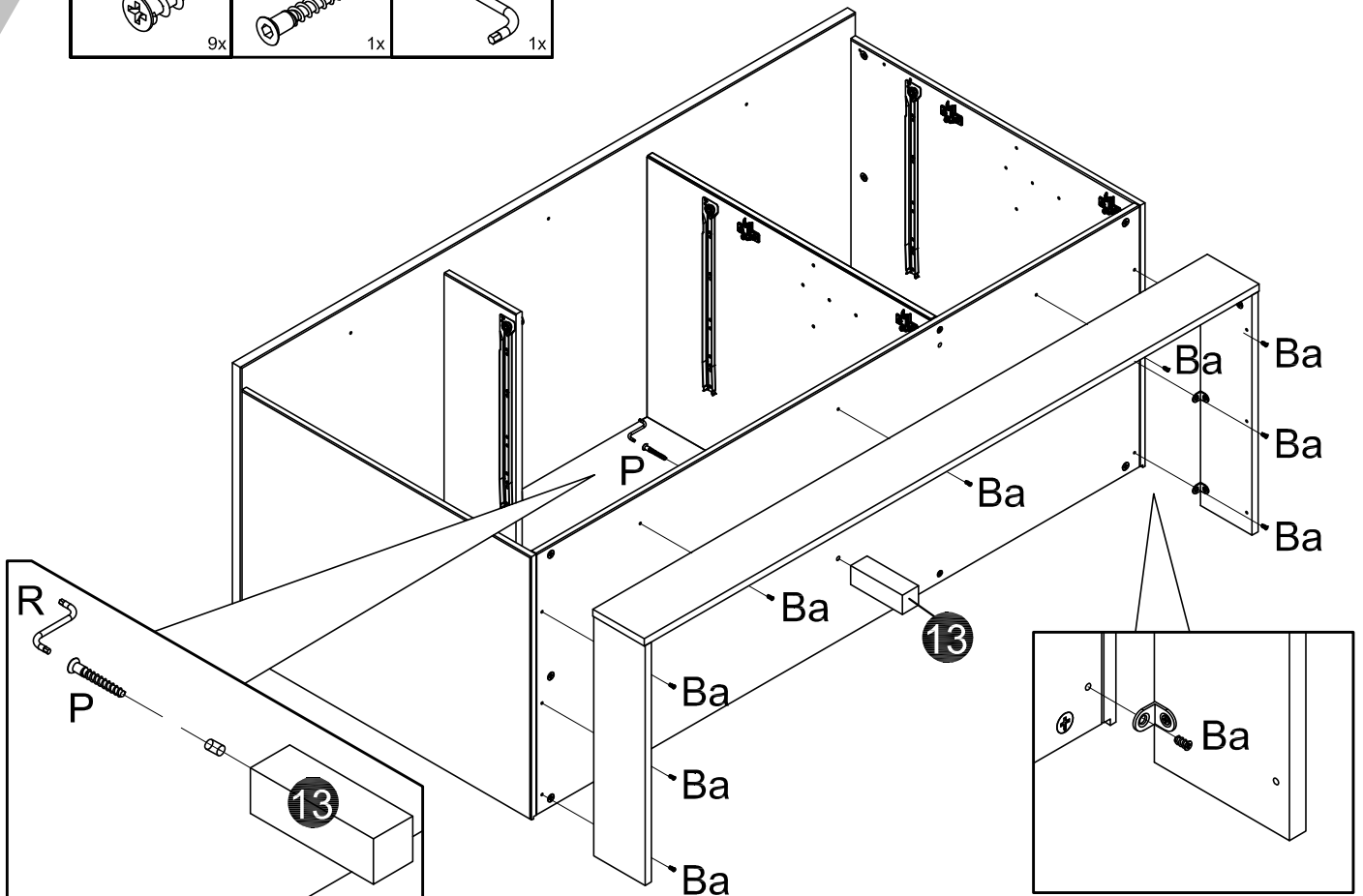
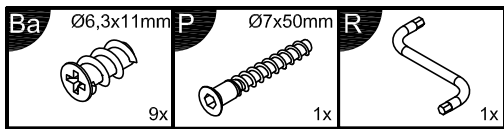

11

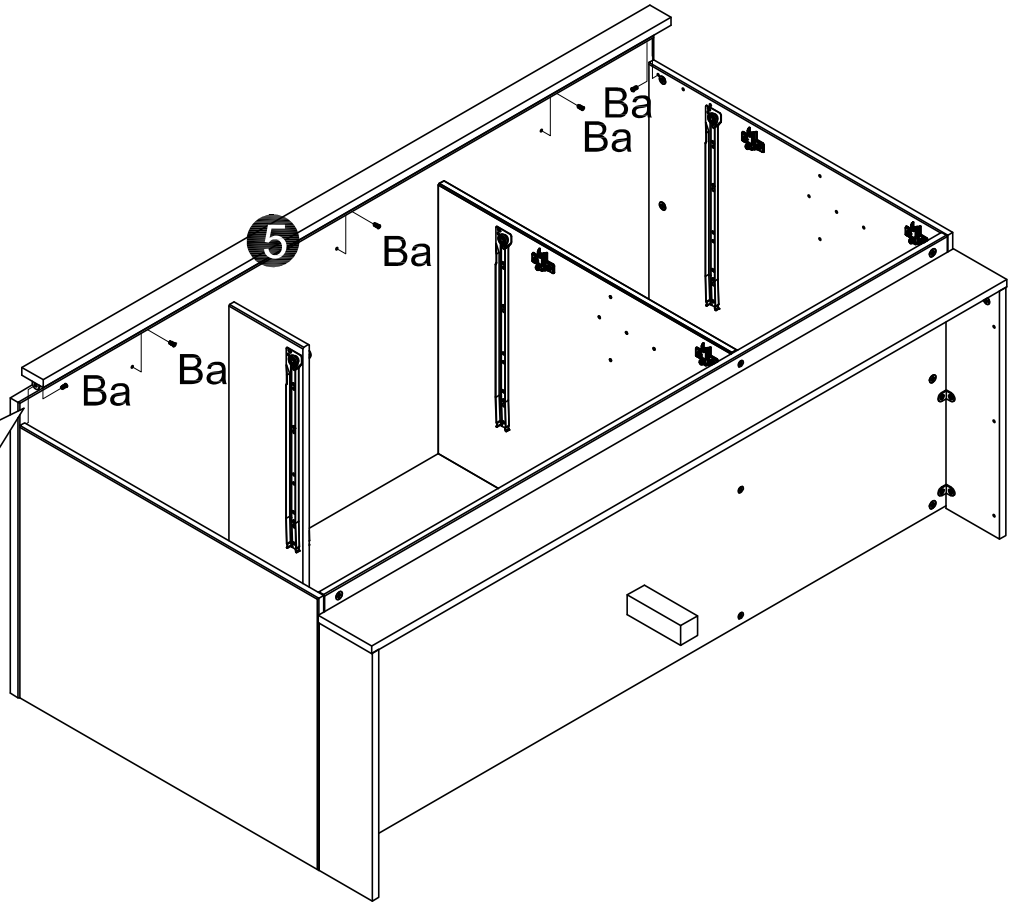
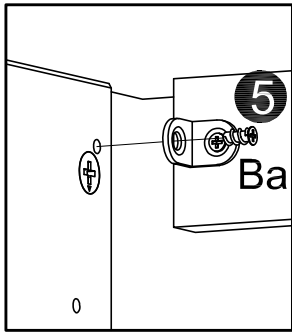
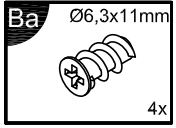

12

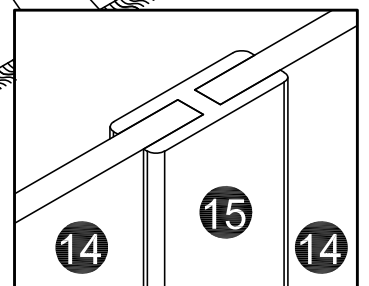
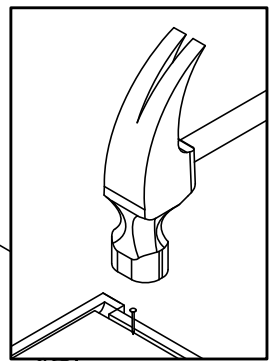
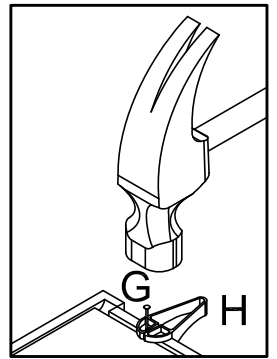
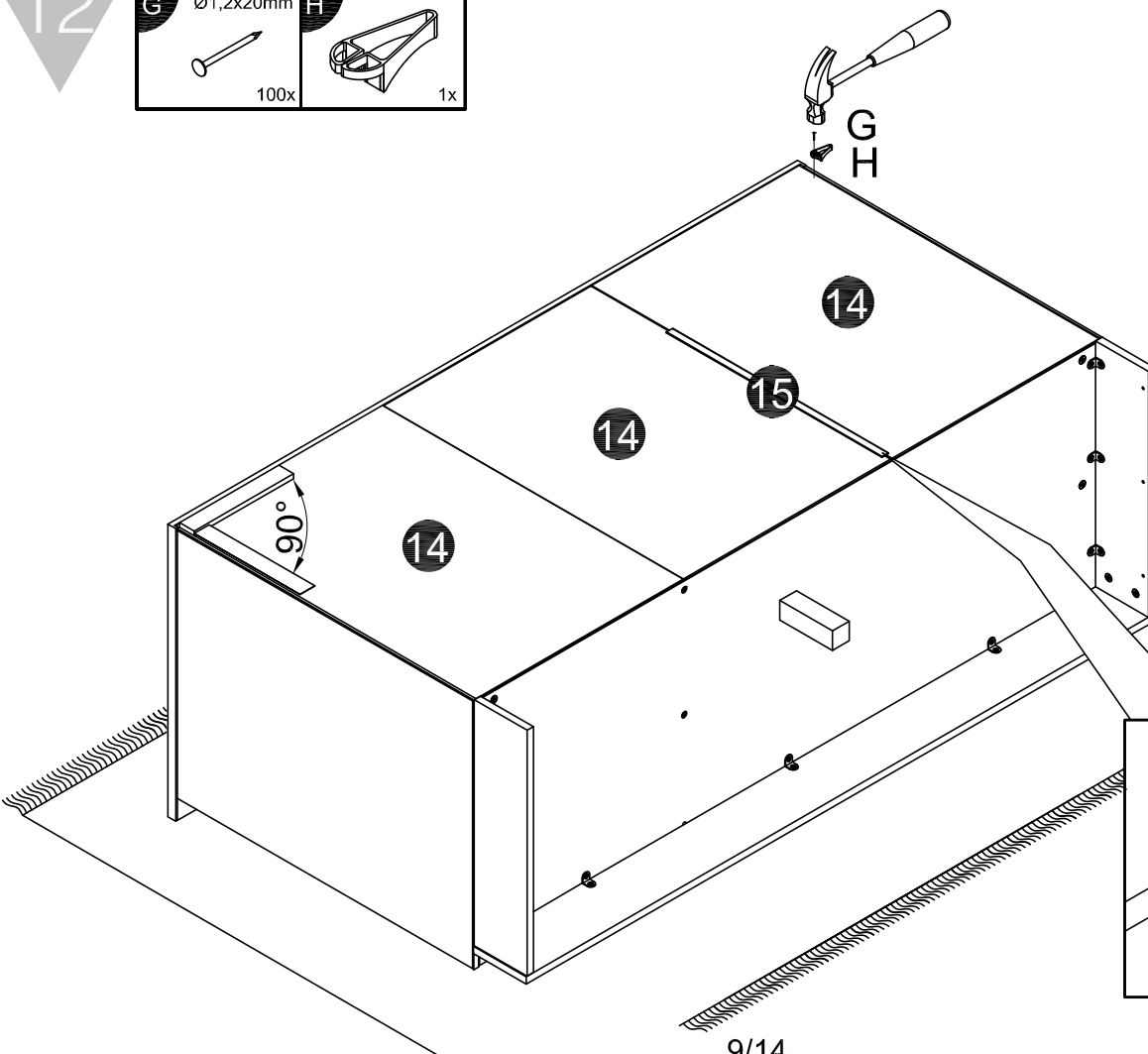
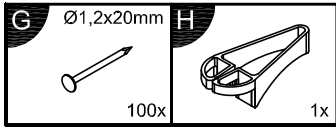

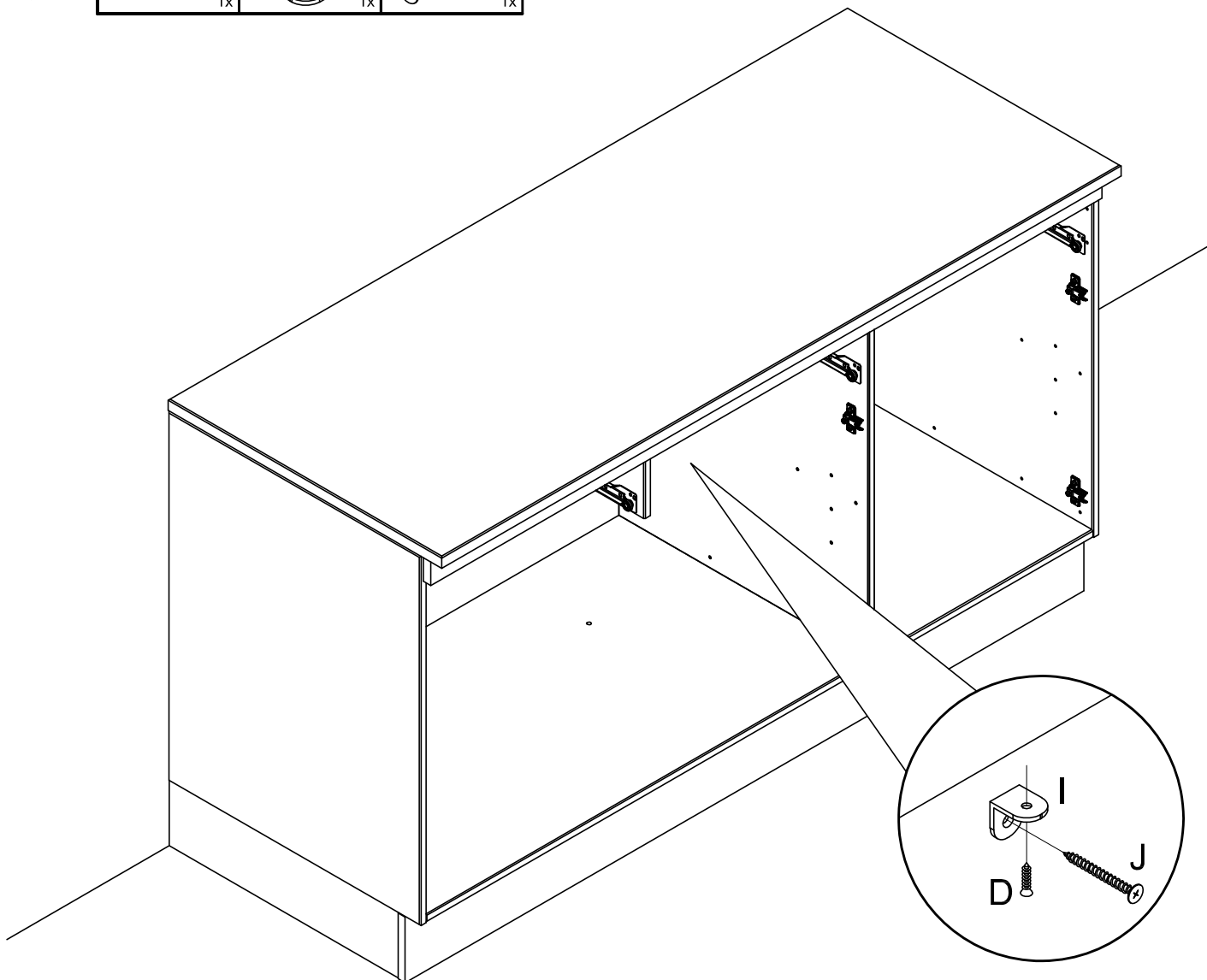
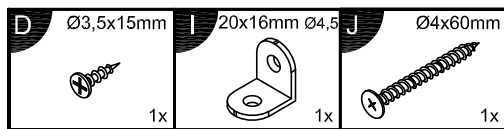

Achtung • Attention • Attenzione • Opgelet • Uwaga • Pozor • Figyelem • Aten ție • Dikkat • Вниманіе	
(D)	Wandbefestigung dient als Kippschutz - unbedingt anbringen! Bei einigen Wandtypen kann ein Spezialdübel erforderlich sein!
(GB)	The wall fastening serves to prevent tipping - be absolutely sure to mount it! For certain wall types, a special dowel may be necessary!
(NL)	Bevestiging aan de muur dient als kantelbescherming - zeker en vast bevestigen! Bij enkele muurtypes is een speciale plug misschien vereist!
(PL)	Mocowanie do ściany jest jednocześnie zabezpieczeniem przed przewróceniem - koniecznie zamontować! Do niektórych rodzajów ścian konieczne mogą być specjalne wkręty!
(TR)	Duvardaki sabitleme, devrilmeye karıştı bir emniyet tedbiridir ve mutlaka monte edilmelidir! Bazı duvar tiplerinde bunun için özel bir dübel gerekli olabilir!
(RU)	Обязательно установите крепление на стене во избежание опрокидывания! Для некоторых типов стен может потребоваться специальный дюбель!
(FR)	La fixation murale sert de protection contre le basculement — à installer impérativement ! Pour certains types de murs il faut des chevilles spéciales!
(IT)	Il fissaggio alla parete serve da protezione anti-ribaltamento - attaccarla assolutamente! Per alcune strutture di parete pu 0 essere necessario un tassello speciale!
(CZ)	Montáž na stěnu slouží jako ochrana proti převrnutí - bezpodmínečně umístěte! U některých typů stěn může být zapotřebí speciální hmoždinka!
(SK)	Upevnenie na stenu slúži ako ochrana proti prevráteniu - bezpodmienečne použite! Pre niektoré druhy stien môže byť potrebná špeciálna hmoždinka!
(HU)	A terméket a falhoz kel rögzíténi, különben az felborulhat! Egyes falt ípusoknál speciális tiplit kell használni!
(RO)	Sistemul de fixare la perete serve ște ca protecție la răsturnare de montat obligatoriu! Pentru unele tipuri de pereți este posibil să fie necesar un diblu special!

14

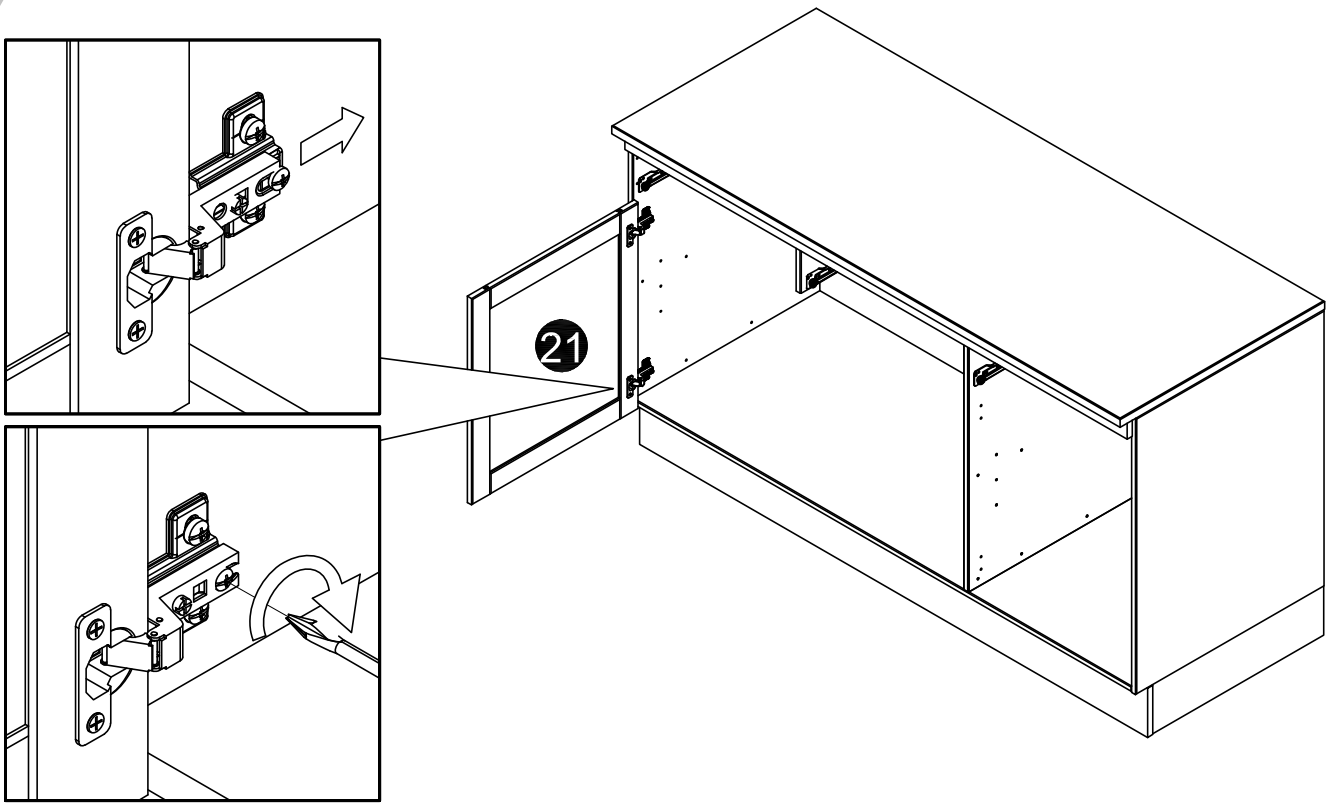

15

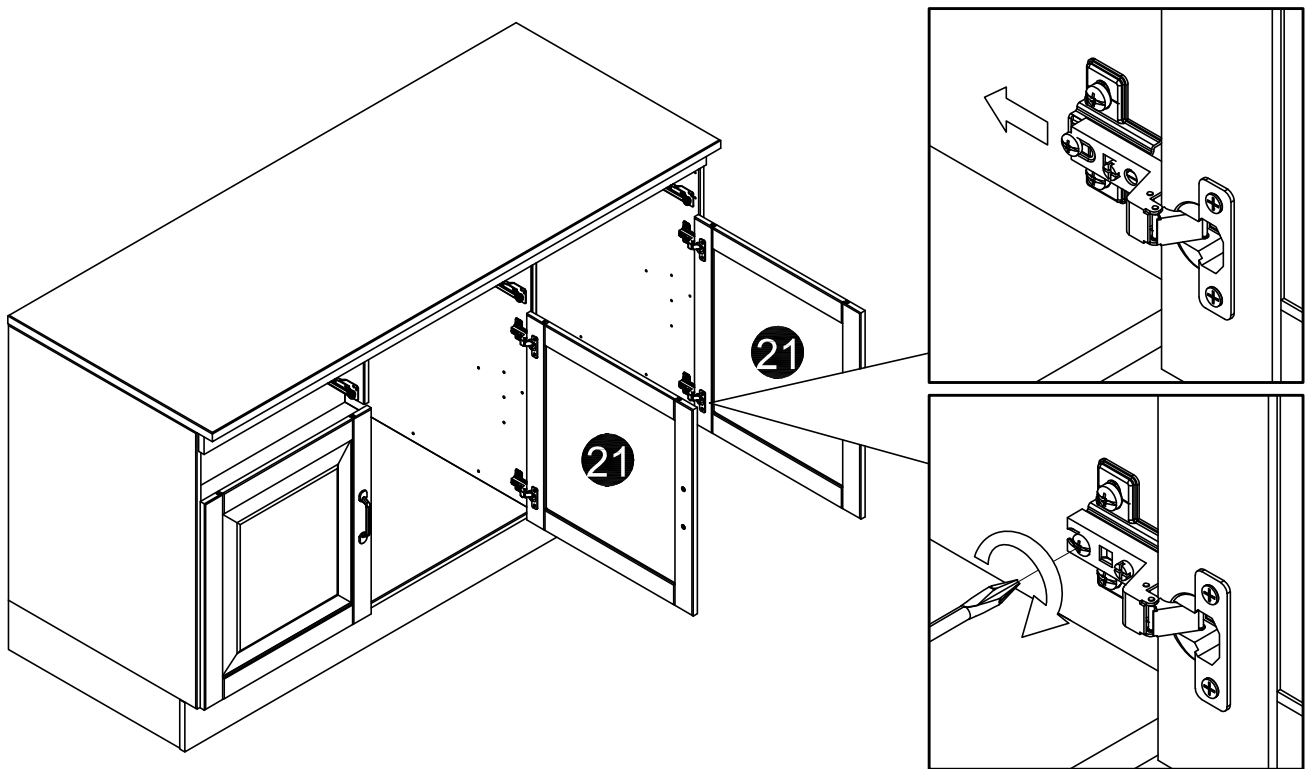

16

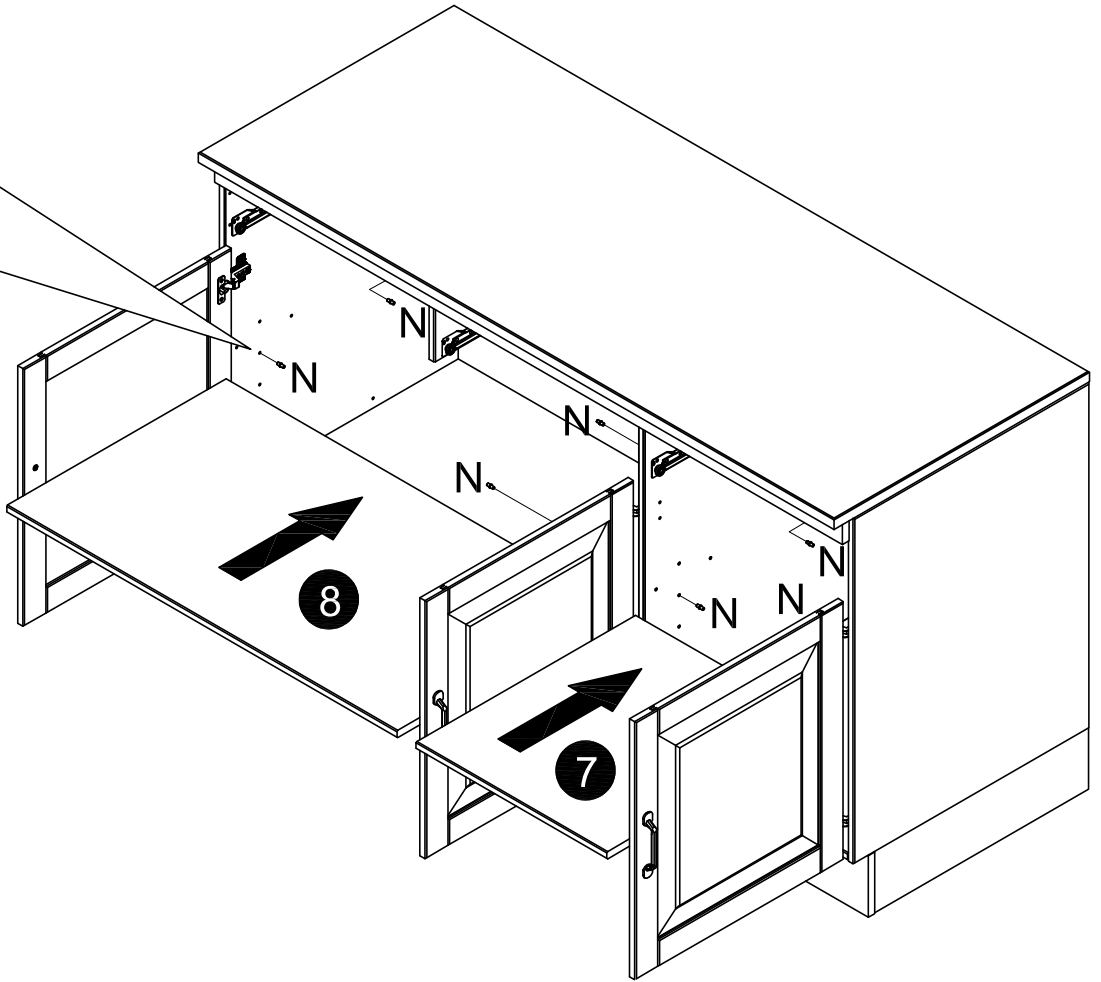
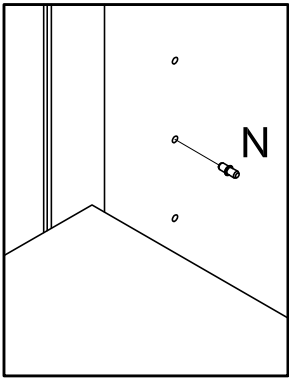
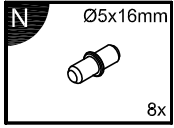

17

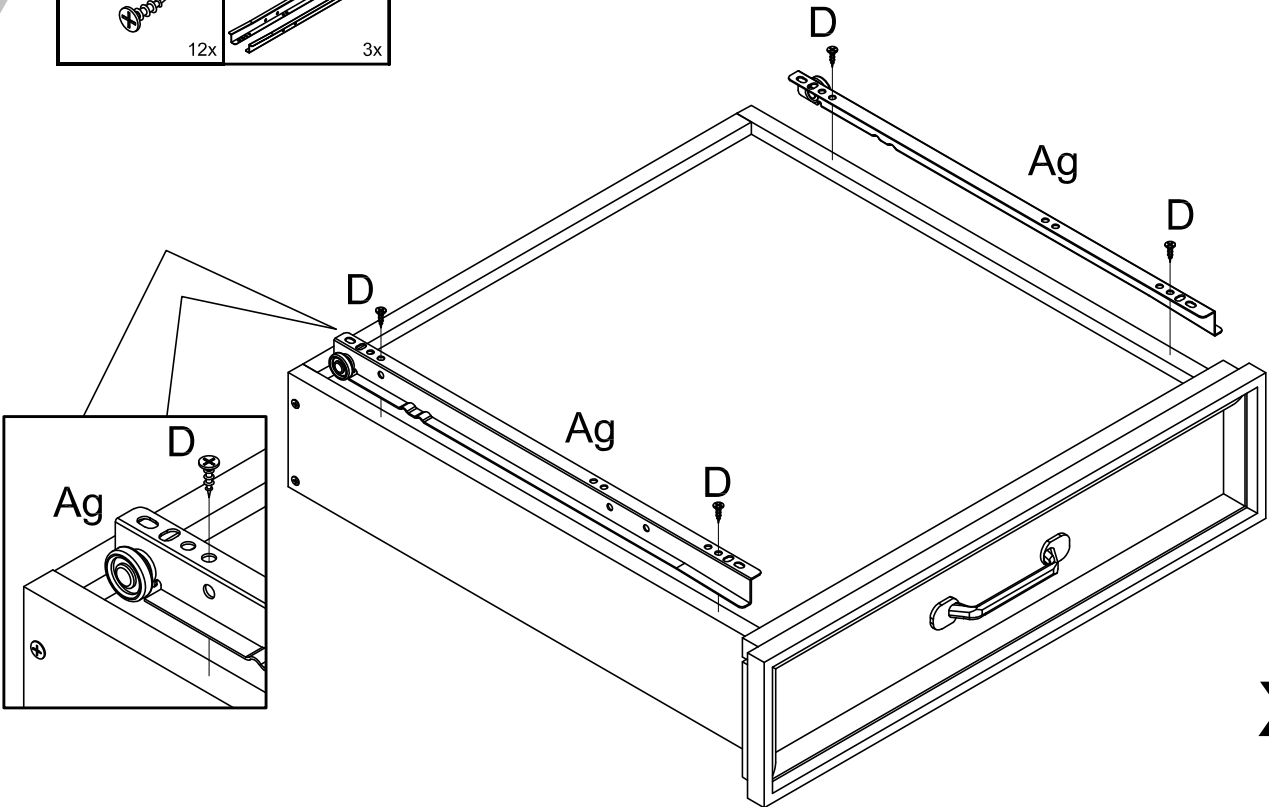
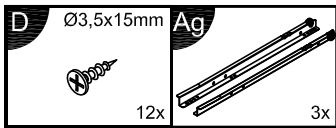

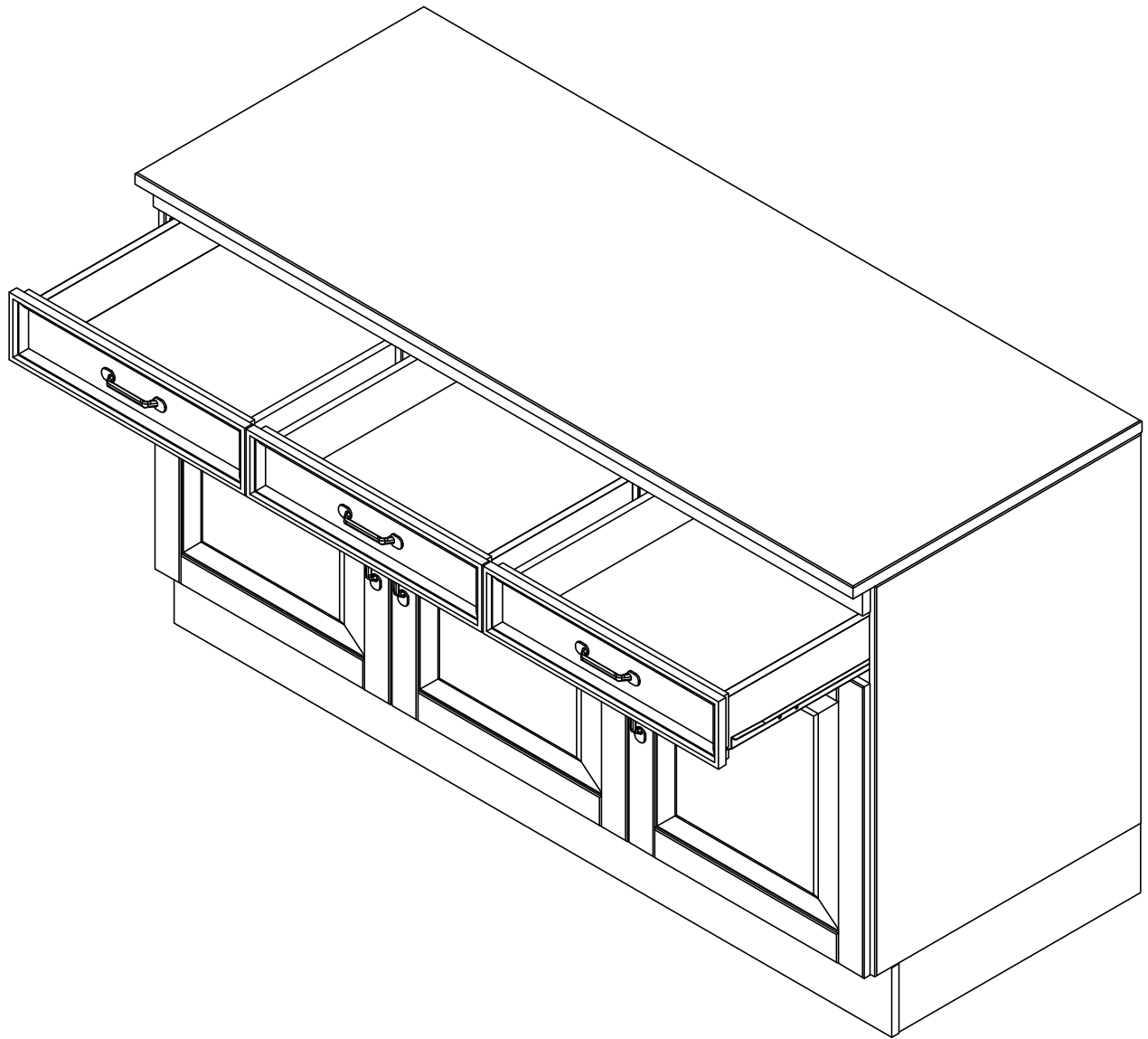

19

Türen einstellen (Scharniere justieren) Vyrovnajte dvířka (seřďte závěsy)
 Adjusting the doors (adjusting the hinges) Nastavenie dverí (nastavenie závesov)
 Régler les portes (ajuster les charnières) Állítsa be az ajtókat (állítsa be a zsanérokát)
 Sistemare le porte (regolare le cerniere) Reglare uși (ajustare balamale)
 Deuren instellen (scharnieren afstellen) Kapıların ayarlanması (menteşelerin seviye ayarı)
 Nastawić drzwi (wyregulować zawiasy) Регулировка дверей (регулировка шарнира)

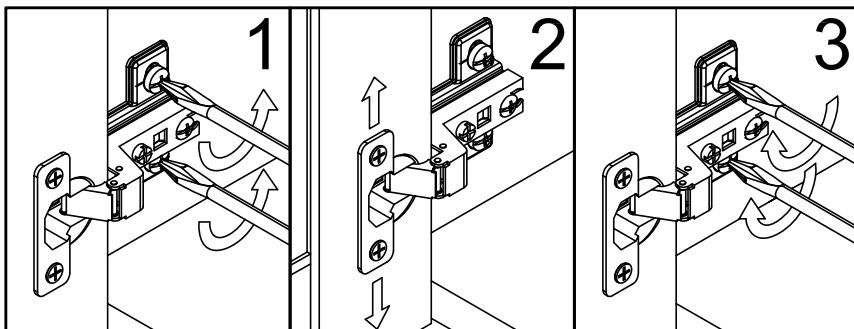
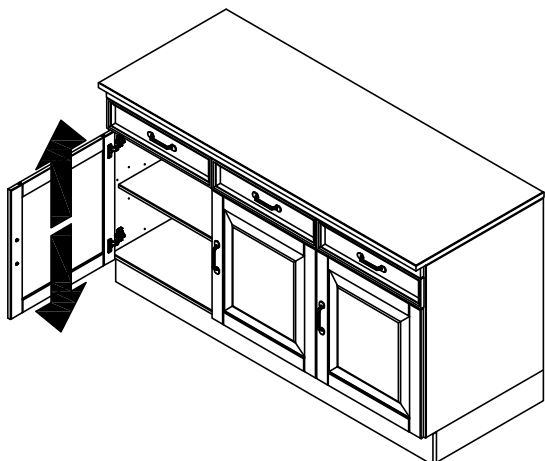

20

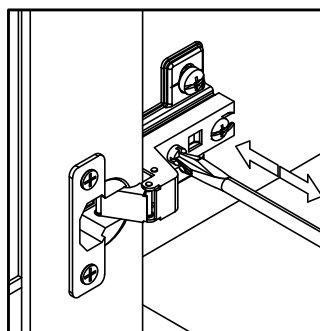
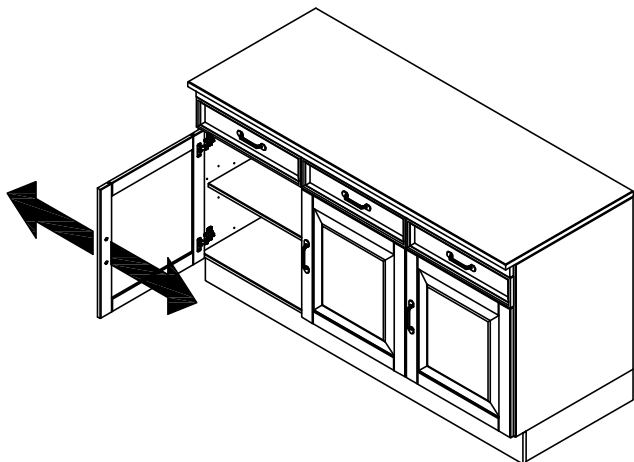

21

