

SKU N620P191038

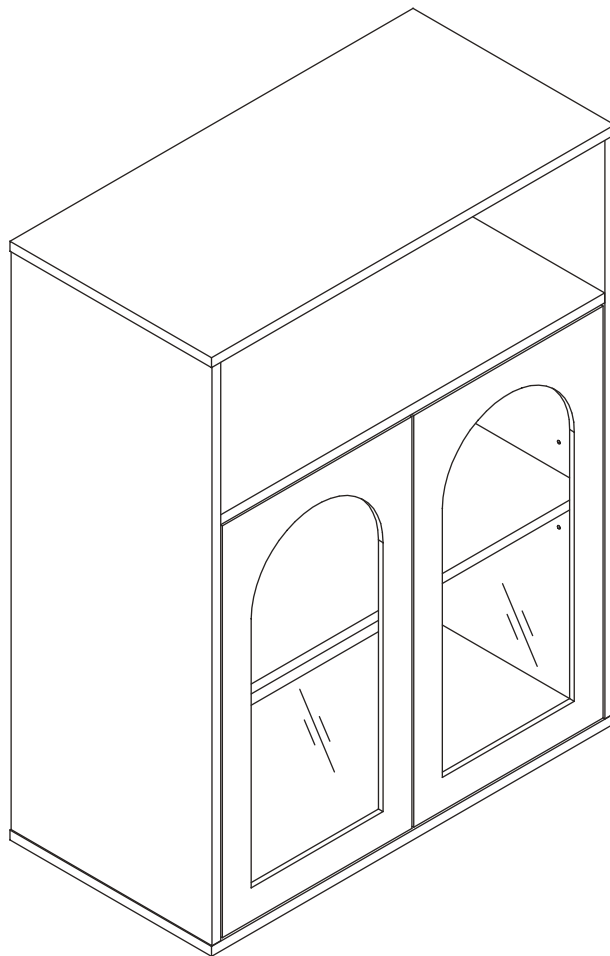

FR

Vous êtes responsable de remettre tous les appareils électriques et électroniques usagés à des points de collecte correspondants.

Pour en savoir plus:
www.quefairedeusdechets.fr

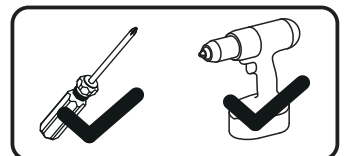
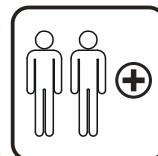

EN_IMPORTANT, RETAIN FOR FUTURE REFERENCE: READ CAREFULLY.

FR_IMPORTANT: A LIRE ATTENTIVEMENT ET À CONSERVER POUR CONSULTATION ULTÉRIEURE.

ES_IMPORTANTE, LEA Y GUARDE PARA FUTURAS REFERENCIAS.

DE_„WICHTIG! SORGFÄLTIG LESEN UND FÜR SPÄTER NACHSCHLAGEN AUFBEWAHREN.“

IT_IMPORTANTE! CONSERVARE IL PRESENTE MANUALE PER FUTURO RIFERIMENTO E LEGGERLO ATTENTAMENTE.

Warnung

1. Die maximale Tragfähigkeit der Produktoberplatte beträgt 60 kg. Überlastung vermeiden.
2. Bitte Kinder nicht auf das Möbel klettern lassen, da dies zu Umkippen und schweren Verletzungen führen kann.
3. Zur Sicherheit bitte die Anweisungen korrekt befolgen und gegebenenfalls professionelle Hilfe in Anspruch nehmen.
4. Das Möbel nicht in der Nähe von Hitzequellen oder heißen Gegenständen platzieren, um Brandgefahr zu vermeiden.
5. Das Möbel nicht in feuchten Umgebungen aufstellen, um Schäden am Material zu vermeiden.
6. Regelmäßige Überprüfung aller Verbindungsstücke und Befestigungen, um sicherzustellen, dass sie fest sitzen und unerwartete Unfälle zu verhindern.
7. Das Produkt ist mit einem Kippschutz ausgestattet, um Verletzungen durch Umkippen zu verhindern.

Warning

- 1 The maximum load-bearing capacity of the product top panel is 60 kg. Do not overload.
- 2 Please do not allow children to climb on furniture, as this may result in tipping and serious injuries.
- 3 For safety, please follow the instructions correctly and seek professional assistance if necessary.
- 4 Do not place furniture near heat sources or hot items to avoid the risk of fire.
- 5 Do not place furniture in damp environments to prevent material damage.
- 6 Regularly check all fittings and fastenings to ensure they are secure and to prevent accidents.
- 7 This product comes with an anti-tip device to prevent injuries from tipping.

Avertissement

- 1 La capacité de charge maximale du plateau supérieur du produit est de 60 kg. Ne pas surcharger.
- 2 Veuillez ne pas laisser les enfants grimper sur les meubles, car cela peut entraîner un basculement et des blessures graves.
- 3 Pour des raisons de sécurité, veuillez suivre correctement les instructions et demander de l'aide professionnelle si nécessaire.
- 4 Ne pas placer les meubles près de sources de chaleur ou d'objets chauds pour éviter tout risque d'incendie.
- 5 Ne pas placer les meubles dans des environnements humides pour éviter les dommages matériels.
- 6 Vérifiez régulièrement tous les raccords et fixations pour vous assurer qu'ils sont bien serrés et pour éviter les accidents.
- 7 Ce produit est équipé d'un dispositif anti-basculement pour éviter les blessures en cas de basculement.

Avviso

- 1 La capacità massima di carico del piano superiore del prodotto è di 60 kg. Non sovraccaricare.
- 2 Si prega di non permettere ai bambini di arrampicarsi sui mobili, poiché ciò potrebbe causare il ribaltamento e gravi lesioni.
- 3 Per motivi di sicurezza, seguire correttamente le istruzioni e richiedere assistenza professionale se necessario.
- 4 Non posizionare i mobili vicino a fonti di calore o oggetti caldi per evitare il rischio di incendio.
- 5 Non posizionare i mobili in ambienti umidi per evitare danni al materiale.
- 6 Controllare regolarmente tutti i raccordi e i fissaggi per assicurarsi che siano saldi e per evitare incidenti.
- 7 Questo prodotto è dotato di un dispositivo anti-ribaltamento per evitare lesioni dovute al ribaltamento.

Aviso

- 1 La capacidad máxima de carga del panel superior del producto es de 60 kg. No sobrecargar.
- 2 Por favor, no permita que los niños trepen sobre los muebles, ya que esto podría provocar que se vuelquen y causar lesiones graves.
- 3 Por seguridad, siga correctamente las instrucciones y solicite ayuda profesional si es necesario.
- 4 No coloque los muebles cerca de fuentes de calor o objetos calientes para evitar el riesgo de incendio.
- 5 No coloque los muebles en entornos húmedos para evitar daños en el material.
- 6 Revise regularmente todas las conexiones y sujeciones para asegurarse de que estén firmes y para evitar accidentes.
- 7 Este producto viene con un dispositivo antivuelco para evitar lesiones por vuelco.

Vor dem Einbau die Schrauben in die Löcher stecken und festziehen, aber nicht bis 100%, 70% bis 80% anziehen reicht aus. Schließlich, nachdem alle Schrauben installiert sind, ziehen Sie alle Schrauben auf 100%.

Wenn Sie auf diese Probleme stoßen, wie z. B. Fehlausrichtung der Löcher oder Unfähigkeit, bestimmte Teile zu installieren, überprüfen Sie bitte, ob die Schrauben korrekt verwendet werden und passen Sie die Dichtigkeit der Schrauben an.

Before installation, insert the screws into the holes and tighten them, but do not tighten them to 100%, 70% to 80% is sufficient. Finally, after all screws are installed, tighten all screws to 100%.

If you encounter these issues, such as if the holes cannot be aligned or some parts cannot be installed, please check if the screws are used correctly and adjust the tightness of the screws.

Insérer la vis dans le trou avant la fin de l'assemblage, serrer la vis, mais ne pas serrer à 100%, 70% ~ 80% est correct. Enfin, une fois que toutes les vis sont bien serrées, toutes les vis sont serrées à 100%.

Si vous rencontrez ces problèmes, par exemple si les trous ne sont pas alignés ou si certaines pièces ne peuvent pas être montées, vérifiez que les vis sont utilisées correctement et Ajustez leur serrage.

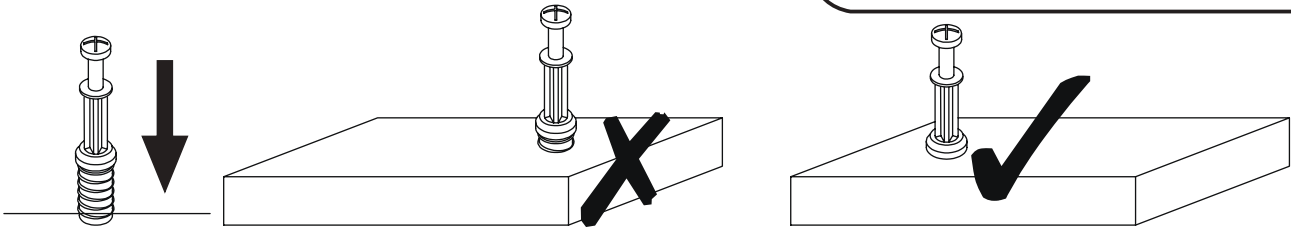

EN_QUICKFIT: Tighten quickfit until shoulder is flush with panel. Do not overtighten or undertighten.

FR_RACCORD RAPIDE: Faites serrer le raccord rapide jusqu'à ce que l'épaulement soit parfaitement encastré dans le panneau. Il ne faut ni trop serrer ni insuffisamment serrer.

ES_QUICKFIT: Apriete quickfit hasta que el hombro se descargue con el panel. NO lo sobreapriete ni lo apriete poco.

DE_QUICKFIT: Ziehen Sie den Quickfit fest, bis die Schulter mit der Platte bündig ist. Bitte nicht zu fest oder zu schwach anziehen.

IT_MONTAGGIO RAPIDO: Stringere il montaggio rapido fino a quando la spalla è a filo con il pannello, non stringere troppo o troppo poco.

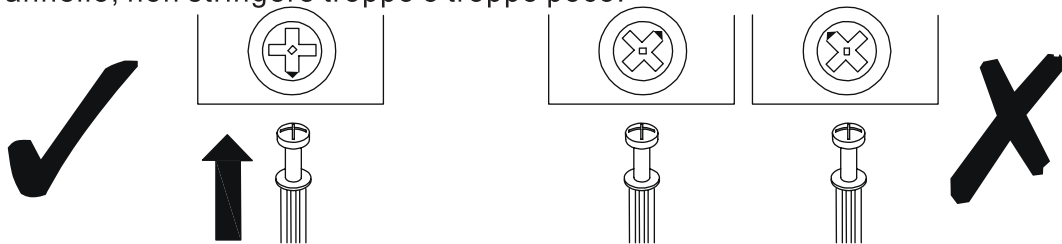

EN_CAM LOCK: When fitting cam lock, ensure starting position is correct before you insert connecting quickfit.

FR_SERRURE BATTEUSE: Avant d'insérer la serrure batteuse, veillez à la bonne orientation avant d'insérer le raccord rapide.

ES_CIERRE DE LA CÁMARA: Cuando instale el cierre de la cámara, asegúrese de que la posición de inicio es correcta antes de que inserte el quickfit conector.

DE_CAM-LOCK: Achten Sie bei der Montage des Cam-Locks auf die richtige Ausgangsposition, bevor Sie den Quickfit einsetzen.

IT_BLOCCAGGIO A CAMMA: Quando si monta il bloccaggio a camma, assicurarsi che la posizione iniziale sia corretta prima di inserire il montaggio rapido di collegamento.

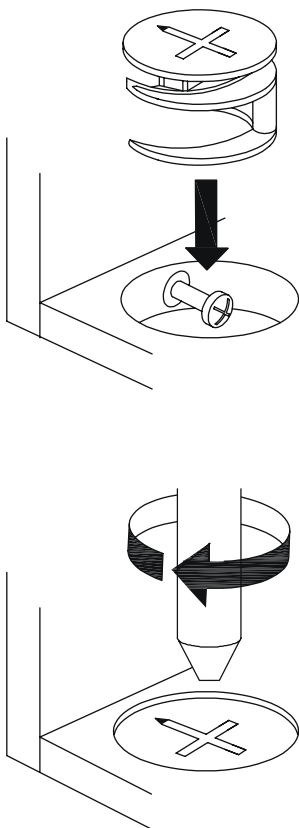

EN_Quickfit head should be in the centre of the cam lock when the two panels are joined.

Cam lock should be inserted before quickfit.

FR_Lorsque les deux panneaux sont assemblés, la tête du raccord rapide doit reposer au centre de la serrure batteuse.

Il faut insérer la serrure batteuse avant le raccord rapide.

ES_El cabezal del quickfit debe estar en el centro del cierre de la cámara cuando se unan los dos paneles.

Se debe insertar el cierre de la cámara antes que el quickfit.

DE_Der Quickfit-Kopf sollte sich in der Mitte des Cam-Locks befinden, wenn die beiden Platten zusammengefügt sind.

Der Cam-Lock sollte vor dem Quickfit eingesetzt werden.

IT_La testa del montaggio rapido deve trovarsi al centro del bloccaggio a camma quando i due pannelli sono uniti.

Il Bloccaggio a Camma deve essere inserito prima del montaggio rapido.

EN_Turn cam lock clockwise to tighten.



FR_Faites tourner la serrure batteuse dans le sens des aiguilles d'une montre pour la resserrer.

ES_Gire el cierre de la cámara en sentido horario para apretarlo.

DE_Drehen Sie den Cam-Lock im Uhrzeigersinn, um ihn festzuziehen.

IT_Ruotare il bloccaggio a camma in senso orario per stringere.

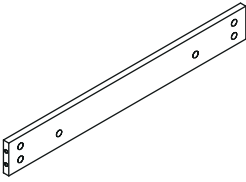
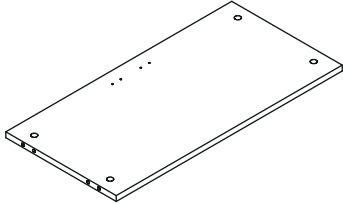
N620P191038

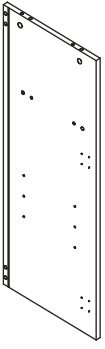
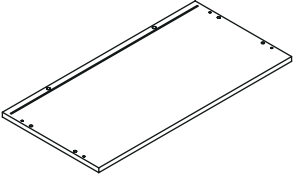
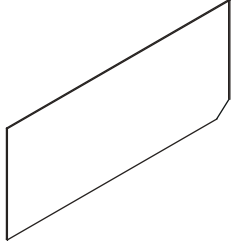
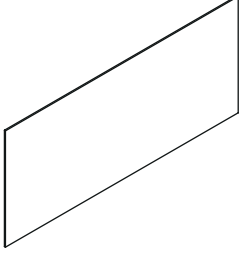
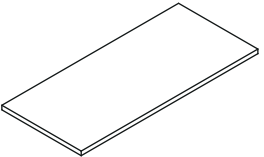
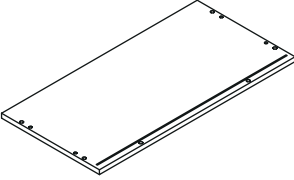
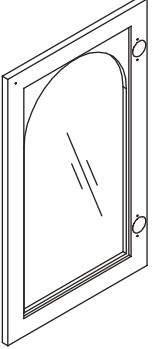
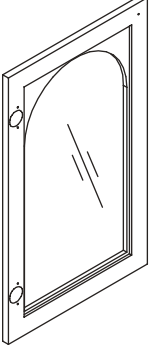
			
① x 2	② x 1	③ x 1	④ x 1
			
⑤ x 1	⑥ x 2	⑦ x 1	⑧ x 1
			
⑨ x 1	⑩ x 1	⑪ x 1	



DE:Bitte beachten Sie, dass die Formen der Schrauben G und L2 ähnlich sind. Bitte installieren Sie entsprechend der Anleitung und unterscheiden Sie sie!

UK:Please note that the shapes of screws G and L2 are similar. Please install according to the instructions and distinguish them!

FR:Notez que les vis G et L2 ont des formes similaires. Veuillez les installer en suivant les instructions pour les séparer!

PARTS

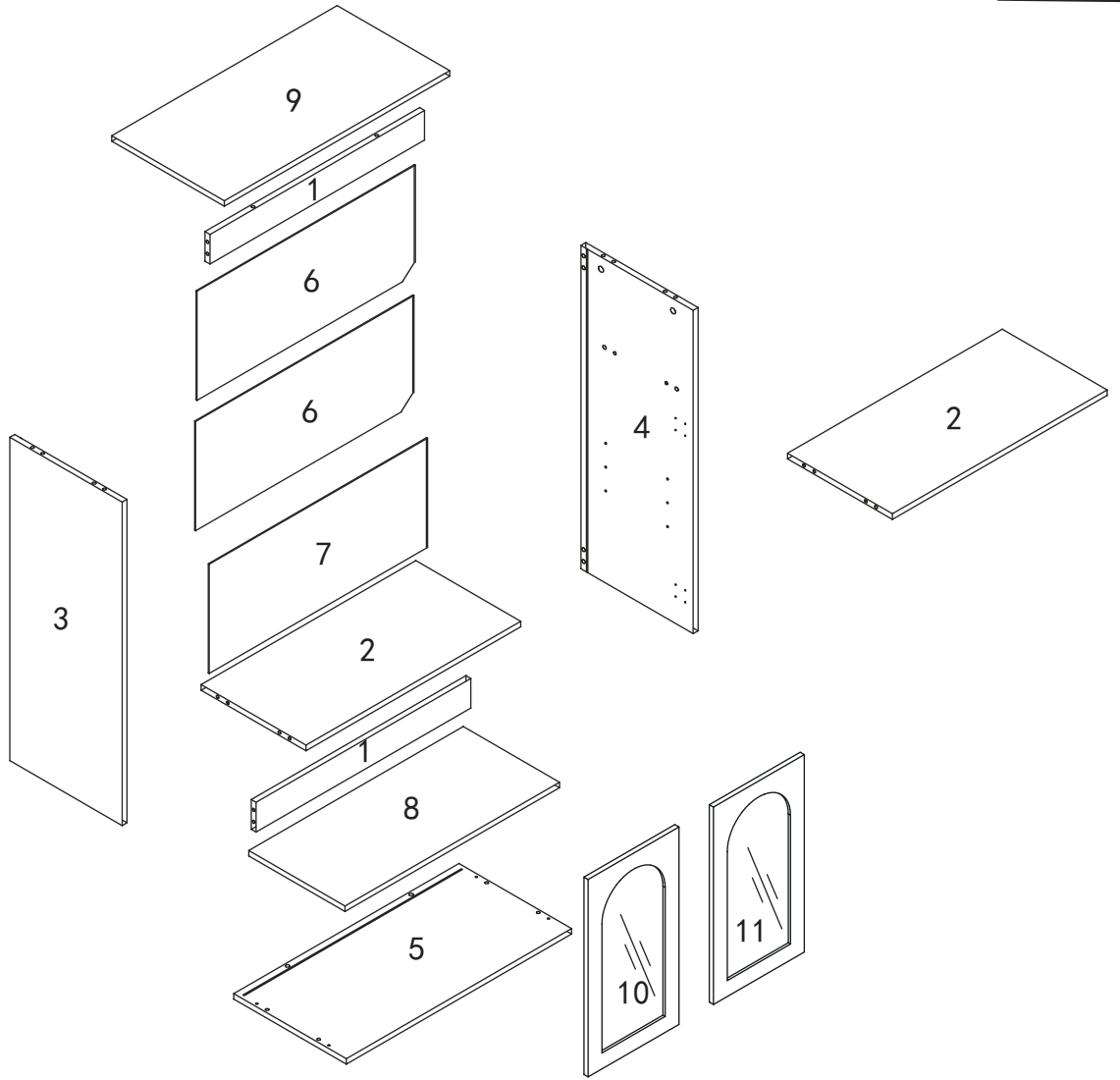

HARDWARE

A 20+2 pcs



B 20+2 pcs



C 12+2 pcs



∅8 x 30 mm

D2
12+2pcs
∅3.5 x 14 mm



12+2pcs

E 4 pcs

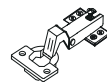

F 4+1 pcs



G 28+2pcs



∅3.5 x 14 mm

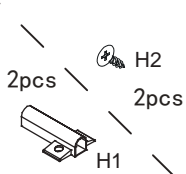

2pcs

H2

2pcs

H1

J 4+1 pcs



K 6+1 pcs

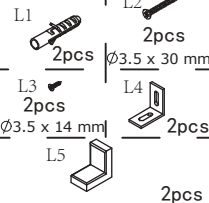

L1

2pcs

L2

2pcs

∅3.5 x 30 mm

L3

2pcs

L4

2pcs

∅3.5 x 14 mm

L5

2pcs

M 4+1 pcs



∅5 x 40 mm

N 1 pcs



P 1 pcs



LED

1.

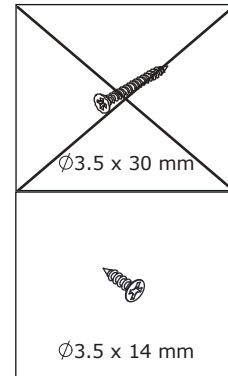
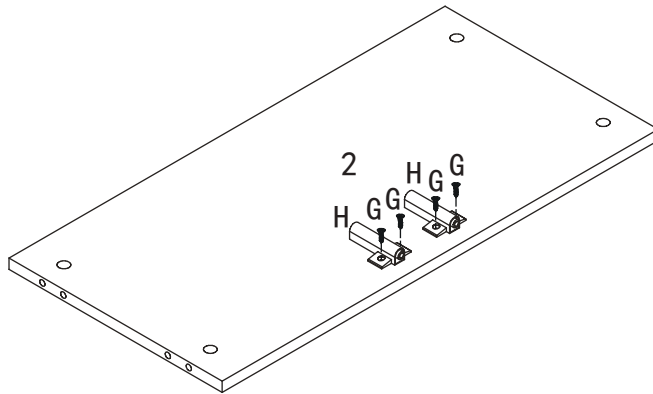

H*2



G*4



$\varnothing 3.5 \times 14 \text{ mm}$

2.

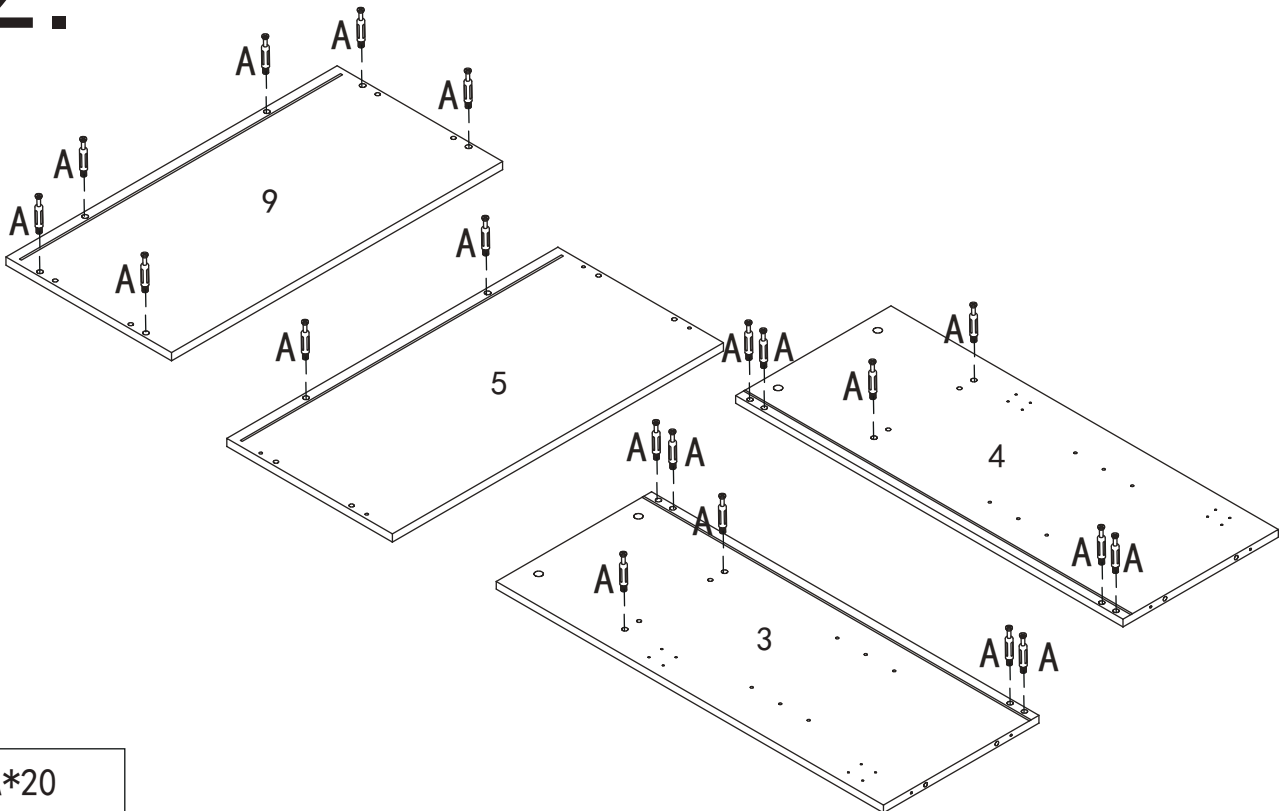

A*20

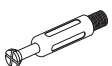

3.

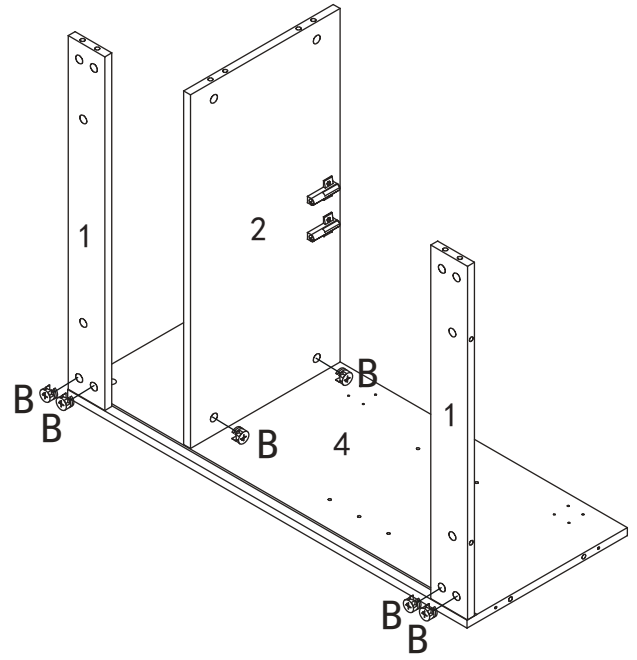
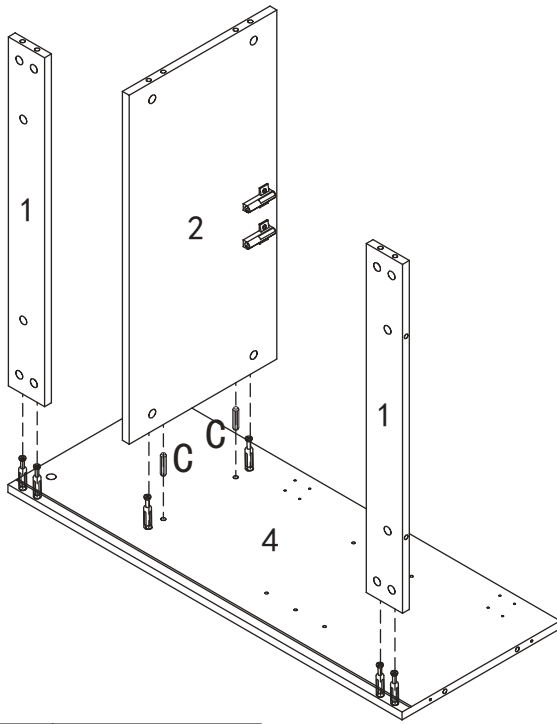

C*2



Ø8 x 30 mm

B*6



4.

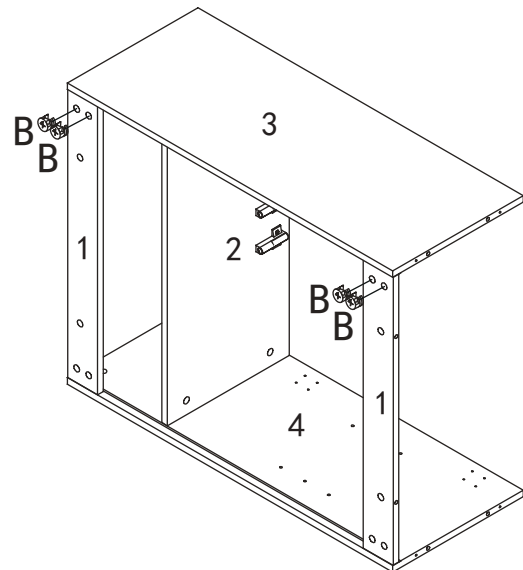
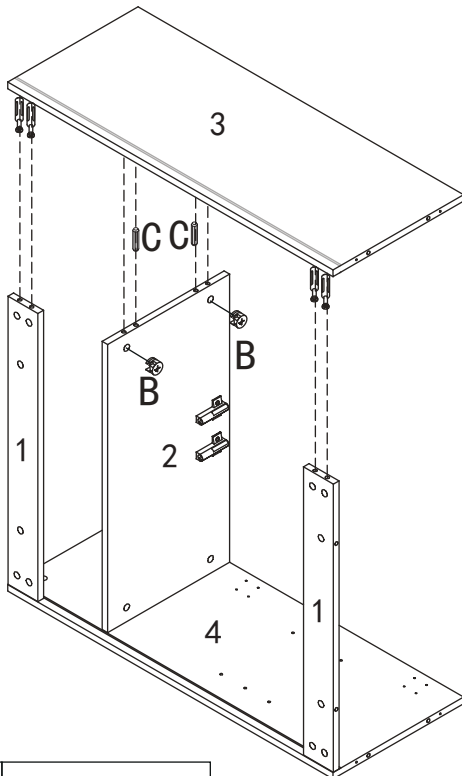

C*2







Ø8 x 30 mm

B*6

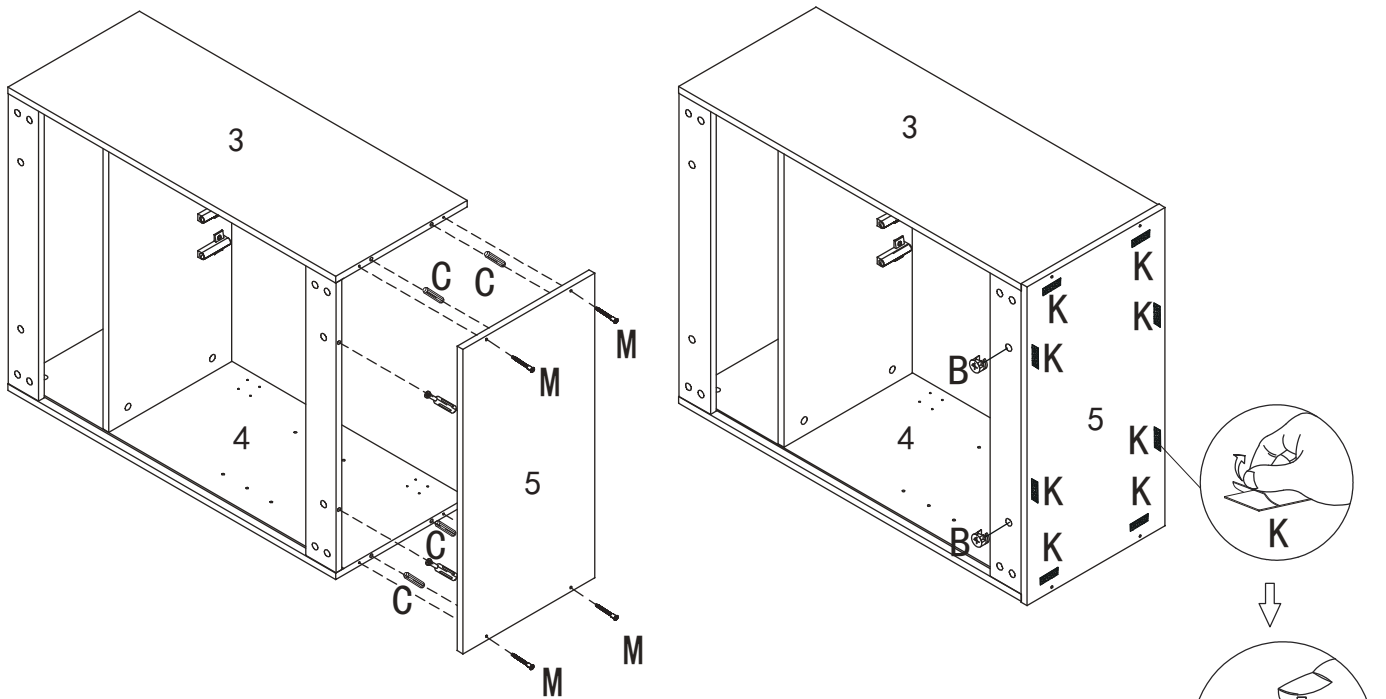

5.



M*4  Ø 5 x 40 mm	K*6 	B*2 	C*4  Ø 8 x 30 mm
--	---	---	--

6.

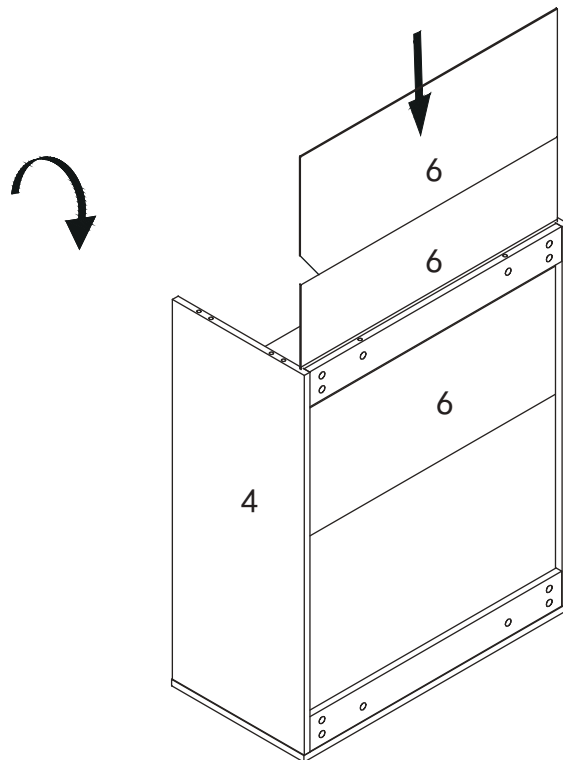

7.

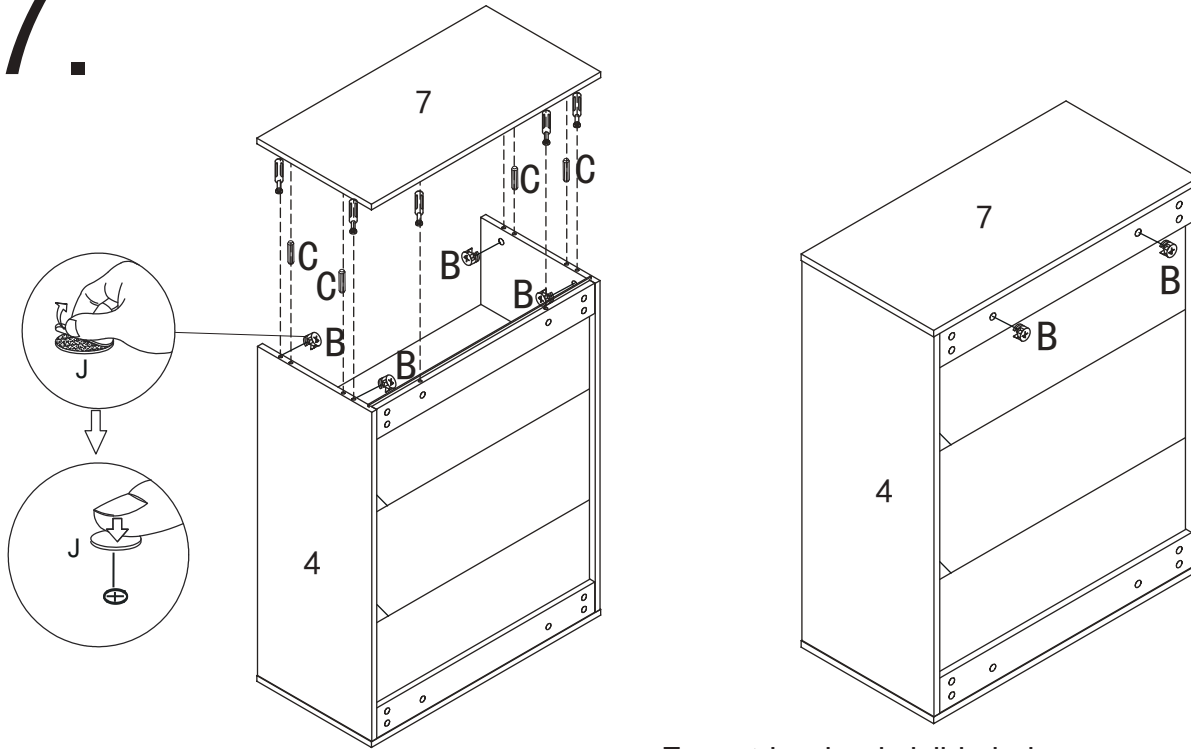

Eccentric wheel visible hole
sticker perfectly fits J

Exzentrisches Rad sichtbares
Loch perfekt geklebt mit J

Excentrique trou visible coller
parfaitement J

B*6



C*4



Ø8 x 30 mm

J*4



8.

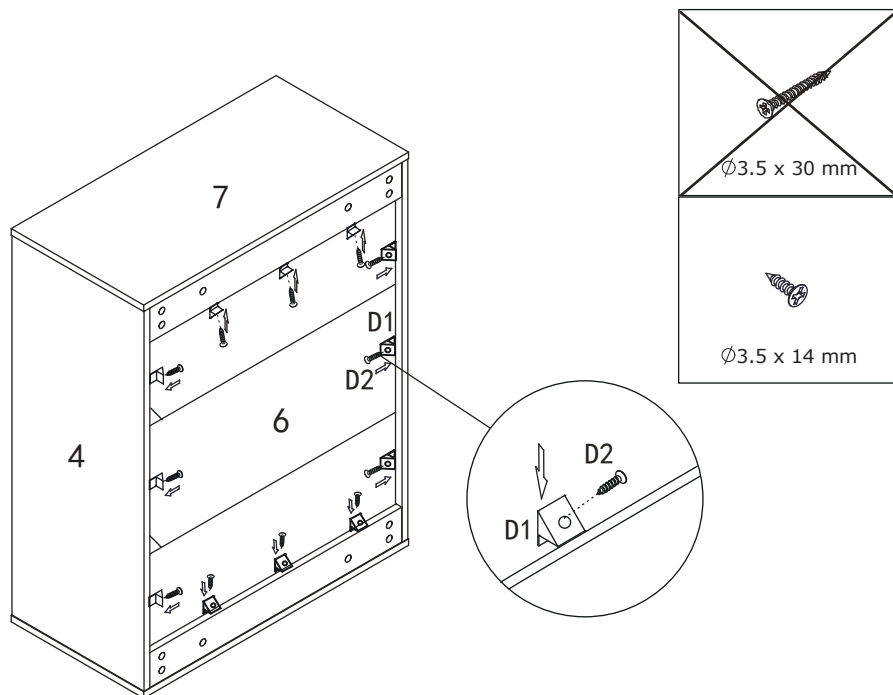

D1*12



D2*12



Ø3.5 x 14 mm

9.

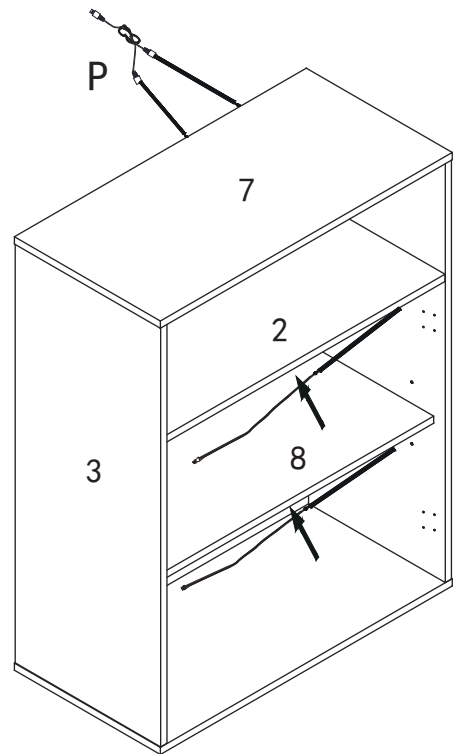
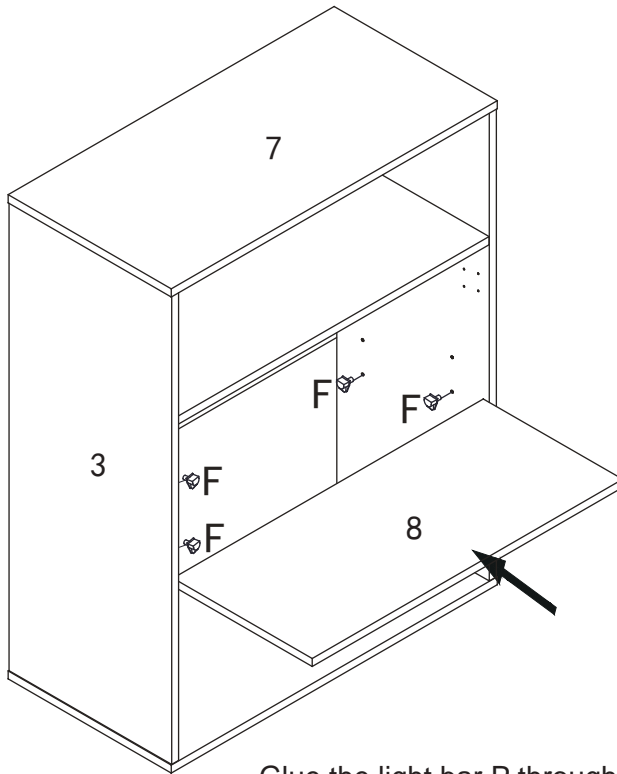

Glue the light bar P through the hole of the back plate 6 to the boards 2 and 8

F*4



P*1



Collez la barre lumineuse P à travers le trou de la plaque arrière 6 sur les planches 2 et 8

Kleben Sie den Lichtbalken P durch das Loch der Rückplatte 6 auf die Platinen 2 und 8

10.

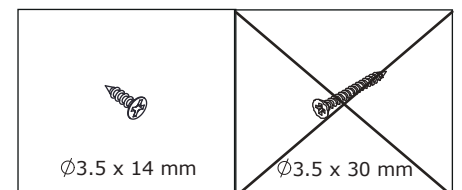
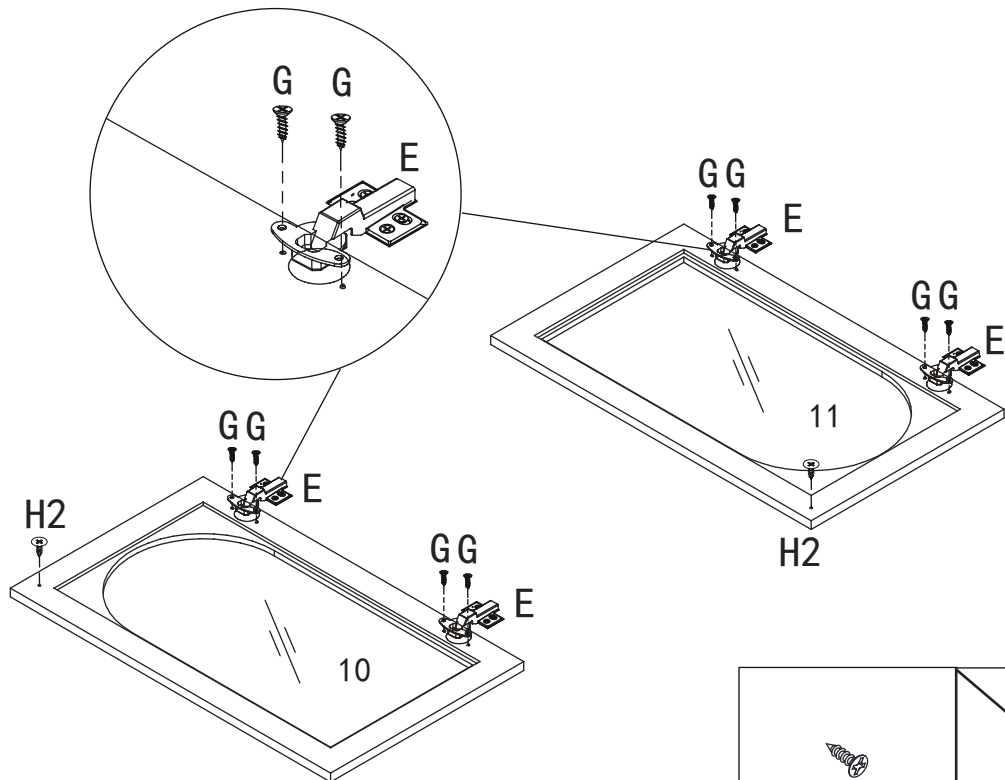

G*8



Ø3.5 x 14 mm

E*4



H-H2*2



11.

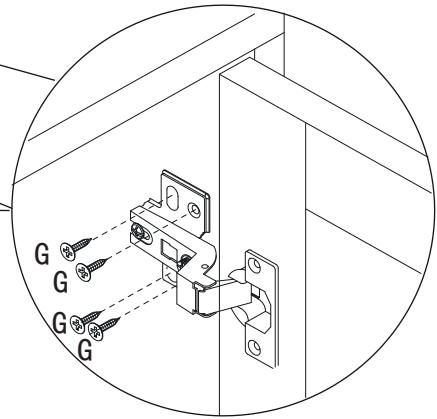
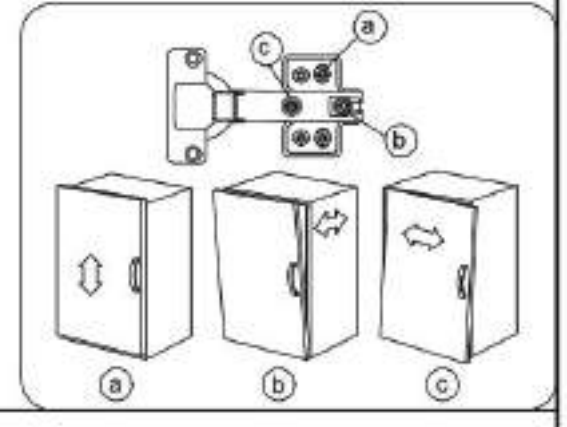
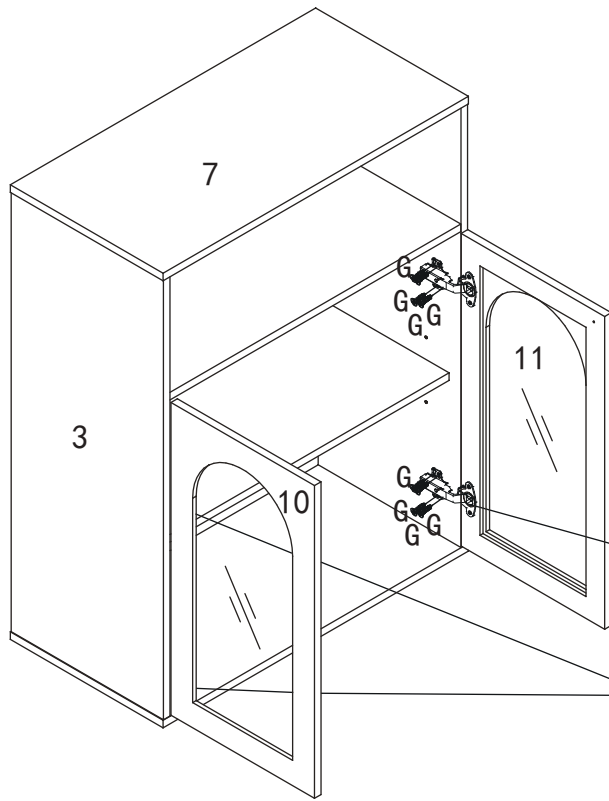
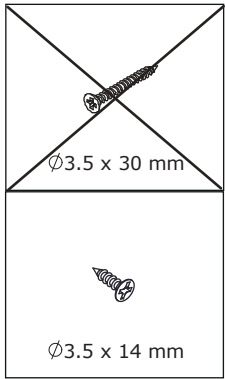

G*16



Ø3.5 x 14 mm

12.

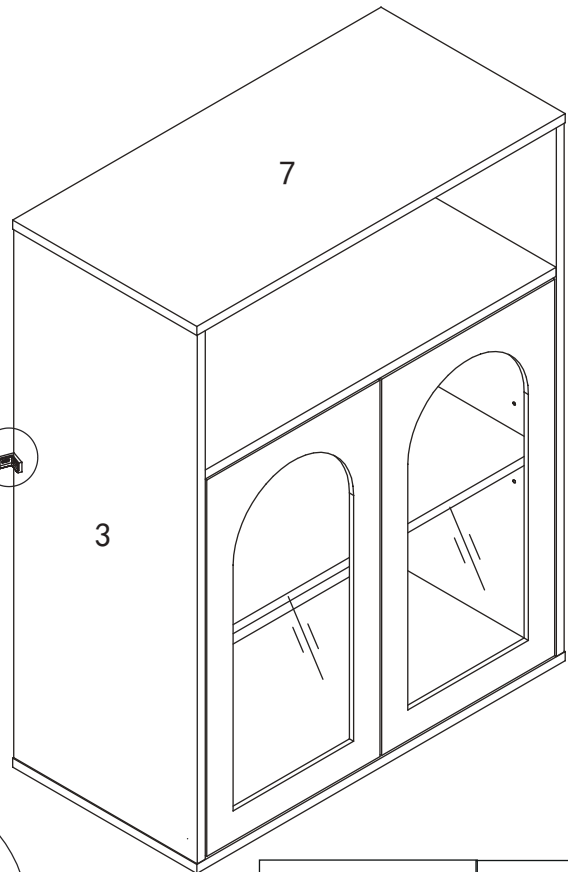
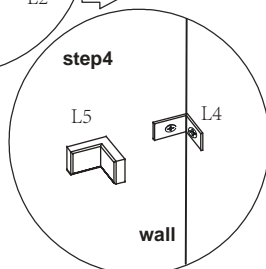
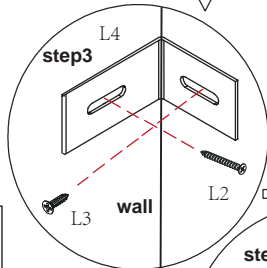
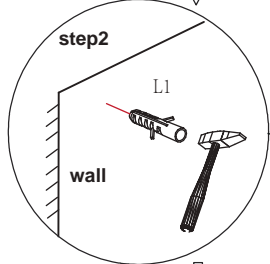
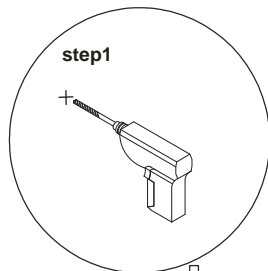

L4*2



L5*2



L1*2



L2*2



L3*2



Ø3.5 x 30 mm

Ø3.5 x 14 mm

Ø3.5 x 14 mm

Ø3.5 x 30 mm

14.

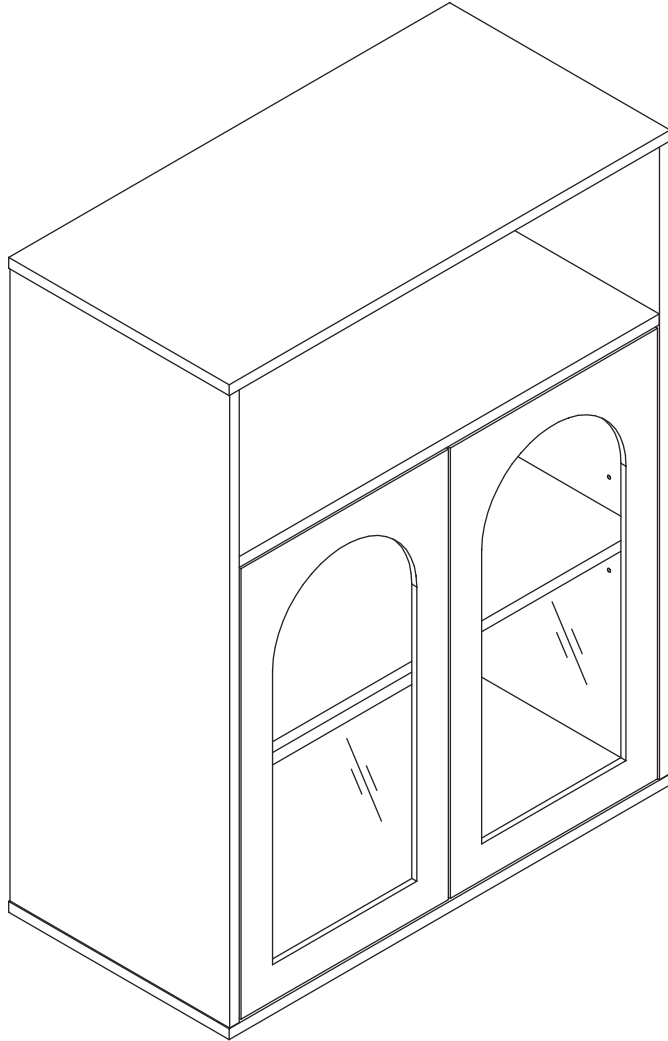

15.

Wenn Sie die Lichter nicht erfolgreich arbeiten lassen können, überprüfen Sie bitte die Folgendes:

1. Bitte überprüfen Sie die Fernbedienung. Sie müssen die Fernbedienung abreißen Plastikseptum vor Gebrauch.
2. Lassen Sie die Fernbedienung nicht zu weit vom Empfänger entfernt sein Es gibt kein Hindernis zwischen ihnen.
3. Bitte beachten Sie, dass die Fernbedienung für den Transport keine Batterien enthält. Das Batteriemodell lautet: CR2025

Si vous ne parvenez pas à faire fonctionner les lumières correctement, veuillez vérifier les points suivants•:

1. Veuillez vérifier la télécommande. Vous devez retirer le septum en plastique de la télécommande avant utilisation.
2. Ne laissez pas la télécommande être trop éloignée du récepteur. Il n'y a aucun obstacle entre eux.
3. Veuillez noter que la télécommande ne contient pas de piles pour le transport. Le modèle de batterie est•: CR2025

If you can't make the lights work successfully, please check the following:

1. Please check the remote control. You need to tear off the remote plastic septum before use.
2. Don't let the remote control be too far from the receiver There is no obstacle between them.
3. Please note that the remote control does not contain batteries for transportation. The battery model is: CR2025

16.

NOTE: The battery in the remote control requires you to purchase and install it yourself.
Model: CWG-5050RGB-60D-5V

①



②



③



④



⑤



⑥



Model: CWG-5050RGB-60D-5V

⑦



⑧



17.

CE

DECLARATION OF CONFORMITY

Manufacturer's Name: Hanron Lighting Co., Limited
Manufacturer's Address: 3/F, NO.1, Jintai Road, Second Industrial Park,
ShangwuCommunity, Shiyao, Bao'an District, Shenzhen,
Guangdong.518108.China
Representative: Johnson
Product: LED Strip Light
Model Number: HR00-A
Technical Data:Input: DC 24V

Product Image



DECLARATION

I declare that this declaration is issued under sole responsibility of Hanron Lighting Co., Limited and that the above referenced product is in conformity with the applicable requirements of the EU Directives: 2014/30/EU/2011/65/EU, and is CE-marked accordingly

Essential requirements:

Standards used to show compliance -CE-ROHS Directive
IEC 62321:2017
Reference to Report number.: HW20200819012R

Standards used to show compliance -EMC Directive

EN 55015:2013+A1:2015:
EN 61000-3-2:2014:EN 61000-3-3:2013:EN 61547:2009(EN
61000-4-2:2009,EN 61000-4-3:2006+A1:2008+A2:2010.EN
61000-4-4:2012.EN 61000-4-5:2014,EN 61000-4-6:2014,EN
61000-4-8:2010.EN 61000-4-11:2004)Reference to Report
number.:HW20200902023E

Signed for and on behalf of:  Liang Haiwei

Name:  Liang Haiwei

Function: Sales manager

Place and date of issue: DanwuShijie Town, Dongguan 20240620

 Liang Haiwei
Signature and Company Chop

