

R

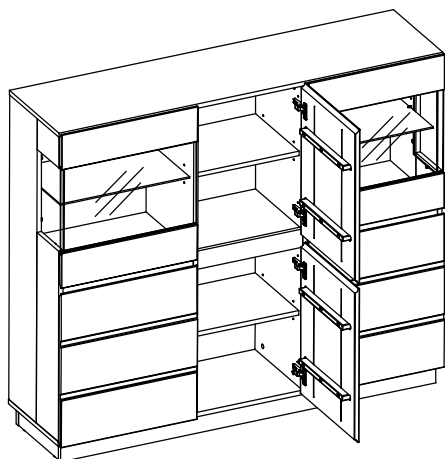

L

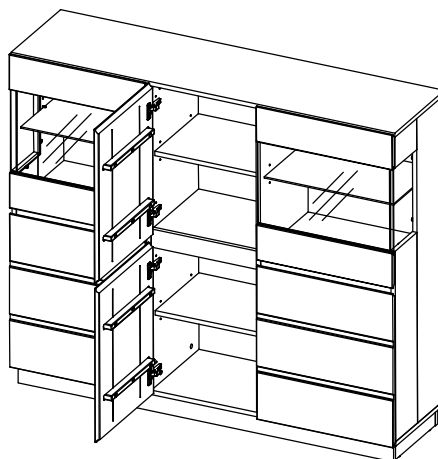

66921-1 66921-2

Service • Assistenza • Dienstverlening • Serwis  
 Servis • Szerviz • Сервисная служба

Name • Nom • Nome • Naam  
 Nazwa • Jméno • Název • Név  
 Denominare • Isim • Название

Nr • No • N° • Номер • Č • Sz

Typ • Type • Tip • Típus • Tipo  
 Тип

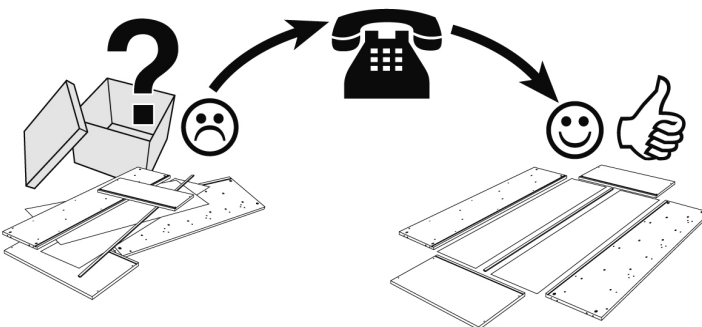
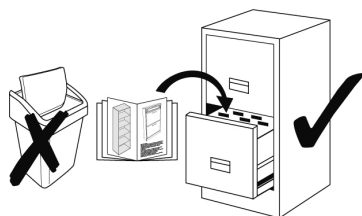

0  
10  
20  
30  
40  
50  
60  
70  
80  
90  
100  
110  
120  
130  
140  
150  
160

					H1		x34 ø 8x30	
H2		x10 ø 8x40	H3		x6 ø 8x50	D5		x62 ø 15x12,5
D59		x8 L=34/34	D117		x6 L=34/16/34	D2		x34 ø 5/11x34
D4		x44 ø 17	D116		x8	A97		x8 ø 2x15
D1		x16	D190		x4	D15		x4 ø 7/ø 5
G39		x8 ø 35	G40		x4 ø 35	A65		x24 ø 4x17
G33		x12	D31		x1	A10		x2 ø 4x16
D36		x12	H8		x1 ø 6x35	A69		x1 ø 4x60

66921-1 66921-2

Teil Nr. Pièces Nr. Pieces Nr. Часть Ном. Kawalek Nr. Parça No Kusù Nr. Kusov Nr. Pezzi Nr. Nr piесе. Darab száma. Stukken Nr. Kārtas Nr.	Anzahl Quantité Quantity Количество Ilość Miktar Množství Množstvo Quantità Cantitatea Mennyiség Hoeveelheid Skaitis	Kasten Nr. Colli Nr. Colli Nr. Коробка Ном. Polu Nr. Kutusu Nr. Kolonka Č. Počet balení Colli Nr. Nu pachete Colli száma. Colli Nr. Kastes Nr.	Maß, mm Dimensions, mm Dimensions, mm Размеры, mm Wymiary, mm Boyutlar, mm Rozměry, mm Rozmery, mm Dimensioni, mm Dimensiuni, mm Méterek, mm Afmetingen, mm Izmēri, mm	✓
03	1	1/3	688 x 160 x 16	
04	1	1/3	688 x 160 x 16	
05	1	1/3	112 x 160 x 16	
06	1	1/3	112 x 160 x 16	
07	1	1/3	1100 x 202 x 16	
08	1	1/3	1100 x 202 x 16	
12	2	2/3	1100 x 362 x 16	
24	1	1/3	1402 x 363 x 16	
25	1	1/3	1402 x 363 x 16	
33	2	2/3	476 x 331 x 16	
35	1	2/3	384 x 331 x 16	
37	2	2/3	475 x 320 x 16	
39	2	2/3	383 x 320 x 16	
42	1	2/3	384 x 66 x 16	
46	2	2/3	476 x 66 x 16	
50	3	1/3	292 x 66 x 16	
53	2	1/3	1370 x 66 x 16	
64	2	2/3	1109 x 485 x 3	
66	1	2/3	1109 x 393 x 3	
79	2	3/3	556 x 489 x 18	
80	2	3/3	498 x 556 x 18	
81	2	3/3	556 x 396 x 18	
103	2	3/3	320 x 170 x 4	
105	2	3/3	468 x 310 x 4	

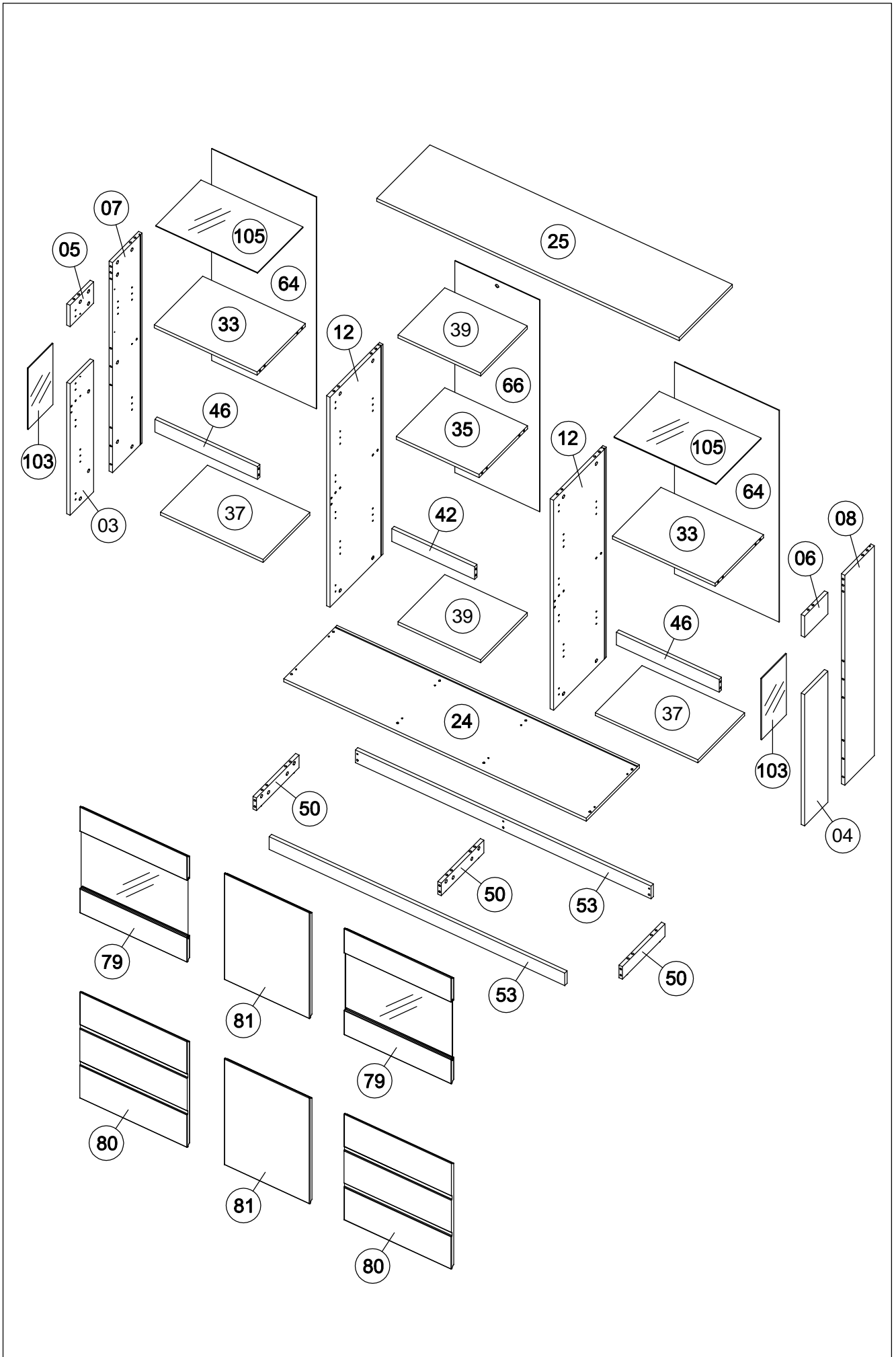

66921-1 66921-2



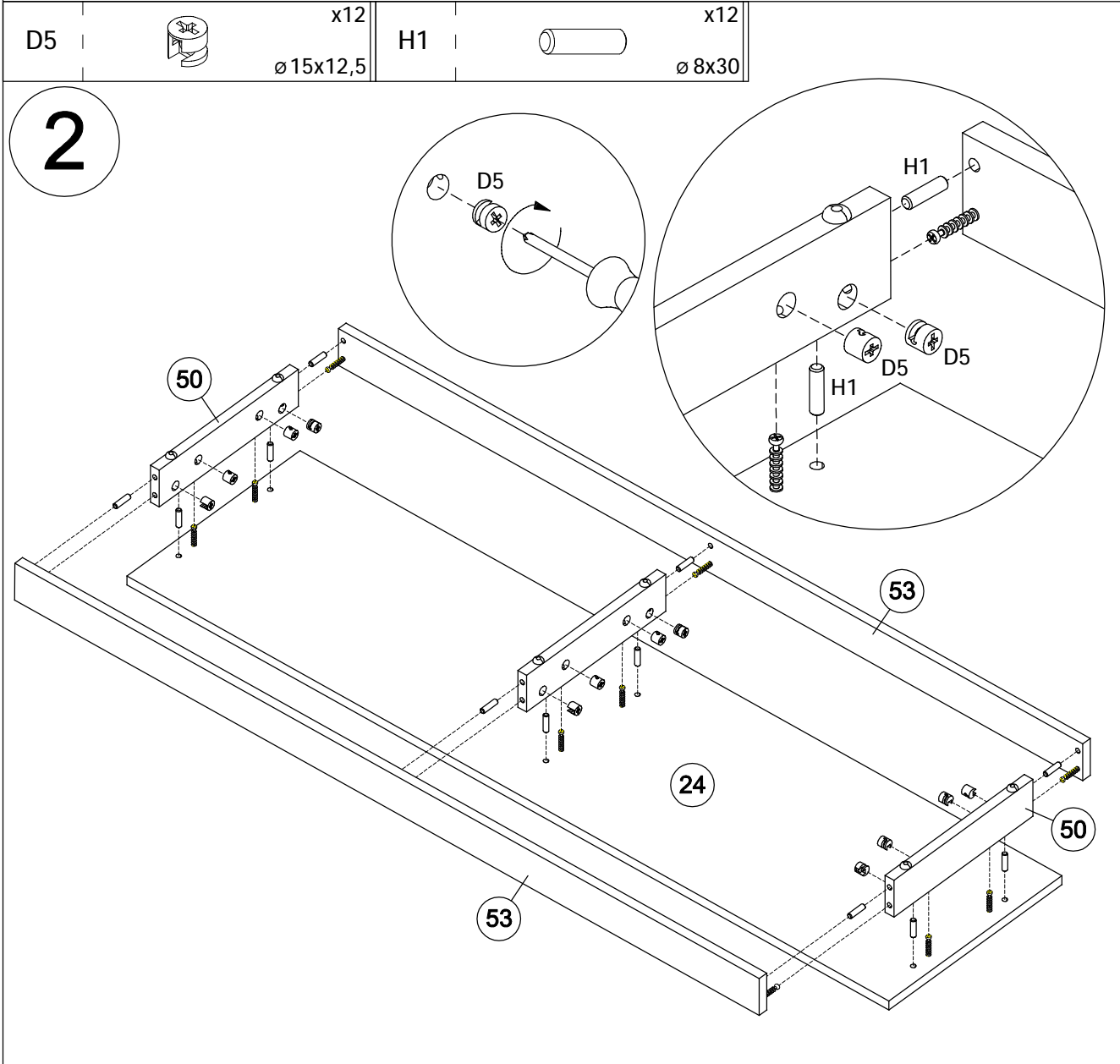
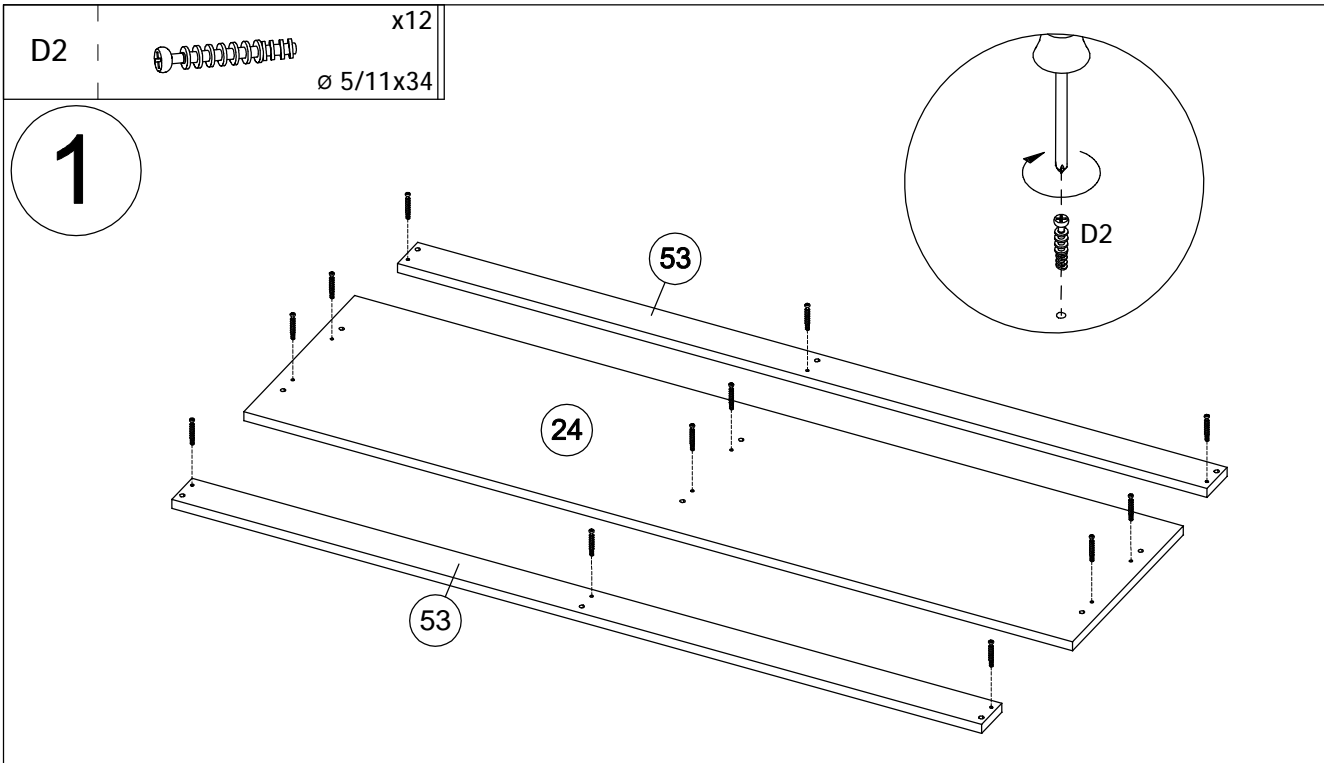

66921-1 66921-2

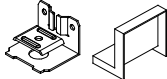

66921-1 66921-2

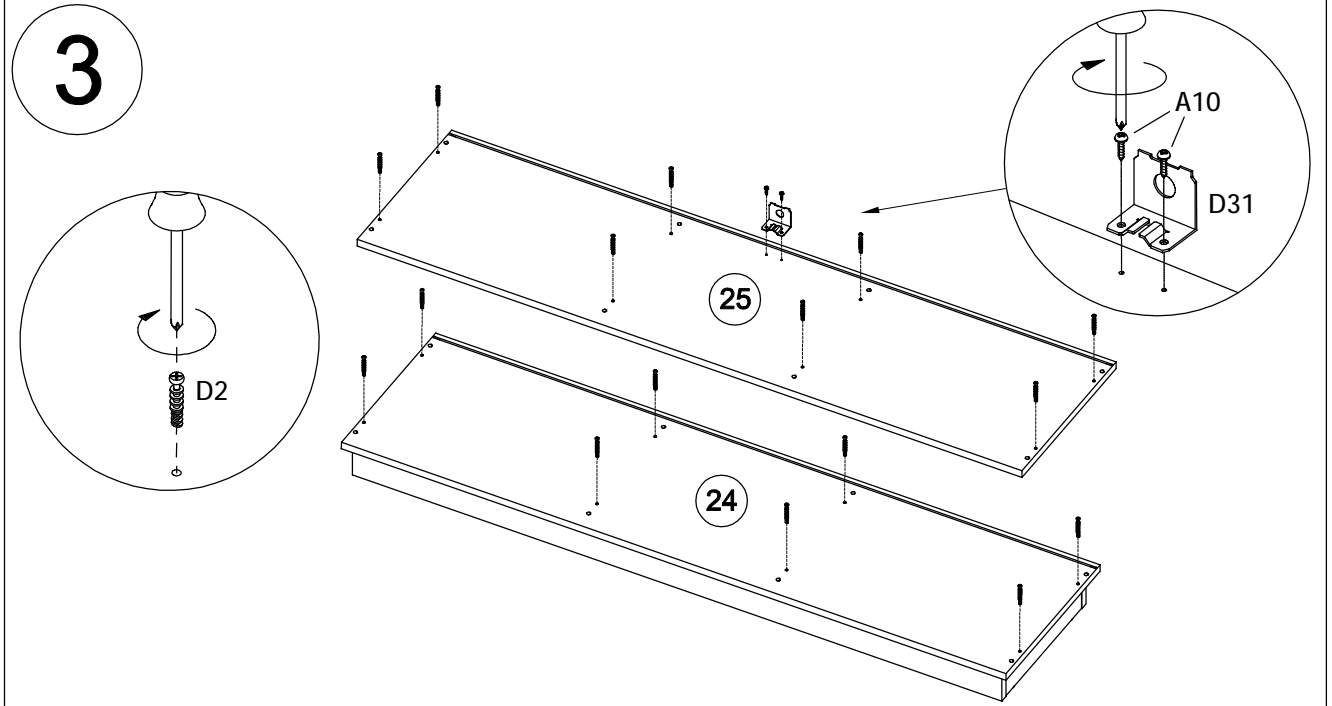
D2	 x16 ø 5/11x34	D31	 x1	A10	 x2 ø 4x16
----	--	-----	--	-----	--

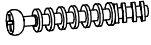

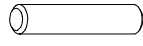
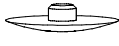
D2	 x6 ø 5/11x34	D59	 x8 L=34/34	D5	 x16 ø 15x12,5
H2	 x10 ø 8x40	D4	 x16 ø 17		

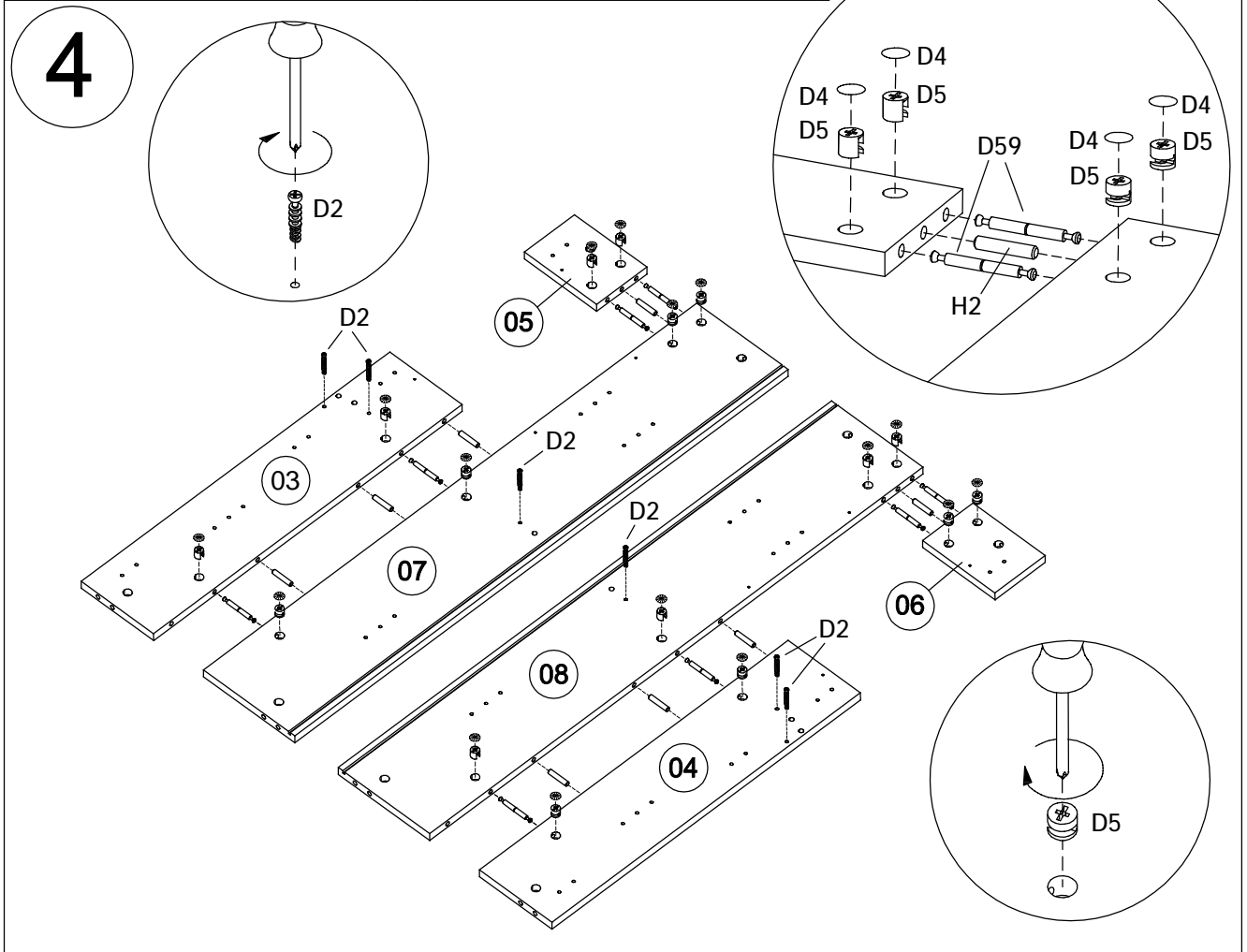

66921-1 66921-2

G33

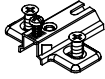

x12

5

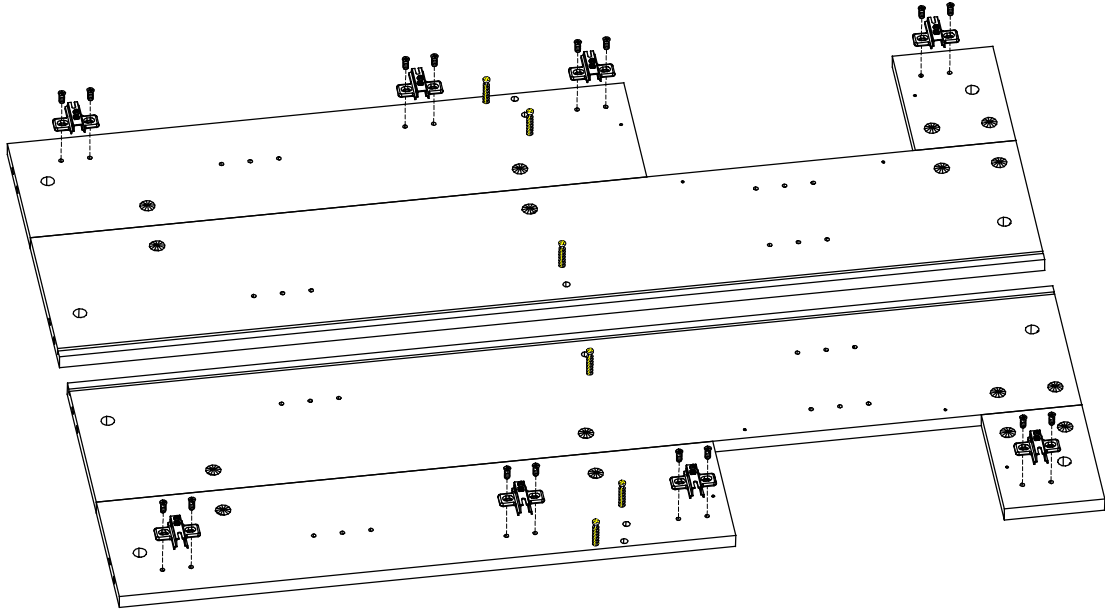
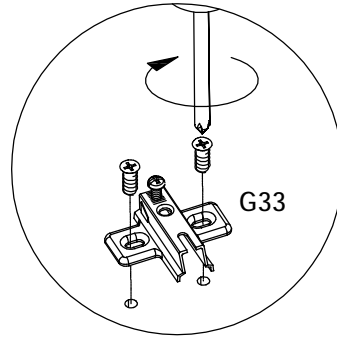

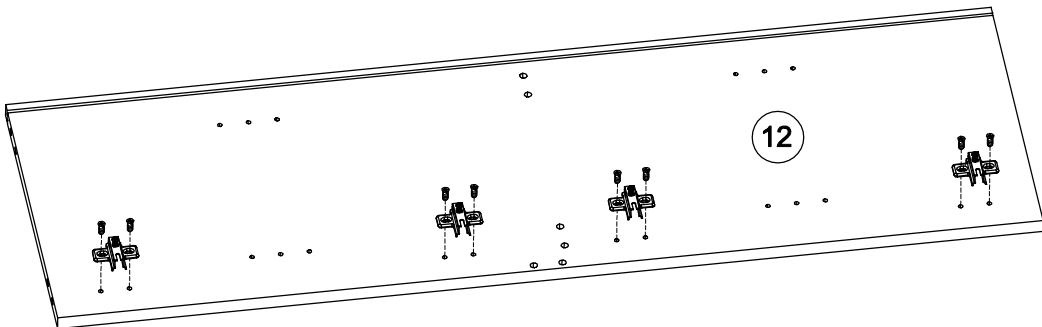

R

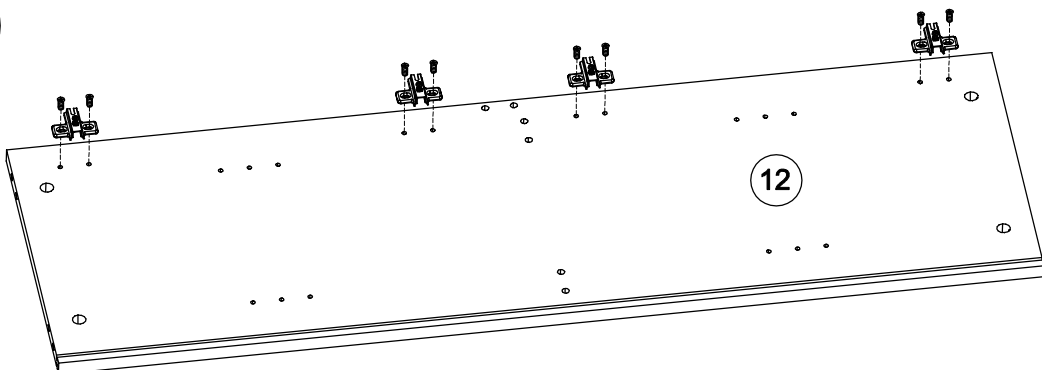

L

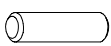
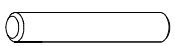
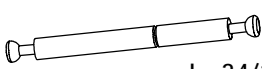

66921-1 66921-2

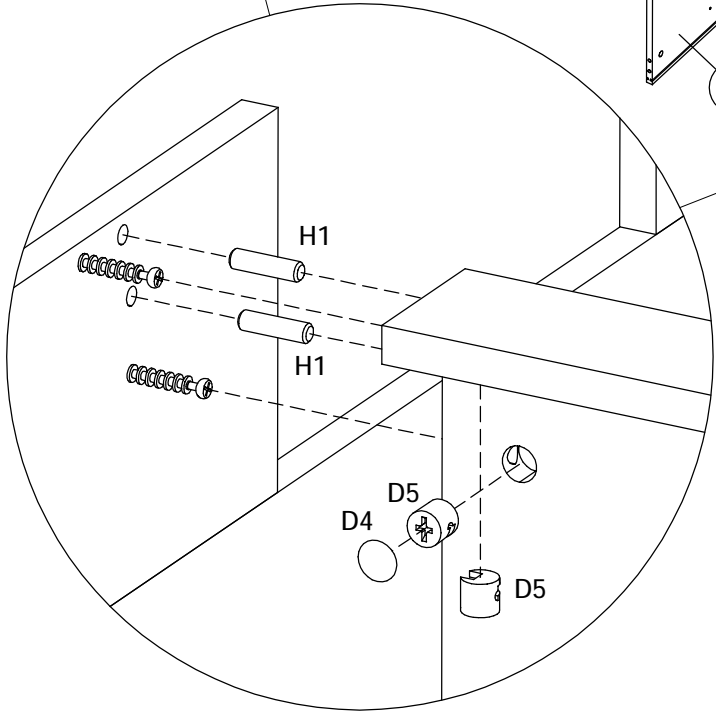
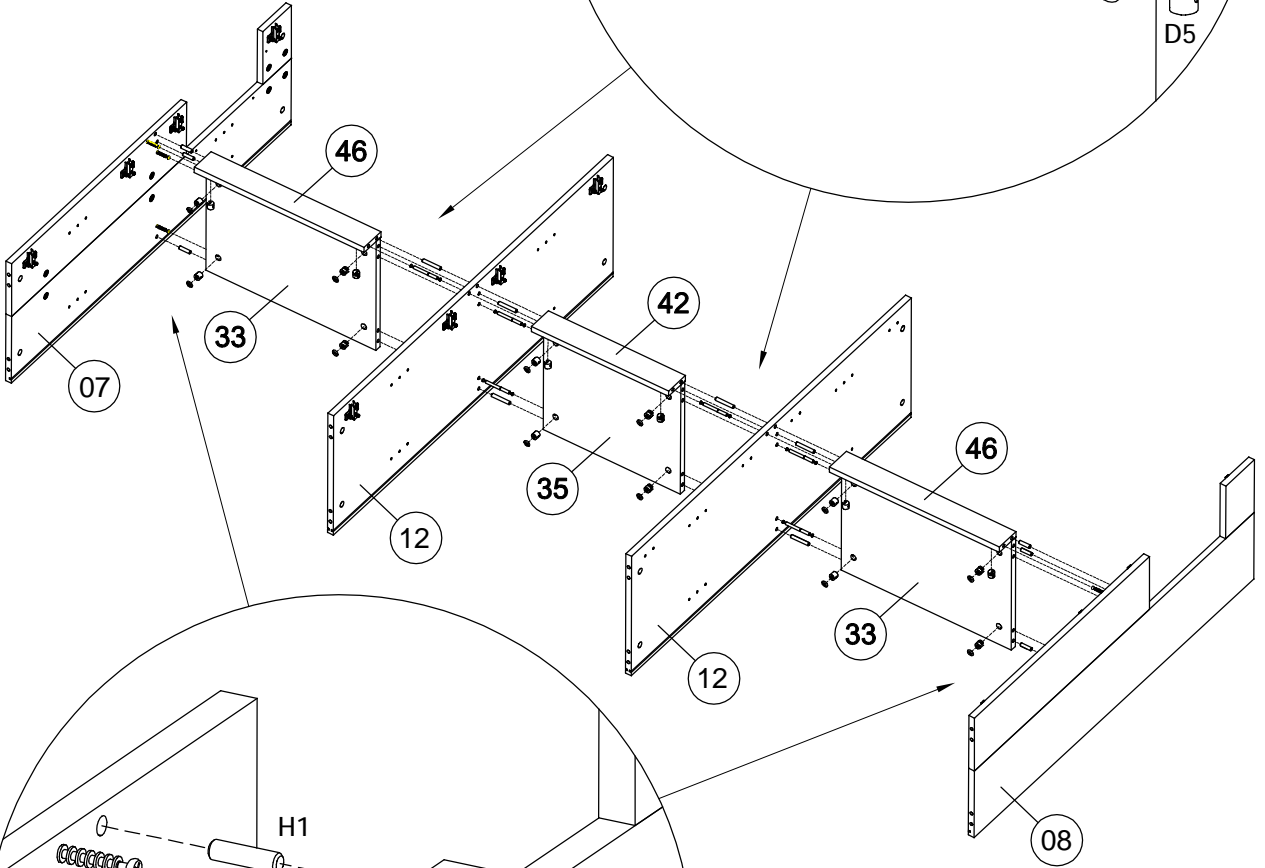
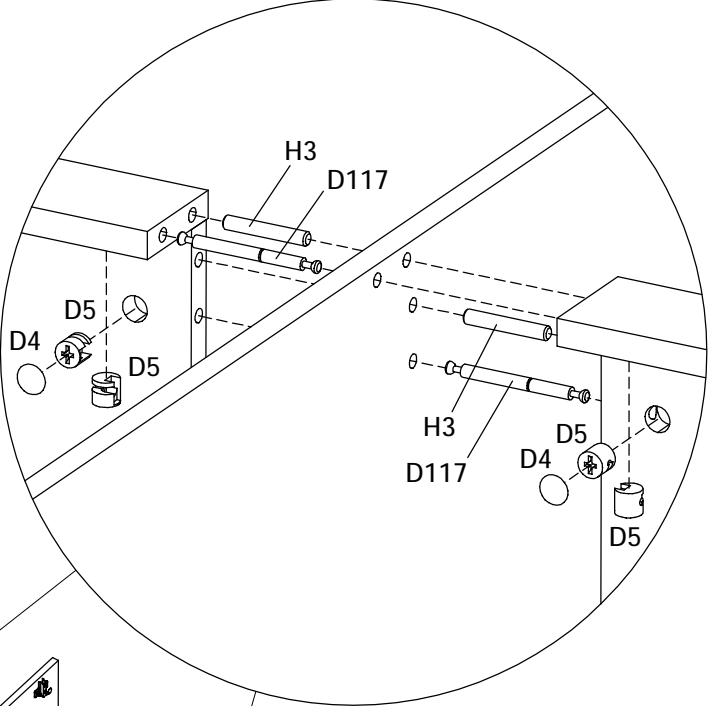
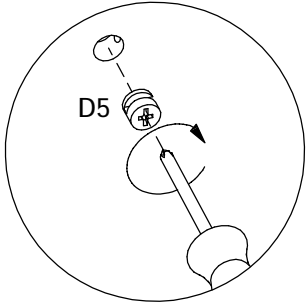

D5	 x18 ø15x12,5	H1	 x6 ø8x30	H3	 x6 ø8x50
D117	 x6 L=34/16/34	D4	 x12 ø17		

6



66921-1 66921-2



D5		x16 ø15x12,5	H1		x16 ø8x30	D4		x16 ø17
----	---	-----------------	----	---	--------------	----	---	------------

7

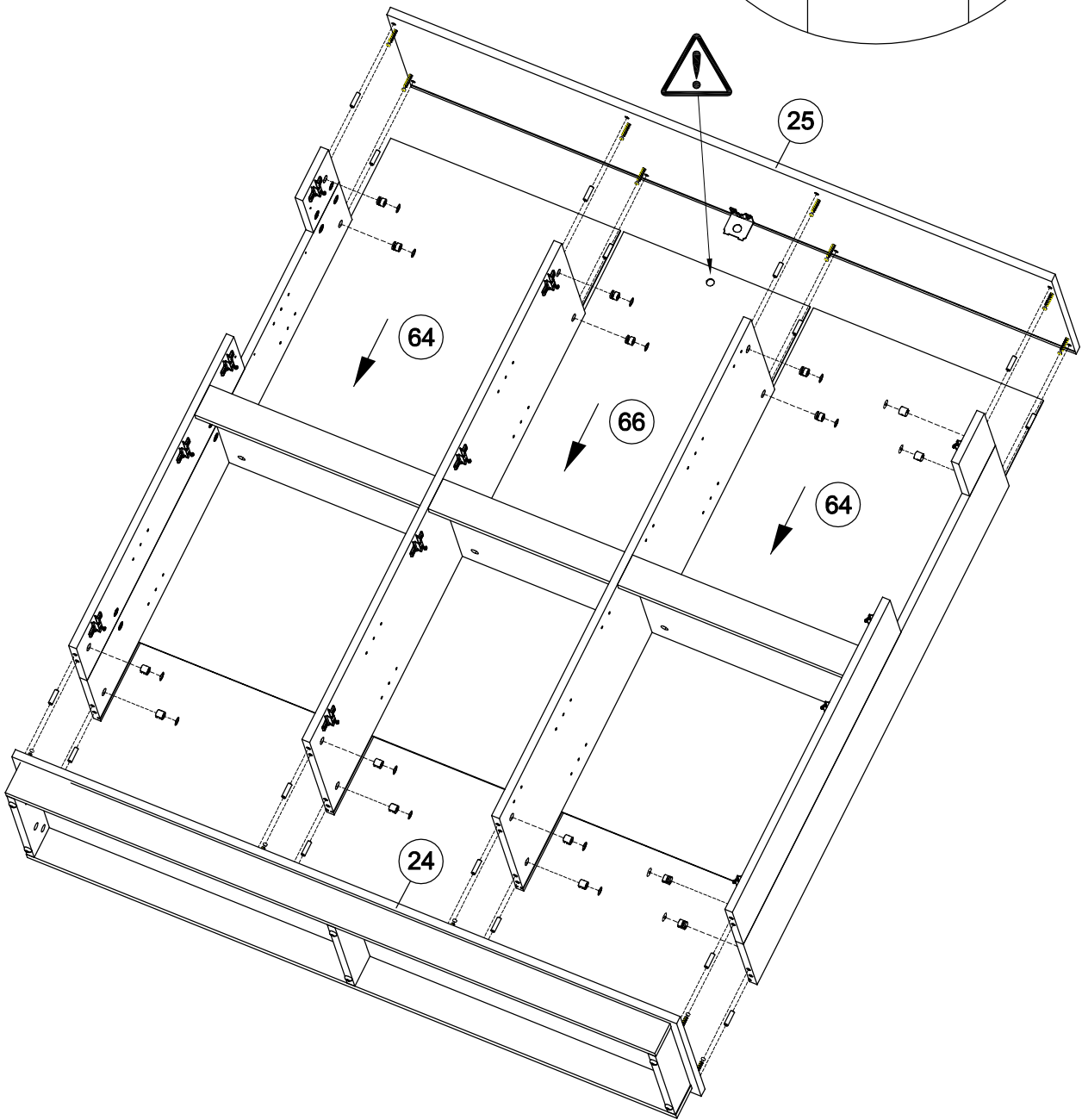
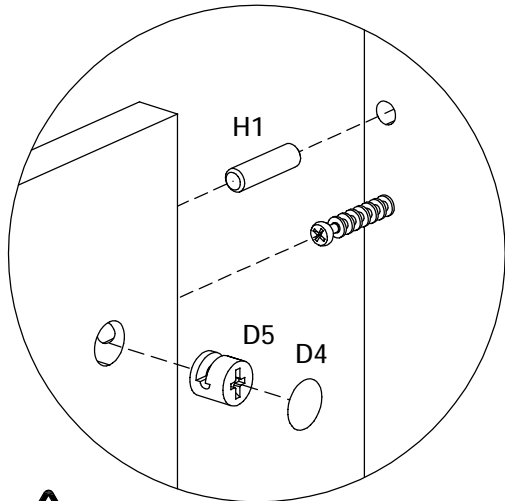
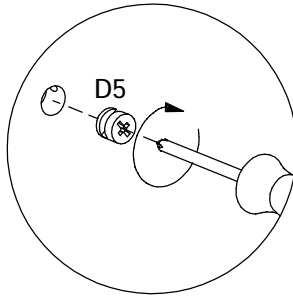



66921-1 66921-2

D36 |  x12

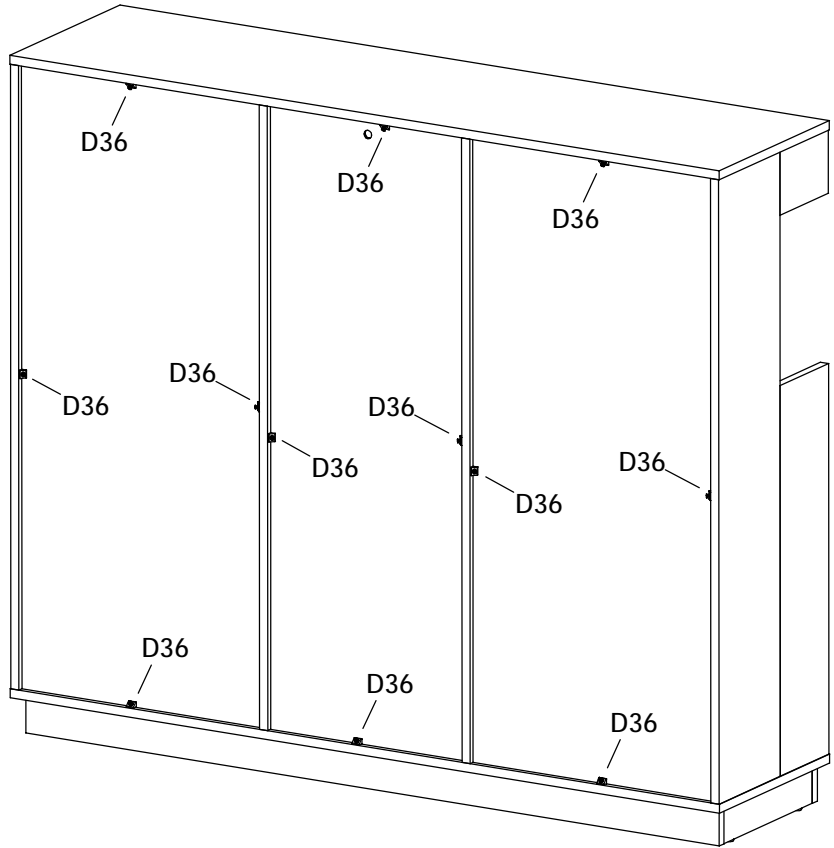
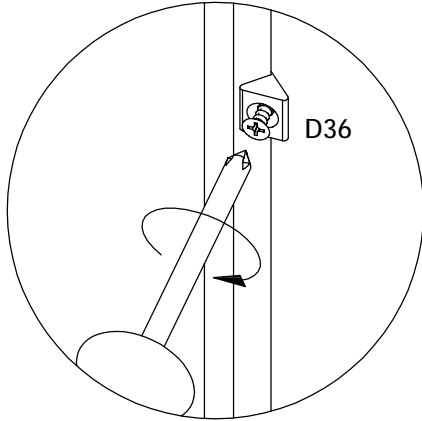
8



D31 |   x1

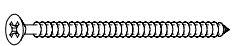

H8 |  x1  
ø 6x35

A69 |  x1  
ø 4x60

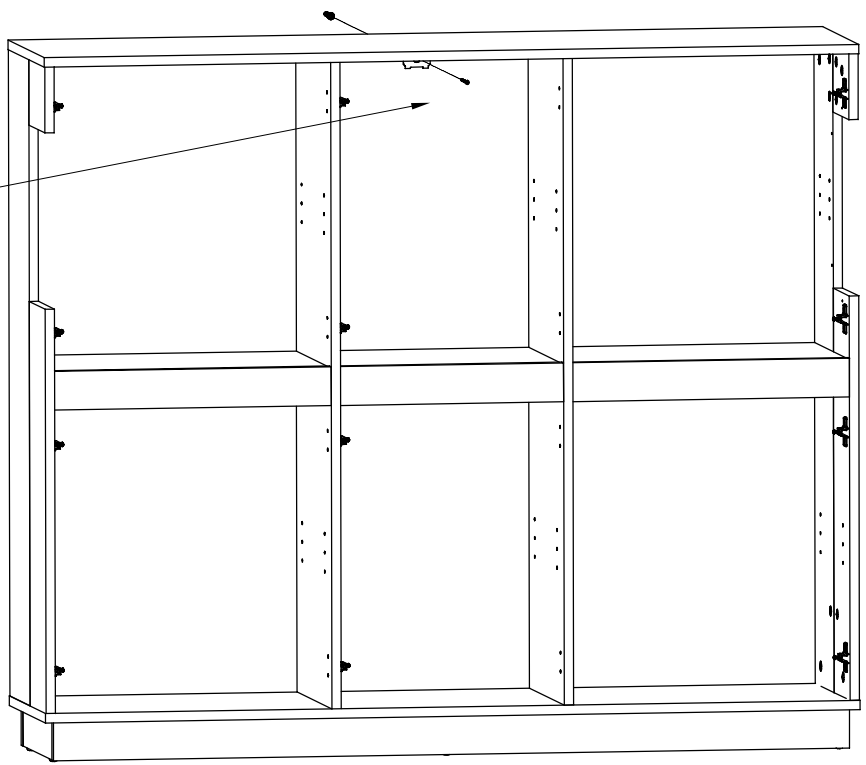
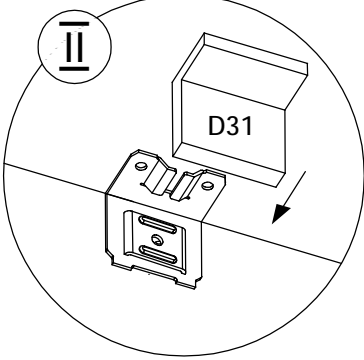
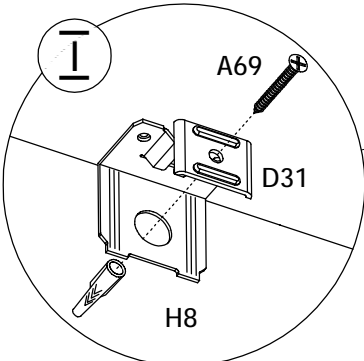
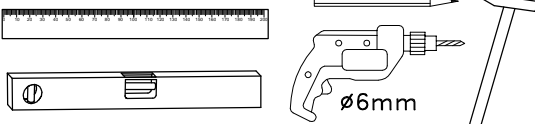
9





66921-1 66921-2

D116		x8	A97		x8
			ø 2x15		

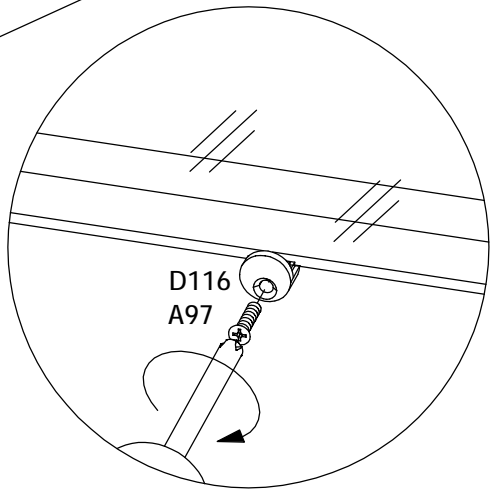
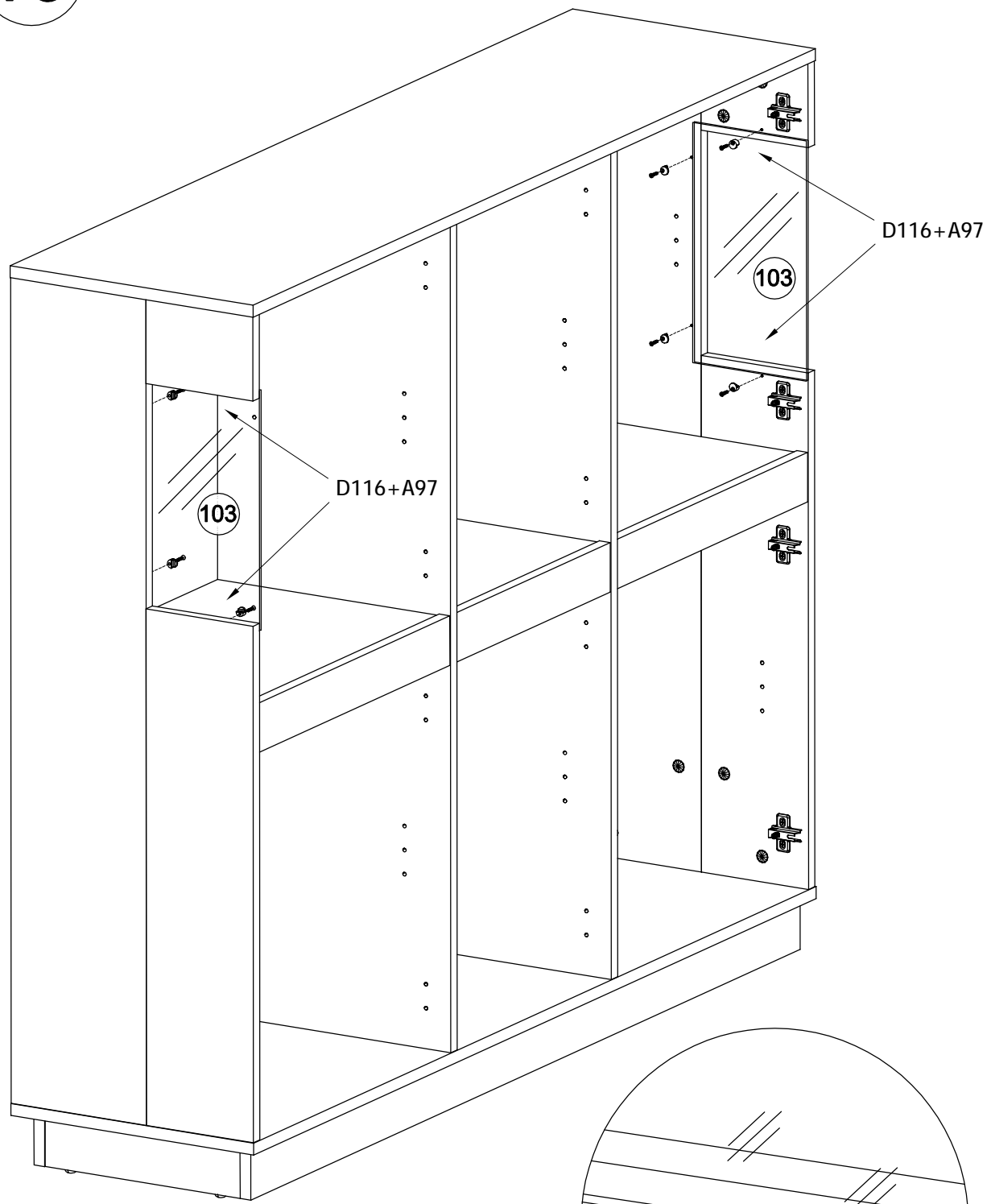
10



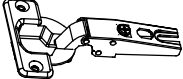

66921-1 66921-2

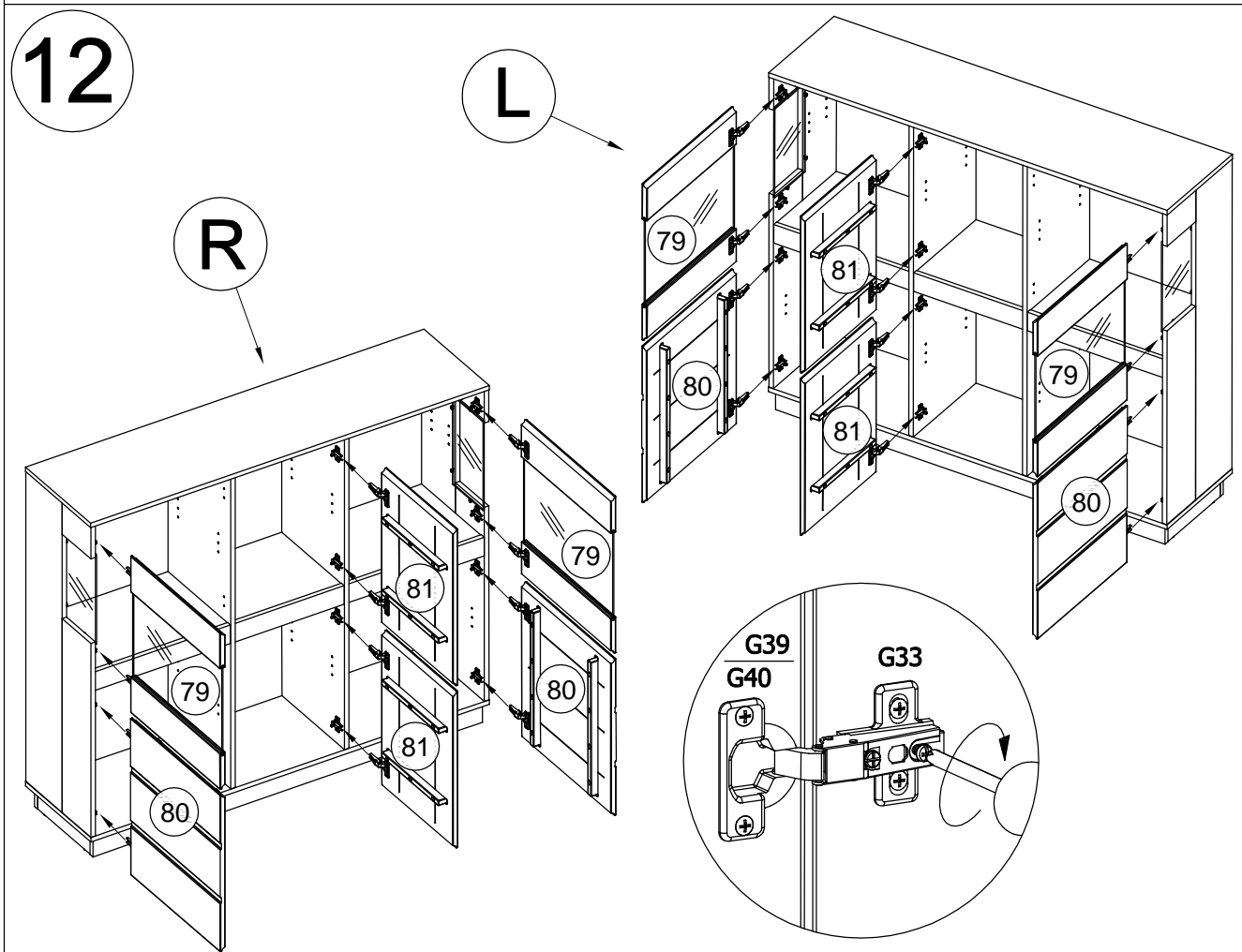
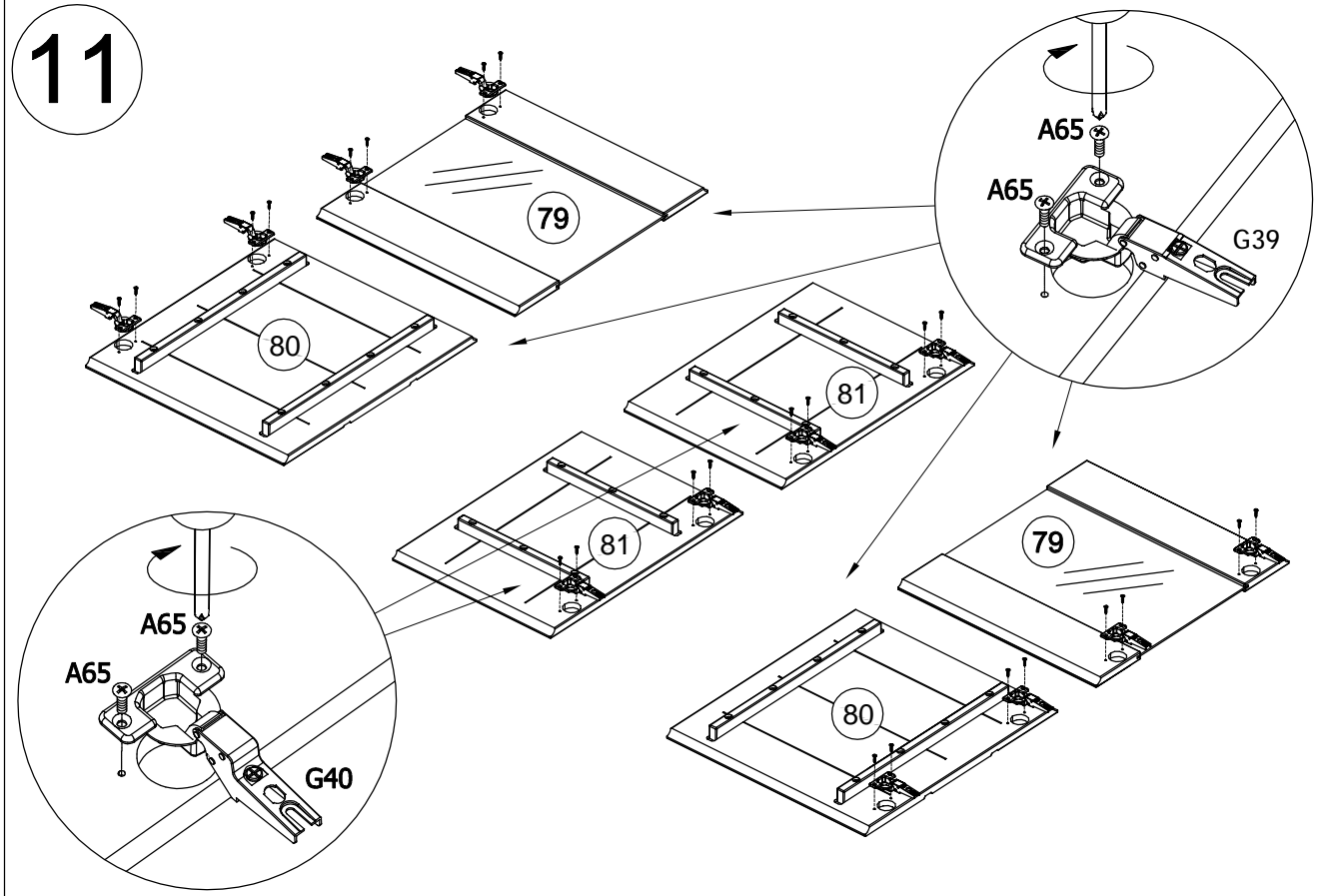
G39	 x8 ∅ 35	G40	 x4 ∅ 35	A65	 x24 ∅ 4x17
-----	--	-----	--	-----	---



66921-1 66921-2

D1		x16	D190		x4	D15		x4	$\varnothing 7/\varnothing 5$
----	---	-----	------	---	----	-----	---	----	-------------------------------

# 13

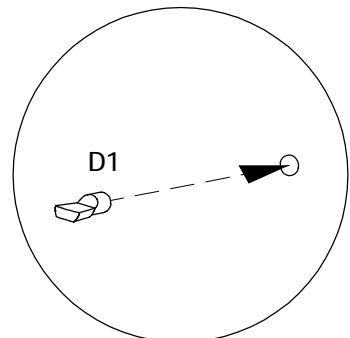
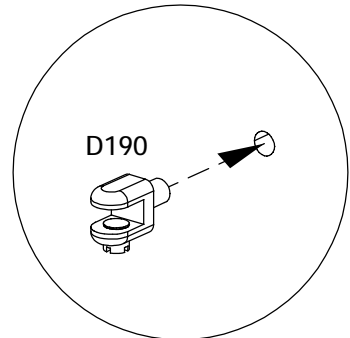
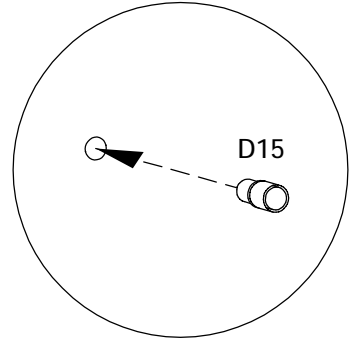
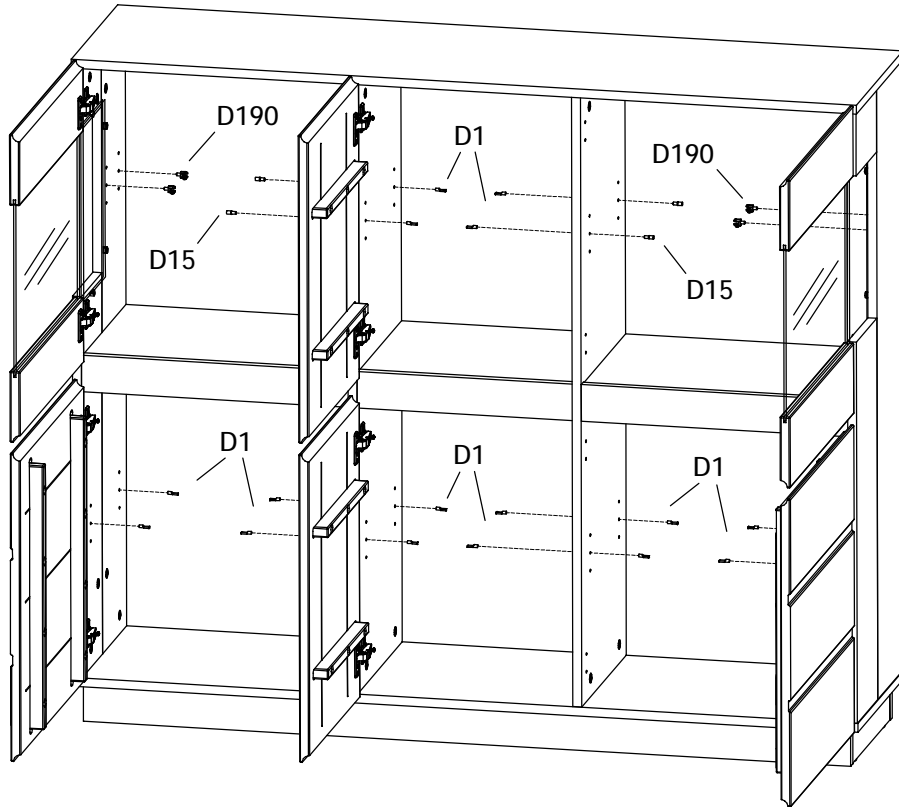

# 14

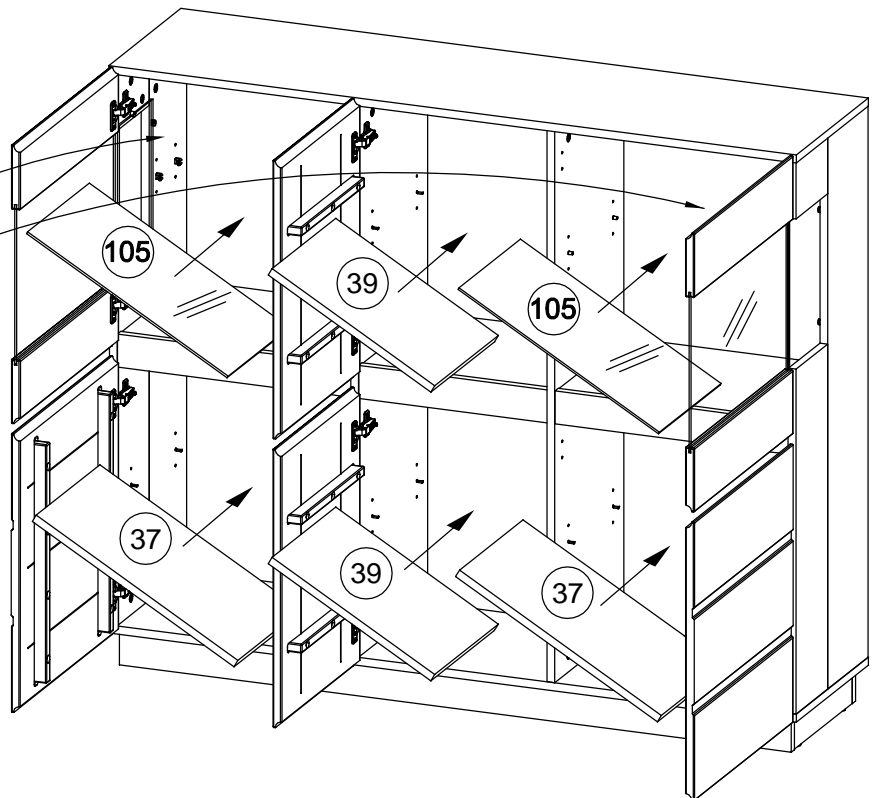
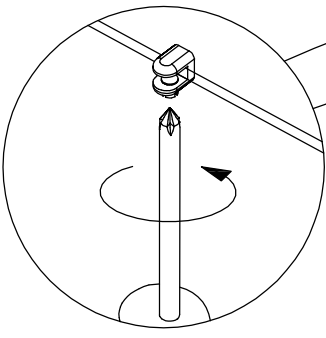

66921-1 66921-2

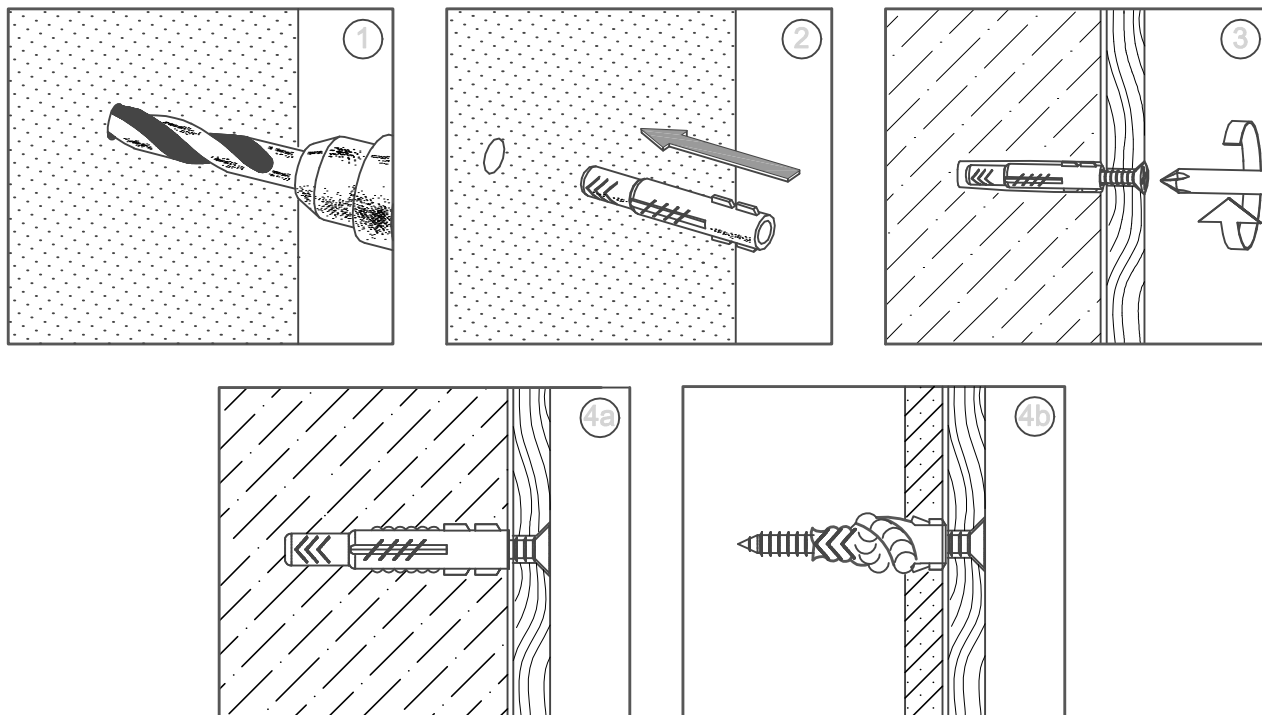
H8 A69   
ø4x60 ø6mm

- D** **Achtung:** Die Befestigung des Möbelstückes an der Wand muss von einer fachkundigen Person vorgenommen werden, da für die Montage an die Wand angepasste Dübel erforderlich sind.
- GB** **Attention:** A qualified professional is required when mounting furniture to the wall since dowels corresponding to the wall are required for this.
- FR** **Attention :** La fixation du meuble contre le mur doit être effectuée par une personne compétente car, pour le montage mural, il faut utiliser des chevilles adaptées.
- IT** **Attenzione:** Il fissaggio del mobile alla parete deve essere eseguito da persone esperte, dato che occorrono tasselli adeguati.
- NL** **Opgelet:** een vakkundige persoon dient het meubelstuk aan de muur te bevestigen; voor de montage aan de muur zijn immers aangepaste pluggen vereist.
- PL** **Uwaga:** Mocowanie mebla do ściany mogą przeprowadzić wyłącznie wykwalifikowane osoby, z uwagi na zastosowanie odpowiednio dopasowanych kołków do rodzaju ściany.
- CZ** **Pozor:** Montáž nábytku na stěnu musí provést odborník, protože k montáži na stěnu jsou zapotřebí upravené hmoždinky.
- SK** **Pozor:** Upevnenie nábytku na stenu musí vykonať odborník, nakoľko sú pre montáž na stenu potrebné vhodné hmoždinky.
- HU** **Figyelem:** A bútorelemek falra rögzítését szakembernek kell végeznie, mert a rögzítéshez megfelelő tiplit kell használni.
- RO** **Atenție:** Fixarea la perete a piesei de mobilier se realizează numai de către personal competent, deoarece montajul de perete necesită dibluri adecvate.
- TR** **Dikkat:** Mobilya parçasının duvara sabitlenmesi, duvar montajı için özel uyarlanmış dübeller gerektirdiğinden bu iş sadece bu konuda uzman bir kişi tarafından gerçekleştirilmelidir.
- RU** **Внимание:** Поскольку для монтажа на стене необходимо использовать специальные дюбели, мебель должна быть закреплена на стене квалифицированным персоналом.

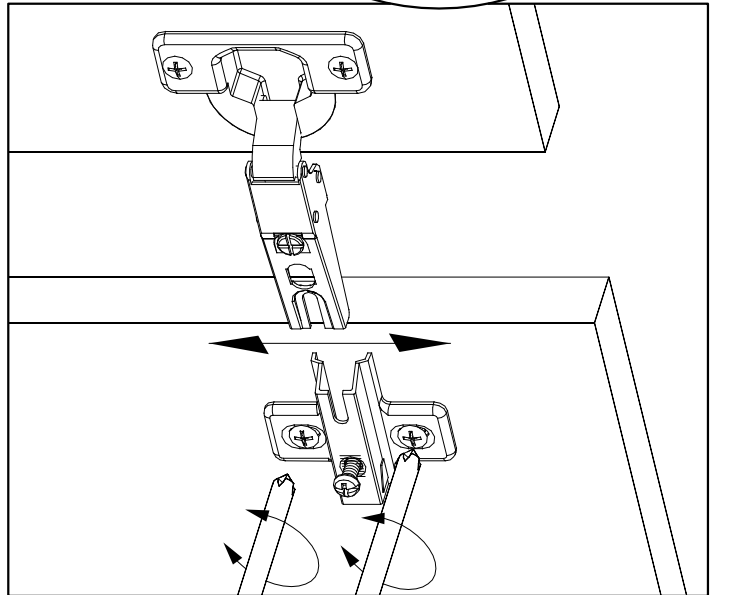
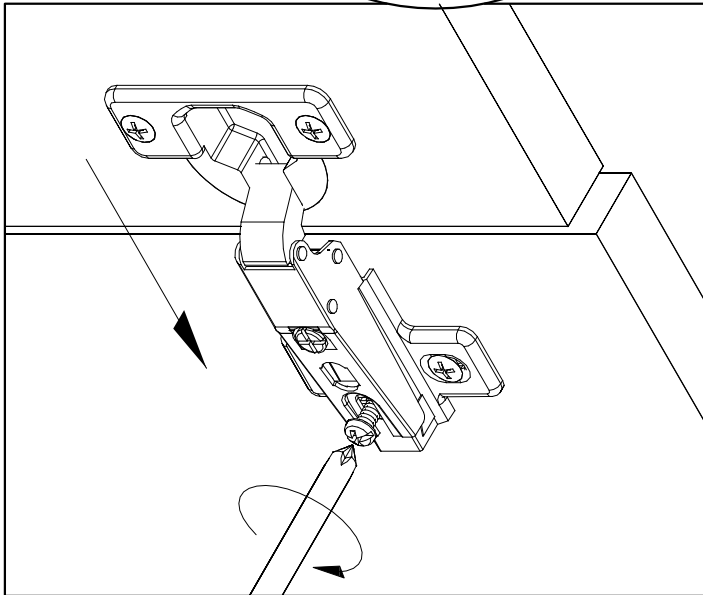
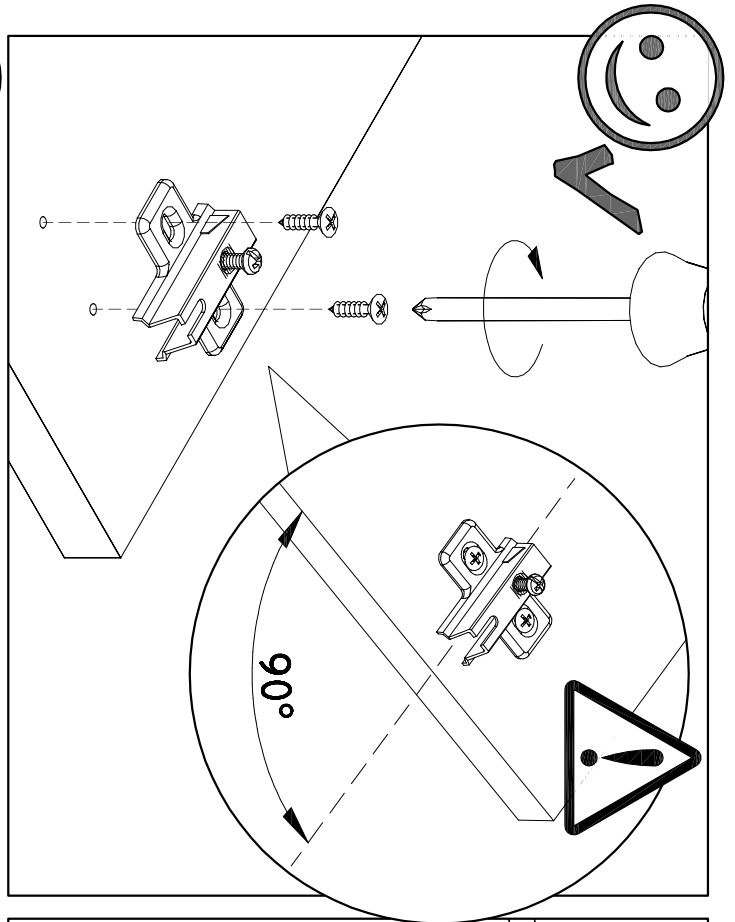
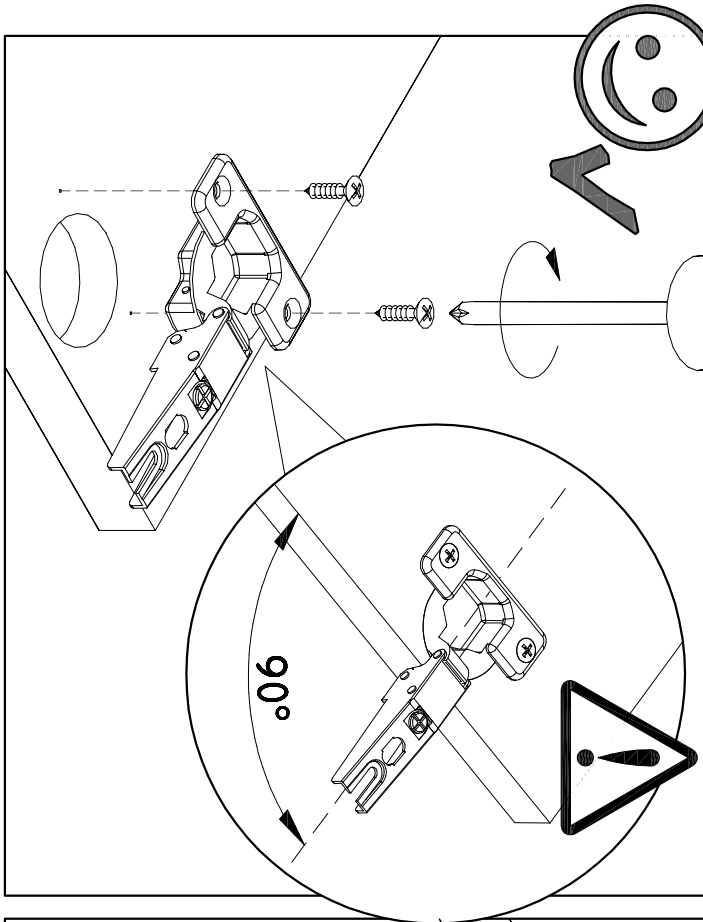
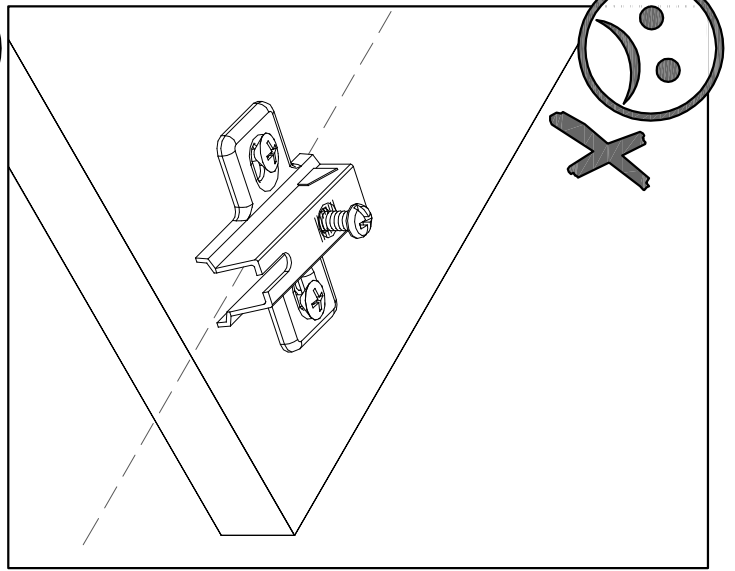
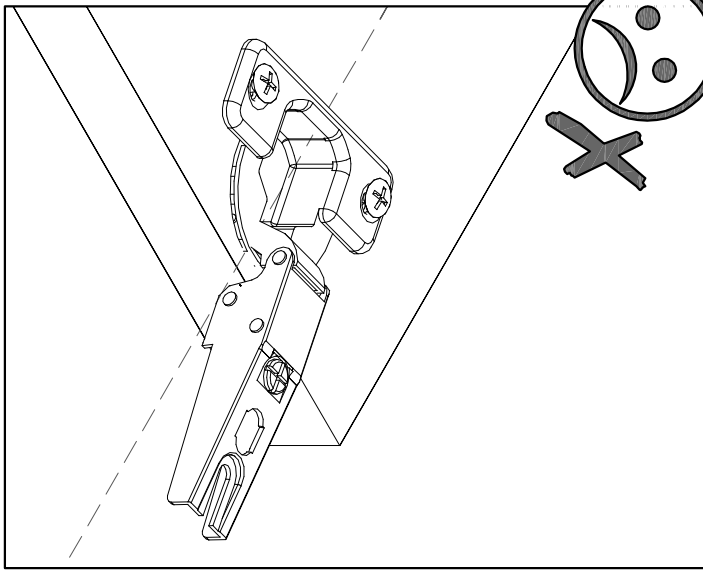

- (CZ) Úprava dveří  
 (D) Das Richten einer Türe  
 (F) Réglage d'une porte.  
 (HU) Beállítása egy ajtó  
 (I) Regolare una porta  
 (LV) Durvju regulēšana  
 (NL) Instellen van een deur  
 (PL) Regulacja drzwi  
 (RO) Reglarea o ușă  
 (RU) Регулировка двери  
 (SK) Úprava dverí  
 (TR) Bir kapı ayarlamama  
 (UK) Adjusting a door  
 (FIN) Oven säätö

