

75263

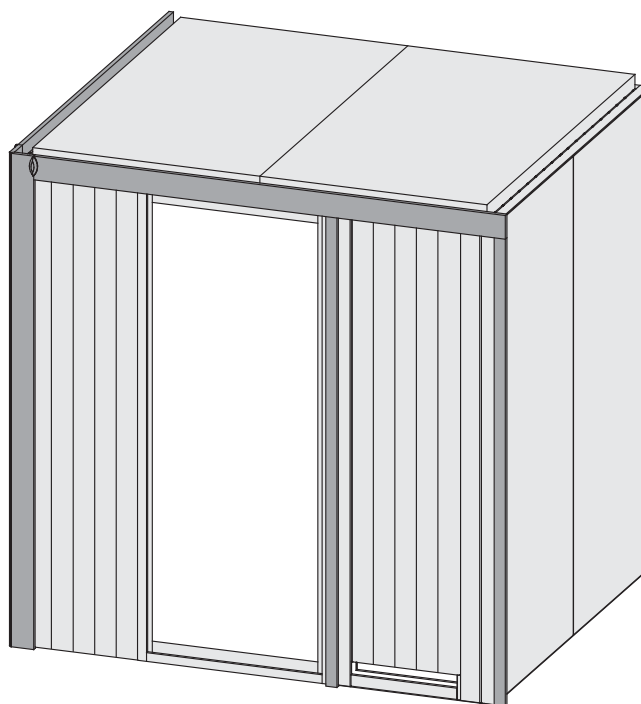

-  **Aufbauanleitung**
-  **Building Instructions**
-  **notice de montage**
-  **montagehandleiding**
-  **Montagevejledning**
-  **Instrucciones de construcción**
-  **Istruzioni per il montaggio**
-  **Montážní návod**

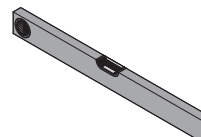

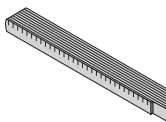
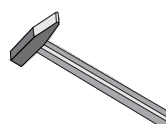
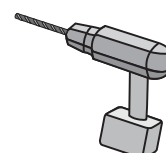
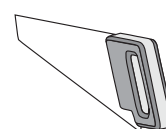

Vergleichen Sie zuerst die Materialliste mit Ihrem Paketinhalt! Bitte haben Sie Verständnis, dass Beanstandungen nur im nicht aufgebauten Zustand bearbeitet werden können!



En primer lugar, compare la lista de material con el contenido del paquete. Rogamos entienda que las reclamaciones sólo pueden ser tramitadas antes de montar el objeto!



Nejprve přezkontrolujte obsah balení podle materiálového listu! Mějte pochopení pro to, že případnou reklamaci se můžeme zabývat pouze tehdy, když díly nebudou smontované! Za pomoci tohoto seznamu můžete jednotlivé díly přiřadit k montážnímu návodu.



Vergelijk eerst de lijst van materialen met de inhoud van uw pakket! Reclamaties kunnen alleen in behandeling worden genomen zolang de onderdelen nog niet zijn gemonteerd!



First compare the list of materials with your package contents! Please understand that complaints can be processed in the non-built status only!



Commencez par comparer la liste du matériel avec le contenu de votre paquet! Sachez que nous traitons uniquement les réclamations concernant le matériel à l'état non monté!



Confrontate questa distinta materiali prima con il contenuto del pacchetto! Vi preghiamo di comprendere che eventuali reclami possono essere accolti solo prima del montaggio!

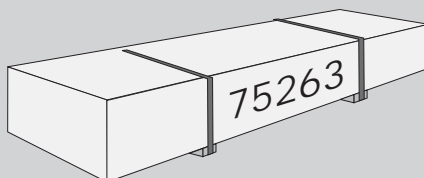

1 x W1	1920 x 433 x 68mm	ID 25547
2 x W2	1920 x 780 x 68mm	ID 25549

1 x W3	1920 x 606 x 68mm	ID 25550

2 x W4	1920 x 606 x 57mm	ID 23624
2 x W5	1920 x 780 x 57mm	ID 23625

1 x W6	1920 x 606 x 57mm	ID 23629

	Siehe Türpaket	
	Opmerking Door Package	
	Note Door Package	
	Remarque Package porte	
	Nota Paquete Puerta	
	Nota Door Package	
	Poznámka Door balíček	
1 x W7		

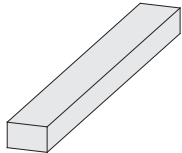

5 x B1	1920 x 19 x 3mm	ID 20799
4 x B2	750 x 36 x 12mm	ID 24239
4 x B3	1920 x 36 x 12mm	ID 24846
3 x B4	1884 x 45 x 17mm	ID 48037
4 x B5	70 x 45 x 18mm	ID 26366
4 x B6	800 x 45 x 18mm	ID 24796
4 x B7	480 x 95 x 18mm	ID 20930
4 x B8	580 x 95 x 18mm	ID 16708
2 x B9	1895 x 95 x 18mm	ID 39324
1 x B10	300 x 120 x 18mm	ID 22467
2 x B11	590 x 42 x 28mm	ID 26360
2 x B12	1130 x 42 x 28mm	ID 26361
2 x B13	1555 x 42 x 28mm	ID 24130
4 x B14	1666 x 42 x 28mm	ID 26377
2 x B15	1756 x 42 x 28mm	ID 24131
4 x B16	1841 x 42 x 28mm	ID 26376
3 x B17	1874 x 52 x 52mm	ID 26165

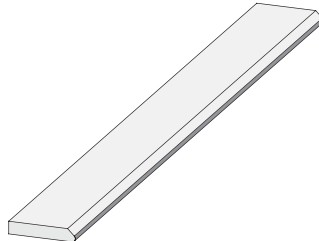

2 x G1	1980 x 95 x 17mm	ID 48540
--------	------------------	----------

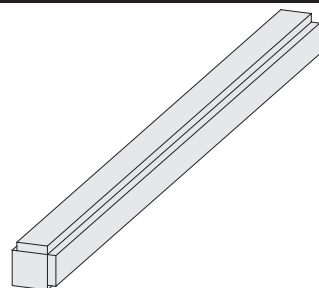

1 x K1	1874 x 64 x 64mm	ID 24725
--------	------------------	----------

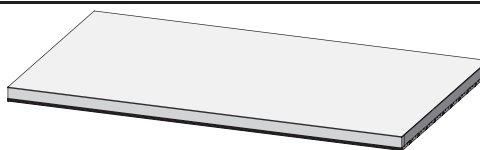

2 x M1	1582 x 918 x 57mm	ID 24795
--------	-------------------	----------

1 x

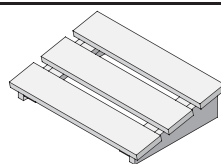

ID 20708

10m

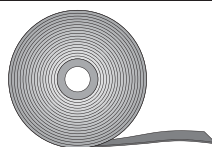

ID 14025



20 x	4,5 x 30mm	ID 26115
120 x	4,5 x 40mm	ID 26285



190 x	4 x 30mm	ID 3686
30 x	4 x 40mm	ID 21925
80 x	4 x 50mm	ID 3688
50 x	4 x 70mm	ID 3689
80 x	4,5 x 80mm	ID 9204
40 x	6 x 60mm	ID 14014

6 x S1



ID 14266



150 x S2	4,5 x 30mm	ID 26116
16 x S3	12 x 18mm	ID 46403

4 x T1

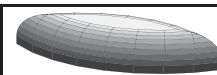

ID 26272

20 x



ID 14005



5 x	3 x 16mm	ID 46376
-----	----------	----------

1 x

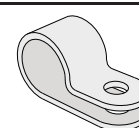

ID 50420

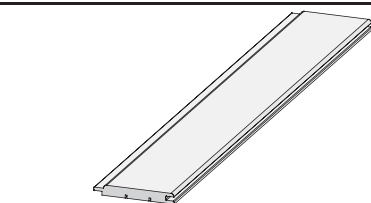

2 x E1	1920 x 97 x 12mm	ID 22863
--------	------------------	----------

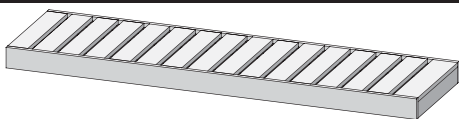

2 x L1	1810 x 550 x 90mm	ID 21767
--------	-------------------	----------

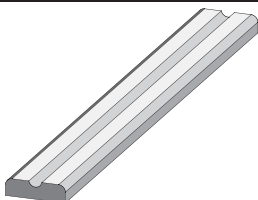

2 x F1	1810 x 90 x 22mm	ID 26112
--------	------------------	----------

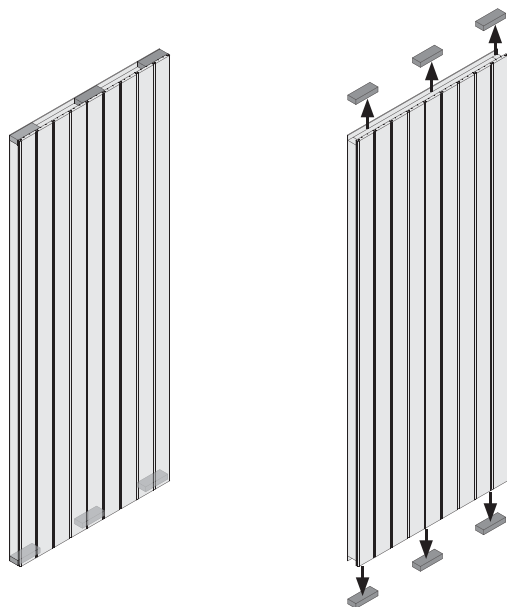

-  Vorsicht!
-  Attention!
-  Attention!
-  Voorzichtig!
-  Forsigtig!
-  Cuidado!
-  Occhio!
-  Pozor!

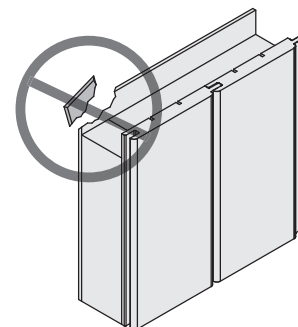

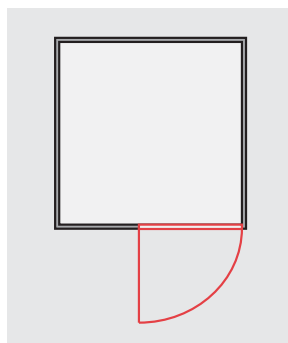
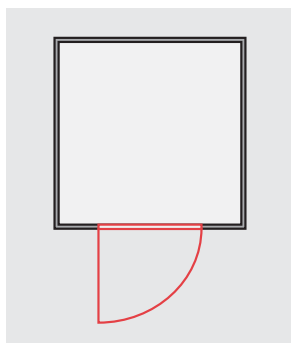
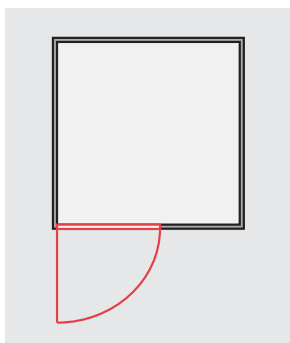
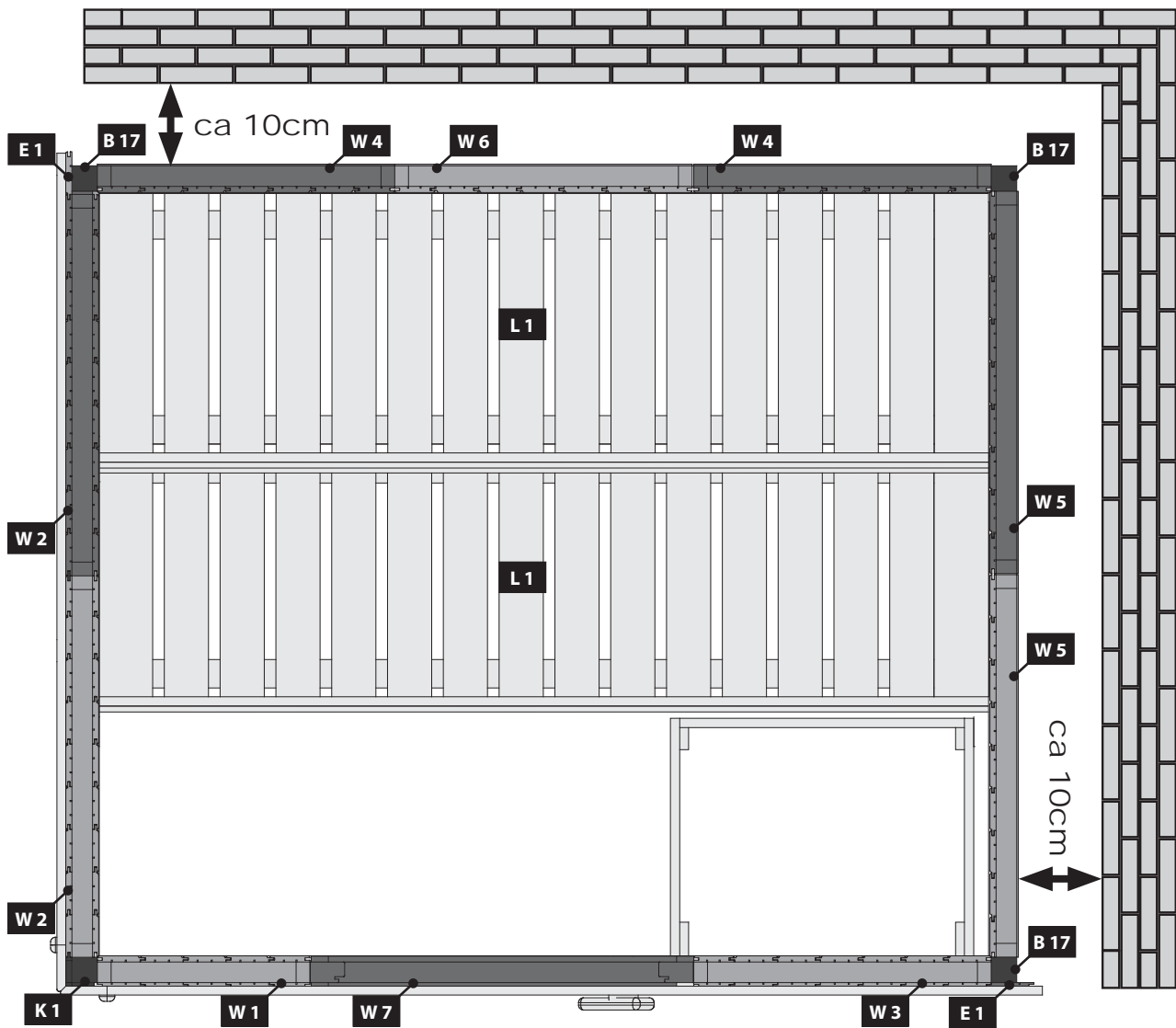

-  Einbau Tür
-  Installation door
-  Porte d'installation
-  Installatie deur
-  Installationsdør
-  Puerta de instalación
-  Porta di installazione
-  Montážní dveře

01 2x

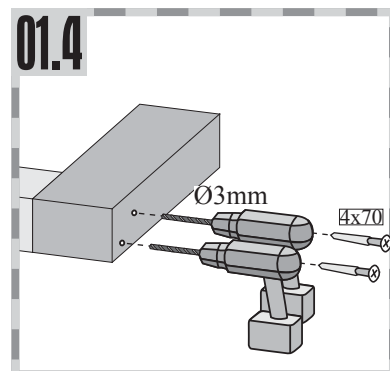
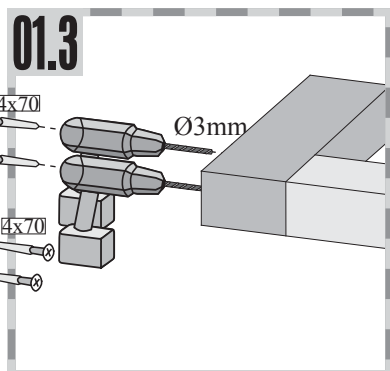
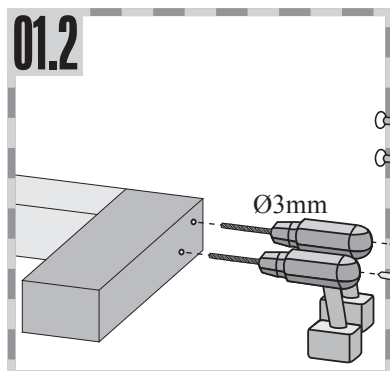
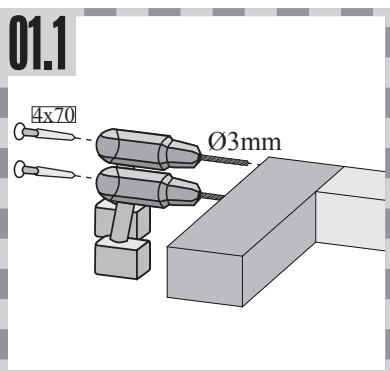
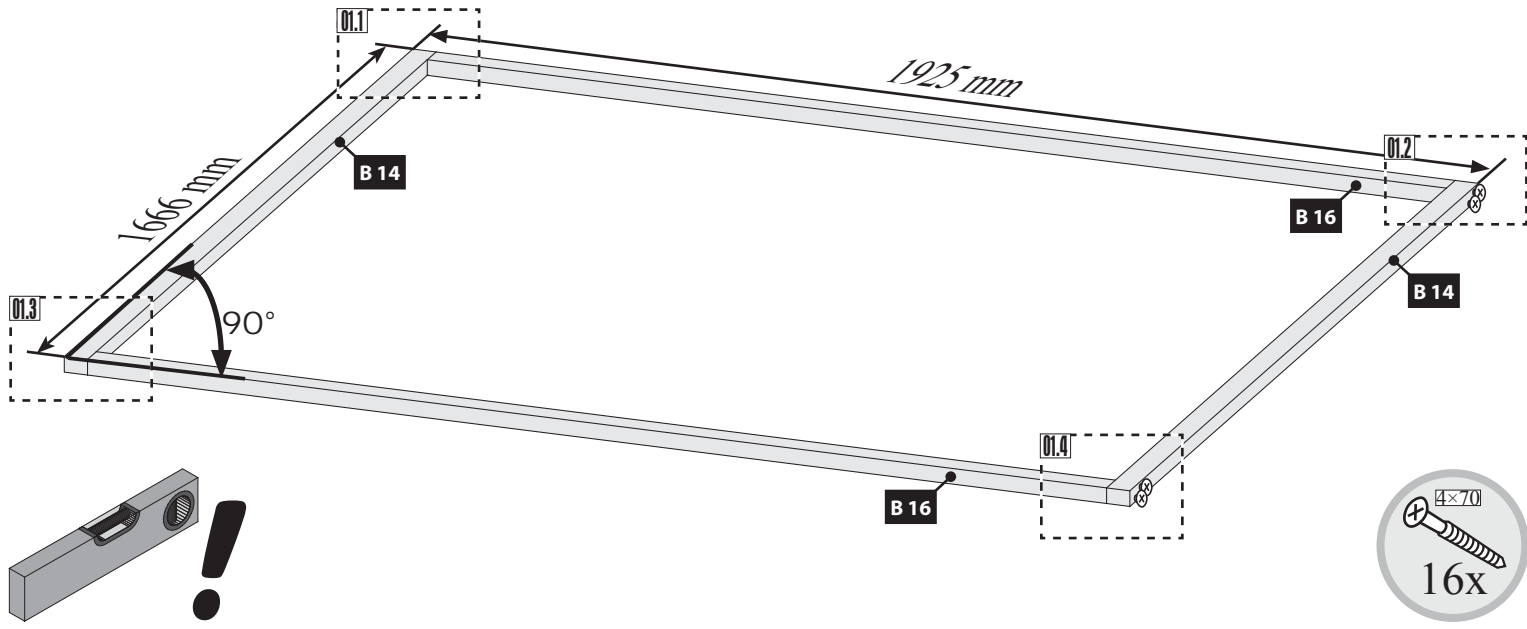

02

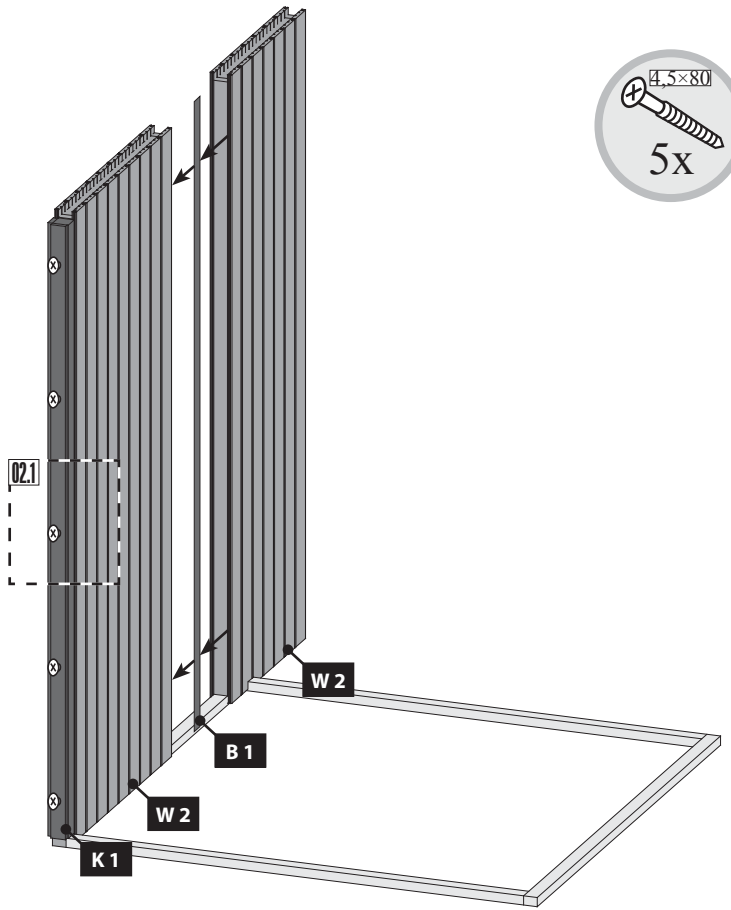

02.1

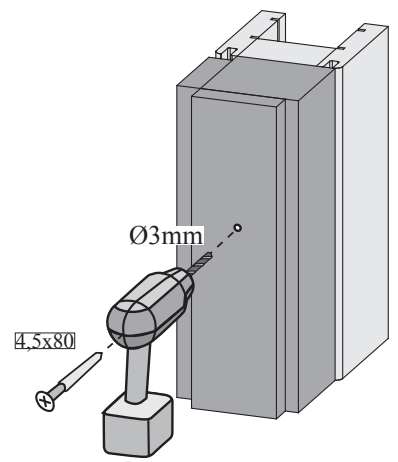

03

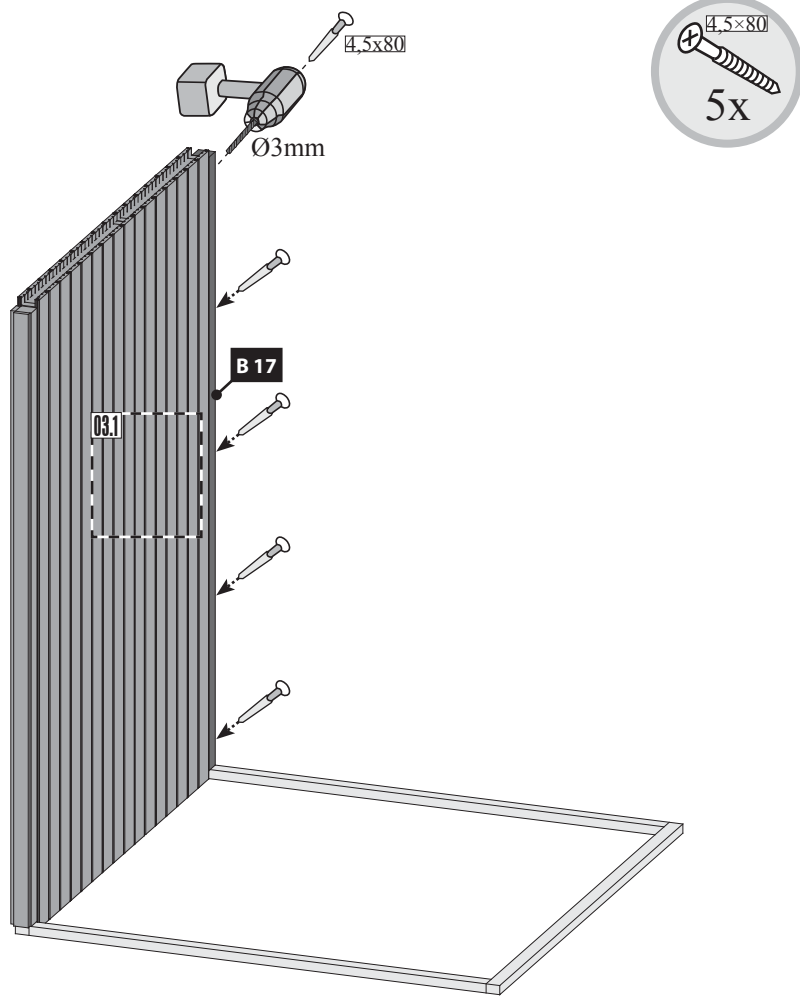

03.1

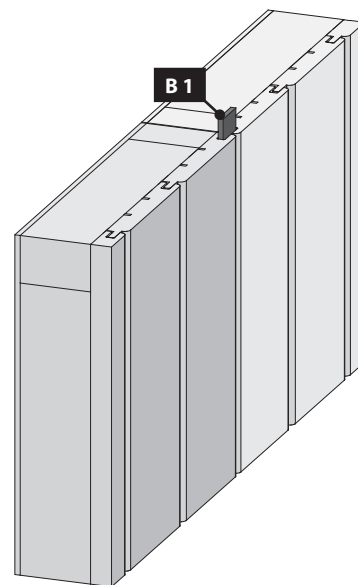

04

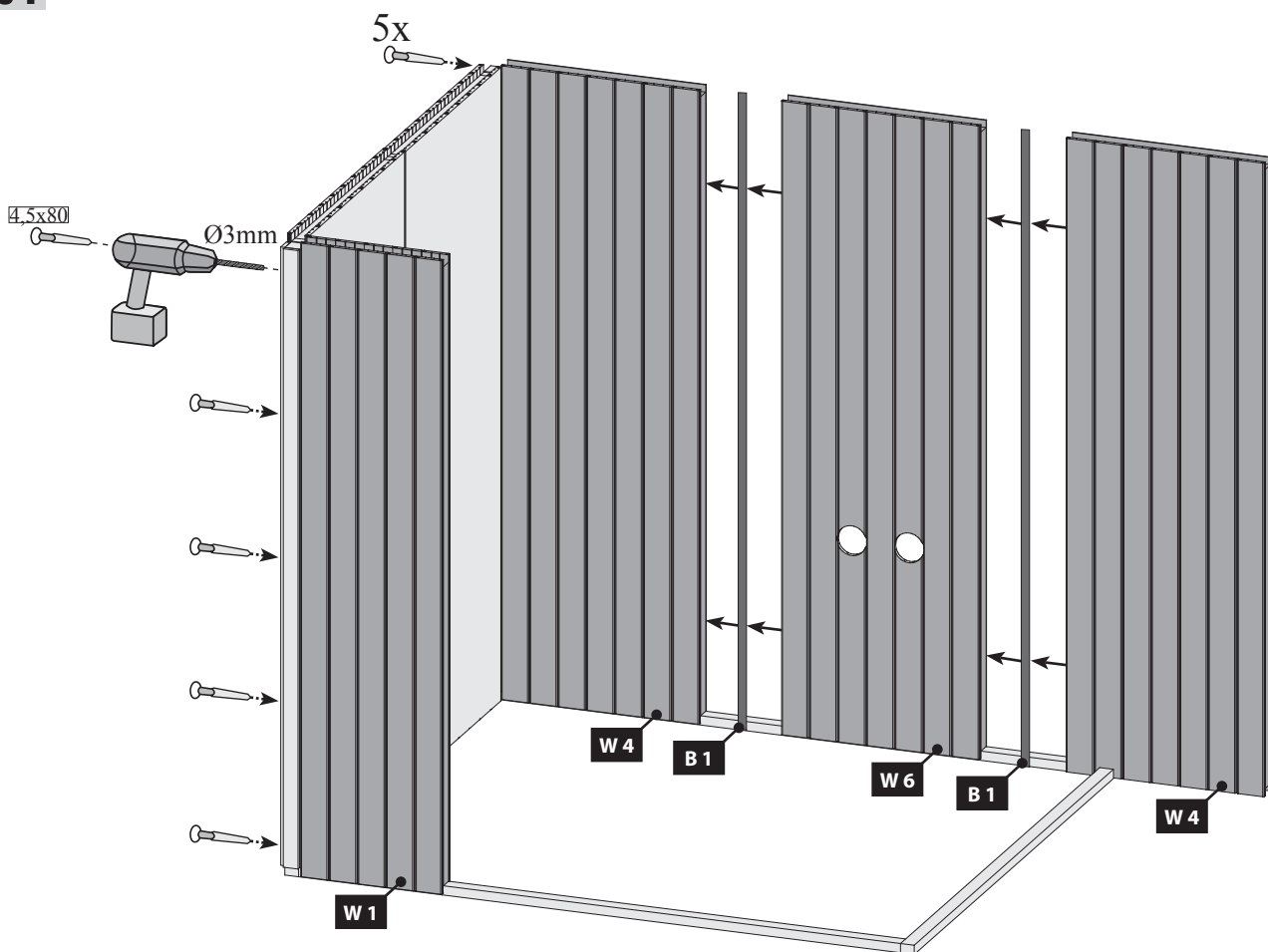

05

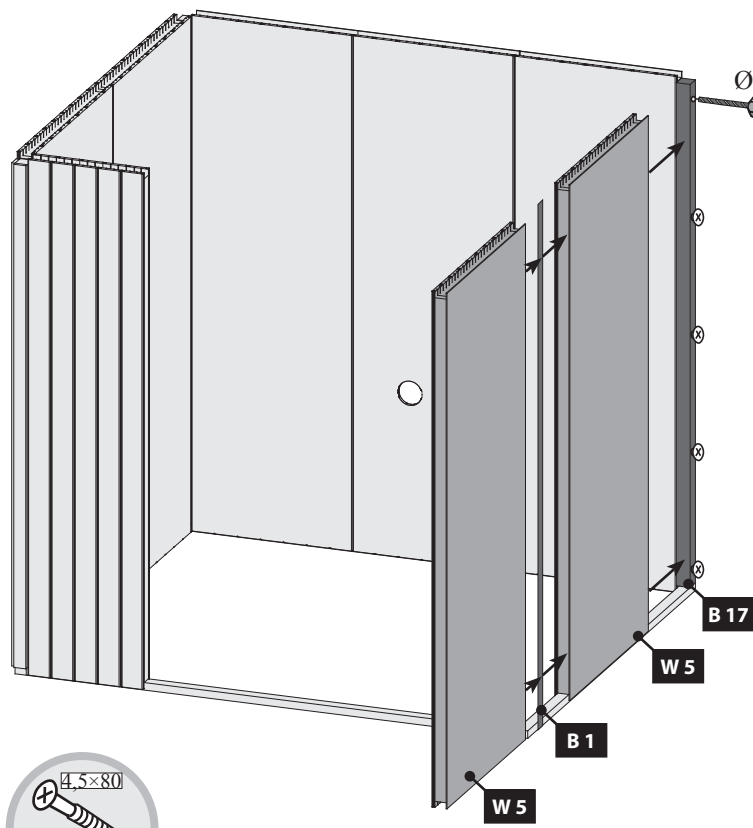

06

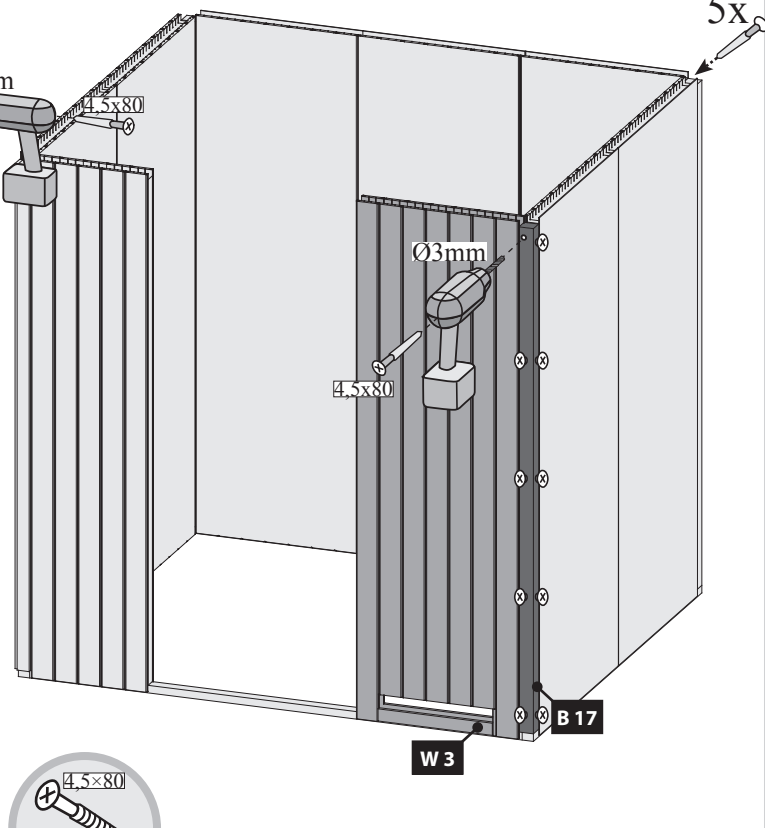

07

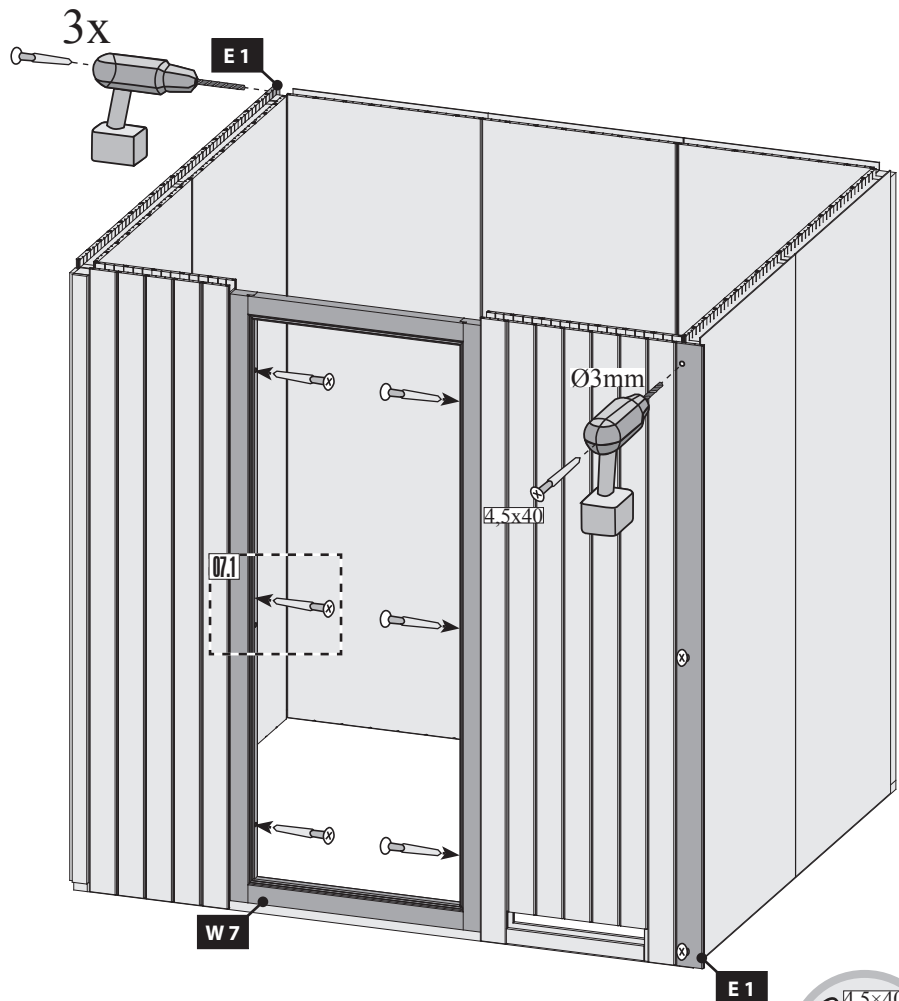

07.1-1

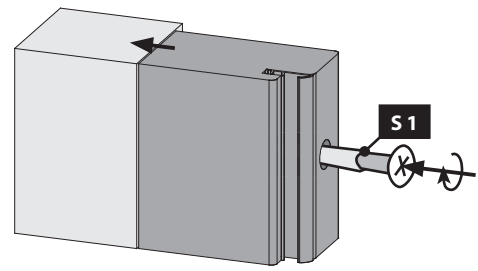

07.1-2

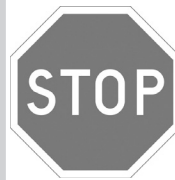
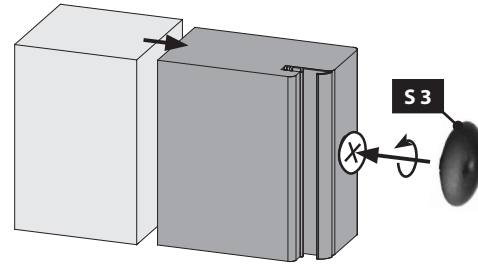

-  Einbau Saunatür
-  Installation de porte Sauna
-  Sauna door installation
-  Sauna deur installatie
-  Instalación de la puerta Sauna
-  Installazione porta Sauna
-  Sauna Instalace dveře

!!! 01 — 03 **!!!**

08

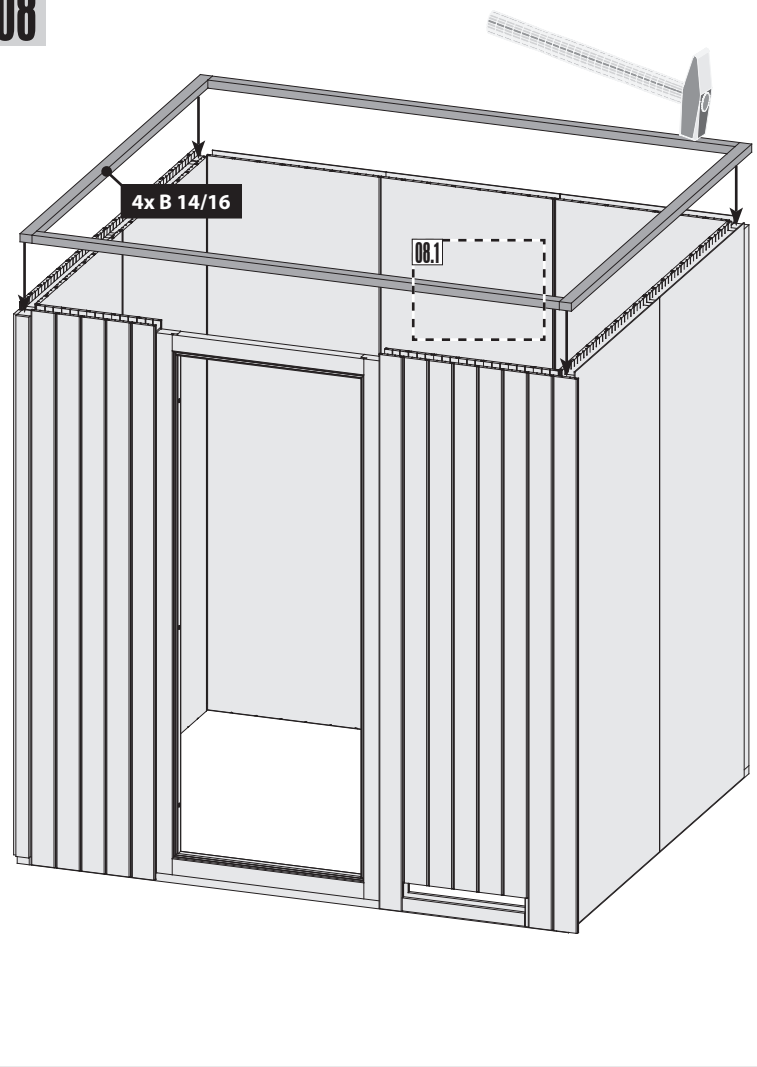

09

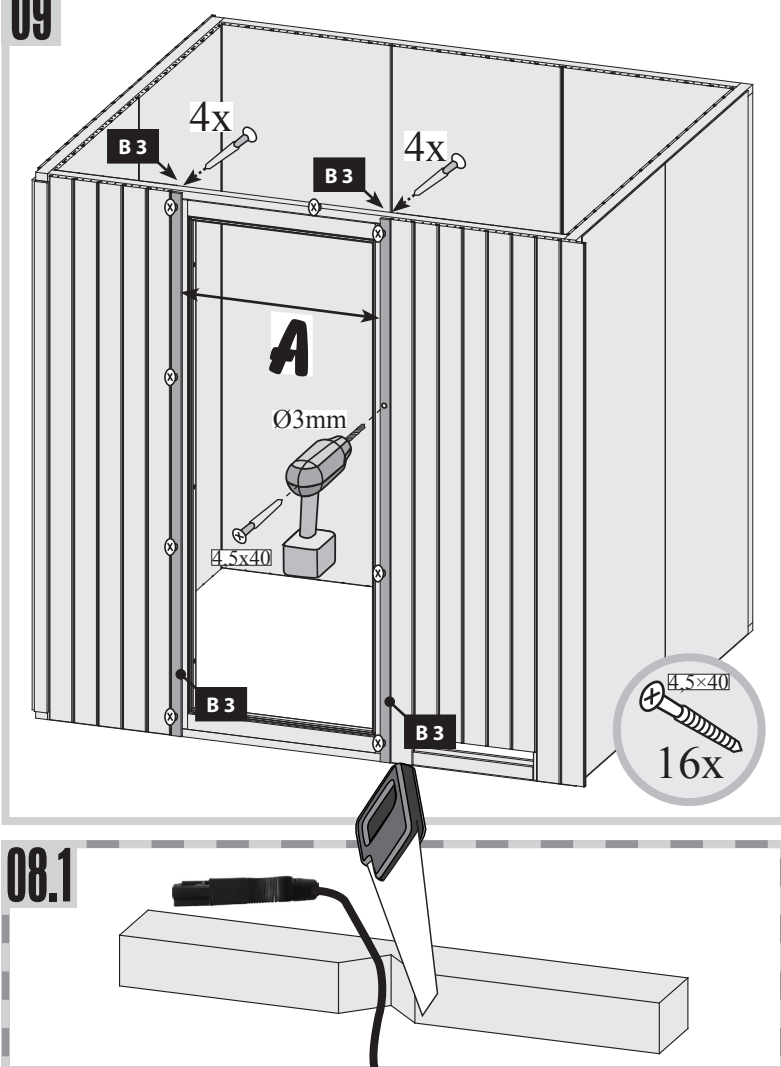

10

4x

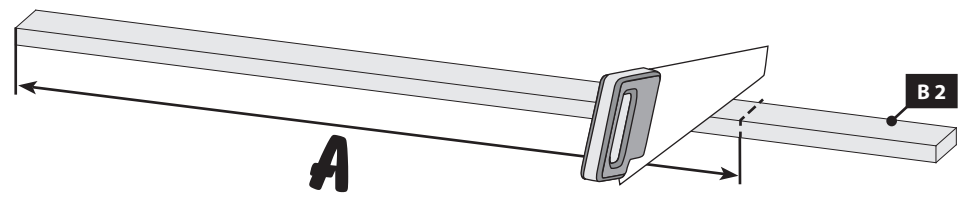

11

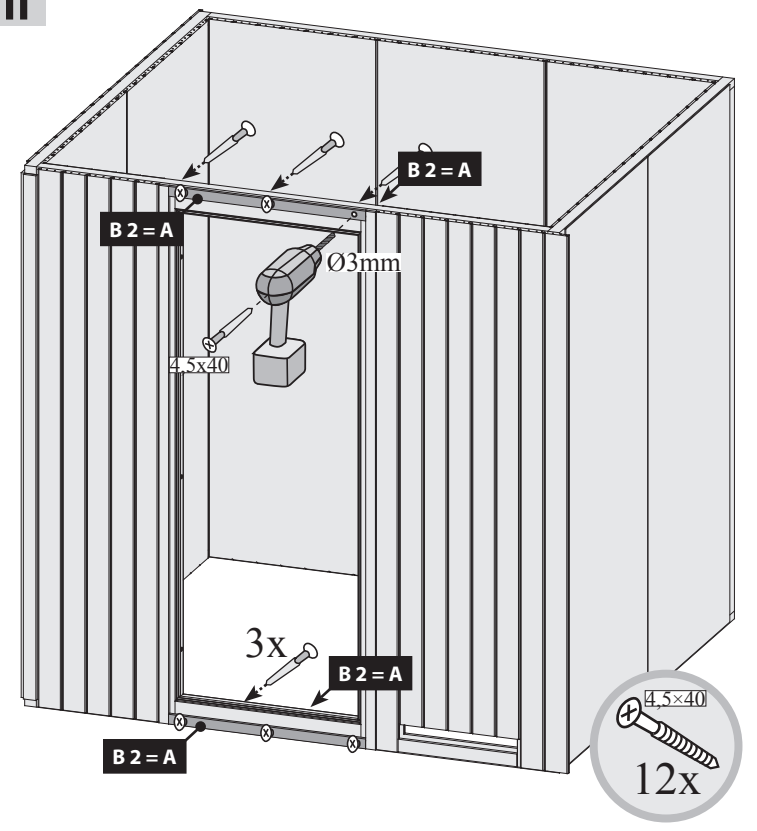

12

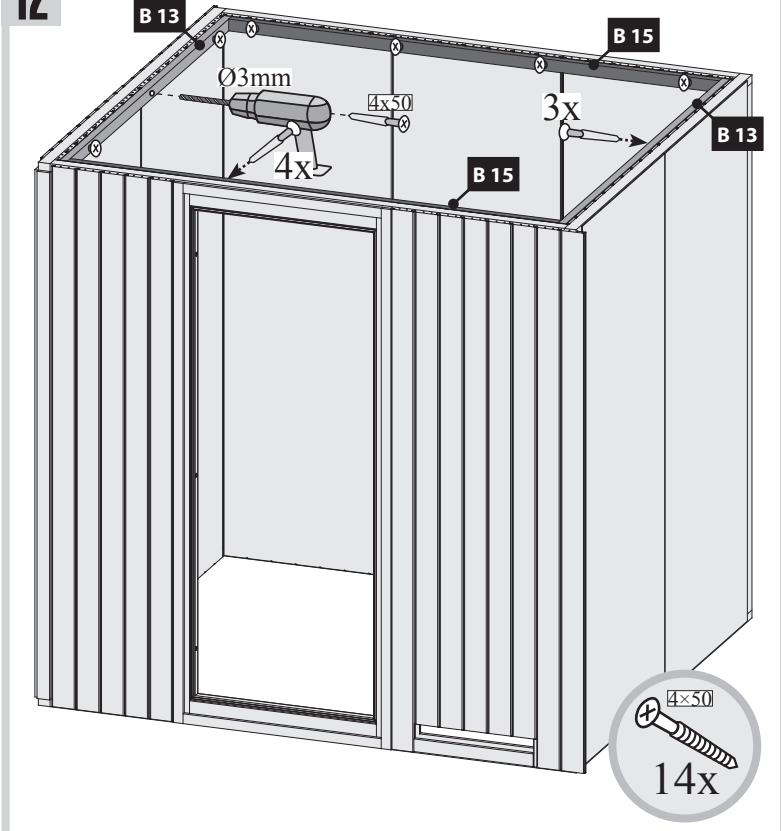

13

13.1

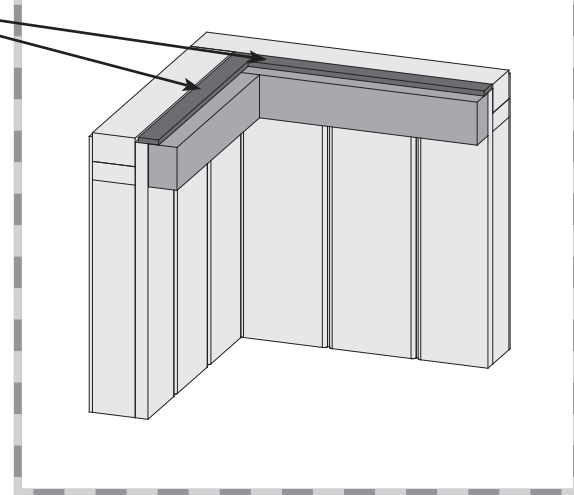
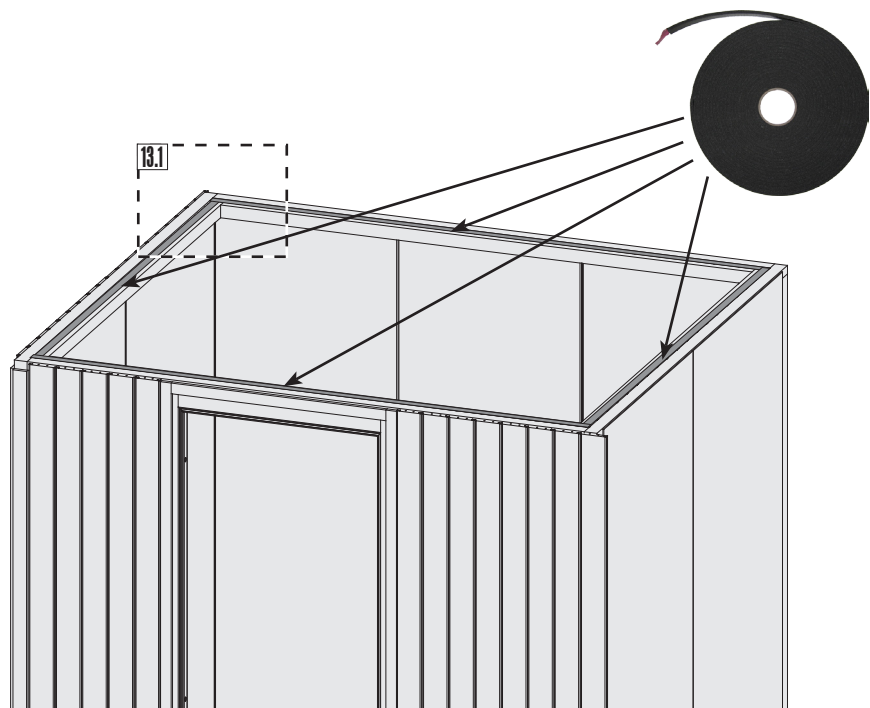

14

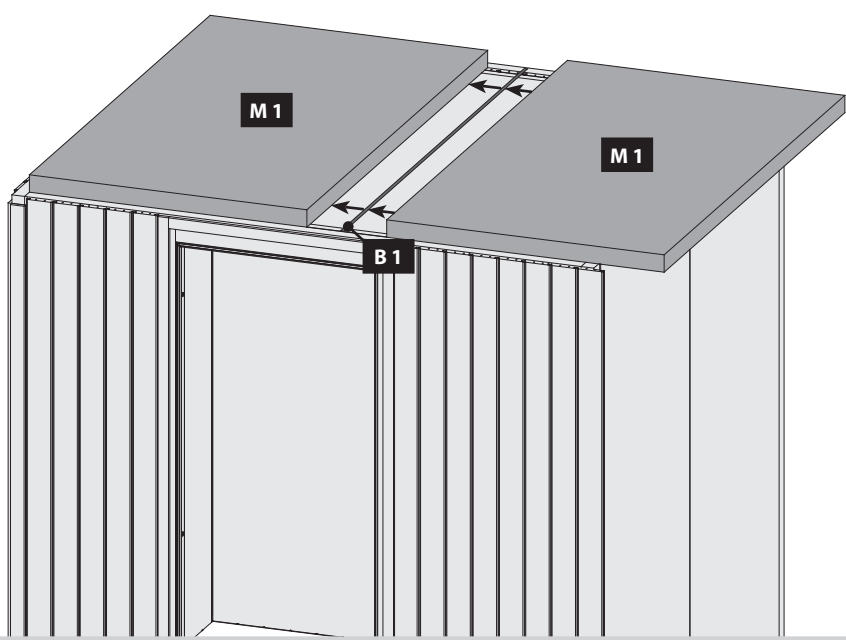

15

15.1

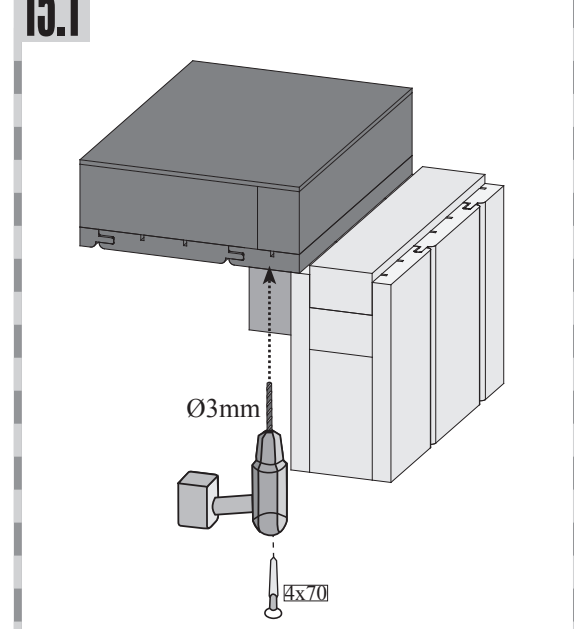
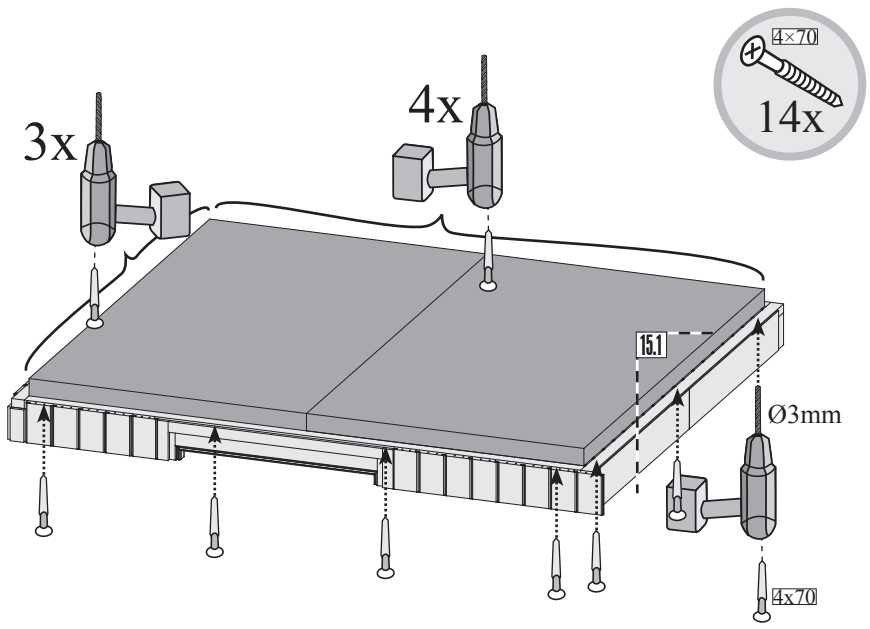

16

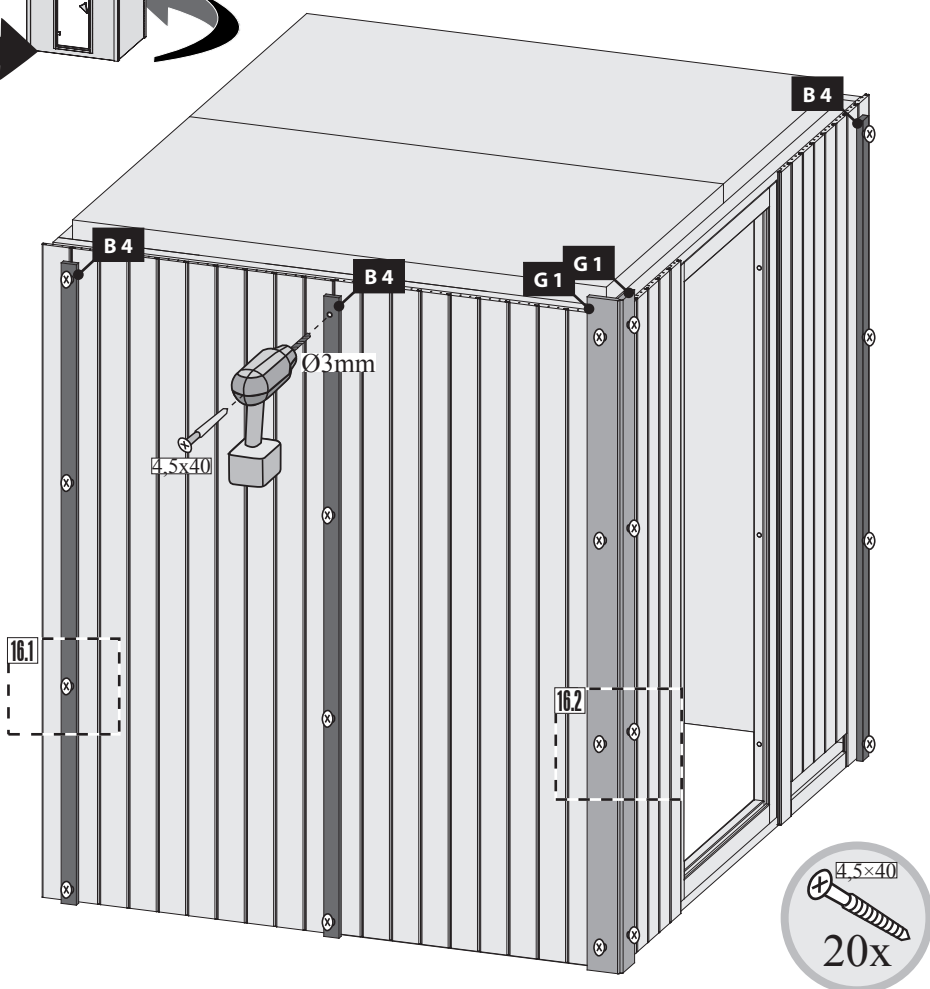
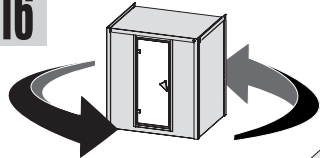

16.1

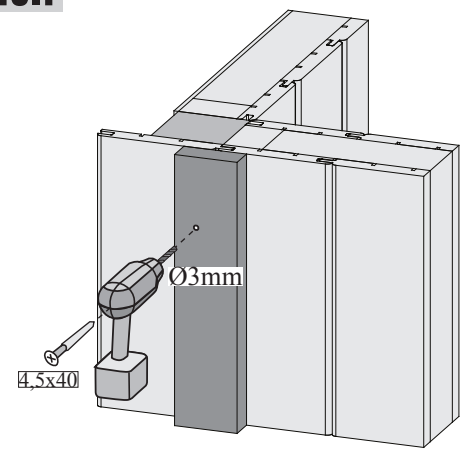

16.2

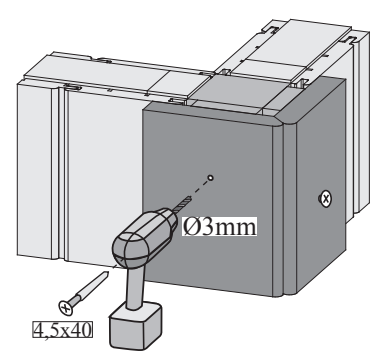

17

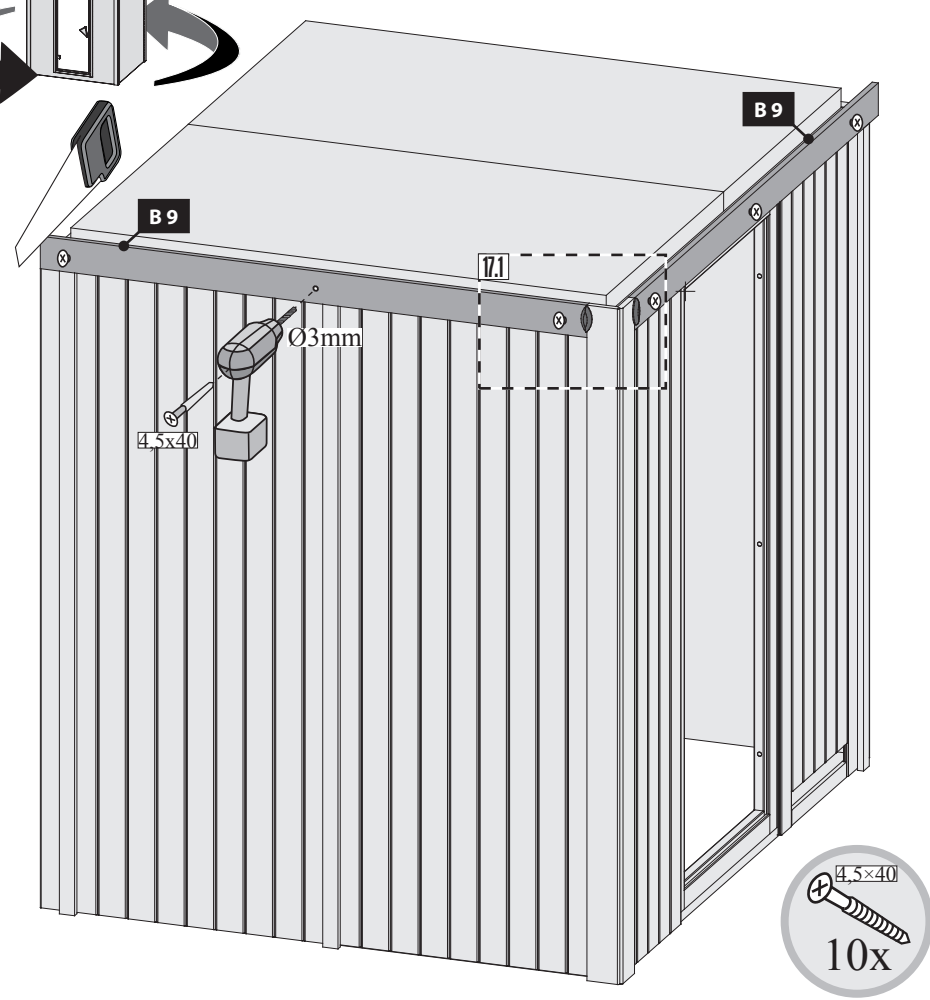
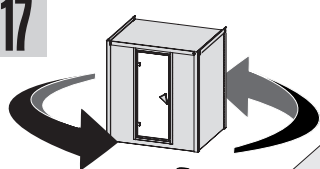

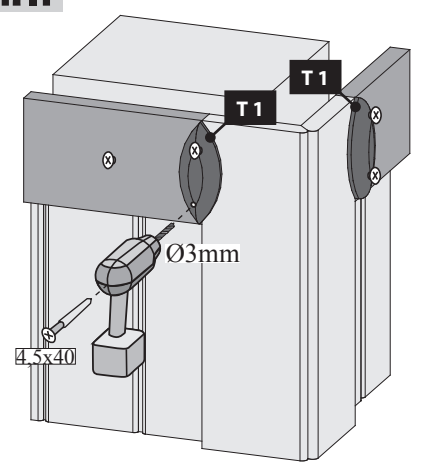

17.1



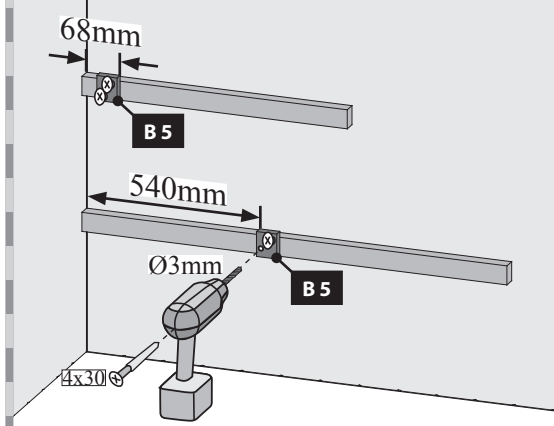
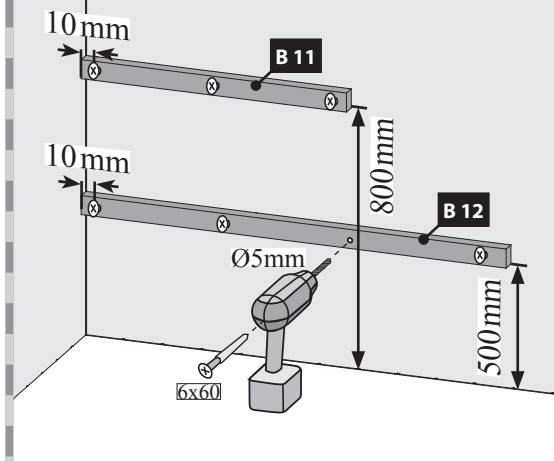
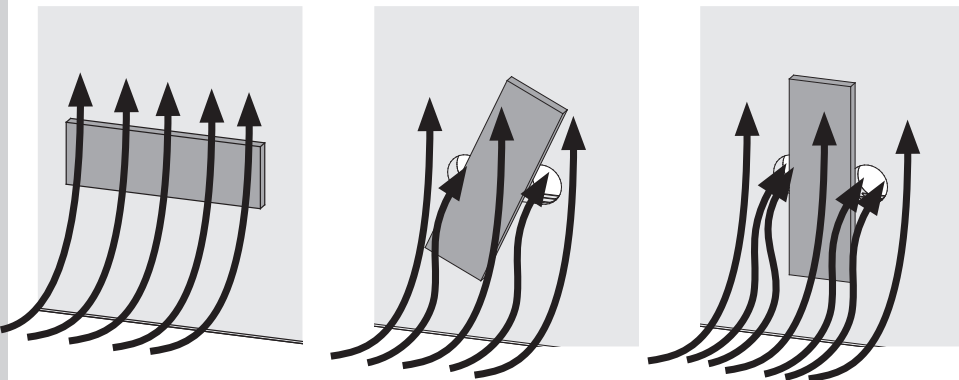
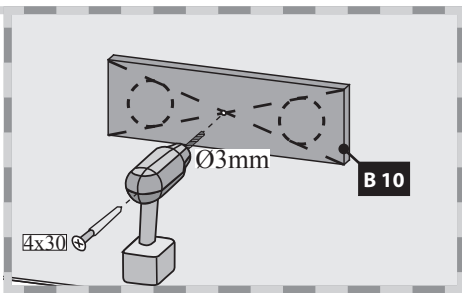
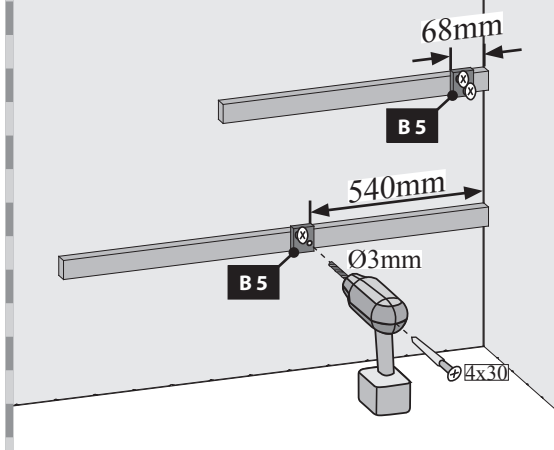
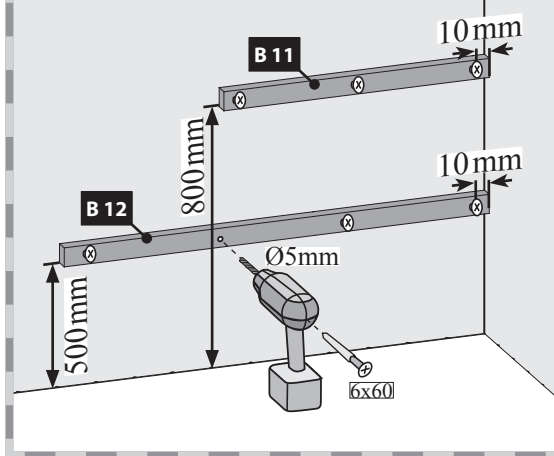
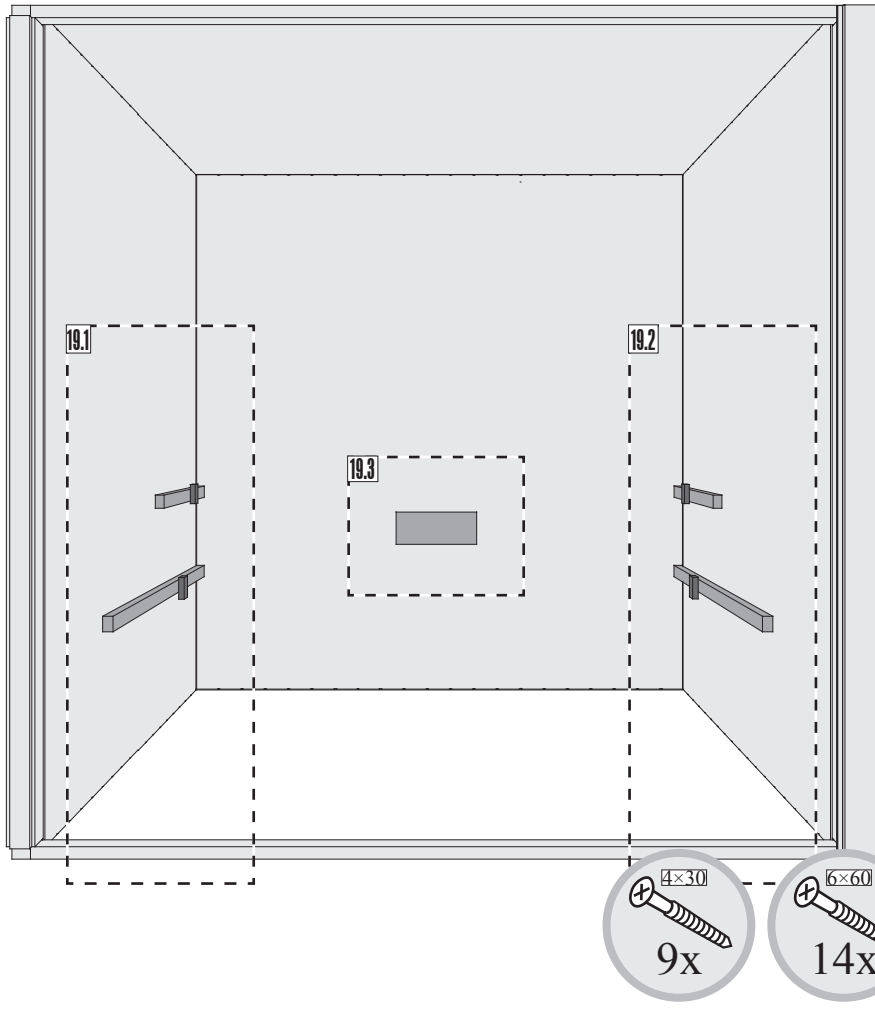

18







 Hier ist die Funktionsweise des Brettes abgebildet. Regeln Sie damit die Abluft nach Ihren eigenen Wünschen.

 Ceci représente le mode de fonctionnement de la planche. Avec elle, réglez l'écoulement de l'air selon vos désirs.

 This figure shows the functional principle of the board. Regulate the exhaust air according to your own wishes.

 Hier is de werking van het plankje afgebeeld. Regel daarmee de luchtafvoer naar eigen wens.

 Aquí está representada la forma de funcionamiento de la tabla. Regule con ello el aire de salida según sus propios deseos.

 Viene illustrato il principio di funzionamento della tavoletta di regolazione della ventilazione. Con essa si può regolare a piacere la ventilazione.

 Zde je zobrazená funkce desky. Regulujte s ní odsávací vzduch dle Vašeho přání.

20 2x

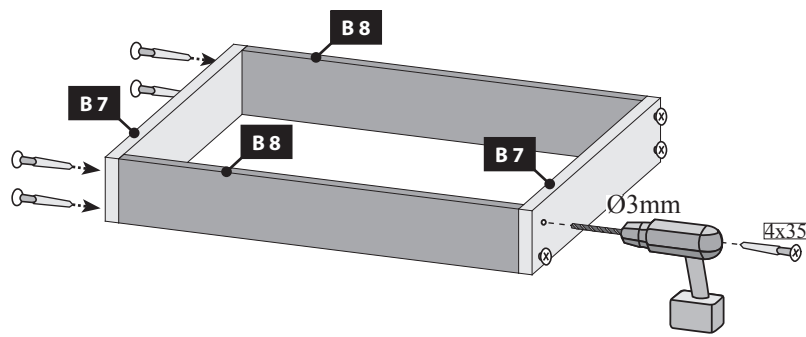

21 a

-  Nur bei 9 kW-Ofen
-  Seulement 9 kW chauffe
-  Only 9 kW heater
-  Slechts 9 kW heater
-  Sólo calentador de 9 kW
-  Solo riscaldamento 9 kW
-  Pouze topné těleso 9 kW

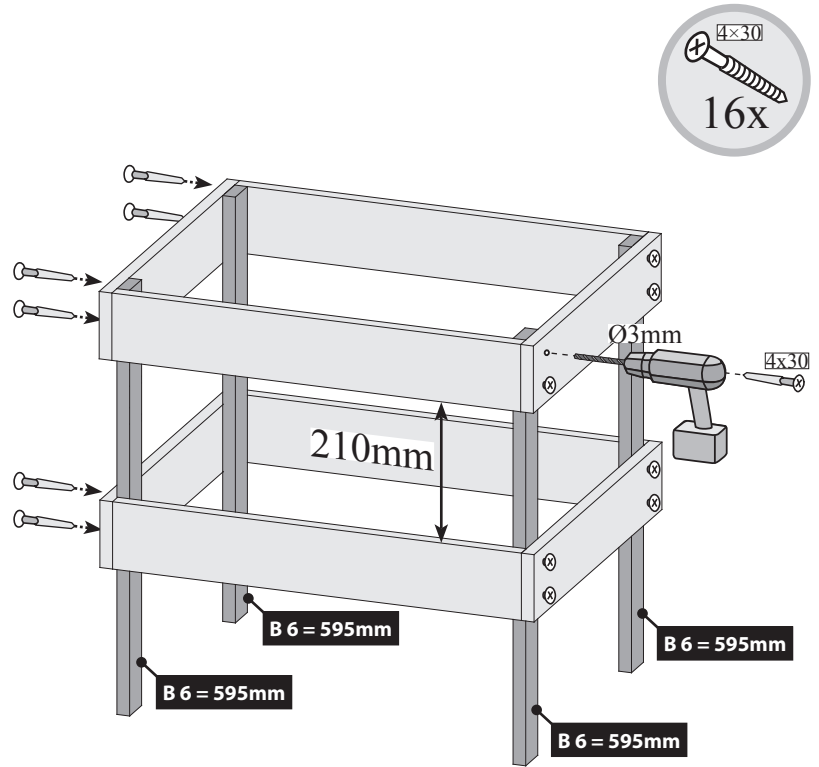
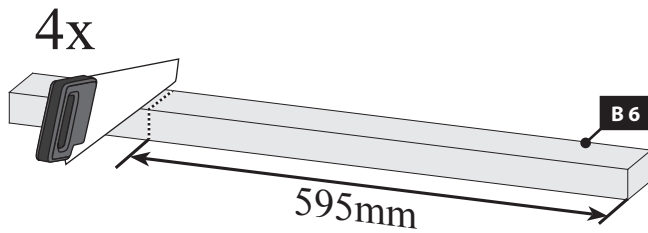

21 b

-  Bei allen anderen Öfen
-  Pour tous les autres fours
-  For all other furnaces
-  Voor alle andere ovens
-  Para todos los otros hornos
-  Per tutti gli altri tipi di forni
-  U všech ostatních pecích

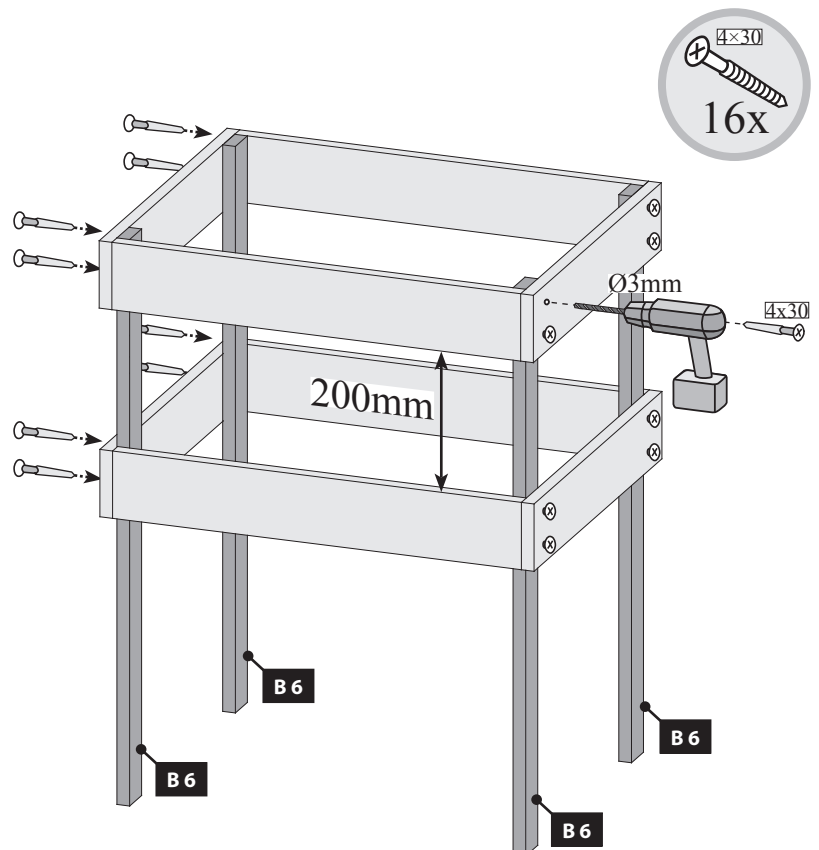

22 2x

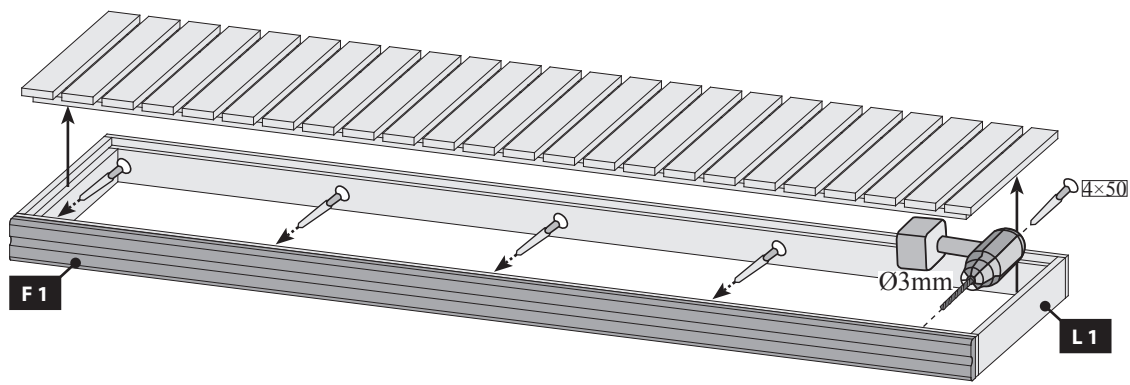

23

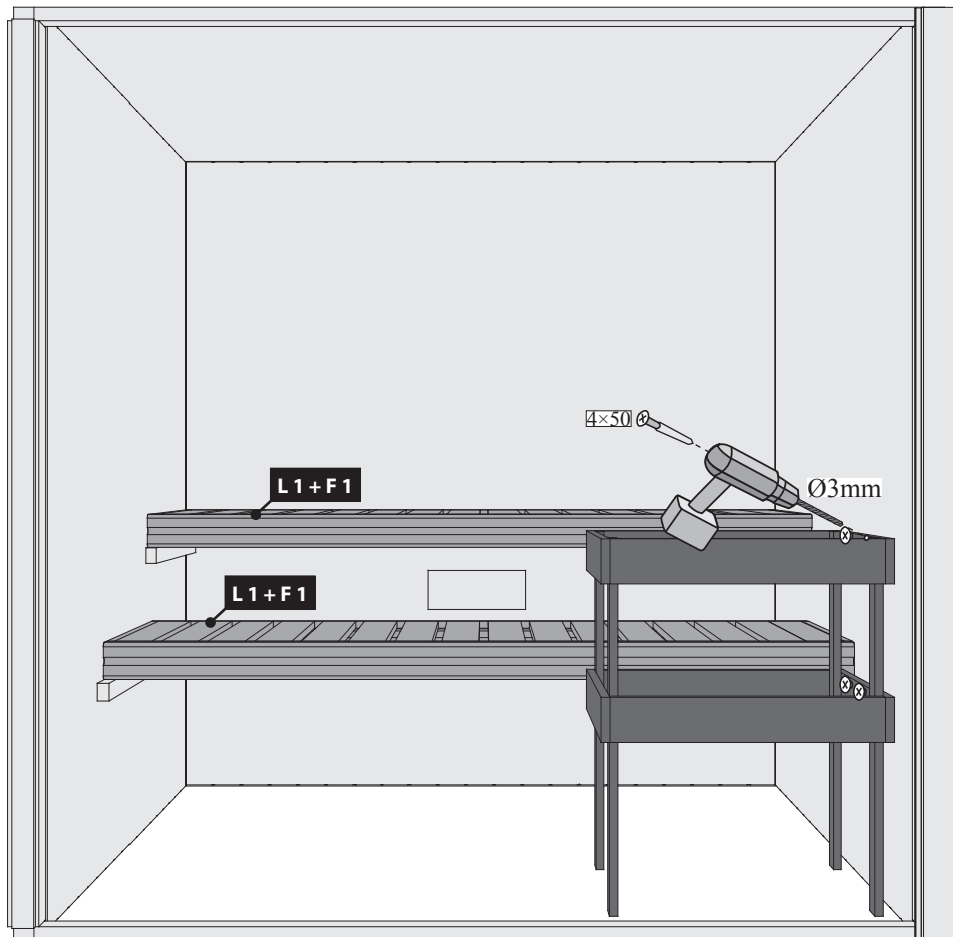

24

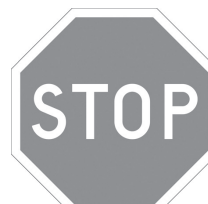
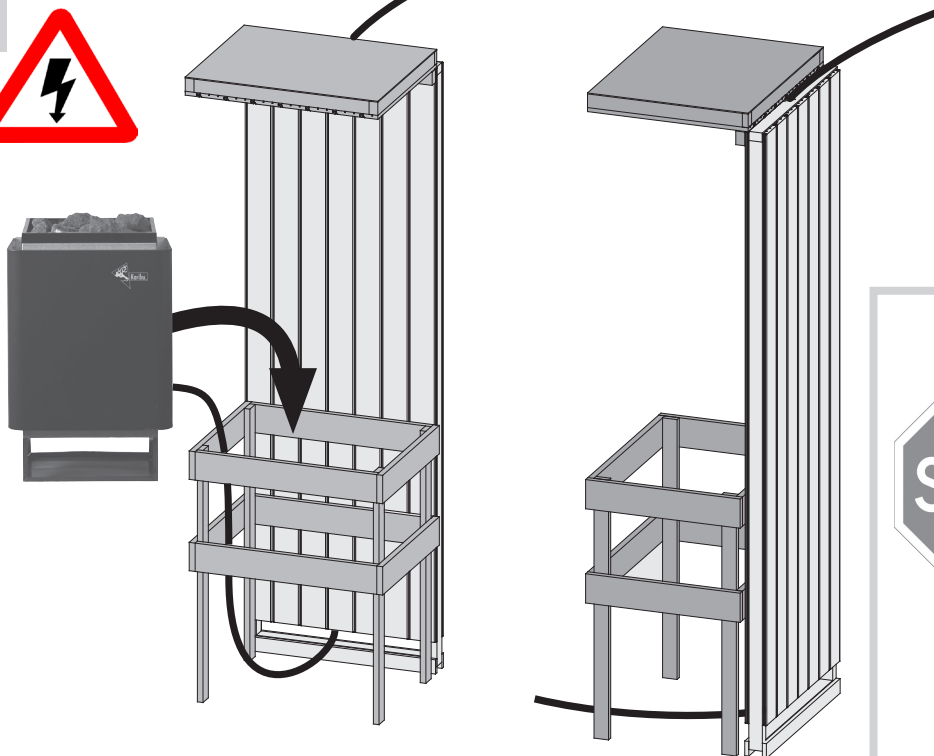

-  Einbau Saunatur
-  Installation de porte Sauna
-  Sauna door installation
-  Sauna deur installatie
-  Instalación de la puerta Sauna
-  Installazione porta Sauna
-  Sauna Instalace dveře

!!! 06 — **!!!**

70338

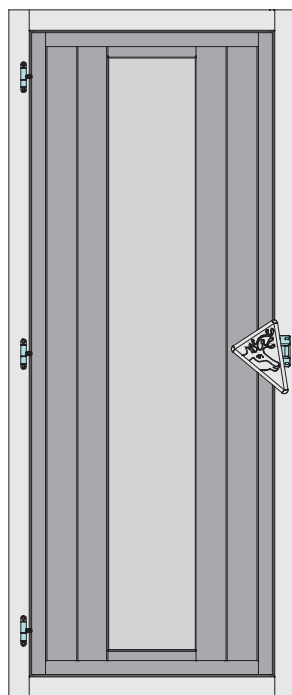

-  **Aufbauanleitung**
-  **Building Instructions**
-  **notice de montage**
-  **montagehandleiding**
-  **Montagevejledning**
-  **Instrucciones de construcción**
-  **Istruzioni per il montaggio**
-  **Montážní návod**

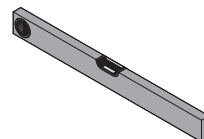
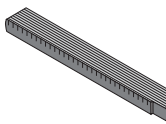
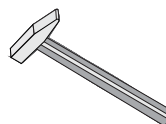
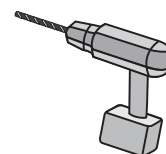
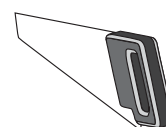



Vergleichen Sie zuerst die Material-liste mit Ihrem Paketinhalt! Bitte haben Sie Verständnis, dass Beanstandungen nur im nicht aufgebauten Zustand bearbeitet werden können!



Vergelijk eerst de lijst van materialen met de inhoud van uw pakket! Reclamaties kunnen alleen in behandeling worden genomen zolang de onderdelen nog niet zijn gemonteerd!



Confrontate questa distinta materiali prima con il contenuto del pacchetto! Vi preghiamo di comprendere che eventuali reclami possono essere accolti solo prima del montaggio!



First compare the list of materials with your package contents! Please understand that complaints can be processed in the non-built status only!



Start med at kontrollere materialelisten med indholdet af den leverede pakke! Vi gør venligst opmærksom på at reklamationer kun kan behandles for materialer som ikke er blevet bearbejdet!



Nejprve přezkontrolujte obsah balení podle materiálového listu! Mějte pochopení pro to, že případnou reklamaci se můžeme zabývat pouze tehdy, když díly nebudou smontované! Za pomoci tohoto seznamu můžete jednotlivé díly přiřadit k montážnímu návodu.



Commencez par comparer la liste du matériel avec le contenu de votre paquet! Sachez que nous traitons uniquement les réclamations concernant le matériel à l'état non monté!



En primer lugar, compare la lista de material con el contenido del paquete. Rogamos entienda que las reclamaciones sólo pueden ser tramitadas antes de montar el objeto!

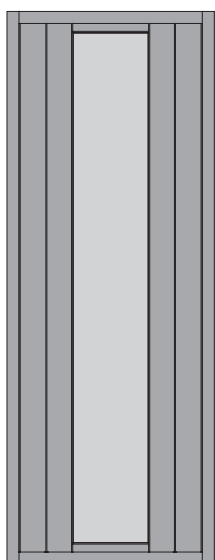
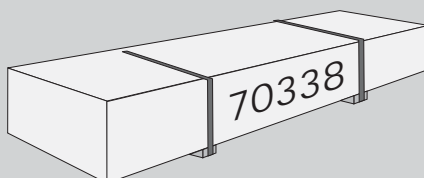

1 x

ID 26494

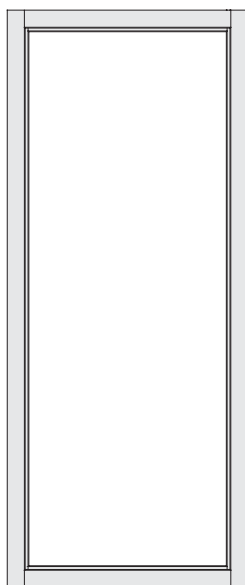

1 x

ID 26499

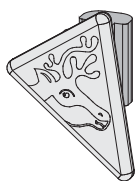

1 x

ID 26114

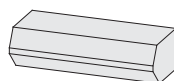

1 x

ID 64800

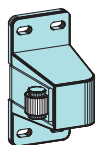

1 x

ID 64245

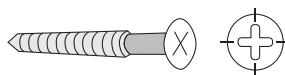

13 x

4 x 30 mm

ID 3686

2 x

4 x 50 mm

ID 3688

2 x

6 x 60 mm

ID 14014

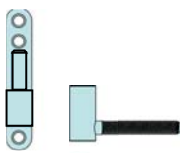

3 x

ID 3717

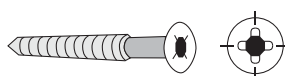

2 x

4,5 x 70 mm

ID 27178







2 x





ID 26116



Bitte beachten Sie, dass es sich bei einem Spontanbruch infolge von Nickelsulfideinschlüssen um Glasbrüche handelt, die nicht auf Verarbeitungsfehler basieren und somit nicht durch den Hersteller und dem Verarbeiter zu vertreten sind. Der Spontanbruch ist als hinzunehmendes Allgemeinrisiko anzusehen.

Bitte haben Sie Verständnis, dass wir eine Nachlieferung nur gegen Berechnung ausführen können.

-  Einbau Glastür
-  Installation of glass door
-  Montage porte en verre
-  Montage van de glazen deur

-  Installationsglasdør
-  Montaje de la puerta de cristal
-  Installazione portello di vetro
-  Sauna Instalace dveře

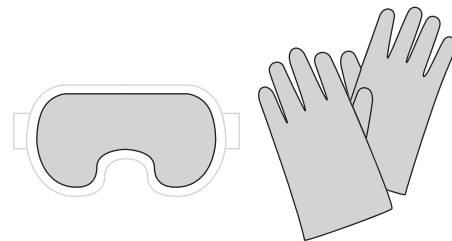

01



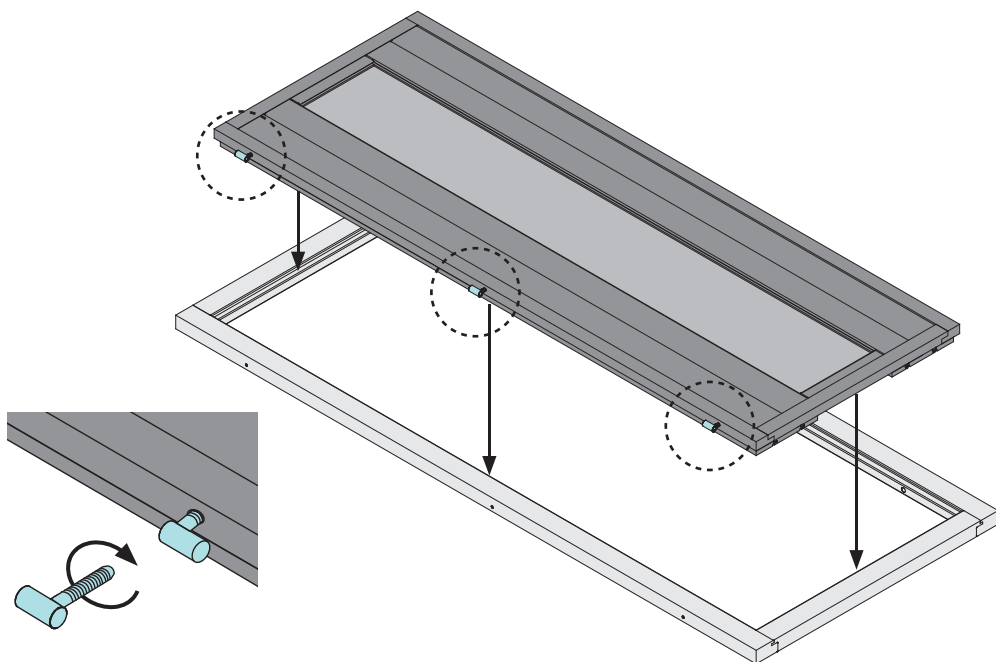

-  Tür in den Rahmen legen
-  Put the door in the frame
-  Mettez la porte dans le cadre
-  Plaats de deur in het frame
-  Sæt døren i rammen
-  Pon la puerta en el marco
-  Metti la porta nel telaio
-  Vložte dveře do rámu



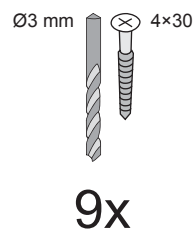
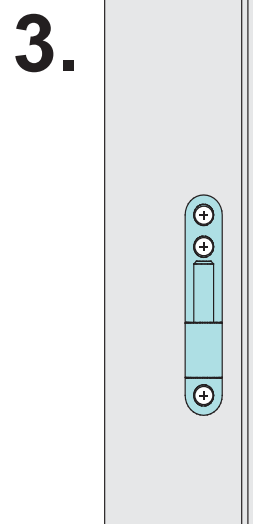
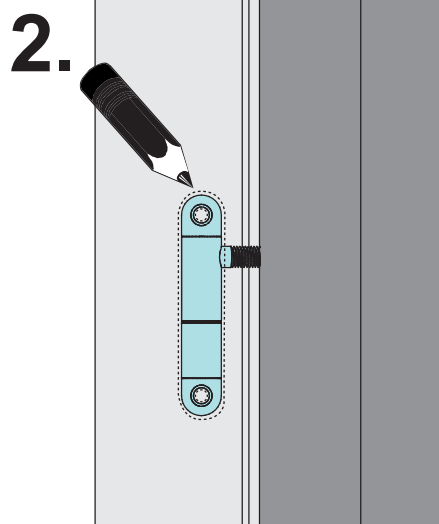
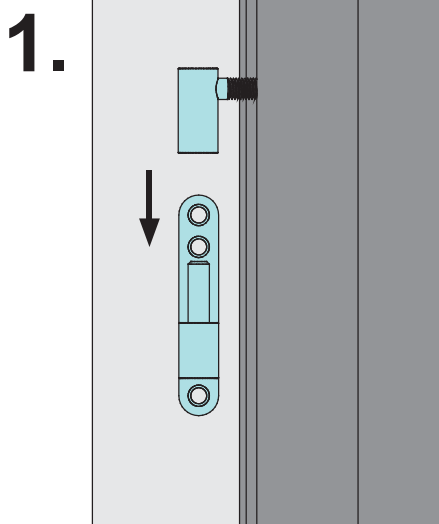
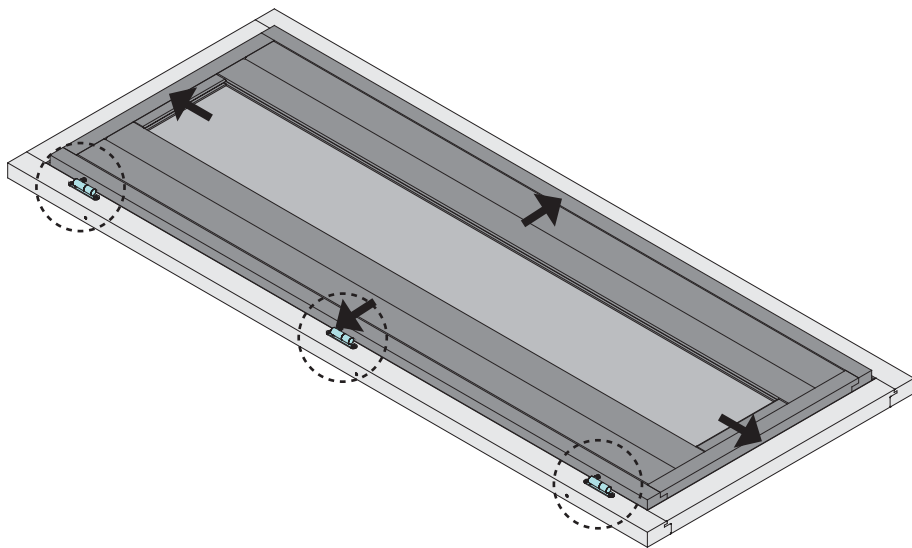



02

-  Tür im Rahmen ausrichten
-  Center the door in the frame
-  Aligner la porte dans le cadre
-  Lijn de deur in het frame uit
-  Juster døren i rammen
-  Alinea la puerta en el marco
-  Allinea la porta nella cornice
-  Zarovnejte dveře do rámu



 Einbau Glastür
 Installation of glass door
 Montage porte en verre
 Montage van de glazen deur

 Installationsglasdør
 Montaje de la puerta de cristal
 Installazione portello di vetro
 Sauna Instalace dveře

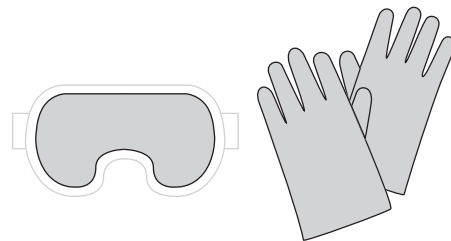

03

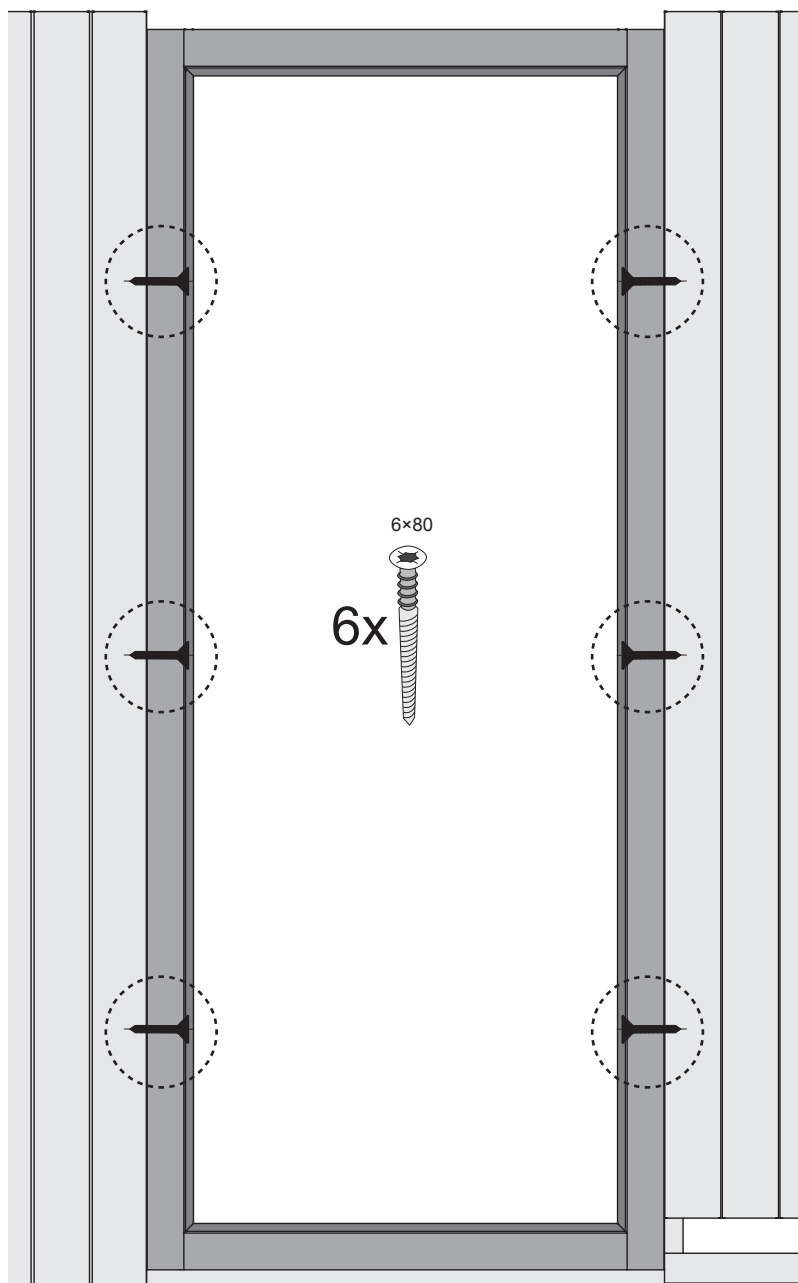
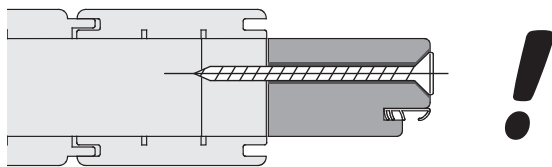

1.

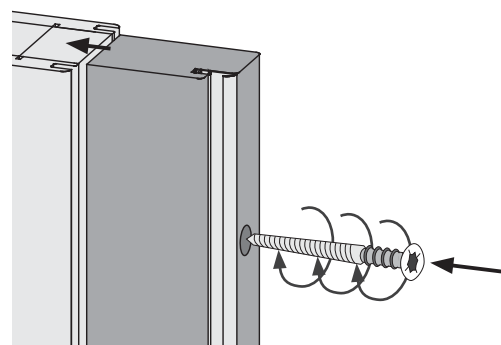

2.

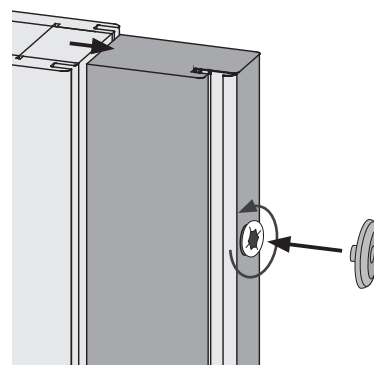

1.

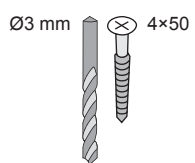
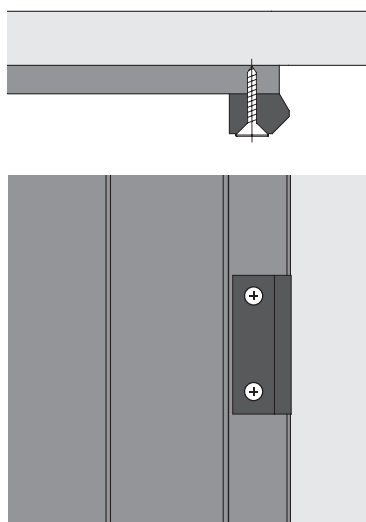

2x

2.

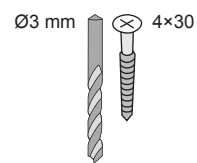
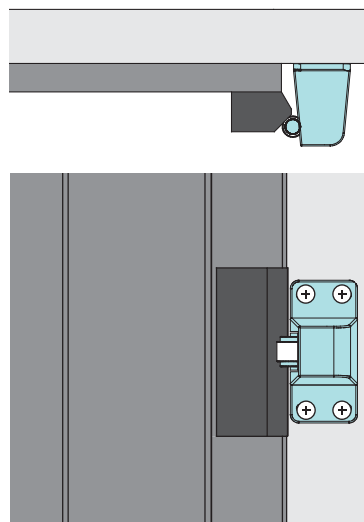

4x

3.

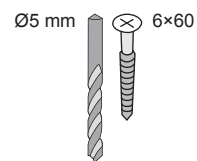
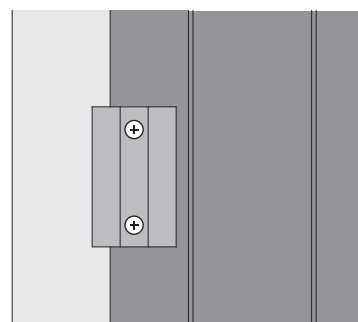
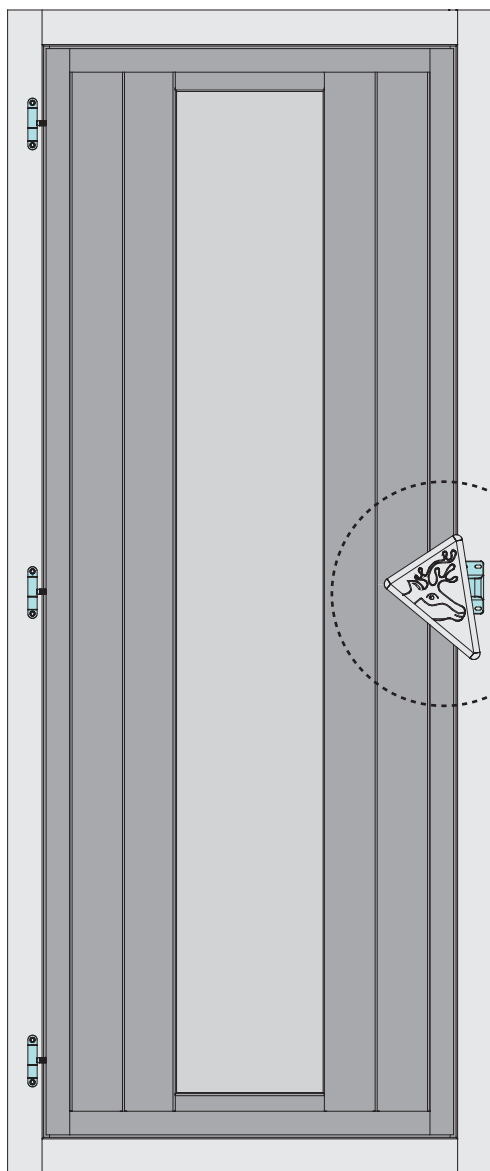

2x

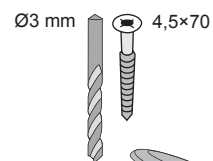
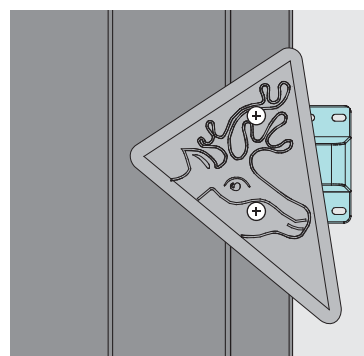
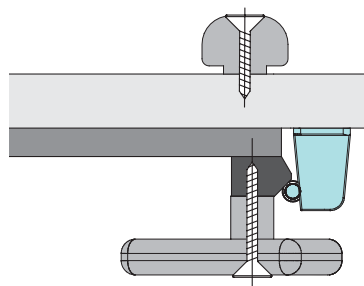

2x