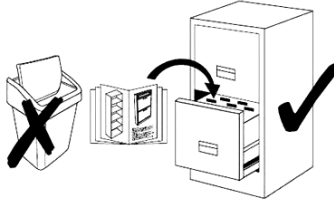
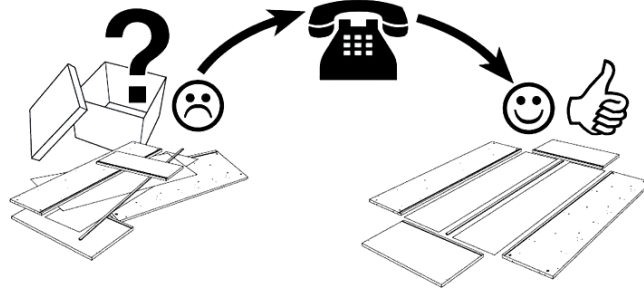

- (D) Montageanleitung
- (NL) Handleiding voor de montage
- (HU) Szerelési útmutató
- (GB) Assembly instructions

- (PL) Instrukcja montażu
- (RO) Instrucțiuni de montaj
- (FR) Notice de montage
- (CZ) Montážní návod
- (TR) Montaj talimatı
- (IT) Istruzioni di montaggio
- (SK) Návod na montáž
- (RU) Инструкция по монтажу

**Service • Assistenza • Dienstverlening • Serwis  
Servis • Szerviz • Сервисная служба**

Name • Nom • Nome • Naam • Nazwa • Jméno • Názov • Név • Denumire • Ísim • Название	
Nr. • No. • N° • Номер • Č • Sz	
Typ • Type • Тип • Típus • Tipo • Тип	

<b>1</b>	1x	ca. 2002 x 330 mm
<b>2a</b>	1x	ca. 1981 x 330 mm
<b>3b</b>	1x	ca. 2002 x 330 mm
<b>4b</b>	1x	ca. 318 x 330 mm

<b>50b</b>	2x	ca. 318 x 315 mm
<b>51b</b>	1x	ca. 318 x 315 mm
<b>6</b>	4x	ca. 352 x 497 mm
<b>7b</b>	1x	ca. 318 x 330 mm

**1** ≠ **3b**



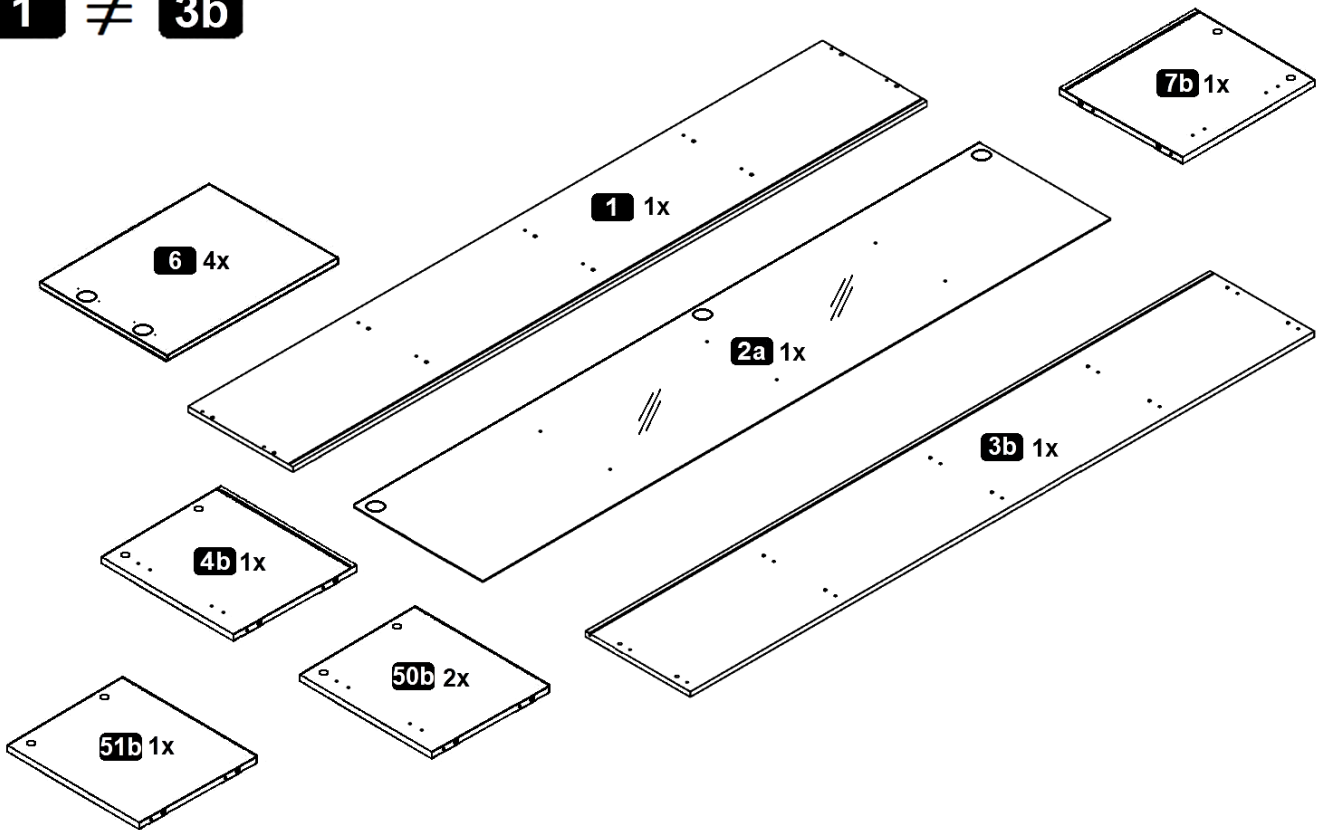

<b>A</b> 8,0 x 30 mm  <b>20x</b>	<b>B</b>  <b>10x</b>	<b>C</b>  <b>10x</b>
<b>H</b> Ø35 Kr.0 3,5x13 mm  <b>4x</b>	<b>I</b> h=2  <b>8x</b>	<b>J</b>  <b>4x</b>
<b>O</b> 5,0 x 50 mm  <b>10x</b>	<b>X</b> 2,7 x 20 mm  <b>6x</b>	<b>L</b> Ø35 Kr.8 3,5x13 mm  <b>4x</b>
<b>Y</b> M4x16 mm  <b>12x</b>	<b>V</b> 4,0x17 mm  <b>18x</b>	<b>Z</b>  <b>6x</b>

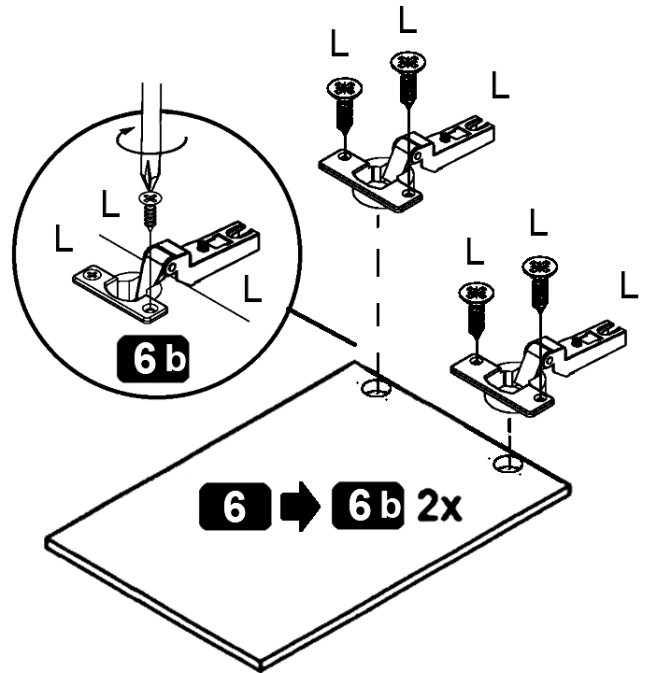
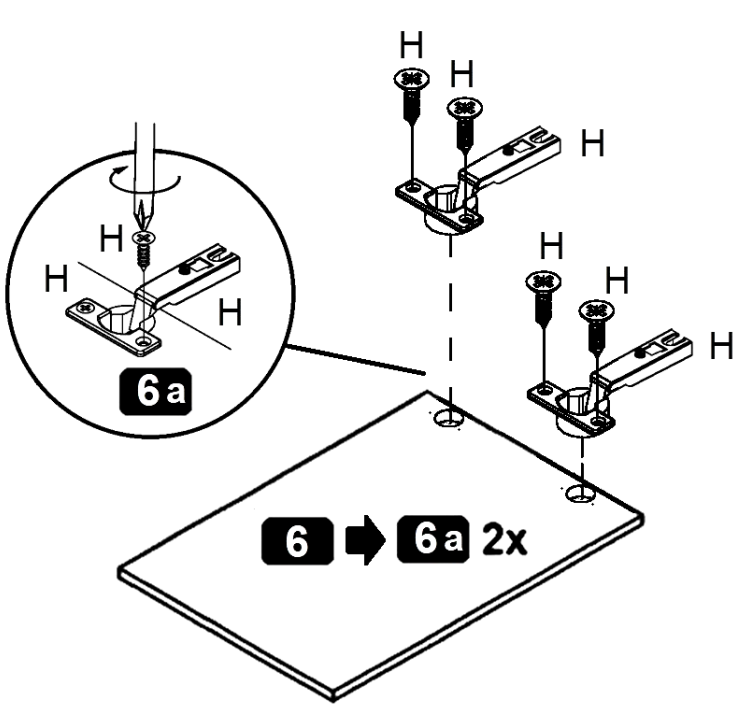
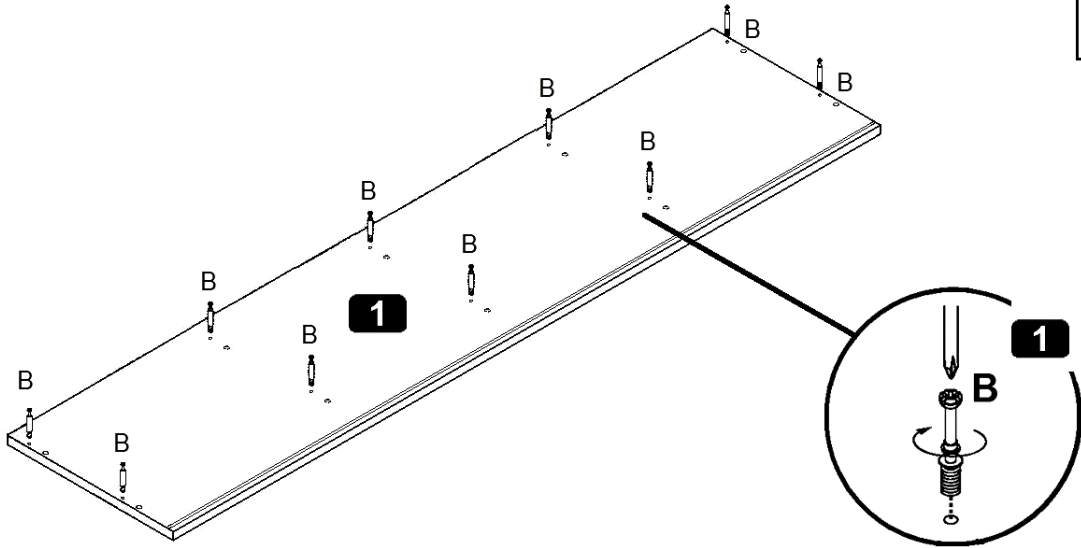
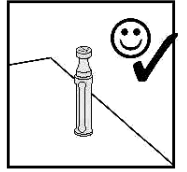
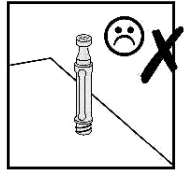
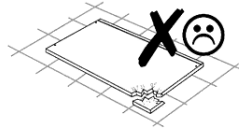
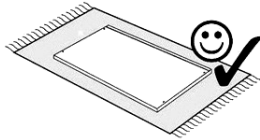
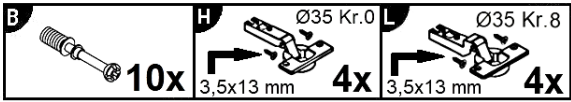
**1**



# 2

<b>A</b> 8,0 x 30 mm	<b>C</b>	<b>I</b> h=2
 <b>20x</b>	 <b>10x</b>	 <b>8x</b>

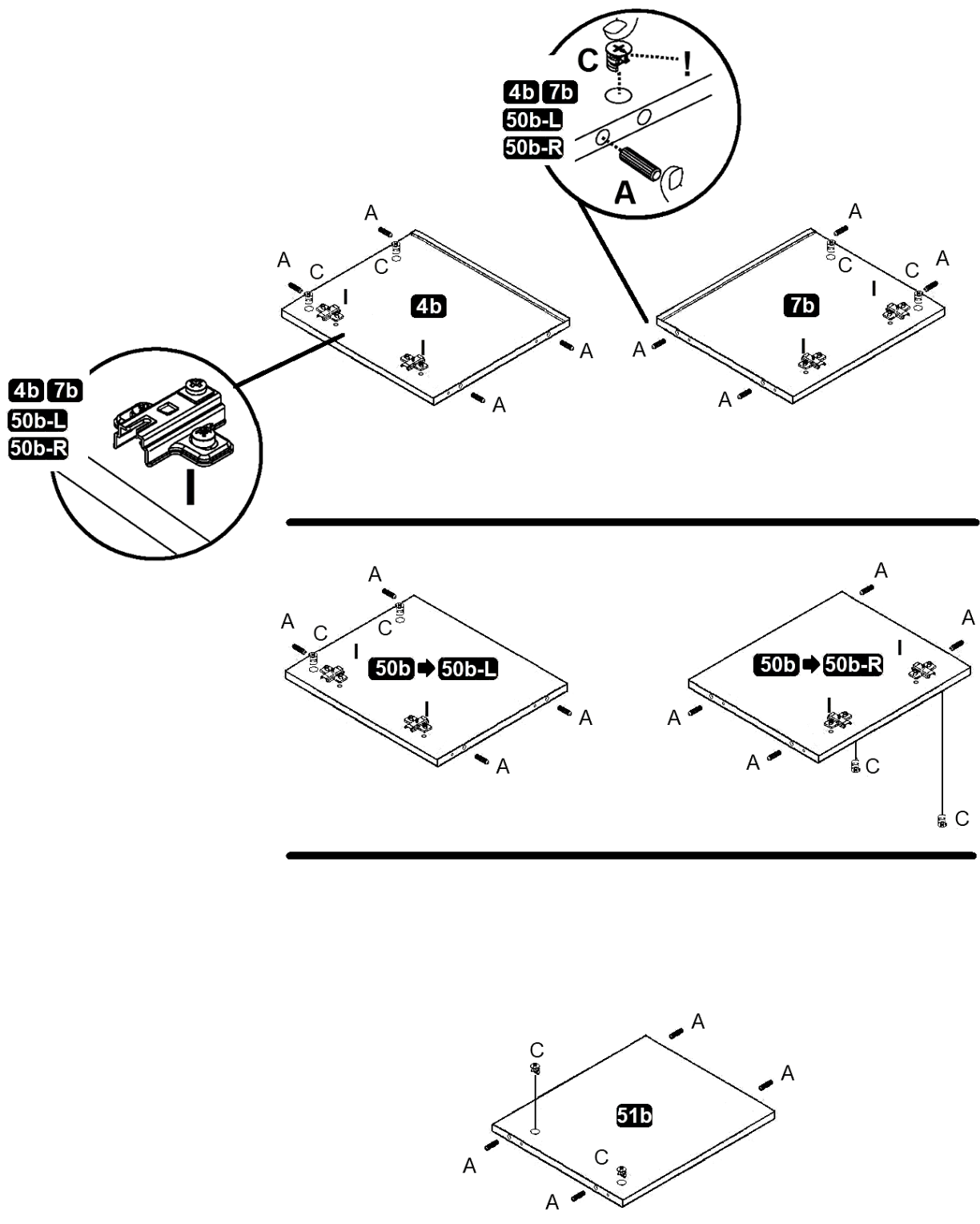
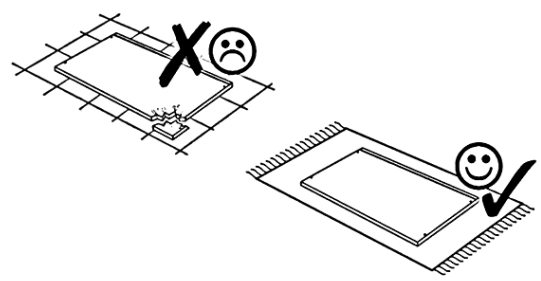

# 3

5,0 x 50 mm  
10x

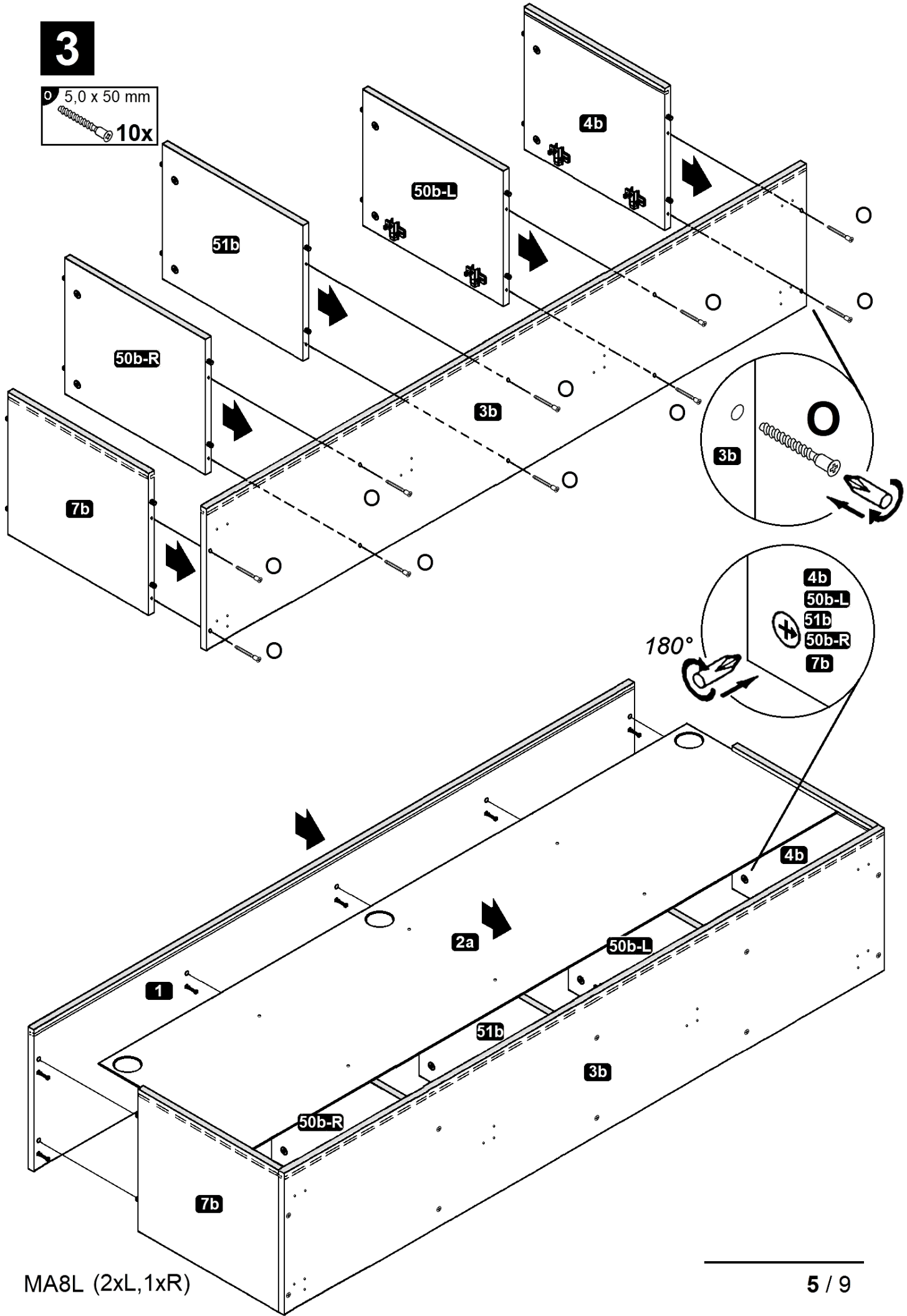

MA8L (2xL, 1xR)

# 4

- K** 2,7 x 20 mm **6x**
- J** **4x**

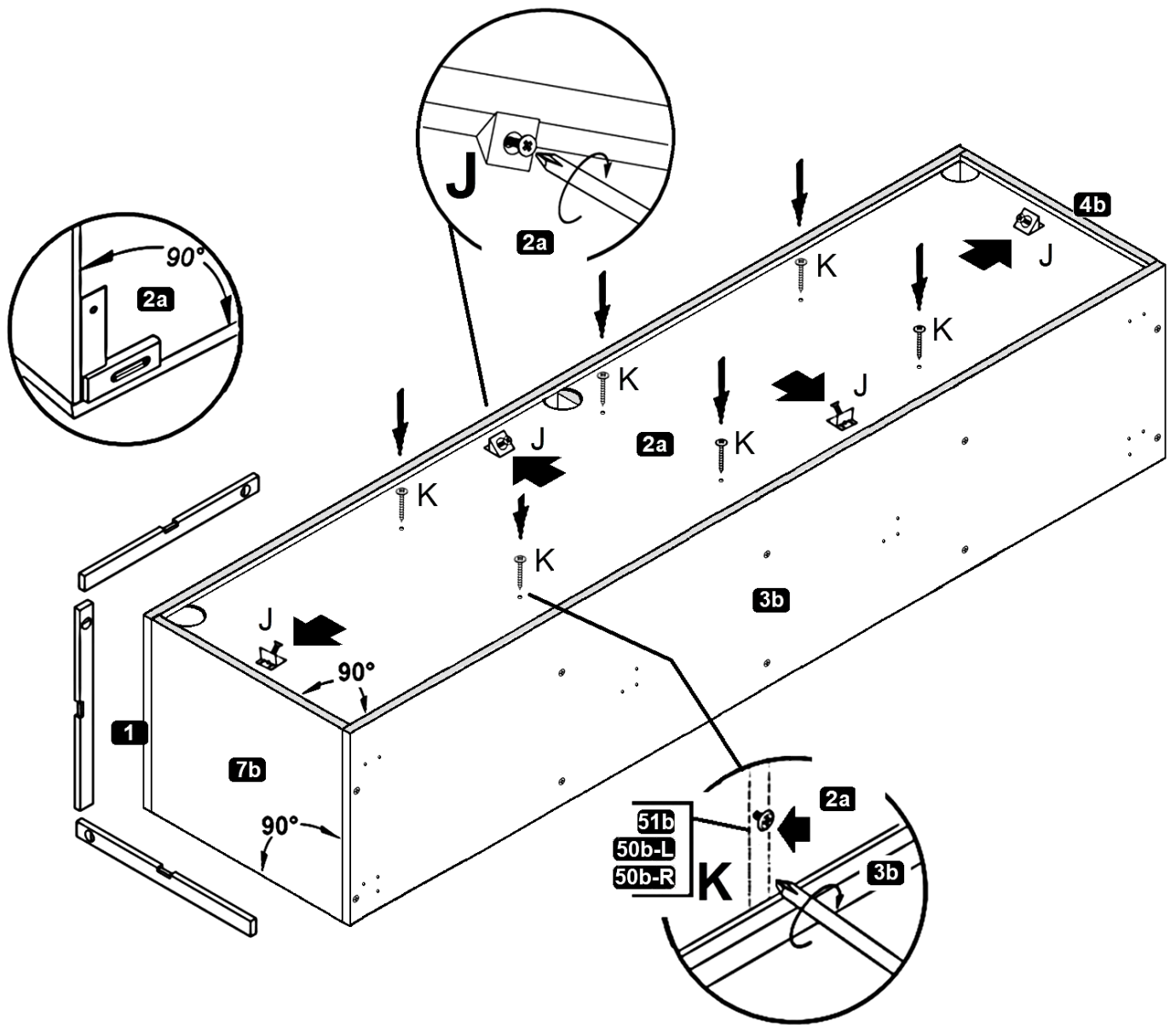

# 5

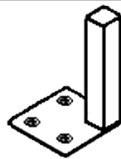

- |  |   |
|--|---|
| (D) <b>Montage der Metallfüße</b>            | (CZ) <b>Montáž kovových nožiček</b>         |
| (GB) <b>Assembly of the metal feet</b>       | (RO) <b>Asamblarea picioarelor metalice</b> |
| (FR) <b>Assemblage des pieds métalliques</b> | (HU) <b>A fém lábak összeszerelése</b>      |
| (IT) <b>Montaggio dei piedini in metallo</b> | (SK) <b>Montáž kovových nožičiek</b>        |
| (NL) <b>Montage van de metalen voetjes</b>   | (TR) <b>Metal ayakların montajı</b>         |
| (PL) <b>Montaż metalowych nóżek</b>          | (RU) <b>Asamblarea picioarelor metalice</b> |

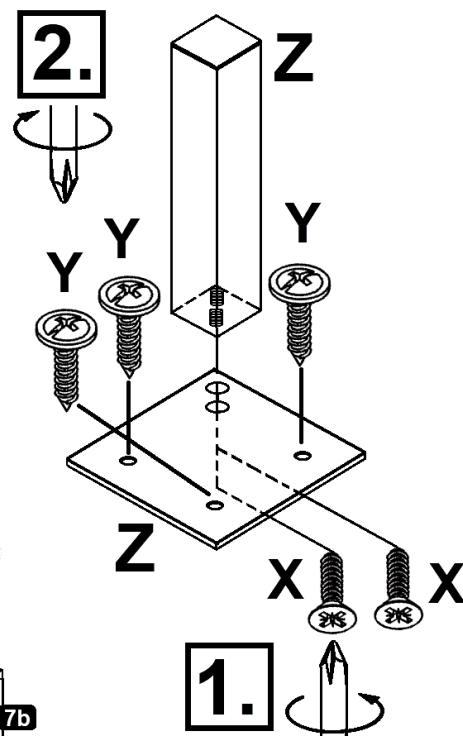
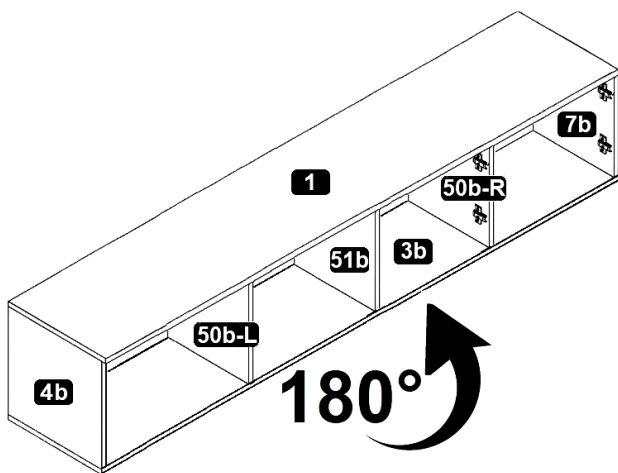

**6**

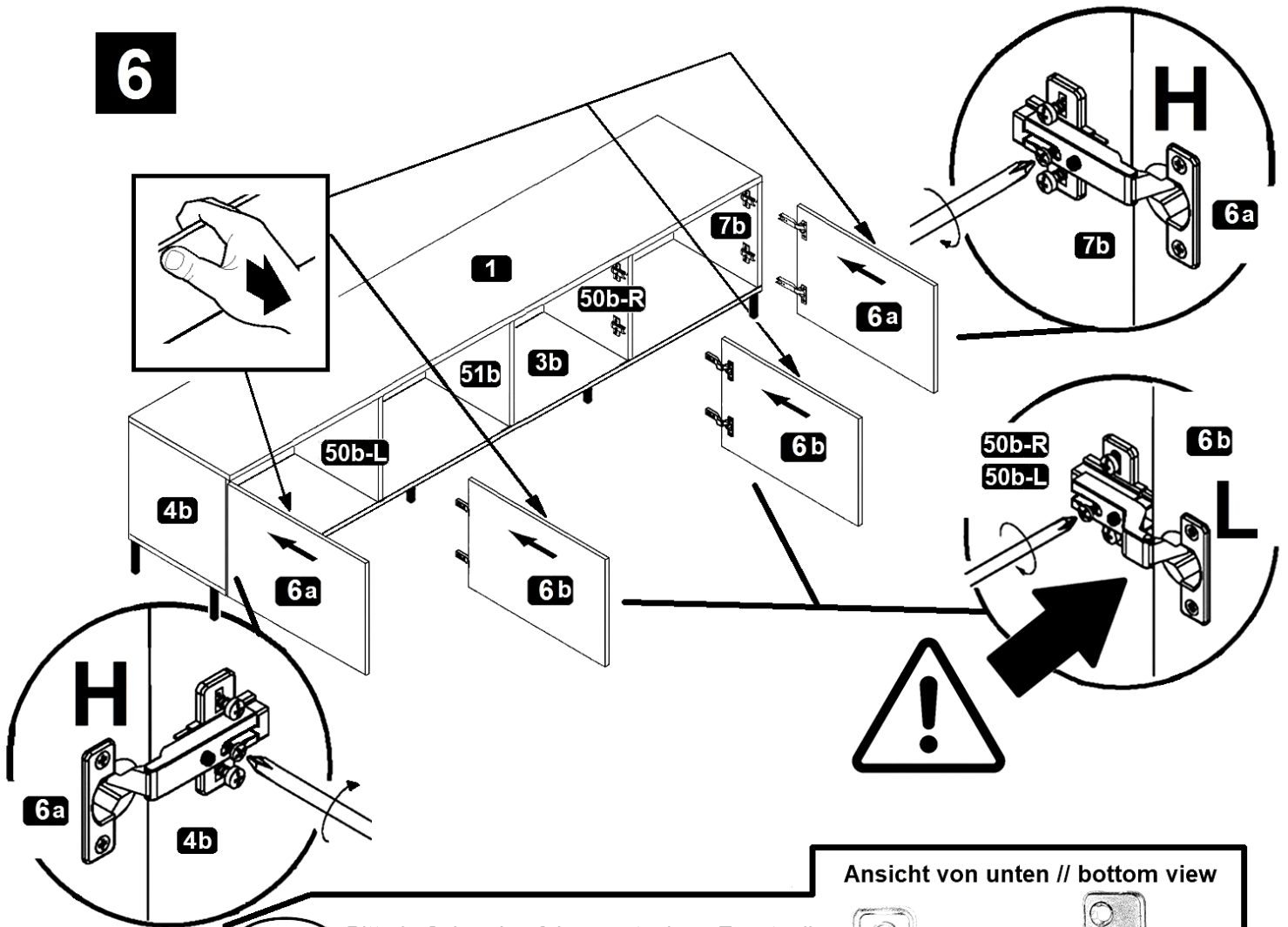

Ansicht von unten // bottom view

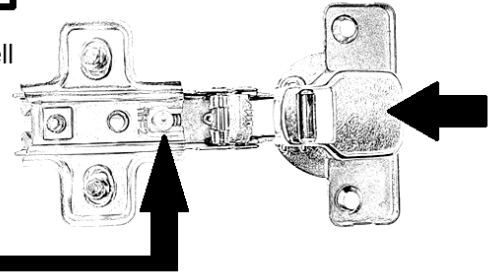

- D** Bitte in Schraubenführung stecken. Eventuell Verstelle schraube leicht herausdrehen.
- GB** Please put in screw guide. If necessary, unscrew the adjusting screw slightly.

**➔ 10 / 10**

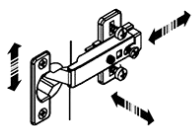

- D** Türen einstellen (Scharniere justieren)
- GB** Adjusting the doors (adjusting the hinges)
- FR** Régler les portes (ajuster les charnières)
- IT** Sistemare le porte (regolare le cerniere)

- NL** Deuren instellen (scharnieren afstellen)
- PL** Nastawić drzwi (wyregulować zawiasy)
- CZ** Vyrovnajte dvířka (seřid'te závěsy)
- RO** Nastavenie dverí (nastavenie závesov)
- HU** Állítsa be az ajtókat (állítsa be a zsanérokot)
- SK** Reglare uši (ajustare balamale)
- TR** Kapıların ayarlanması (menteşelerin seviye ayarı)
- RU** Регулировка дверей (регулировка шарнира)



7

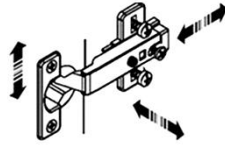

(D) Türen einstellen  
(Scharniere justieren)

(GB) Adjusting the doors  
(adjusting the hinges)

(FR) Régler les portes  
(ajuster les charnières)

(IT) Sistemare le porte  
(regolare le cerniere)

(NL) Deuren instellen  
(scharnieren afstellen)

(PL) Nastawić drzwi  
(wyregulować zawiasy)

(CZ) Vyrovnajte dvířka  
(seřid'te závěsy)

(RO) Nastavenie dverí  
(nastavenie závesov)

(HU) Állítsa be az ajtókat  
(állítsa be a zsanérokat)

(SK) Reglare uši  
(ajustare balamale)

(TR) Kapıların ayarlanması  
(menteşelerin seviye ayarı)

(RU) Регулировка дверей  
(регулировка шарнира)

