



(D) Videounterstützte Montageanleitung

(TR) Video destekli kurulum talimatları

(RU) инструкция по монтажу с помощью видеосигнала

(RO) Instrucțiuni de instalare acceptate video

(GB) Video-assisted assembly instructions

(IT) Istruzioni di montaggio video-assistite

(CZ) Instalační pokyny podporované videem

(PL) Instrukcje montażu wspomagane sygnałem wizyjnym

(FR) Instructions de montage assistées par vidéo

(NL) Video-ondersteunde montage-instructies

(HU) Video-támogatott telepítési utasítások

(SK) Inštaláčn  pokyny podporované videom

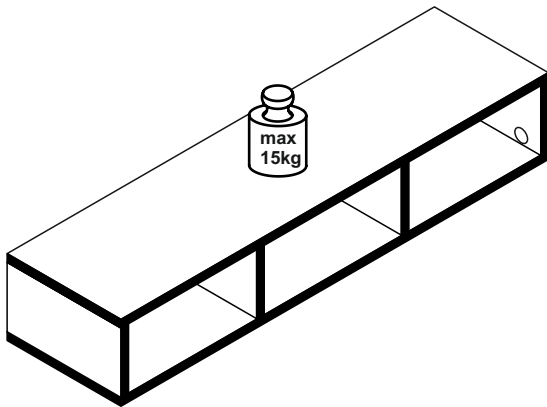
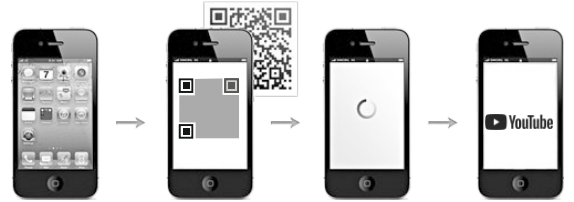

0617-HR_00 Hangeregale





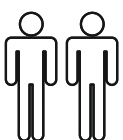
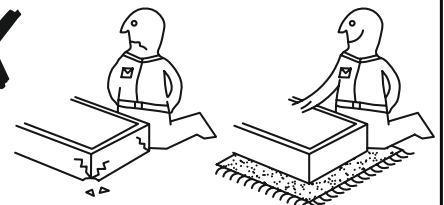
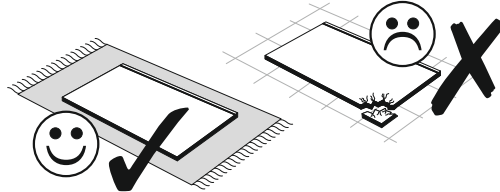
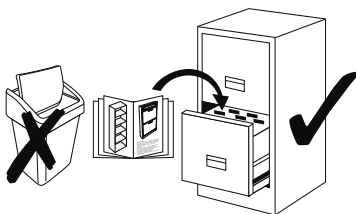
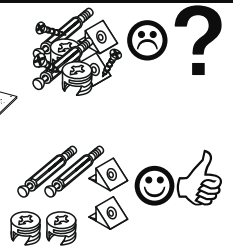
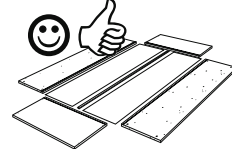
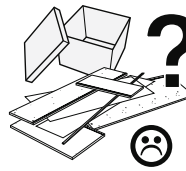
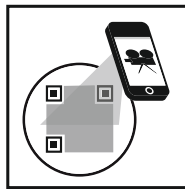
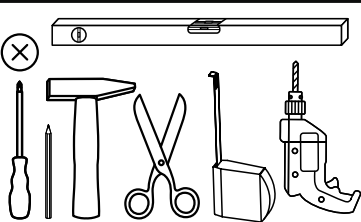

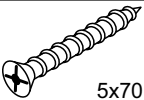

REPC-Nr.:

Service • Assistenza • Dienstverlening • Serwis
Servis • Szerviz • Сервисная служба



Das Ersatzteil-Anforderungsformular finden Sie auf <https://www.maeusbacher.de/ersatzteile/>

BT1-00163 Colli 1/1

B01-177-70		B02-10		B02-20		B02-103	
2x	5x70	14x		14x		8x	8x30
B05-01		B05-20		B05-130		B08-70	
2x		8x		2x		2x	Ø8

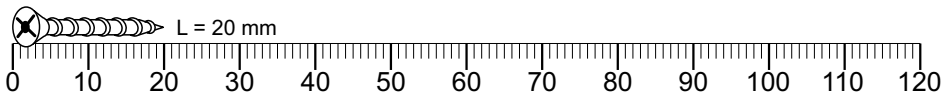
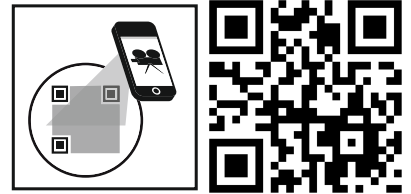

Colli 1/1

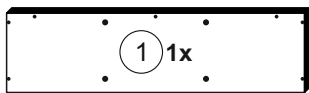

1182 x 315
FTx-000263

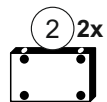

192 x 315
FTx-000266

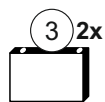

192 x 291
FTx-000264

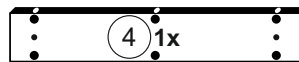

1151 x 192
FTx-000265

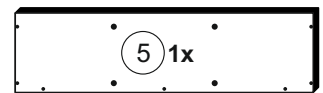

1182 x 315
FTx-000263

1

B02-20	
7x	

①

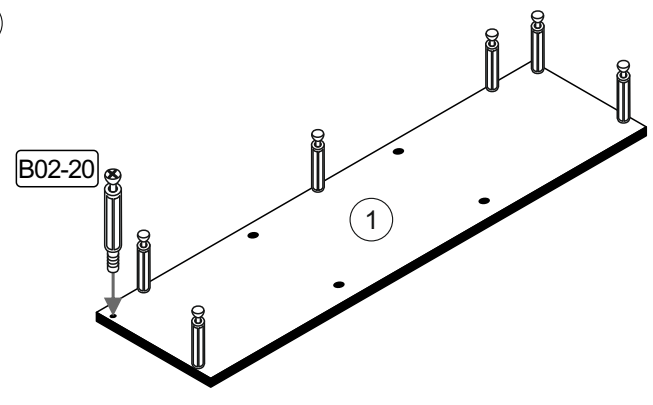
2

B02-10	
8x	

②

3

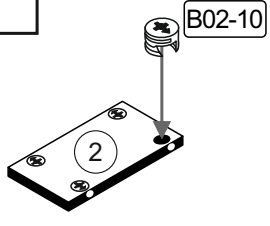
B02-103	
8x	8x30
B05-130	
1x	

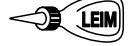
③

4

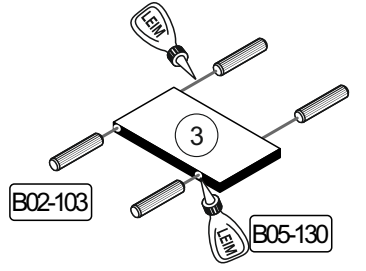
B02-10	
6x	

④

5

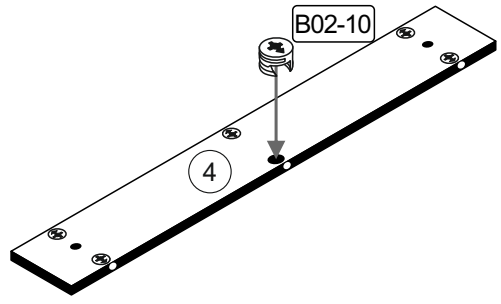
B02-20	
7x	

⑤



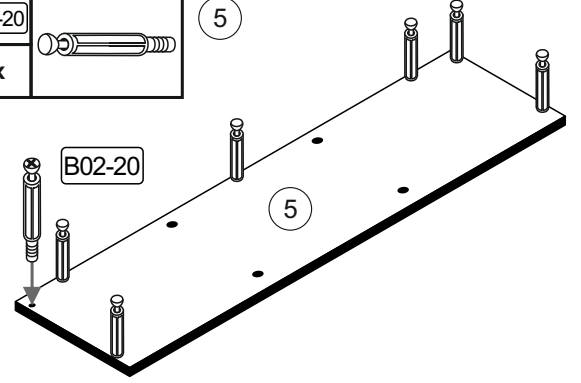

6

B05-130	
1x	

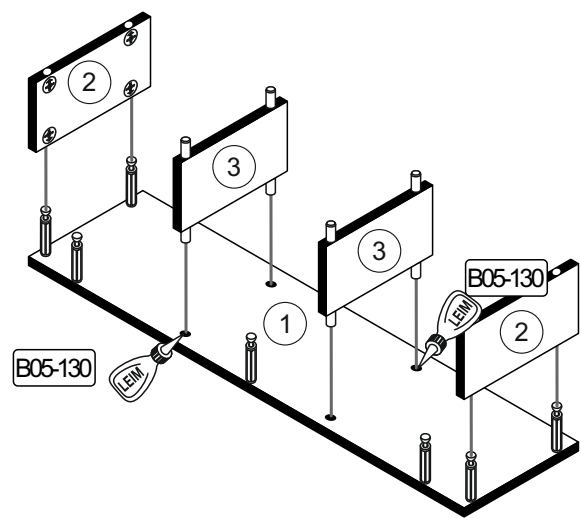
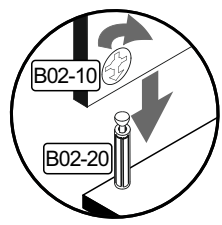
① ② ③

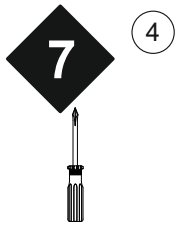

4

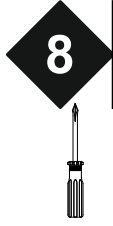
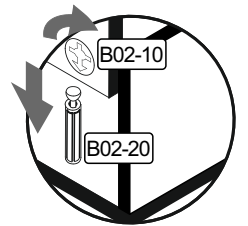
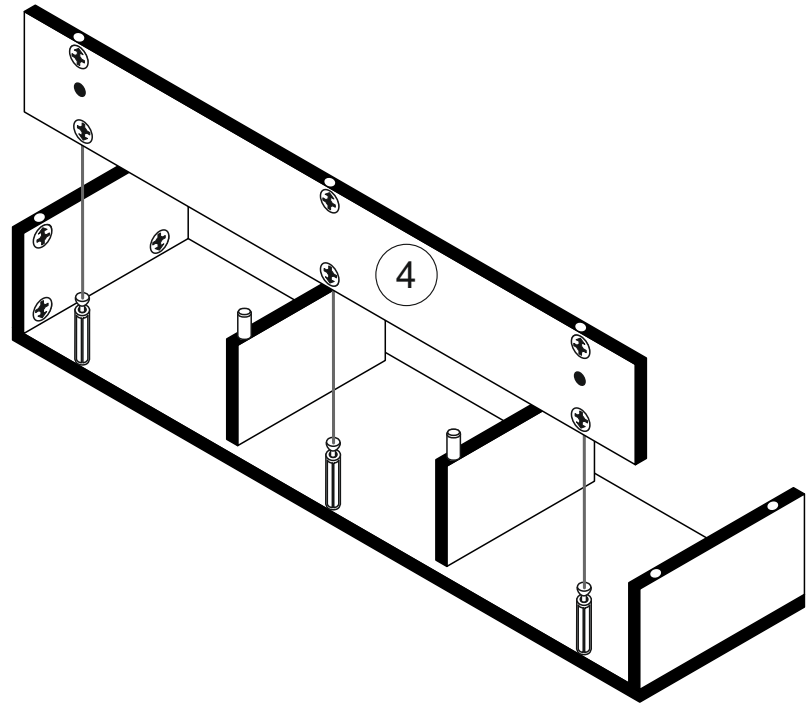

B05-130		B05-20	
1x		8x	

5

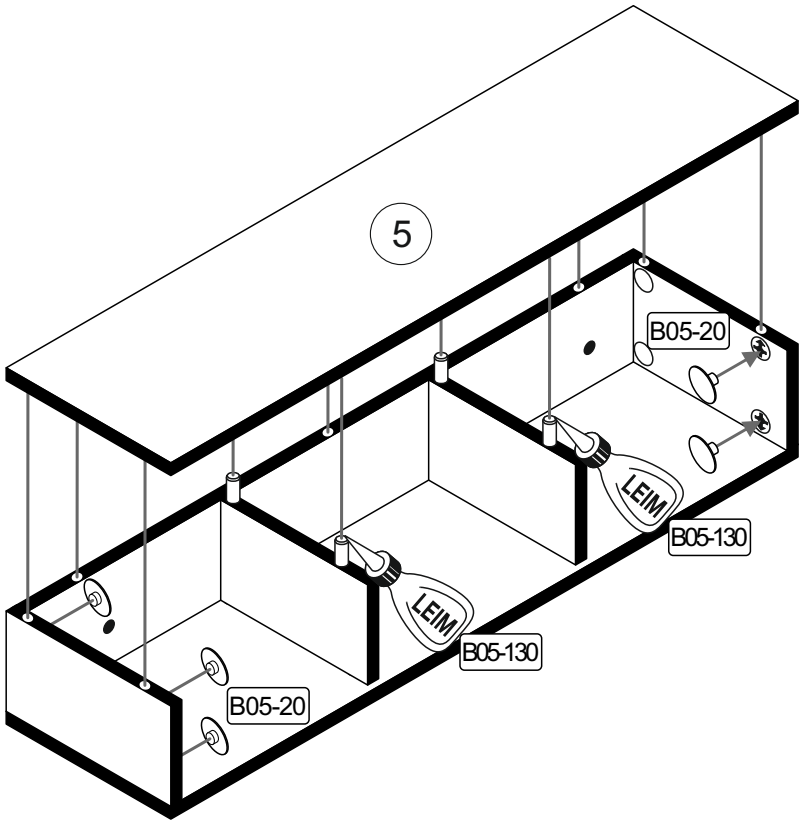



B05-01		B01-177-70		B08-70	
2x		2x	5x70	2x	Ø8

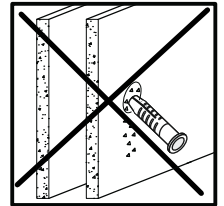
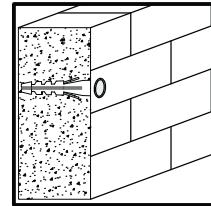
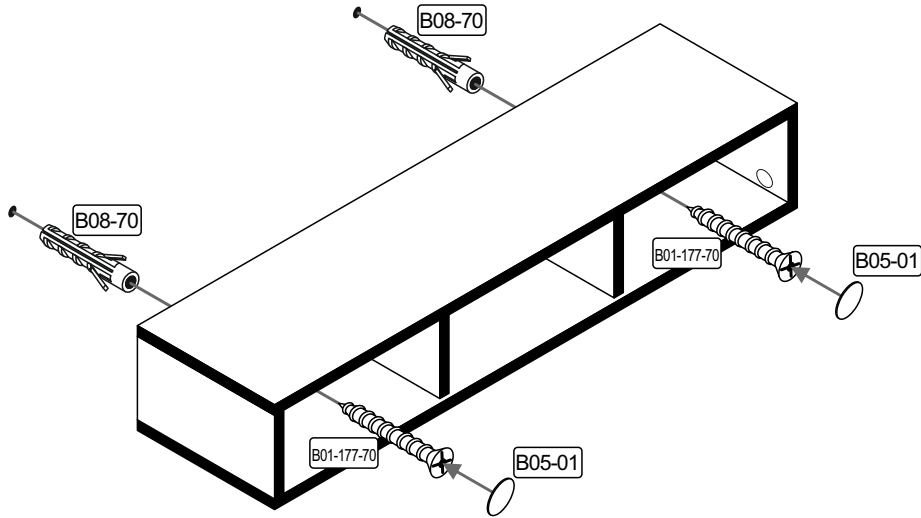

Achtung • Attention • Attenzione • Opgelet • Uwaga • Pozor • Figyelem • Atenție • Dikkat • Внимание	
(D)	Wandbefestigung dient als Kippschutz - unbedingt anbringen! Bei einigen Wandtypen kann ein Spezialdübel erforderlich sein!
(GB)	The wall fastening serves to prevent tipping - be absolutely sure to mount it! For certain wall types, a special wall plug may be necessary!
(FR)	La fixation murale sert de protection contre le basculement – à installer impérativement ! Pour certains types de murs il faut des chevilles spéciales !
(TR)	Duvardaki sabitleme, devrilmeye karşı bir emniyet tedbiridir ve mutlaka monte edilmelidir! Bazı duvar tiplerinde bunun için özel bir dübel gerekli olabilir!
(IT)	Il fissaggio alla parete serve da protezione anti-ribaltamento – attaccarla assolutamente! Per alcune strutture di parete può essere necessario un tassello speciale!
(NL)	Bevestiging aan de muur dient als kantelbescherming – zeker en vast bevestigen! Bij enkele muurtypes is een speciale plug misschien vereist!
(RU)	Обязательно установите крепление на стене во избежание опрокидывания! Для некоторых типов стен может потребоваться специальный дюбель!
(CZ)	Montáž na stěnu slouží jako ochrana proti převrnutí – bezpodmínečně umístěte! U některých typů stěn může být zapotřebí speciální hmoždinka!
(HU)	A terméket a falhoz kel rögzíteni, különben az felborulhat! Egyes faltípusoknál speciális tiplít kell használni!
(RO)	Sistemul de fixare la perete servește ca protecție la răsturnare - de montat obligatoriu! Pentru unele tipuri de pereți este posibil să fie necesar un diblu special!
(PL)	Mocowanie do ściany jest jednocześnie zabezpieczeniem przed przewróceniem – koniecznie zamontować! Do niektórych rodzajów ścian koniecznie zastosować specjalne kołki mocujące.
(SK)	Upevnenie na stenu slúži ako ochrana proti prevráteniu – bezpodmienečne použiť! Pre niektoré druhy stien môže byť potrebná špeciálna hmoždinka!

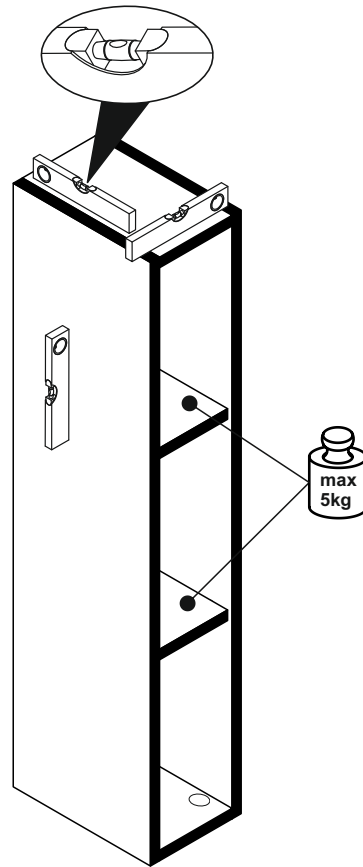
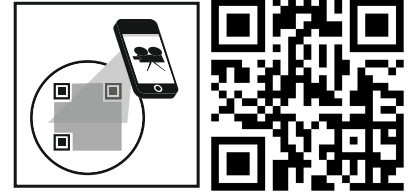

vertikale Aufhängung

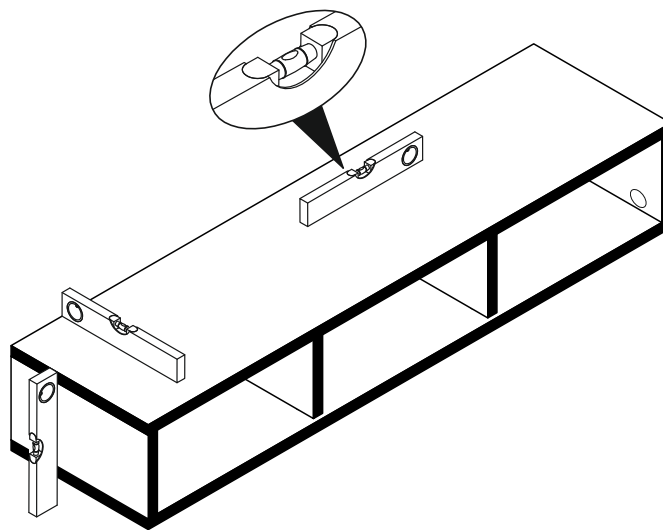

horizontale Aufhängung



(D) Videounterstützte Montageanleitung

(TR) Video destekli kurulum talimatları

(RU) инструкция по монтажу с помощью видеосигнала

(RO) Instrucțiuni de instalare acceptate video

(GB) Video-assisted assembly instructions

(IT) Istruzioni di montaggio video-assistite

(CZ) Instalační pokyny podporované videem

(PL) Instrukcje montażu wspomagane sygnałem wizyjnym

(FR) Instructions de montage assistées par vidéo

(NL) Video-ondersteunde montage-instructies

(HU) Video-támogatott telepítési utasítások

(SK) Inštaláčn  pokyny podporované videom

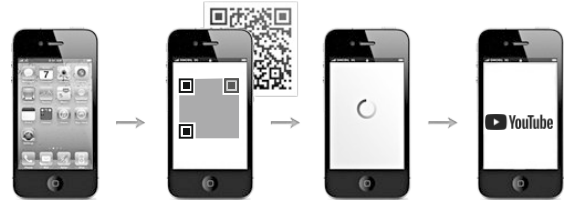
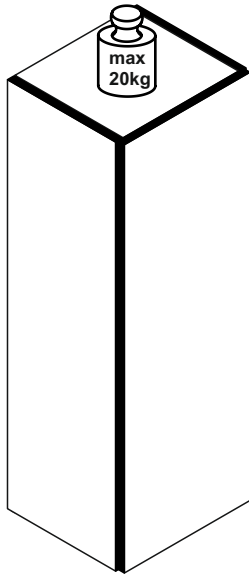

0617-HS_1

REPC-Nr.:





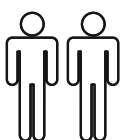
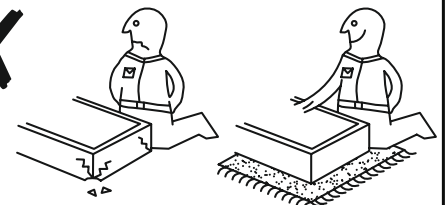
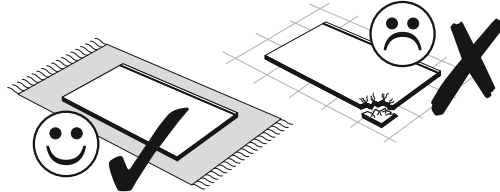
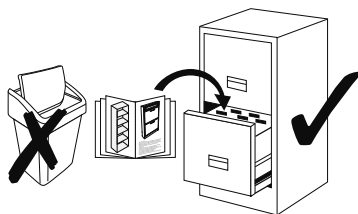
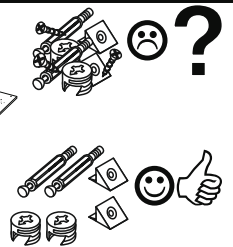
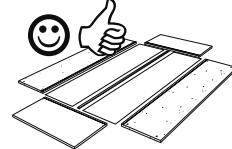
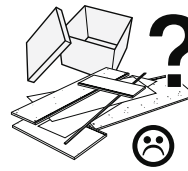
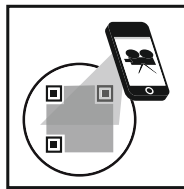
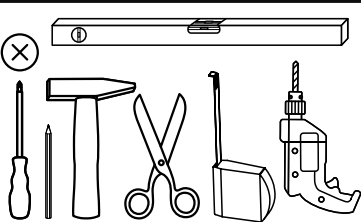



Hngeschrank senkrecht

Service • Assistenza • Dienstverlening • Serwis
Servis • Szerviz • Сервисная служба



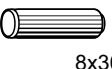

Das Ersatzteil-Anforderungsformular finden Sie auf <https://www.maeusbacher.de/ersatzteile/>

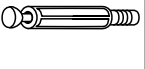
BT1-00171 Colli 1/1

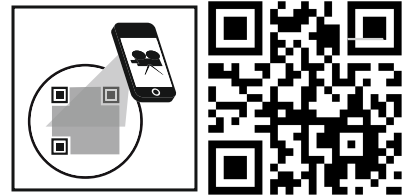



B01-30		B01-90		B01-80	
8x	3x16	4x	3.5x20	11x	3.5x13
B01-330		B08-70		B08-40	
2x	M4x10	2x	Ø8	2x	5.8x65
B02-103		B02-10		B02-20	
8x	8x30	8x		8x	

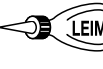

BT1-00172 Colli 1/1

B03-11		B03-41		B03-07	
3x		3x	0er	1x	

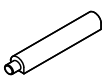
BT1-00173 Colli 1/1

B05-185		B05-130		B01-351	
4x		1x	LEIM	2x	M4
B03-148		B03-149		B03-150	
1x		1x		1x	
				B03-157	Push
				1x	

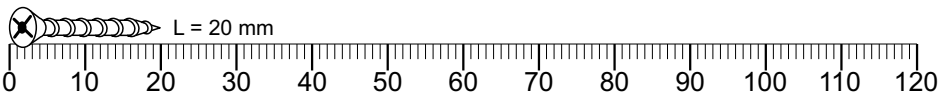

Colli 1/1

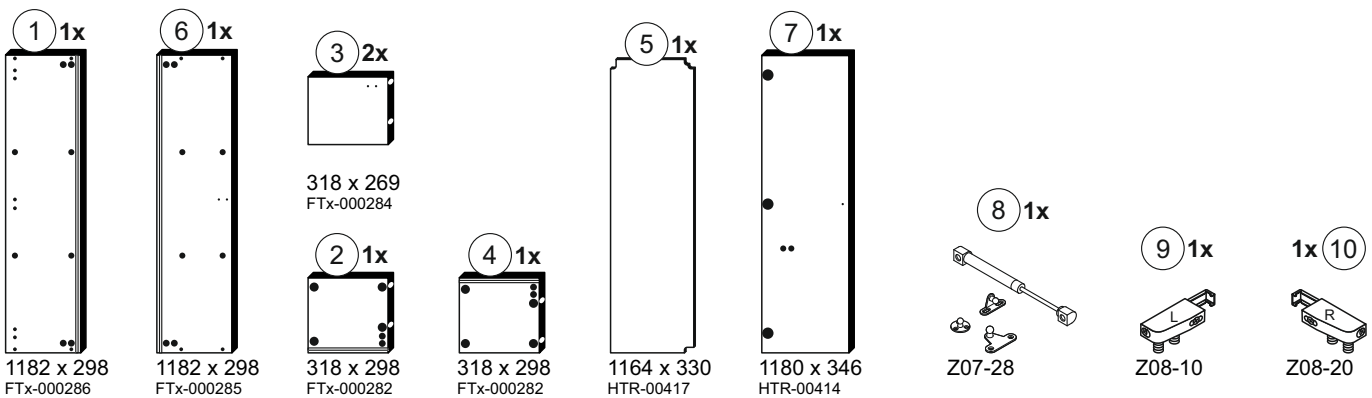

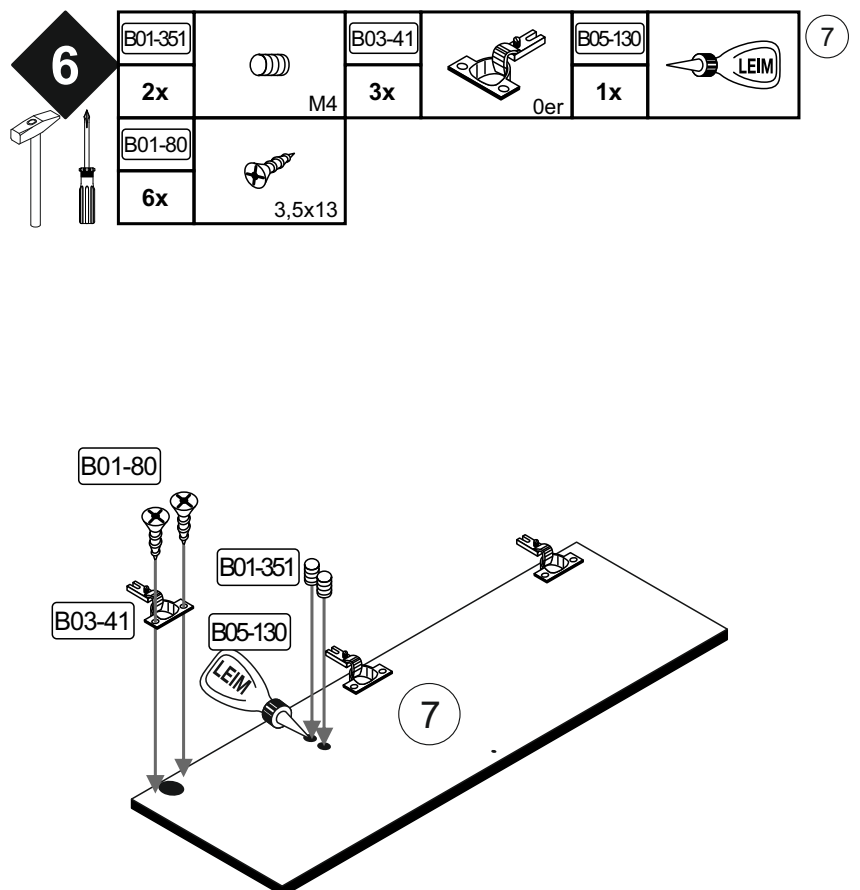
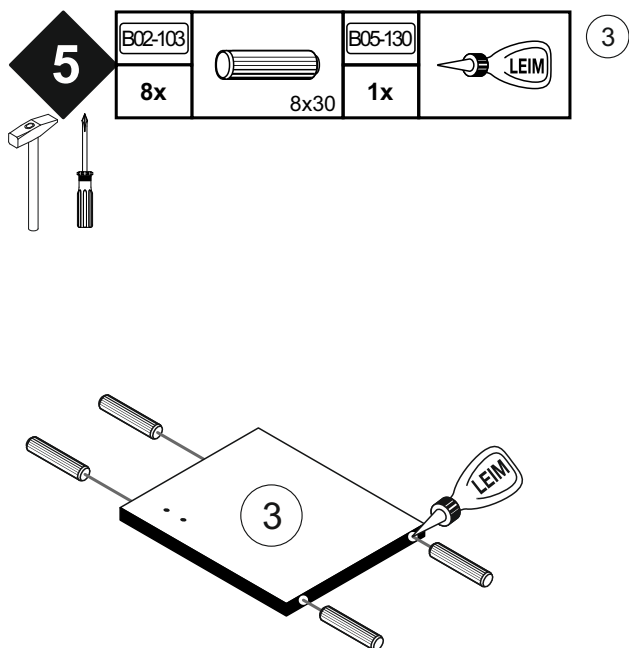
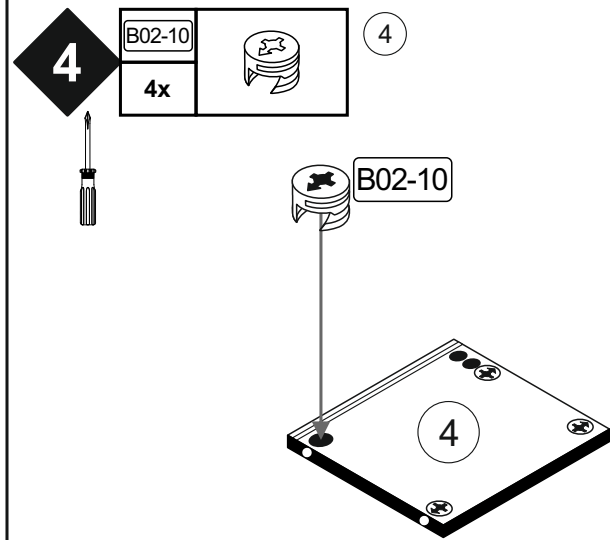
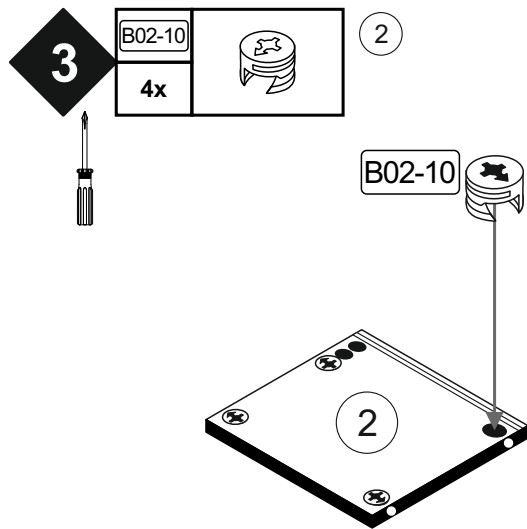
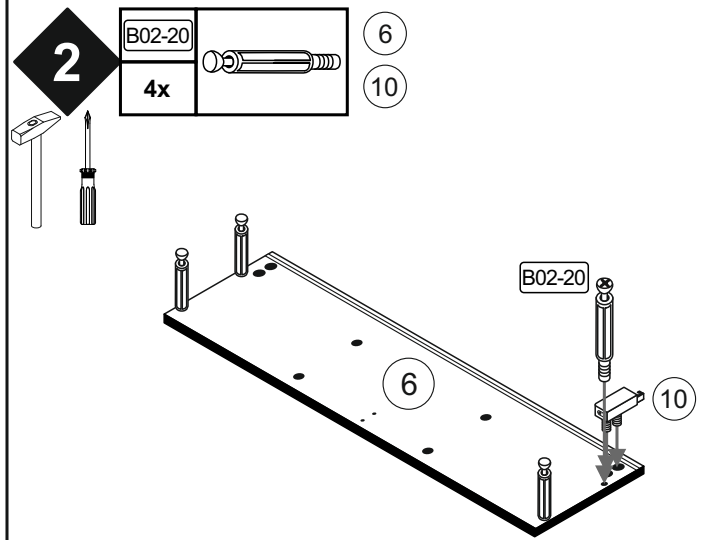
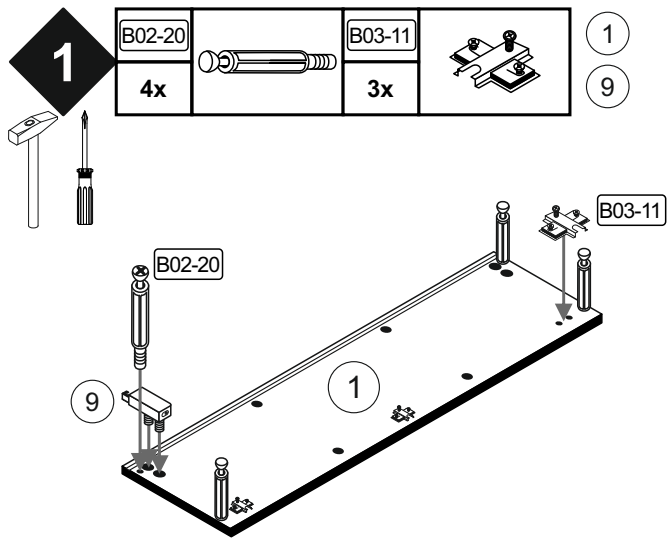

7

B05-130		2	3
1x		4	6

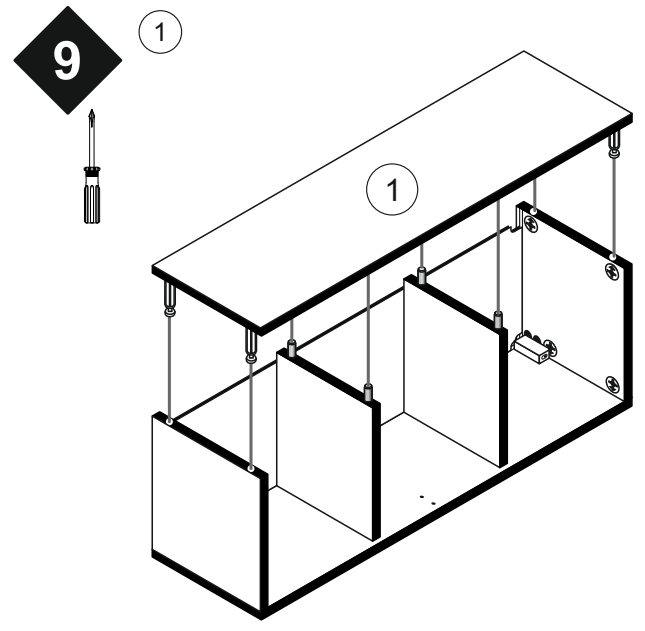
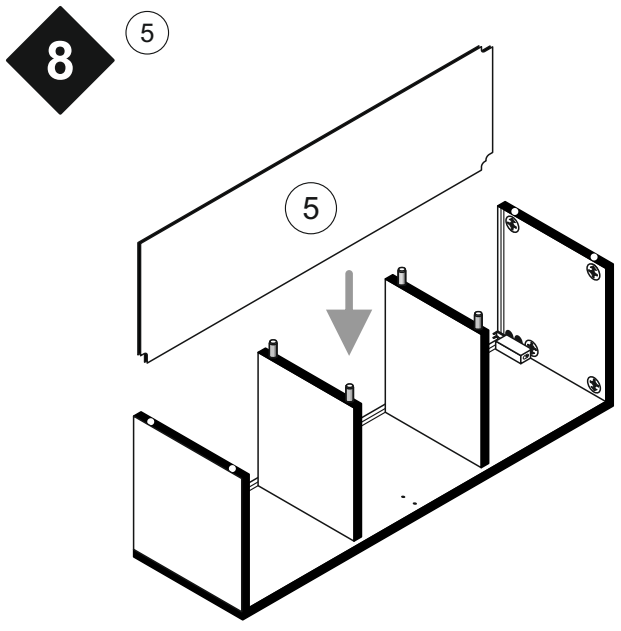
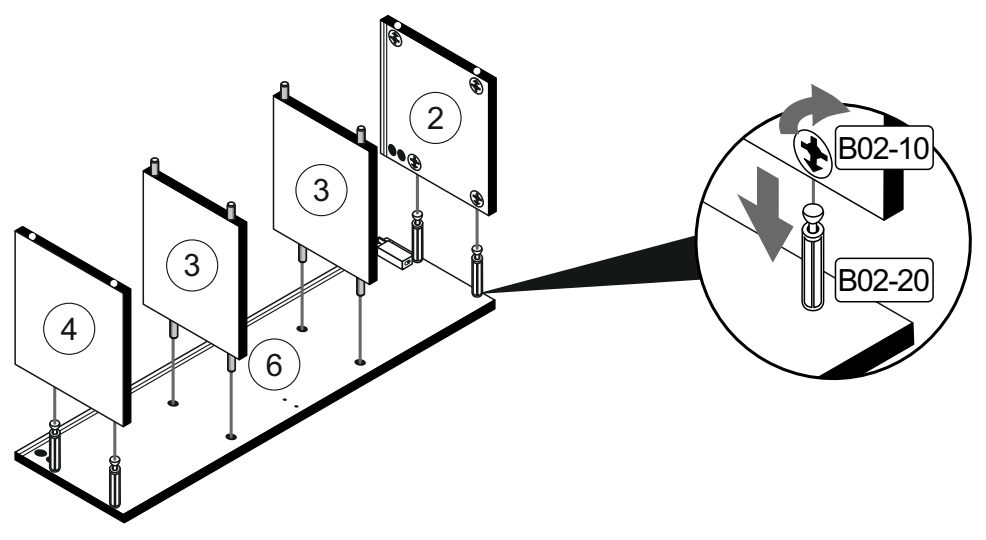

10



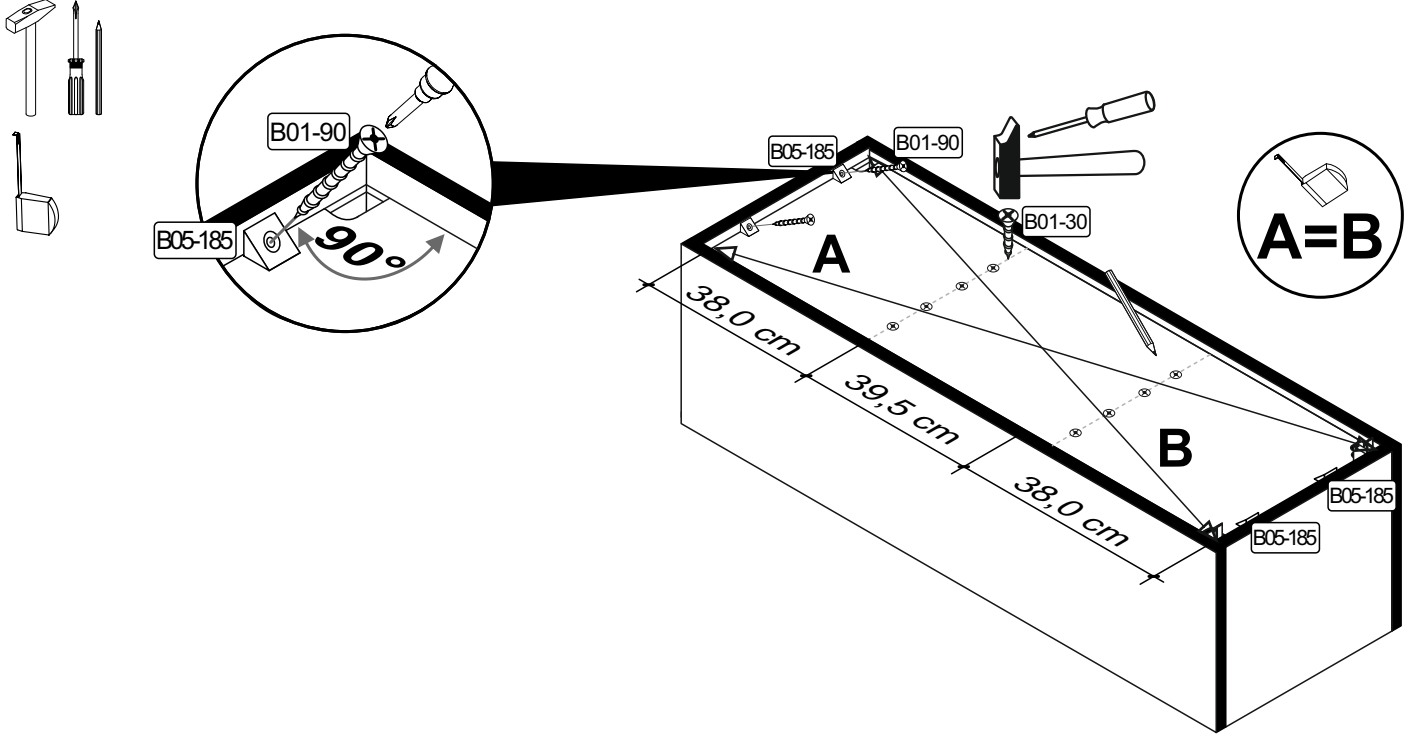

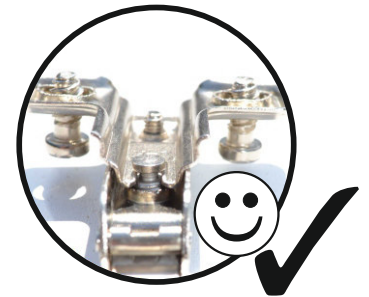
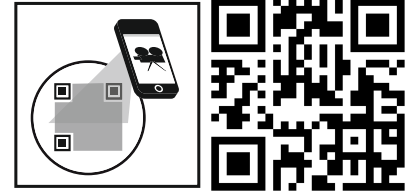
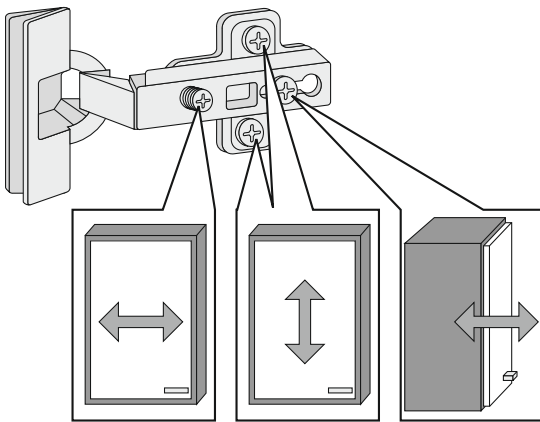
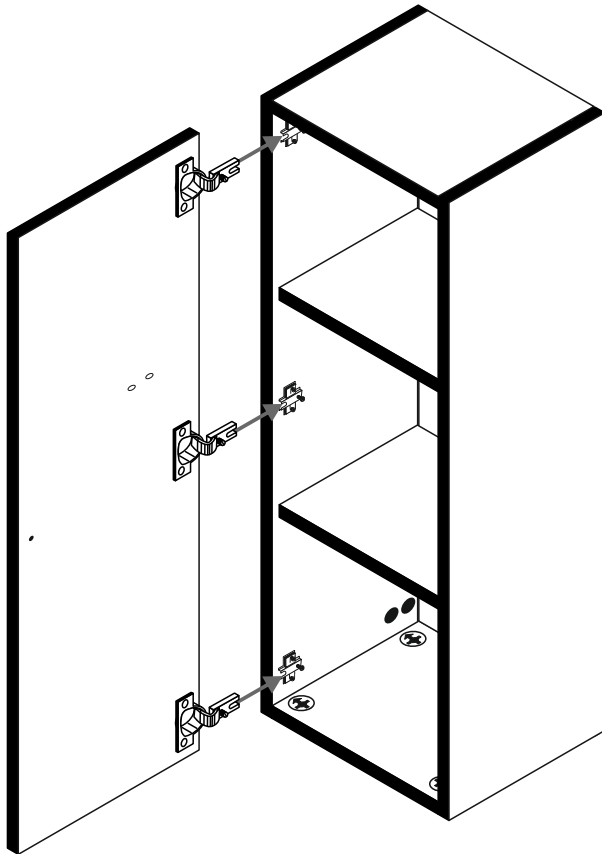
B01-30		B05-185		B01-90	
8x	3x16	4x		4x	3,5x20





Türen einstellen (Scharniere justieren)
 Adjusting the doors (adjusting the hinges)
Régler les portes (ajuster les charnières)
 Sistemare le porte (regolare le cerniere)
Deuren instellen (scharnieren afstellen)
 Nastawić drzwi (wyregulować zawiasy)
Vyrovnejte dvířka (seřid'ťe závěsy)
 Nastavenie dverí (nastavenie závesov)
Állítsa be az ajtókat (állítsa be a zsanérokot)
 Reglare uși (ajustare balamale)
Капиларин аярланмасы (ментешелерин seviye аяры)
 Регулировка дверей (регулировка шарнира)

12

B01-80		B03-148		B03-149		B03-150		B03-157	Push
3x	3,5x13	1x		1x		1x		1x	
B03-07									
1x									

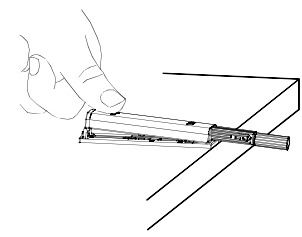

Bitte beachten:

- 3-149 mit 1-80 an der Seite befestigen
- 3-148 seitlich eindrücken
- 3-150 auf 3-148 heften
- 3-150 Schutzfolie entfernen
- Klappe schließen

Montage der Türdämpfung

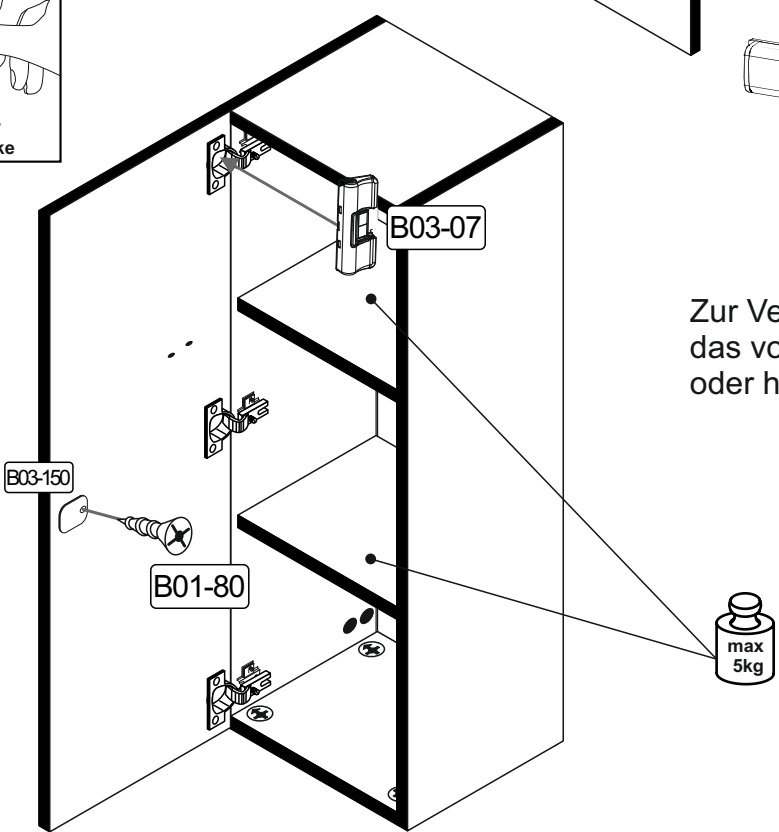
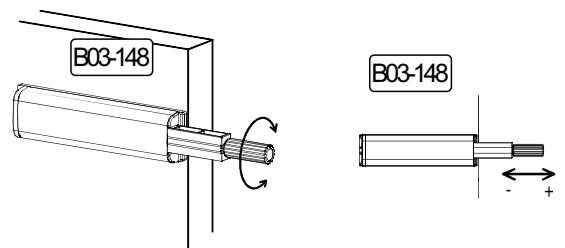
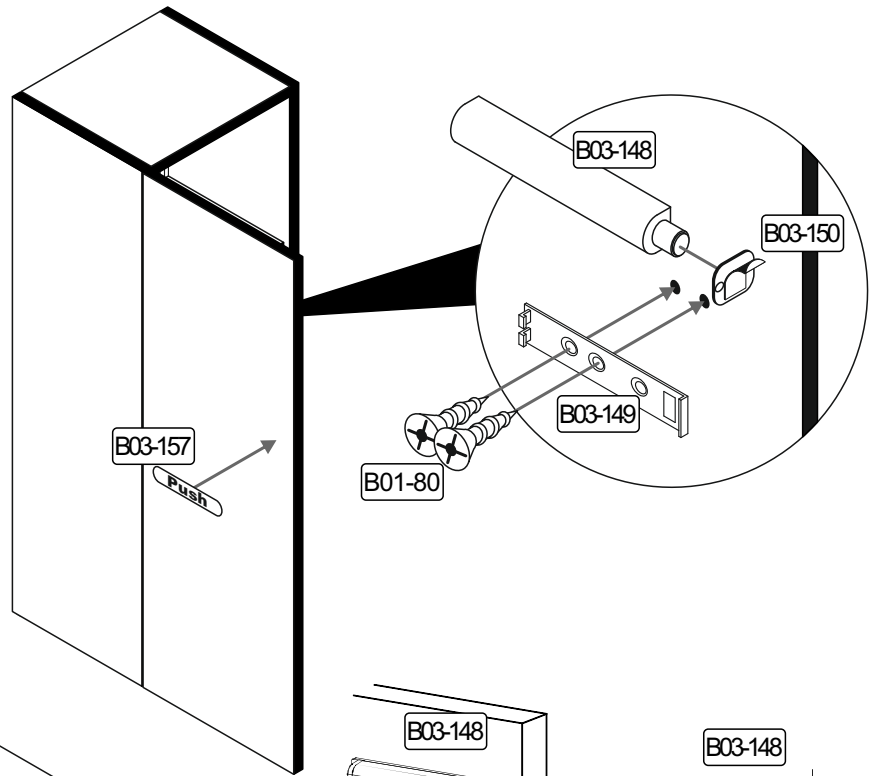
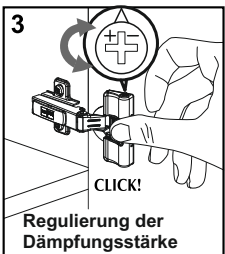
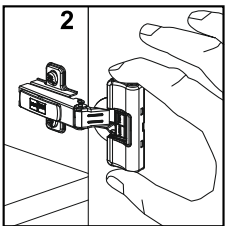
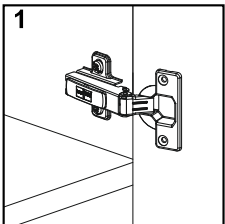

Zur Verstärkung oder Minderung des Hubes das vordere Stück des Beschlages hinein oder heraus drehen

13	B08-40		B08-70	
	2x	5,8x65	2x	Ø8

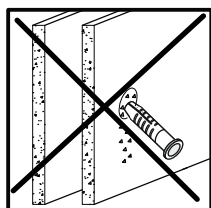
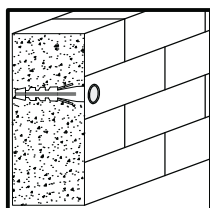
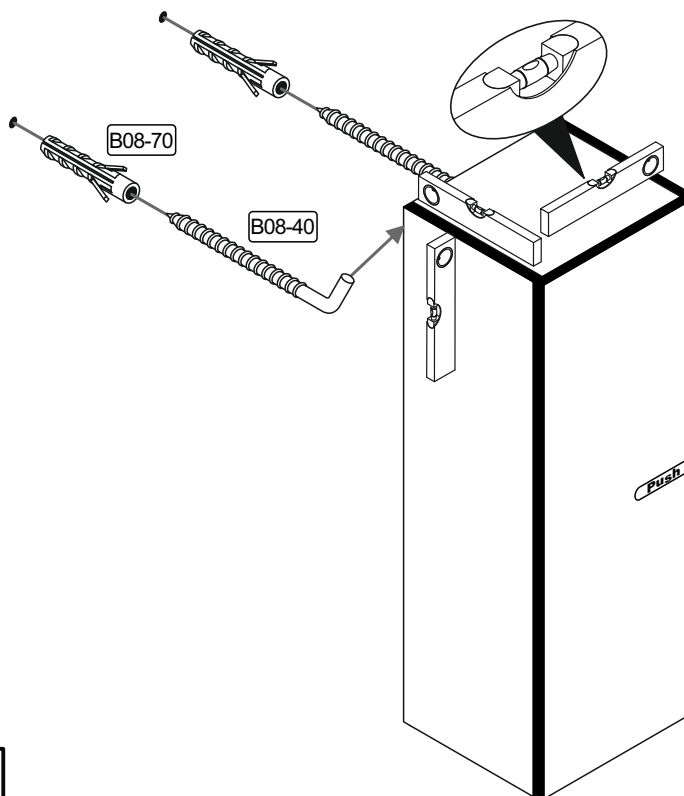
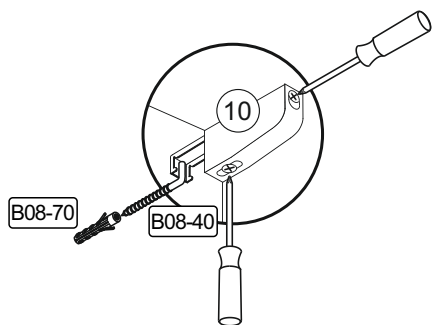

Achtung • Attention • Attenzione • Opgelet • Uwaga • Pozor • Figyelem • Atenție • Dikkat • Внимание	
(D)	Wandbefestigung dient als Kippschutz - unbedingt anbringen! Bei einigen Wandtypen kann ein Spezialdübel erforderlich sein!
(GB)	The wall fastening serves to prevent tipping - be absolutely sure to mount it! For certain wall types, a special wall plug may be necessary!
(FR)	La fixation murale sert de protection contre le basculement – à installer impérativement ! Pour certains types de murs il faut des chevilles spéciales !
(TR)	Duvardaki sabitleme, devrilmeye karşı bir emniyet tedbiridir ve mutlaka monte edilmelidir! Bazı duvar tiplerinde bunun için özel bir dübel gerekli olabilir!
(IT)	Il fissaggio alla parete serve da protezione anti-ribaltamento – attaccarla assolutamente! Per alcune strutture di parete può essere necessario un tassello speciale!
(NL)	Bevestiging aan de muur dient als kantelbescherming – zeker en vast bevestigen! Bij enkele muurtypes is een speciale plug misschien vereist!
(RU)	Обязательно установите крепление на стене во избежание опрокидывания! Для некоторых типов стен может потребоваться специальный дюбель!
(CZ)	Montáž na stěnu slouží jako ochrana proti převrnutí – bezpodmínečně umístěte! U některých typů stěn může být zapotřebí speciální hmoždinka!
(HU)	A terméket a falhoz kel rögzíteni, különben az felborulhat! Egyes faltípusoknál speciális tiplit kell használni!
(RO)	Sistemul de fixare la perete servește ca protecție la răsturnare - de montat obligatoriu! Pentru unele tipuri de pereți este posibil să fie necesar un diblu special!
(PL)	Mocowanie do ściany jest jednocześnie zabezpieczeniem przed przewróceniem – koniecznie zamontować! Do niektórych rodzajów ścian koniecznie zastosować specjalne kołki mocujące.
(SK)	Upevnenie na stenu slúži ako ochrana proti prevráteniu – bezpodmienečne použite! Pre niektoré druhy stien môže byť potrebná špeciálna hmoždinka!



(D) Videounterstützte Montageanleitung

(TR) Video destekli kurulum talimatları

(RU) инструкция по монтажу с помощью видеосигнала

(RO) Instrucțiuni de instalare acceptate video

(GB) Video-assisted assembly instructions

(IT) Istruzioni di montaggio video-assistite

(CZ) Instalační pokyny podporované videem

(PL) Instrukcje montażu wspomagane sygnałem wizyjnym

(FR) Instructions de montage assistées par vidéo

(NL) Video-ondersteunde montage-instructies

(HU) Video-támogatott telepítési utasítások

(SK) Inštaláčne pokyny podporované videom

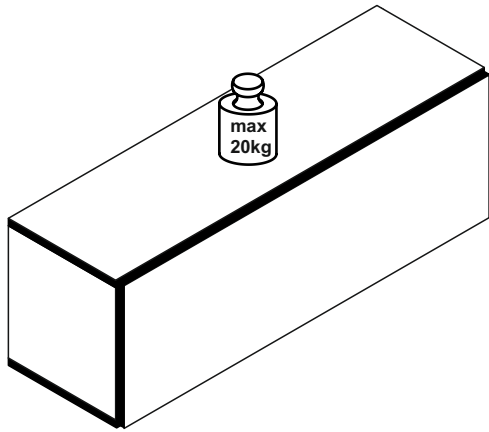
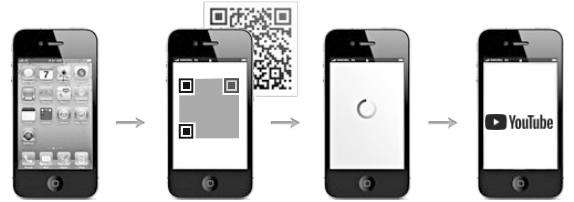

0617-HS_1

REPC-Nr.:





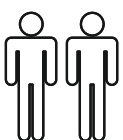
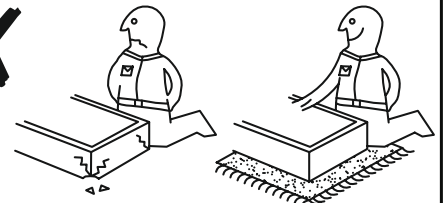
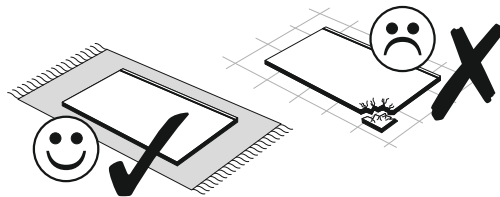
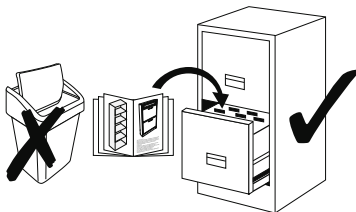
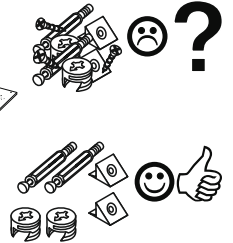
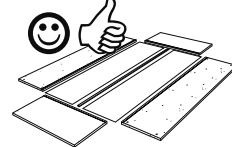
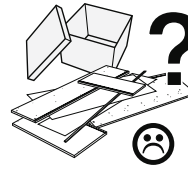
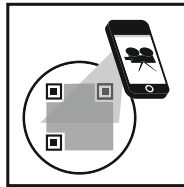
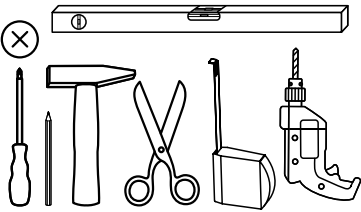



Hängeschrank waagrecht

Service • Assistenza • Dienstverlening • Serwis
Servis • Szerviz • Сервисная служба



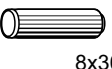

Das Ersatzteil-Anforderungsformular finden Sie auf <https://www.maeusbacher.de/ersatzteile/>

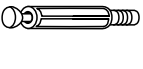
BT1-00171 Colli 1/1

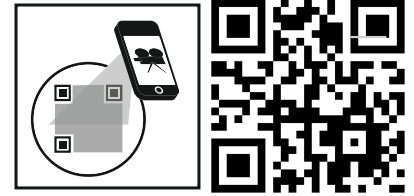



B01-30		B01-90		B01-80	
8x	3x16	4x	3.5x20	11x	3.5x13
B01-330		B08-70		B08-40	
2x	M4x10	2x	Ø8	2x	5.8x65
B02-103		B02-10		B02-20	
8x	8x30	8x		8x	

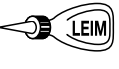

BT1-00172 Colli 1/1

B03-11		B03-41		B03-07	
3x		3x	0er	1x	

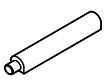
BT1-00173 Colli 1/1

B05-185		B05-130		B01-351	
4x		1x	LEIM	2x	M4
B03-148		B03-149		B03-150	
1x		1x		1x	
				B03-157	Push
				1x	

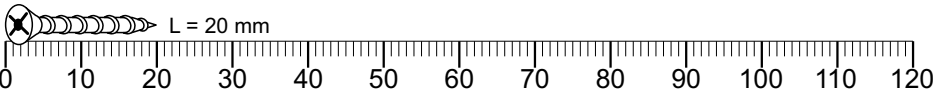

Colli 1/1

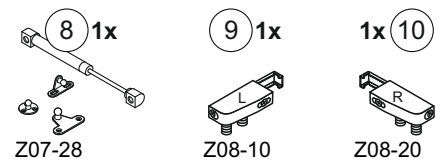
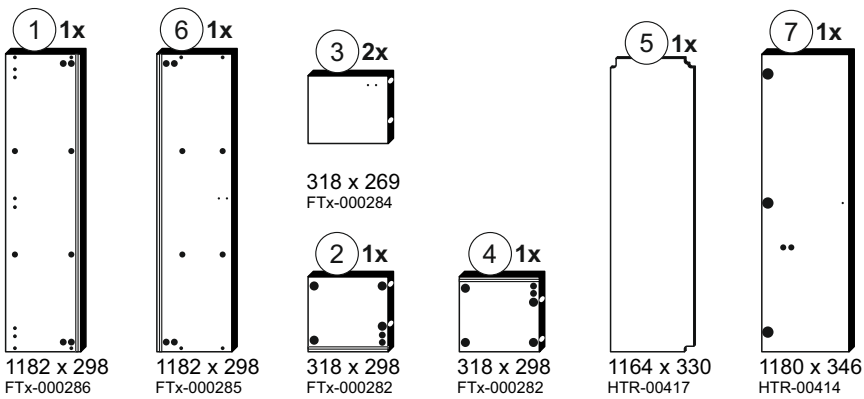

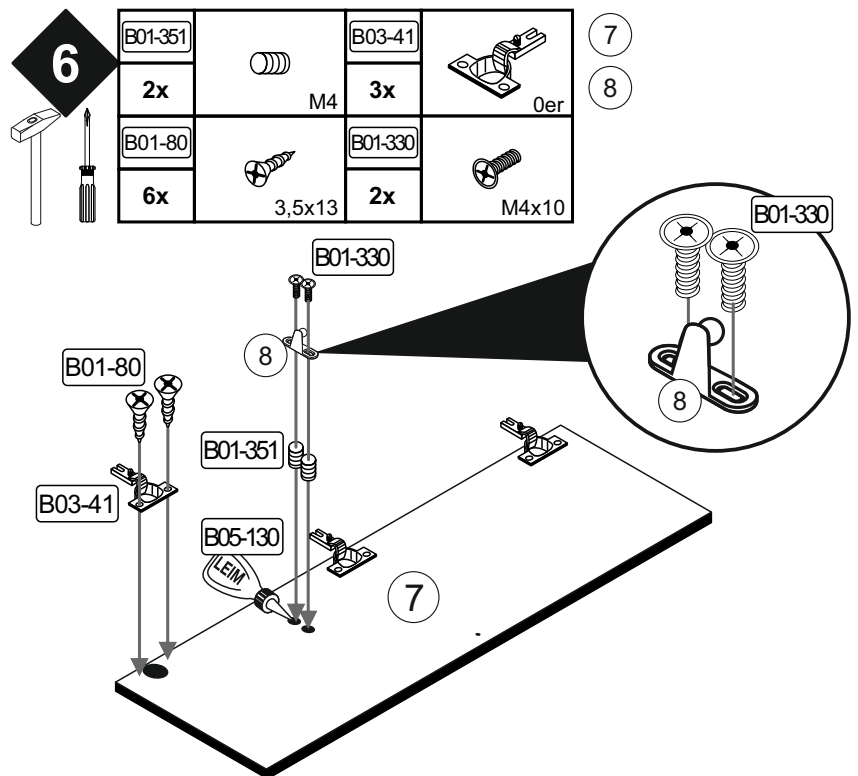
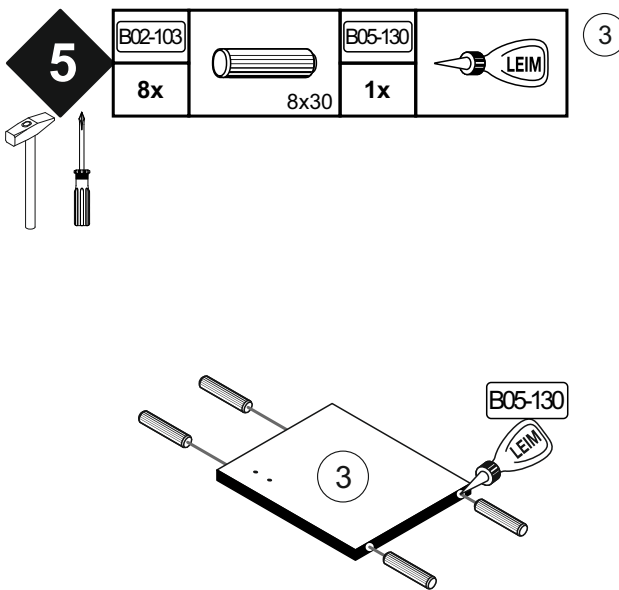
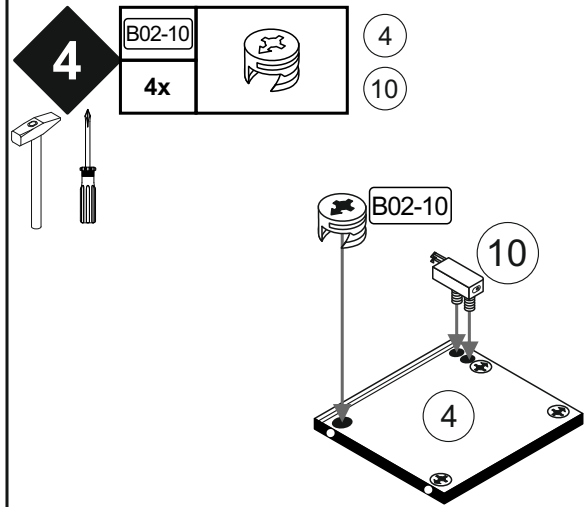
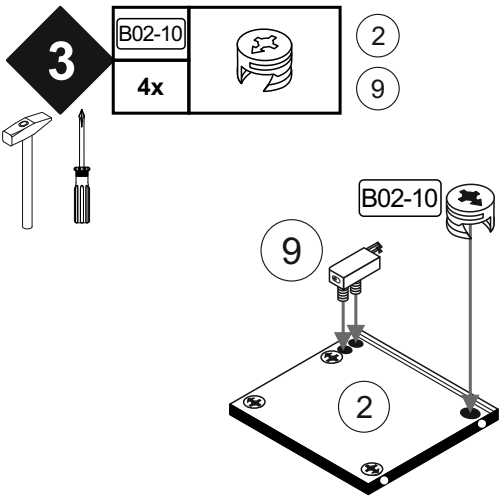
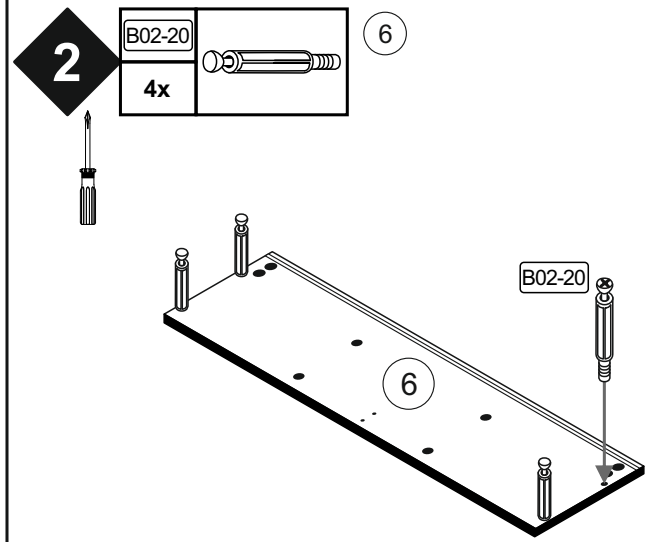
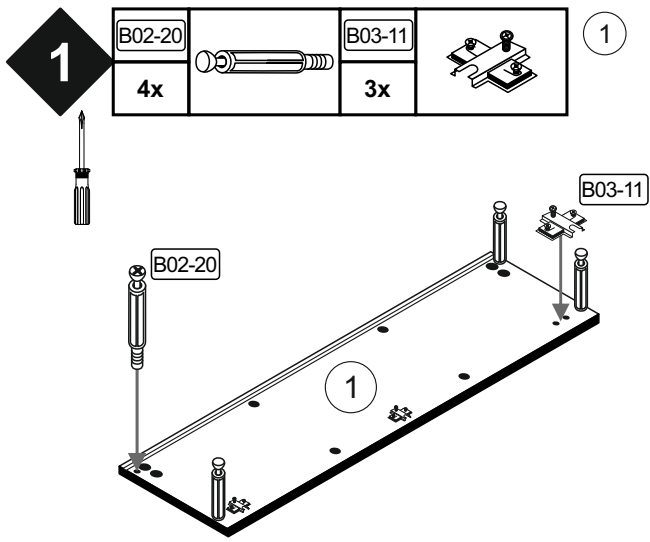

7

B05-130		2	3
1x		4	6

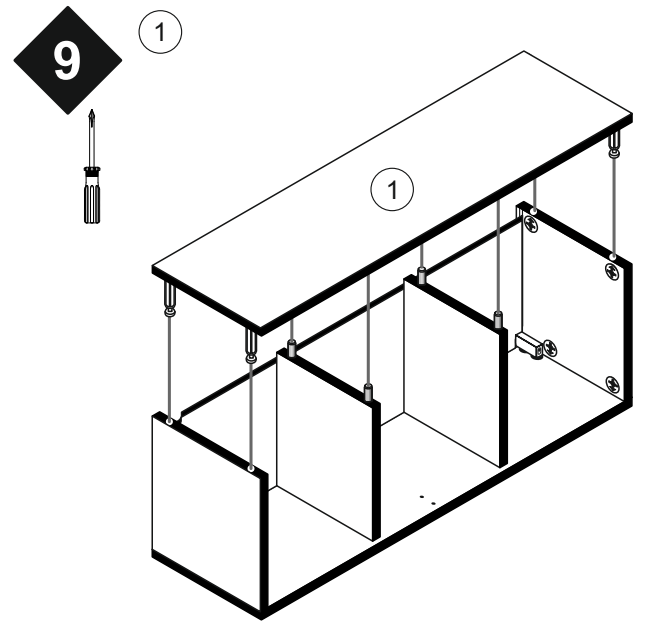
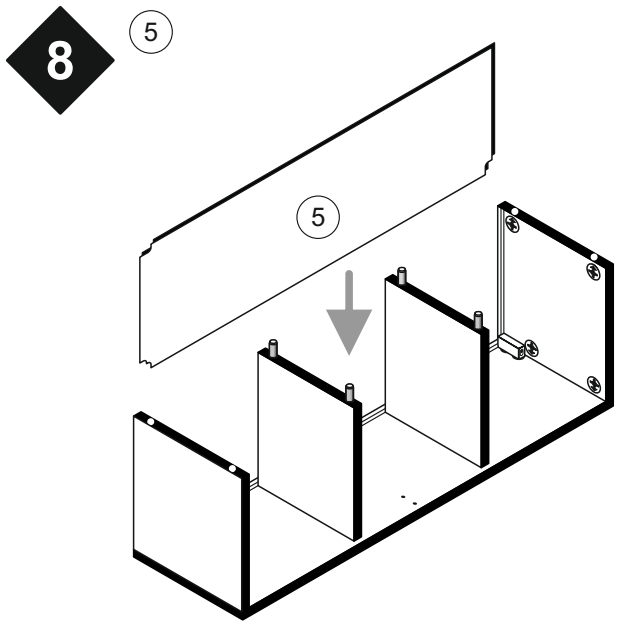
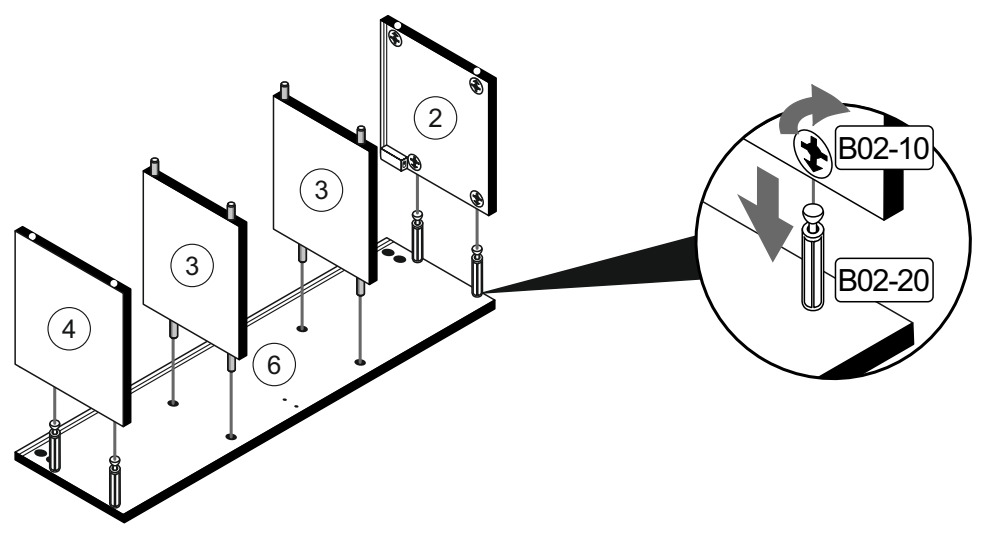

10

B01-30		B05-185		B01-90	
8x	3x16	4x		4x	3,5x20

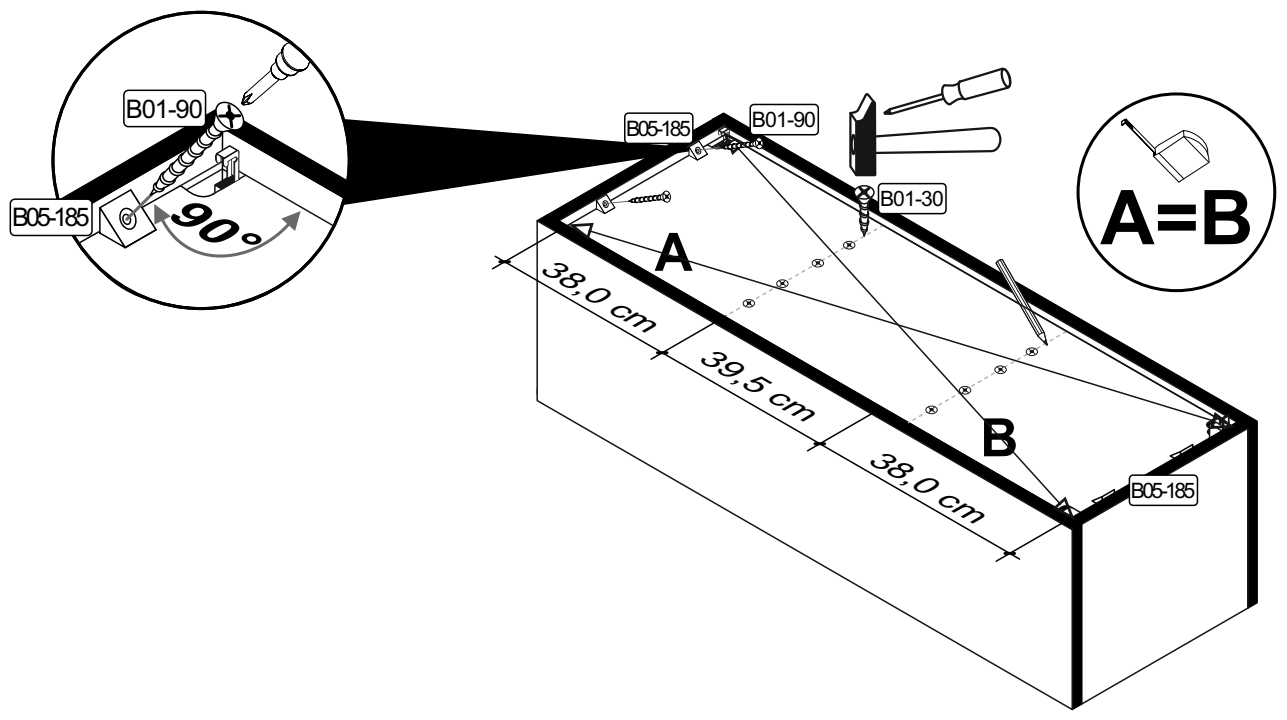

11 B01-80
2x 3,5x13 8

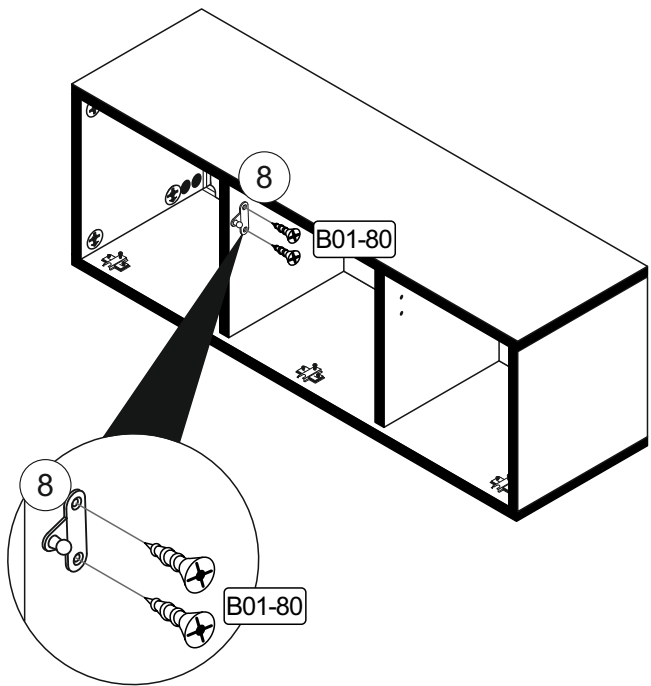
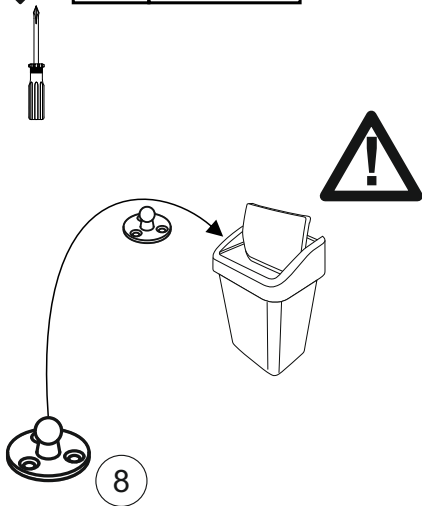

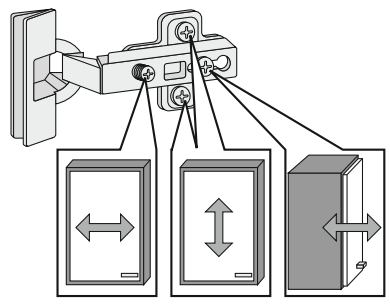
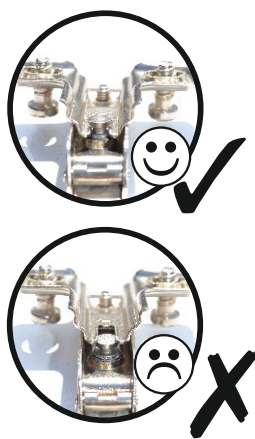
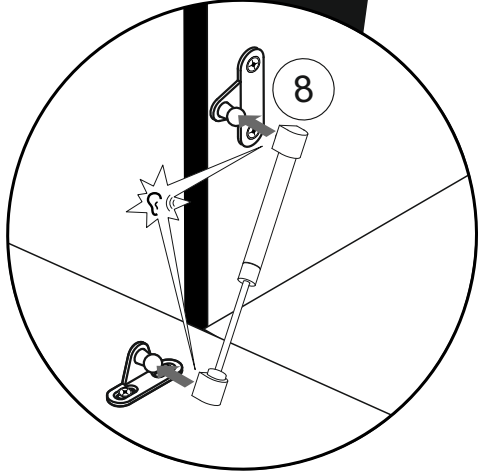
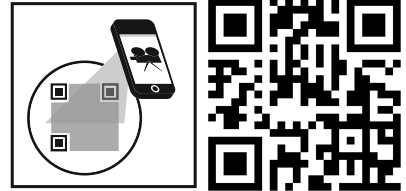
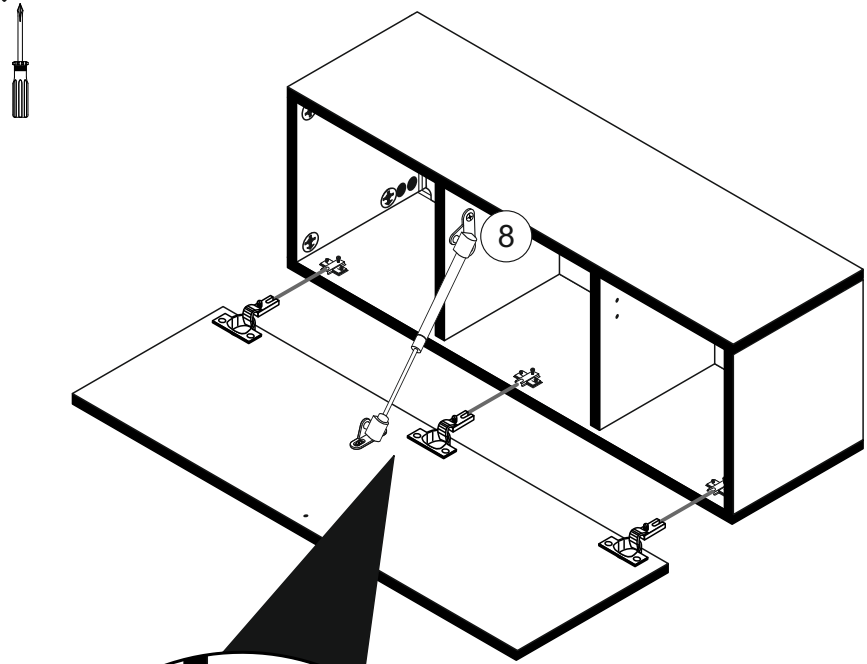

12 8

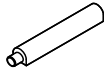

Türen einstellen (Scharniere justieren)
Adjusting the doors (adjusting the hinges)
Régler les portes (ajuster les charnières)
Sistemare le porte (regolare le cerniere)
Deuren instellen (scharnieren afstellen)
Nastawić drzwi (wyregulować zawiasy)
Vyrovnejte dvířka (seřid'ťe závěsy)
Nastavenie dverí (nastavenie závesov)
Állítsa be az ajtókat (állítsa be a zsanérokot)
Reglare ușii (ajustare balamale)
Kapıların ayarlanması (menteşelerin seviye ayarı)
Регулировка дверей (регулировка шарнира)

13

B01-80		B03-148		B03-149		B03-150	
3x	3,5x13	1x		1x		1x	



Bitte beachten:

- (3-149) mit (1-80) an der Oberplatte (6) befestigen
- (3-148) seitlich eindrücken
- (3-150) auf (3-148) heften
- (3-150) Schutzfolie entfernen
- Klappe schließen

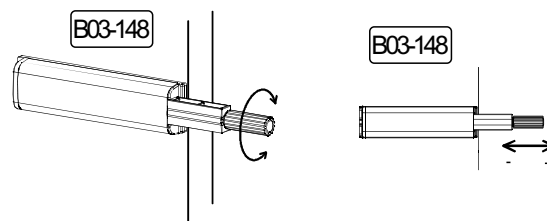
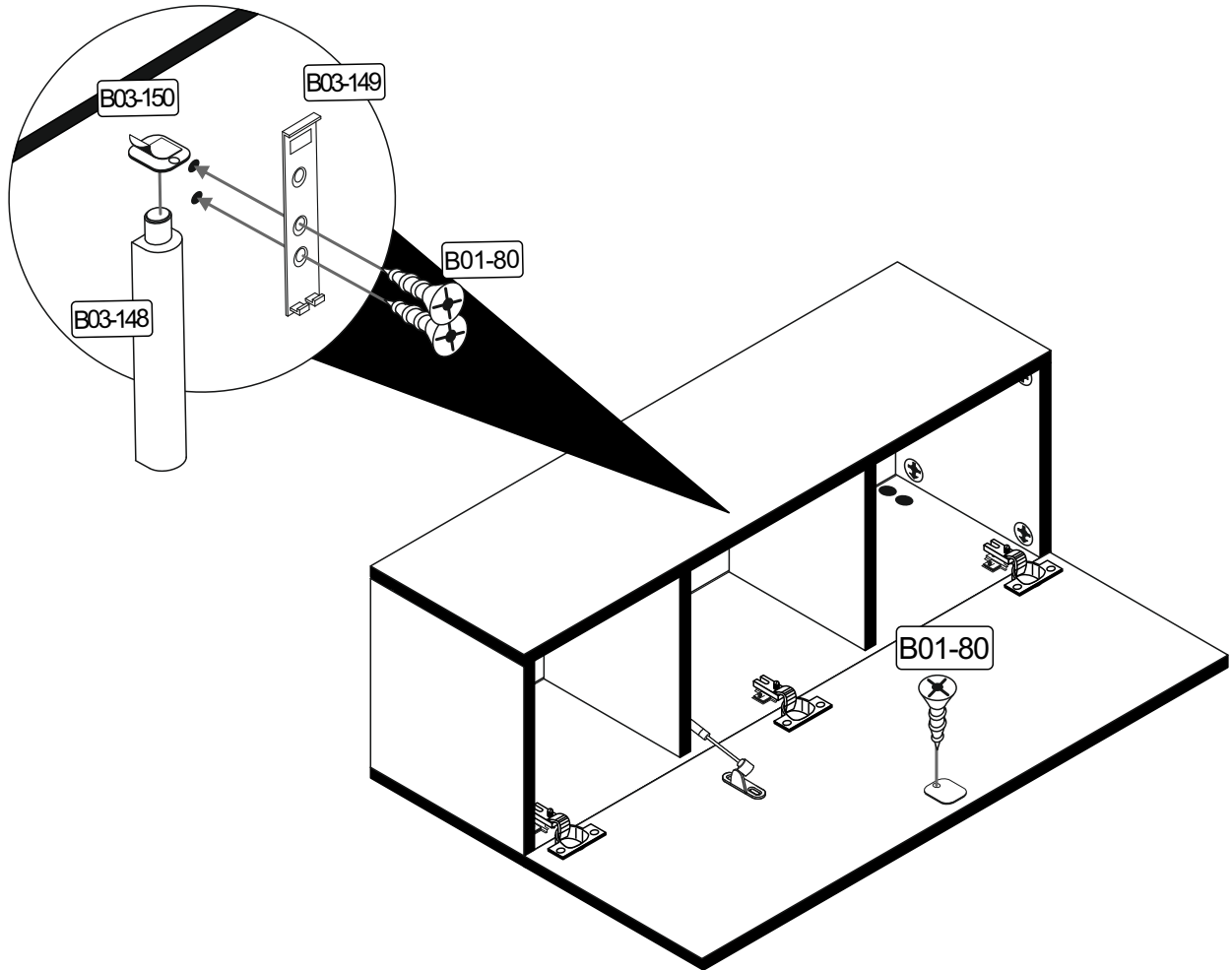
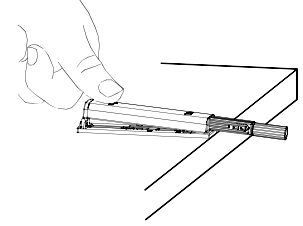

Zur Verstärkung oder Minderung des Hubes das vordere Stück des Beschlages hinein oder heraus drehen

14	B08-40	B08-70	B03-157	Push
	2x	2x	1x	

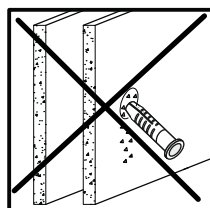
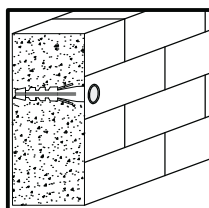
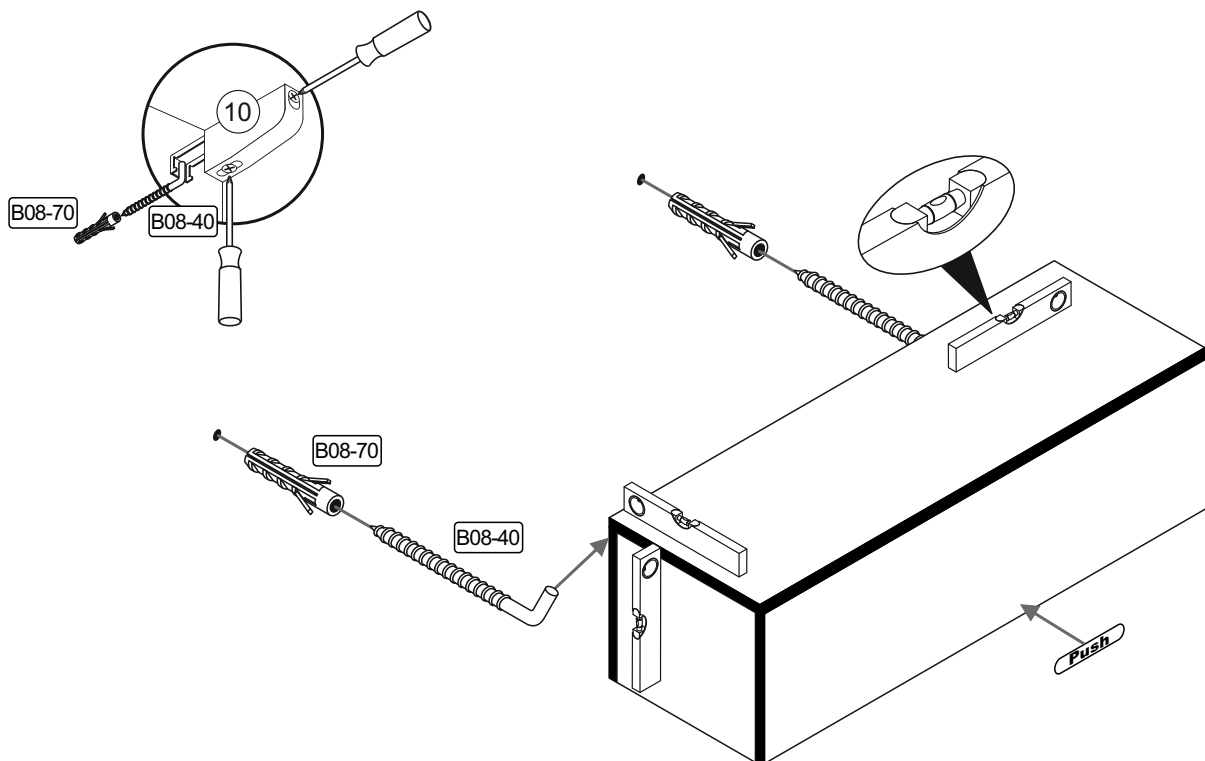
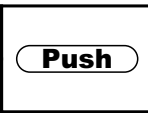
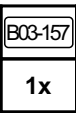
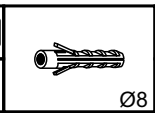
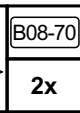
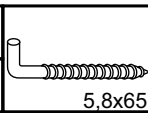

Achtung • Attention • Attenzione • Opgelet • Uwaga • Pozor • Figyelem • Atenție • Dikkat • Внимание	
(D)	Wandbefestigung dient als Kippschutz - unbedingt anbringen! Bei einigen Wandtypen kann ein Spezialdübel erforderlich sein!
(GB)	The wall fastening serves to prevent tipping - be absolutely sure to mount it! For certain wall types, a special wall plug may be necessary!
(FR)	La fixation murale sert de protection contre le basculement – à installer impérativement ! Pour certains types de murs il faut des chevilles spéciales !
(TR)	Duvardaki sabitleme, devrilmeye karşı bir emniyet tedbiridir ve mutlaka monte edilmelidir! Bazı duvar tiplerinde bunun için özel bir dübel gerekli olabilir!
(IT)	Il fissaggio alla parete serve da protezione anti-ribaltamento – attaccarla assolutamente! Per alcune strutture di parete può essere necessario un tassello speciale!
(NL)	Bevestiging aan de muur dient als kantelbescherming – zeker en vast bevestigen! Bij enkele muurtypes is een speciale plug misschien vereist!
(RU)	Обязательно установите крепление на стене во избежание опрокидывания! Для некоторых типов стен может потребоваться специальный дюбель!
(CZ)	Montáž na stěnu slouží jako ochrana proti převrnutí – bezpodmínečně umístěte! U některých typů stěn může být zapotřebí speciální hmoždinka!
(HU)	A terméket a falhoz kel rögzíteni, különben az felborulhat! Egyes faltípusoknál speciális tiplít kell használni!
(RO)	Sistemul de fixare la perete servește ca protecție la răsturnare - de montat obligatoriu! Pentru unele tipuri de pereți este posibil să fie necesar un diblu special!
(PL)	Mocowanie do ściany jest jednocześnie zabezpieczeniem przed przewróceniem – koniecznie zamontować! Do niektórych rodzajów ścian koniecznie zastosować specjalne kołki mocujące.
(SK)	Upevnenie na stenu slúži ako ochrana proti prevráteniu – bezpodmienečne použite! Pre niektoré druhy stien môže byť potrebná špeciálna hmoždinka!



(D) Videounterstützte Montageanleitung

(TR) Video destekli kurulum talimatları

(RU) инструкция по монтажу с помощью видеосигнала

(RO) Instrucțiuni de instalare acceptate video

(GB) Video-assisted assembly instructions

(IT) Istruzioni di montaggio video-assistite

(CZ) Instalační pokyny podporované videem

(PL) Instrukcje montażu wspomagane sygnałem wizyjnym

(FR) Instructions de montage assistées par vidéo

(NL) Video-ondersteunde montage-instructies

(HU) Video-támogatott telepítési utasítások

(SK) Inštaláčne pokyny podporované videom

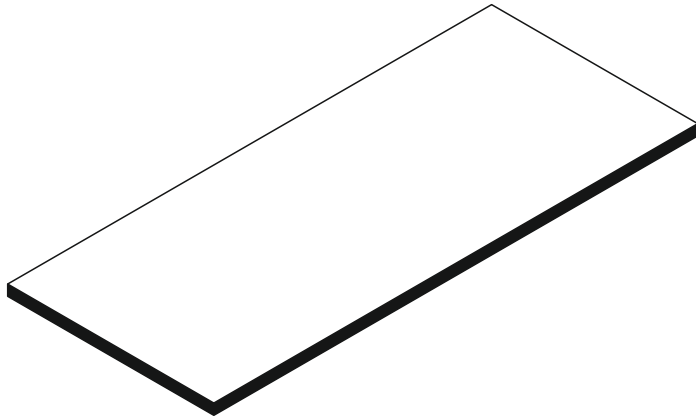
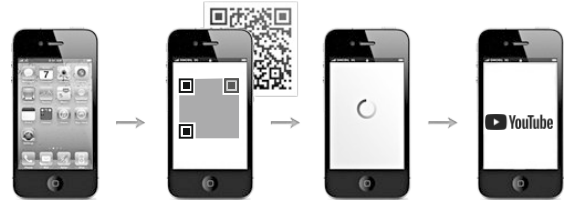

0205_160 Tischplatte

REPC-Nr.:

Service • Assistenza • Dienstverlening • Serwis
Servis • Szerviz • Сервисная служба

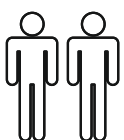
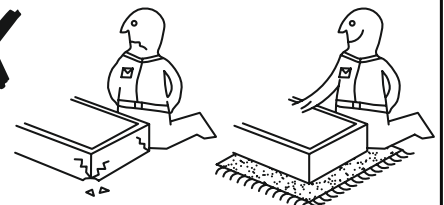
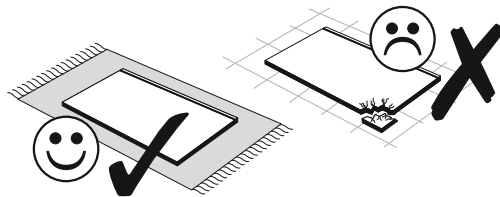
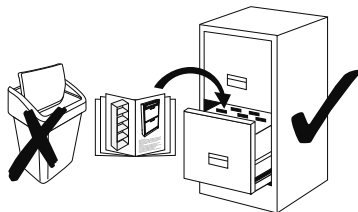
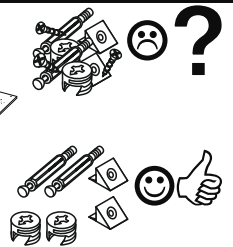
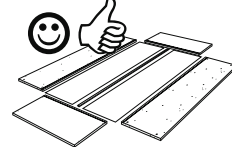
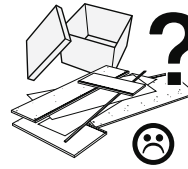
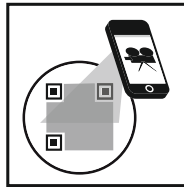
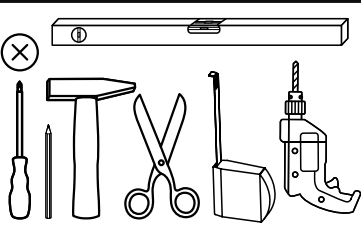

Das Ersatzteil-Anforderungsformular finden Sie auf <https://www.maeusbacher.de/ersatzteile/>

Colli 1/1

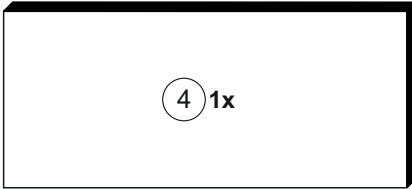

1600 x 700

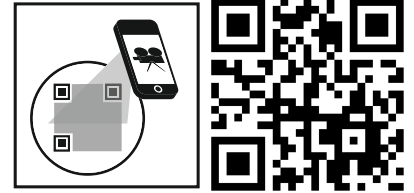



(D) Videounterstützte Montageanleitung

(TR) Video destekli kurulum talimatları

(RU) инструкция по монтажу с помощью видеосигнала

(RO) Instrucțiuni de instalare acceptate video

(GB) Video-assisted assembly instructions

(IT) Istruzioni di montaggio video-assistite

(CZ) Instalační pokyny podporované videem

(PL) Instrukcje montażu wspomagane sygnałem wizyjnym

(FR) Instructions de montage assistées par vidéo

(NL) Video-ondersteunde montage-instructies

(HU) Video-támogatott telepítési utasítások

(SK) Inštaláčn  pokyny podporované videom

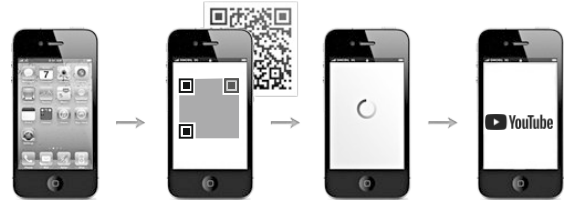
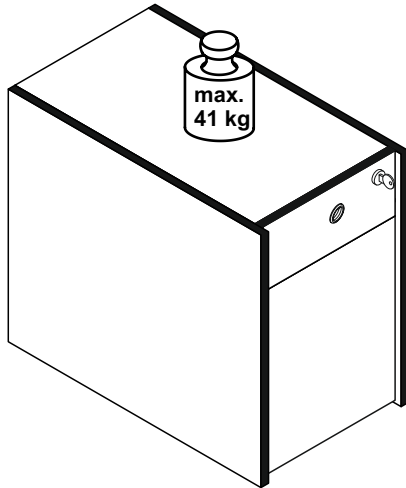

0213-US_11 Unterschrank

REPC-Nr.:

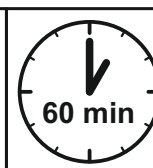
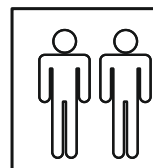
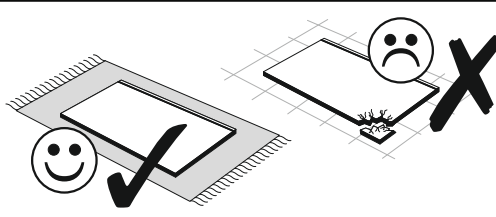
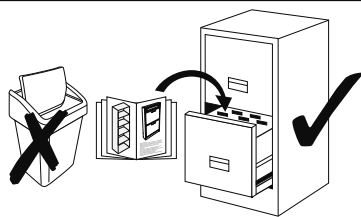
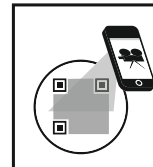
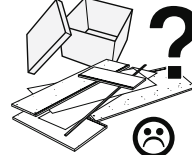
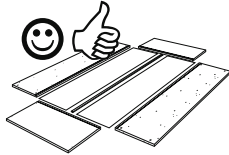
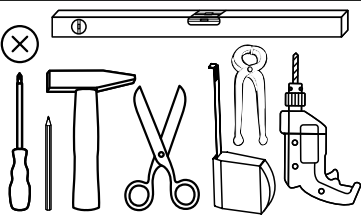

Service • Assistenza • Dienstverlening • Serwis
Servis • Szerviz • Сервисная служба

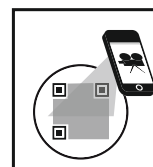

Das Ersatzteil-Anforderungsformular finden Sie auf
The replacement parts requisition form you find on
<https://www.maeusbacher.de/ersatzteile/>







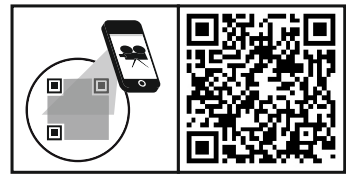





BT1-00005 Paket 1/1



B01-123		B02-173	
8x	4x15	4x	

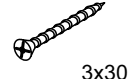



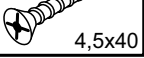

BT1-00271 Paket 1/1

B01-65		B01-80		B01-200		B02-103		B02-121		B01-30	
5x	3x13	7x	3,5x13	4x	6,3x13	8x	8x30	1x		4x	3x16
B02-10		B02-20		B02-160		B01-70		B02-08		B02-139	
16x	h=12mm	20x		8x		2x	3x30	4x	h=10mm	1x	

BT1-00272 Paket 1/1

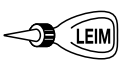
B03-11		B03-43		B03-07		B01-172	
2x		2x	15er	1x		4x	4,5x40

BT1-00273 Paket 1/1

B05-130		B03-148		B03-149		B03-150		B03-157	Push	B06-356	
1x		1x		1x		1x		1x		1x	sm

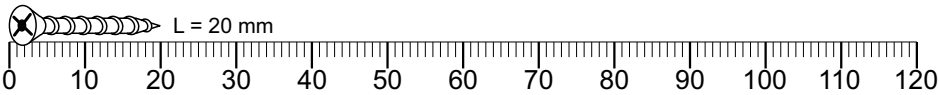

Paket 1/1

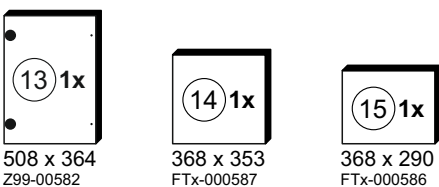
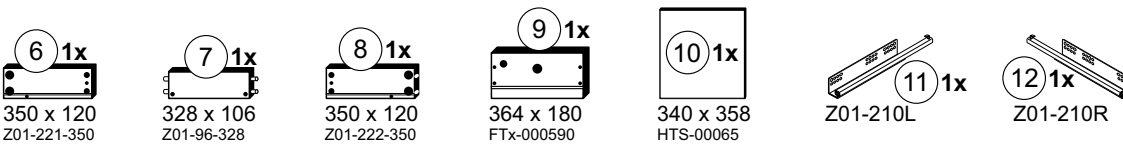
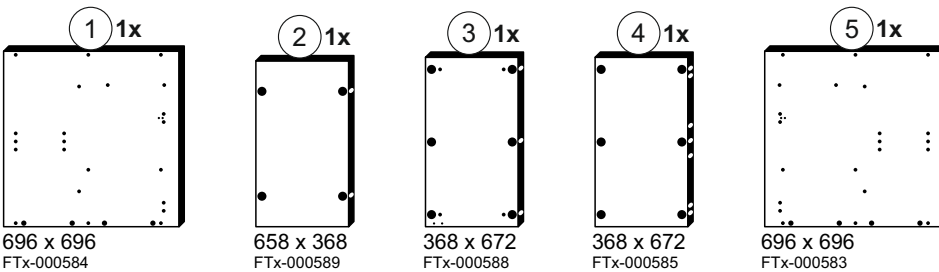

1	B02-20	B02-160	
	16x	8x	

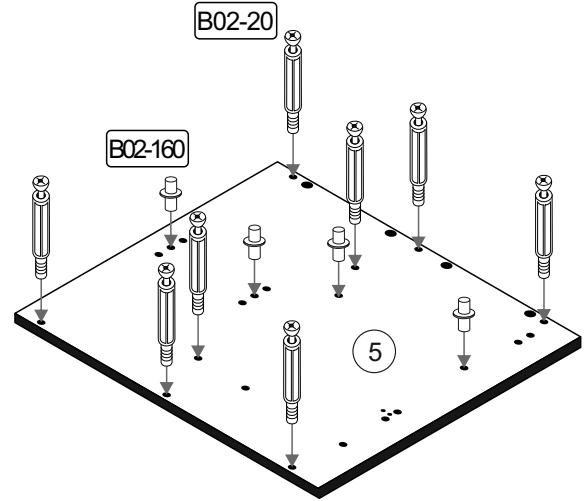
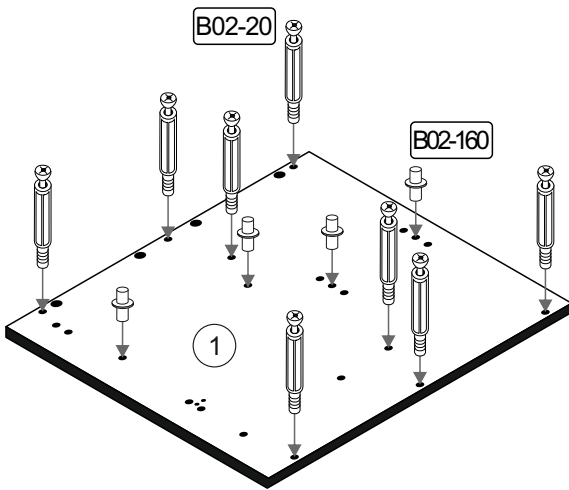

2	B02-10	B02-121	B01-65	3x13
	10x	1x	2x	

B02-10

h=12mm

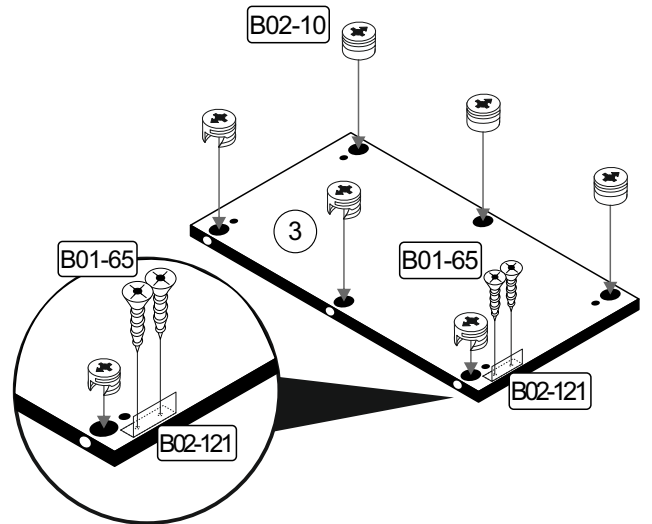
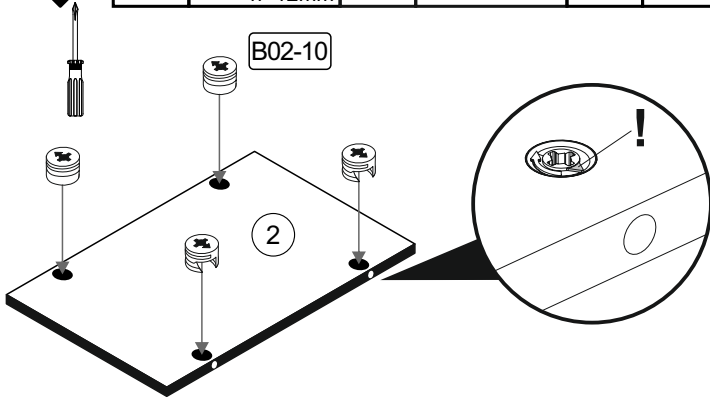

3	B02-10	B02-103	8x30
	6x	8x	
	B05-130	LEIM	
	1x		

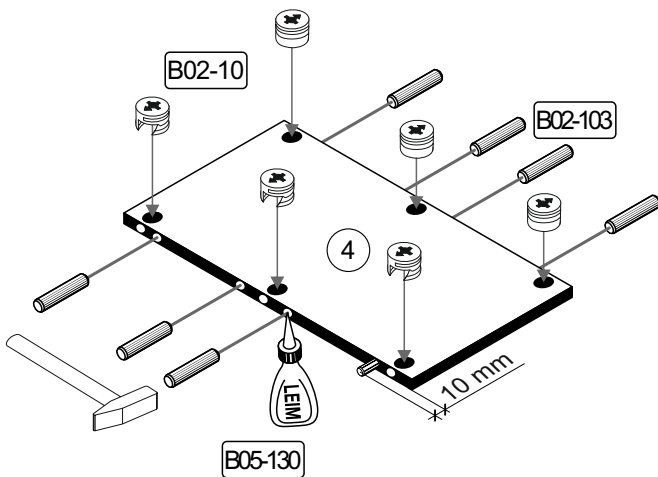
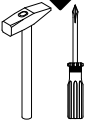

4	B03-43	B01-80	3,5x13
	2x	4x	

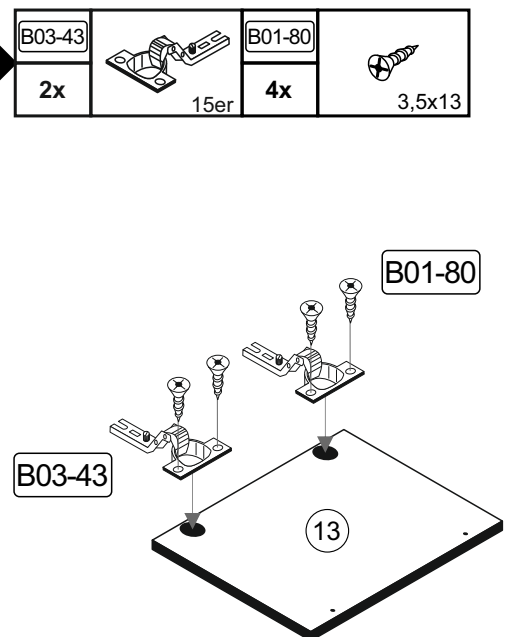

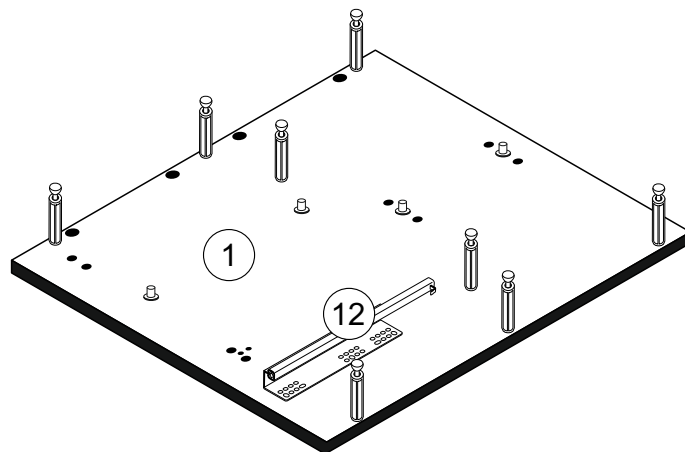
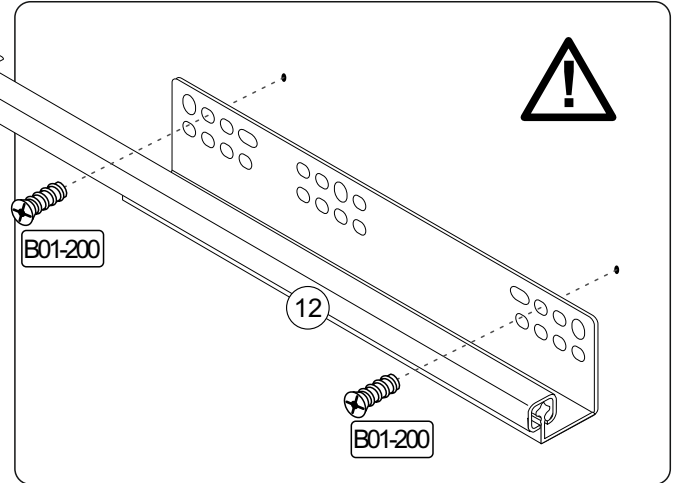
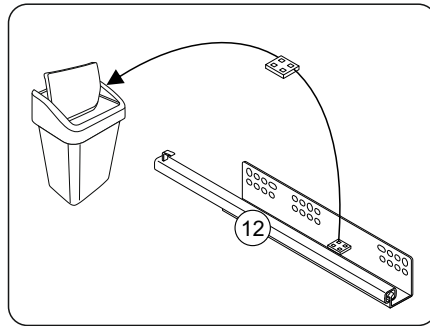
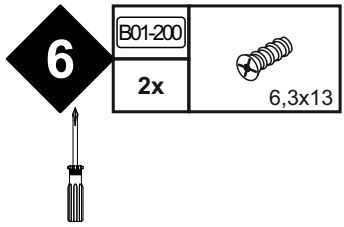
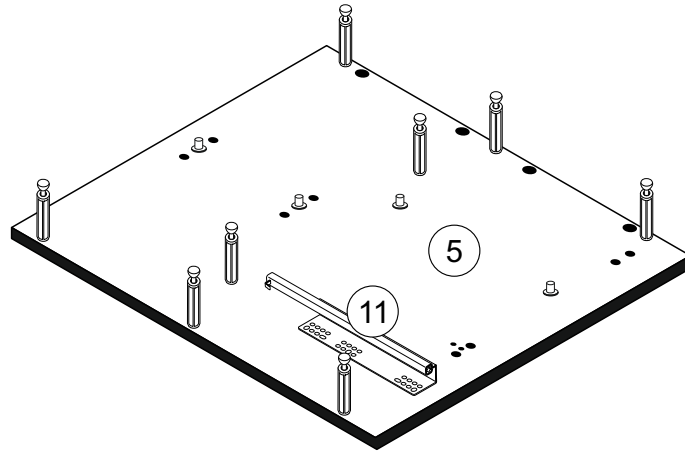
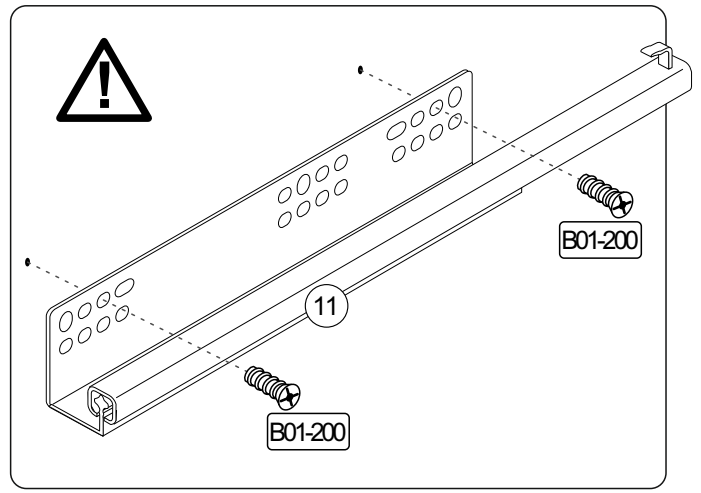
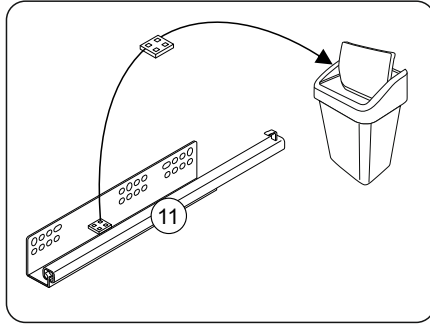
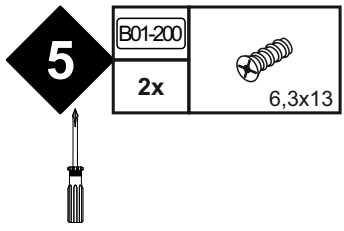

7	B02-08		B02-20		B02-139	
	4x	h=10mm	4x		1x	
	B01-65		B01-30		B06-356	sm
	3x	3x13	4x	3x16	1x	

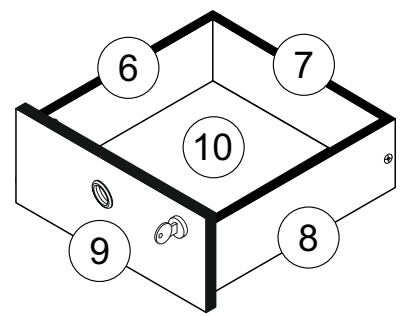

1

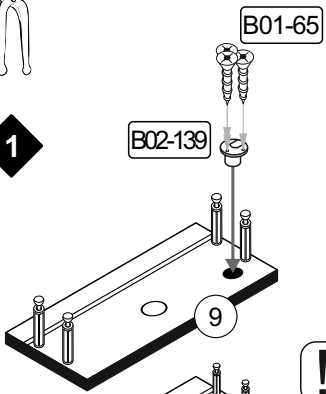

2

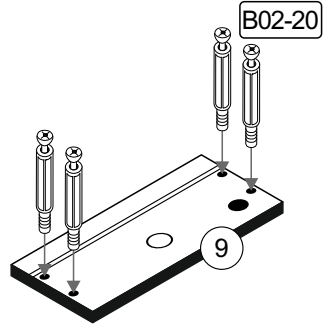

3

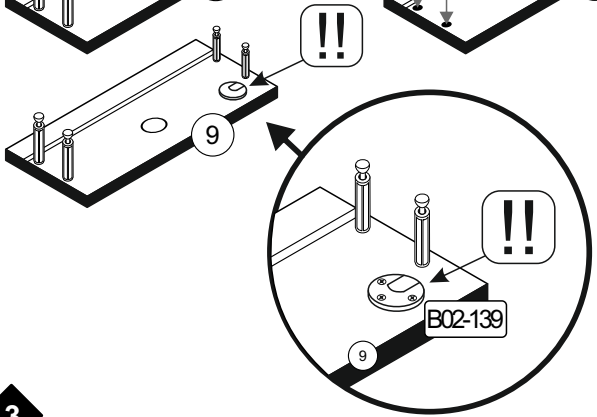

4

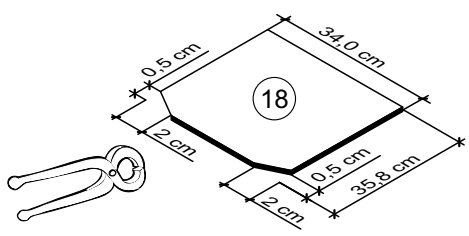
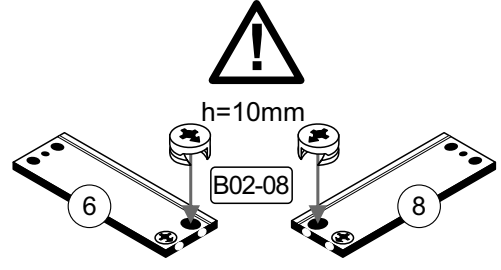

5

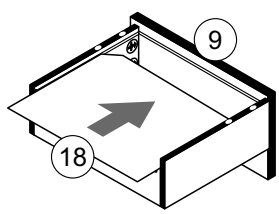

6

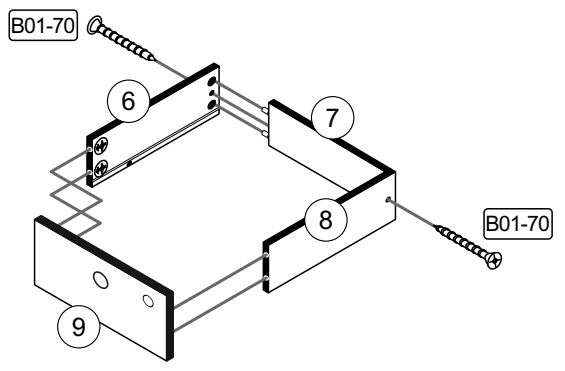

7

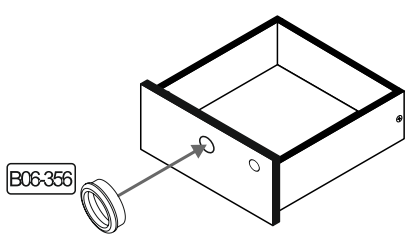

8

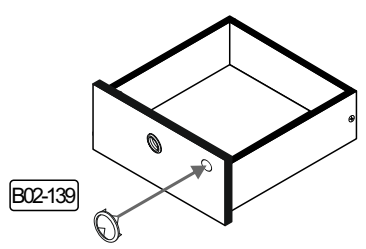
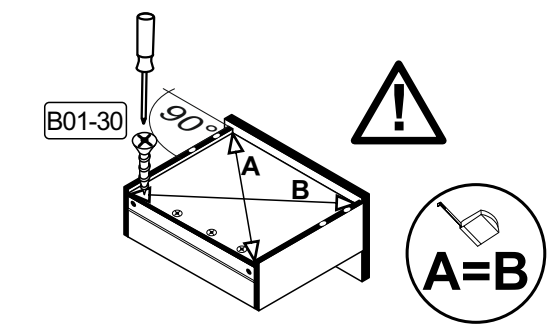

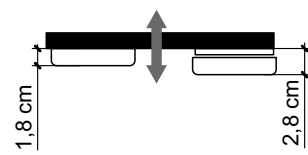
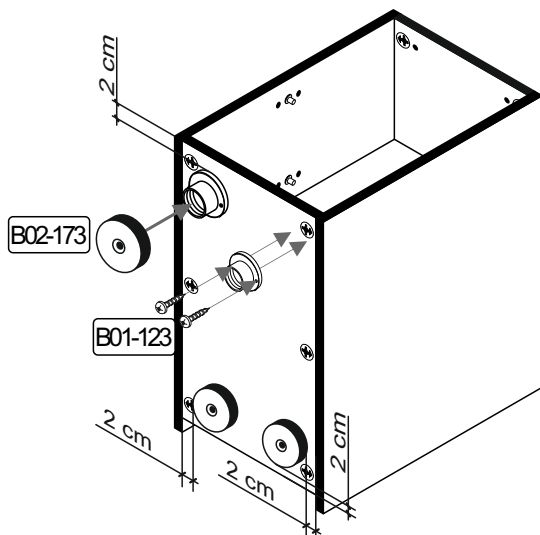
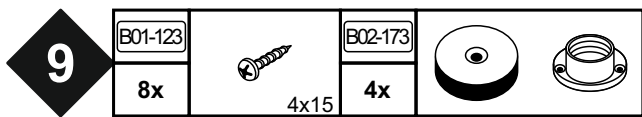
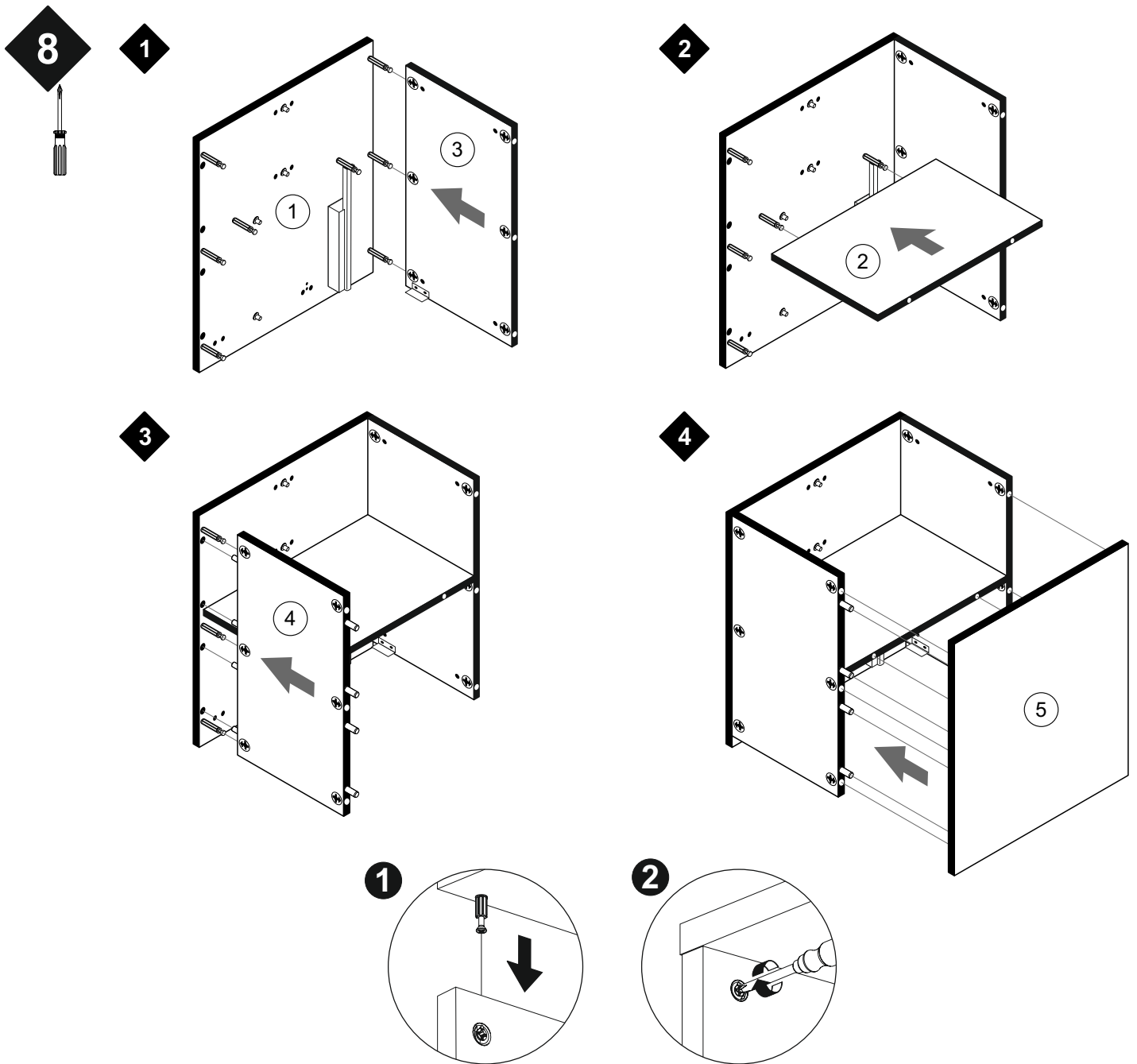

Höhenverstellung der Möbelfüße

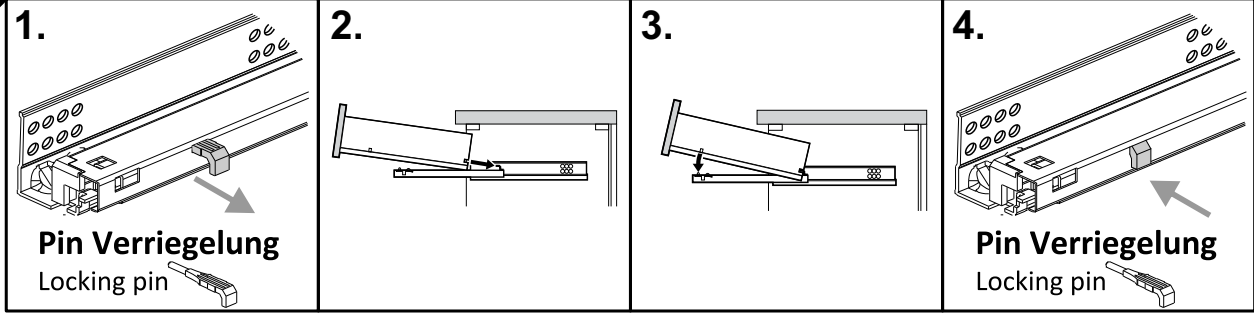
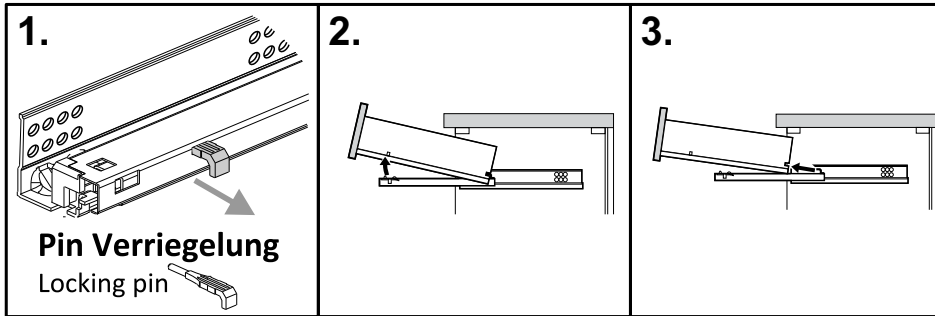
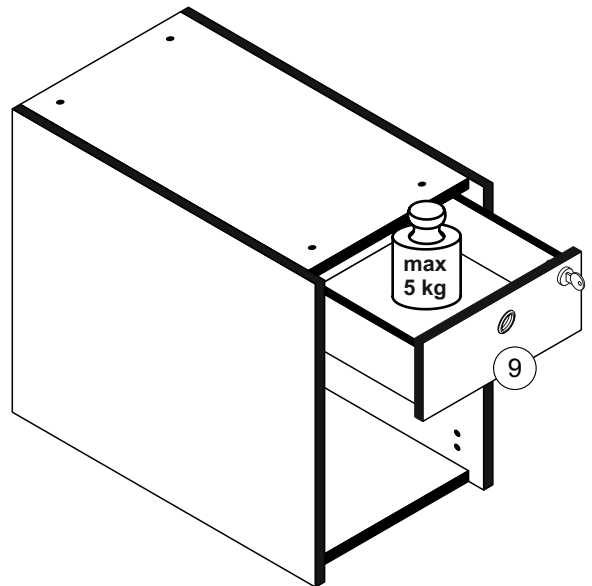
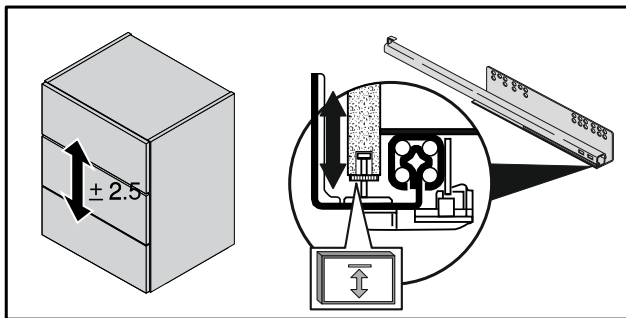
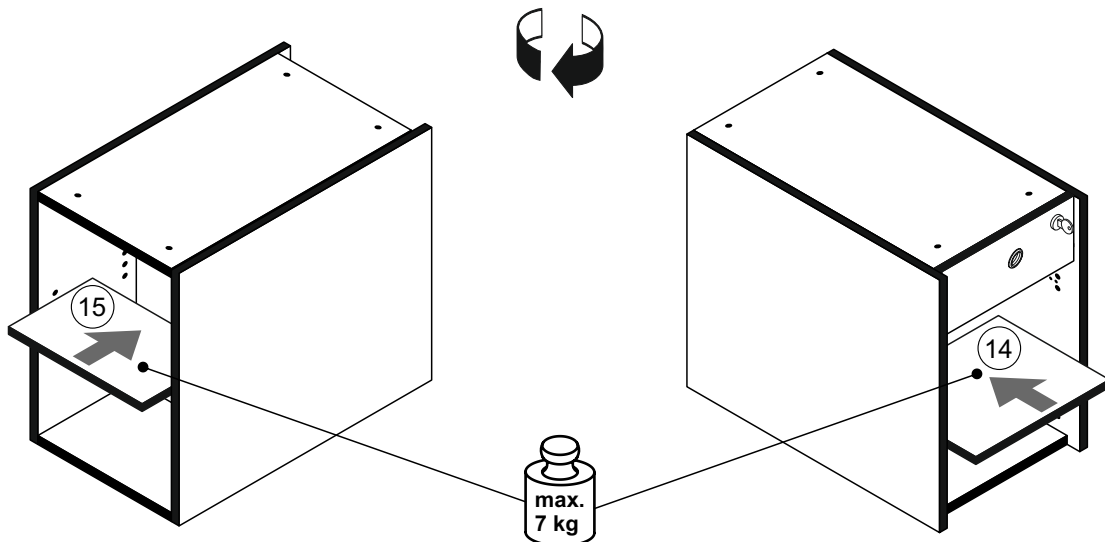
10**Einbau des Schubkastens****Ausbau des Schubkastens****Höhenverstellung des Schubkastens****11**

12	B03-11	B03-43	B03-07	B01-80	B03-150
	2x	2x	15er	1x	1x



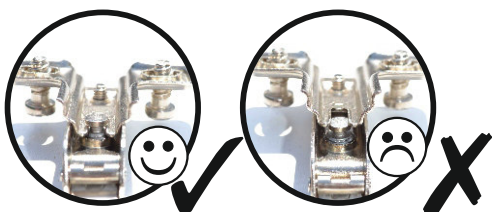
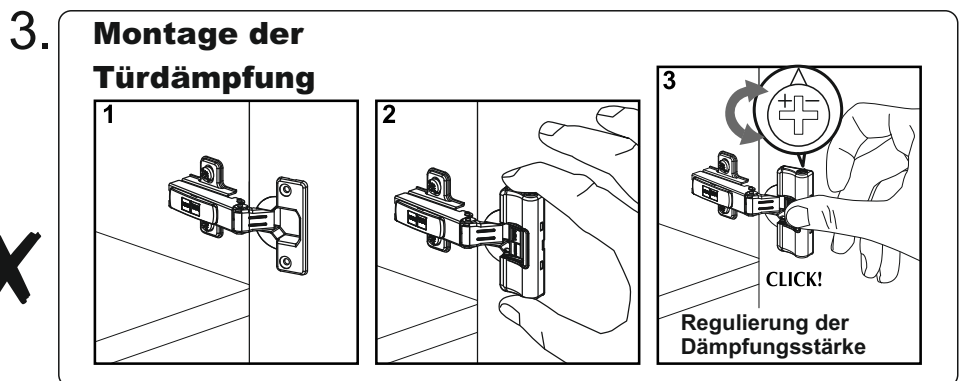
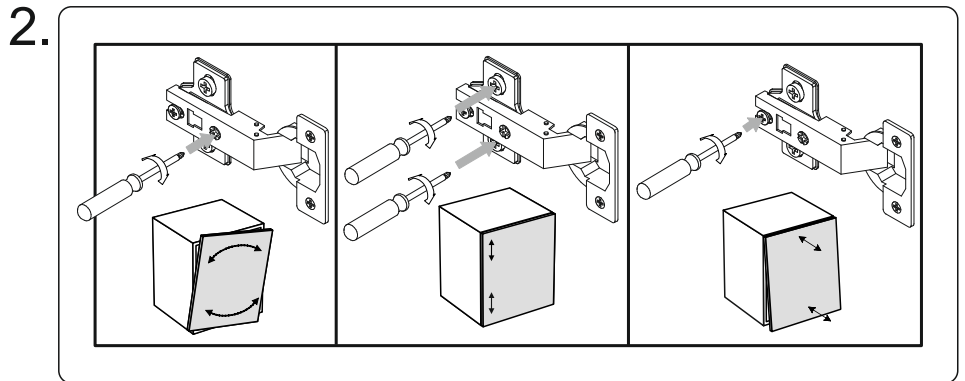
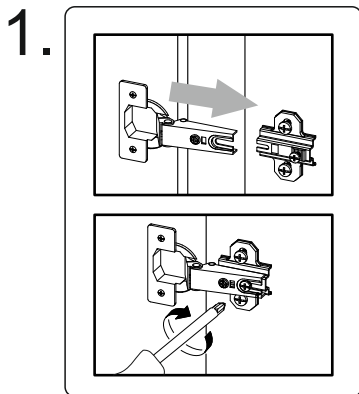
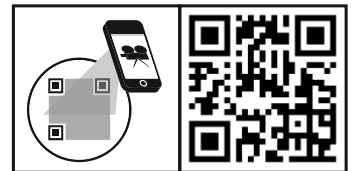
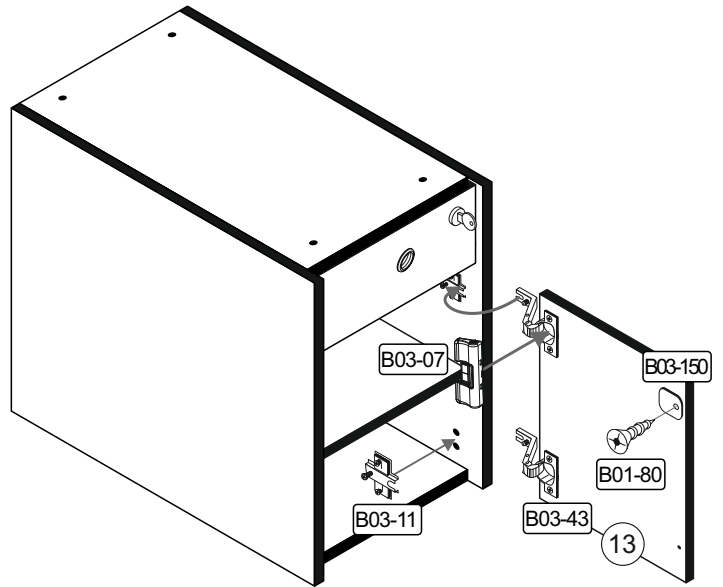
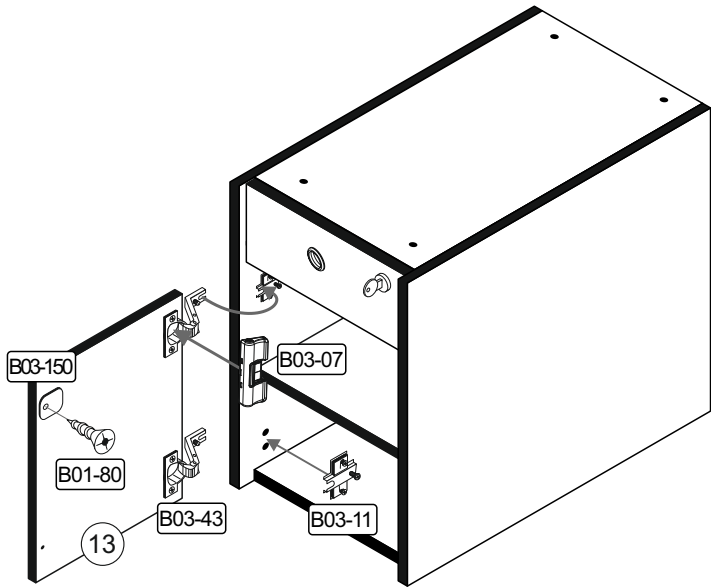

Tür links

Tür rechts

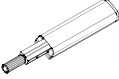

13

B01-80		B03-149		B03-148		B03-157	Push
2x	3,5x13	1x		1x		1x	



Tür links

Tür rechts

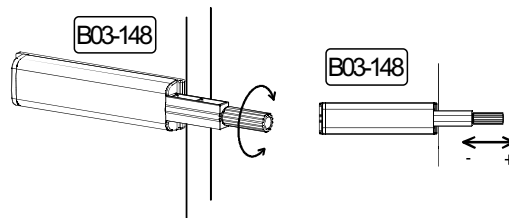
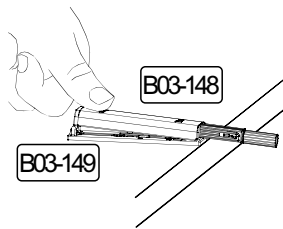
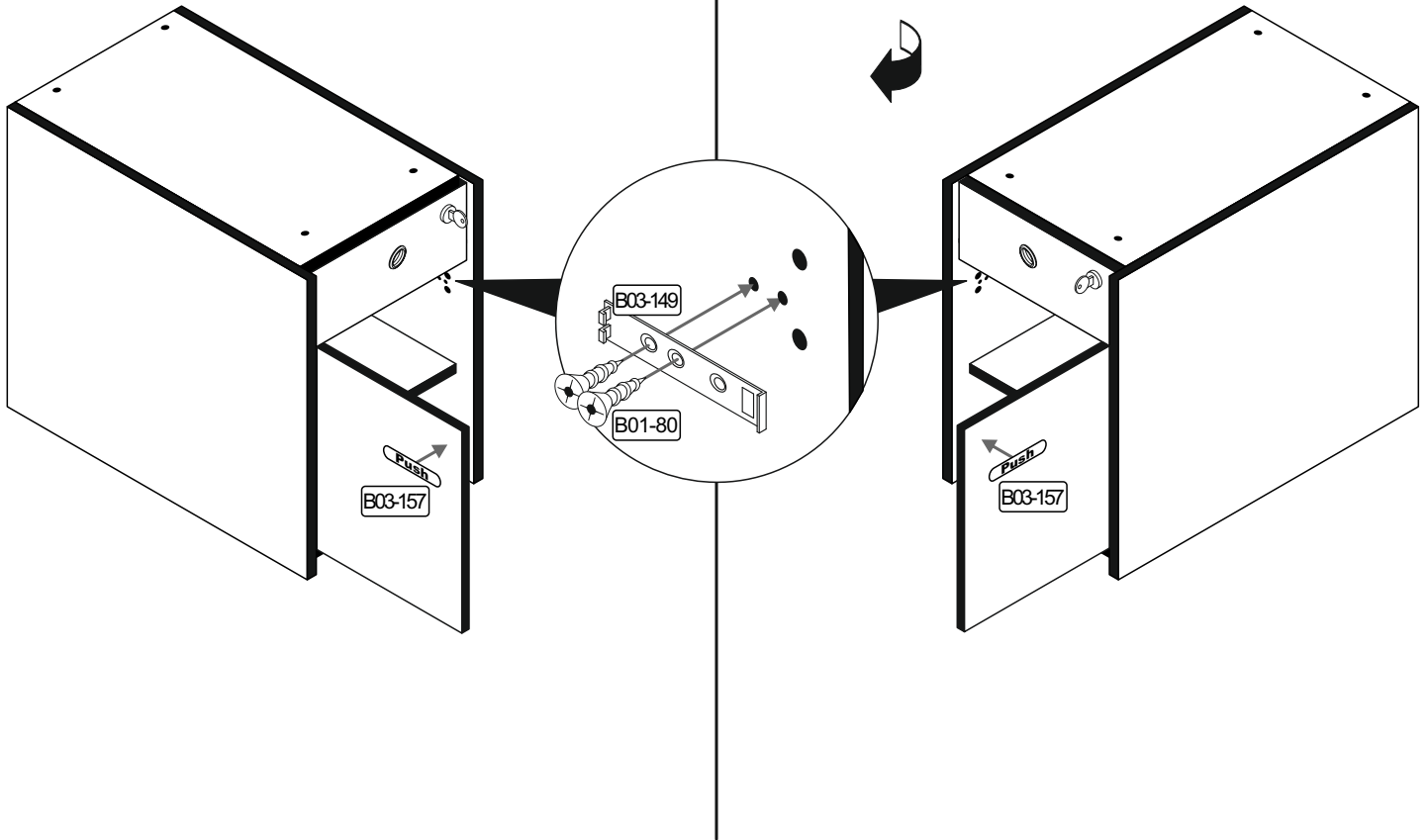

Zur Verstärkung oder Minderung des Hubes das vordere Stück des Beschlages hinein oder heraus drehen.

14

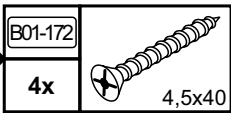

Tür links

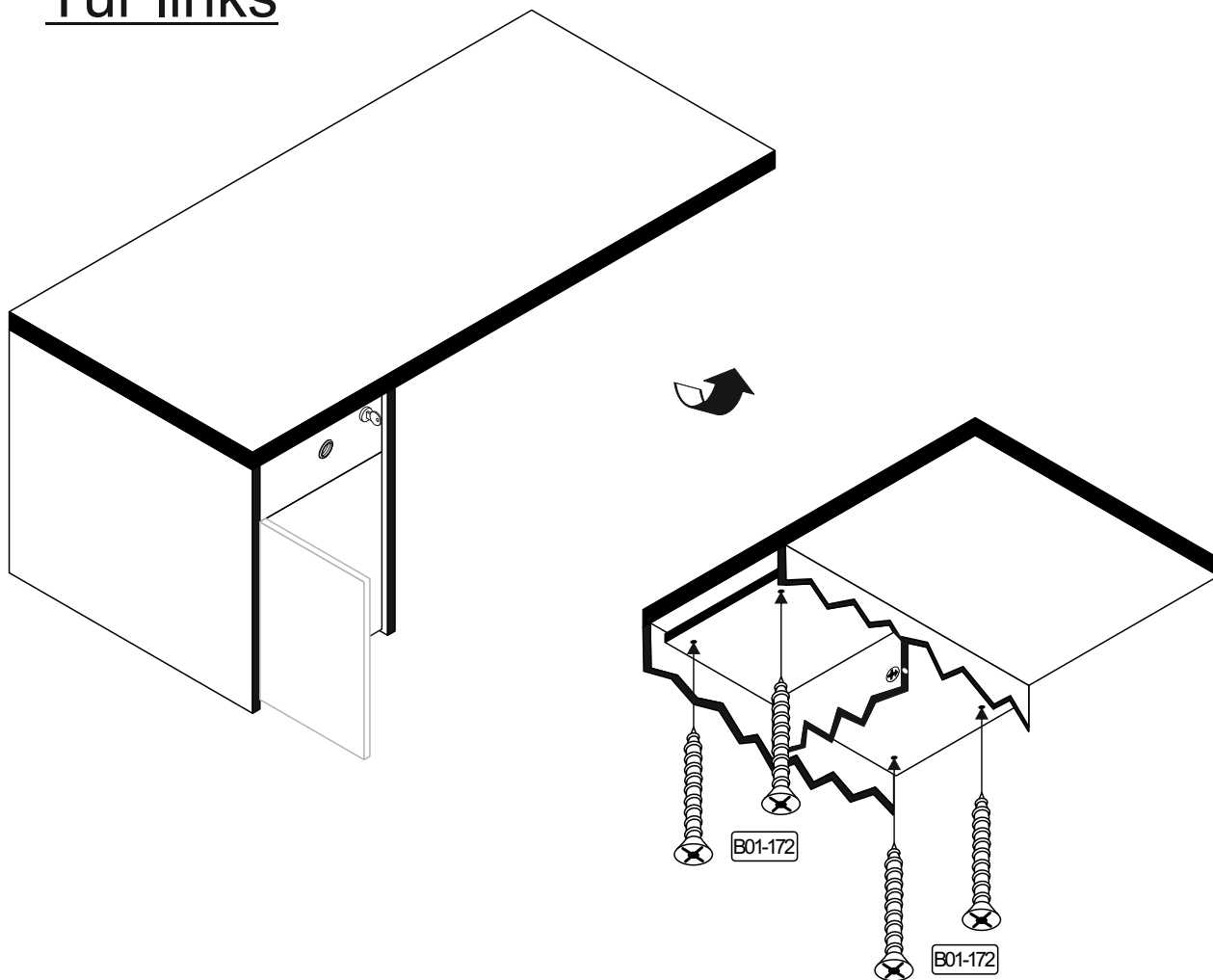

Tür rechts

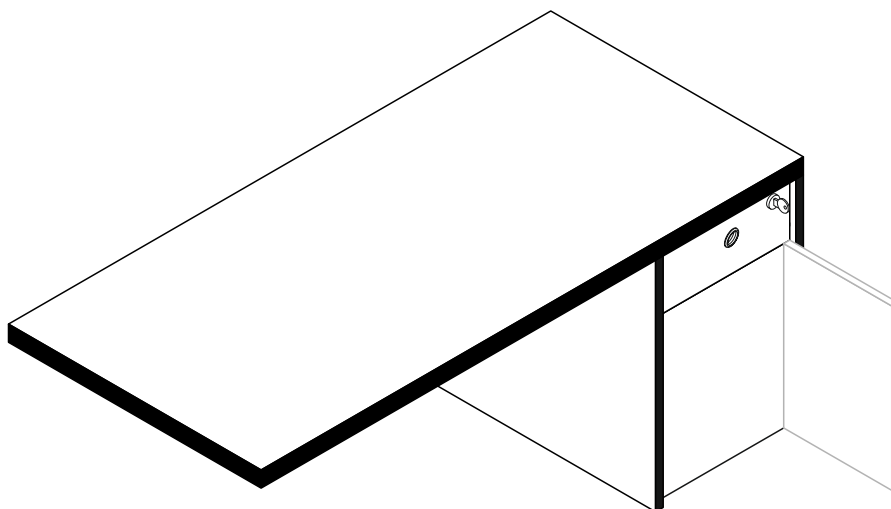



(D) Videounterstützte Montageanleitung

(TR) Video destekli kurulum talimatları

(RU) инструкция по монтажу с помощью видеосигнала

(RO) Instrucțiuni de instalare acceptate video

(GB) Video-assisted assembly instructions

(IT) Istruzioni di montaggio video-assistite

(CZ) Instalační pokyny podporované videem

(PL) Instrukcje montażu wspomagane sygnałem wizyjnym

(FR) Instructions de montage assistées par vidéo

(NL) Video-ondersteunde montage-instructies

(HU) Video-támogatott telepítési utasítások

(SK) Inštačné pokyny podporované videom

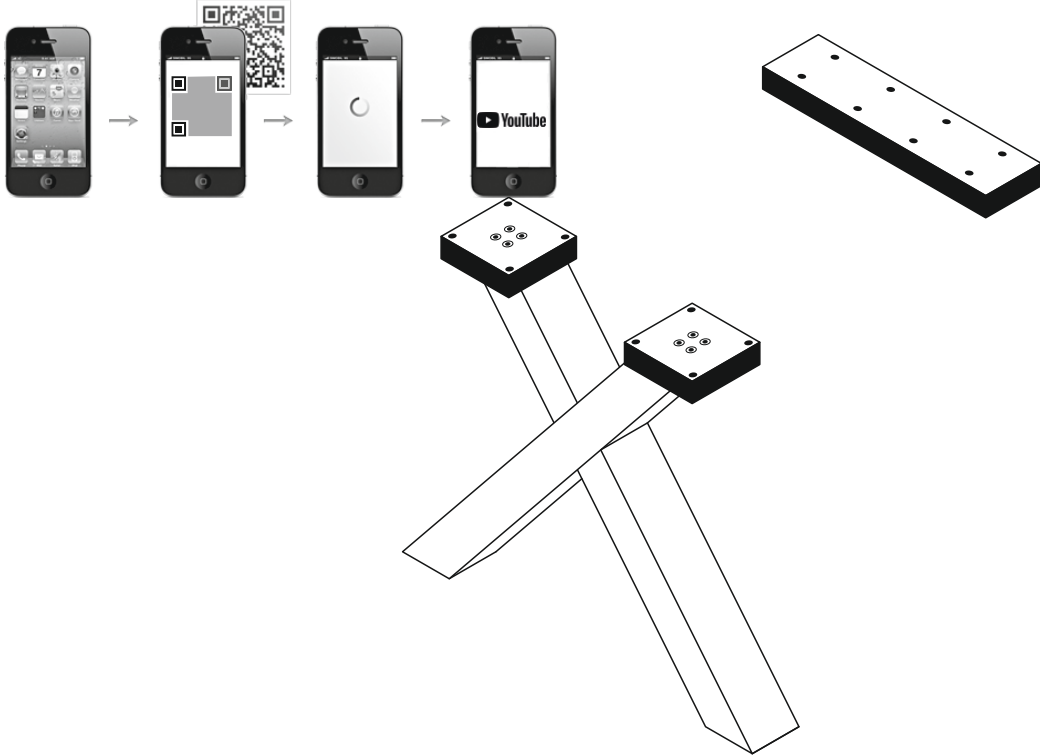

Art.Nr. : 0205_X-1er (zerl.) Untergestell/X

REPC-Nr.:

**Service • Assistenza • Dienstverlening • Serwis
Servis • Szerviz • Сервисная служба**

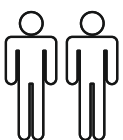
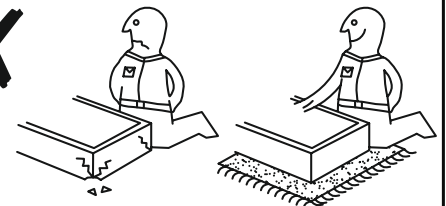
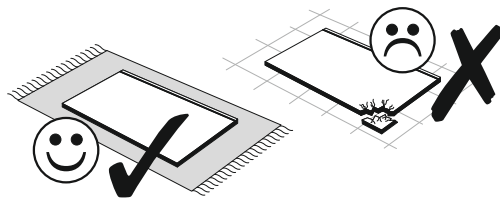
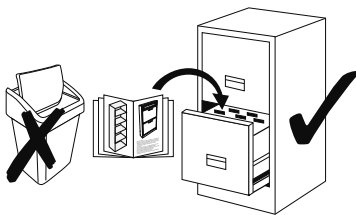
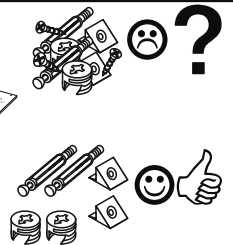
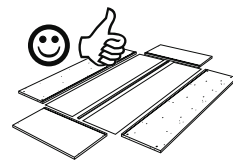
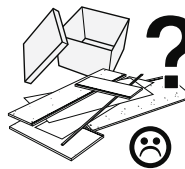
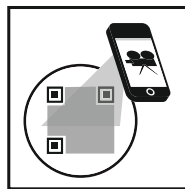
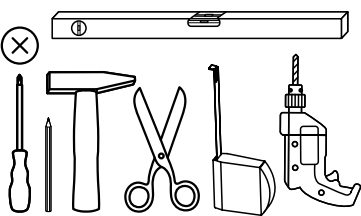

Colli 1/1: ① ② ③ Beutel 1/2, 2/2

Das Ersatzteil-Anforderungsformular finden Sie auf <https://www.maeusbacher.de/ersatzteile/>

Beutel 1/2

1-33		1-38		1-172		1-180		2-104		2-220	
8x	4x17	8x	4,5x35	12x	4,5x40	8x	6x45	3x	8x40	2x	

5-130	
1x	

Beutel 2/2

2-166	
16x	

Colli 1/1

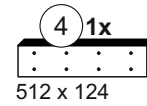
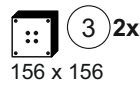
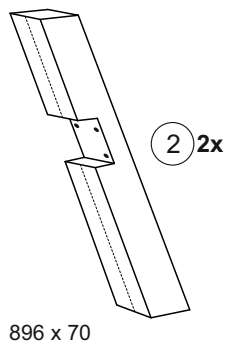
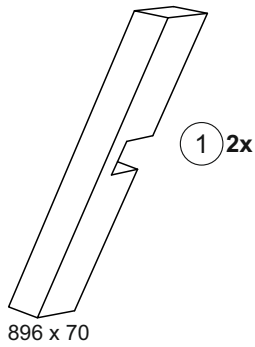
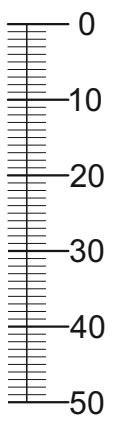
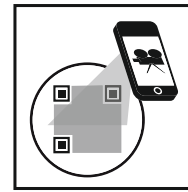

1	2-166		1
	8x		2

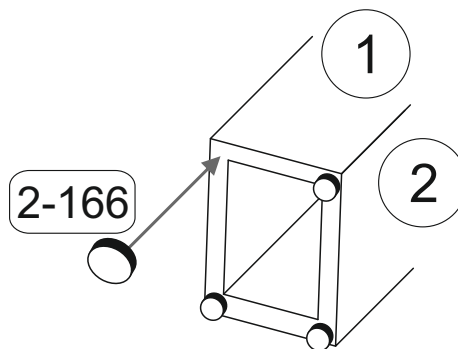

2	2-104		5-130		2
	3x		8x40		

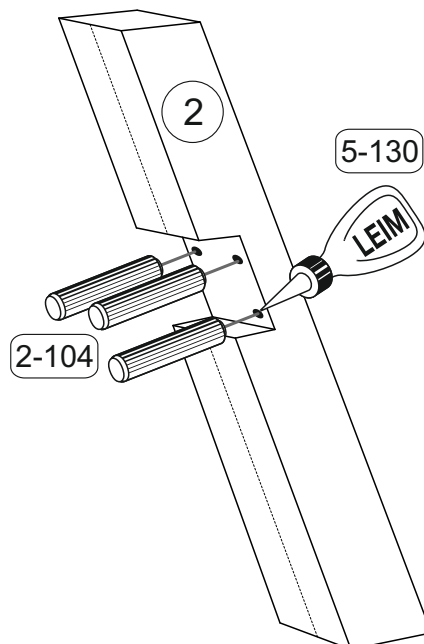

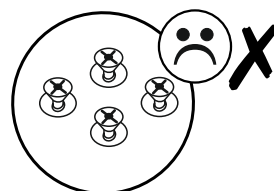
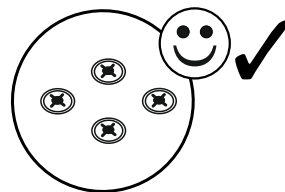
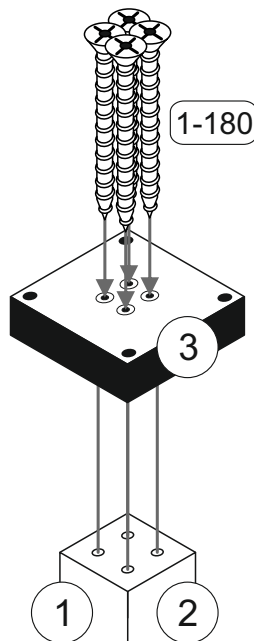
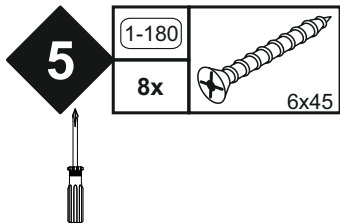
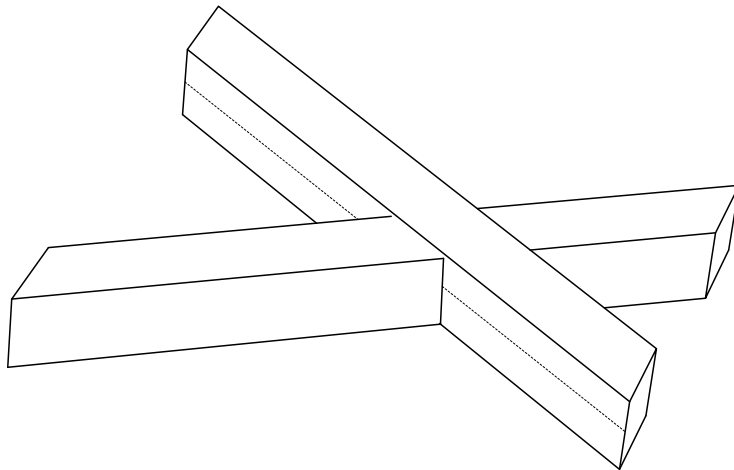
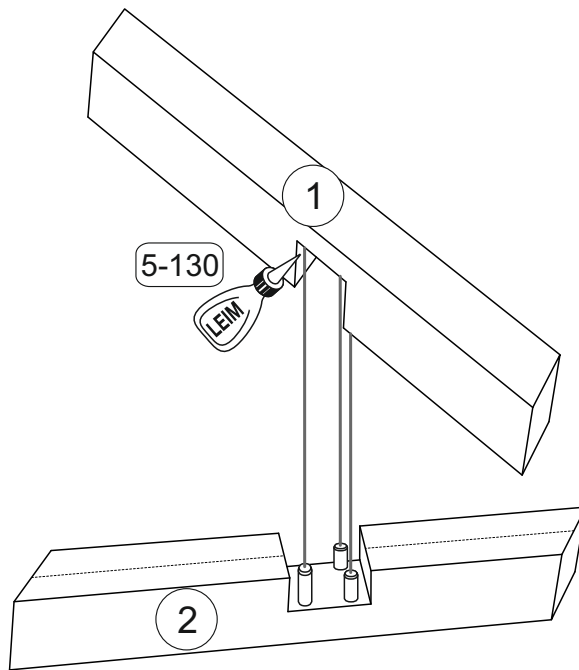
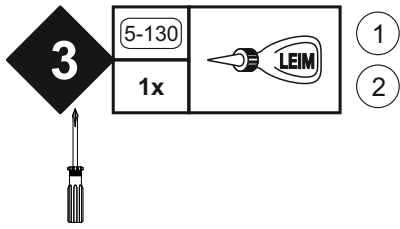

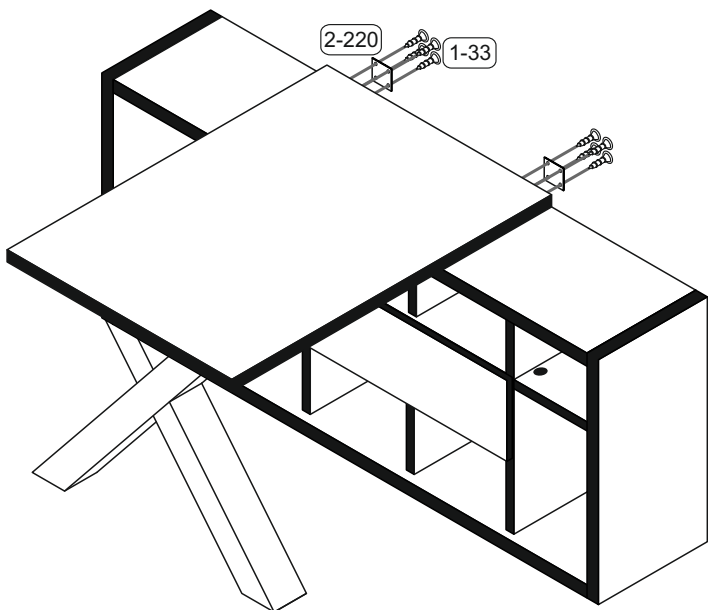
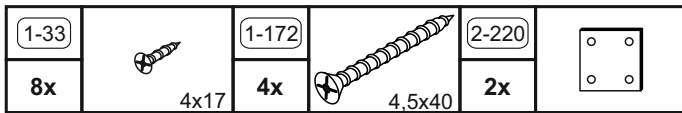
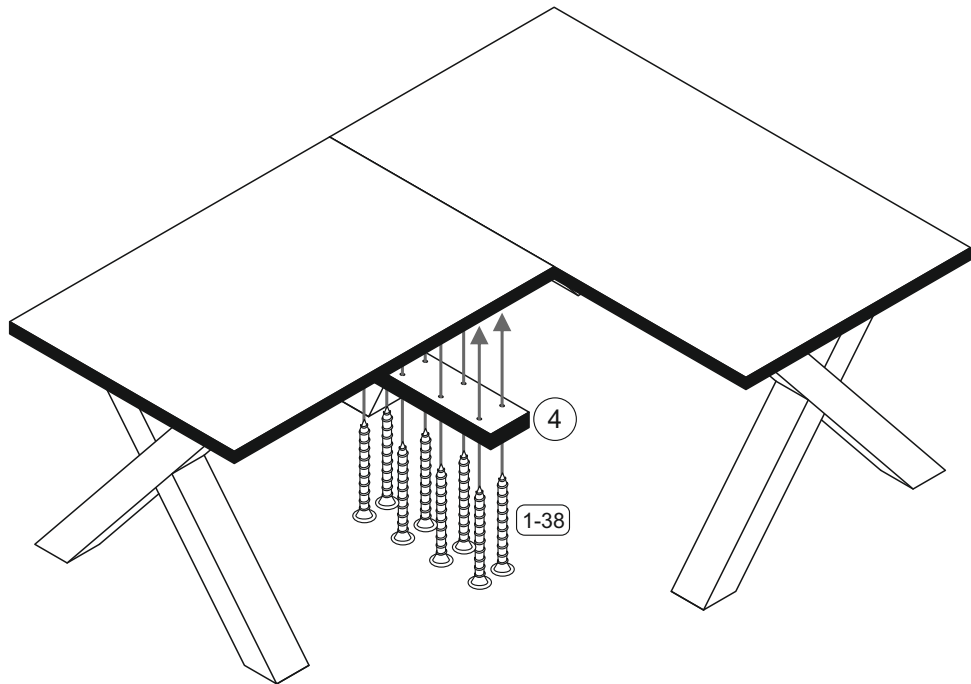
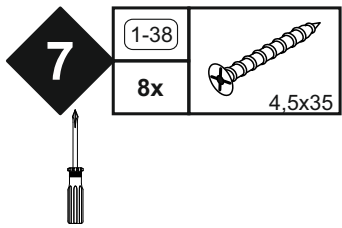
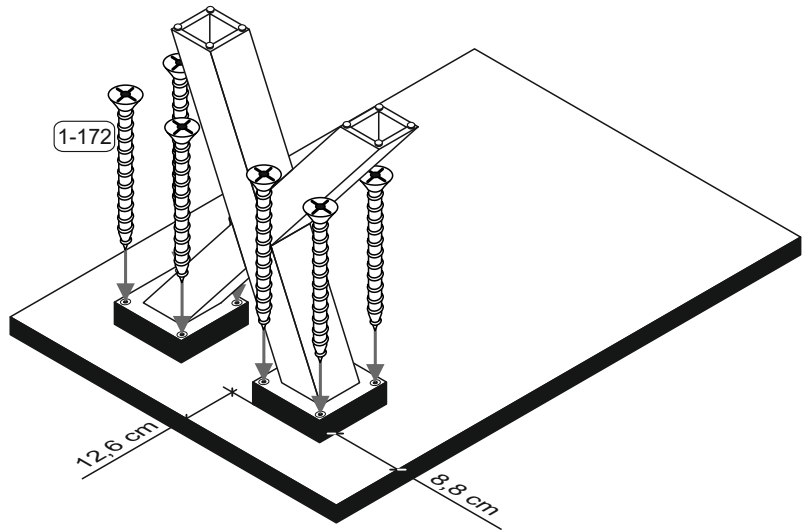
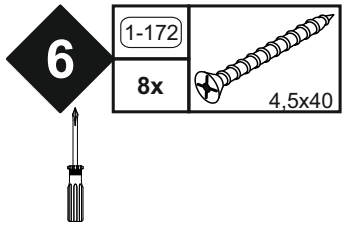

Montage an der Wand stehend

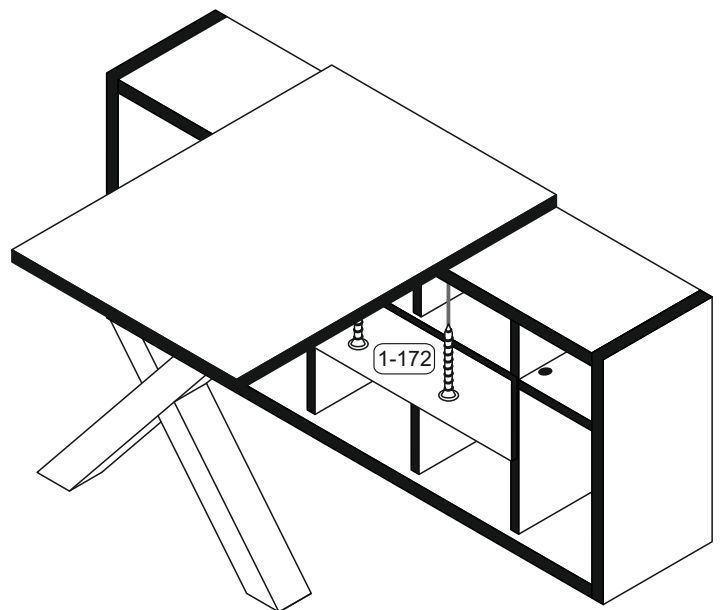

Montage frei im Raum stehend



(D) Videounterstützte Montageanleitung

(TR) Video destekli kurulum talimatları

(RU) инструкция по монтажу с помощью видеосигнала

(RO) Instrucțiuni de instalare acceptate video

(GB) Video-assisted assembly instructions

(IT) Istruzioni di montaggio video-assistite

(CZ) Instalační pokyny podporované videem

(PL) Instrukcje montażu wspomagane sygnałem wizyjnym

(FR) Instructions de montage assistées par vidéo

(NL) Video-ondersteunde montage-instructies

(HU) Video-támogatott telepítési utasítások

(SK) Inštaláčn  pokyny podporované videom

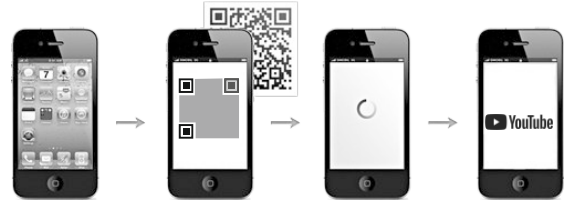
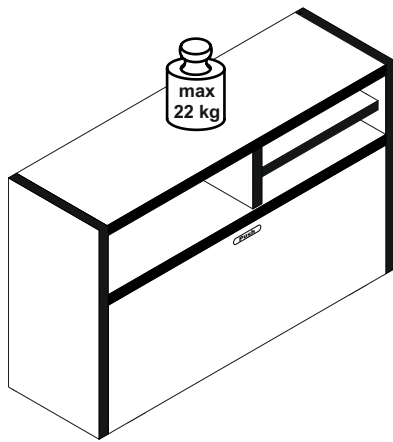

0221-HS_001 Hangeschi rank

REPC-Nr.:

Service • Assistenza • Dienstverlening • Serwis
Servis • Szerviz • Сервисная служба

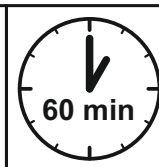
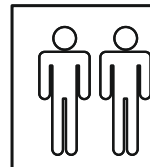
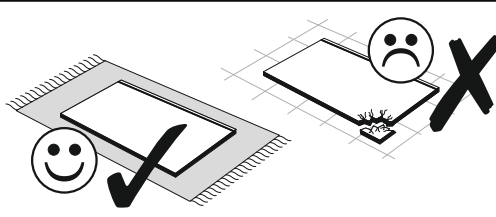
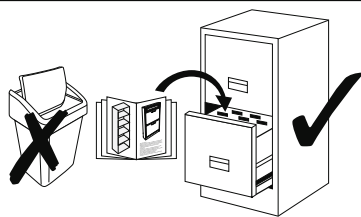
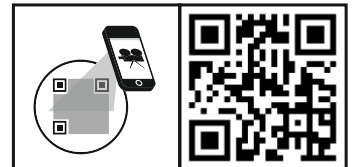
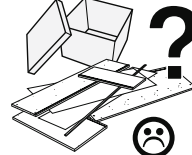
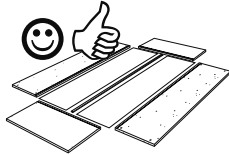
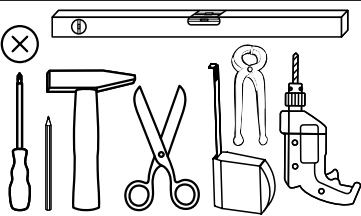

Das Ersatzteil-Anforderungsformular finden Sie auf
The replacement parts requisition form you find on
<https://www.maeusbacher.de/ersatzteile/>

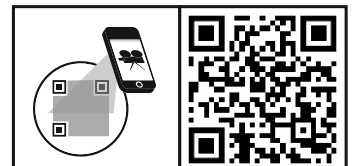

BT1-00281 1/1

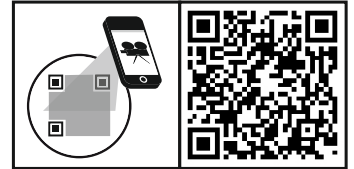
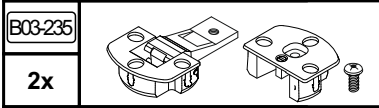

BT1-00280 1/1

B01-30		B01-65		B01-200		B01-90		
16x	3x16	13x	3x13	2x	6,3x13	4x	3,5x20	
B01-120		B01-330		B02-10		B02-20		
2x	3,5x45	8x	M4x10	14x		14x		
B02-160		B02-103		B08-40		B08-70		
4x		4x	8x30	2x	5,8x65	2x	Ø8	
							B08-80	
							1x	

BT1-00282 1/1

B01-351		B03-148		B03-149		B03-150		B03-157	Push
8x	M4	1x		1x		1x		1x	
B05-130		B05-185							
1x		4x							

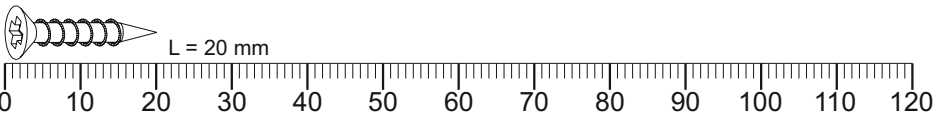

Paket 1/1

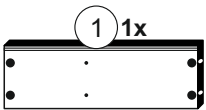

768 x 250
FTx-000621

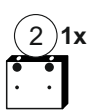

188 x 221
FTx-000620

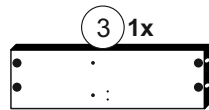

768 x 233
FTx-000619

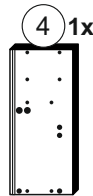

576 x 250
FTx-000615

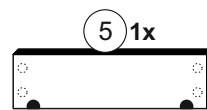

768 x 215
FTx-000616

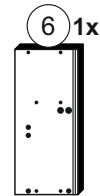

576 x 250
FTx-000614

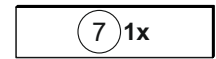

780 x 200
HTR-00457

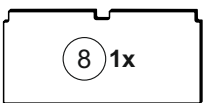

780 x 363
HTR-00456

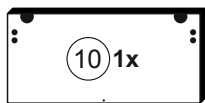

764 x 355
FTx-000618

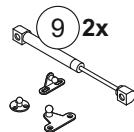

Z07-29



Z08-10

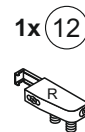

Z08-20

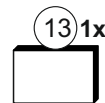

318 x 209
FTx-000617

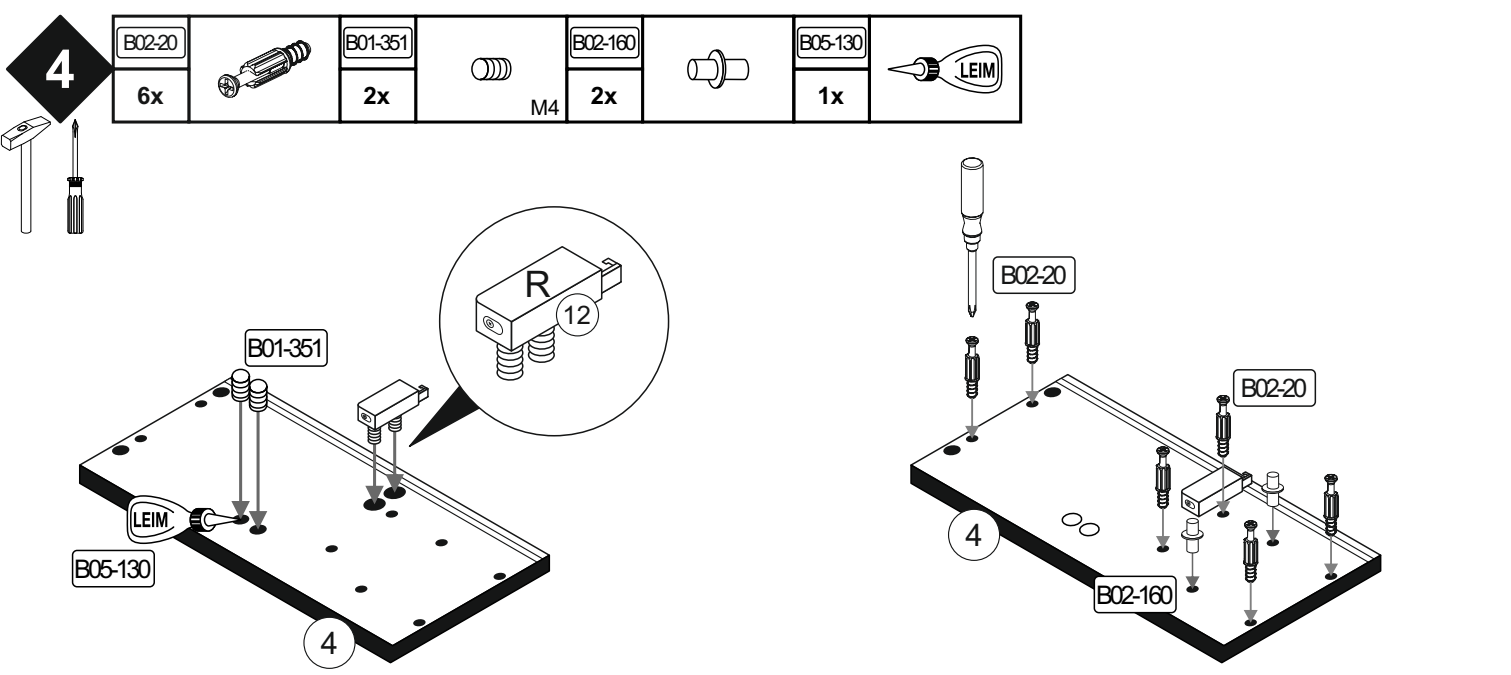
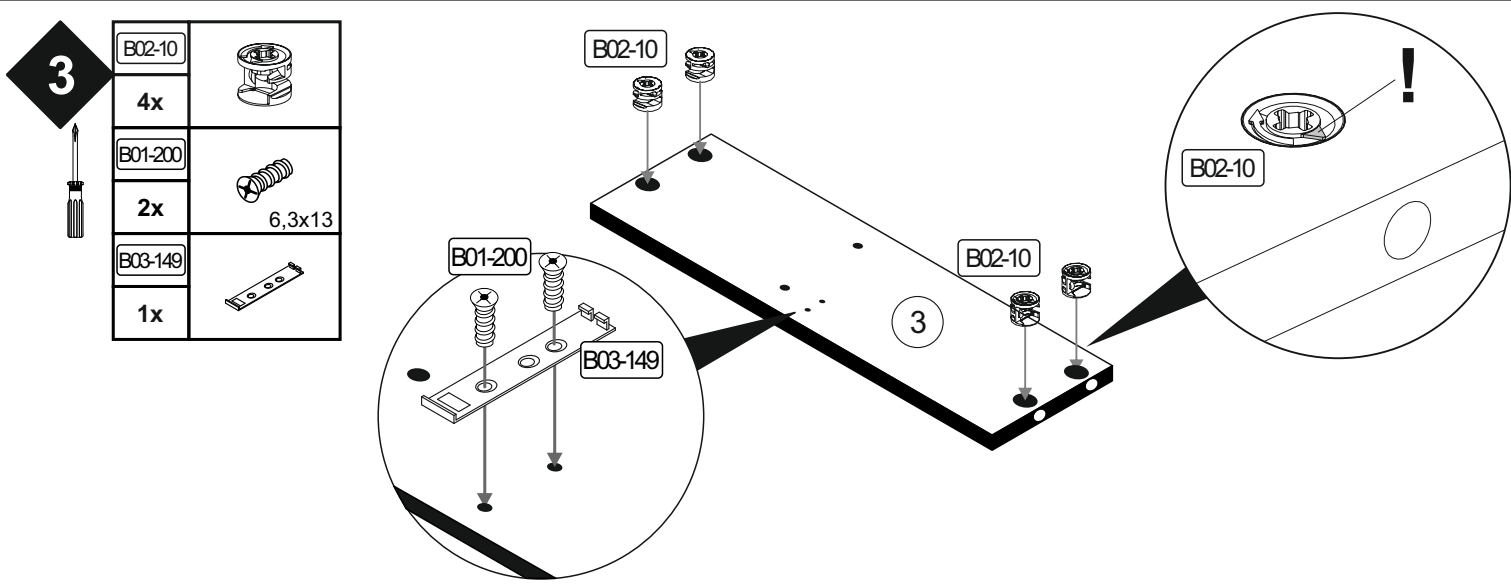
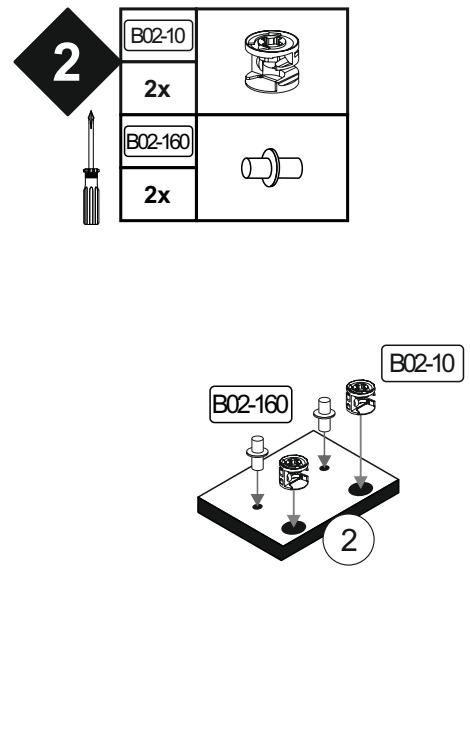
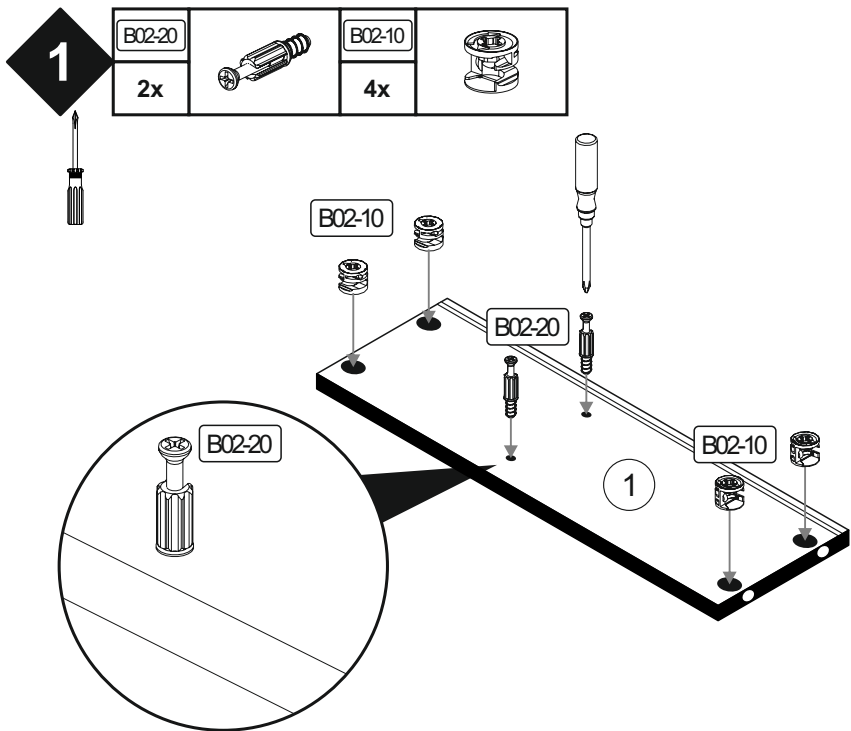

5	B02-20		B01-351		B05-130	
	6x		2x	M4	1x	

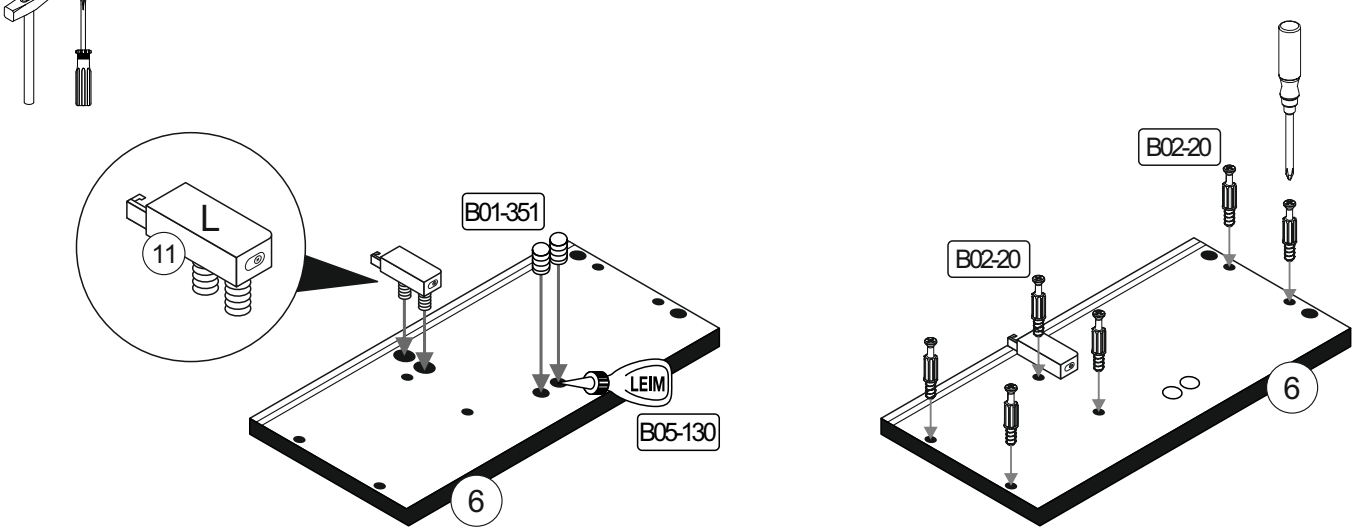

6	B02-10		B03-235		B01-65		B05-130		B02-103	
	4x		2x		6x	3x13	1x		4x	8x30

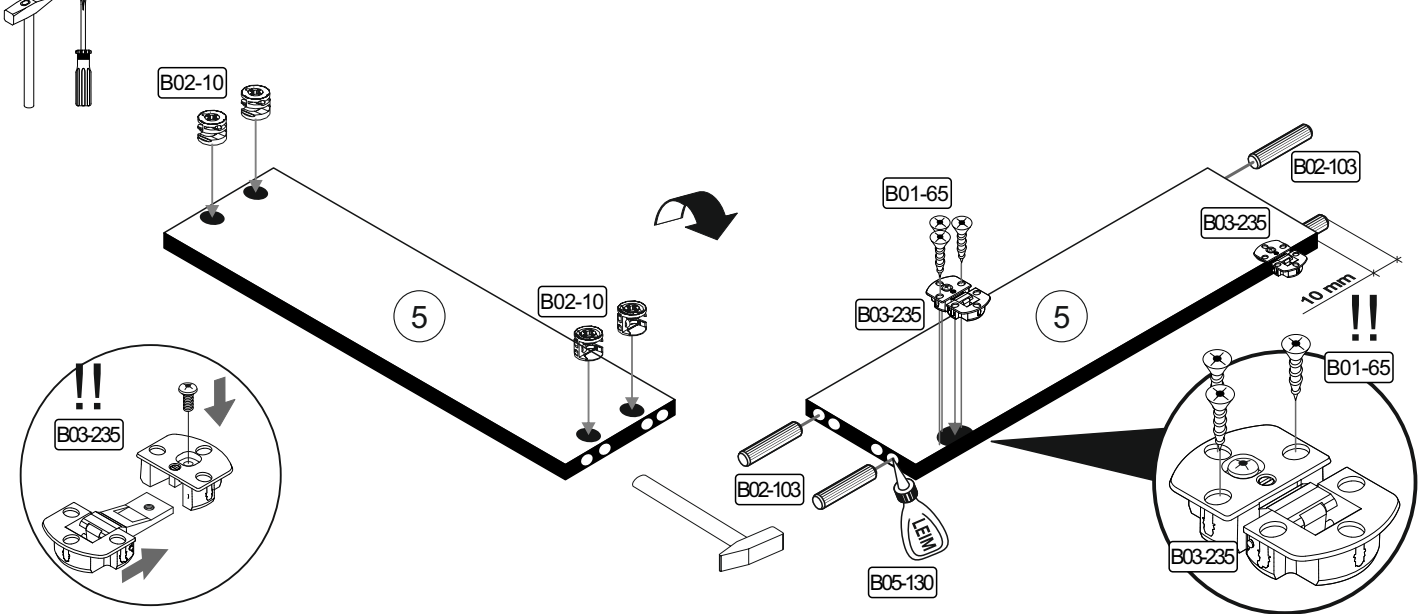

7	B01-351	
	4x	M4
	B03-150	
	1x	
	B01-65	
	1x	3x13
B05-130		
1x		

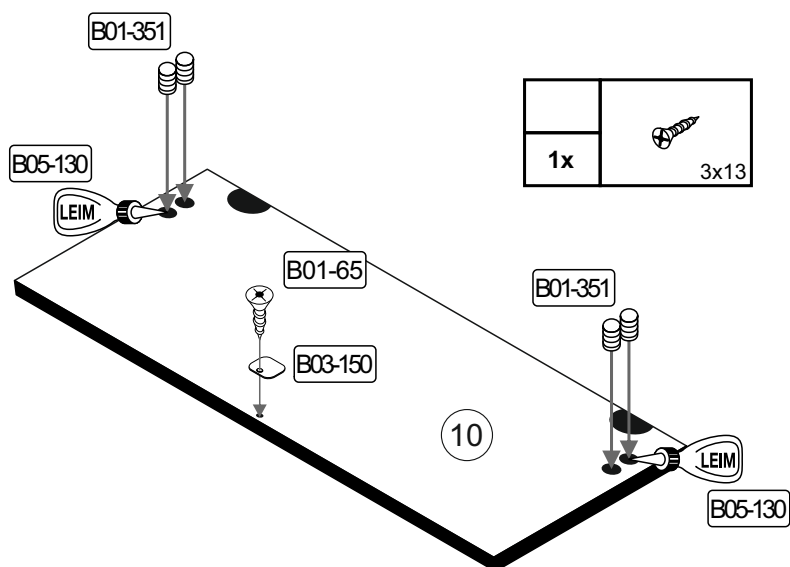

8

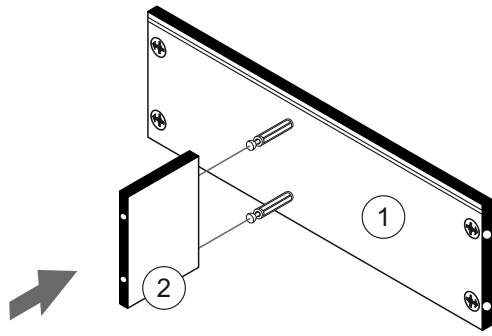

1

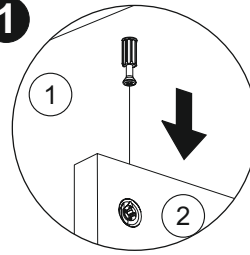

2

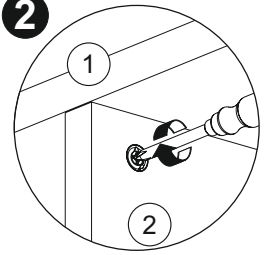

9

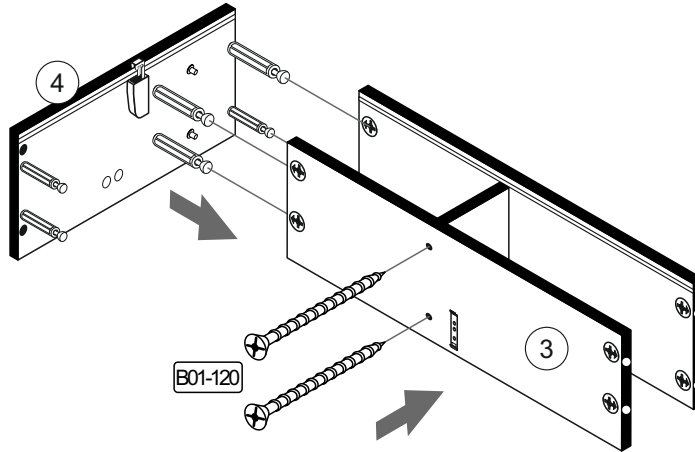
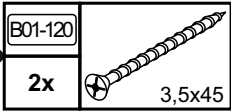

10

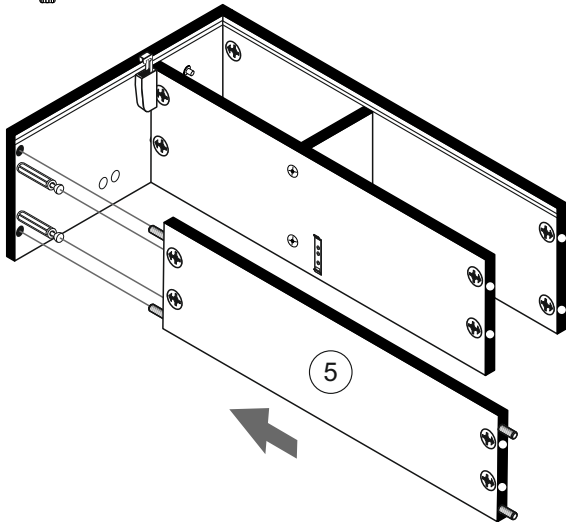

11

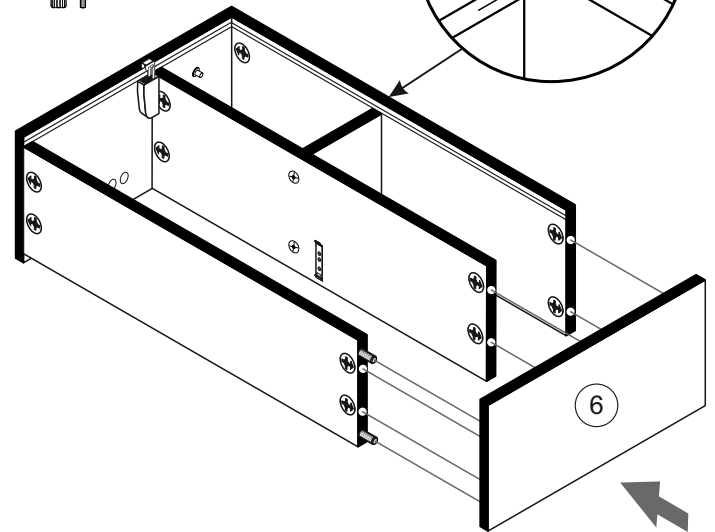
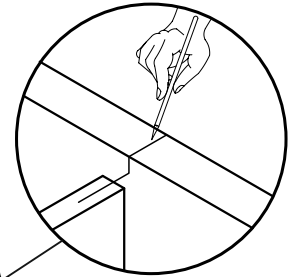

12	B01-30		B05-185		B01-90	
	16x	3x16	4x	4x	4x	3,5x20

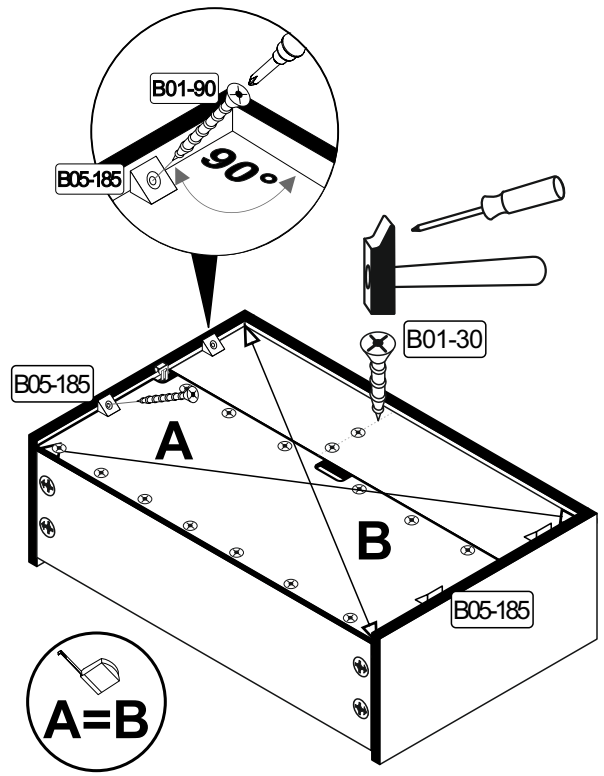
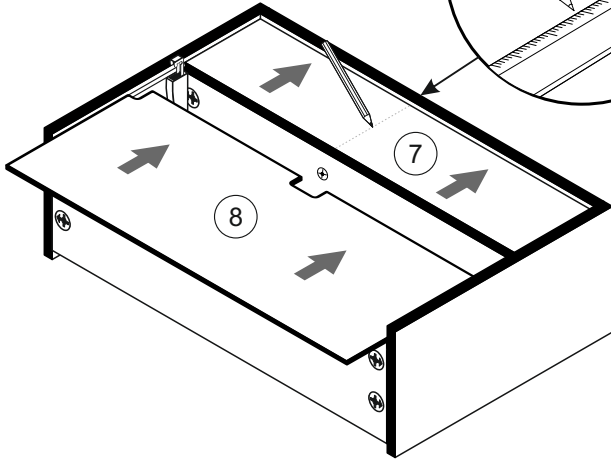
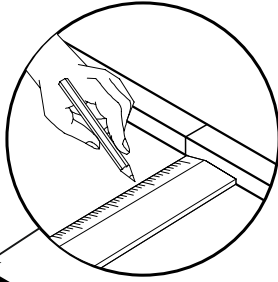
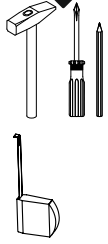

13	B01-65	
	6x	3x13

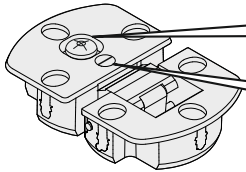
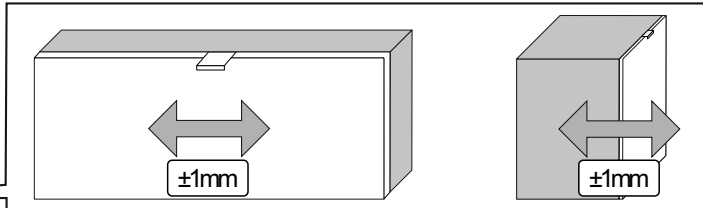

B03-235

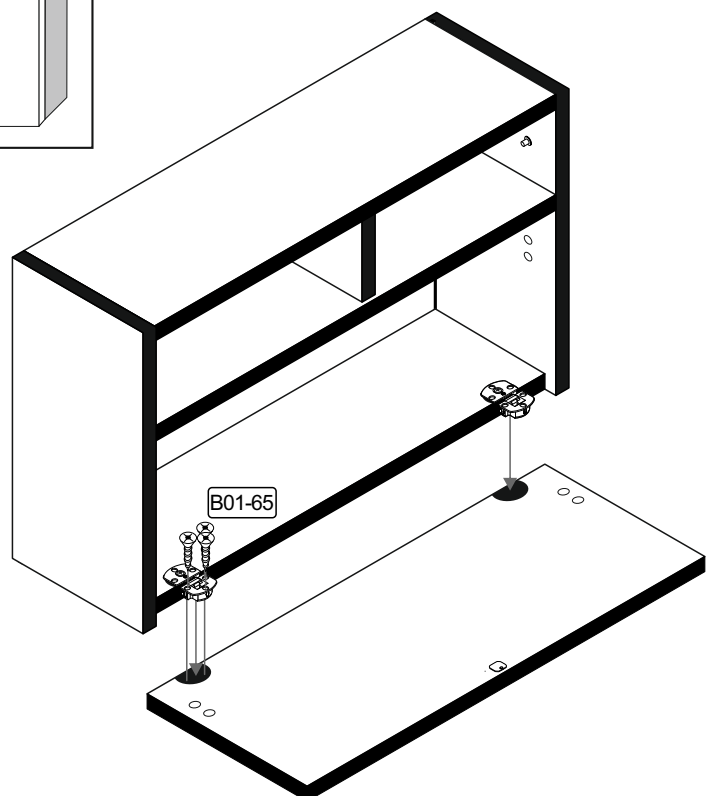
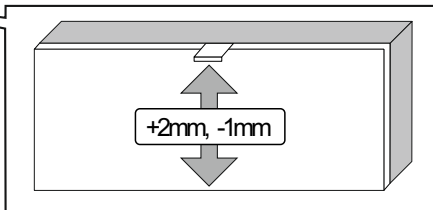

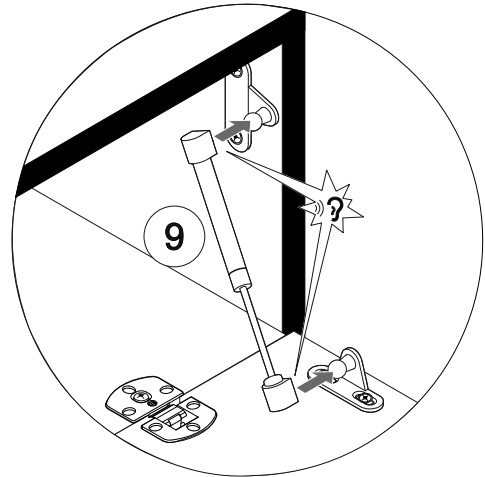
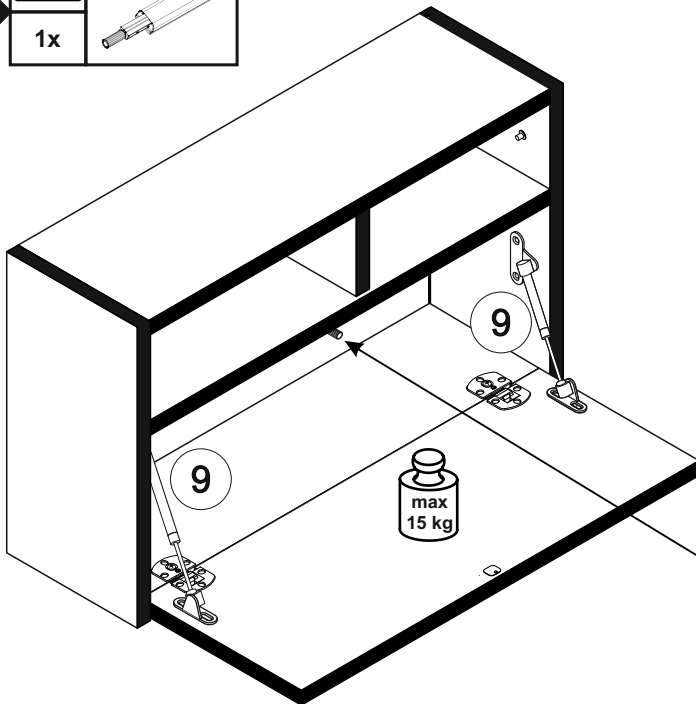
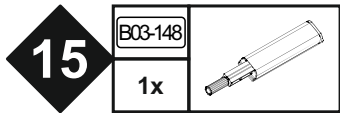
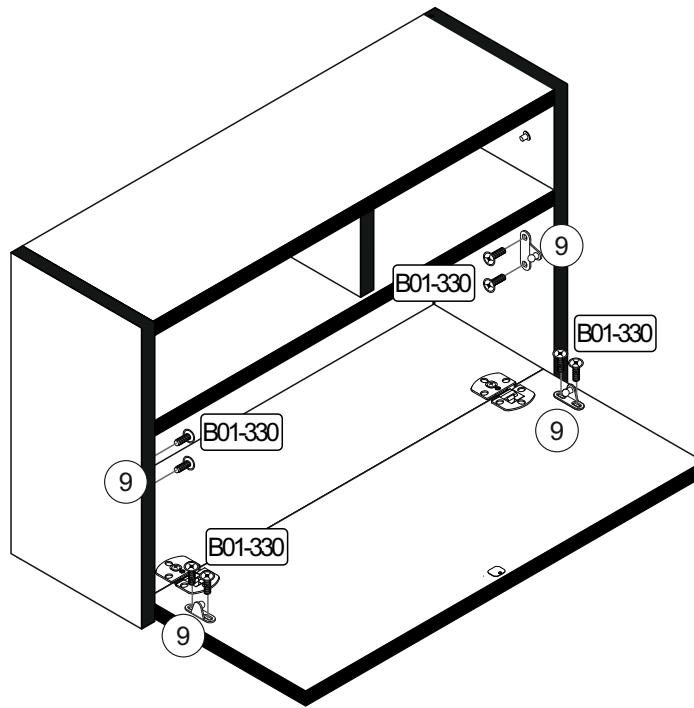
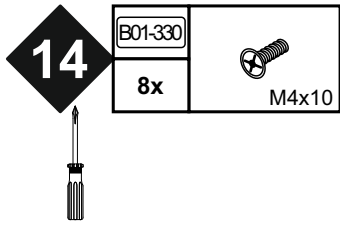

16

B08-40		B08-70	
2x	5.8x65	2x	Ø8
B08-80		B03-157	Push
1x		1x	

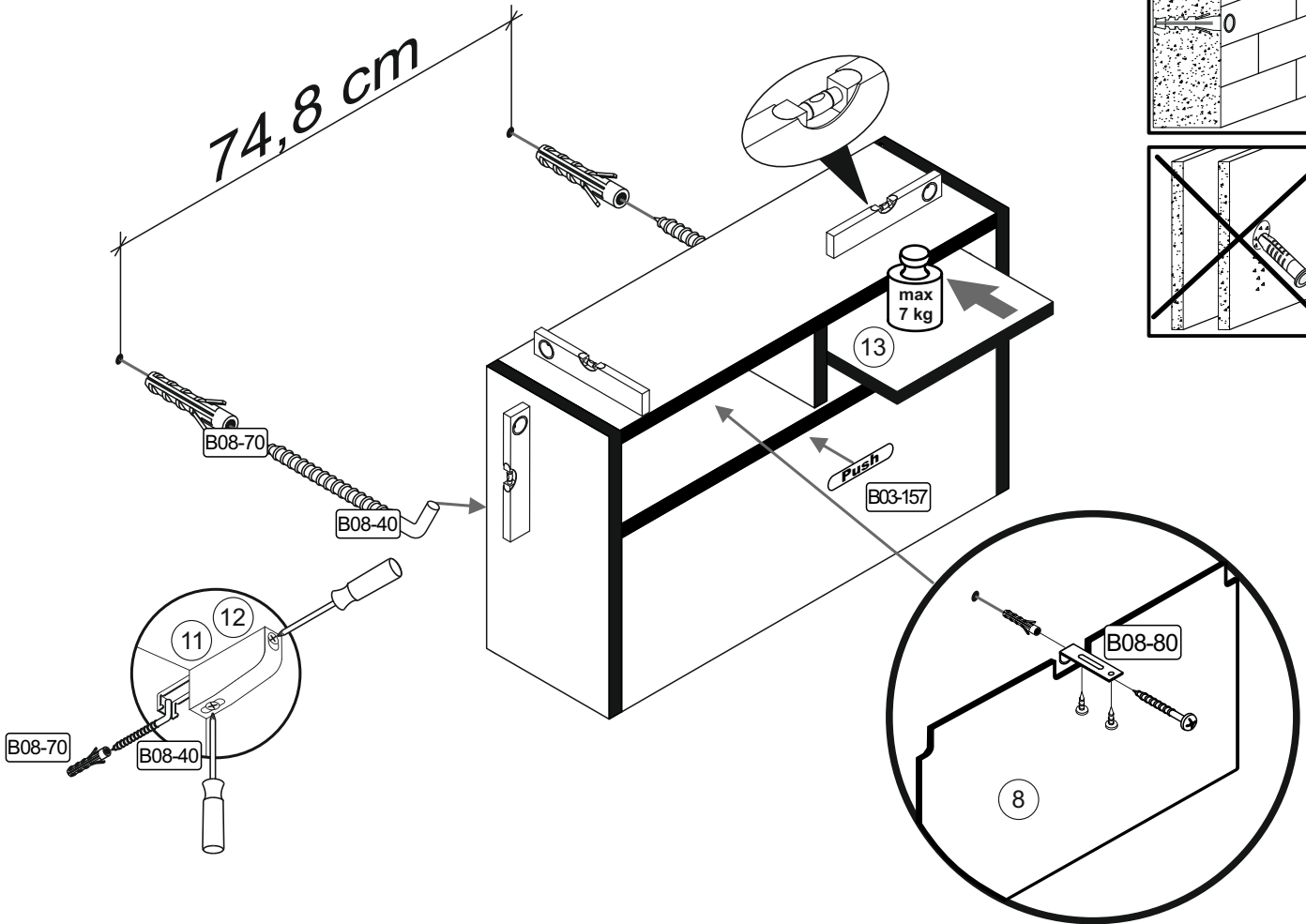
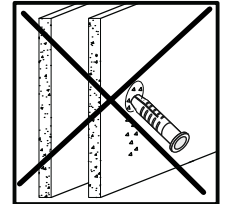
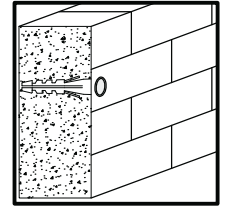
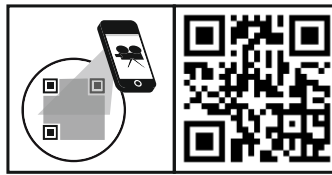

Achtung • Attention • Attenzione • Opgelet • Uwaga • Pozor • Figyelem • Atenție • Dikkat • Внимание	
(D)	Wandbefestigung dient als Kippschutz - unbedingt anbringen! Bei einigen Wandtypen kann ein Spezialdübel erforderlich sein!
(GB)	The wall fastening serves to prevent tipping - be absolutely sure to mount it! For certain wall types, a special wall plug may be necessary!
(FR)	La fixation murale sert de protection contre le basculement – à installer impérativement ! Pour certains types de murs il faut des chevilles spéciales !
(TR)	Duvardaki sabitleme, devrilmeye karşı bir emniyet tedbiridir ve mutlaka monte edilmelidir! Bazı duvar tiplerinde bunun için özel bir dübel gerekli olabilir!
(IT)	Il fissaggio alla parete serve da protezione anti-ribaltamento – attaccarla assolutamente! Per alcune strutture di parete può essere necessario un tassello speciale!
(NL)	Bevestiging aan de muur dient als kantelbescherming – zeker en vast bevestigen! Bij enkele muurtypes is een speciale plug misschien vereist!
(RU)	Обязательно установите крепление на стене во избежание опрокидывания! Для некоторых типов стен может потребоваться специальный дюбель!
(CZ)	Montáž na stěnu slouží jako ochrana proti převrnutí – bezpodmínečně umístěte! U některých typů stěn může být zapotřebí speciální hmoždinka!
(HU)	A terméket a falhoz kel rögzíténi, különben az felborulhat! Egyes faltípusoknál speciális tiplít kell használni!
(RO)	Sistemul de fixare la perete servește ca protecție la răsturnare - de montat obligatoriu! Pentru unele tipuri de perți este posibil să fie necesar un diblu special!
(PL)	Mocowanie do ściany jest jednocześnie zabezpieczeniem przed przewróceniem – koniecznie zamontować! Do niektórych rodzajów ścian konieczne zastosować specjalne kołki mocujące.
(SK)	Upevnenie na stenu slúži ako ochrana proti prevráteniu – bezpodmienečne použiť! Pre niektoré druhy stien môže byť potrebná špeciálna hmoždinka!