

Assembly Instruction/Bauanleitung

Please check that you have all the parts listed before you start assembling, if you do find that something is missing, do not continue assembly, please contact us immediately.



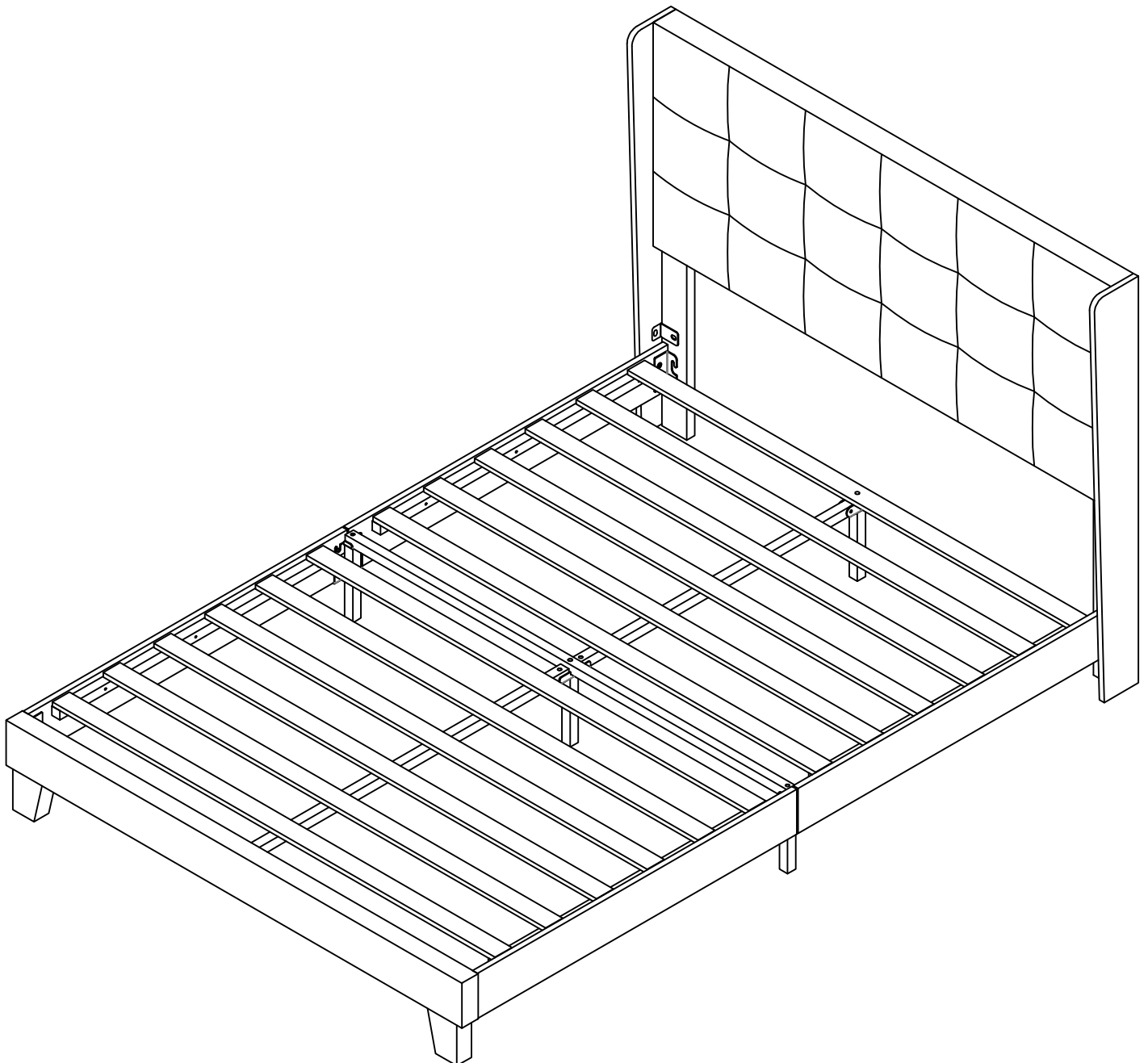

NOTE: Please do not completely tighten all the hardware until the entire assembly is complete!

Bitte überprüfen Sie, ob alle Teile mitgeliefert sind, bevor Sie mit der Montage beginnen. Wenn Sie festlegen, dass etwas fehlt, setzen Sie die Montage nicht fort. Bitte kontaktieren Sie uns sofort.



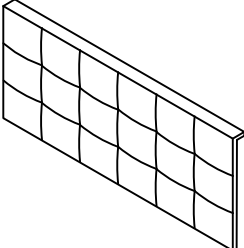
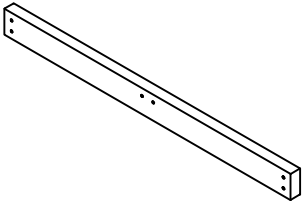
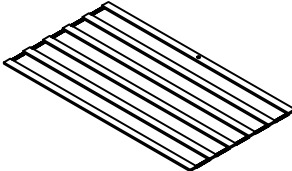
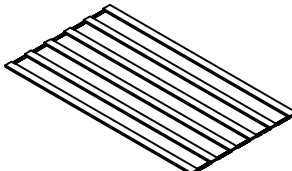
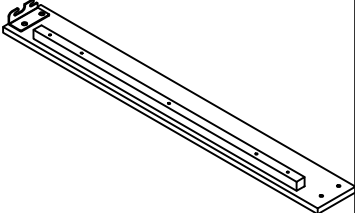
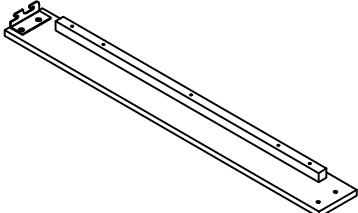

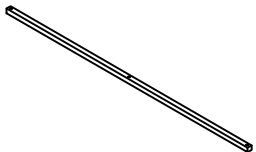
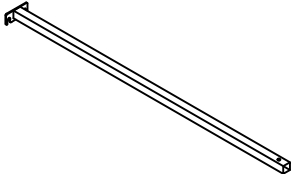
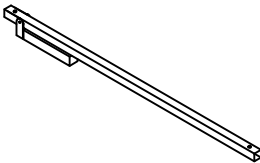
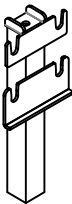
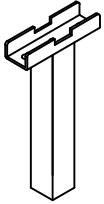
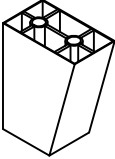
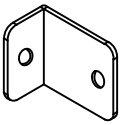

Achtung: Bitte ziehen Sie nicht alle Schrauben fest, bevor die Montage abgeschlossen ist!

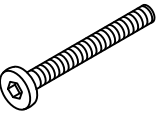

Part list

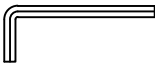
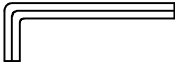

			
A*1PC	B*1PC	C1*1PC	C2*1PC
			
D2*2PCS	D1*2PCS	E*2PCS	F2*1PC
			
F1*1PC	G*1PC	H*1PC	I*1PC
			
J*2PCS	K*1PC	L*2PCS	M*4PCS

Hardware list

			
M6*70MM N*4PCS	M8*50MM O*6PCS	M8*40MM P*4PCS	M8*25MM Q*4PCS
			
M8*18MM R*8PCS	∅22*∅8.5 S*5PCS	M6 T*1PC	M8 U*1PC

step1

Schritt1

O		S	
4PCS		4PCS	

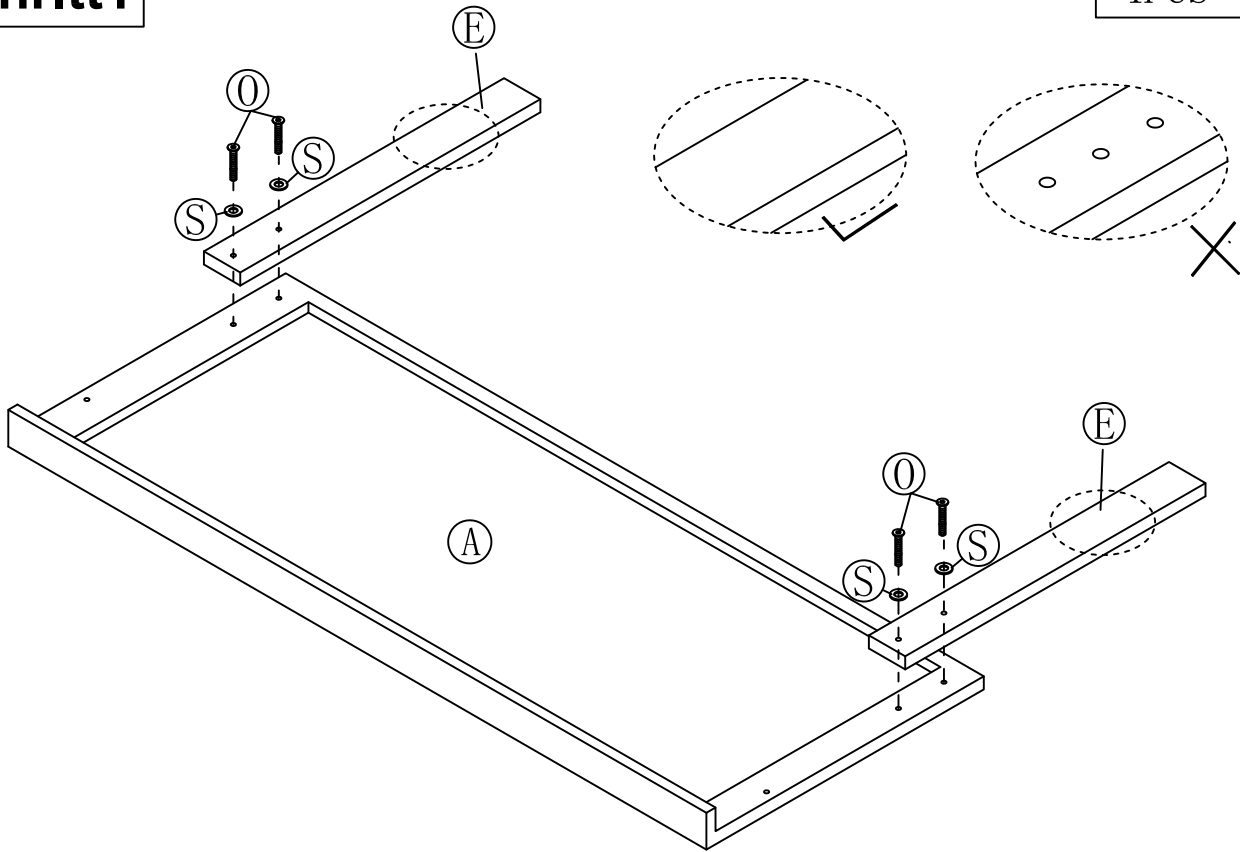

Lassen Sie bitte die Seite mit 3 Löcher des #E nach unten.

step2

Schritt2

Bitte lösen Sie zuerst die am seitlichen Brett vorinstallierten Schrauben, müssen diese aber nicht komplett herausdrehen.

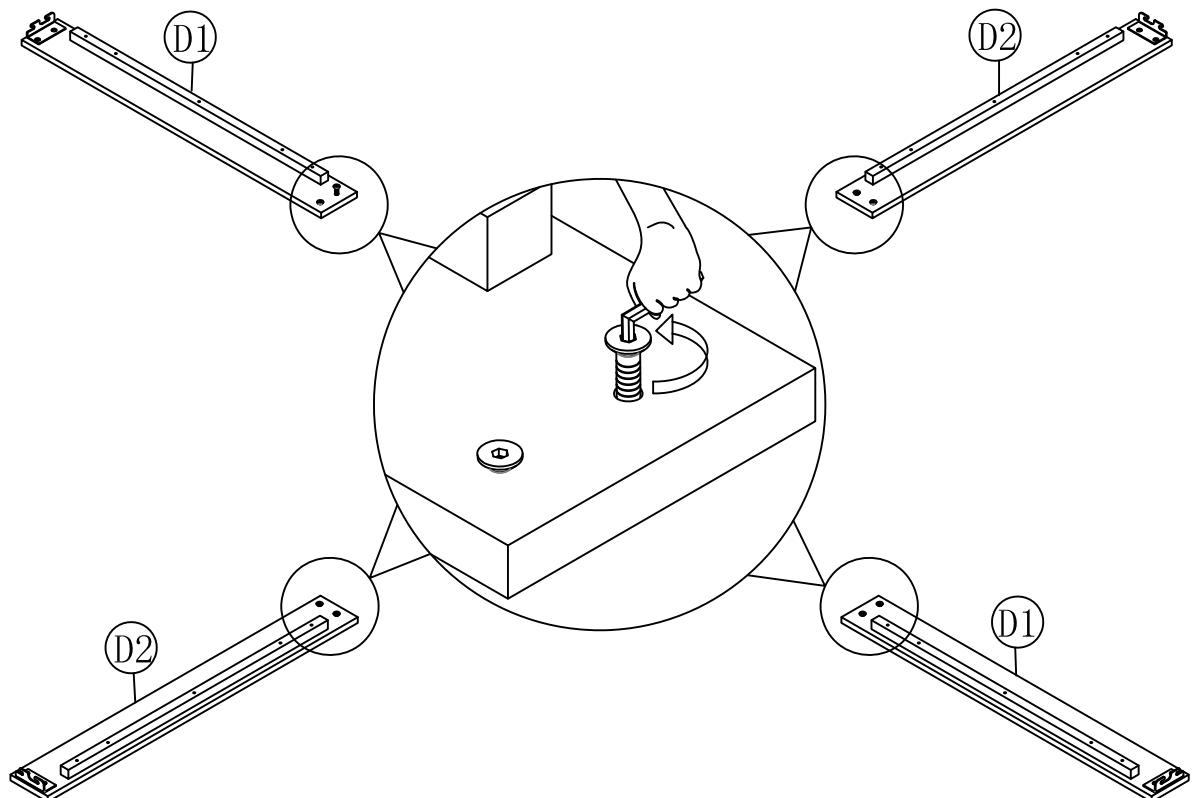

step3

Schritt3

Bitte lösen Sie zuerst die am Fußbrett vorinstallierten Schrauben, müssen diese aber nicht komplett herausdrehen.

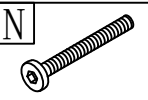

4PCS

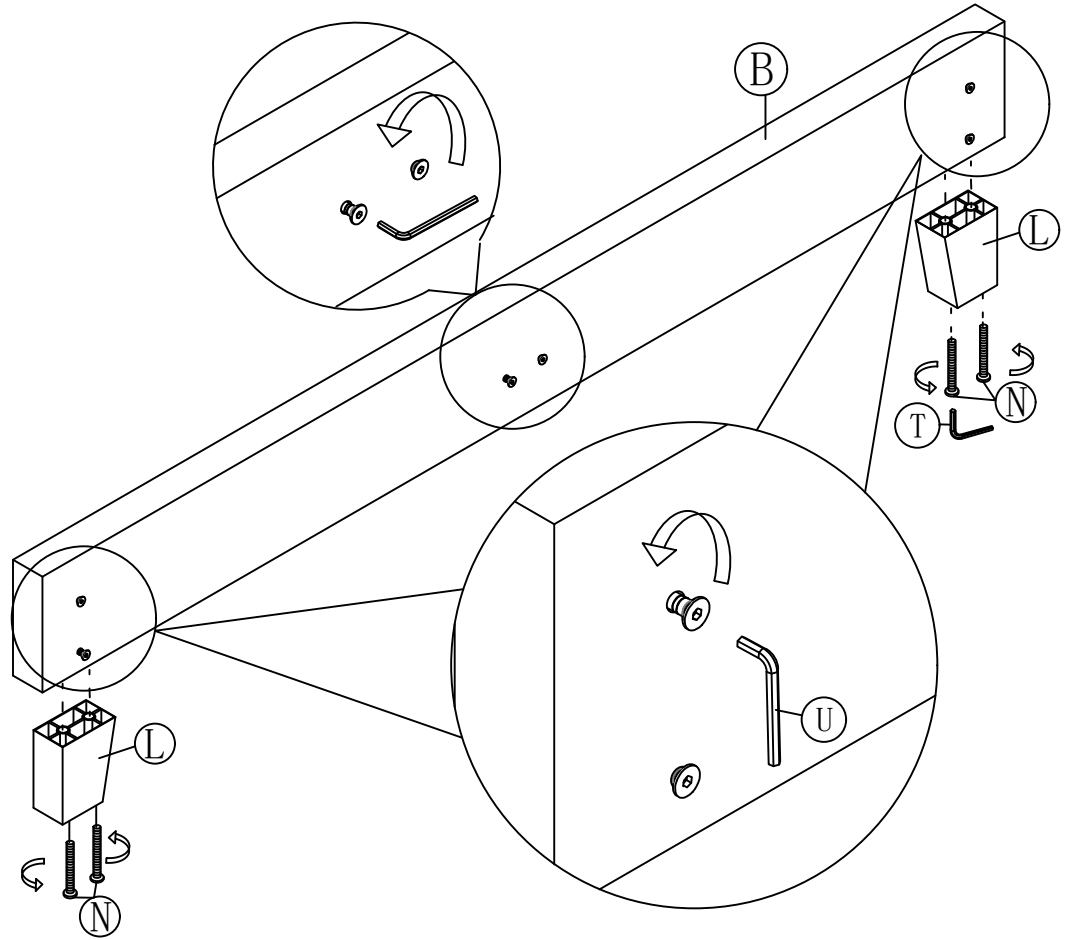

step4

Schritt4

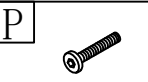

2PCS

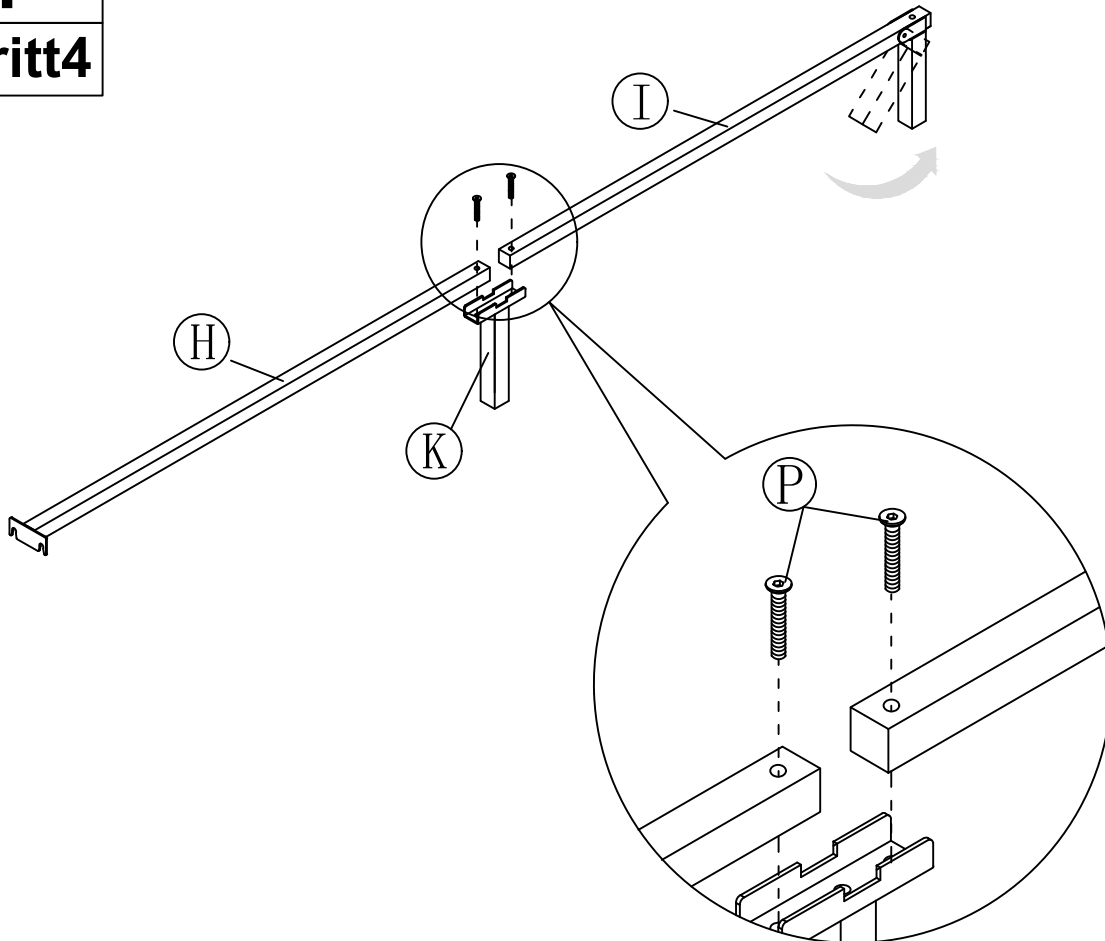

step5

Schritt5

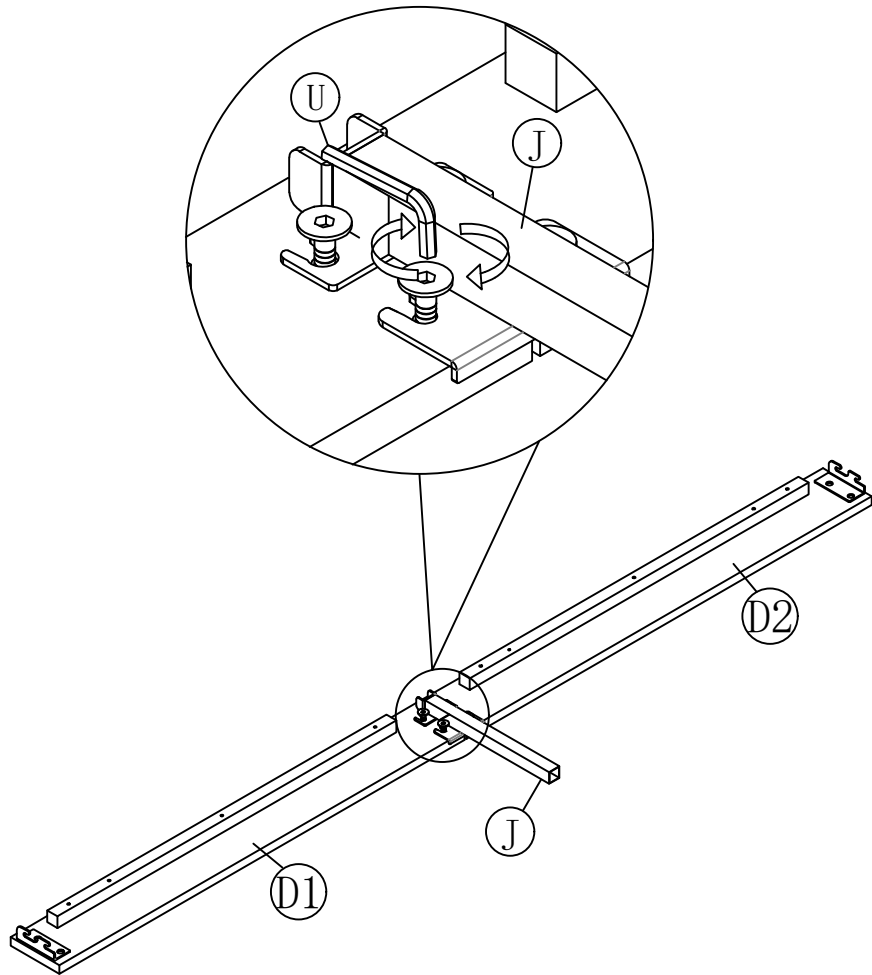

step6

Schritt6

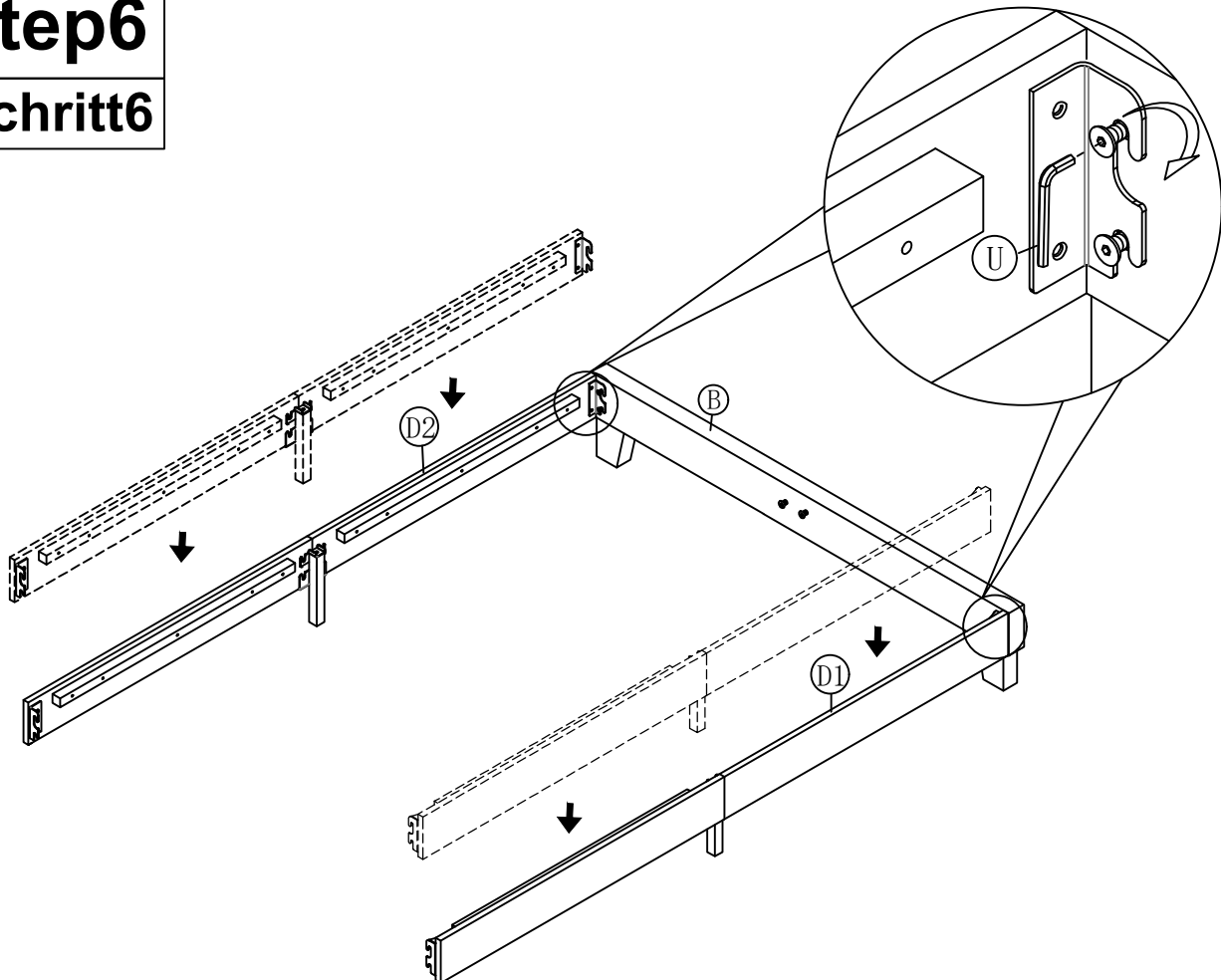

step7

Schritt7

Q



4PCS

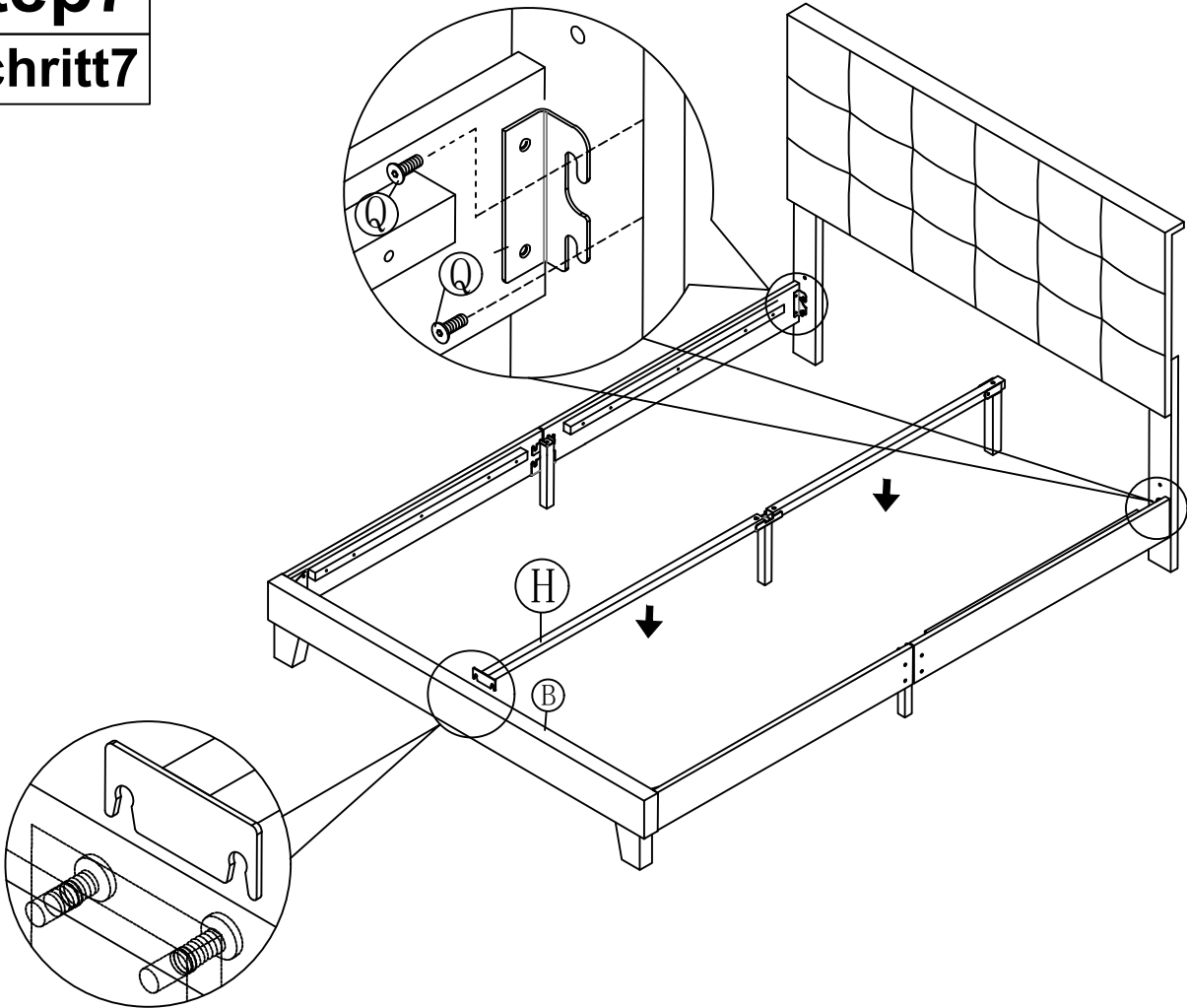

step8

Schritt8

O



1PC

P



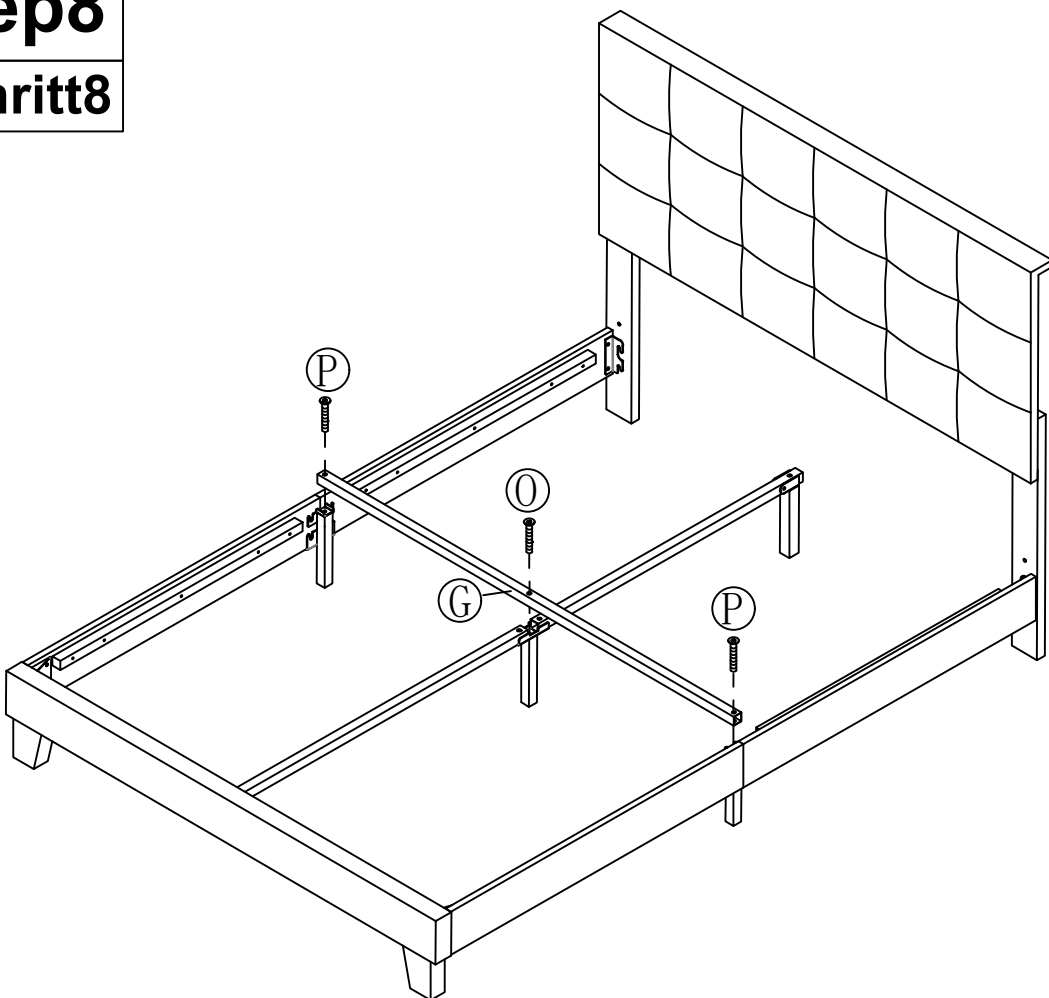

2PCS



step9

Schritt9

O	S
	
1PC	1PC

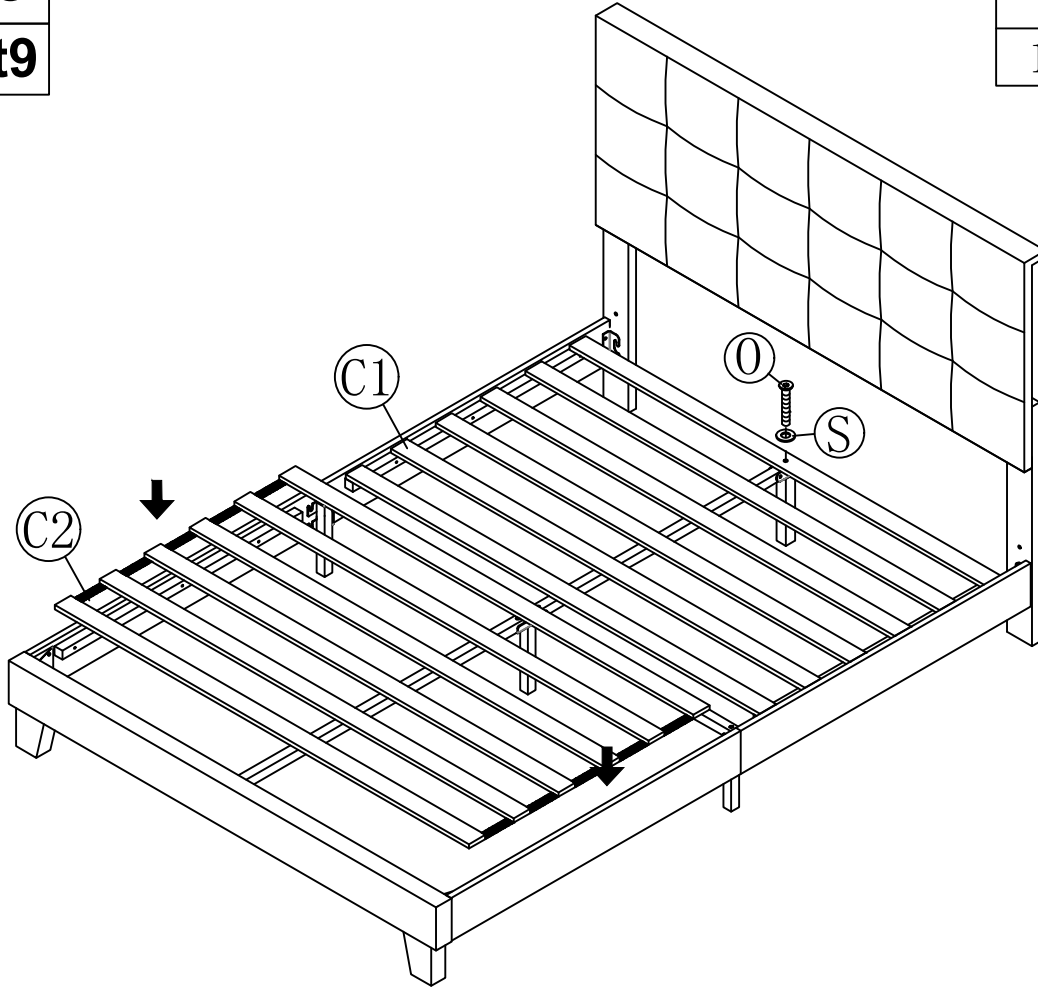

step10

Schritt10

R

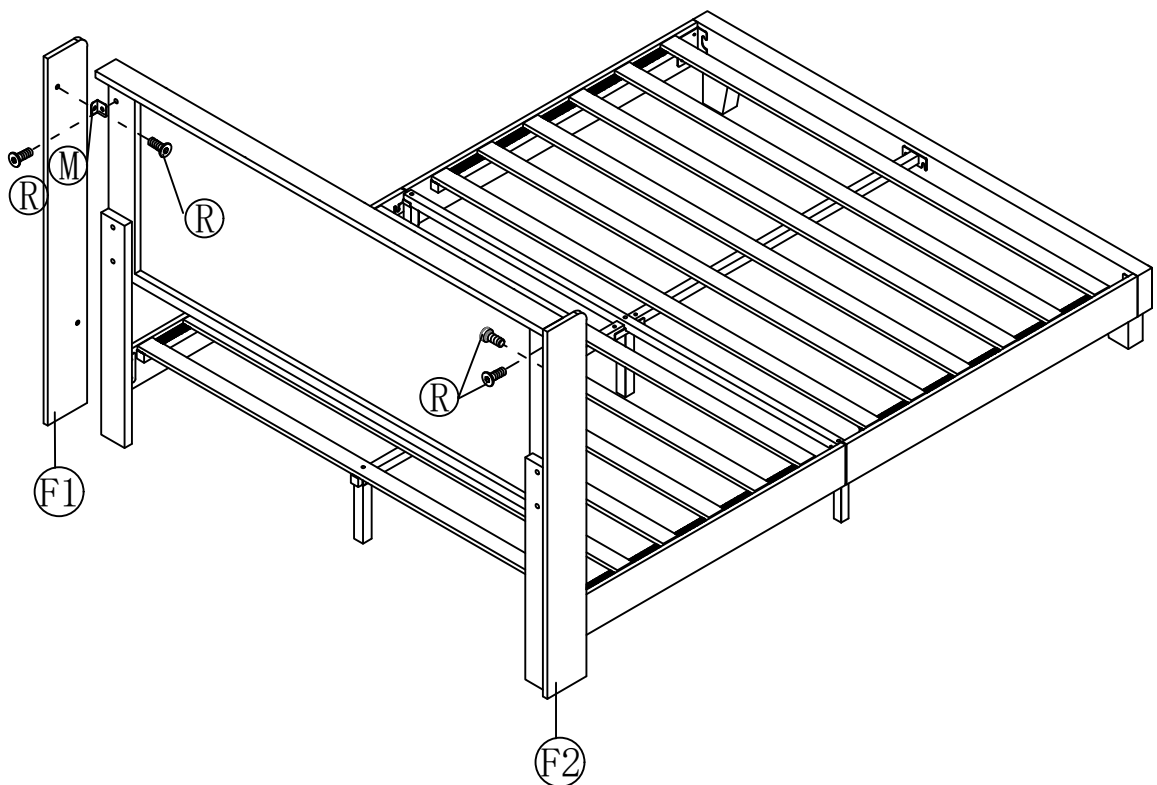
4PCS



step11

Schritt11

R



4PCS

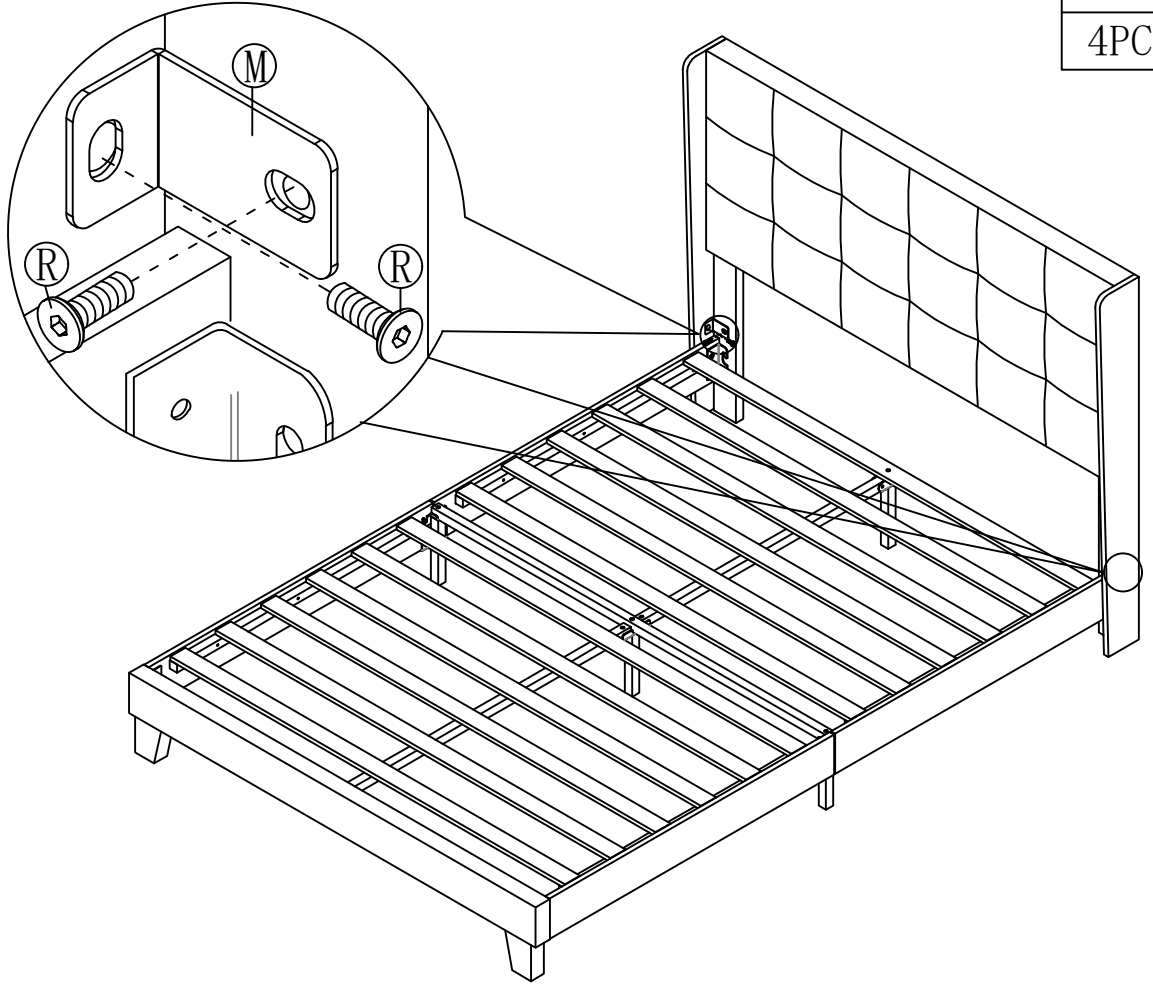

step12

Schritt12

