

Multifunktionale Klettergerüst

BENUTZERHANDBUCH



SKU: WF1973478(N621P197347+ N621P197348)

TESTSTANDARD: EN71

ART.NR: WF1973478A

LESEN SIE DIESE ANLEITUNG UND BEWAHREN SIE SIE FÜR DEN
ZUKÜNFTIGEN GEBRAUCH AUF



[DE]

Warnung: Dieses Produkt ist nicht für Kinder unter 36 Monaten geeignet.

Warnung: Aufgrund der Kleinteile sollten Kinder das Produkt nur unter Aufsicht von Erwachsenen verwenden, um die Gefahr des Verschluckens zu vermeiden. Verschlucken Sie nicht alle Produkte und Teile, einschließlich Kunststoffteile, Netze, Eisenteile und anderes Zubehör.

Warnung: Um die Sicherheit zu gewährleisten, befolgen Sie bitte die Anweisungen zur korrekten Installation und holen Sie sich bei Bedarf professionelle Hilfe.

Warnung: Stellen Sie Möbel nicht in der Nähe von Feuerquellen oder Gegenständen mit hoher Temperatur auf, um Brandgefahr zu vermeiden. Nur für den Innenbereich.

[EN]

Warning: Not suitable for children under 36 months.

Warning: Due to the small parts of the product, children should only use it under adult supervision to avoid a swallowing hazard. Do not swallow all products and parts, including plastic parts, nets, iron parts, and other accessories.

Warning: To ensure safety, please follow the instructions for correct installation and seek professional assistance if necessary.

Warning: Do not place furniture close to fire sources or high-temperature objects to avoid the risk of fire. For indoor use only.

[FR]

Avertissement : Ce produit ne convient pas aux enfants de moins de 36 mois.

Avertissement : En raison des petites pièces du produit, les enfants ne doivent l'utiliser que sous la surveillance d'un adulte afin d'éviter tout risque d'ingestion. N'avez pas tous les produits et pièces, y compris les pièces en plastique, les filets, les pièces en fer et autres accessoires.

Avertissement : Pour garantir la sécurité, veuillez suivre les instructions pour une installation correcte et demander l'aide d'un professionnel si nécessaire.

Avertissement : Ne placez pas les meubles à proximité de sources d'incendie ou d'objets à haute température pour éviter tout risque d'incendie. Pour une utilisation en intérieur uniquement.

[IT]

Attenzione: Questo prodotto non è adatto ai bambini di età inferiore a 36 mesi.

Attenzione: A causa delle piccole parti del prodotto, i bambini devono utilizzarlo solo sotto la supervisione di un adulto per evitare il rischio di soffocamento. A causa delle piccole parti del prodotto, i bambini devono usarlo solo sotto la supervisione di un adulto per evitare il rischio di ingestione. Non ingerire tutti i prodotti e le parti, comprese le parti in plastica, le reti, le parti in ferro e altri accessori.

Attenzione: Per garantire la sicurezza, seguire le istruzioni per una corretta installazione e, se necessario, richiedere assistenza professionale.

Attenzione: Non posizionare i mobili vicino a fonti di fuoco o oggetti ad alta temperatura per evitare il rischio di incendio. Solo per uso interno.

[ES]

Advertencia: Este producto no es adecuado para niños menores de 36 meses.

Advertencia: Debido a las pequeñas piezas del producto, los niños sólo deben utilizarlo bajo la supervisión de un adulto para evitar el riesgo de asfixia. No trague todos los productos y piezas, incluidas las piezas de plástico, las redes, las piezas de hierro y otros accesorios.

Advertencia: Para garantizar la seguridad, siga las instrucciones para una instalación correcta y busque asistencia profesional si es necesario.

Advertencia: No coloque muebles cerca de fuentes de fuego u objetos de alta temperatura para evitar el riesgo de incendio. Solo para uso en interiores.



Importeur	Decobus Handel GmbH		
Adresse	Innungsstraße 9, 21244 Buchholz, Deutschland		
URL	https://www.decobusgroup.de		
Hersteller	Cao County Mingchao Wood Products Co., Ltd.		
Adresse	Jiazhuang Village, Miaokou Administrative Village ,Pulianji Town Cao County, Shandong Province		
Email/URL	mingchaowood@163.com		
<table border="1"><tr><td>EC</td><td>REP</td></tr></table>	EC	REP	Decobus Handel GmbH Innungsstraße 9, 21244 Buchholz, Deutschland https://www.decobusgroup.de
EC	REP		

SICHERHEIT & WARNUNGEN

MONTAGE DURCH ERWACHSENE ERFORDERLICH.

- Bewahren Sie diese Anleitung zum späteren Nachschlagen auf.
- Dieses Produkt ist nur für den Gebrauch in Innenräumen, in der Familie und im Haushalt bestimmt.
- Stellen Sie das Produkt auf eine ebene Fläche, die mindestens 200 cm von einem Zaun, einem Gebäude, oberirdischen Ästen oder elektrischen Leitungen entfernt ist, von einem Zaun, einem Gebäude, oberirdischen Ästen, einer Wäscheleine oder einer elektrischen Leitung entfernt ist. Dieses Produkt sollte nicht in der Nähe von Möbeln aufgestellt werden, die bei einem Sturz Verletzungen verursachen könnten.
- Stellen Sie sicher, dass der Aufstellbereich belüftet ist.
- Verwenden Sie das Produkt nicht, wenn es beschädigt oder defekt ist. Wenn es beschädigt oder defekt ist, wenden Sie sich bitte an einen qualifizierten Techniker.
- Überprüfen Sie, ob alle Teile richtig zusammengebaut und stabil sind, bevor Sie sie verwenden. Defekte Teile müssen sofort ausgetauscht werden, da sie den Betrieb und die Sicherheit des Produkts beeinträchtigen können.
- Wenn die Temperaturen unter den Gefrierpunkt (0° C/32° F) sinken, wird die Verwendung dieses Produkts im Freien nicht empfohlen. Bei großer Kälte verlieren Kunststoffe ihre Elastizität und können durch einen Schlag spröde werden und reißen. Das Produkt an einem wärmeren und geschützten Ort lagern.
- Von Feuer oder anderen Zündquellen fernhalten.
- Das Verpackungsmaterial ist kein Spielzeug, bewahren Sie es außerhalb der Reichweite von Kindern auf.
- Bringen Sie Kindern den richtigen Umgang mit diesem Produkt bei: nur, nachdem Sie es richtig zusammengebaut und installiert haben, und nicht auf andere Weise als vorgesehen und richtig installiert haben, und nicht auf andere Weise als vorgesehen.
- Kinder angemessen kleiden: Erlauben Sie Kindern nicht, lockere Kleidung zu tragen, einschließlich Ponchos, Schals und Kleidung mit Kordeln. Erlauben Sie Kindern nicht, lockere Kleidung zu tragen, einschließlich Ponchos, Schals und Kleidung mit Kordeln. Es sollten stets gut sitzende Schuhe getragen werden.
- Vermeiden Sie es, das Gerät in die pralle Sonne zu stellen, da die heißen Oberflächen schwere Verbrennungen verursachen können.
- Es ist sehr wichtig, dass die folgenden Anforderungen regelmäßig oder zu Beginn jeder Saison während der Nutzung erfüllt werden.
 - Prüfen Sie alle Schrauben und Muttern auf scharfe Kanten und ersetzen Sie sie gegebenenfalls.
 - Prüfen Sie, ob alle Schrauben fest angezogen sind, und ziehen Sie sie ggf. nach.
 - bitte regelmäßig mit einem trockenen Tuch abwischen.

Hinweis:

1. Die Verwendung im Freien ist verboten!
2. Kein Verschlucken!
3. Kinder müssen von einem Erwachsenen beaufsichtigt werden!

BITTE NICHT ZUM LADEN ZURÜCKGEBEN











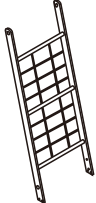

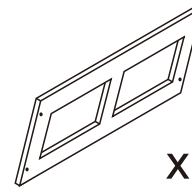

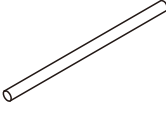
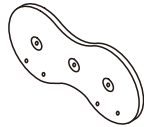
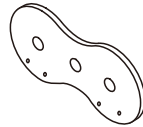
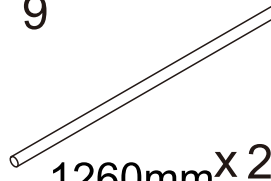
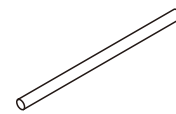
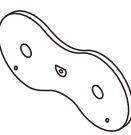
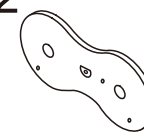
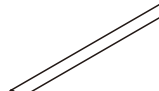

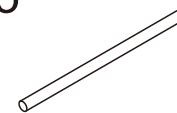

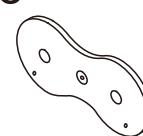
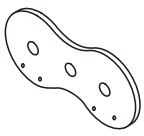

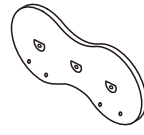

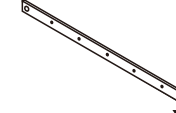
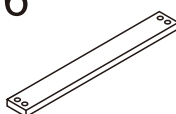
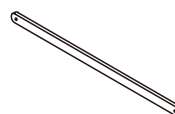
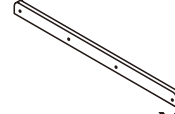
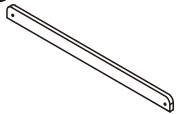



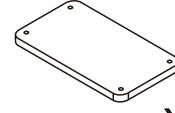

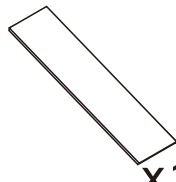
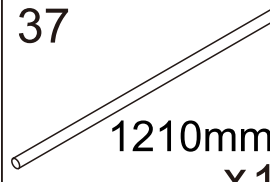

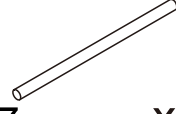
Bitte geben Sie dieses Produkt nicht an den Händler zurück!!

Wir können Ihnen in jeder Hinsicht behilflich sein.

Wenn Sie feststellen, dass Sie Probleme beim Zusammenbau oder haben
Sollten Teile fehlen oder beschädigt sein, wenden Sie sich bitte an den Verkäufer.

STÜCKLISTE

1  x1	2  x1	3  x1	4  x3	5  x2
6  307mm x13	7  x1	8  x1	9  1260mm x2	10  406mm x2
11  x1	12  x1	13  798mm x3	14  x1	15  387mm x3
16  x1	17  x1	18  x1	19  x1	20  x1
21  x1	22  x1	23  x2	24  x2	25  x2
26  x4	27  x2	28  x1	29  x1	30  x1
31  x2	32  x2	33  x1	34  x2	35  x2
36  x1	37  1210mm x1	38  x2	39  357mm x1	
A  M5x30mm x28	B  M7x50MM x56	C  M6 x 50MM x4	D  M7x70MM x4	E  M6x50mm x10
F  M6x35MM x8	G  M6 x 35MM x2	H  x1		

INSTALLATION

Schritt 1

Verbinden Sie 17,3,4 mit A.

17	3	4
A		

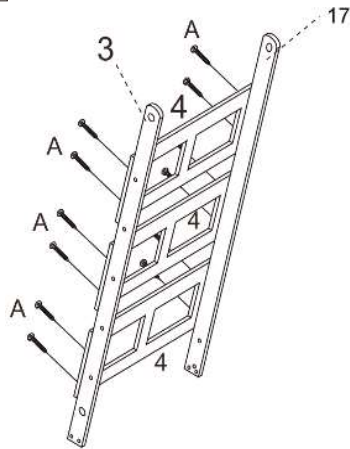

Schritt 2

Legen Sie 1 und 17 zwischen 7 und 8 und sichern Sie sie mit E.

7	8	1	17
E			

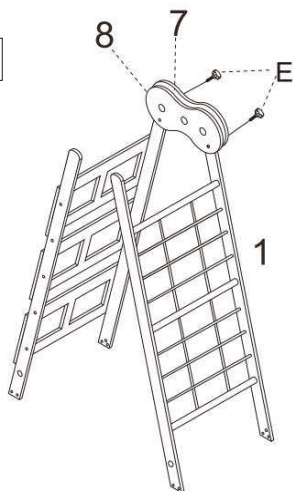

Schritt 3

Stecken Sie 10 in die Löcher in der Mitte von 7 und 8 und befestigen Sie es mit B. Platzieren Sie 11 zwischen 3 und 1 und befestigen Sie 10 und 11 mit B.

7	8	10
11	3	1
B		

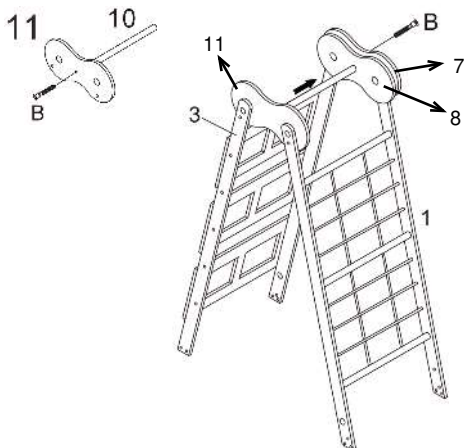

Schritt 4

Verbinde 3 und 11, 1 und 11 mit 9. Befestigung mit B Schrauben.

3	1	11
9	B	

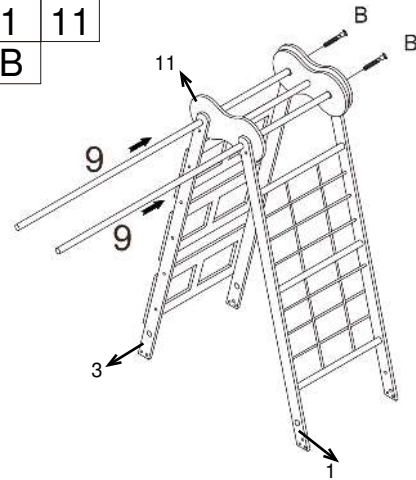

Schritt 5

Befestigen Sie 12 an beiden 9. und stecken Sie 39 in das Loch in der Mitte von 12 und sichern Sie es mit B.

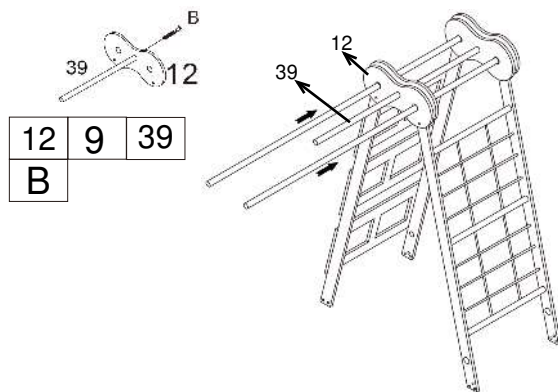

Schritt 6

Fixieren Sie 11 und 12 auf 3 und 1 mit E Schrauben.

3	1	11
12	17	37
E	B	

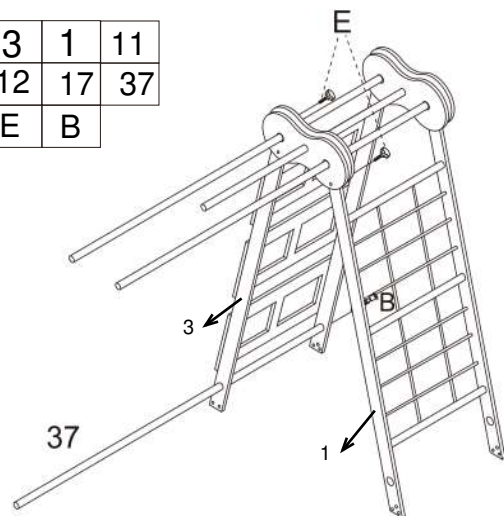

INSTALLATION

Schritt 7

Befestige zwei 13er mit B an 3.

13	3	B
----	---	---

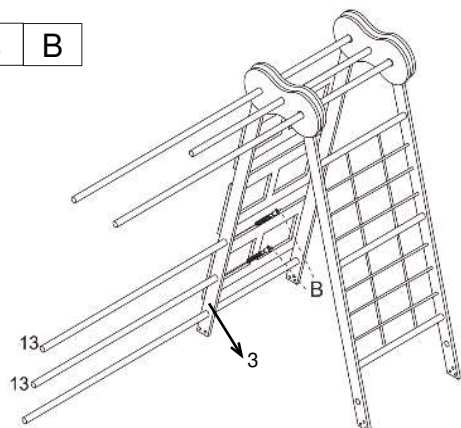

Schritt 10

Lassen Sie die beiden 5er durch die 9 gehen. Lass die 13 durch die 1 gehen und sichere die Enden von 1 und 13 mit B.

5	9	13
1	B	

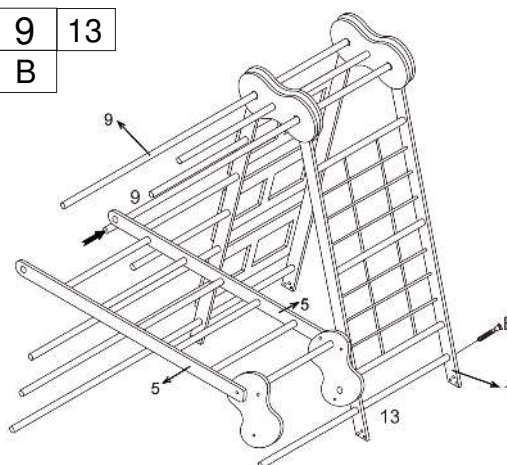

Schritt 8

Drei 15er mit B an 3 befestigen.

15	3	B
----	---	---

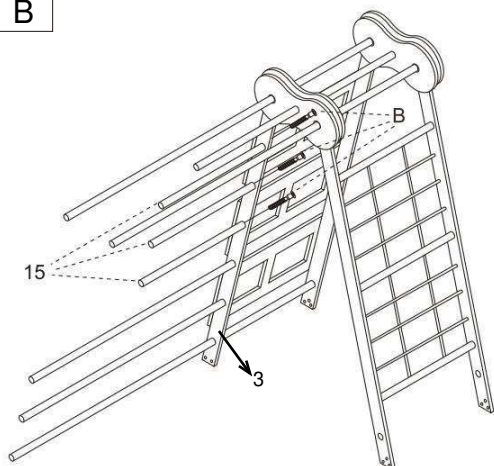

Schritt 11

Lassen Sie die 14 durch die beiden 9er und gegen die Seite der 3 9 er gehen und sichern Sie die 3 9 er und 14er mit B. Dann führen Sie die 16 und 2 durch die 9er und sichern Sie die 5er, 12er und 14er mit F. Führen Sie die 13 durch die 16er und sichern Sie die 15er und 16er zusammen mit B. Fixieren Sie 13 und 2 mit B.

14	9	39	13
16	2	15	5
12	B	F	

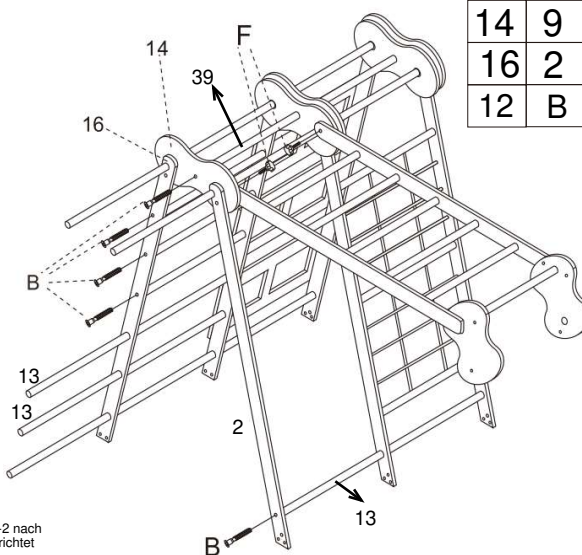

Schritt 9

Führen Sie die Enden einer 6 in den mittleren Schlitz 23 ein und platzieren Sie sie zwischen den beiden 5ern (nicht einschrauben!) Die 6 wird wie gezeigt zwischen den beiden 5ern eingesetzt.

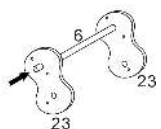

6	23	5	B
---	----	---	---

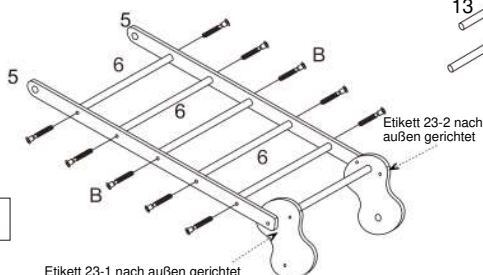

13

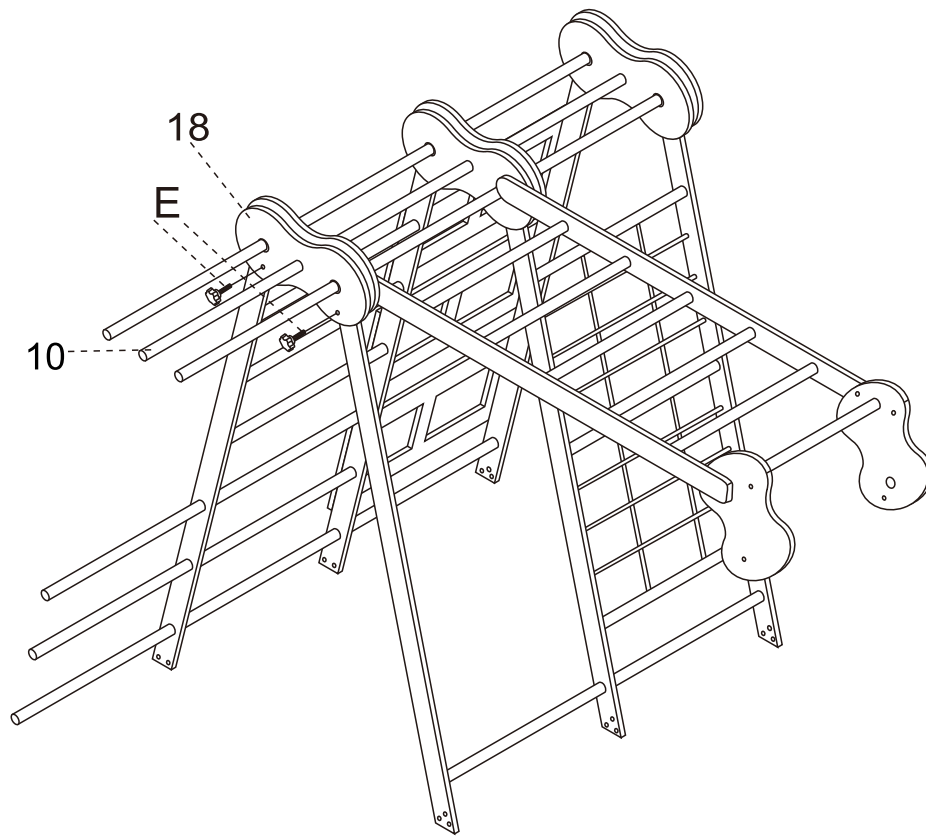

14

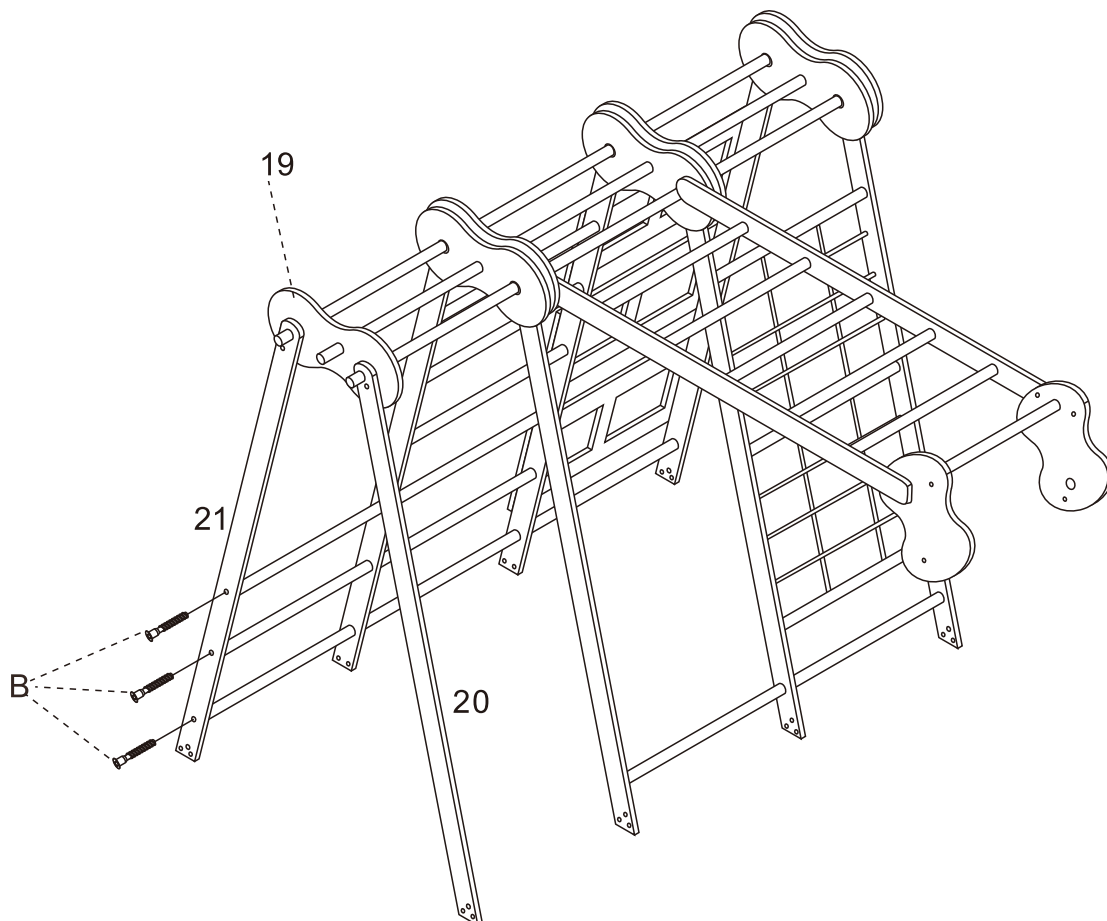

INSTALLATION

10	18
9	B

Schritt 12

Fixiere 10 und 18 mit B. Lass 18 durch beide 9en gehen.

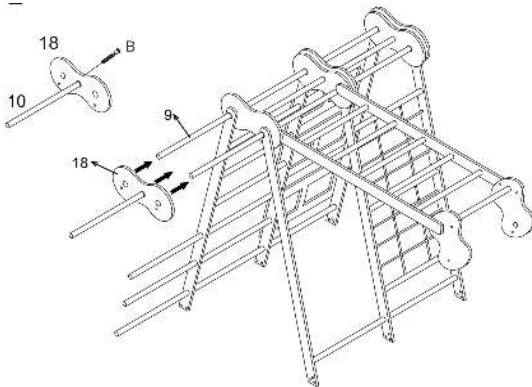

Schritt 15

Führen Sie 22 durch die beiden 9en und 10. Sichern Sie 20, 21, 22 mit E. Befestigen Sie 22 mit B an 9 und 10.

22	9	10	20
21	E		

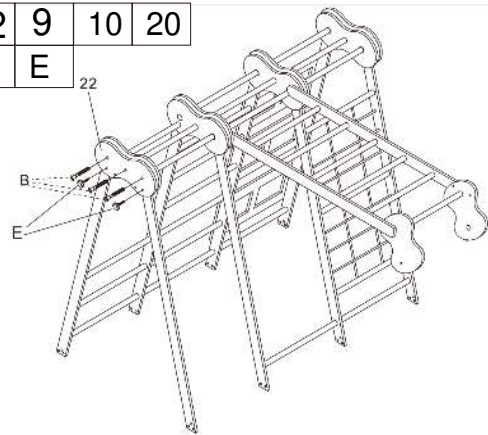

Schritt 13

Befestigen Sie 18 und 16 und 2 mit E.

18	16
2	E

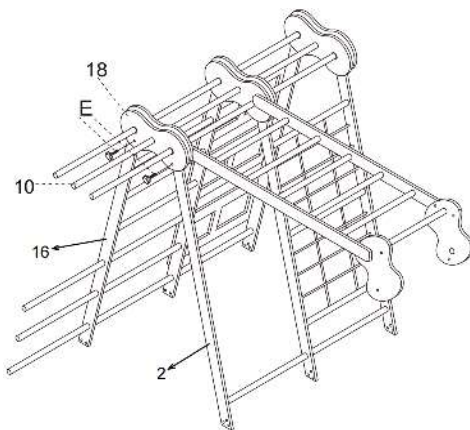

Schritt 16

Setzen Sie die andere 6 zwischen die beiden 23er ein.

23	6
----	---

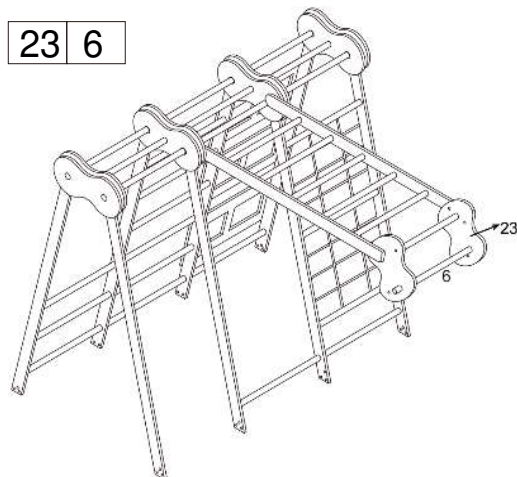

Schritt 14

Gib 19 durch die beiden 9en und 10en. Lass 20 und 21 durch 9 gehen. Fixiere 21 und 13, 37 mit B.

19	9	10	20
21	13	37	B

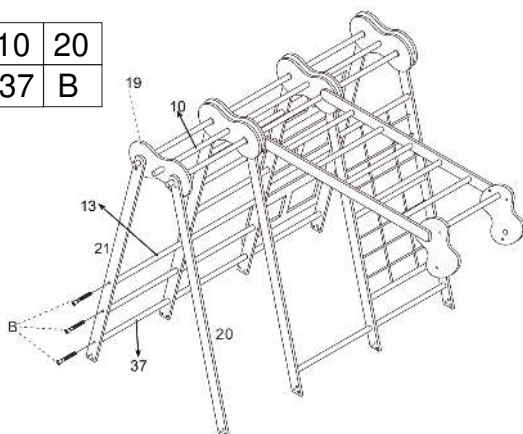

Schritt 17

Behoben mit B 6s und 25s.

6	25	B
---	----	---

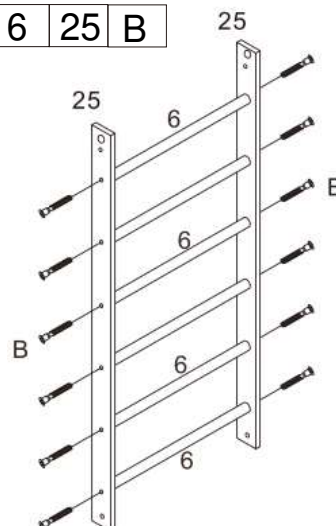

INSTALLATION

Schritt 18

Lassen Sie die 25er auf der Außenseite der 23er liegen, dann legen Sie die 24er auf die Außenseite der 25er. Befestige 6 und 24 mit D. Befestige 24 und 5 mit C.

25	23	24	6	5
C	D			

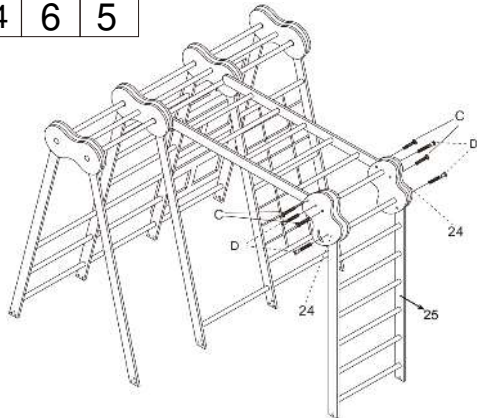

Schritt 19

E in 24 einfügen.

E	24
---	----

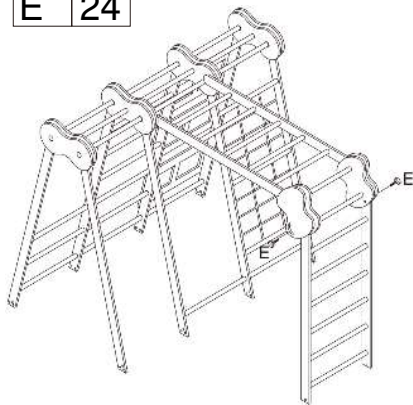

Schritt 20

Fixiere 26 und 1, 3, 16, 17, 20, 21 mit A.

26	1	2	3
16	17	20	21
A			

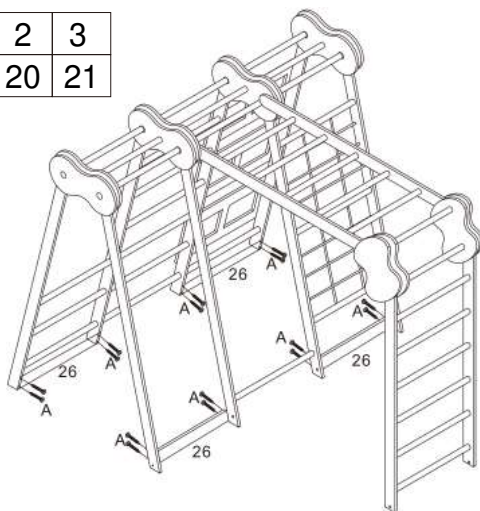

Schritt 21

Fix 28 und 21, 20 mit F. Fix 29 und 1, 17 mit F.

28	20	21	29
1	17	F	

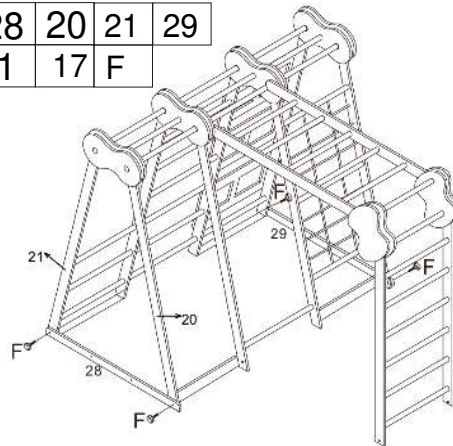

Schritt 22

25s und 27s mit G fixieren. 27s und 1, 2 mit F fixieren.

25	27	1
2	F	G

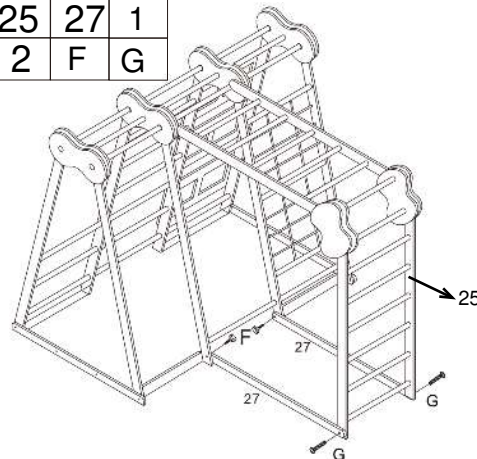

Schritt 23

Befestigen Sie 35 und 36 mit B.

35	36	B
----	----	---

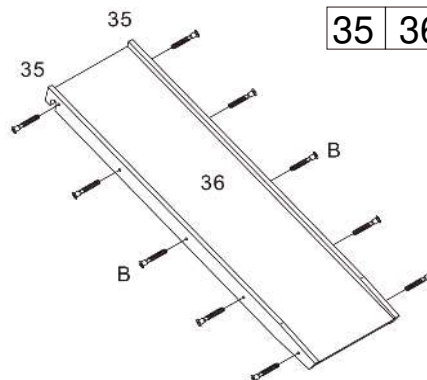

INSTALLATION

Schritt 24

Setzen Sie 36 auf den Rundstab und führen Sie 30 durch die beiden verbleibenden Löcher in 22 und befestigen Sie es.

36 | 30 | 22

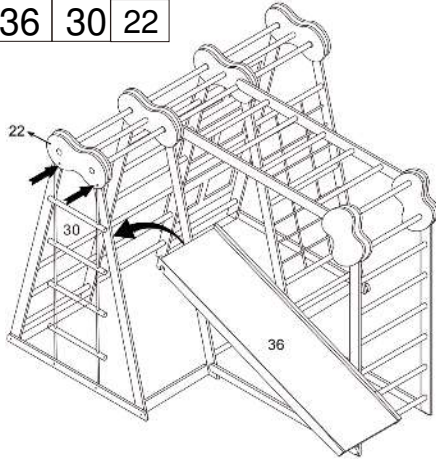

Schritt 25

Führen Sie die 34er durch die 33er, lassen Sie dann die 38er durch die 34er laufen. Wickeln Sie schließlich die 34er in einer sicheren Position und wickeln Sie sie fest. Verbinden Sie 31 und 32, stecken Sie dann 32 in die beiden verbleibenden Löcher in 8 und binden Sie sie ab.

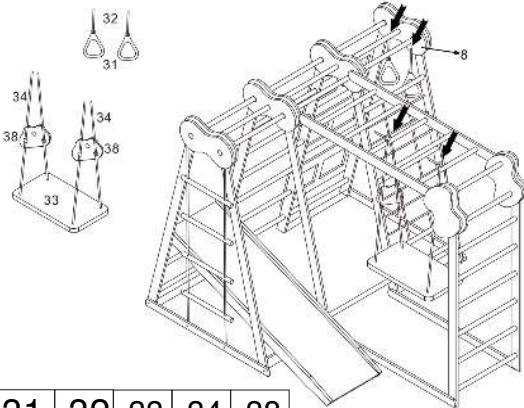

31 | 32 | 33 | 34 | 38

ANLEITUNG ZUM FALTEN

Schritt 1

Folding function

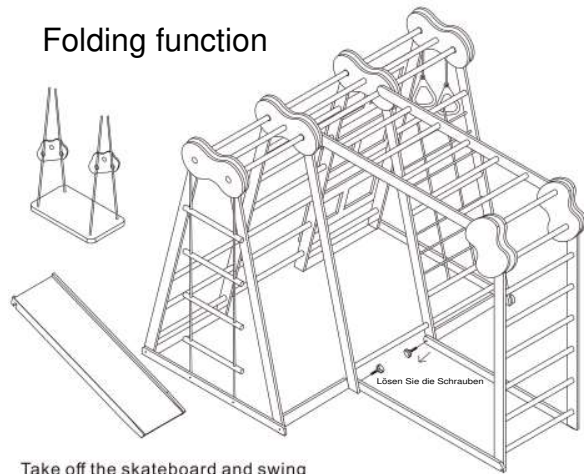

Take off the skateboard and swing

Das Skateboard abnehmen und schwingen

Schritt 2

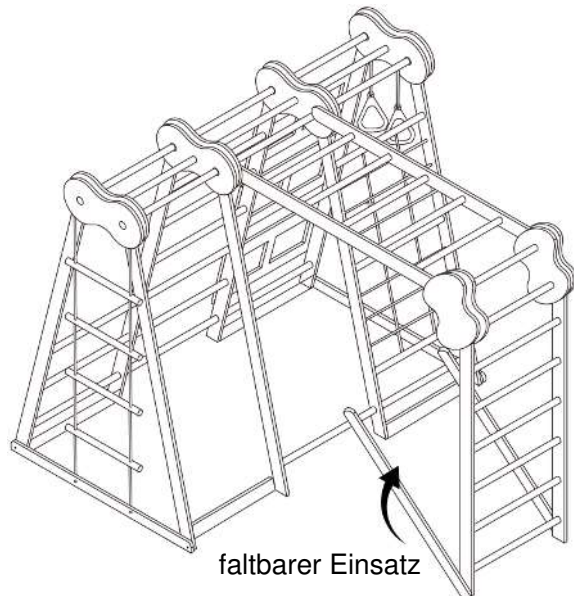

Schritt 3

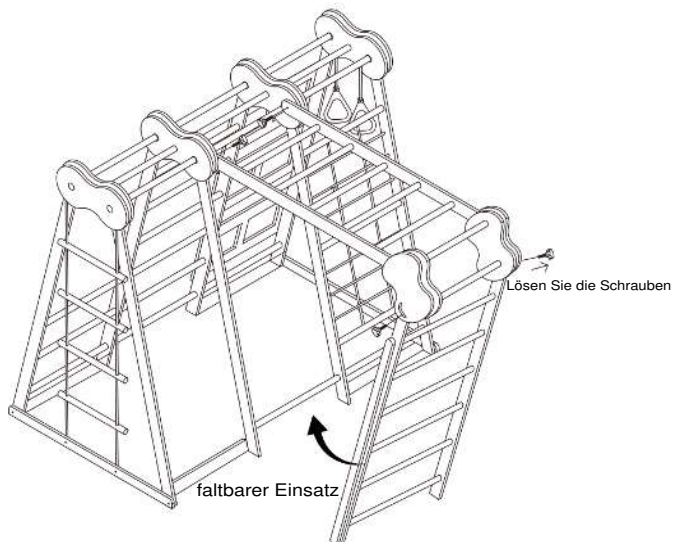

INSTALLATION

Schritt 4

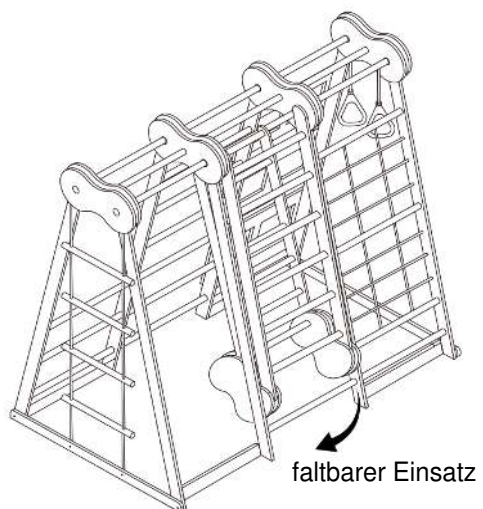

Schritt 7

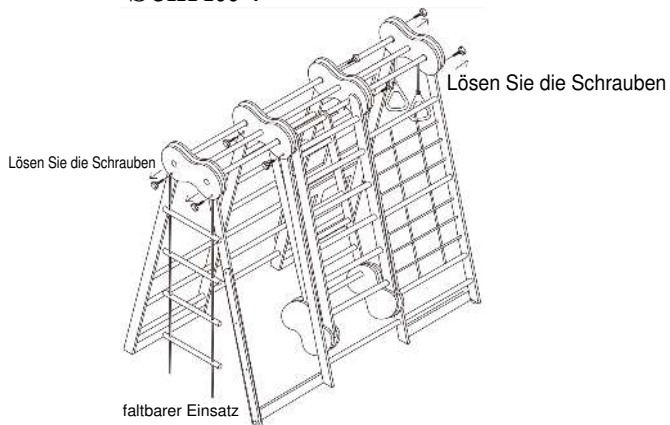

Schritt 8

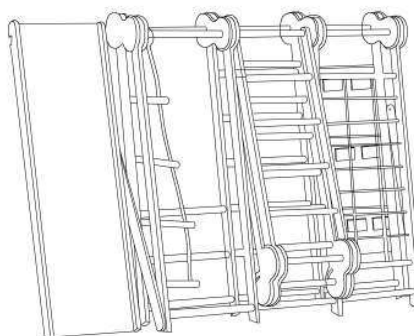

Schritt 5

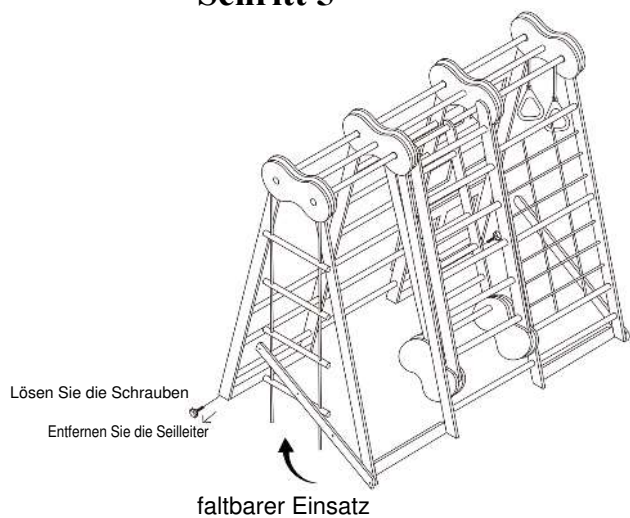

Schritt 6



INSTALLATION

ALLGEMEINE SICHERHEITSHINWEISE

1. Dieses Produkt ist nur für den Innen-, Außen-, Heim- und Hausgebrauch bestimmt. es ist nicht für den gewerblichen oder medizinischen Gebrauch geeignet.
2. Die Montage des Produkts muss sorgfältig und von einem mündigen Erwachsenen durchgeführt werden. im Zweifelsfall fragen Sie eine technisch qualifizierte Person.
3. Verwenden Sie das Produkt nicht, wenn es beschädigt oder defekt ist. Wenn es beschädigt oder defekt ist, wenden Sie sich bitte an einen qualifizierten Techniker.
4. Überprüfen Sie das Produkt vor jedem Gebrauch. Defekte Teile müssen sofort ausgetauscht werden, da sie die Funktion und die Sicherheit des Produkts beeinträchtigen können.
5. Verwenden Sie das Produkt nur auf ebenen und rutschfesten Oberflächen. Halten Sie aus Sicherheitsgründen ausreichend Platz in der Umgebung ein.
6. Beachten Sie, dass bei der Verwendung von Werkzeugen oder bei technischen Arbeiten immer die Gefahr von Verletzungen besteht. Montieren Sie das Produkt mit Sorgfalt.
7. Nachdem Sie das Produkt gemäß der Bedienungsanleitung montiert haben, vergewissern Sie sich, dass alle Schrauben, Bolzen und Muttern korrekt angebracht und angezogen sind und dass alle Verbindungen sicher sind.
8. Nehmen Sie keine Änderungen am Produkt vor. Verwenden Sie nur Original-Ersatzteile. Reparaturen sollten nur von qualifizierten

Technikern durchgeführt werden – unsachgemäße Reparaturen können zu Gefahren für den Benutzer führen.

WICHTIG

Die Bedienungsanleitung enthält Sicherheits-, Montage-, Gebrauchs- und Wartungsanweisungen. Das Produkt muss von einem Erwachsenen montiert werden, der diese Anweisungen gelesen und verstanden hat. Bewahren Sie die Verpackung außerhalb der Reichweite von Kindern auf und entsorgen Sie die gesamte Verpackung vor dem Gebrauch.

INSTALLATION

BEDIENUNGSANLEITUNGEN

1. Lassen Sie das Produkt stets von einem Erwachsenen beaufsichtigen.
 2. Das zerlegte Produkt enthält kleine Teile, die für Kinder unter 3 Jahren eine Erstickungsgefahr darstellen
 3. Ziehen Sie Kinder angemessen an und tragen Sie gut sitzende Schuhe, die die Füße vollständig schützen.
 4. Die Kinder anweisen:
 - in der Mitte der Schaukel zu sitzen und ihr ganzes Gewicht auf die Sitze zu legen
 - das Schaukeln auf leeren Sitzen zu vermeiden,
 - mit den Füßen zuerst zu rutschen; immer nur ein Kind auf einmal,
 - vor dem Spielen auf den Geräten Gegenstände zu entfernen, die eine Gefahr darstellen, wenn sie sich verheddern und verfangen.
 - nicht in der Nähe von, vor, hinter oder zwischen sich bewegenden Gegenständen zu laufen,
 - nicht aus dem Gerät auszusteigen, während es in Bewegung ist.
- Erlauben Sie Kindern niemals, das Gerät auf eine andere als die vorgesehene Weise zu benutzen. Nicht im Stehen schwingen oder mit dem Kopf nach unten rutschen.

Multi-function Climbing frame

USER MANUAL



SKU: WF1973478 (N621P197347+ N621P197348)

Test Request: EN71

ITEM NO: WF1973478A

READ AND SAVE THIS INSTRUCTION FOR FUTURE USE

SAFETY & WARNINGS

ADULT ASSEMBLY REQUIRED.

- Keep these instructions for future reference.
- This product is intended for indoor, family, domestic use only.
- Place this product on level ground and at least 6.6' away from a fence, building, overhead branches, laundry lines or electrical wires. This product should be placed away from furniture that could cause injury if a fall occurs.
- Ensure the installation area is ventilated.
- Do not use the product if it is damaged or defective. If it is damaged or defective, please contact a qualified technician.
- Check that all parts are assembled well and are stable before use. Defective parts must be changed immediately as they can impair the function and the safety of the product.
- When temperatures fall below freezing, (0°C/32°F), outdoor use of this product is not recommended. In extreme cold, plastic materials lose resilience and may become brittle and crack with impact. Store product in a warmer, protected place.
- Keep away from fire or any source of ignition.
- Packing materials are not toys, keep them away from children.
- Instruct children on proper use of this product: only after properly assembled and installed, and not in a manner other than intended.
- Dress children appropriately: do not allow children to wear loose-fitting clothing including ponchos, scarves and garments with drawstrings. Well-fitting shoes must be worn at all times.
- Avoid placing equipment in direct sunlight as hot surfaces could cause serious burns.
- Provide adult supervision at all times.
- It is very important to operate according to the following requirements periodically or at the beginning of each season during use.
 - Check all bolts and nuts for sharp edges and replace them if necessary.
 - Check that all screws are tightened, and if necessary, tighten them.
 - please wipe with a dry cloth regularly.

Note:

- 1.Outdoor use is prohibited!
- 2.No swallow!
- 3.Children must be supervised by an adult!











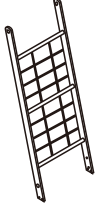

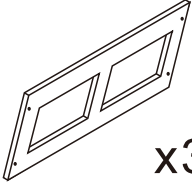

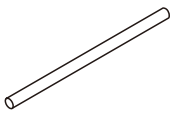
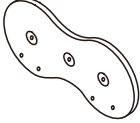
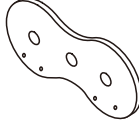
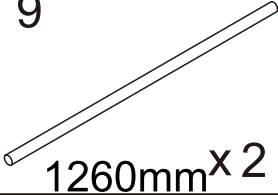
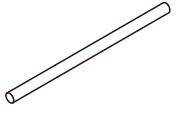
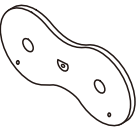
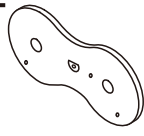
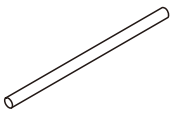
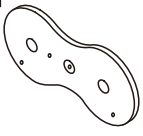
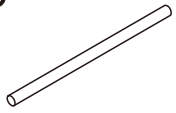

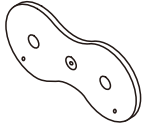
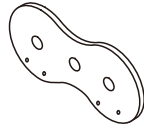

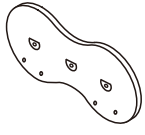
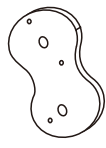

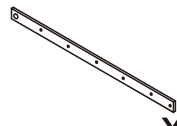
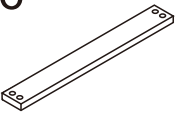
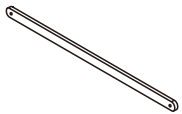
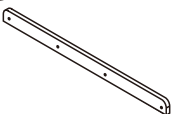
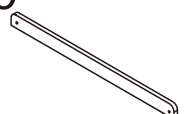
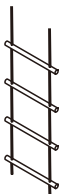

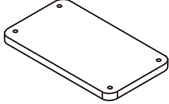

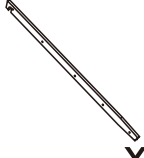
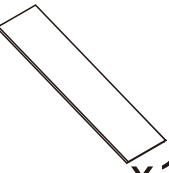
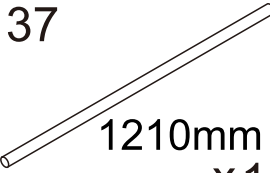
PLEASE DO NOT RETURN TO STORE



**Please do not return this product to the retailer!!
We are able to assist you in ANY way.**

If you find that you have any trouble with assembly or missing or damaged parts, please contact the seller.

PART LIST

1  x1	2  x1	3  x1	4  x3	5  x2
6  307mm x13	7  x1	8  x1	9  1260mm x2	10  406mm x2
11  x1	12  x1	13  798mm x3	14  x1	15  387mm x3
16  x1	17  x1	18  x1	19  x1	20  x1
21  x1	22  x1	23  x2	24  x2	25  x2
26  x4	27  x2	28  x1	29  x1	30  x1
31  x2	32  x2	33  x1	34  x2	35  x2
36  x1	37  1210mm x1	38  x2	39  357mm x1	
A  M5x30mm x28	B  M7x50MM x56	C  M6x50MM x4	D  M7x70MM x4	E  M6x50mm x10
F  M6x35MM x8	G  M6x35MM x2	H  x1		

ASSEMBLY

Step1

Connect 1 7 ,3,4 together with A.

17	3	4
A		

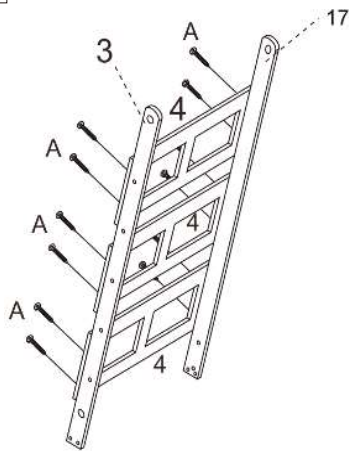

Step2

Place 1 and 17 between 7 and 8 and secure with E.

7	8	1	17
E			

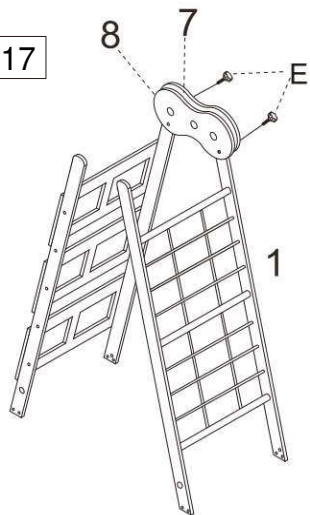

Step3

Insert 10 into the holes in the middle of 7 and 8 and secure with B. Place 11 between 3 and 1 and fix 10 and 11 with B.

7	8	10
11	3	1
B		

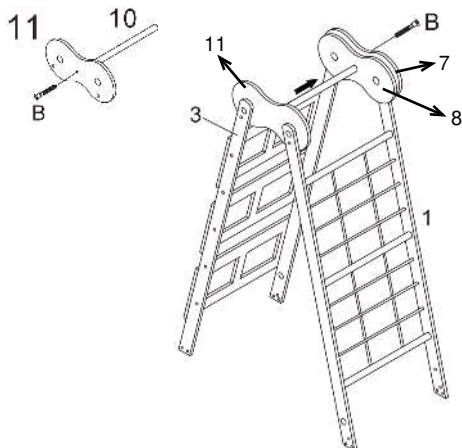

Step4

Connect 3 and 11, 1 and 11 with 9.
Fix with B screws

3	1	11
9	B	

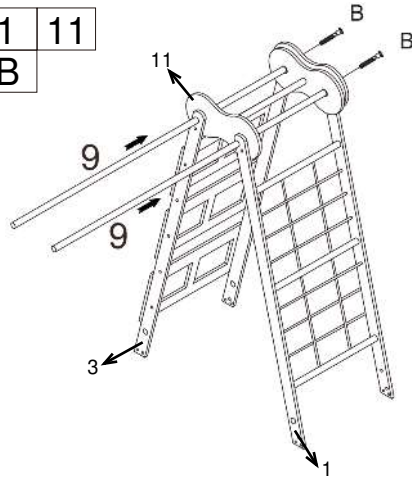

Step5

Secure 12 to both 9. and insert 39 into the hole in the center of 12, securing it with B.

12	9	39
B		

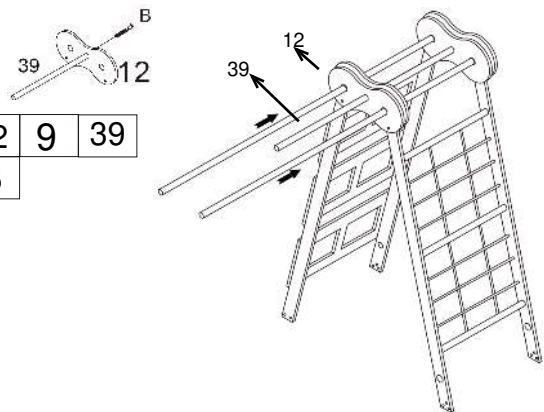

Step6

Fix 3 , 1 and 11,12 with E.
Cross 1 7 and 3 with 37 and fix with B.

3	1	11
12	17	37
E	B	

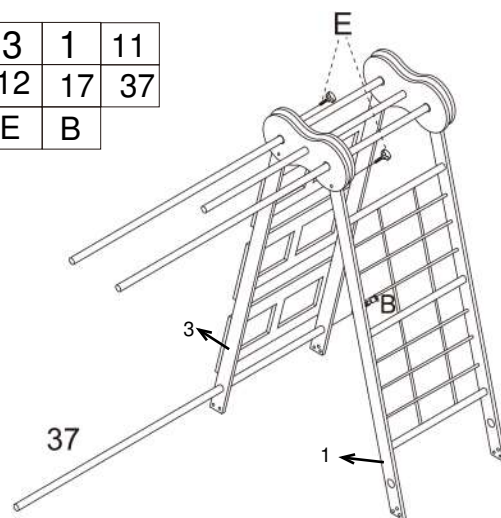

ASSEMBLY

Step7

Fasten two 13s to 3 with B.

13	3	B
----	---	---

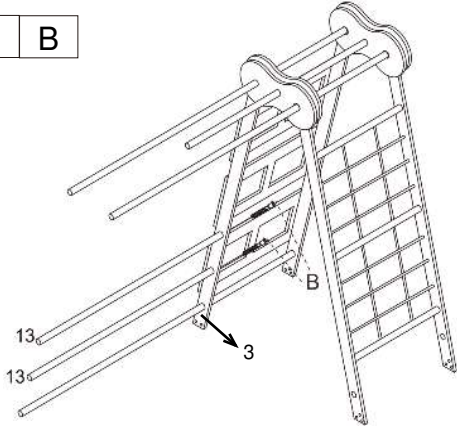

Step10

Let the two 5s pass through 9. Let 13 pass through 1 and secure the ends of 1 and 13 with B.

5	9	13
1	B	

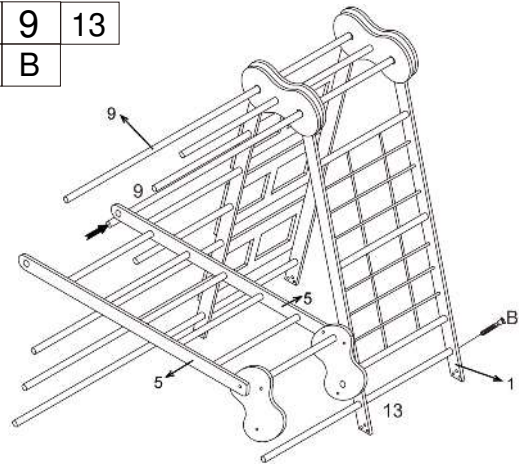

Step8

Fasten three 15s to 3 with B.

15	3	B
----	---	---

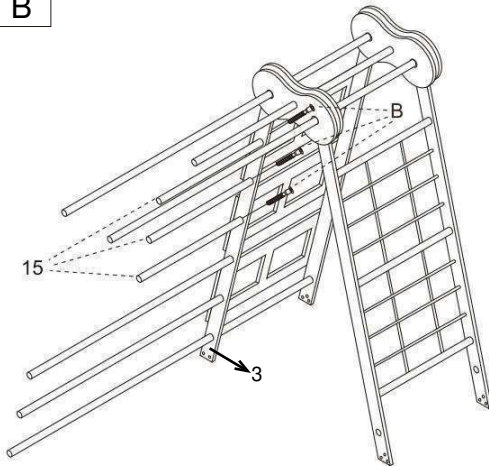

Step11

Let 14 pass through the two 9's and against the side of the 39's, securing the 39's and 14's with B. Then pass 16 and 2 through the 9's, Pass the 13's through the 16's, securing the 15's and 16's together with B. Fix 13 and 2 with B. Secure the 5's and 12's and 14's with F.

14	9	39	13
16	2	15	5
12	B	F	

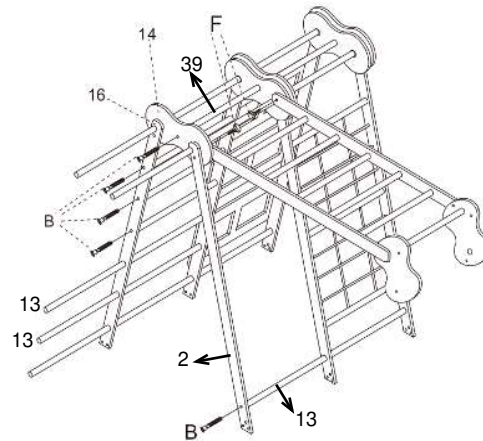

Step9

Insert the ends of one 6 into the 23 center slot and place it between the two 5s (Do not screw in!). Insert the 6 between the two 5s as shown.

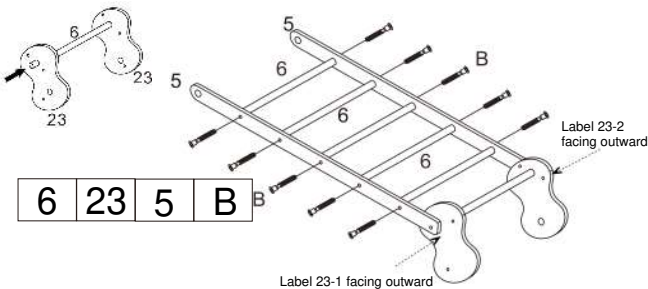

6	23	5	B
---	----	---	---

Step12

Fix 10 and 18 with B. Let 18 pass through both 9s.

10	18
9	B

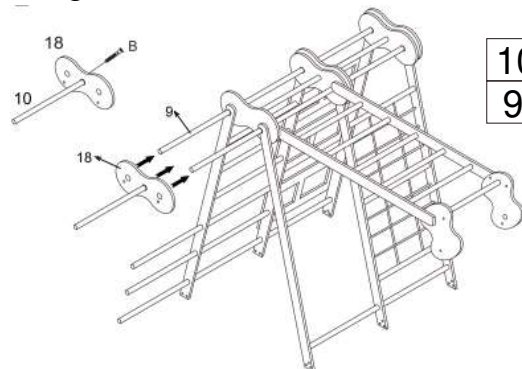

ASSEMBLY

Step13

Fix 18 and 16 and 2 with E.

18	16
2	E

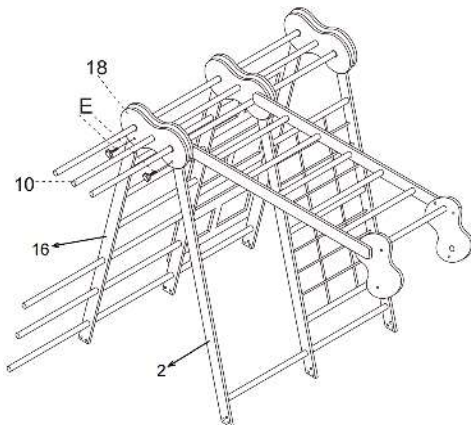

Step14

Pass 19 through the two 9's and 10's. Let 20 and 21 pass through 9. Fix 21 and 13, 37 with B.

19	9	10	20
21	13	37	B

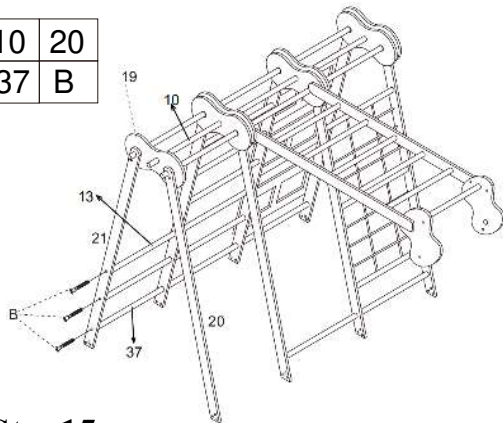

Step15

Pass 22 through the two 9s and 10. Secure 20, 21, 22 together with E. Use B to fasten 22 to 9 and 10.

22	9	10	20
21	E		

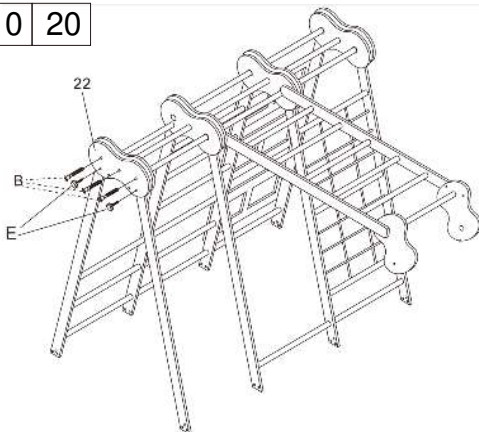

Step16

Insert the other 6 between the two 23s.

23	6
----	---

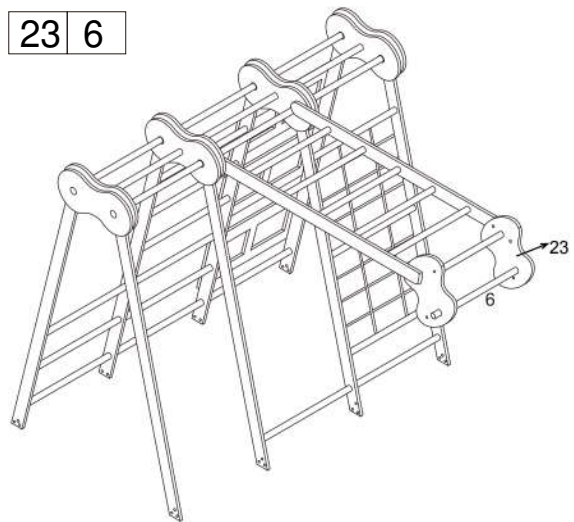

Step17

Fixed with B 6s and 25s.

6	25	B
---	----	---

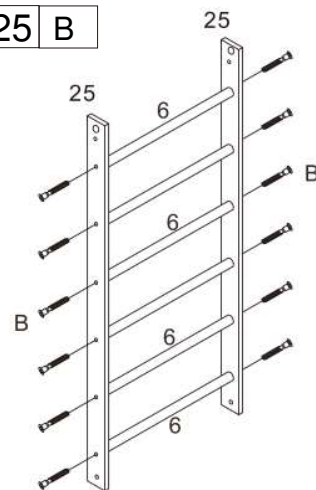

Step18

Let the 25s rest on the outside of the 23s, then put the 24s on the outside of the 25s. Fix 6 and 24 with D. Fix 24 and 5 with C.

25	23	24	6	5
C	D			

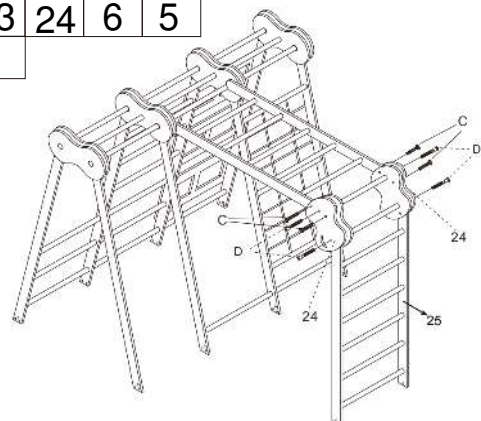

ASSEMBLY

Step19

Insert E into 24.

E	24
---	----

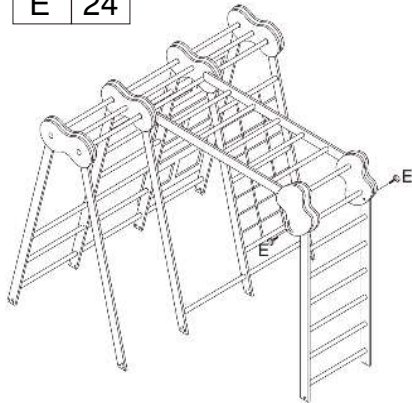

Step20

Fix 26 and 1, 3, 16, 17, 20, 21 with A.

26	1	2	3
16	17	20	21
A			

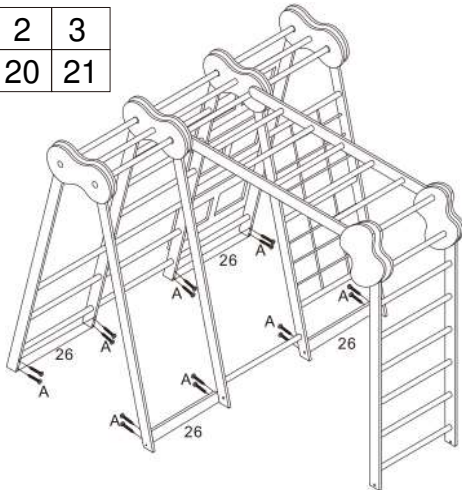

Step21

Fix 28 and 21,2 0 with F. Fix 29 and 1, 17 with F.

28	20	21	29
1	17	F	

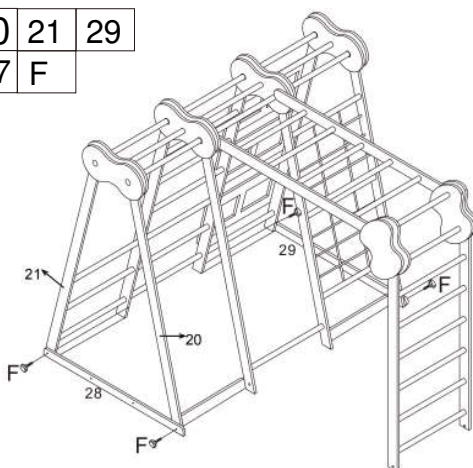

Step22

Fix 25s and 27s with G. Fix 27s and 1,2 with F.

25	27	1
2	F	G

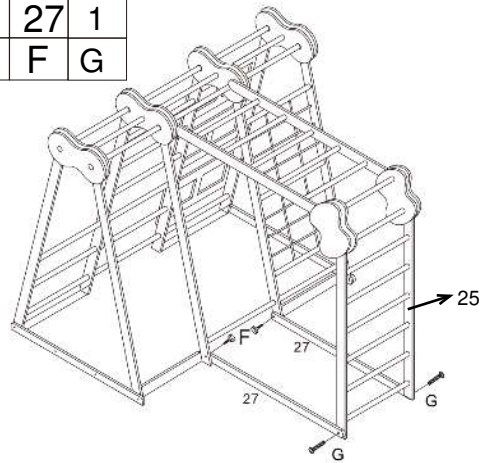

Step23

Fix 35 and 36 with B.

35	36	B
----	----	---

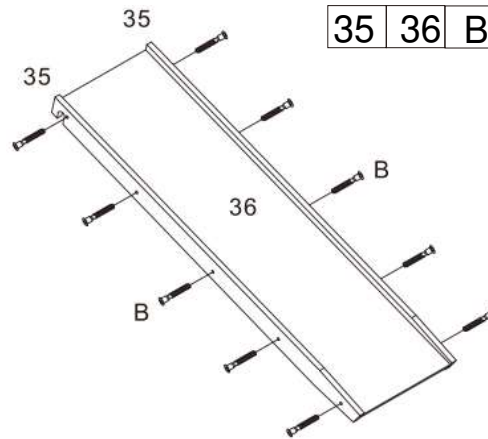

Step24

Place 36 on the round bar and thread 30 through the two remaining holes in 22 and fasten.

36	30	22
----	----	----

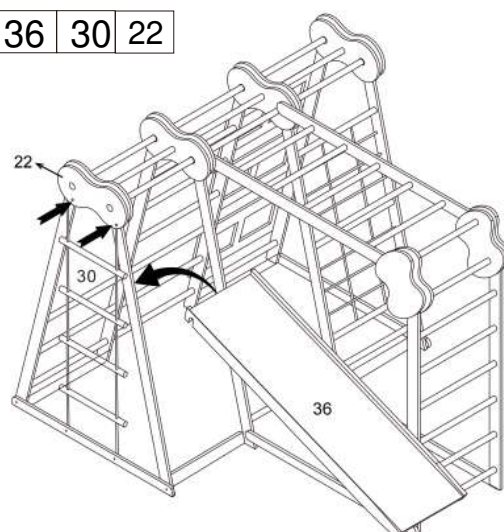

ASSEMBLY

Step25

Pass the 34s through the 33s then let the 38s pass through the 34s. finally wrap the 34s in a safe position and wrap tightly. Connect 31 and 32, then insert 32 into the two remaining holes in 8 and tie off.

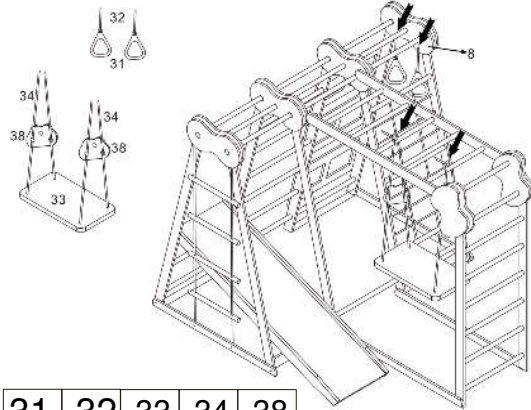

HOW TO FOLDING

Step1

Folding function

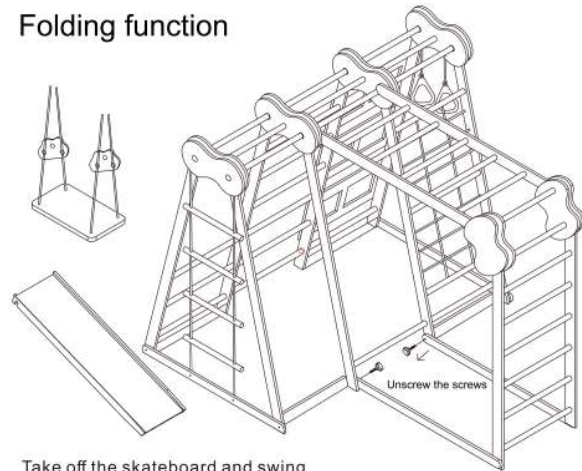

Take off the skateboard and swing

Step2

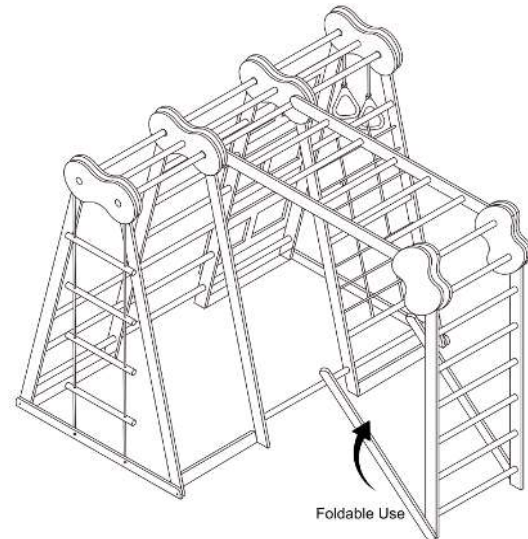

Step3

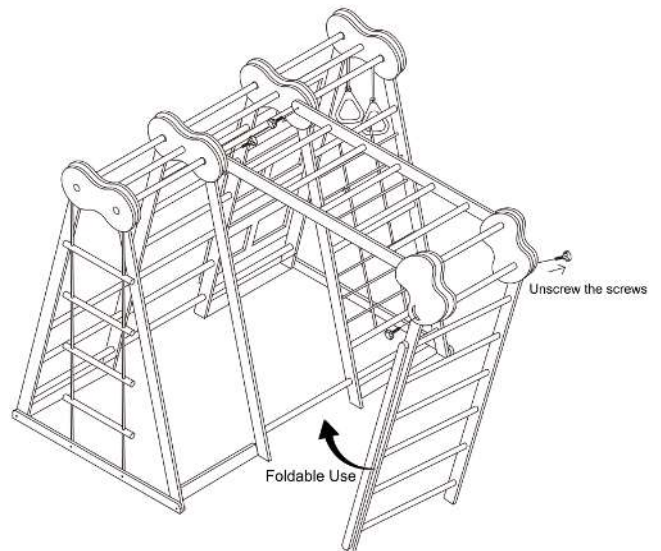

ASSEMBLY

Step4

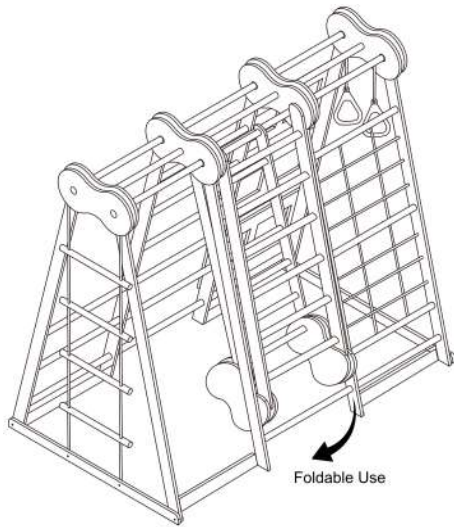

Step7

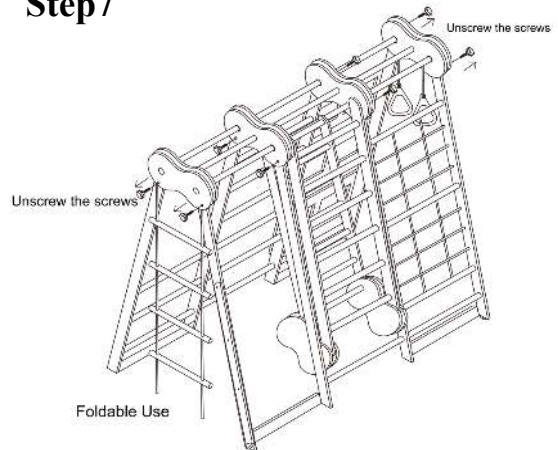

Step5



Step8

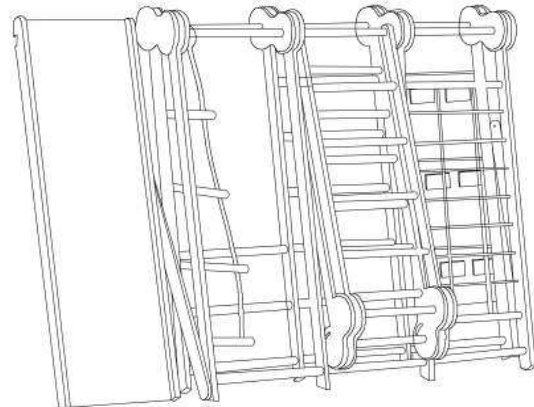

Step6



ASSEMBLY

GENERAL SAFETY INSTRUCTIONS

1. This product is intended for indoor, home, domestic use only. It is not suitable for commercial or medical use.
2. The assembly of the product must be done carefully and by an able-bodied adult. If in any doubt, ask a technically qualified person.
3. Do not use the product if it is damaged or defective. If it is damaged or defective, please contact a qualified technician.
4. Check the product before each use. Defective parts must be changed immediately as they can impair the function and the safety of the product.
5. Use the product only on even and non-slip surfaces. Keep sufficient space around for safety.
6. Beware that when using tools or doing technical work, there is always a risk of injuries. Assemble the product with care.
7. After installing the product according to the instruction manual, ensure all screws, bolts and nuts are correctly installed and tightened and that all joints are secure.
8. Do not make alterations to the product. Only use original spare parts. Only qualified technicians should carry out repairs - improper repairs can lead to danger for the user. Use this product only as described in this manual.

IMPORTANT

The owner's manual contains safety, assembly, use and maintenance instructions. The product must be assembled by an adult who has read and understood these instructions. Keep the packaging away from children and dispose of all packaging before use.

OPERATION INSTRUCTIONS

1. Provide adult supervision at all times.
 2. The disassembled product contains small parts which pose a choking hazard to children under 3
 3. Dress children appropriately, including wearing well-fitting shoes that fully protect feet.
 4. Instruct children:
 - to sit in the center of the swings with their full weight on the seats
 - to avoid swinging empty seats,
 - to slide feet first; one child down slide at a time,
 - to remove articles, before playing on equipment, that create hazards when they get tangled and caught.
 - not to walk close to, in front of, behind, or between moving items,
 - not to get off equipment while it is in motion.
- Never allow children to use the equipment in a manner other than intended. Do not swing while standing or slide down head first.

Cadre d'escalade multifonctionnel pour enfants

MANUEL DE L'UTILISATEUR

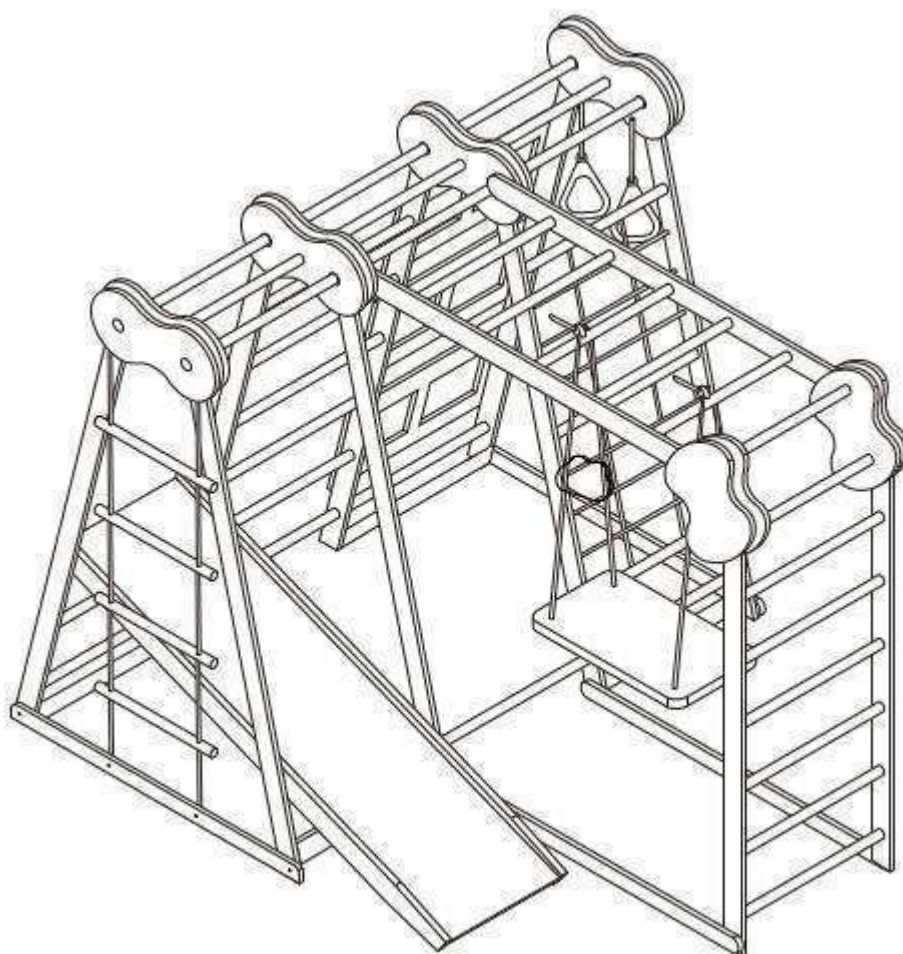

SKU: WF1973478 (N621P197347+ N621P197348)

DEMANDE DESSAI: EN71

NUMERO D'ARTICLE: WF1973478A

LIRE ET CONSERVER CETTE INSTRUCTION POUR UNE UTILISATION FUTURE

SÉCURITÉ & AVERTISSEMENTS

ASSEMBLAGE PAR UN ADULTE REQUIS.

- Conservez ces instructions pour référence future.
- Ce produit est destiné à un usage intérieur, familial et domestique uniquement.
- Placez le produit sur une surface plane à au moins 200 cm de la clôture, d'un bâtiment, de branches aériennes ou de fils électriques, d'une clôture, d'un bâtiment, d'une branche aérienne, d'une corde à linge ou d'un fil électrique. Ce produit doit être placé loin des meubles qui pourraient causer des blessures en cas de chute.
- Assurez-vous que la zone d'installation est ventilée.
- N'utilisez pas le produit s'il est endommagé ou défectueux. S'il est endommagé ou défectueux, veuillez contacter un technicien qualifié.
- Vérifiez que toutes les pièces sont bien assemblées et qu'elles sont stables avant de les utiliser. Les pièces défectueuses doivent être remplacées immédiatement car elles peuvent nuire au fonctionnement et à la sécurité du produit.
- Lorsque les températures descendent en dessous du point de congélation (0°C/32°F), l'utilisation de ce produit à l'extérieur n'est pas recommandée. Par grand froid, les matières plastiques perdent de leur élasticité et peuvent devenir cassantes et se fissurer sous l'effet d'un choc. Stocker le produit dans un endroit plus chaud et protégé.
- Tenir à l'écart du feu ou de toute source d'ignition.
- Les matériaux d'emballage ne sont pas des jouets, gardez-les hors de portée des enfants.
- Apprenez aux enfants à utiliser correctement ce produit : uniquement après l'avoir correctement assemblé et installé, et pas d'une manière autre que celle prévue et installé correctement, et pas d'une manière autre que celle prévue.
- Habillez les enfants de manière appropriée : ne permettez pas aux enfants de porter des vêtements amples, y compris des ponchos, des écharpes et des vêtements avec des cordons. Ne pas laisser les enfants porter des vêtements amples, y compris des ponchos, des écharpes et des vêtements avec des cordons de serrage. Des chaussures bien adaptées doivent être portées en permanence.
- Évitez de placer l'appareil en plein soleil, car les surfaces chaudes peuvent provoquer de graves brûlures.
- Il est très important de respecter les exigences suivantes périodiquement ou au début de chaque saison d'utilisation.

Vérifiez que tous les boulons et écrous ne présentent pas d'arêtes vives et remplacez-les si nécessaire.

Vérifiez que toutes les vis sont bien serrées et, si nécessaire, resserrez-les.
essuyer régulièrement avec un chiffon sec.

Remarque :

1. l'utilisation à l'extérieur est interdite !
2. Il est interdit d'avaler le produit !
3. les enfants doivent être surveillés par un adulte !

MERCI DE NE PAS RETOURNER EN MAGASIN











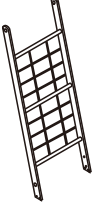

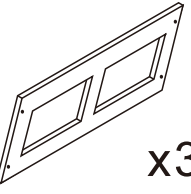

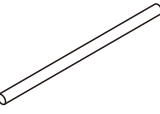
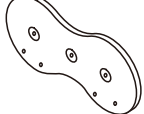
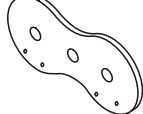

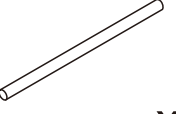
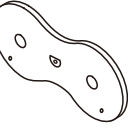
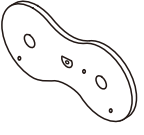
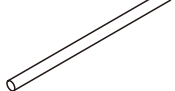
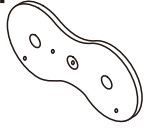
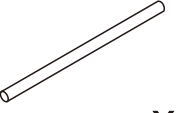

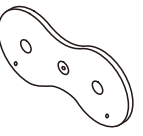
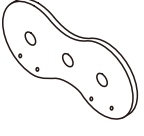

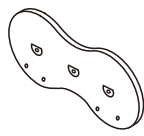

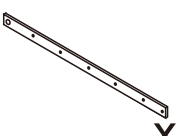
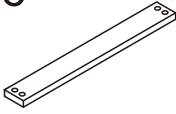
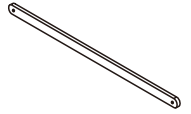
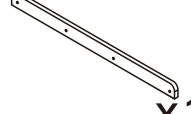
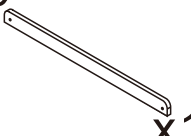
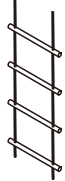

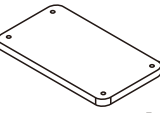

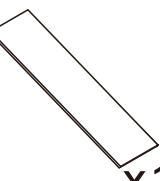
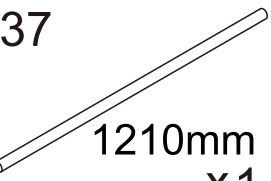
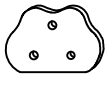
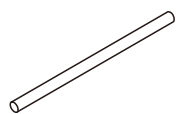
Veillez ne pas retourner ce produit au revendeur !!

Nous sommes en mesure de vous aider de TOUTE manière.

Si vous trouvez que vous avez des problèmes avec l'assemblage ou pièces manquantes ou endommagées, veuillez contacter le vendeur.

LISTE DES PIÈCES

1  x1	2  x1	3  x1	4  x3	5  x2
6  307mm x13	7  x1	8  x1	9  1260mm x 2	10  406mm x 2
11  x1	12  x1	13  798mm x3	14  x1	15  387mm x3
16  x1	17  x1	18  x1	19  x1	20  x1
21  x1	22  x1	23  x2	24  x2	25  x2
26  x4	27  x2	28  x1	29  x1	30  x1
31  x2	32  x2	33  x1	34  x2	35  x2
36  x1	37  1210mm x1	38  x2	39  357mm x 1	
A  M5x30mm x28	B  M7x50MM x 56	C  M6 x 50MM x4	D  M7x70MM x4	E  M6x50mm x10
F  M6x35MM x8	G  M6 x 35MM x2	H  x1		

ASSEMBLER

Étape1

Relier 17,3,4 avec A.

17	3	4
A		

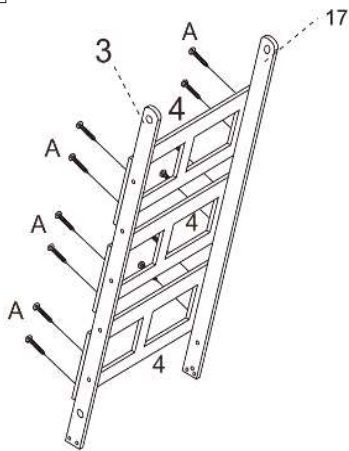

Étape4

Relier 3 et 11, 1 et 11 avec 9.
Fixation avec B - vis

3	1	11
9	B	

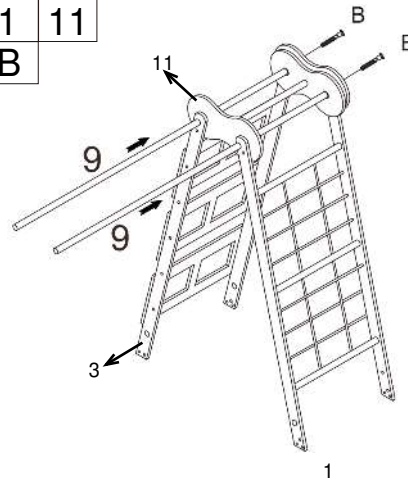

Étape2

Placer 1 et 17 entre 7 et 8 et fixer avec E.

7	8	1	17
E			

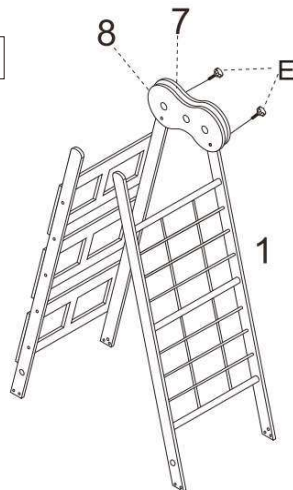

Étape5

Fixez 12 aux deux 9. et insérez 39 dans le trou au centre de 12, en le fixant avec B.

12	9	39
B		

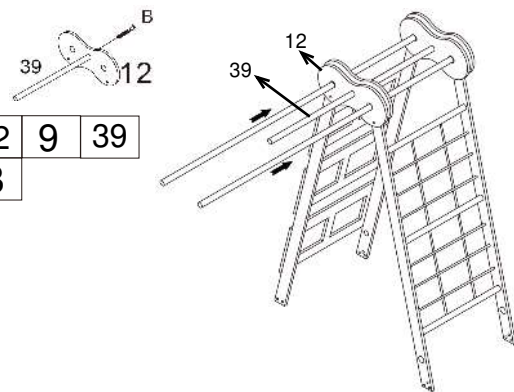

Étape3

Insérer 10 dans les trous au milieu de 7 et 8 et fixer avec B. Placer 11 entre 3 et 1 et fixer 10 et 11 avec B.

7	8	10
11	3	1
B		

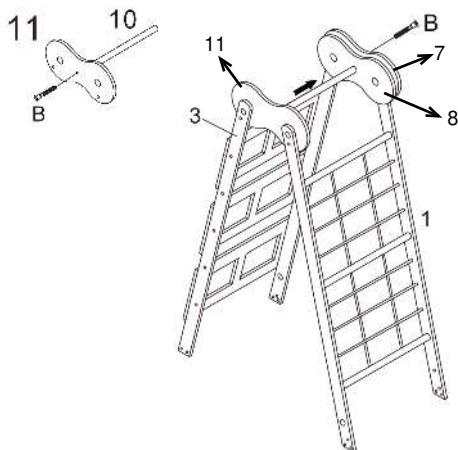

Étape6

Fixer 11 et 12 à 3 et 1 avec E - vis

3	1	11
12	17	37
E	B	

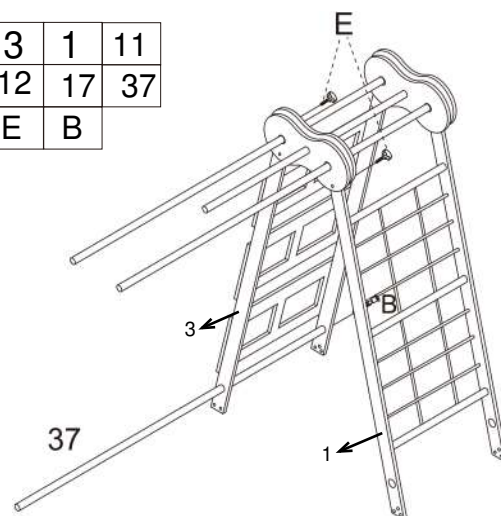

ASSEMBLER

Étape7

Fixer deux 13 à 3 avec B.

13	3	B
----	---	---

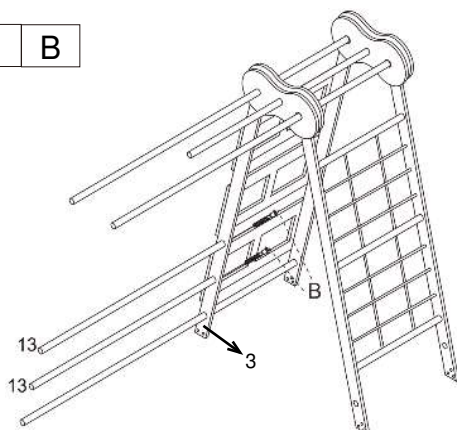

Étape8

Fixez trois 15 à 3 avec B.

15	3	B
----	---	---

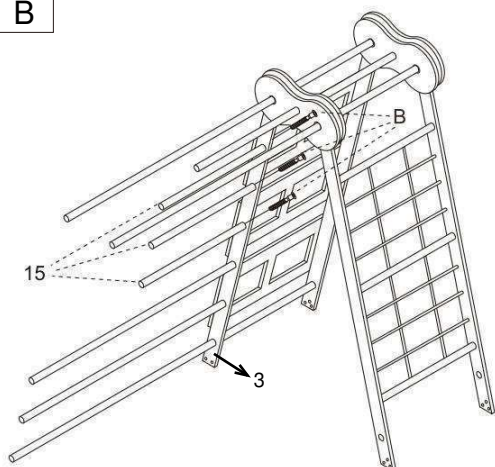

Étape9

Insérer les extrémités d'un 6 dans la fente centrale du 23 et le placer entre les deux 5 (ne pas visser !). Insérer le 6 entre les deux 5 comme indiqué.

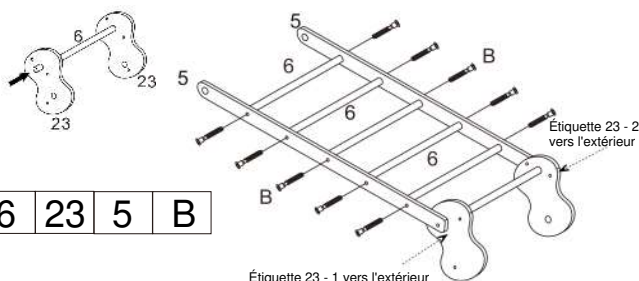

6	23	5	B
---	----	---	---

Étape10

Faites passer les deux 5 par le 9. Laissez passer le 13 par le 1 et fixez les extrémités du 1 et du 13 avec B.

5	9	13
1	B	

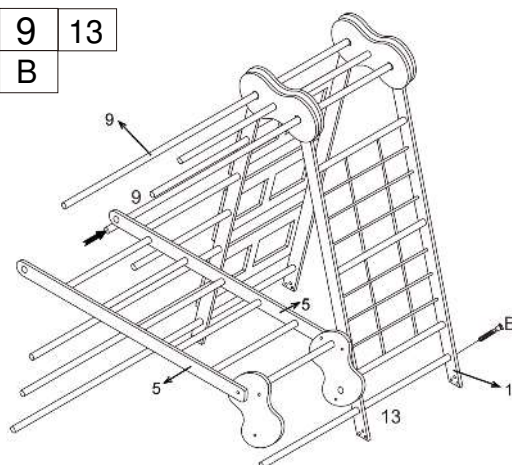

Étape11

Laissez passer 14 à travers les deux 9 et contre le côté des 39, en fixant les 3 9 et les 14 avec B. Ensuite, faites passer 16 et 2 à travers les 9, faites passer les 13 à travers les 16, en fixant les 15 et les 16 ensemble avec B. Fixez 13 et 2 avec B. en fixant les 5, les 12 et les 14 avec F.

14	9	39	13
16	2	15	5
12	B	F	

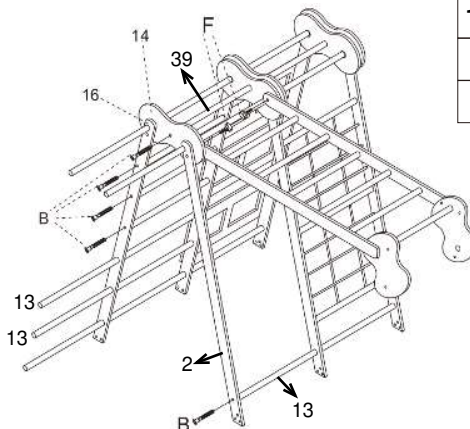

Étape12

Fixez 10 et 18 avec B. Laissez 18 passer par les deux 9.

10	18
9	B

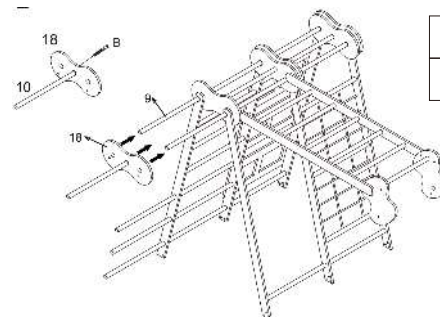

ASSEMBLER

Étape13

Fixer 18 et 16 et 2 avec E.

18	16
2	E

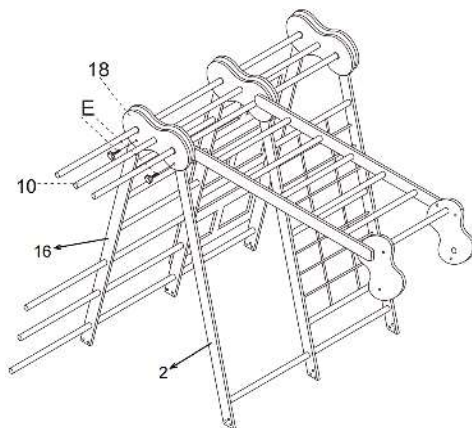

Étape16

Insérez l'autre 6 entre les deux 23.

23	6
----	---

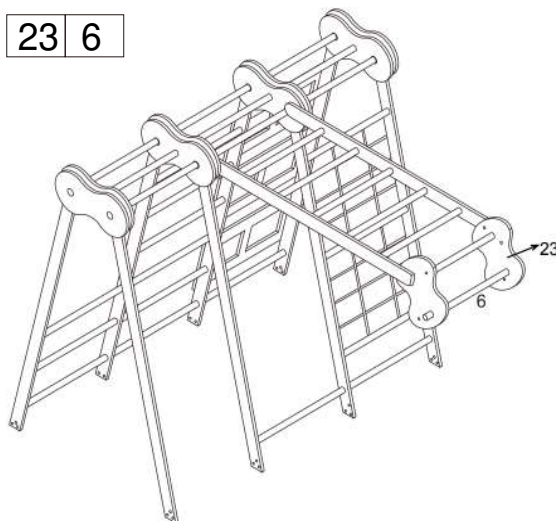

Étape14

Faites passer 19 par les deux 9 et 10.
Faites passer 20 et 21 par 9. Fixez 21 et 13, 37 avec B.

19	9	10	20
21	13	37	B

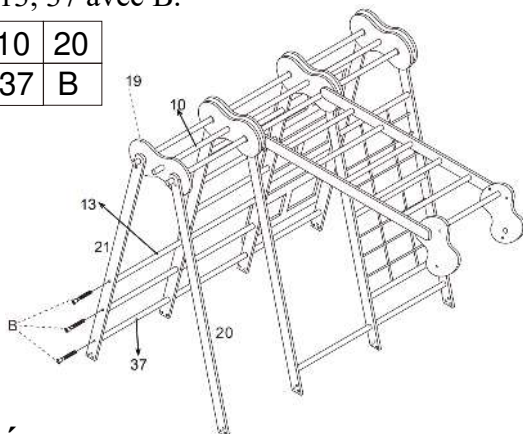

Étape17

Fixé avec B 6s et 25s.

6	25	B
---	----	---

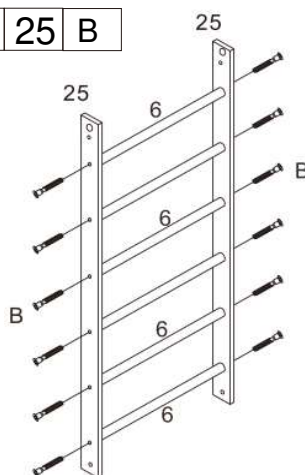

Étape15

Faites passer 22 à travers les deux 9 et 10.
Fixez 20, 21, 22 ensemble avec E.
Utilisez B pour fixer 22 à 9 et 10.

22	9	10	20
21	E		

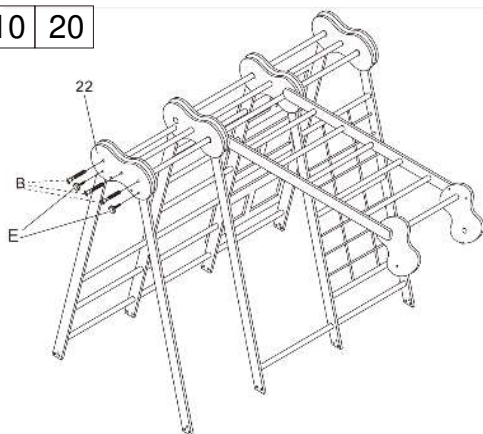

Étape18

Laissez les 25 reposer à l'extérieur des 23,
puis placez les 24 à l'extérieur des 25.
Fixez 6 et 24 avec D. Fixez 24 et 5 avec C.

25	23	24	6	5
C	D			

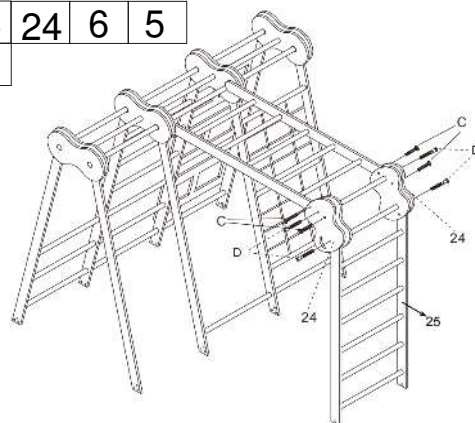

ASSEMBLER

Étape19

Insérer E dans 24.

E	24
---	----



Étape20

Fixer 26 et 1, 3, 16, 17, 20, 21 avec A.

26	1	2	3
16	17	20	21
A			

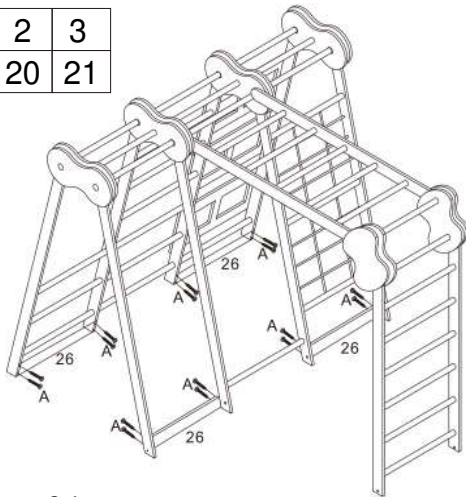

Étape21

Fixer 28 et 21, 20 avec F. Fixer 29 et 1, 17 avec F.

28	20	21	29
1	17	F	

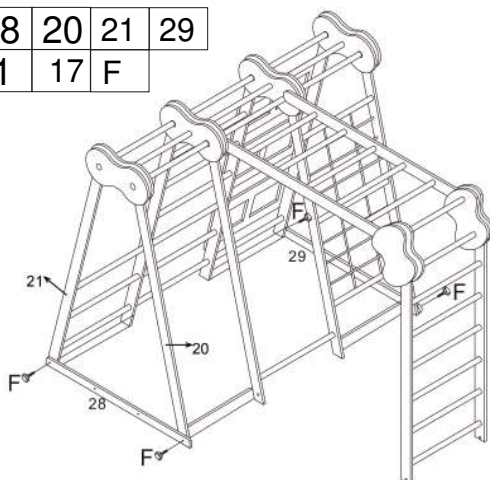

Étape22

Fixer les 25 et 27 avec G. Fixer les 27 et 1, 2 avec F.

25	27	1
2	F	G

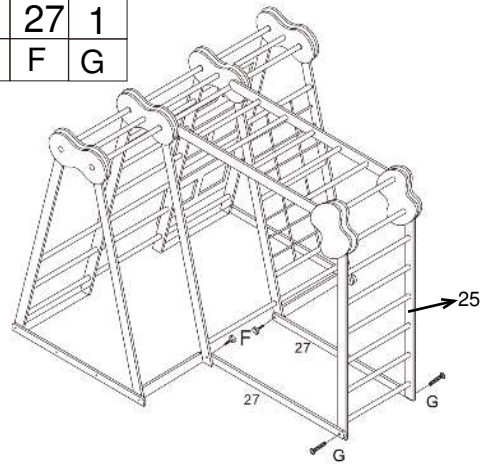

Étape23

Fixer 35 et 36 avec B.

35	36	B
----	----	---

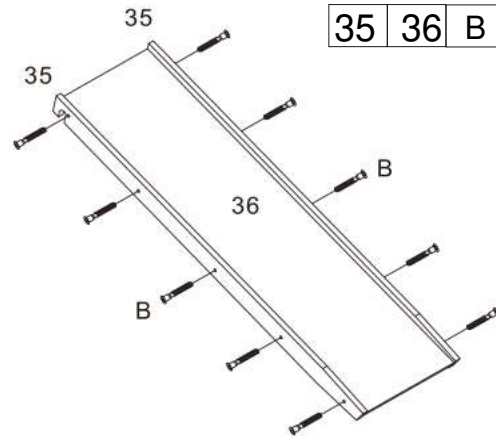

Étape24

Placer 36 sur la barre ronde et passer 30 dans les deux trous restants de 22 et fixer.

36	30	22
----	----	----

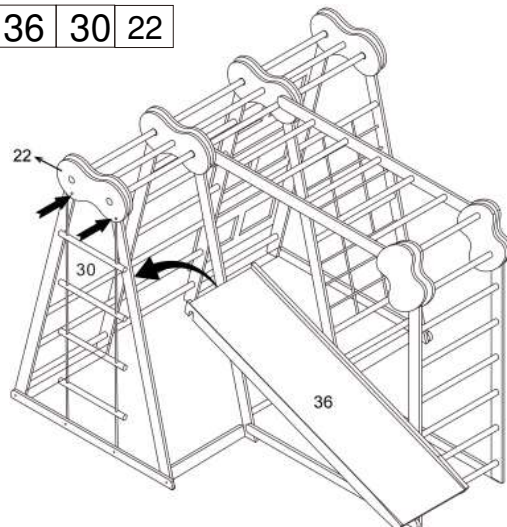

ASSEMBLER

Étape25

Faites passer les 34 dans les 33, puis laissez les 38 passer dans les 34. Enfin, enroulez les 34 dans une position sûre et serrez-les bien. Reliez 31 et 32, puis insérez 32 dans les deux trous restants de 8 et attachez.

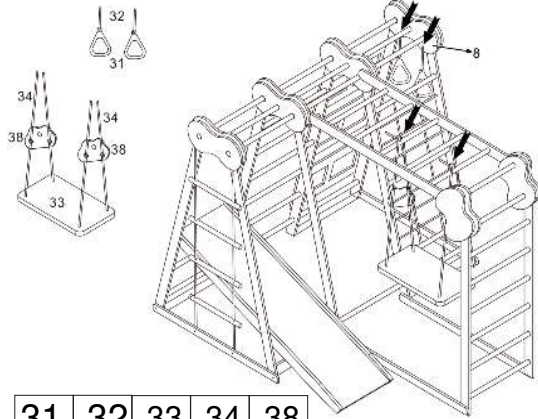

31	32	33	34	38
----	----	----	----	----

COMMENT PLIER

Étape1

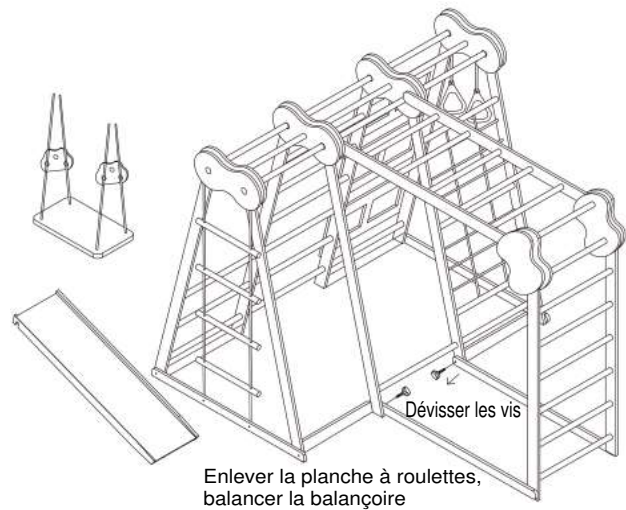

Étape2

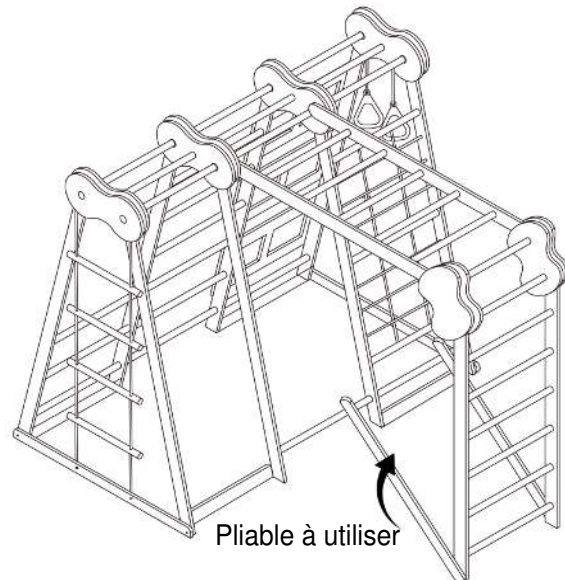

Étape3

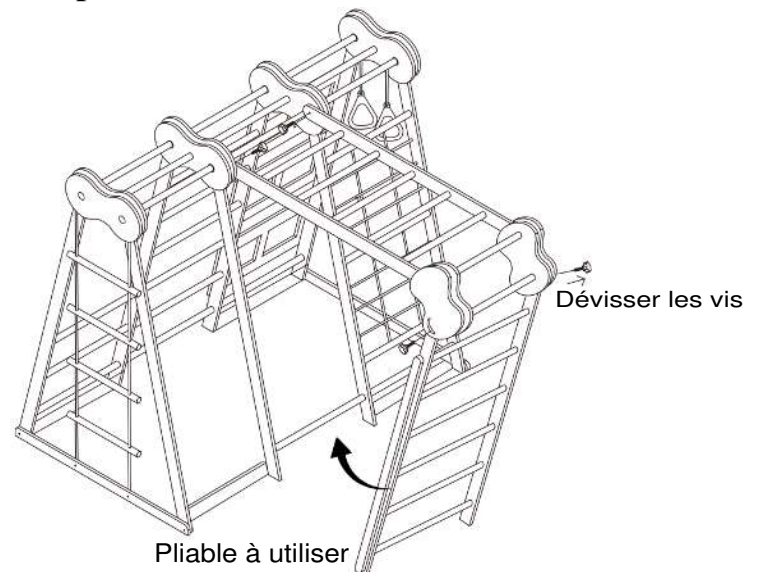

ASSEMBLER

Étape4

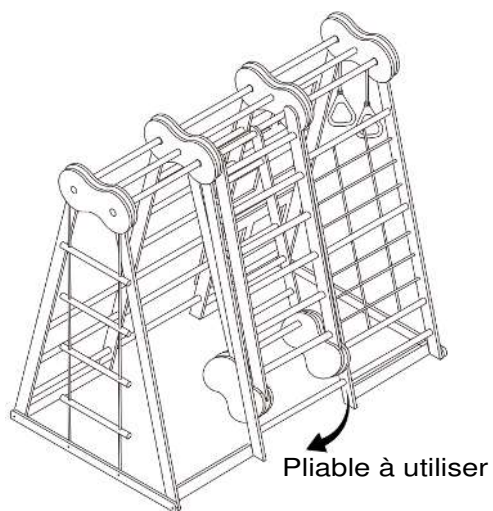

Étape7

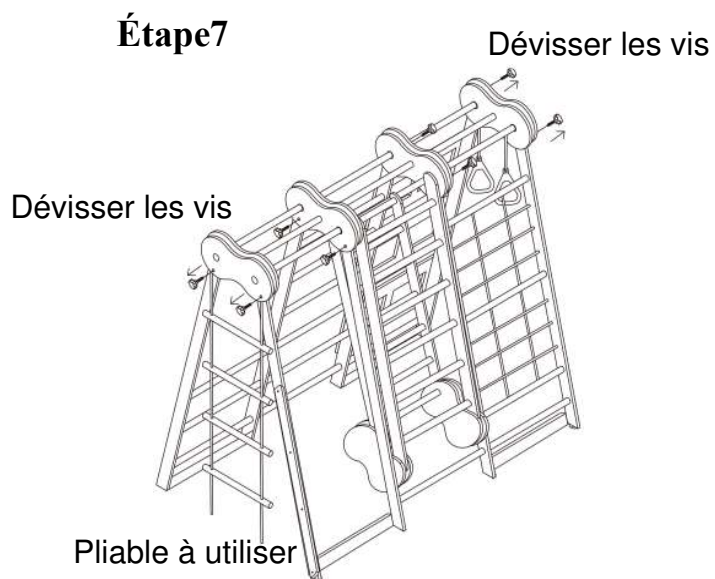

Étape5

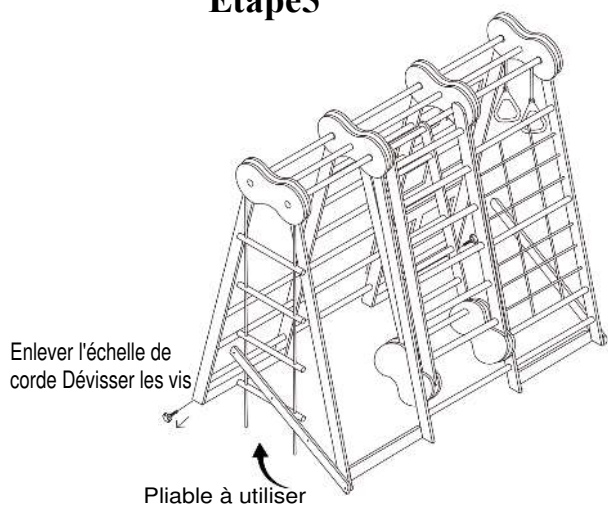

Étape8

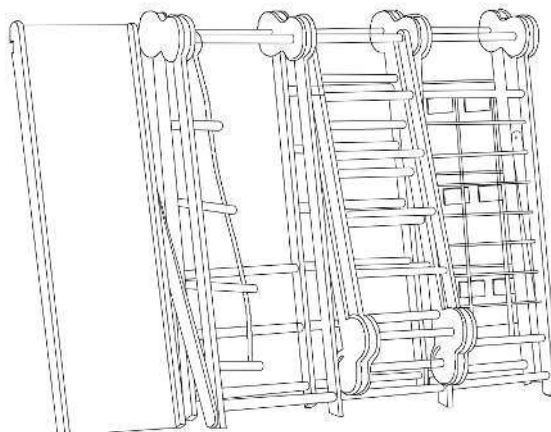

Étape6



ASSEMBLER

INSTRUCTIONS GÉNÉRALES DE SÉCURITÉ

1. Ce produit est destiné à un usage intérieur, extérieur, domestique et domestique uniquement. il n'est pas adapté à un usage commercial ou médial.
2. l'assemblage du produit doit être effectué avec soin et par un adulte valide. en cas de doute, demandez à une personne techniquement qualifiée.
3. Ne pas utiliser le produit s'il est endommagé ou défectueux. s'il est endommagé ou défectueux, contacter un technicien qualifié.
4. Vérifiez le produit avant chaque utilisation. Les pièces défectueuses doivent être remplacées immédiatement car elles peuvent nuire au fonctionnement et à la sécurité du produit.
5. N'utiliser le produit que sur des surfaces planes et non glissantes. Gardez suffisamment d'espace autour du produit pour assurer la sécurité.
6. Sachez que l'utilisation d'outils et les travaux techniques présentent toujours un risque de blessure. Assemblez le produit avec soin.
7. Après avoir installé le produit conformément au manuel d'instructions, assurez-vous que toutes les vis, tous les boulons et tous les écrous sont correctement installés et serrés et que toutes les articulations sont sûres.
8. Ne pas modifier le produit. N'utilisez que des pièces de rechange d'origine. Seuls des techniciens qualifiés peuvent effectuer des réparations - des réparations incorrectes peuvent

être dangereuses pour l'utilisateur.

IMPORTANT

Le produit doit être assemblé par un adulte qui a lu et compris ces instructions. Le produit doit être assemblé par un adulte qui a lu et compris ces instructions. Gardez l'emballage hors de portée des enfants et éliminez tous les emballages avant utilisation.

ASSEMBLER

INSTRUCTIONS D'UTILISATION

1. Assurer la surveillance d'un adulte à tout moment.
 2. Le produit démonté contient de petites pièces qui présentent un risque d'étouffement pour les enfants de moins de 3 ans.
 3. Habillez les enfants de manière appropriée, notamment en portant des chaussures bien ajustées qui protègent entièrement les pieds.
 4. donner des instructions aux enfants :
 - de s'asseoir au centre de la balançoire en pesant de tout leur poids sur les sièges
 - d'éviter de se balancer sur des sièges vides,
 - de glisser les pieds en premier ; un enfant à la fois sur le toboggan,
 - d'enlever, avant de jouer sur l'équipement, les objets qui créent des risques lorsqu'ils s'emmêlent et s'accrochent.
 - ne pas marcher près, devant, derrière ou entre des objets en mouvement,
 - ne pas descendre de l'équipement lorsqu'il est en mouvement.
- Ne jamais permettre aux enfants d'utiliser l'équipement d'une manière autre que celle prévue. Ne pas se balancer en restant debout ou glisser la tête la première.



Test Report

No.: 70.452.24.32883.01

Date: 2024-08-29

Applicant: DECOBUS HANDEL GMBH
Address: INNUNGSSTRASSE 9, 21244 BUCHHOLZ, DEUTSCHLAND
Manufacturer: CAO COUNTY MINGCHAO WOOD PRODUCTS CO., LTD.
Product Name: Klettergerüst für Kinder
Model No.: WF1973478A
Labelled Age Range: Not stated
Age range in testing: Over 3 years
Age Group Assessed As per Age Guideline: Over 3 years
Receipt Date of Sample: 2024-07-11
Date of Testing: 2024-07-11 ~ 2024-08-29
Sample Submitted: The sample(s) was (were) submitted by applicant and identified.
Test Result: Refer to the data listed in following pages

Test Item	Conclusion
1. EN 71-1:2014+A1:2018 Mechanical and Physical Properties Excluding the requirement of clause 4.2 & 7	Pass
2. EN 71-2:2020 Flammability	Pass
3. EN 71-3:2019+A1:2021- Migration of certain elements	Pass
4. EN 71-8:2018 Activity toys for domestic use Excluding the requirement of clause 4.2.2 & 4.3.1 & 4.3.2 & 4.4.3 & 4.6.5 & 4.6.7 & 4.6.8 & 5	Pass

Remarks: 1. MDL = Method Detection Limit
 2. ND = Not Detected (<MDL)
 3. ≤ Less than
 4. 1 mg/kg = 1 ppm = 0.0001%
 5. NA=Not Applicable

TÜV SÜD Certification and Testing (China) Co., Ltd. Shanghai Branch
 Testing Center

Prepared by:

Rainie Dai
 Reporting Representative



Authorized by:

Neko Ding
 Director

Note:

- The TÜV SÜD Certification and Testing (China) Co., Ltd. "General Terms & Conditions" applied. Any use for advertising purposes must be granted in writing. This technical report may only be quoted in full. This report is the result of a single examination of the object in question. It does not imply a general statement regarding the quality of products from regular production. For further details please see "Testing, Certification, Validation and Verification Regulations", chapter A-3.3. For full version, please visit: EN : <https://www.tuvsud.cn/zh-cn/resource/terms-and-conditions---en> ; SCN: <https://www.tuvsud.cn/zh-cn/terms-and-conditions> ; TCN: <https://www.tuvsud.com/zh-tw/terms-and-conditions>
- The results relate only to the Items tested.
- The test report shall not be reproduced except in full without the written approval of the laboratory
- Disclaimer Measurement Uncertainty:
 Unless otherwise agreed upon, Pass or Fail verdicts are given based on the measured values without any considerations of measurement uncertainties.
 Please note, every test method has a measurement uncertainty which has been evaluated by the laboratory according to ISO/IEC 17025 requirements. By taking measurement uncertainties into account it might happen that measured values can neither be assessed as Pass nor as Fail.