

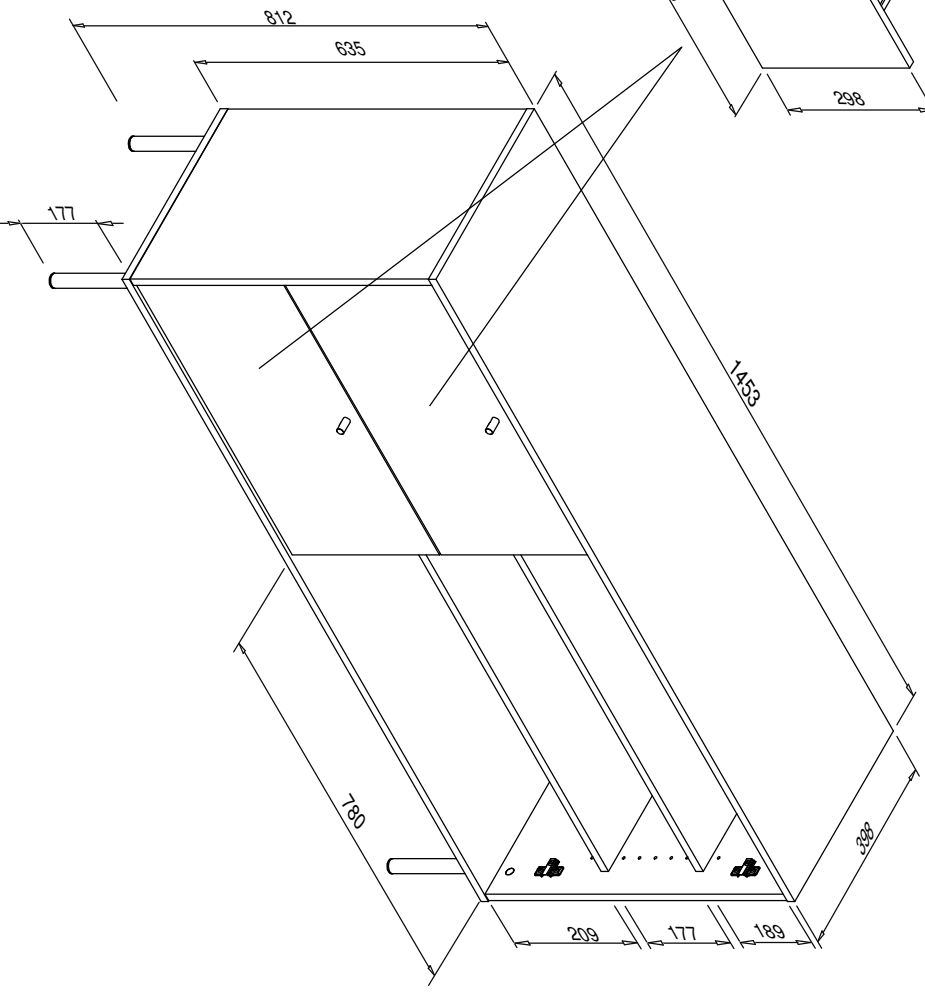

LCA51A/018

finori GmbH
Straßäcker 2
D - 96253 Untersiemau

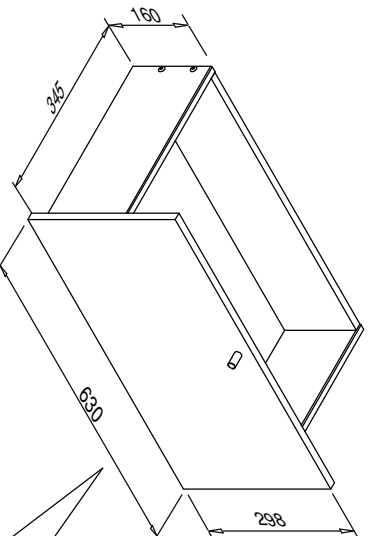

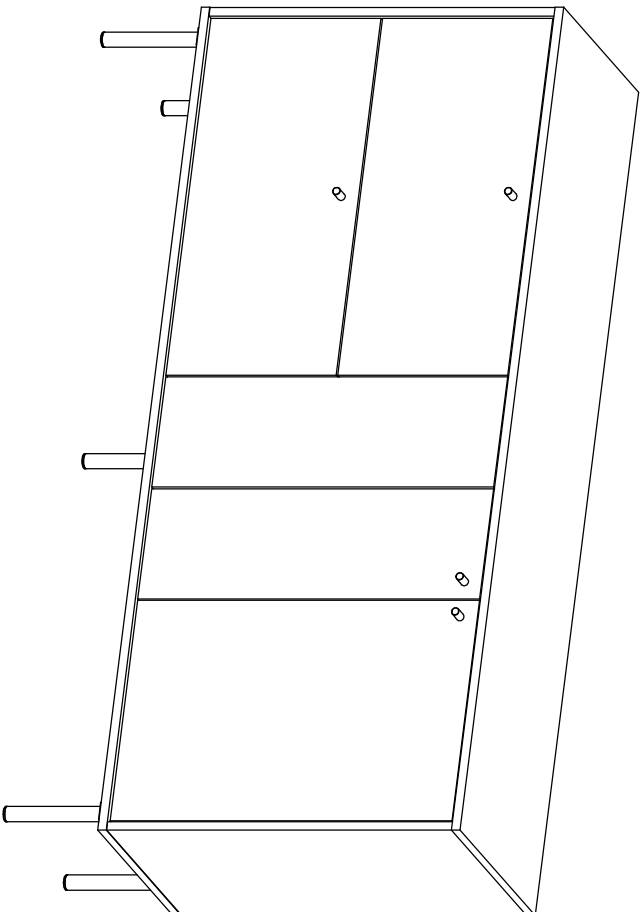

- ⓓ Befolgen Sie stets die Anleitung des Herstellers!
- ⒸⒷ Please generally follow the manufacturer's instructions!
- ⒻⓇ Suivez toujours les instructions du fabricant!
- ⓃⓁ Volg steeds de handleiding van de producent!
- ⒺⓈ Siga siempre las instrucciones del fabricante!
- ⓇⓁ Stale przestrzegaj instrukcji producenta!

- ⓇⓁ Всегда следуйте инструкции производителя!
- ⓇⓇ Seguire sempre le istruzioni del produttore!
- ⓇⓇ Mindig tartsa be a gyártó utasításait!
- Ⓡ Siga sempre as instruções do fabricante!
- ⒸⓏ Vždy dodržujte pokyny výrobce!



- ⓓ Verwenden Sie zur Reinigung nur ein feuchtes Tuch!
- ⒸⒷ Please only clean with a damp cloth!
- ⒻⓇ N'utilisez qu'un chiffon humide pour le nettoyage!
- ⓃⓁ Gebruik voor de reiniging enkel een vochtige doek!
- ⒺⓈ Para limpiar utilice sólo un paño húmedo!
- ⓇⓁ Do czyszczenia używaj wilgotnej szmatki!

- ⓇⓁ Для очистки используйте только влажную ткань!
- ⓇⓇ Per la pulizia, utilizzare solo un panno umido!
- ⓇⓇ A tisztításhoz elegendő egy nedves kendő használatát!
- Ⓡ Para a limpeza use apenas um pano húmido!
- ⒸⓏ Pro čištění používejte pouze vlhký hadřík!

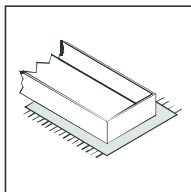

- ⓓ Bauen Sie das Produkt auf einer Unterlage auf!
- ⒸⒷ Please mount the product on a bottom support!
- ⒻⓇ Montez le produit sur une base!
- ⓃⓁ Monteer het product op een basis!
- ⒺⓈ Monte el producto sobre una base!
- ⓇⓁ Rozkładaj produkt na podkładce!

- ⓇⓁ Собирайте изделие на подстилке!
- ⓇⓇ Montare il prodotto su un supporto!
- ⓇⓇ Az összeszereléskor helyezzen a termék alá megfelelő alátétet!
- Ⓡ Monte o produto numa superfície plana!
- ⒸⓏ Výrobek smontujte na pevném podkladu!



- ⓓ Verwenden Sie das Produkt nur in Innenräumen!
- ⒸⒷ Please exclusively use the product indoors!
- ⒻⓇ N'utilisez le produit qu'à l'intérieur!
- ⓃⓁ Gebruik het product enkel binnenshuis!
- ⒺⓈ Utilice el producto sólo en interiores!
- ⓇⓁ Używaj produkt tylko w pomieszczeniach wewnętrznych!

- ⓇⓁ Используйте изделие только во внутренних помещениях!
- ⓇⓇ Utilizzare il prodotto solo in ambienti interni!
- ⓇⓇ A termék csak bel terekben használható!
- Ⓡ Use o produto apenas no interior!
- ⒸⓏ Používejte výrobek pouze uvnitř!

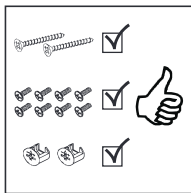

- ⓓ Legen Sie die Beschläge zusammen und prüfen Sie die Vollständigkeit!
- ⒸⒷ Please join the fittings and verify their completeness!
- ⒻⓇ Pliez les raccords ensemble et vérifiez qu'ils sont complets!
- ⓃⓁ Leg de onderdelen samen en controleer de volledigheid!
- ⒺⓈ Junte los accesorios y compruebe que están todos!
- ⓇⓁ Rozłóż poszczególne części i sprawdź kompletność!

- ⓇⓁ Положите фурнитуру в одно место и проверьте комплектность!
- ⓇⓇ Mettere insieme le guarnizioni e verificarne la completezza!
- ⓇⓇ Állítsa össze a sarokvasakat, és ellenőrizze, hogy épek-e!
- Ⓡ Coloque os encaixes juntos e verifique se estão completos!
- ⒸⓏ Složte armatury a zkontrolujte úplnost!



- ⓓ Bei fehlenden Teilen kontaktieren Sie den Hersteller!
- ⒸⒷ If parts are missing, please turn to the manufacturer!
- ⒻⓇ En cas de pièces manquantes, veuillez contacter le fabricant!
- ⓃⓁ Contacteer de fabrikant als er onderdelen ontbreken!
- ⒺⓈ En el caso de que falten piezas, póngase en contacto con el fabricante!
- ⓇⓁ W razie braku części skontaktuj się z producentem!

- ⓇⓁ При отсутствии каких-либо частей обратитесь к производителю!
- ⓇⓇ In caso di pezzi mancanti, contattare il produttore!
- ⓇⓇ Ha hiányozna valamelyik elem, lépjen kapcsolatba a gyártóval!
- Ⓡ Em caso de peças em falta, entre em contato com o fabricante!
- ⒸⓏ Pro chybějící díly kontaktujte výrobce!

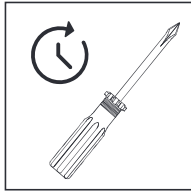

- ⓓ Ziehen Sie die Schrauben nach einiger Zeit des Gebrauchs erneut fest!
- ⒸⒷ Please re-tighten the screws after having used the product for a while!
- ⒻⓇ Resserrer les vis après un certain temps d'utilisation!
- ⓃⓁ Draai de schroeven na een zekere gebruikstijd opnieuw vast!
- ⒺⓈ Asegure de nuevo los tornillos tras usarlo durante un tiempo!
- ⓇⓁ Po pewnym czasie użytkowania ponownie dokręć śruby!

- ⓇⓁ Спустя некоторое время использования подкрутите гайки!
- ⓇⓇ Stringere nuovamente le viti dopo un certo periodo di utilizzo!
- ⓇⓇ A használat során némi idő elteltével húzza meg újra a csavarokat!
- Ⓡ Reaperte os parafusos após algum tempo de uso!
- ⒸⓏ Po určité době používání šrouby znovu utáhněte!



LCA51A/018

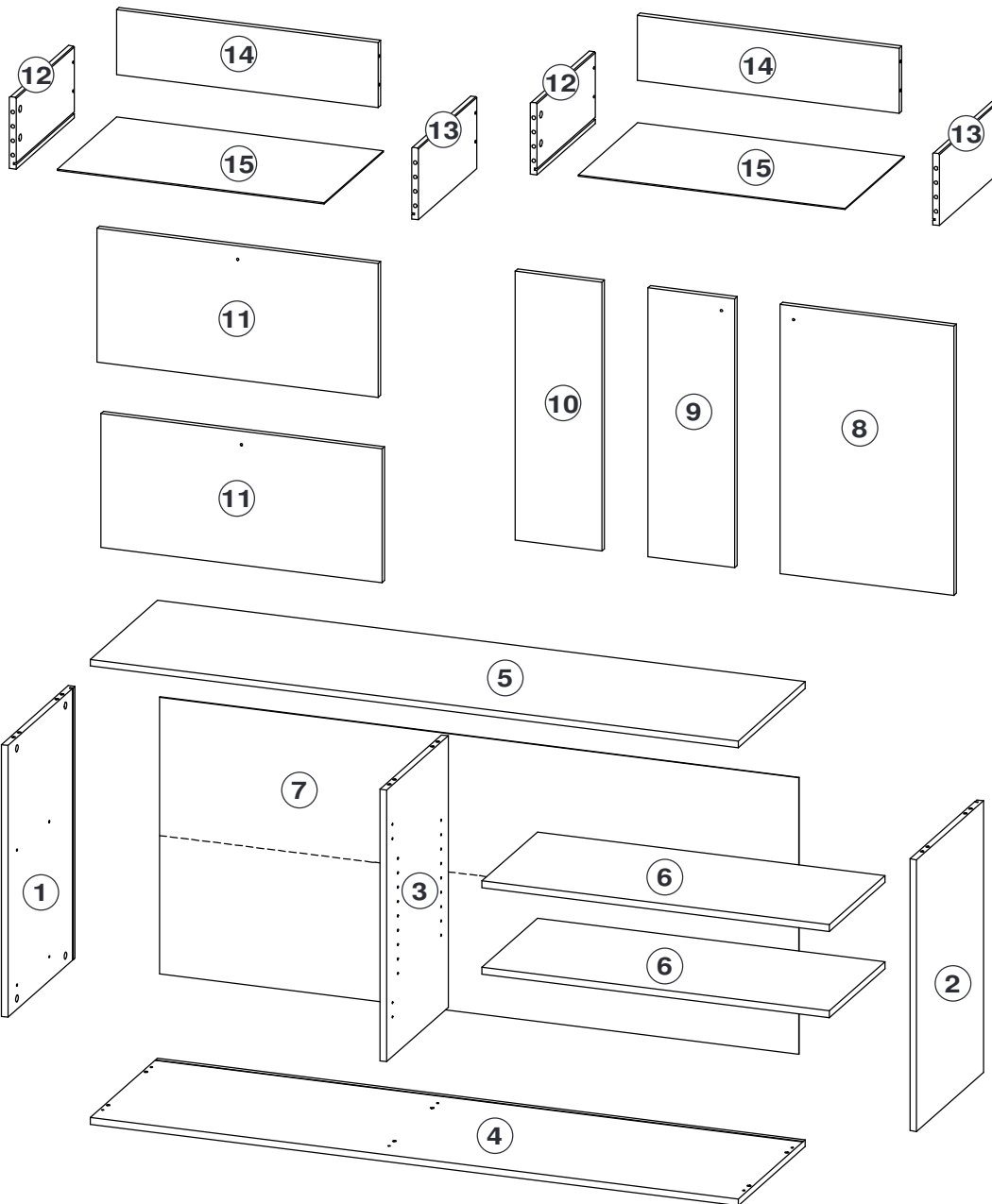
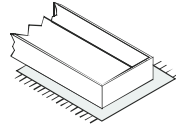
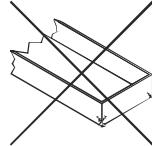
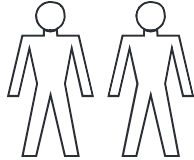
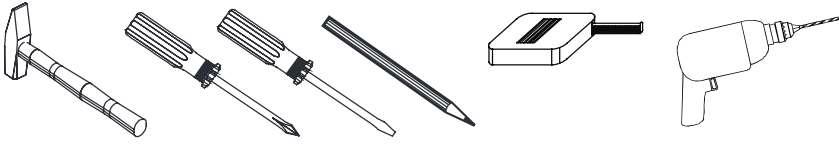

Dimensions / Abmessung in mm/		
①	1 x	605 x 397 x 15
②	1 x	605 x 397 x 15
③	1 x	605 x 365 x 15
④	1 x	1453 x 398 x 15
⑤	1 x	1453 x 398 x 15
⑥	2 x	779 x 330 x 15
⑦	1 x	1433 x 616 x 2,5
⑧	1 x	599 x 389 x 15
⑨	1 x	599 x 194,5 x 15
⑩	1 x	599 x 194,5 x 15
⑪	2 x	630 x 298 x 15
⑫	2 x	345 x 160 x 15
⑬	2 x	345 x 160 x 15
⑭	2 x	587 x 144,5 x 15
⑮	2 x	598 x 351 x 2,5

BOX 1	1, 2, 3, 6, 8, 9, 10, 11
BOX 2	4, 5, 7, 12, 13, 14, 15



BOX 1	<input checked="" type="checkbox"/>
BOX 2	<input type="checkbox"/>

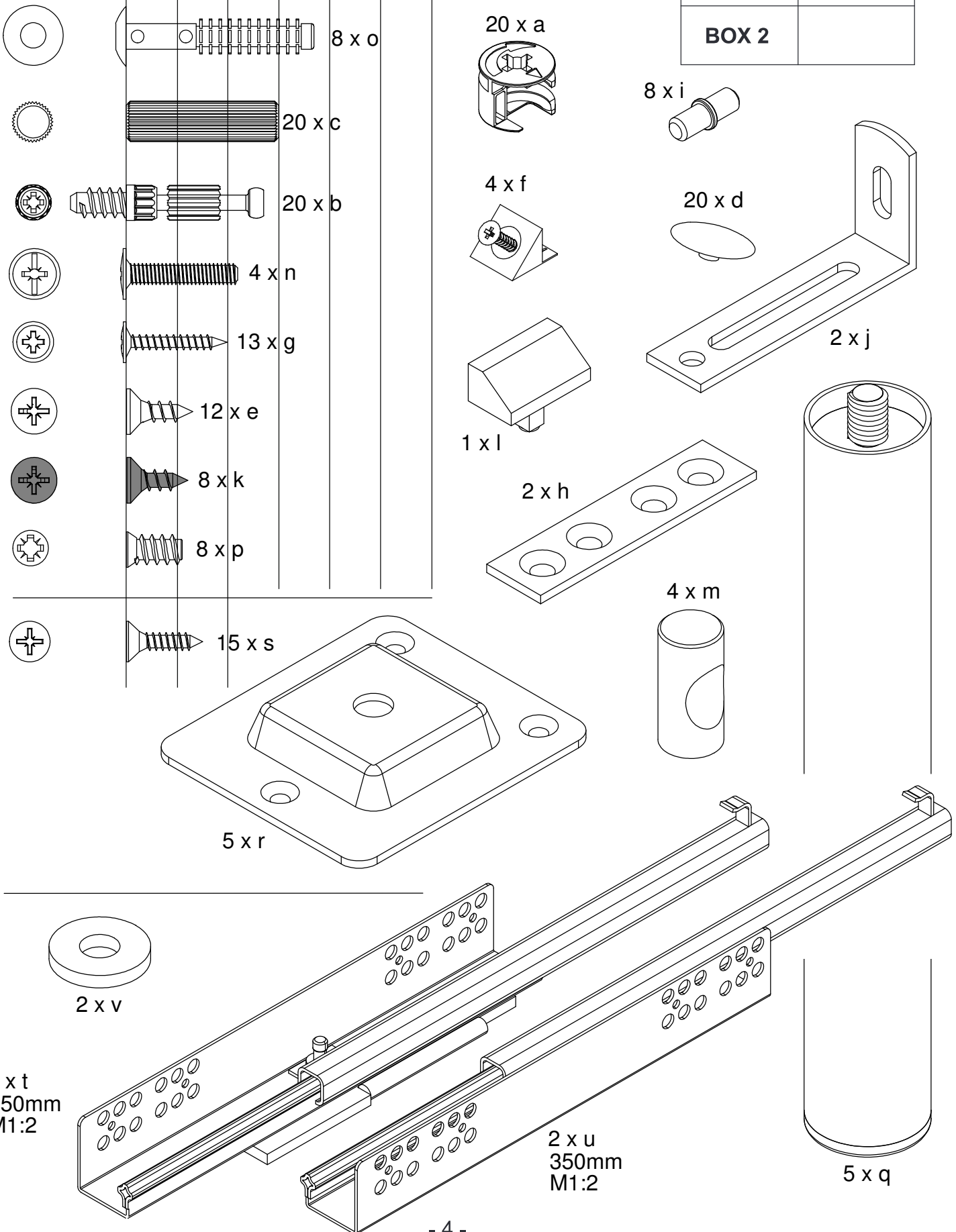

BOX 1	✓
BOX 2	

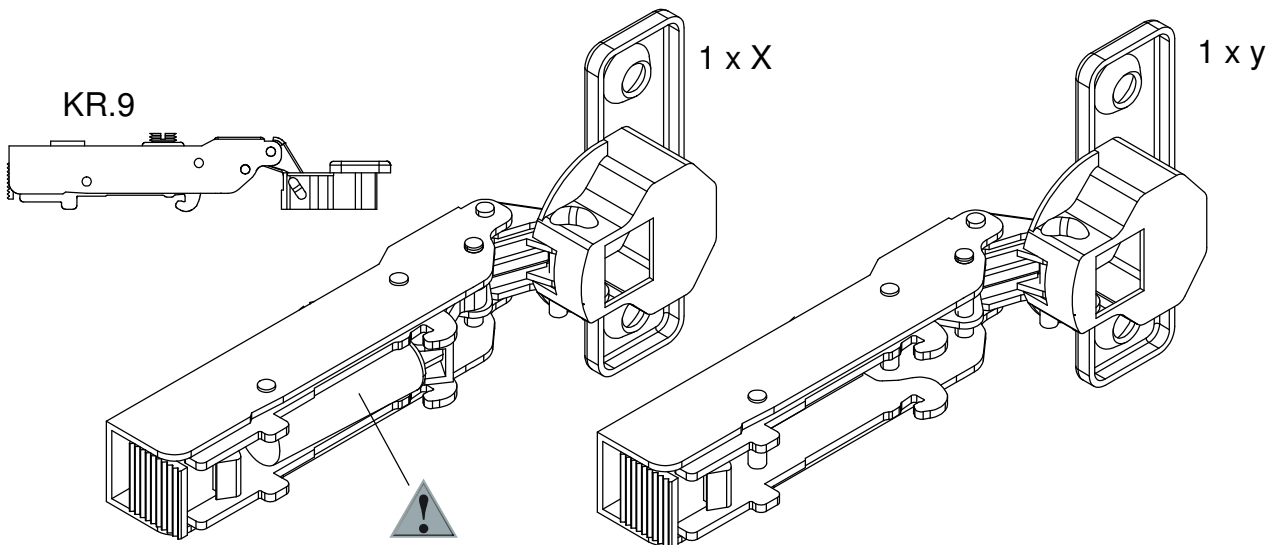
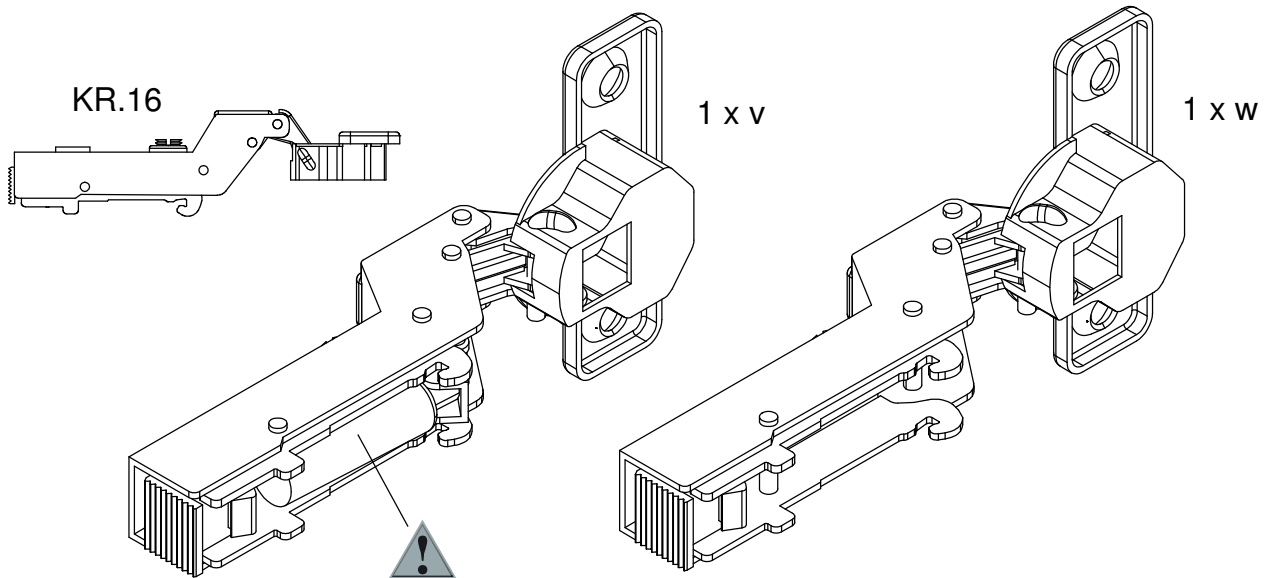
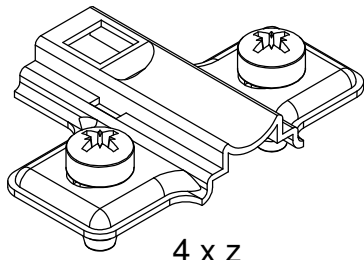

A 2x

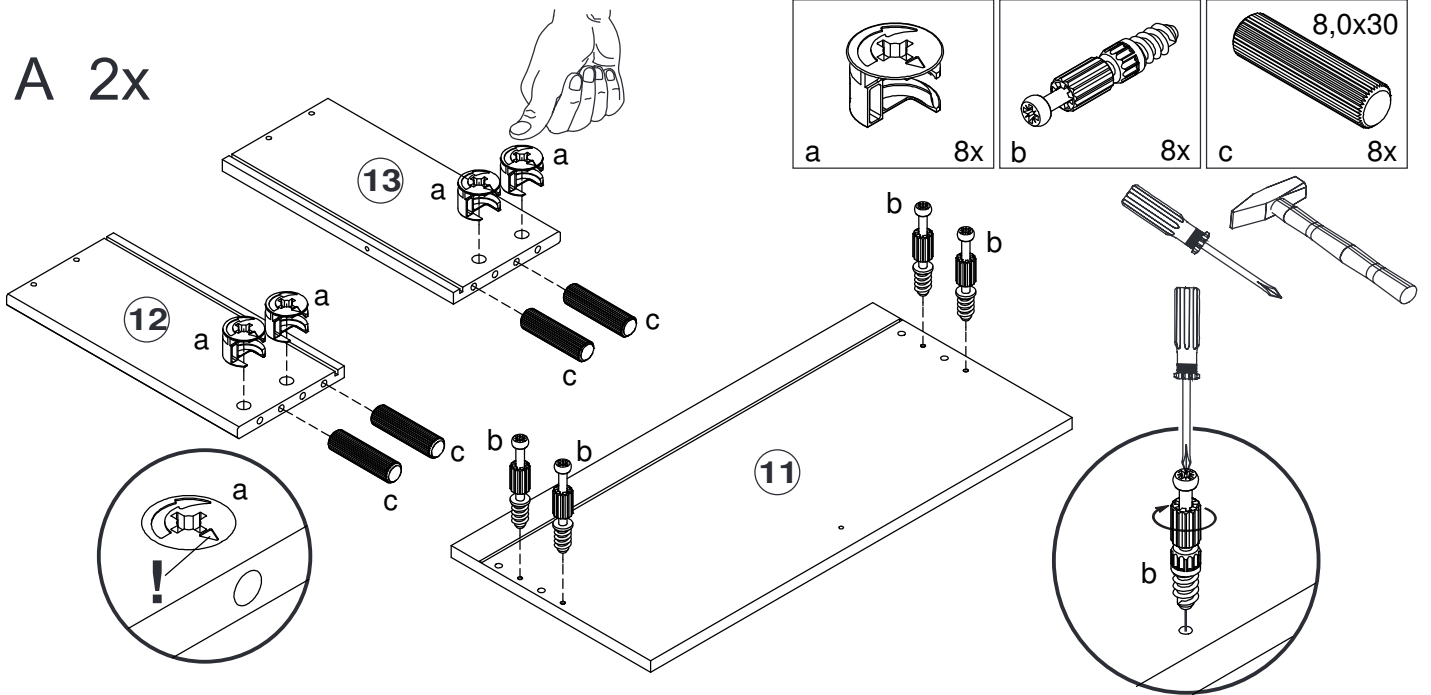

B 2x

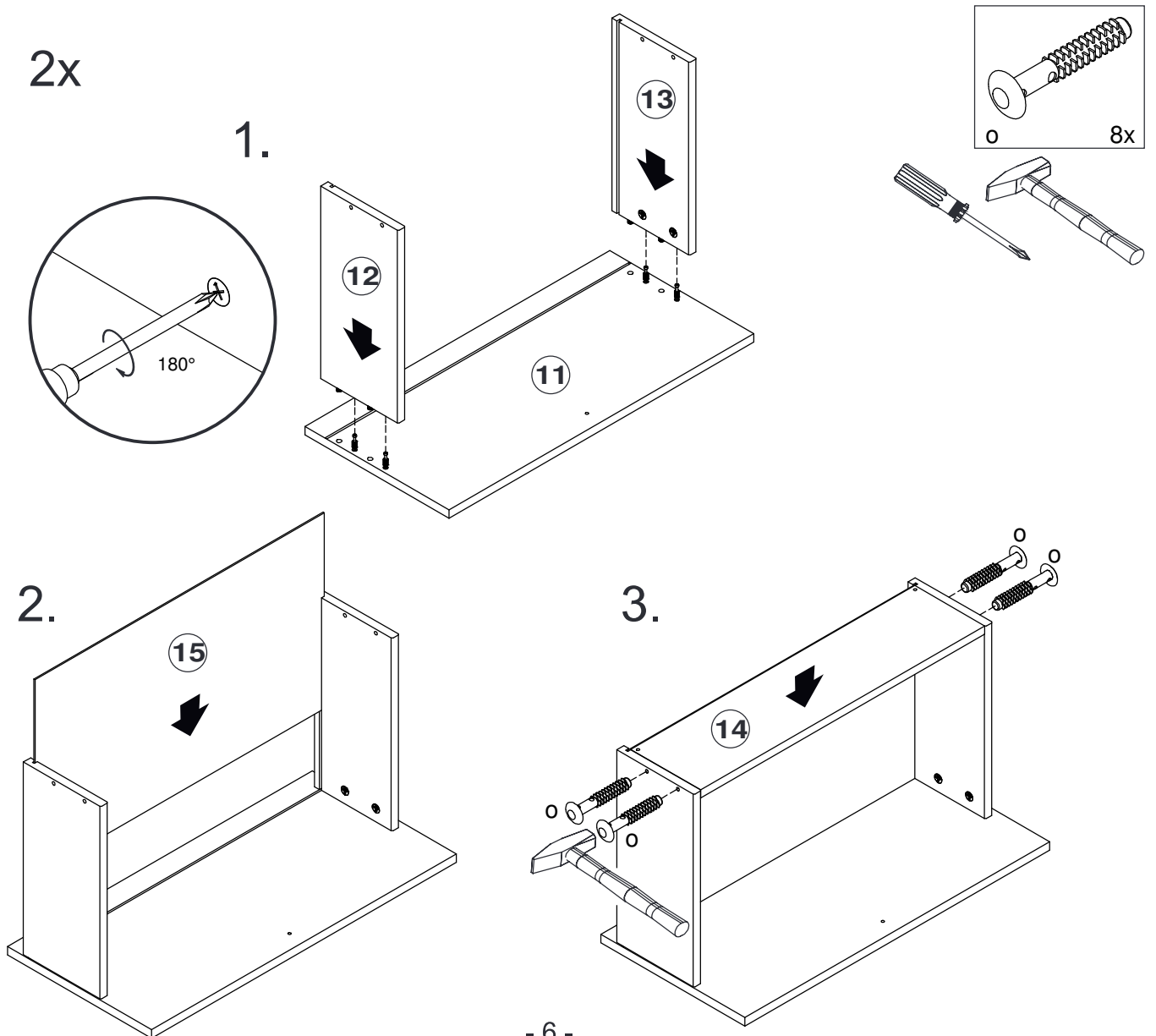

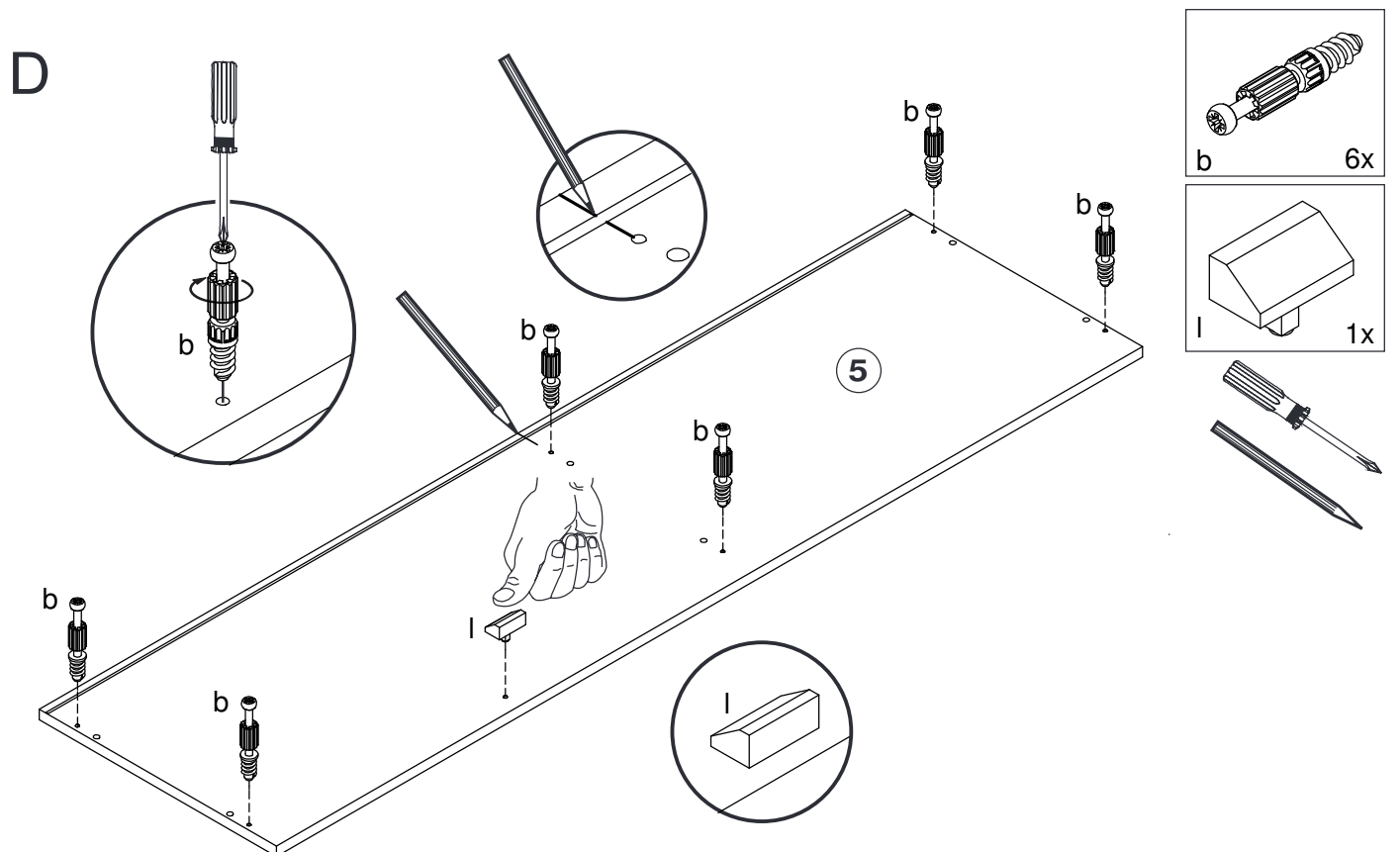
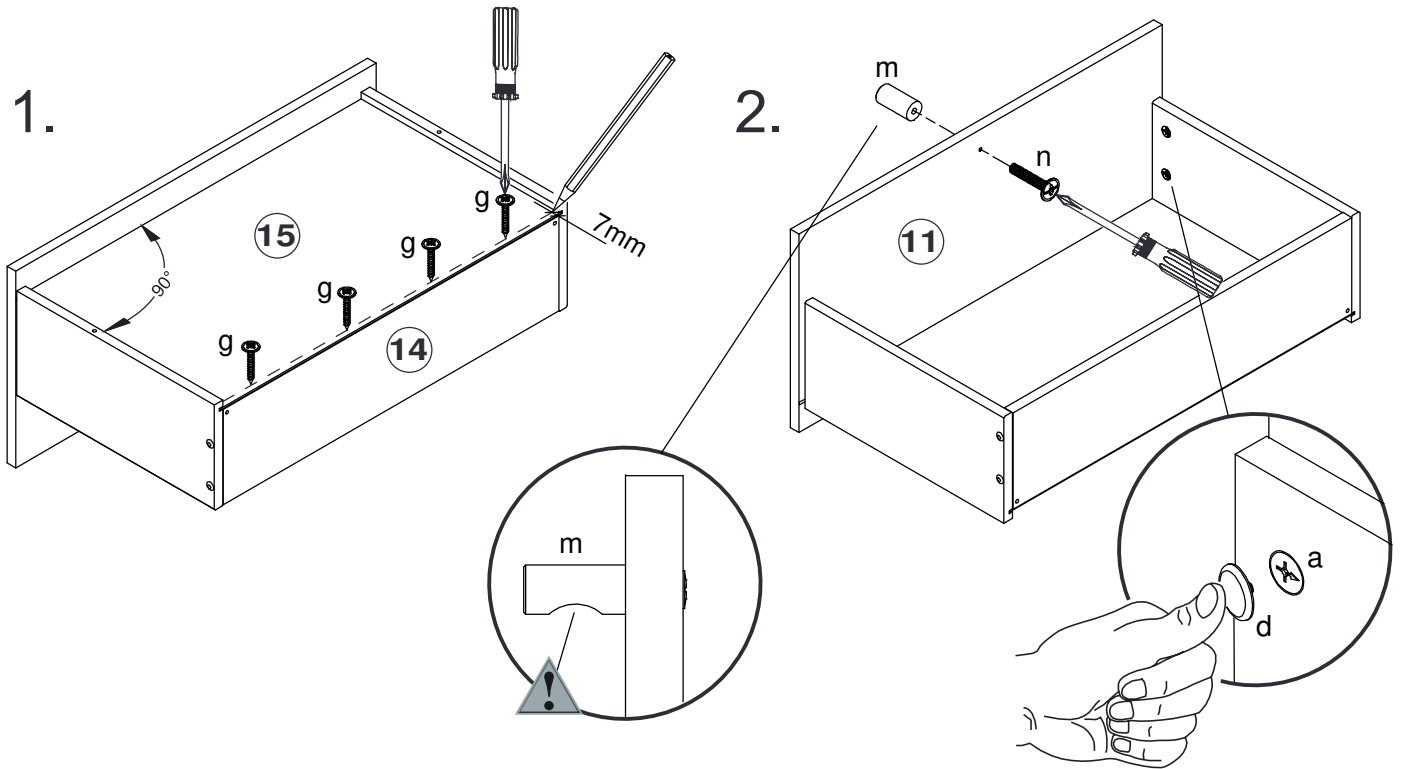
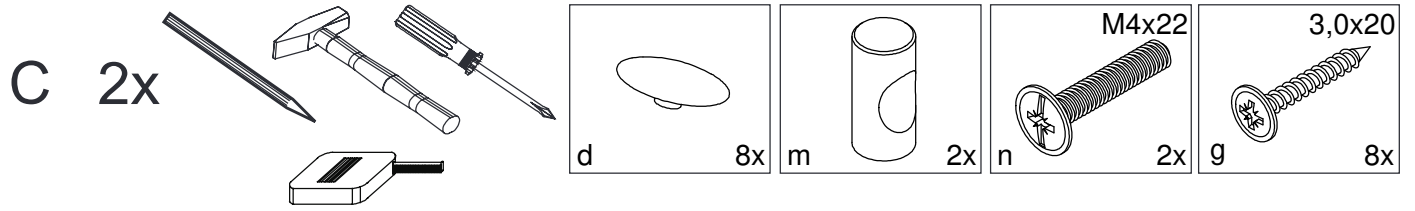

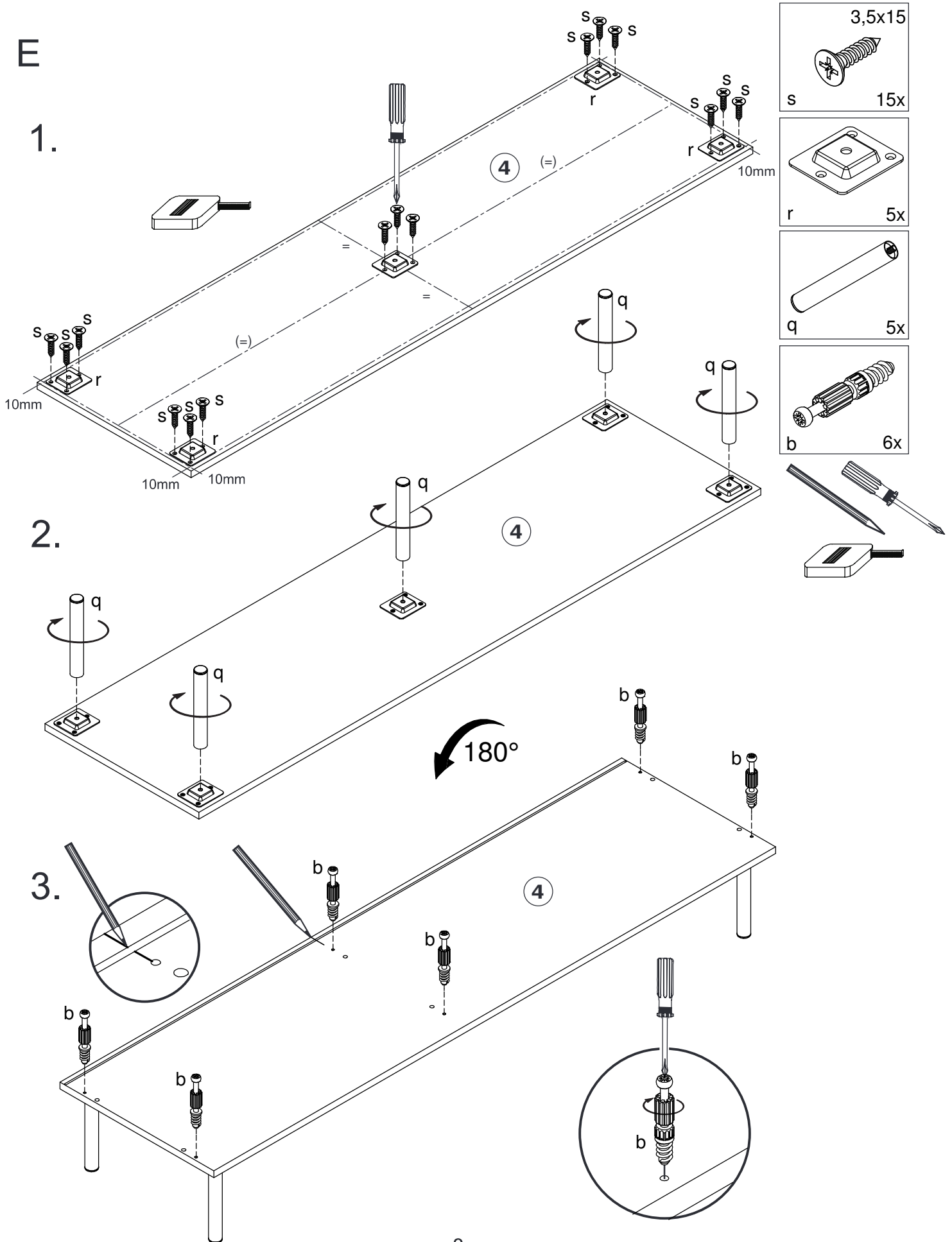

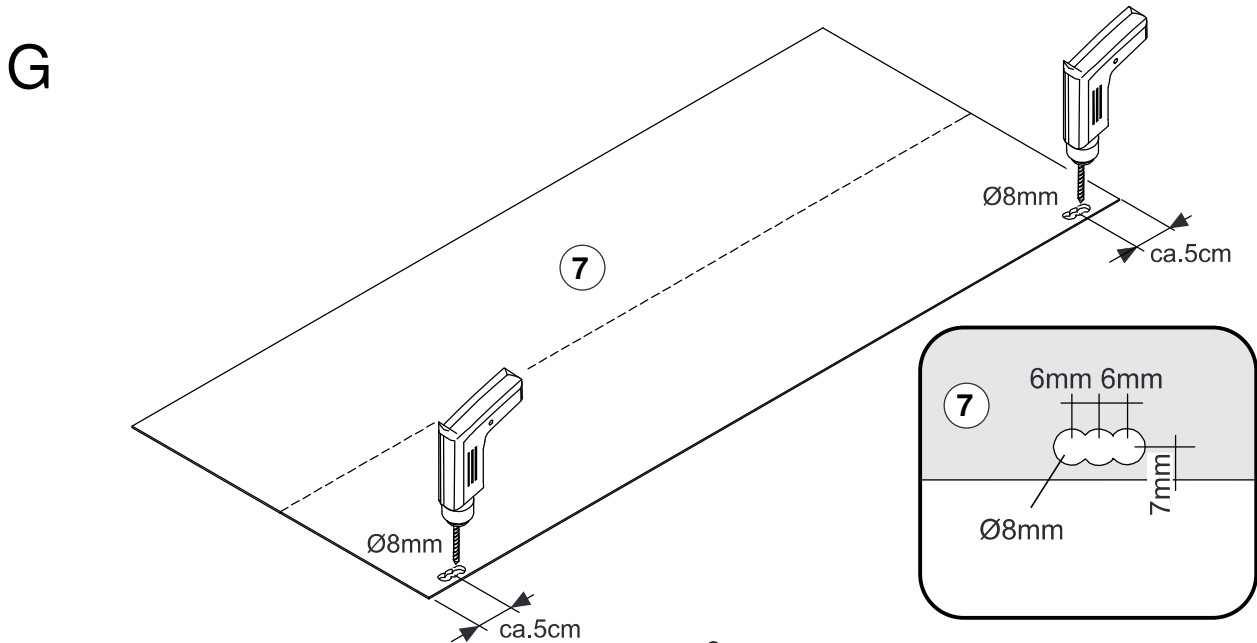
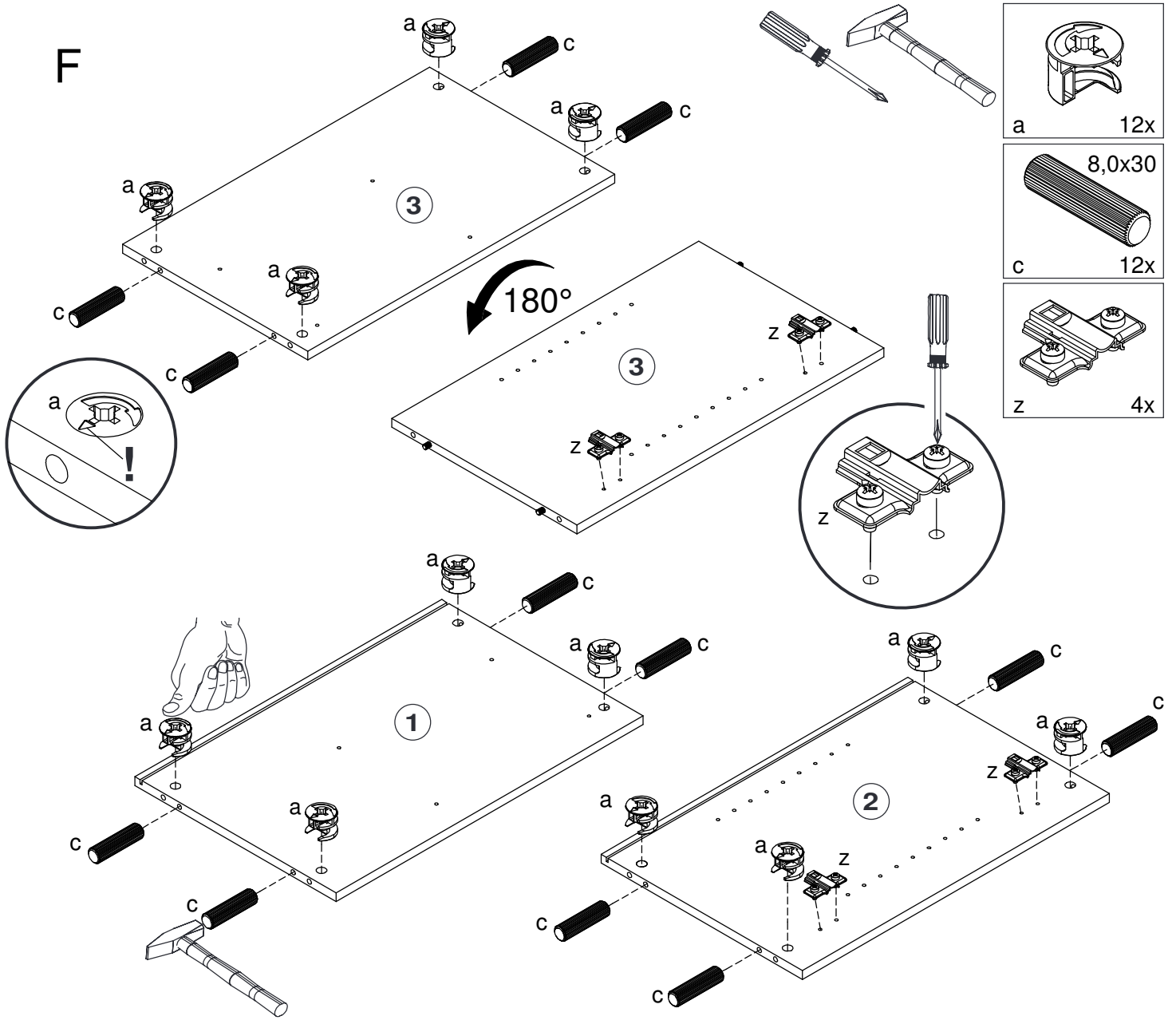

H

1.

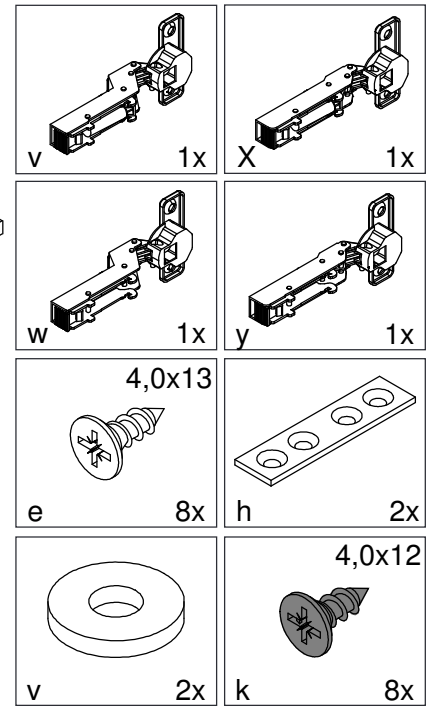
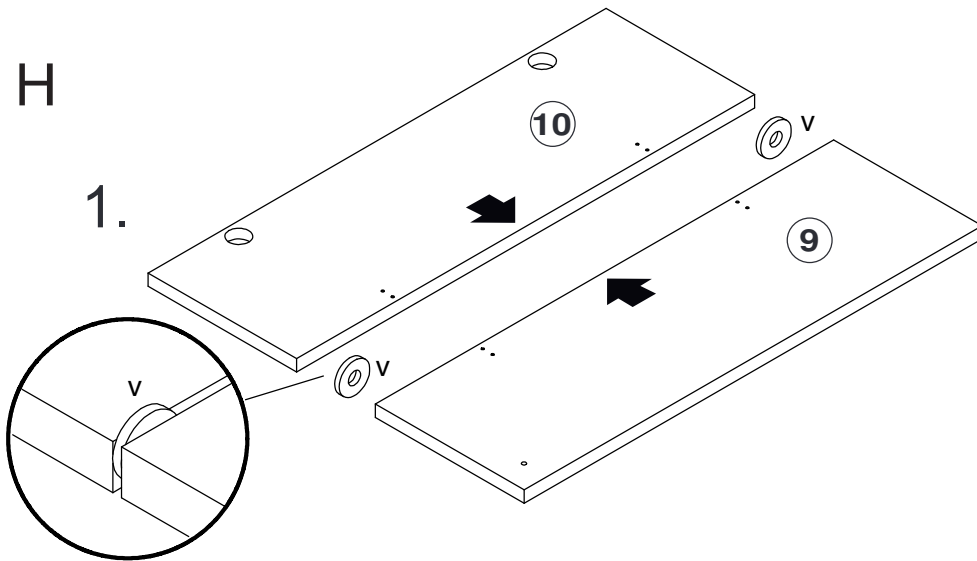

2.

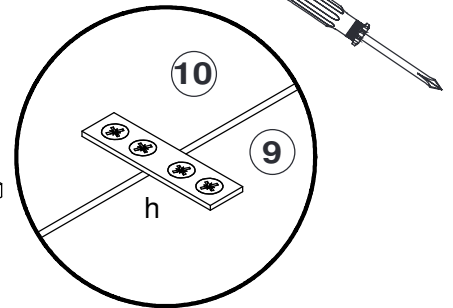
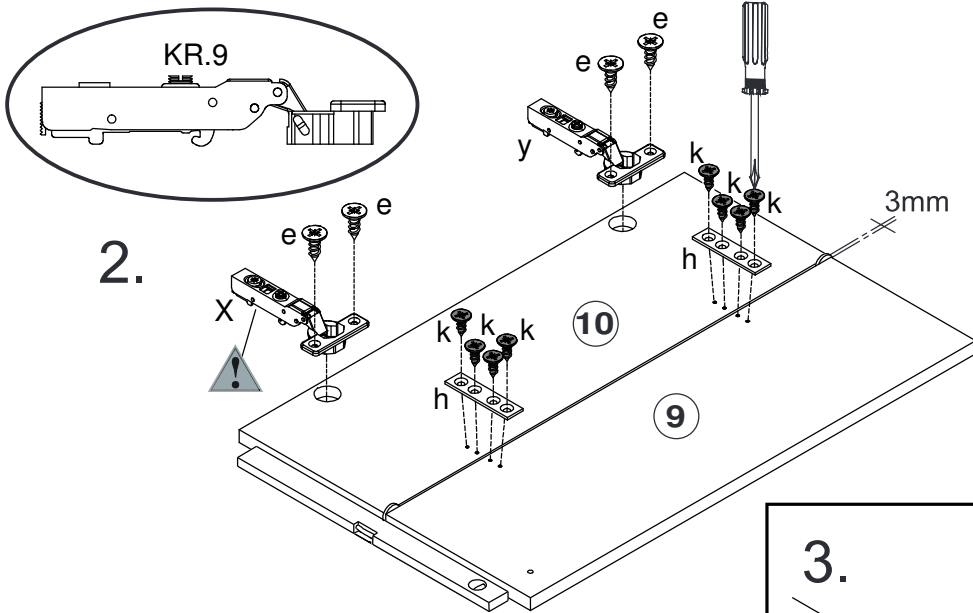

3.

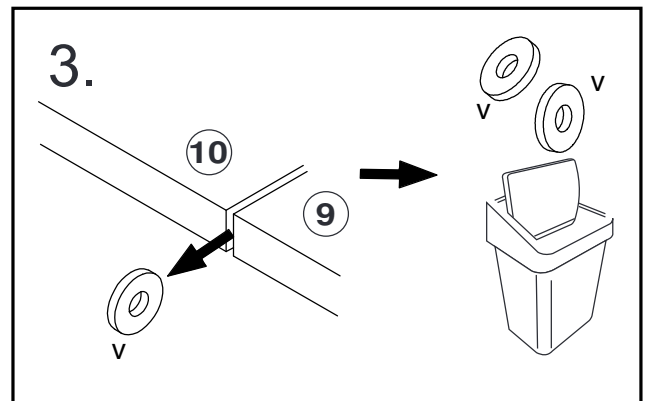

KR.16

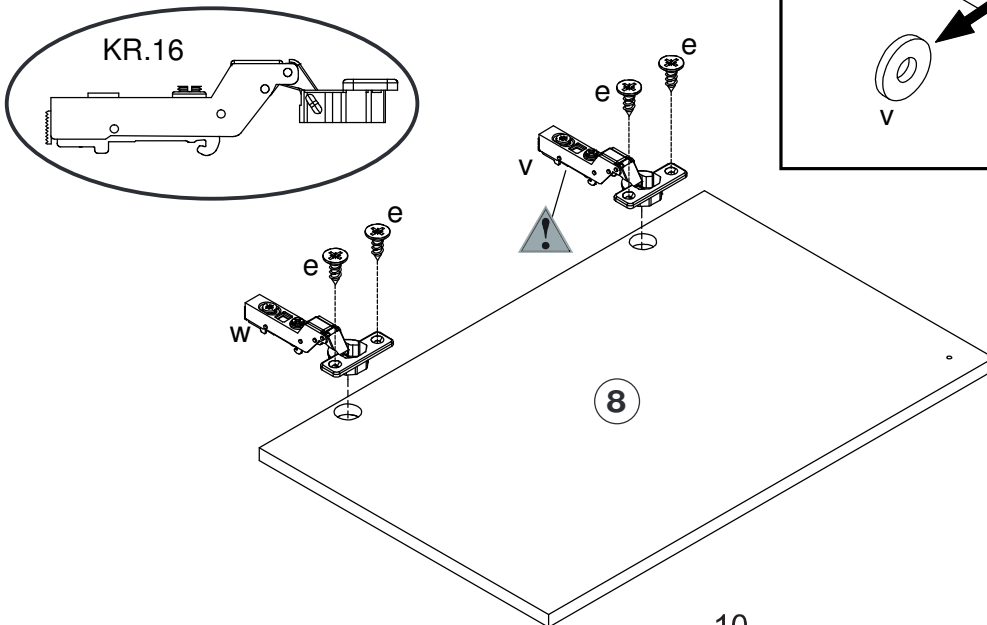

I

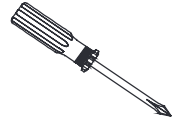
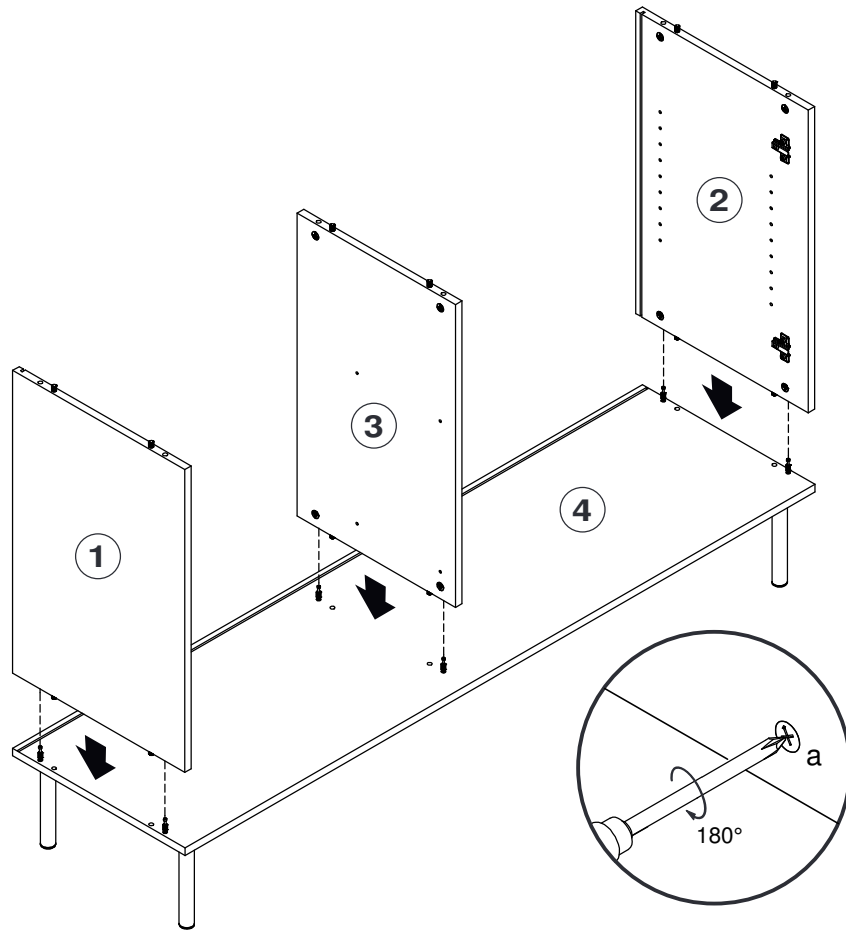

J

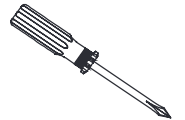
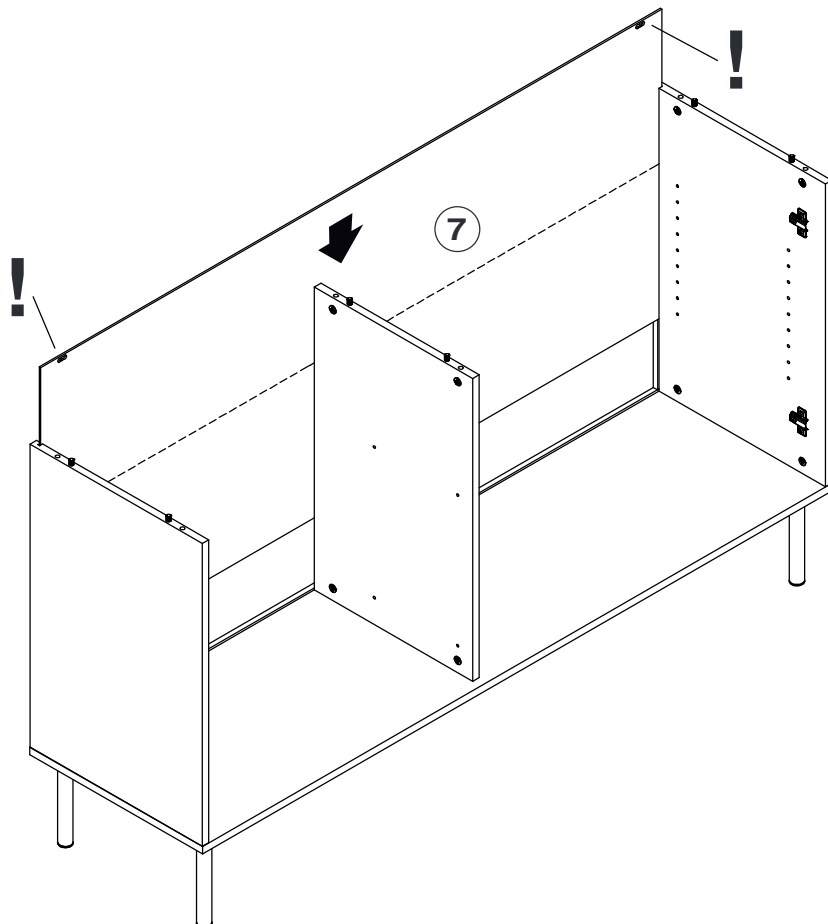

K

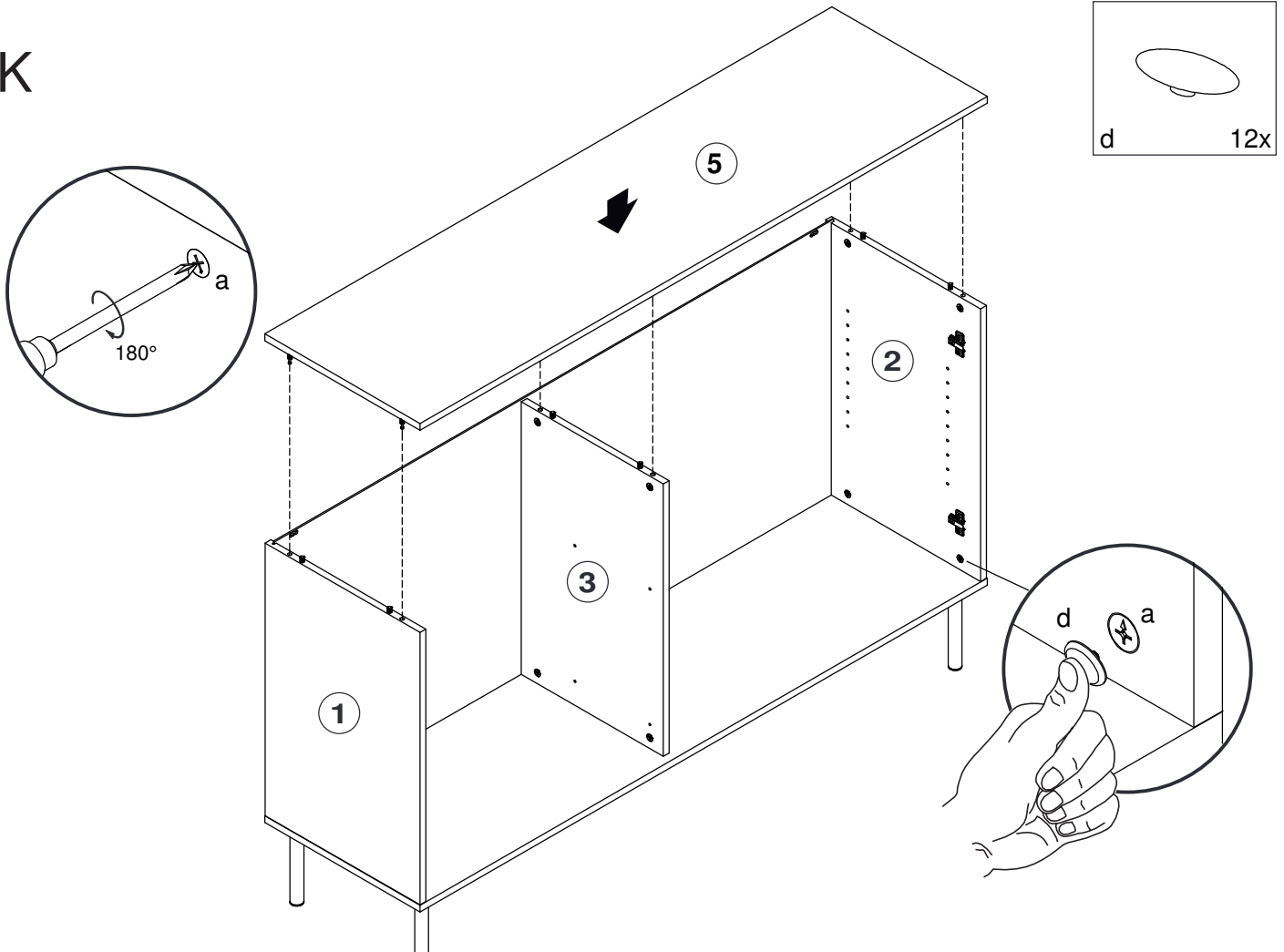

L

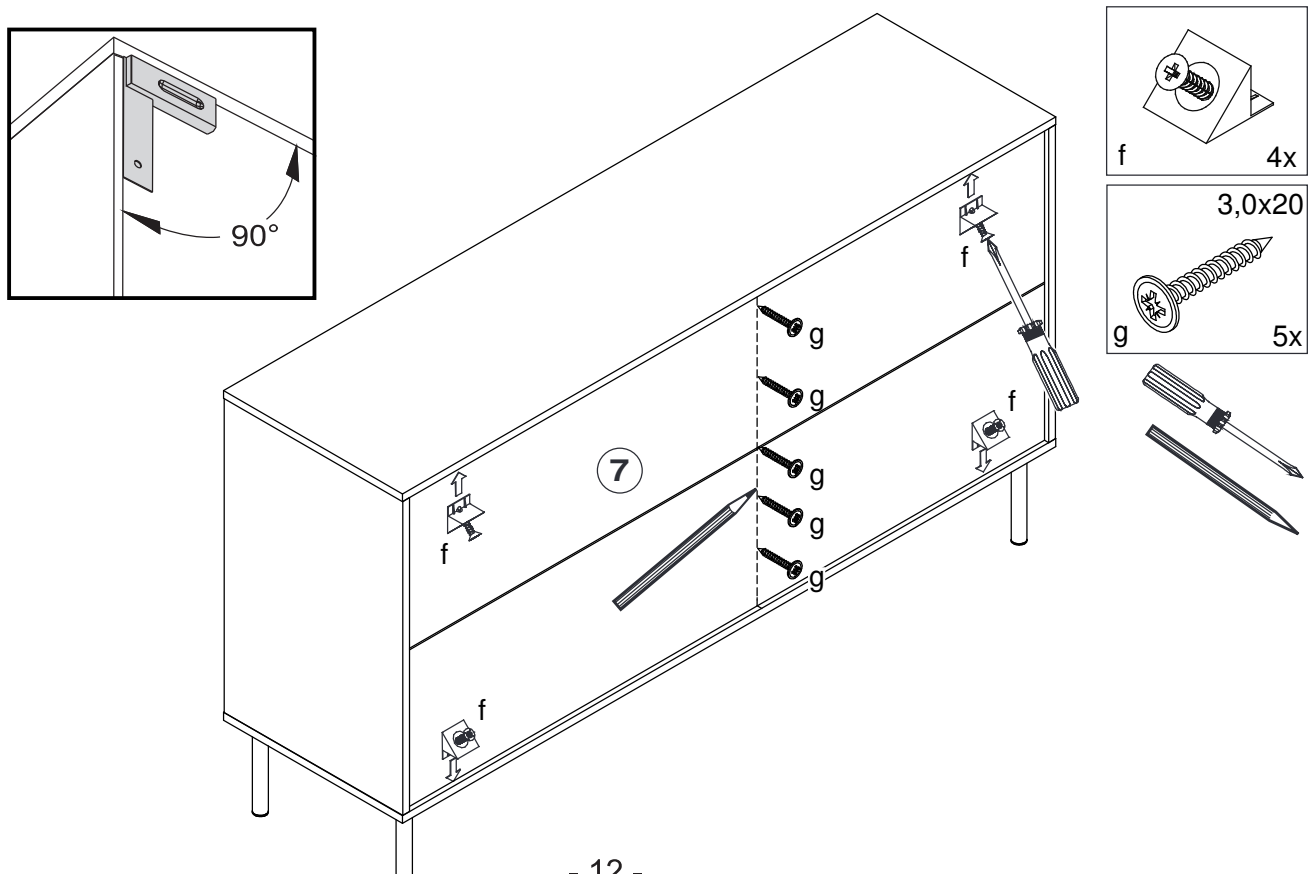

M

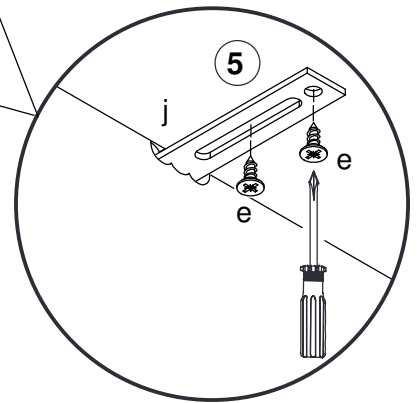
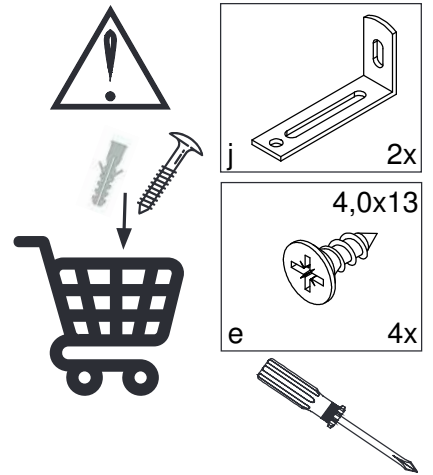
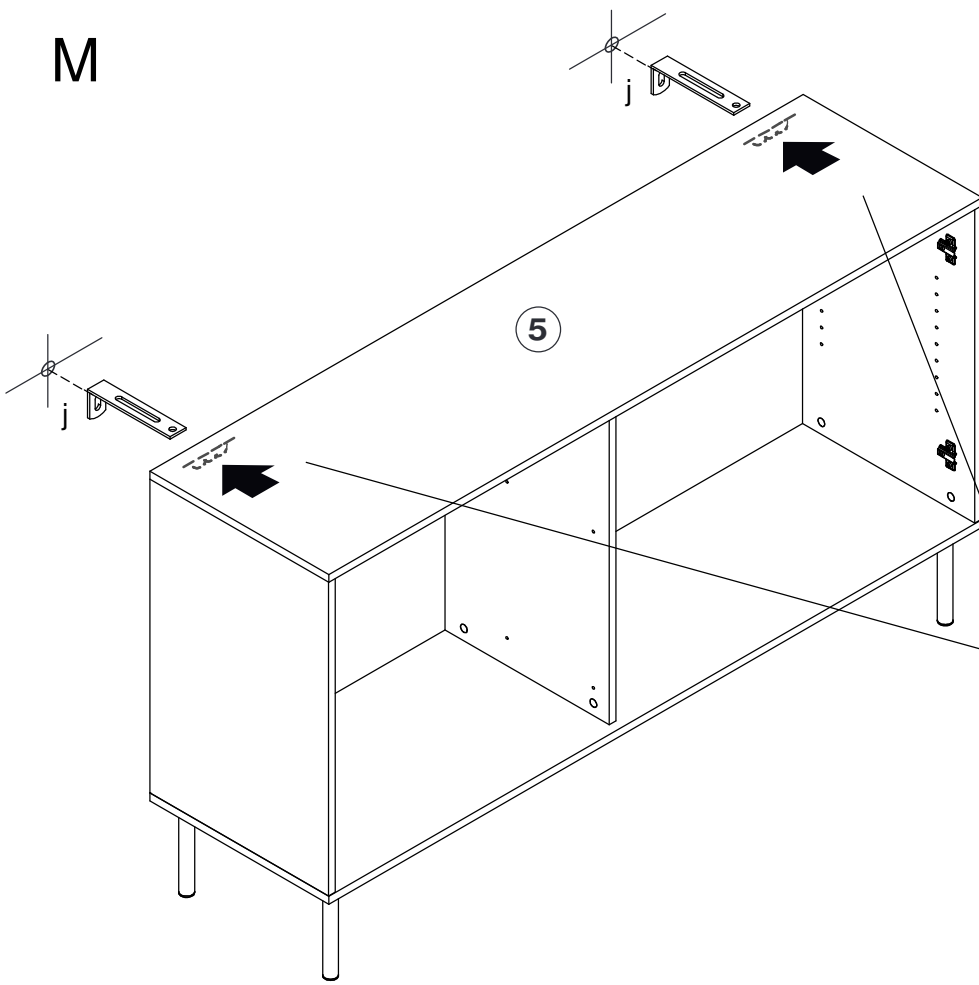

N

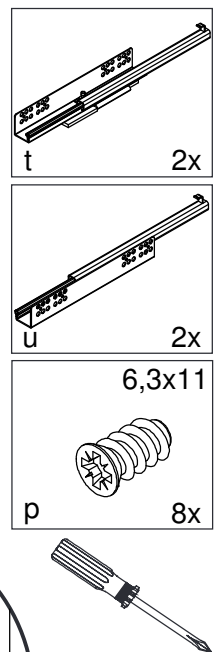
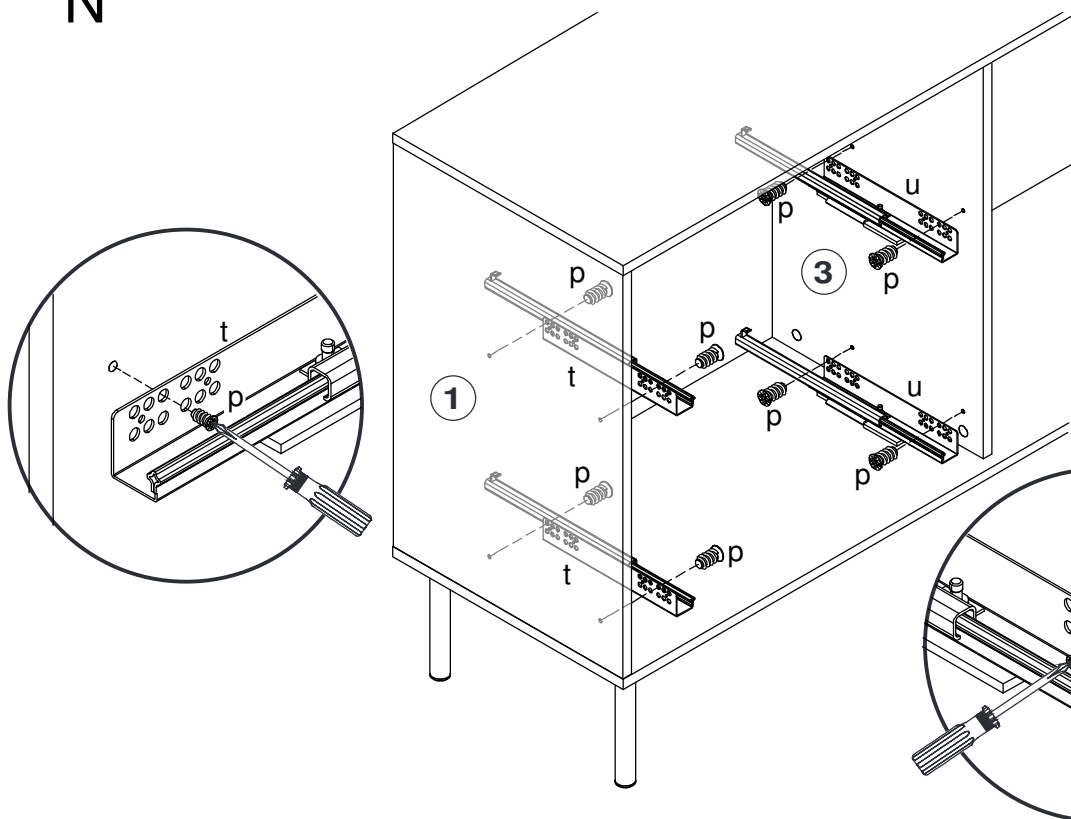

O

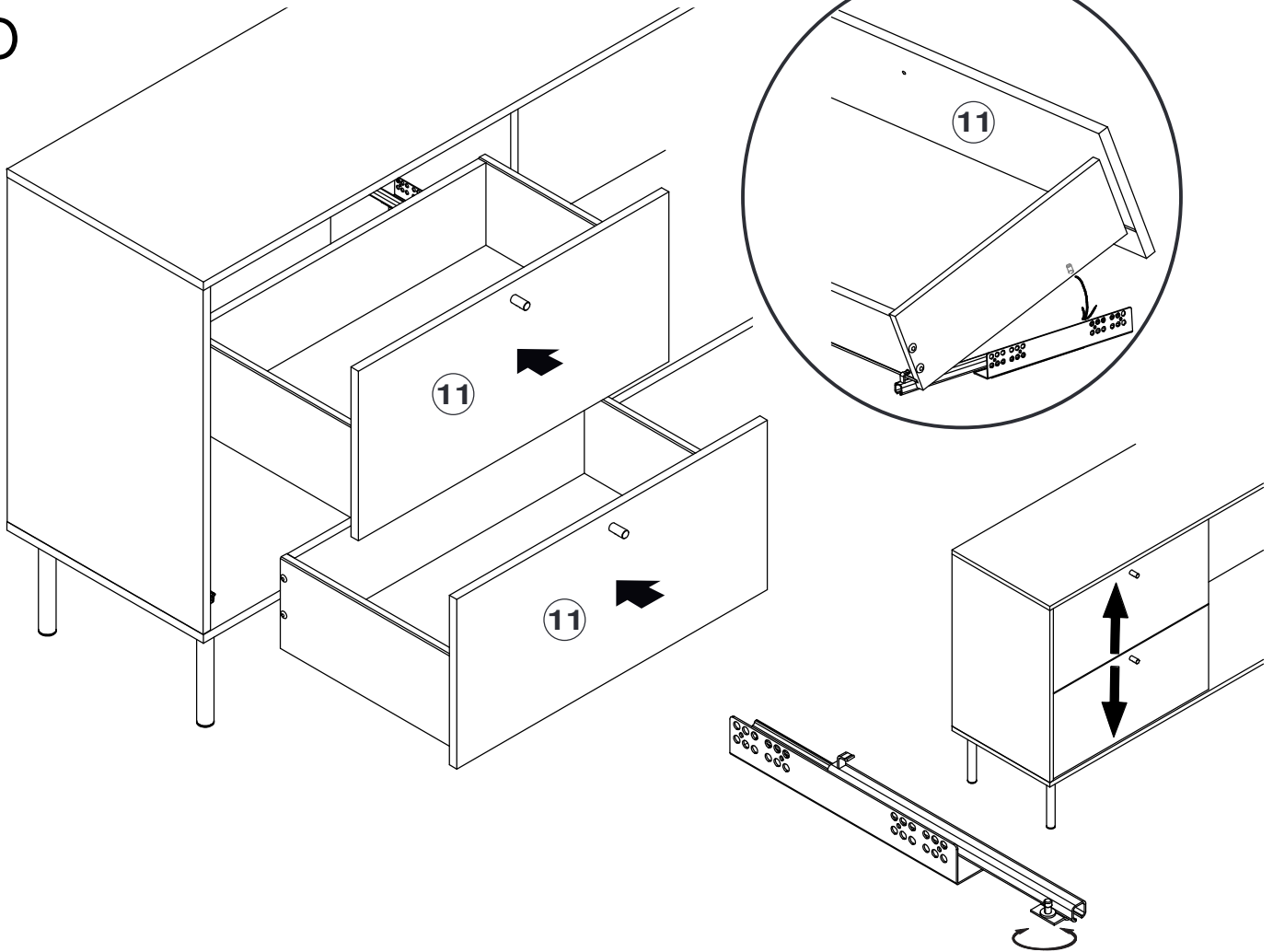

P

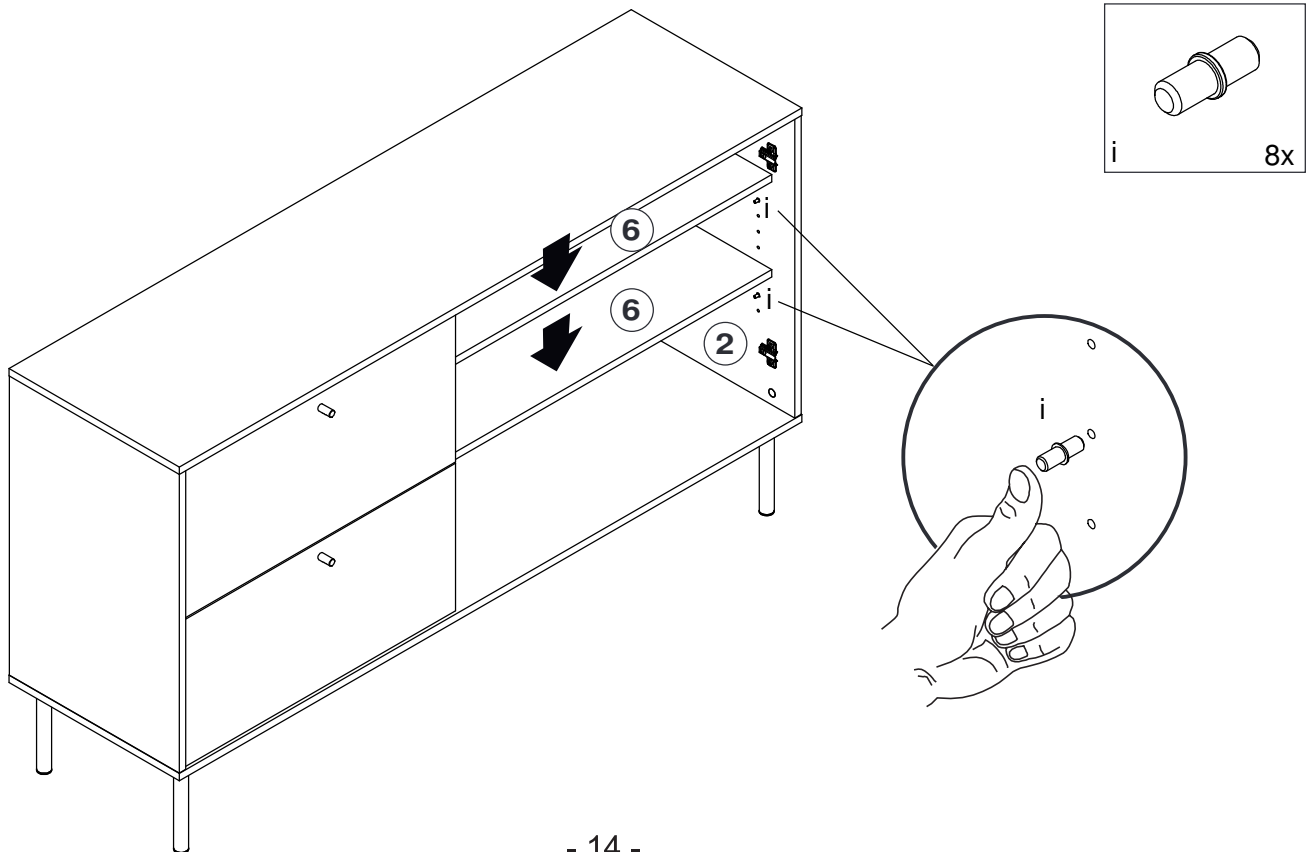

Q

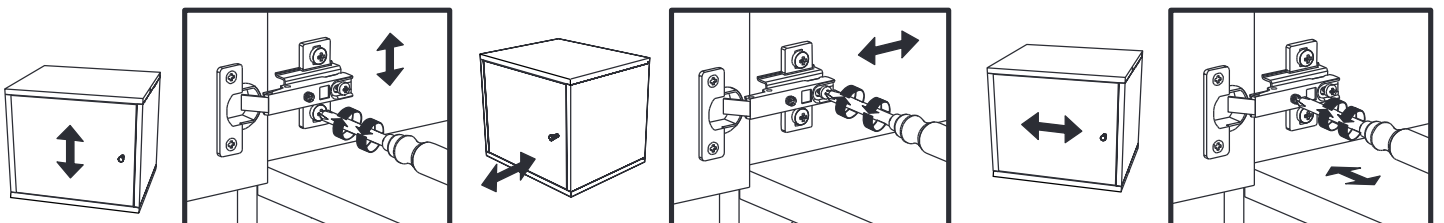
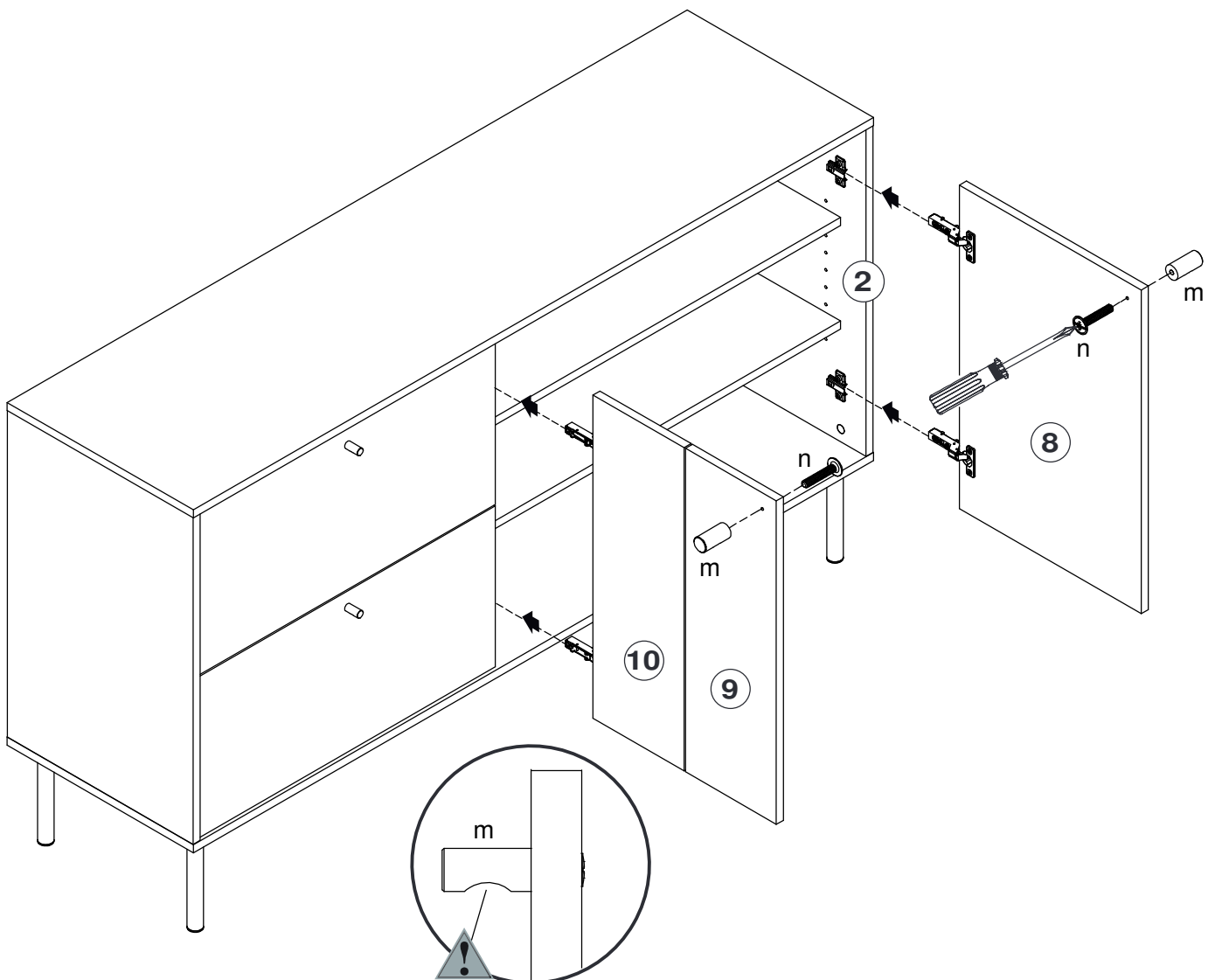
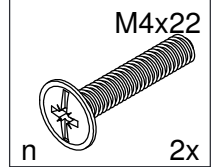
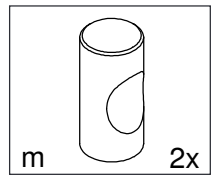
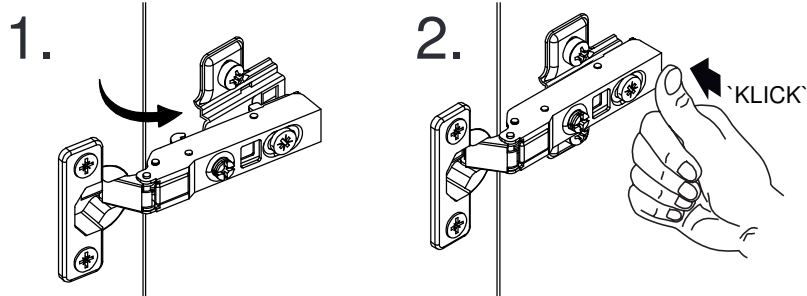



- Ⓐ Das Möbel muss an der Wand befestigt werden!
- Ⓑ Please ensure to mount the furniture to the wall!
- Ⓒ Les meubles doivent être fixés au mur!
- Ⓓ Het meubel moet aan de wand worden vastgemaakt!
- Ⓔ El mueble se tiene que fijar a la pared!
- Ⓕ Mebel należy przymocować do ściany!



- Ⓐ Informieren Sie sich vor der Wandmontage über das geeignete Montagematerial!
- Ⓑ Please get informed on suitable assembly materials before commencing the wall-mounting!
- Ⓒ Renseignez-vous sur le matériel de montage approprié avant le montage mural!
- Ⓓ Informeer u voor de wandmontage over het geschikte montagematerieel!
- Ⓔ Infórmese antes del montaje en la pared del material apropiado de montaje!
- Ⓕ Przed montażem na ścianie upewnij się, jaki jest potrzebny właściwy materiał montażowy!



- Ⓐ Beschaffen Sie sich das angemessene Material zur Wandbefestigung!
- Ⓑ Please obtain suitable wall-mounting materials!
- Ⓒ Procurez-vous le matériel approprié pour le montage mural!
- Ⓓ Verschaf u het adequate materieel voor de wandbevestiging!
- Ⓔ Procúrese el material adecuado para la fijación a la pared!
- Ⓕ Zakup odpowiedni materiał do przymocowania na ścianie!



- Ⓐ Lassen Sie die Wandbefestigung von einer fachkundigen Person vornehmen!
- Ⓑ Ensure all wall-mounting is carried out by competent personnel!
- Ⓒ Faites effectuer le montage mural par une personne compétente!
- Ⓓ Laat de wandbevestiging door een professional uitvoeren!
- Ⓔ Deje que la fijación a la pared la haga un profesional!
- Ⓕ Zlec przymocowanie do ściany odpowiednio doświadczonej osobie!

- Ⓐ Мебель должна крепиться к стене!
- Ⓑ Il mobile deve essere fissato alla parete!
- Ⓒ A bútor a falon rögzítendő!
- Ⓓ O móvel tem que ser fixado na parede!
- Ⓔ Nábytek musí být připevněn ke stěně!

- Ⓐ Перед тем, как крепить мебель к стене, получите информацию о подходящем крепежном материале!
- Ⓑ Prima del fissaggio alla parete, informarsi sul materiale di montaggio adatto!
- Ⓒ A bútor falra szerelés előtt tájékozódjon, hogy ehhez milyen szerelőanyagok szükségesek!
- Ⓓ Antes da montagem na parede, informe-se sobre o material de montagem adequado!
- Ⓔ Informujte se o vhodném montážním materiálu před montáží na stěnu!

- Ⓐ Приобретите соответствующий материал для крепления к стене!
- Ⓑ Procurarsi il materiale opportuno per il fissaggio alla parete!
- Ⓒ Szerezze be a falra szereléshez szükséges, megfelelő anyagokat!
- Ⓓ Obtenha o material adequado para a montagem na parede!
- Ⓔ Opatřte si vhodný materiál pro montáž na stěnu!

- Ⓐ Поручите выполнение работ по креплению к стене специалисту!
- Ⓑ Far effettuare il fissaggio alla parete ad un esperto!
- Ⓒ A bútor falra rögzítését végeztesse ehhez értő személlyel!
- Ⓓ A montagem na parede deve ser executada por uma pessoa competente!
- Ⓔ Montáž na stěnu nechte provést odborně způsobilou osobou!

