

ASSEMBLY INSTRUCTIONS

OUTDOOR CORNER SOFA

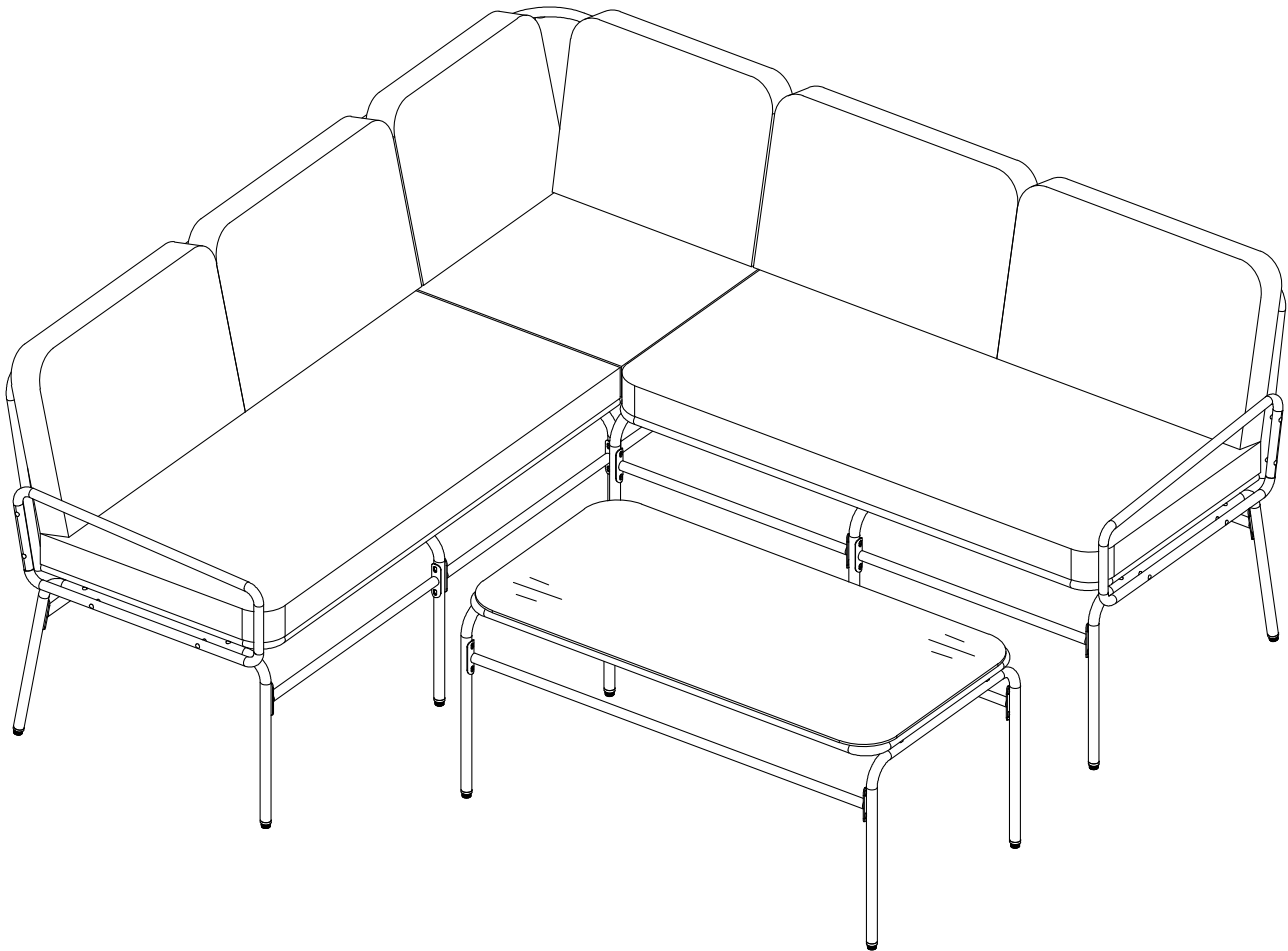

WF317139, WF317140

Before installation, insert the screws into the holes and tighten them, but do not tighten them to 100%, 70% to 80% is sufficient. Finally, after all screws are installed, tighten all screws to 100%. If you encounter these issues, such as if the holes cannot be aligned or some parts cannot be installed, please check if the screws are used correctly and adjust the tightness of the screws.

x1

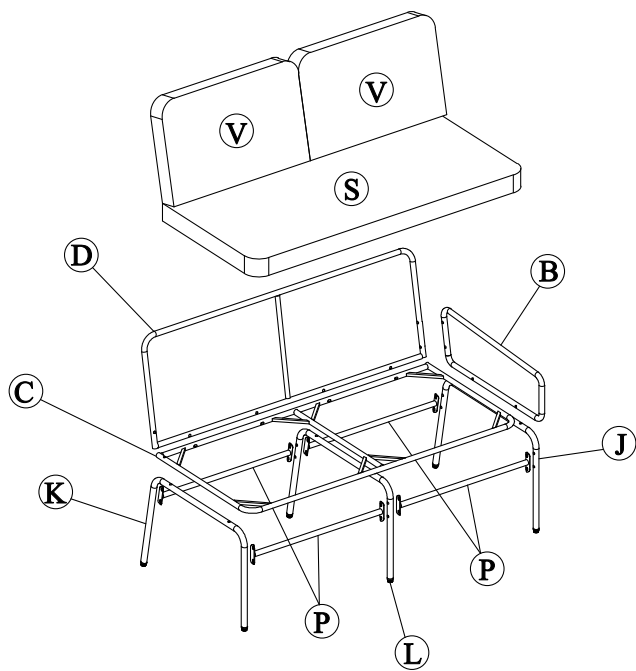

x1

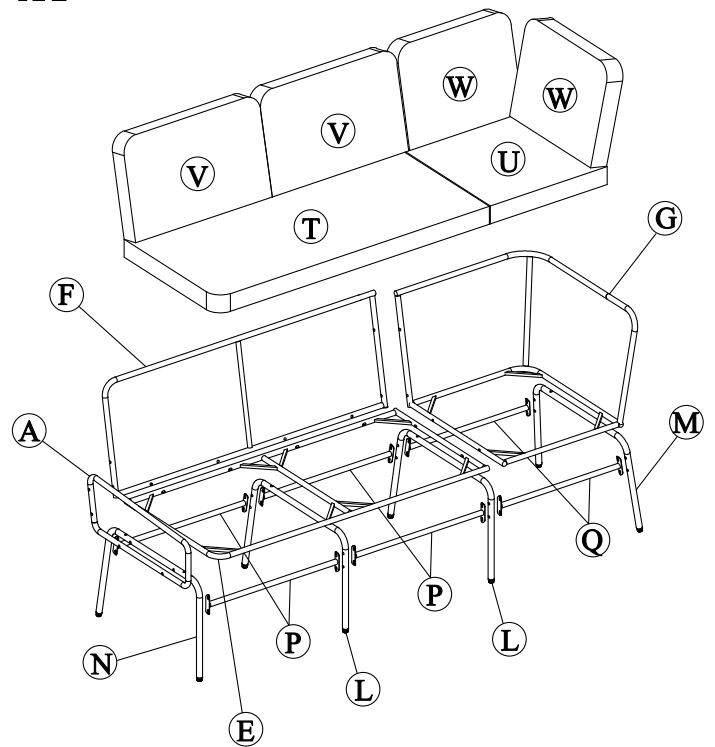

x1

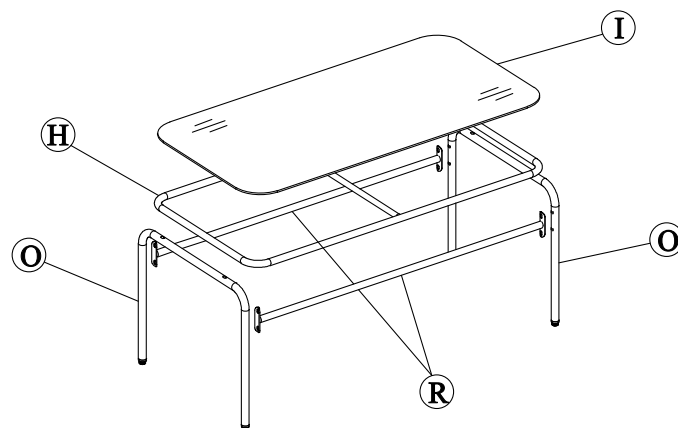

Notice:

1. 50% Tighten before fixing all screws, Allen wrench is recommended instead of an electric drill.
2. Place the item on a flat ground to adjust and make sure it remains stable
3. Tighten up all screws with tools gradually.
4. If the screws are not aligned with holes during assembly, please loosen all the other screws to 50% and continue the assembly process.
5. If the item is not stable, please loosen all the screws, adjust it on a flat ground and tighten up all screws again.
6. Note : If one or some screws are fully tightened during assembly, chances are the others will not be aligned with holes. In addition, all the holes are designed to be relatively larger to provide more space for the adjustment of the screws.

Part List:

A x1

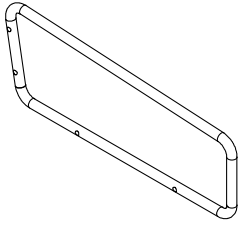

Arm Right Frame

B x1

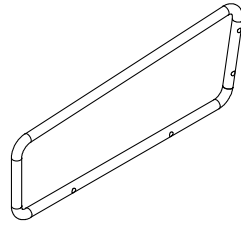

Arm Left Frame

C x1

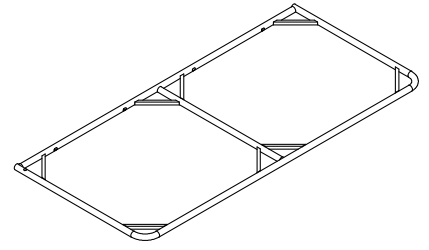

Seat Bench Frame

D x1

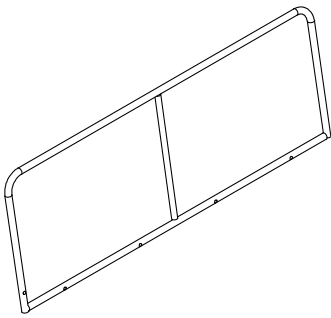

Back Bench Frame

E x1

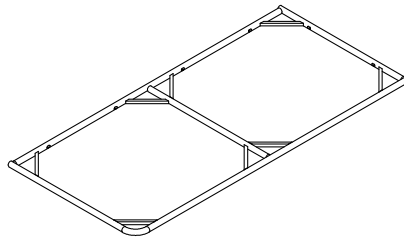

Seat Bench Frame

F x1

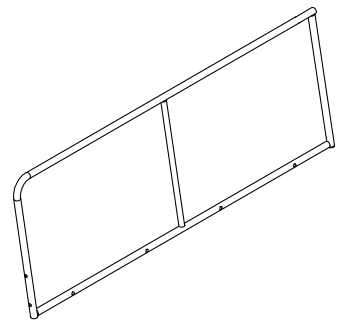

Back Bench Frame

G x1

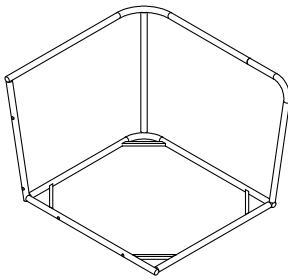

Bench Corner Frame

H x1

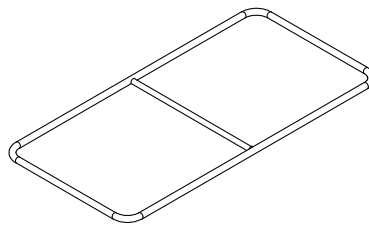

Table Top Frame

I x1

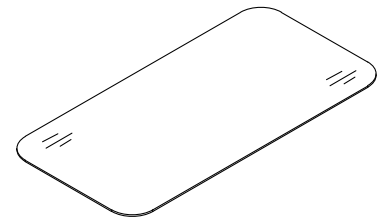
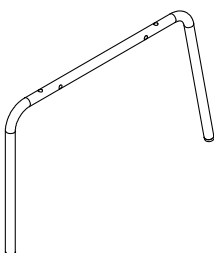

Table Glass

J x1



Leg Left Bench

K x1

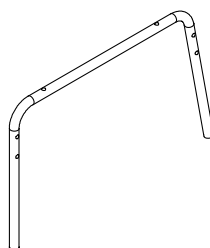

Leg Right Bench

L x3

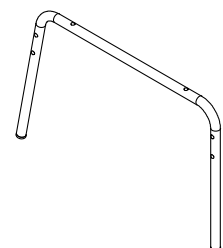

Leg Middle

Part List:

Ⓜ x1

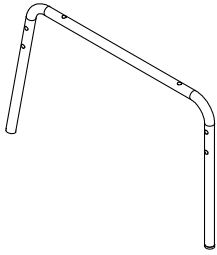

Leg Left Bench

Ⓝ x1

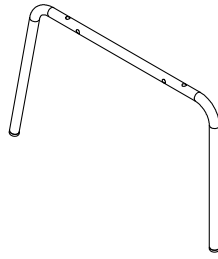

Leg Right Bench

Ⓞ x2

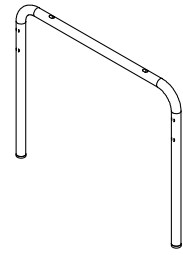

Leg Table

Ⓟ x8

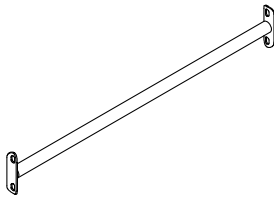

Stretcher

Ⓠ x2

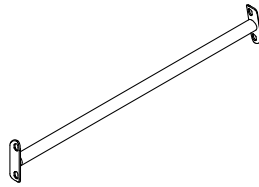

Stretcher

Ⓡ x2

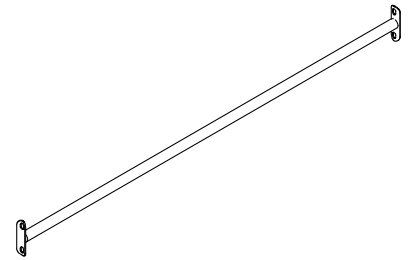

Stretcher

Ⓢ x1

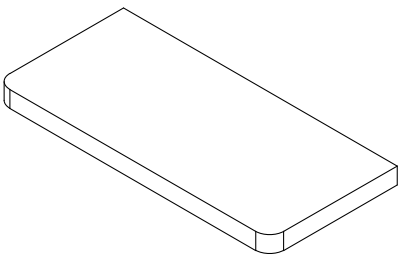

Bench Cushion

Ⓣ x1

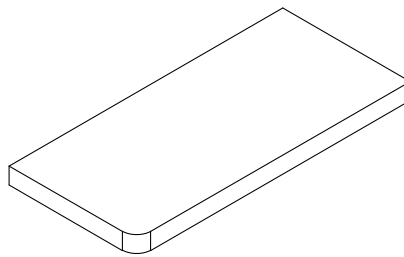

Bench Cushion

Ⓤ x1

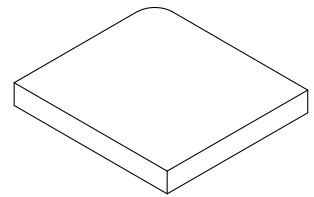

Corner Cushion

Ⓥ x4

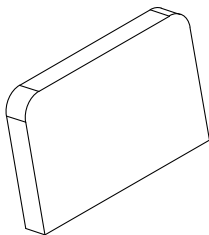

Big Back Pillow

Ⓦ x2

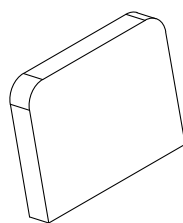

Small Back Pillow

Hardware List:

① x 8 pcs
Extra 1 pc

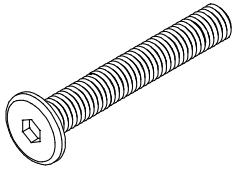

Bolt M6 x 60 mm

② x 30 pcs
Extra 3 pcs

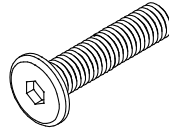

Bolt M6 x 40 mm

③ x 12 pcs
Extra 2 pcs

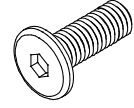

Bolt M6 x 20 mm

④ x 26 pcs
Extra 2 pcs

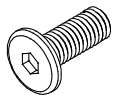

Bolt M6 x 15 mm

⑤ x 48 pcs
Extra 3 pcs



M6 x 1 mm Washers

⑥ x 8 pcs
Extra 1 pc



Eru M6

⑦ x 12 pcs
Extra 2 pcs

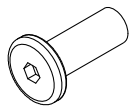

Hexagon nuts

⑧ x 18 pcs
Extra 2 pcs

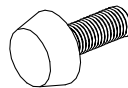

Feet cap M6 x 15 mm

⑨ x 1 pc

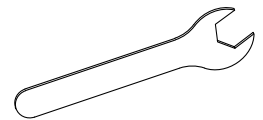

Spanner

⑩ x 2 pcs

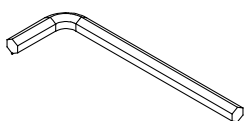

Allen key M4

⑪ x 1 pc

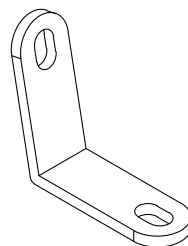

Keeper Plate

CARTON CONTENT:

WF317139

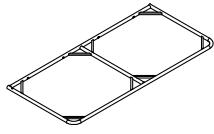

C x 1

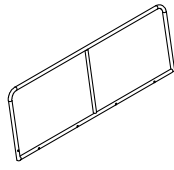

D x 1

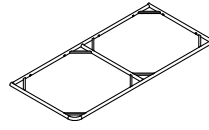

E x 1

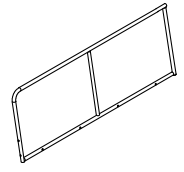

F x 1

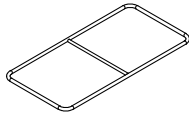

H x 1

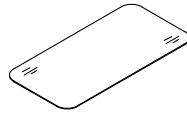

I x 1

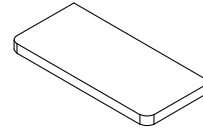

S x 1

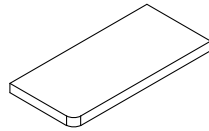

T x 1

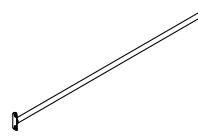

R x 2

WF317140

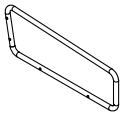

A x 1

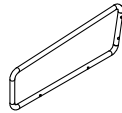

B x 1

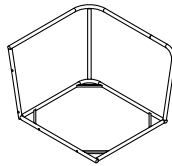

G x 1

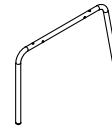

J x 1



K x 1

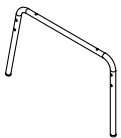

L x 3

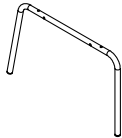

M x 1

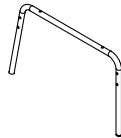

N x 1

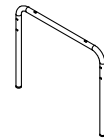

O x 2

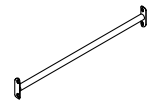

P x 8

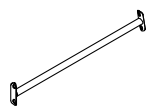

Q x 2

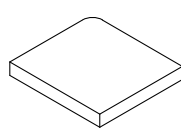

U x 1

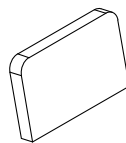

V x 4

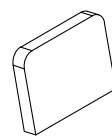

W x 2



HARDWARE

STEP 1

- ⓐ x 1
- ⓑ x 1
- ⓒ x 1
- ⓓ x 1
- ⓔ x 6
- ⓕ x 6

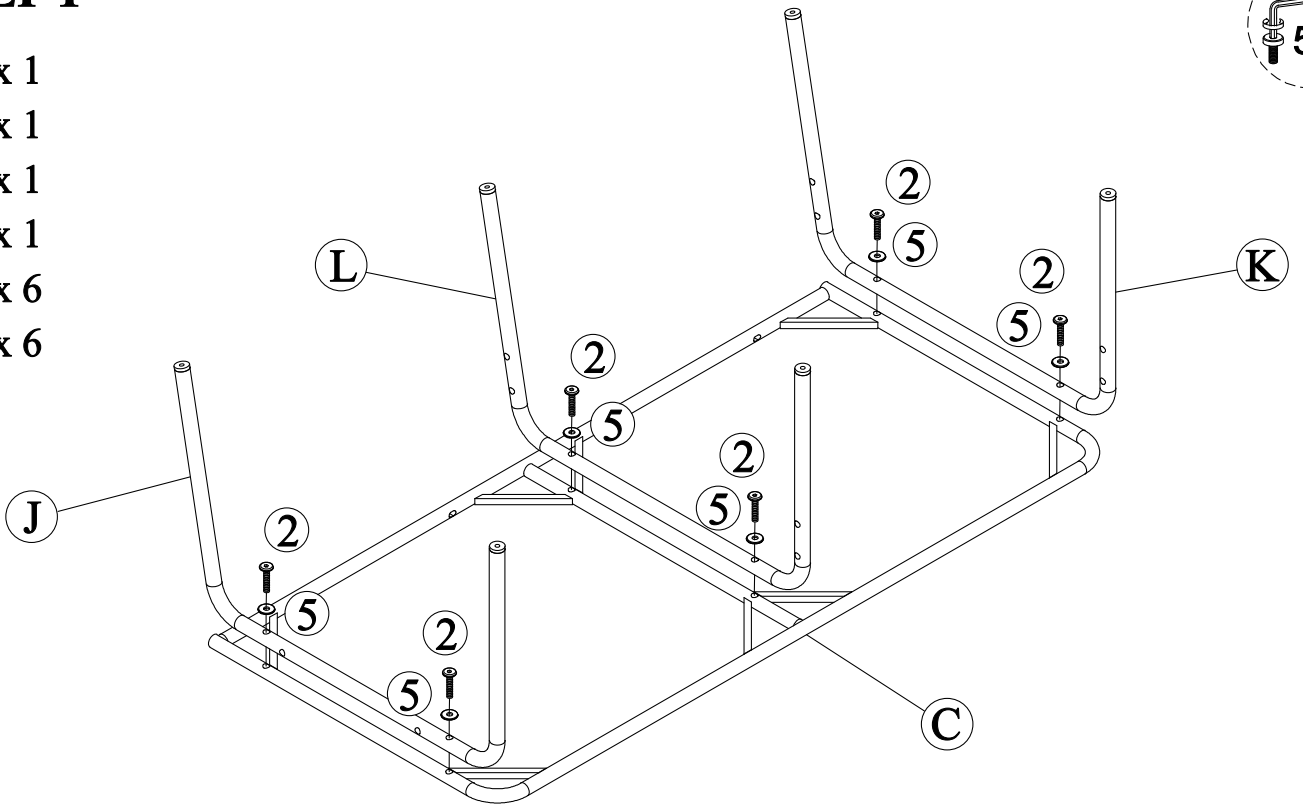

Connect Seat Bench Frame (C) & Leg Left Bench (J) & Leg Right Bench (K) & Leg Middle (L) with Bolt (2), Washers (5)

STEP 2

- ⓖ x 4
- ⓗ x 4
- ⓘ x 8
- ⓙ x 4

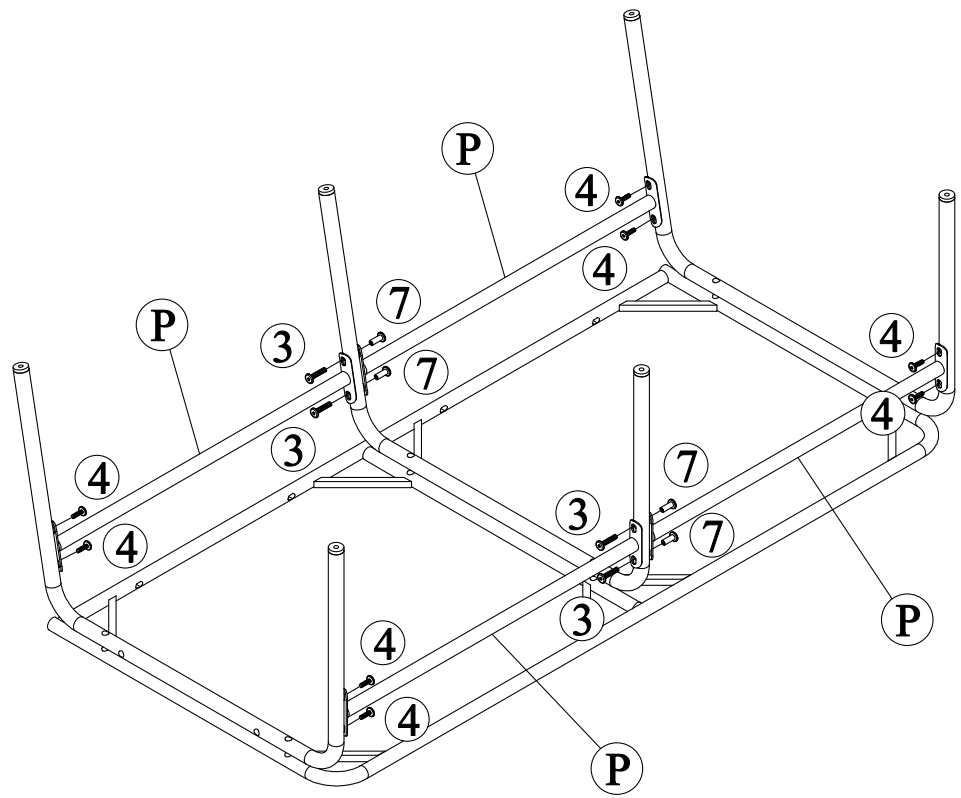

Connect part from Step 1 & Stretcher (P) with Bolt (3), (4) & Hexagon Nuts (7)

STEP 3

8 x 6

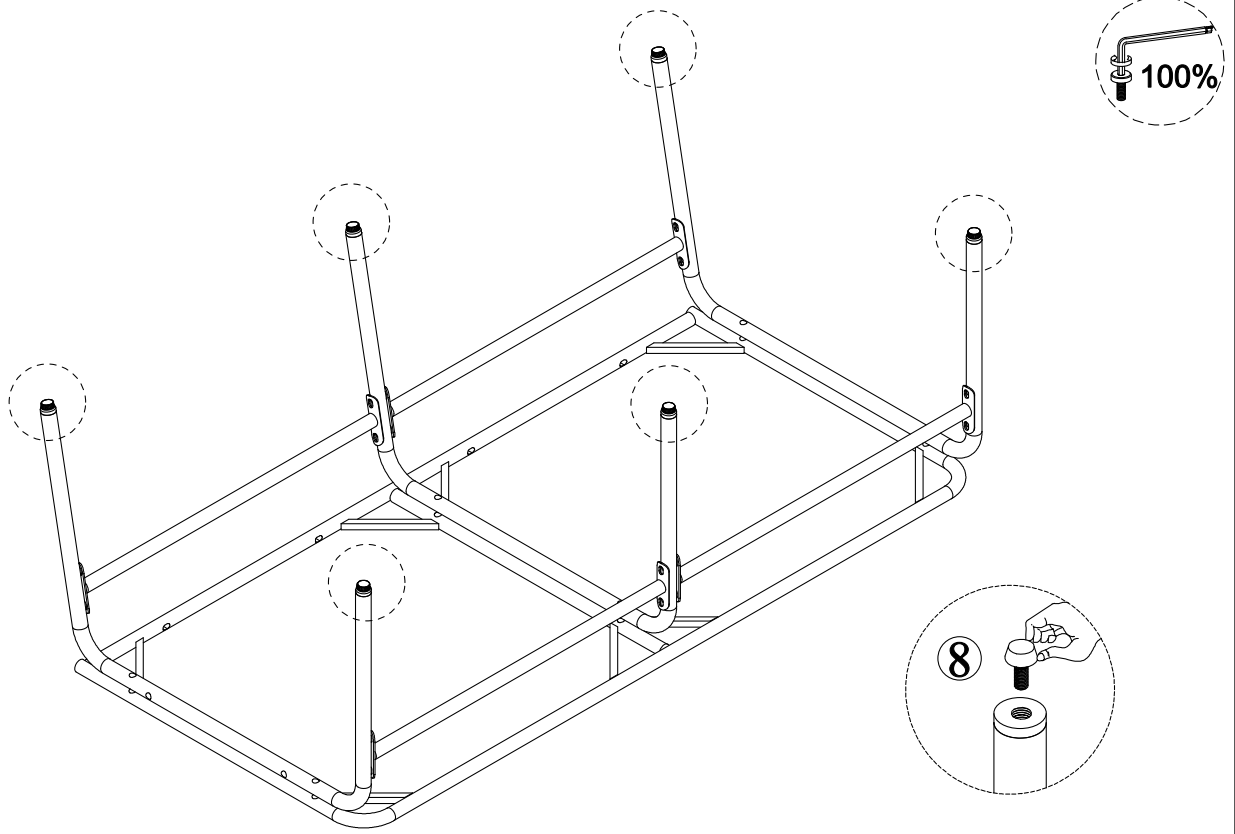

Connect part from Step 2 with Feet Cap (8)

STEP 4

D x 1
1 x 4
5 x 8
6 x 4

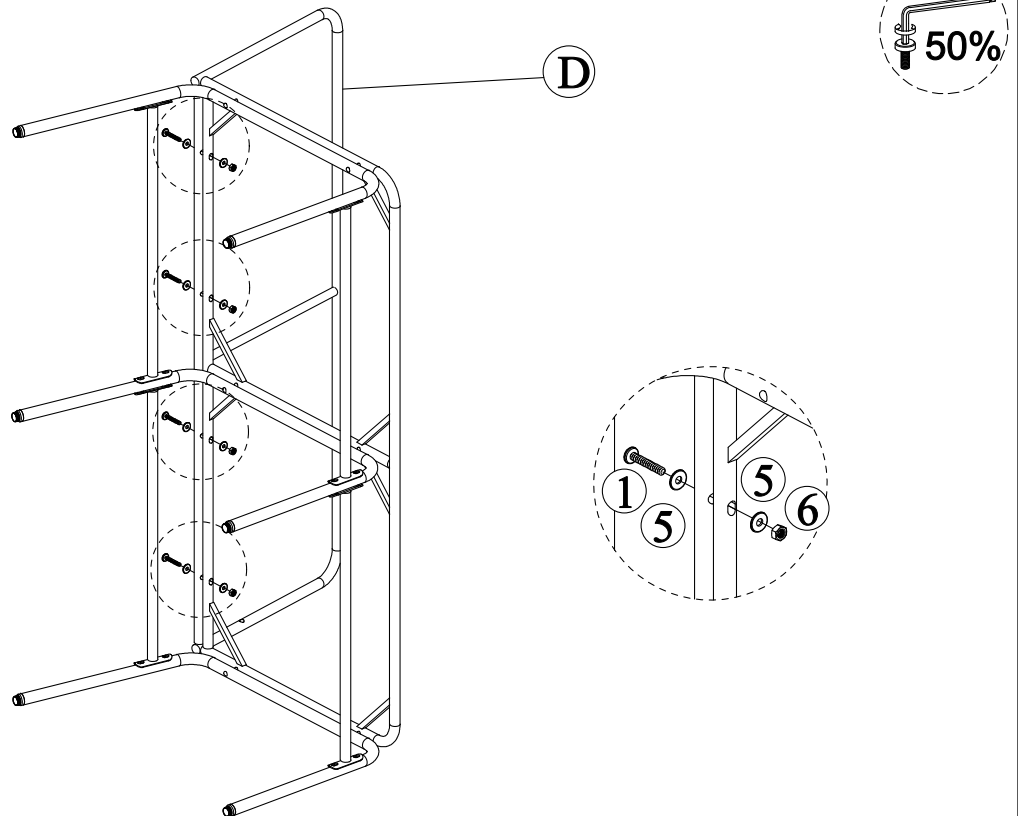

Connect part from Step 3 & Back Bench Frame (D) with Bolt (1), Washers (5) & Eruv (6)

STEP 5

- Ⓑ x 1
- ② x 4
- ⑤ x 4

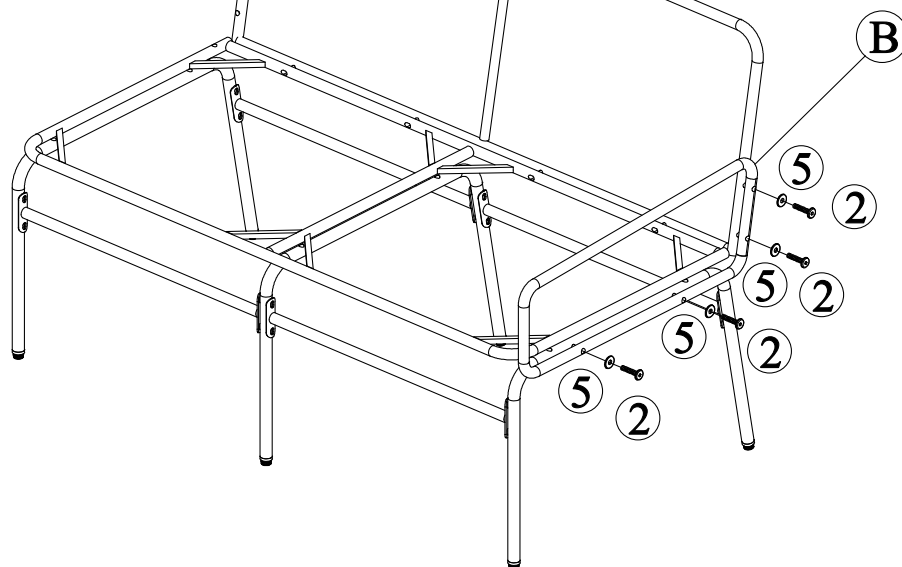

Connect part from Step 4 & Arm Left Frame (B) with Bolt (2), Washers (5)

STEP 6

- ④ x 2
- ⑤ x 2
- ⑪ x 1

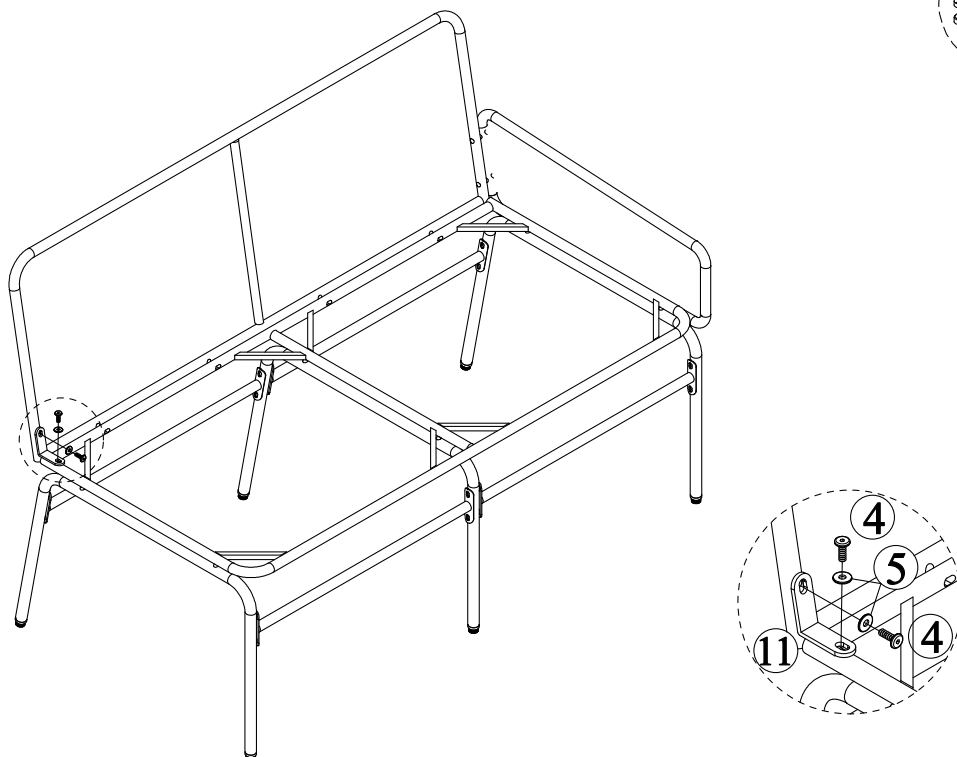

Connect part from Step 5 & Keeper Plate (11) with Bolt (4), Washers (5)

STEP 7

Ⓢ x 1

Ⓥ x 2

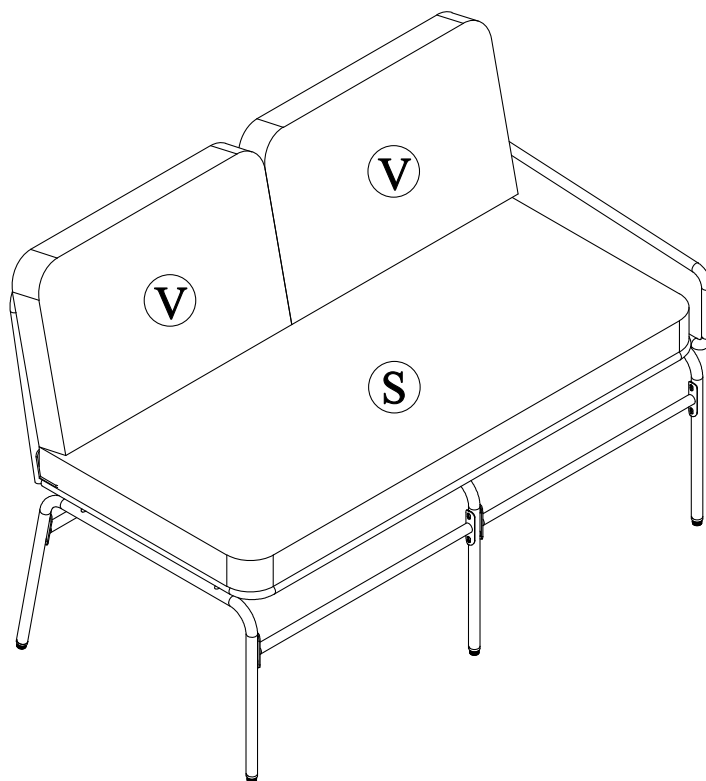

Put on Bench Cushion (S) & Big Back Pillow (V) to complete Bench

STEP 8

ⓔ x 1

ⓕ x 1

① x 4

⑤ x 8

⑥ x 4

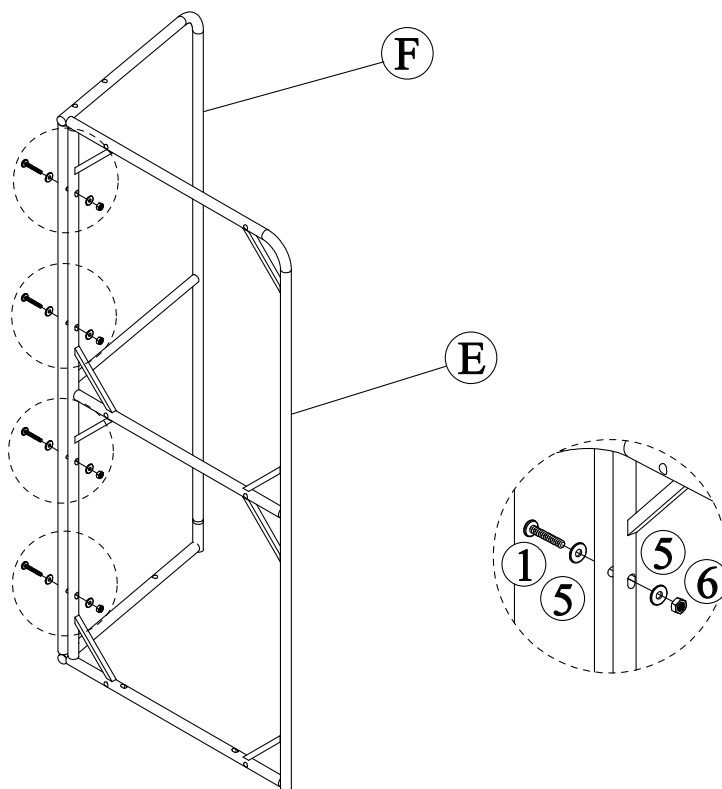

Connect Seat Bench Frame (E) & Back Bench Frame (F) with Bolt (1), Washers (5) & Nut (6)

STEP 9

- ⓐ x 1
- ⓑ x 2
- ⓓ x 2

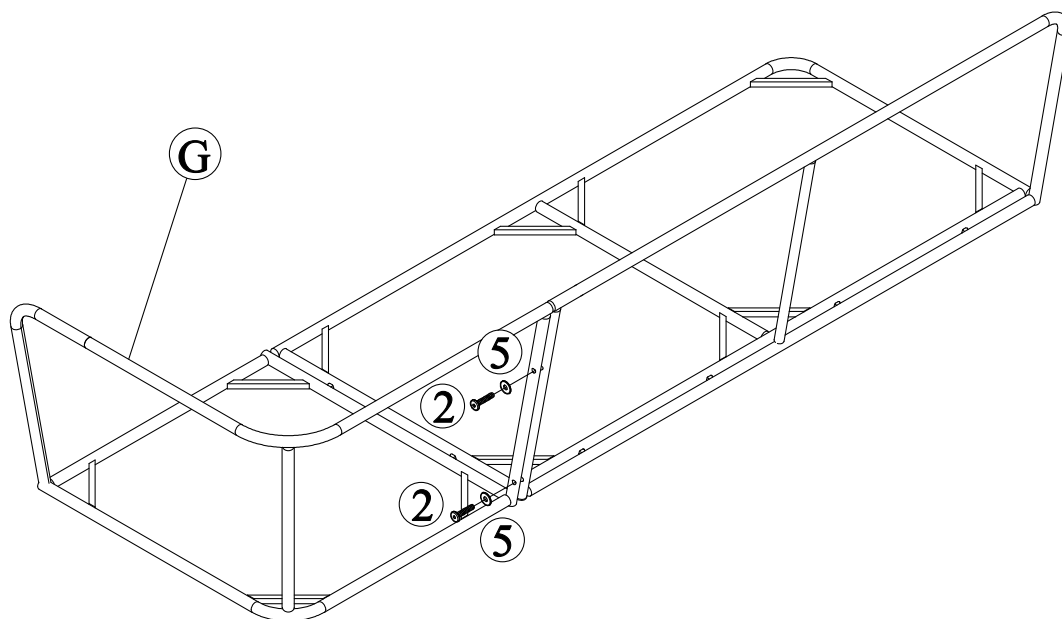

Connect part from Step 8 & Bench Corner Frame (G) with Bolt (2), Washers (5)

STEP 10

- ⓑ x 2
- ⓓ x 2

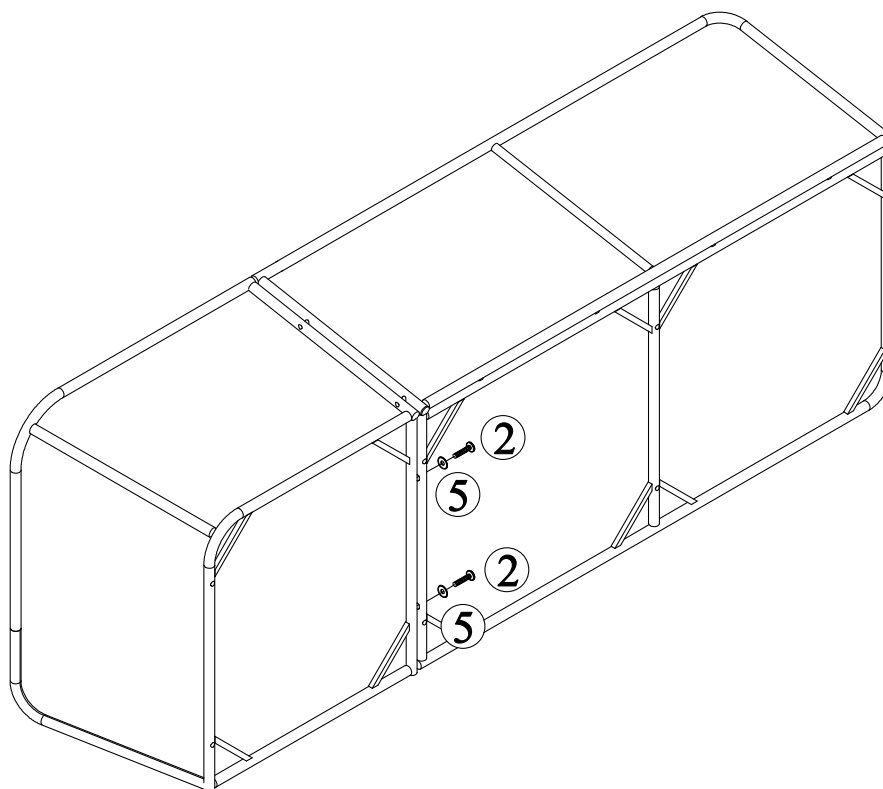

Connect part from Step 9 & Bench Corner Frame (G) with Bolt (2), Washers (5)

STEP 11

- Ⓛ x 2
- Ⓜ x 1
- Ⓝ x 1
- ② x 8
- ⑤ x 8

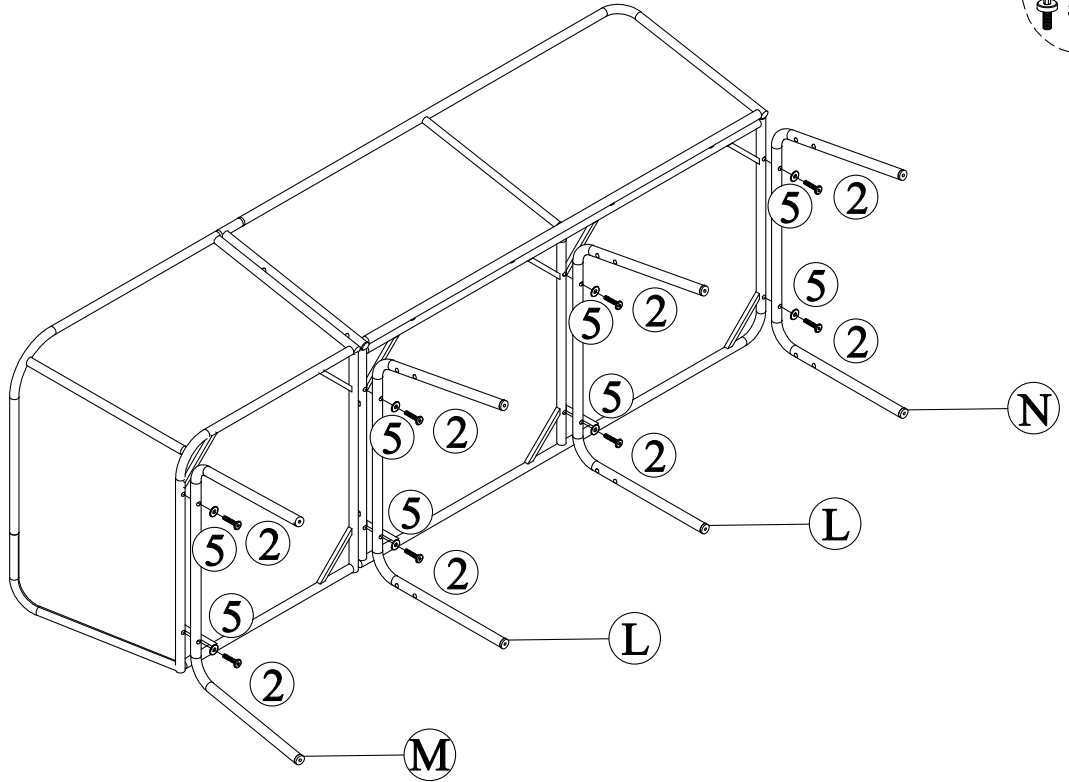
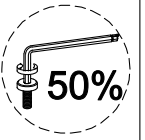

Connect part from Step 10 & Leg Left Bench (M) & Leg Right Bench (N) & Leg Middle (L) with Bolt (2) & Washers (5)

STEP 12

- Ⓟ x 4
- Ⓠ x 2
- ③ x 8
- ④ x 8
- ⑦ x 8

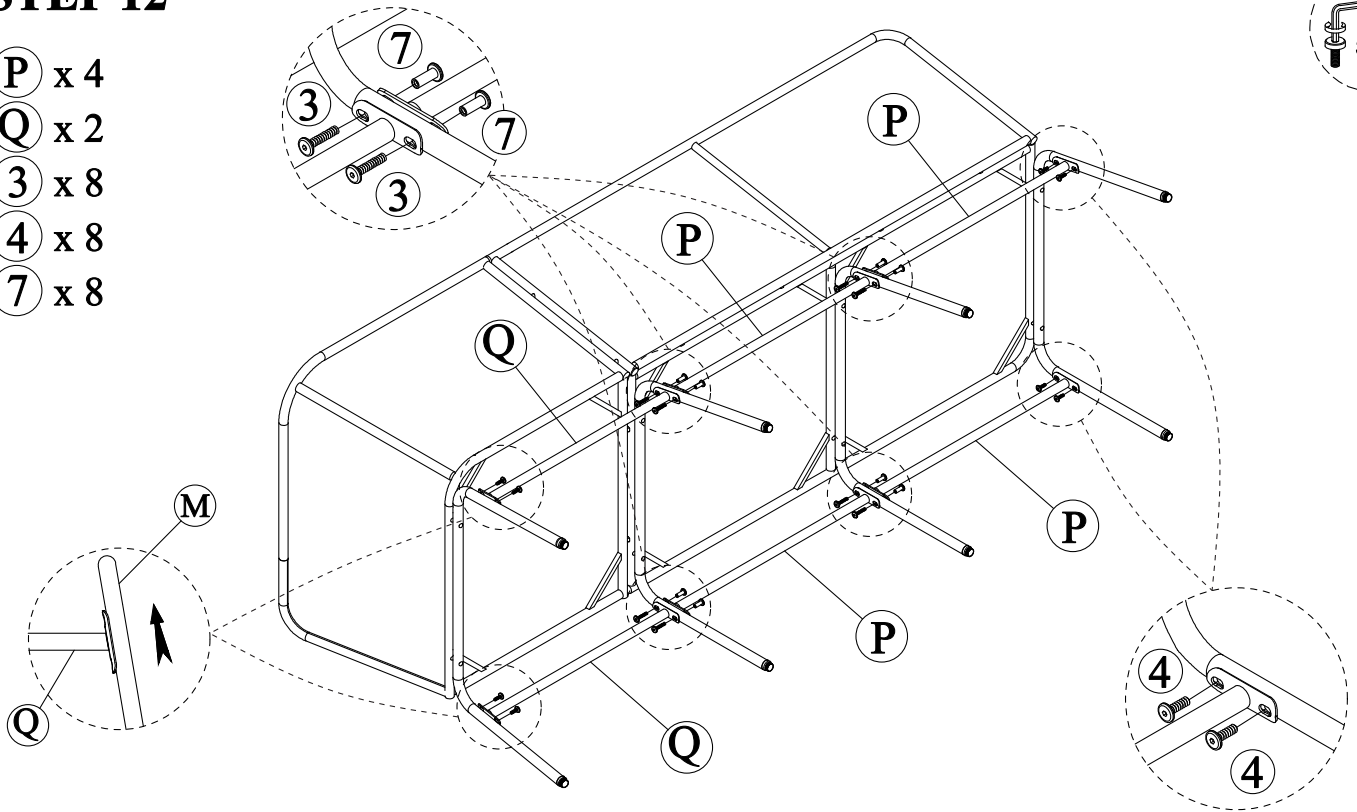
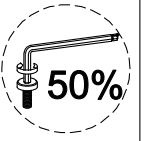

Connect part from Step 11 & Stretcher (P) & Stretcher (Q) with Bolt (3), (4) & Hexagon Nuts (7)

STEP 13

8 x 8

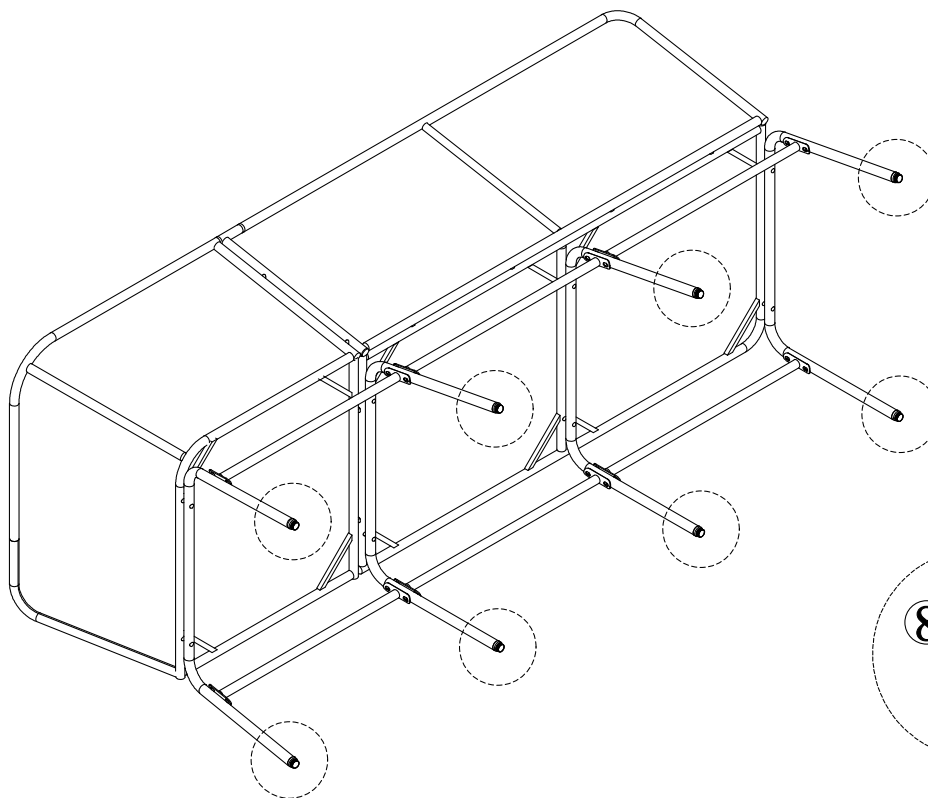

Connect part from Step 12 with Feet Cap (8)

STEP 14

A x 1

2 x 4

5 x 4

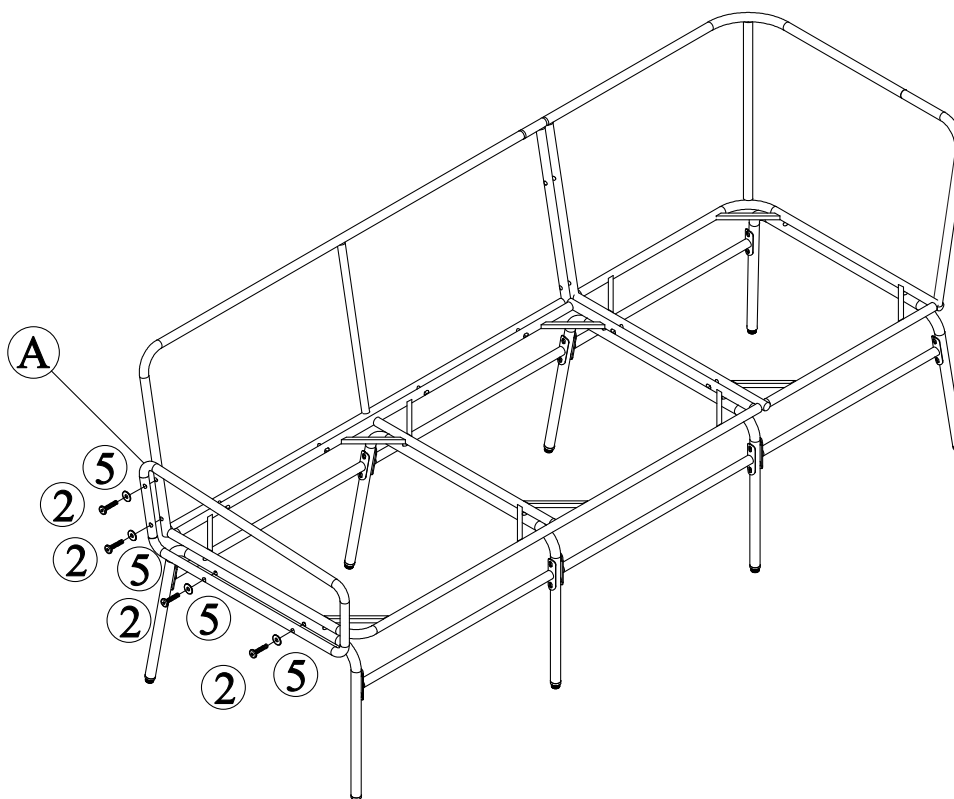

Connect part from Step 13 & Arm Right Frame (A) with Bolt (2) & Washers (5)

STEP 15

- Ⓣ x 1
- Ⓤ x 1
- Ⓥ x 2
- Ⓦ x 2

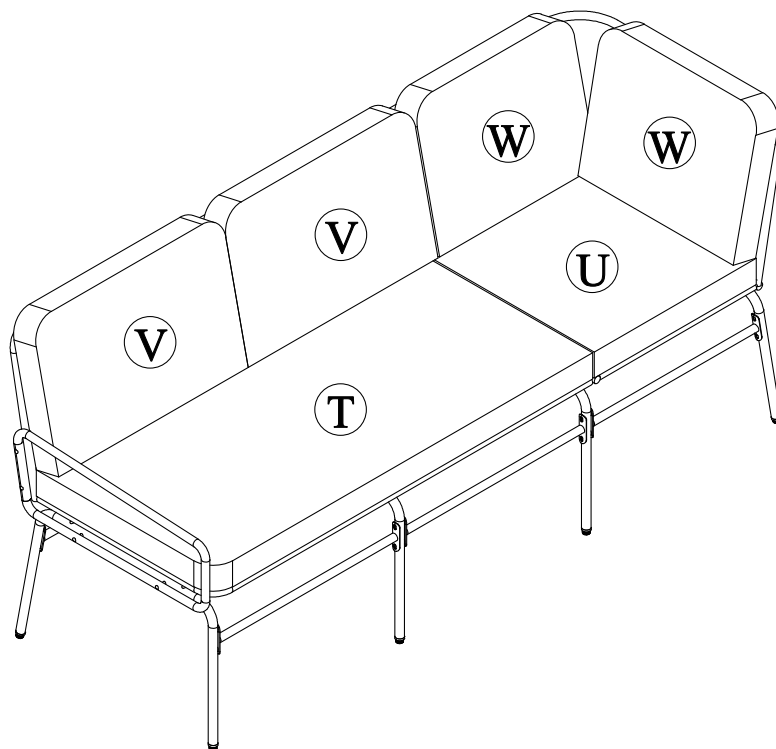

Put on Bench Cushion (T) & Corner Cushion (U) & Big Back Pillow (V) & Small Back Pillow (W) to complete Corner Bench

STEP 16

- ⓓ x 1
- ⓐ x 2
- ⓑ x 4
- ⓔ x 4

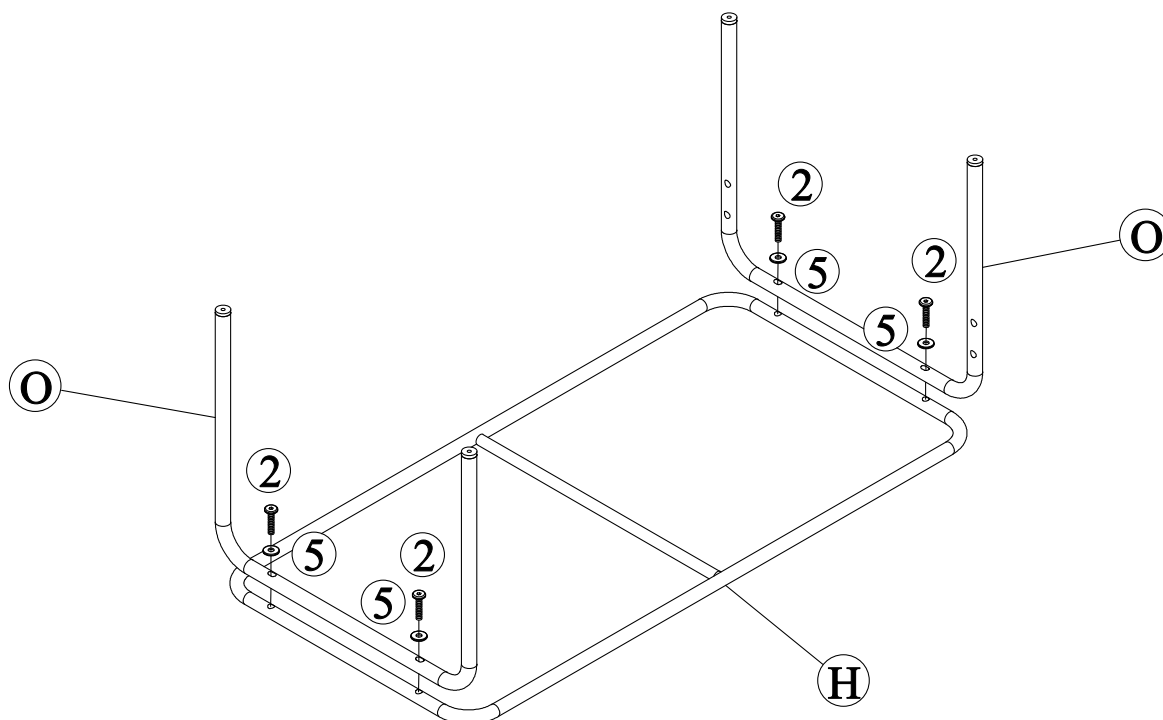

Connect Table Top Frame (H) & Leg Table (O) with Bolt (2), Washers (5)

STEP 17

Ⓡ x 2

④ x 8

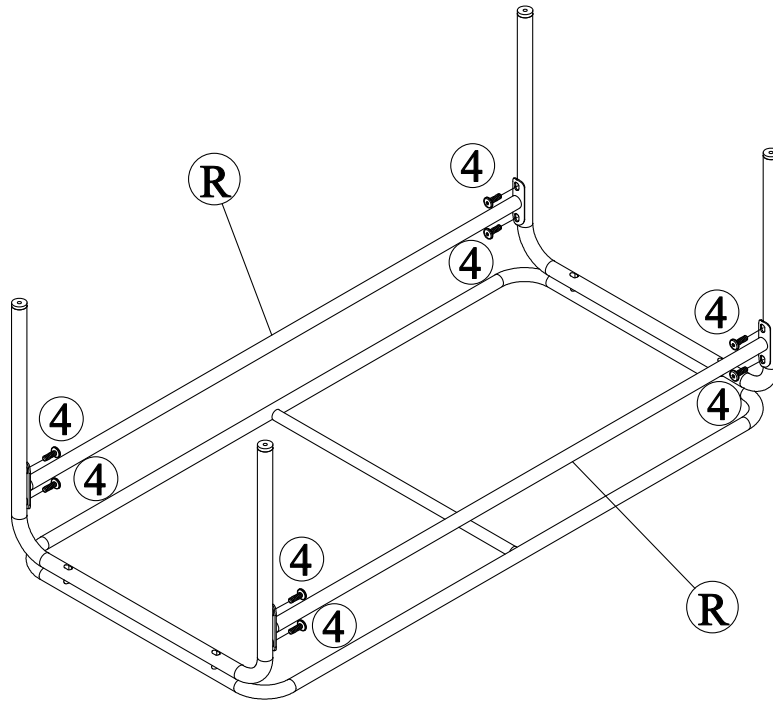

Connect part from Step 16 & Stretcher (R) with Bolt (4)

STEP 18

⑧ x 4

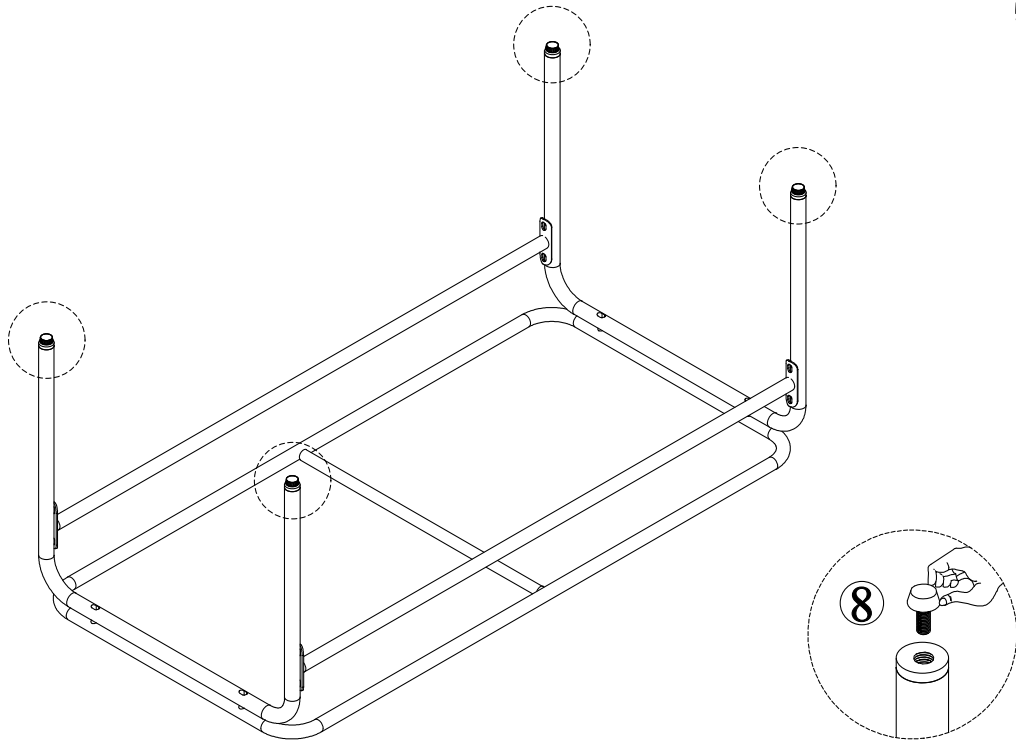

Connect part from Step 17 with Feet Cap (8)

STEP 19

Ⓘ x 1

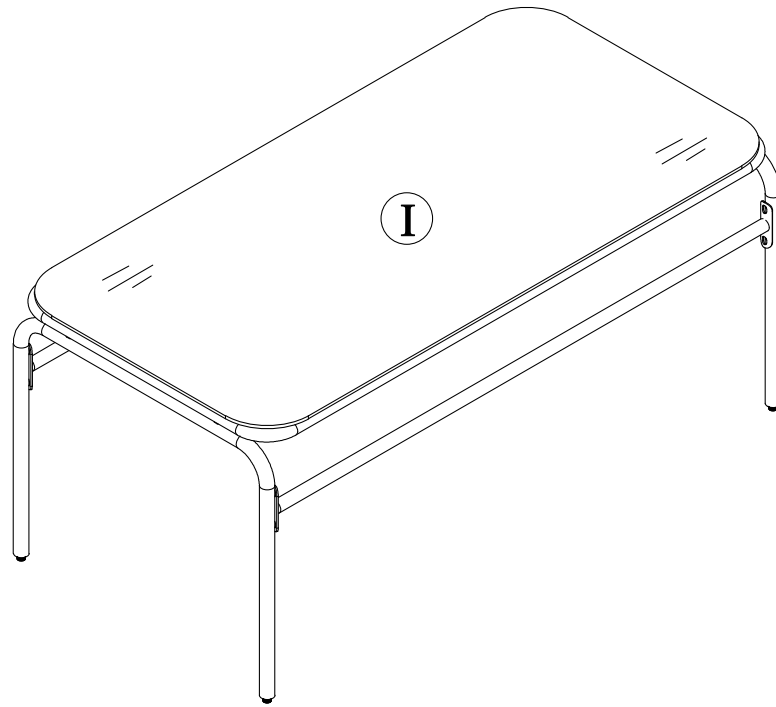

Put on Table Glass (I) to complete Table

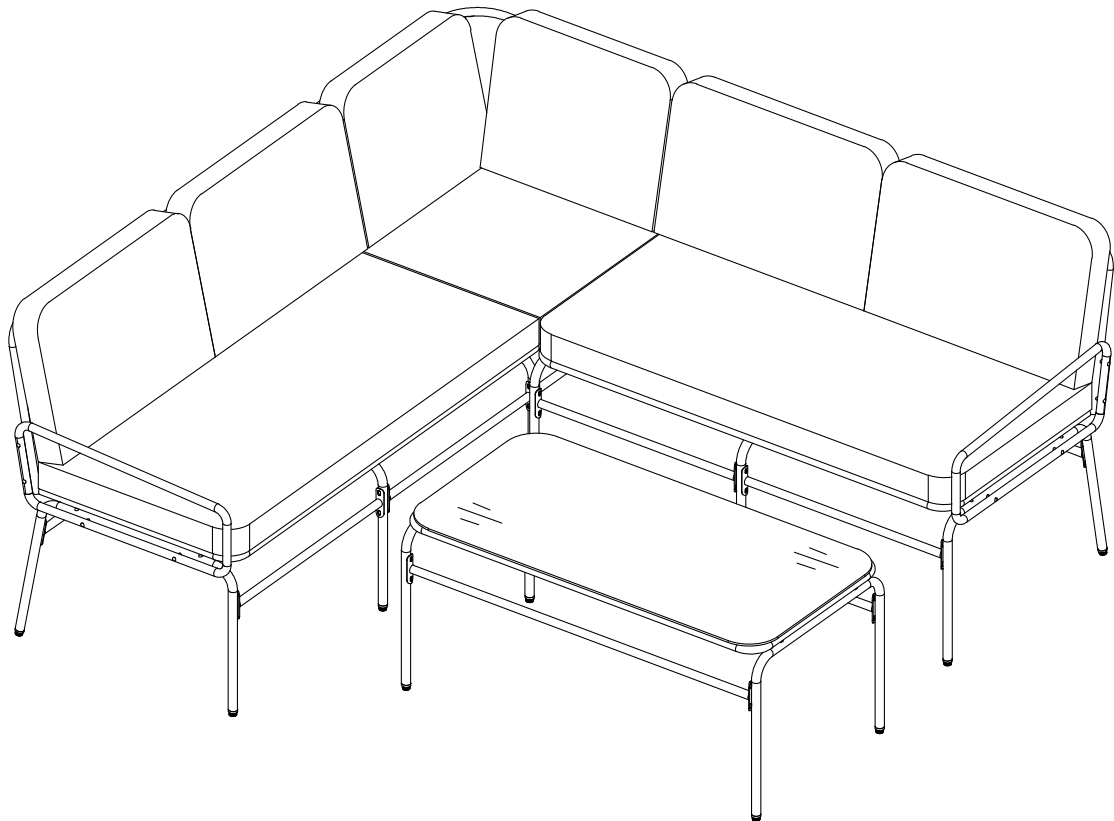

Finish Sofa

INSTALLATIONSANWEISUNG

OUTDOOR CORNER SOFA

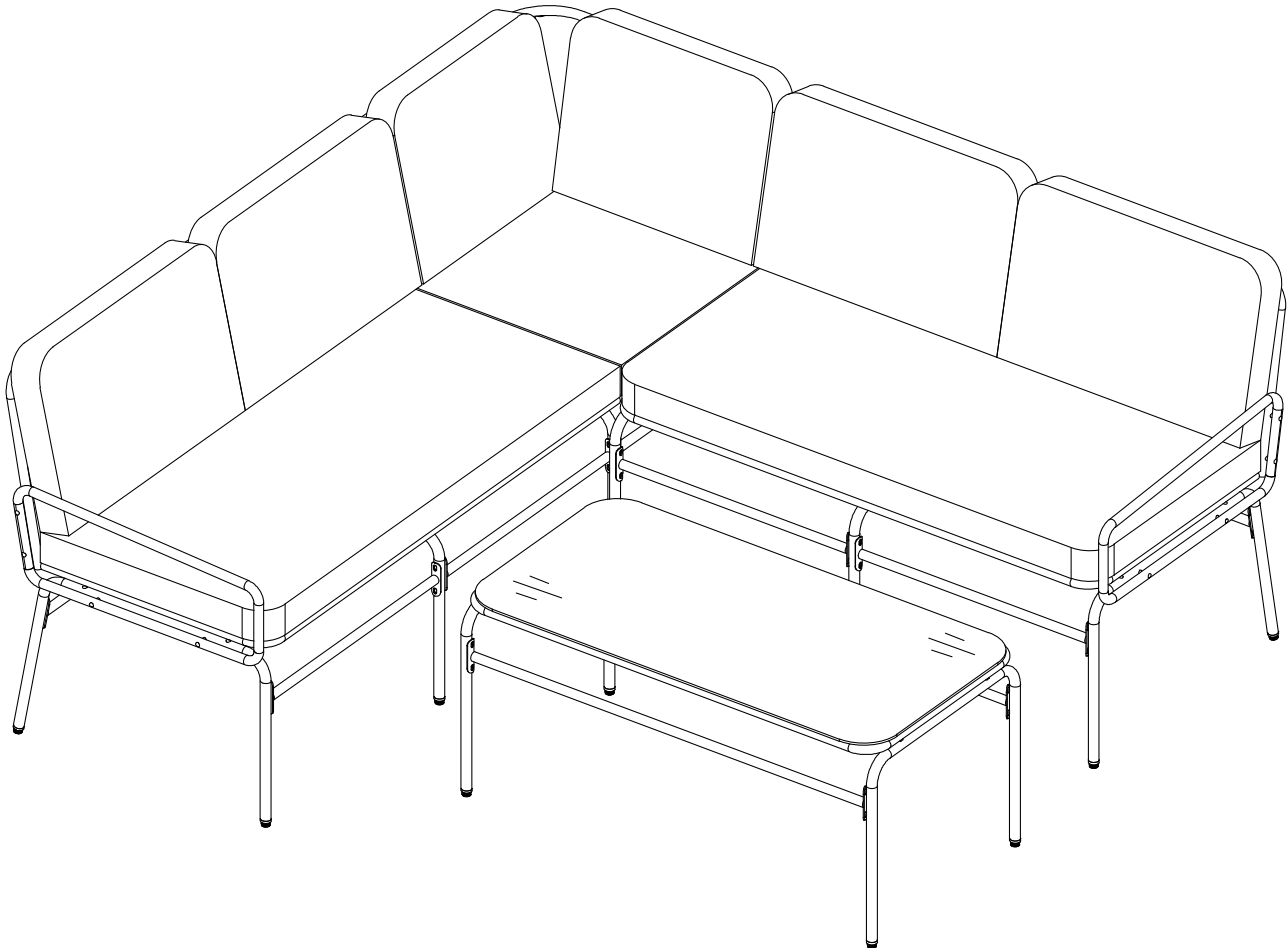

WF317139, WF317140

Setzen Sie vor der Installation die Schrauben in die Löcher ein und ziehen Sie sie fest, aber ziehen Sie sie nicht zu 100 % an, 70 % bis 80 % reichen aus. Schließlich, nachdem alle Schrauben installiert sind, ziehen Sie alle Schrauben zu 100 % an. Wenn Sie auf diese Probleme stoßen Wenn beispielsweise die Löcher nicht ausgerichtet werden können oder einige Teile nicht installiert werden können, überprüfen Sie bitte, ob die Schrauben richtig verwendet werden, und passen Sie den festen Sitz der Schrauben an.

x1

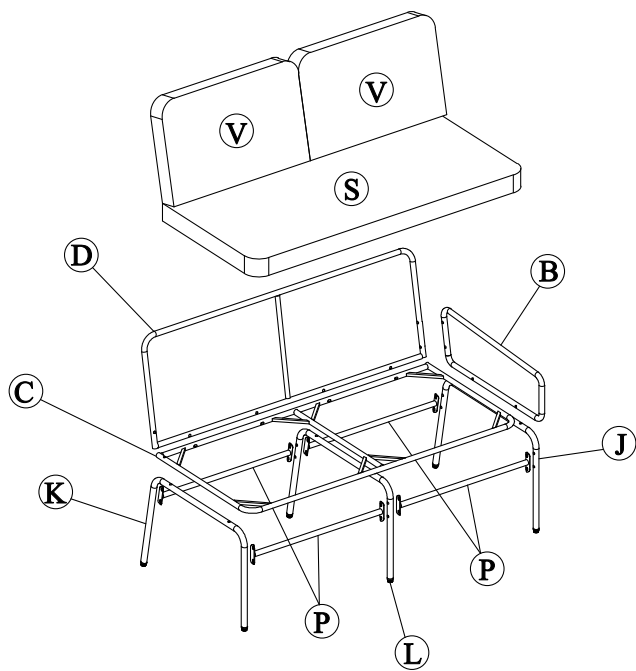

x1

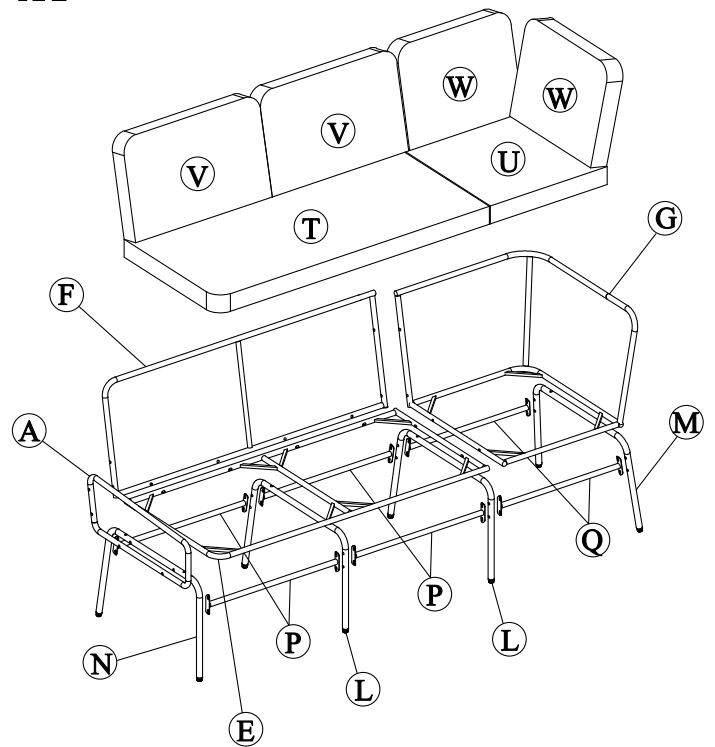

x1

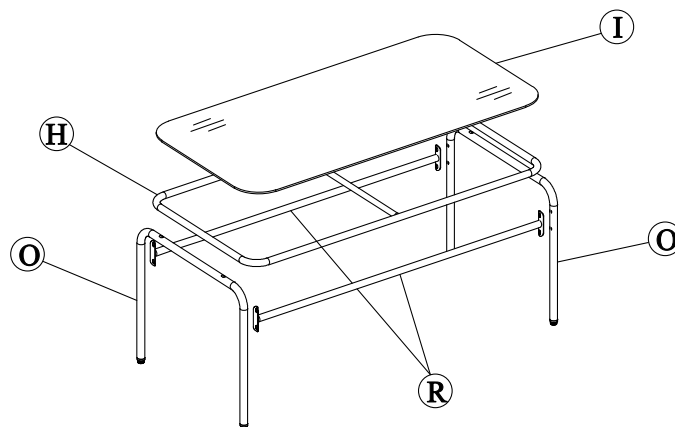

Beachten:

1. 50 % festziehen, bevor alle Schrauben befestigt werden. Anstelle einer elektrischen Bohrmaschine wird ein Inbusschlüssel empfohlen.
2. Stellen Sie den Gegenstand zum Ausrichten auf einen ebenen Untergrund und stellen Sie sicher, dass er stabil bleibt.
3. Alle Schrauben mit Werkzeug nach und nach festziehen.
4. Wenn die Schrauben bei der Montage nicht mit den Löchern übereinstimmen, lösen Sie bitte alle! Drehen Sie die anderen Schrauben auf 50 % und setzen Sie den Montagevorgang fort.
5. Sollte der Artikel nicht stabil stehen, lösen Sie bitte alle Schrauben, stellen Sie ihn auf einen ebenen Untergrund und ziehen Sie alle Schrauben wieder fest.
6. Hinweis: Wenn eine oder mehrere Schrauben während der Montage vollständig angezogen werden, besteht die Möglichkeit, dass die anderen nicht mit den Löchern ausgerichtet sind. Darüber hinaus sind alle Löcher relativ größer ausgelegt, um mehr Platz für die Justierung der Schrauben zu bieten.

Teileliste Liste:

Ⓐ x1

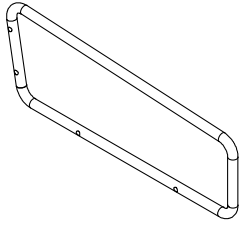

Arm rechter Rahmen

Ⓑ x1

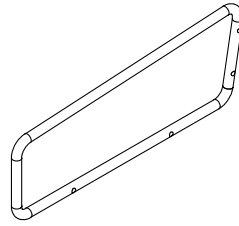

Arm linker Rahmen

Ⓒ x1

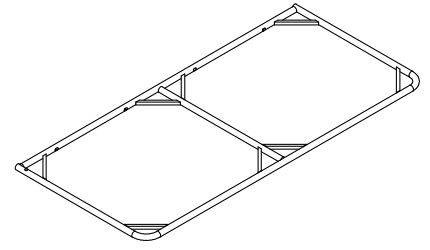

Sitzbankgestell

Ⓓ x1

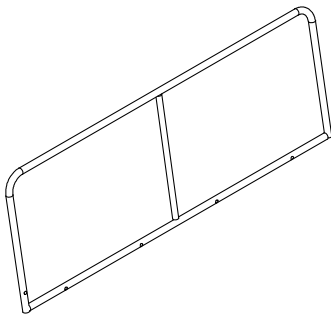

Rückbankrahmen

Ⓔ x1

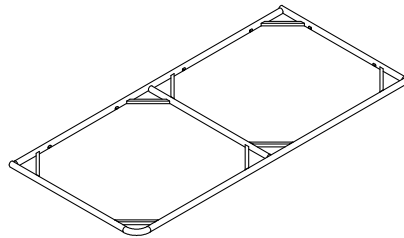

Sitzbankgestell

Ⓕ x1

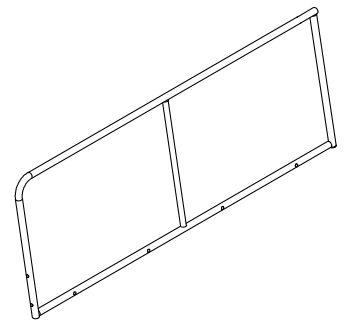

Rückbankrahmen

Ⓖ x1

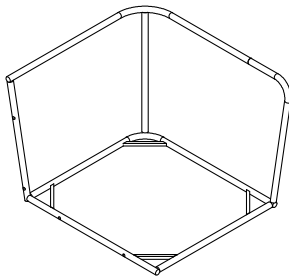

Bank-Eckrahmen

Ⓗ x1

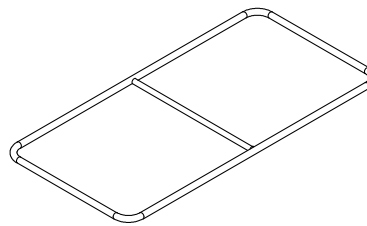

Tischplattengestell

Ⓘ x1

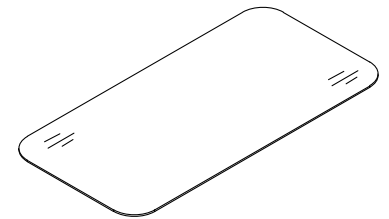

Tischglas

Ⓙ x1

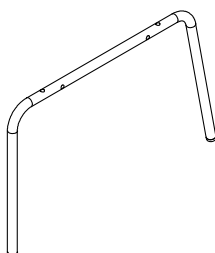

Bein linke Bank

Ⓚ x1

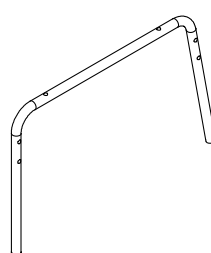

Beinrechte Bank

Ⓛ x3

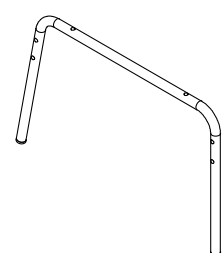

Beinmitte

Teileliste Liste:

Ⓜ x1

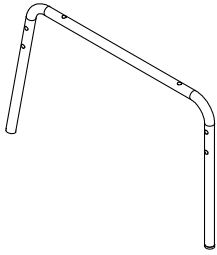

Bein linke Bank

Ⓝ x1

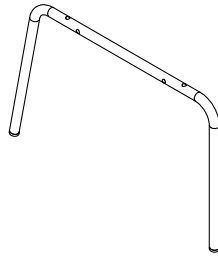

Beinrechte Bank

Ⓞ x2

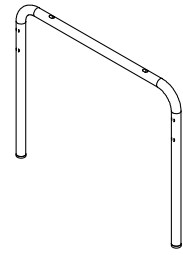

Beintisch

Ⓟ x8

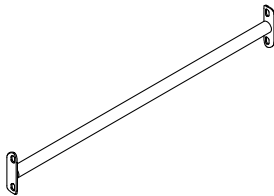

Trage

Ⓠ x2

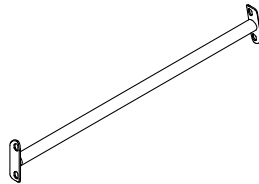

Trage

Ⓡ x2

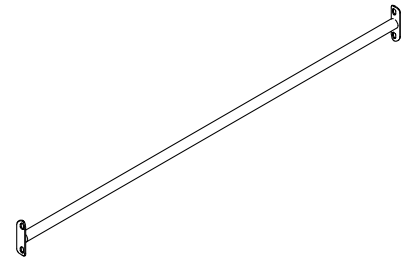

Trage

Ⓢ x1

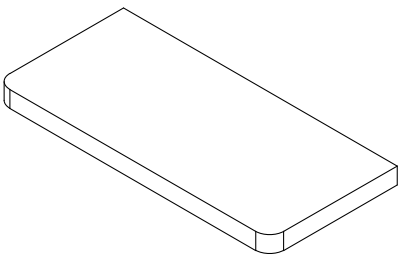

Bankkissen

Ⓣ x1

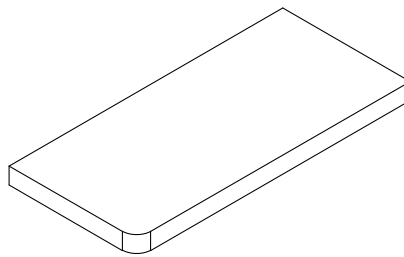

Bankkissen

Ⓤ x1

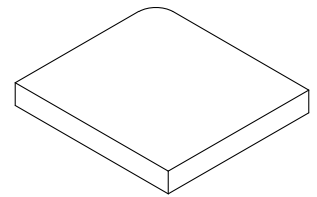

Eckkissen

Ⓥ x4

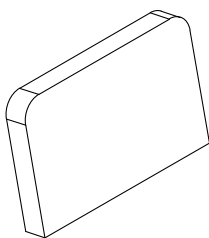

Großes Rückenissen

Ⓦ x2

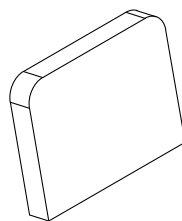

Kleines Rückenissen

Hardware Liste:

① x 8 Stück
Extra 1 Stück

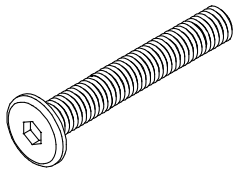

Bolzen M6 x 60 mm

② x 30 Stück
Extra 3 Stück

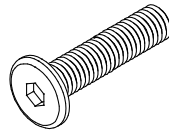

Bolzen M6 x 40 mm

③ x 12 Stück
Extra 2 Stück

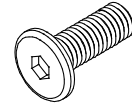

Bolzen M6 x 20 mm

④ x 26 Stück
Extra 2 Stück

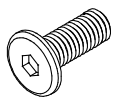

Bolzen M6 x 15 mm

⑤ x 48 Stück
Extra 3 Stück



U-Scheibe M6

⑥ x 8 Stück
Extra 1 Stück



Mutter M6

⑦ x 12 Stück
Extra 2 Stück

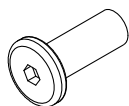

Sechskantmuttern

⑧ x 18 Stück
Extra 2 Stück

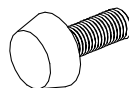

Fusskappe

⑨ x 1 Stück

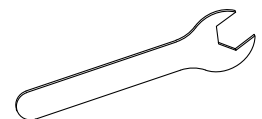

Schlüssel

⑩ x 2 Stück

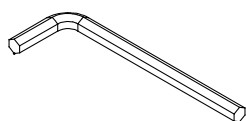

Inbusschlüssel

⑪ x 1 Stück

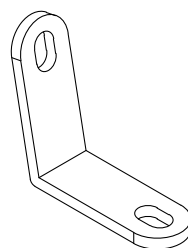

Halteplatte

INHALT DES KARTONS:

WF317139

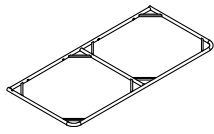

C x 1

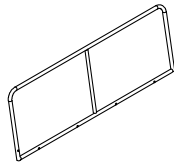

D x 1

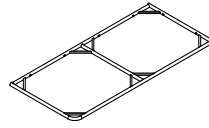

E x 1

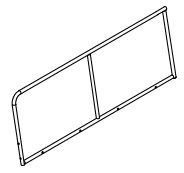

F x 1

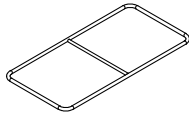

H x 1

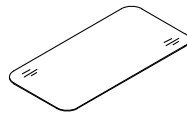

I x 1

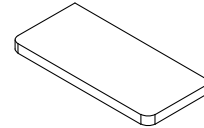

S x 1

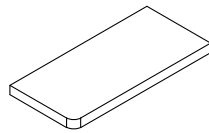

T x 1

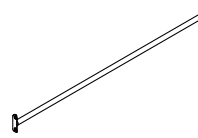

R x 2

WF317140

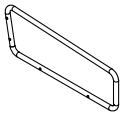

A x 1

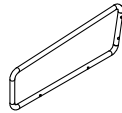

B x 1

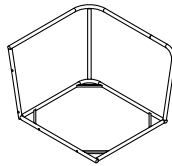

G x 1

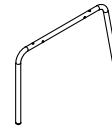

J x 1



K x 1

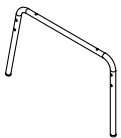

L x 3

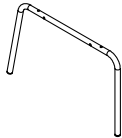

M x 1

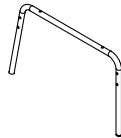

N x 1

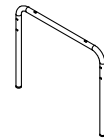

O x 2

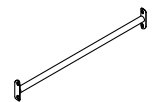

P x 8

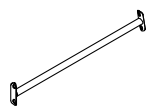

Q x 2

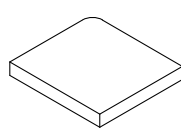

U x 1

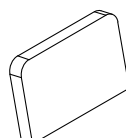

V x 4

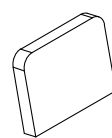

W x 2

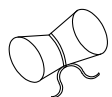

HARDWARE

SCHRITT 1

- ⓐ x 1
- ⓑ x 1
- ⓒ x 1
- ⓓ x 1
- ⓔ x 6
- ⓕ x 6

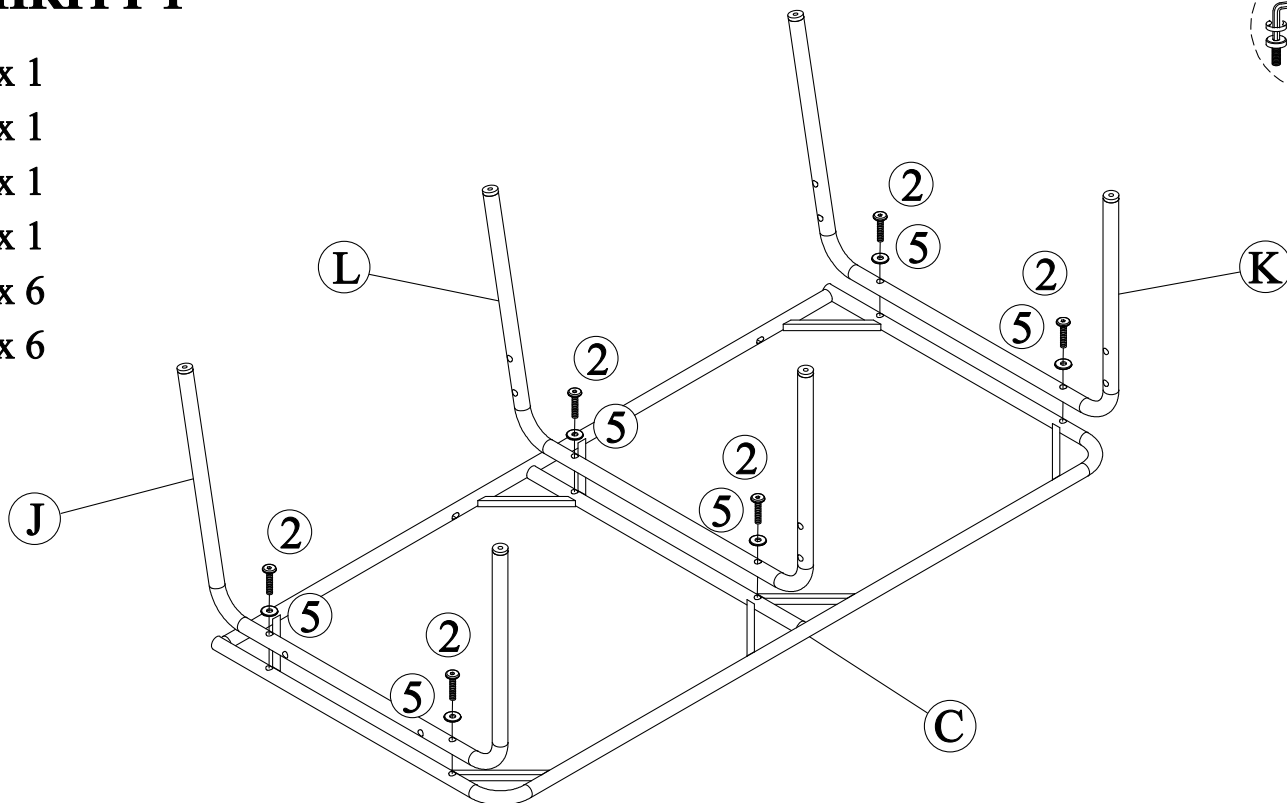
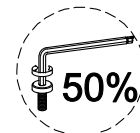

Verbinden Sie den Sitzbankrahmen (C) und das linke Bein der Bank (J) sowie das rechte Bein der Bank (K) und das mittlere Bein (L) mit der Schraube (2) und den Unterlegscheiben (5).

SCHRITT 2

- ⓖ x 4
- ⓗ x 4
- ⓘ x 8
- ⓙ x 4

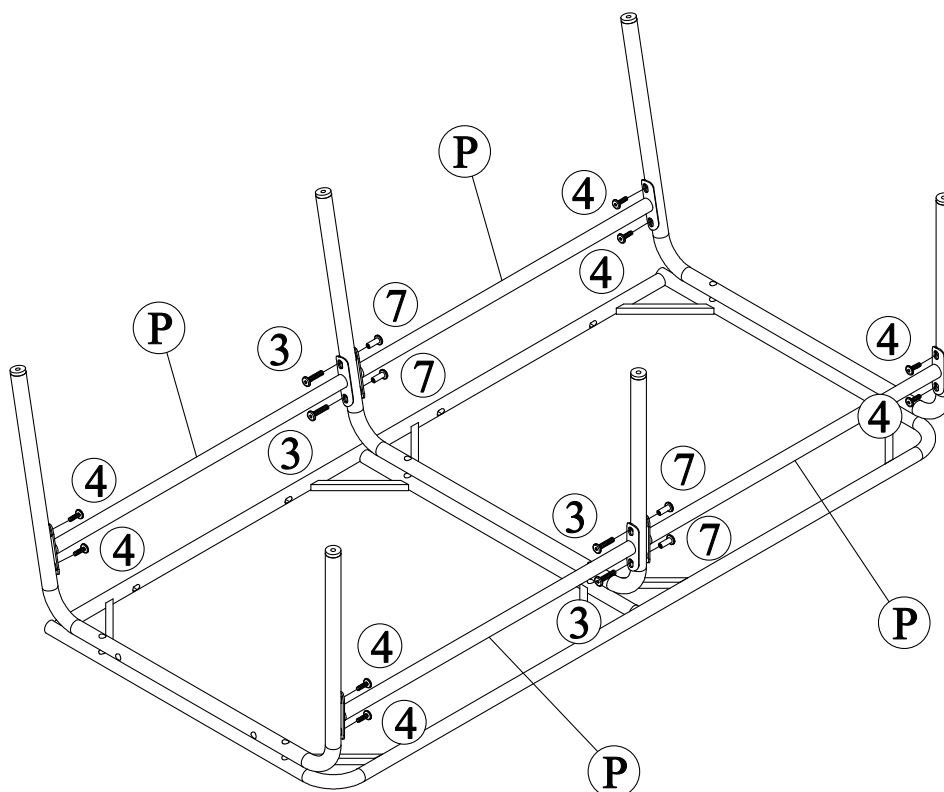
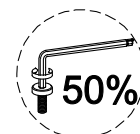

Verbinden Sie das Teil aus Schritt 1 und die Trage (P) mit den Schrauben (3), (4) und den Sechskantmutter (7).

SCHRITT 3

8 x 6

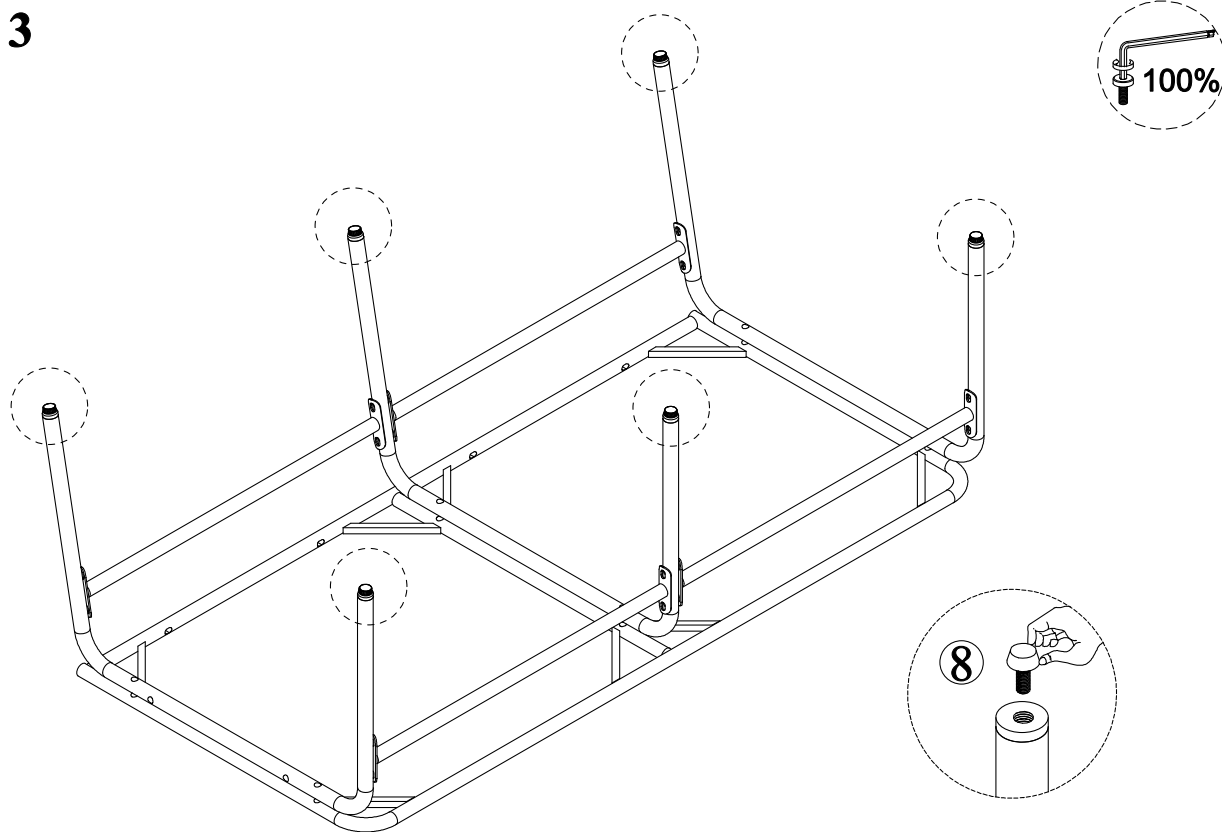

Verbinden Sie Teil aus Schritt 2 mit der Fußkappe (8).

SCHRITT 4

D x 1
1 x 4
5 x 8
6 x 4

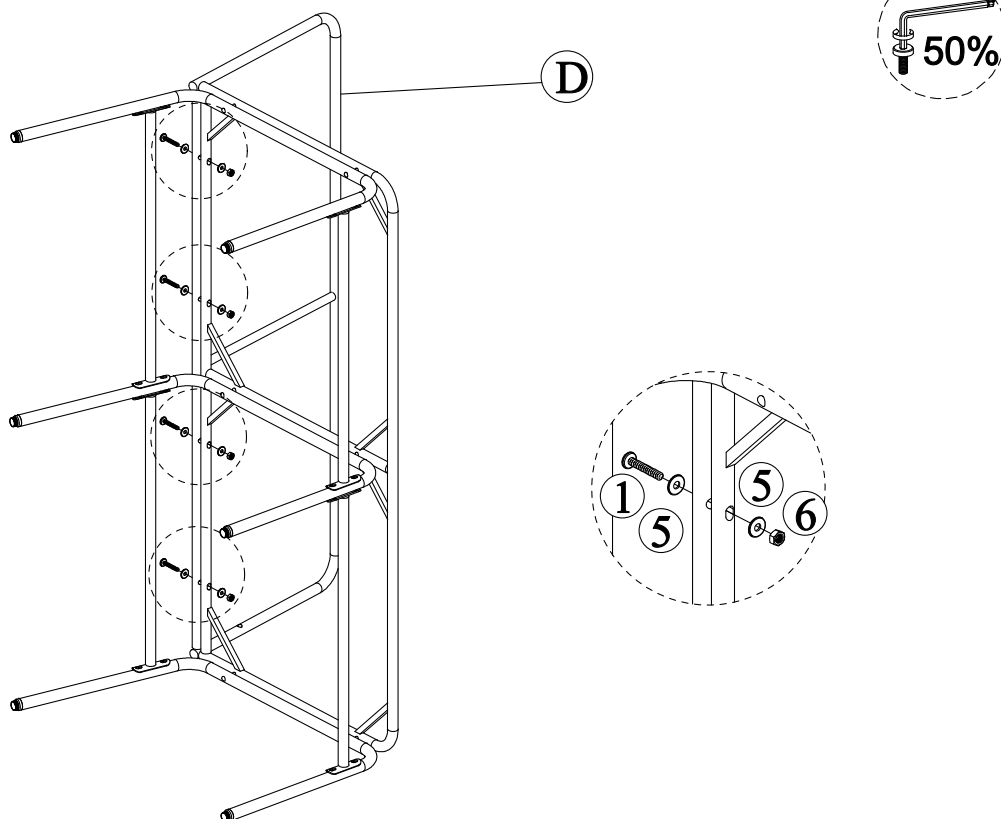

Verbinden Sie das Teil von Schritt 3 und den hinteren Bankrahmen (D) mit Bolzen (1), Unterlegscheiben (5) und Eru (6).

SCHRITT 5

- ⓑ x 1
- ② x 4
- ⑤ x 4

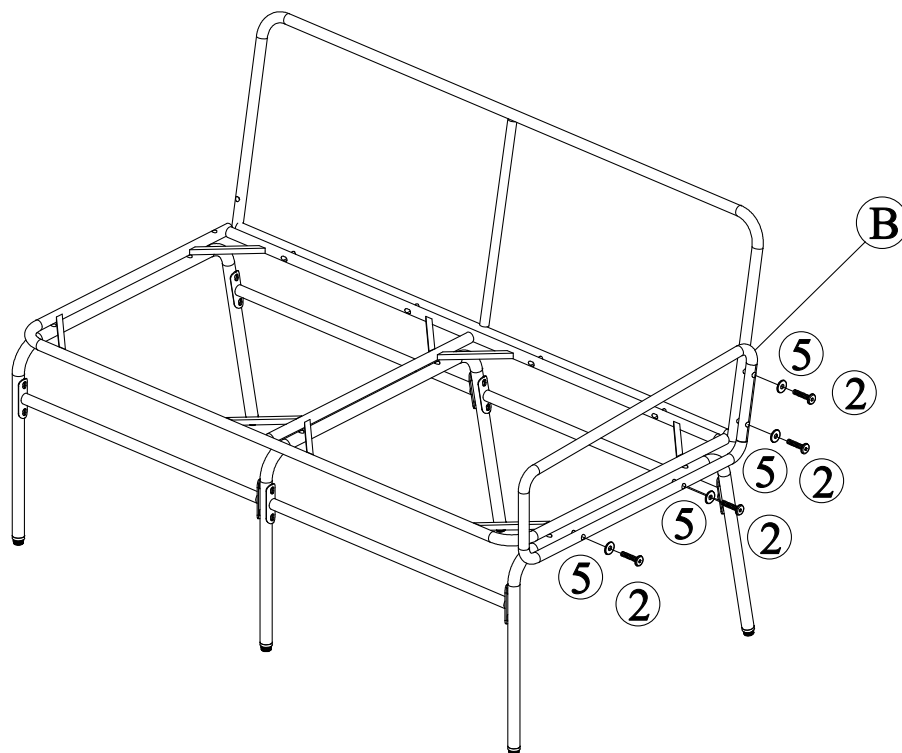

Verbinden Sie das Teil aus Schritt 4 und den linken Rahmenarm (B) mit der Schraube (2) und den Unterlegscheiben (5).

SCHRITT 6

- ④ x 2
- ⑤ x 2
- ⑪ x 1

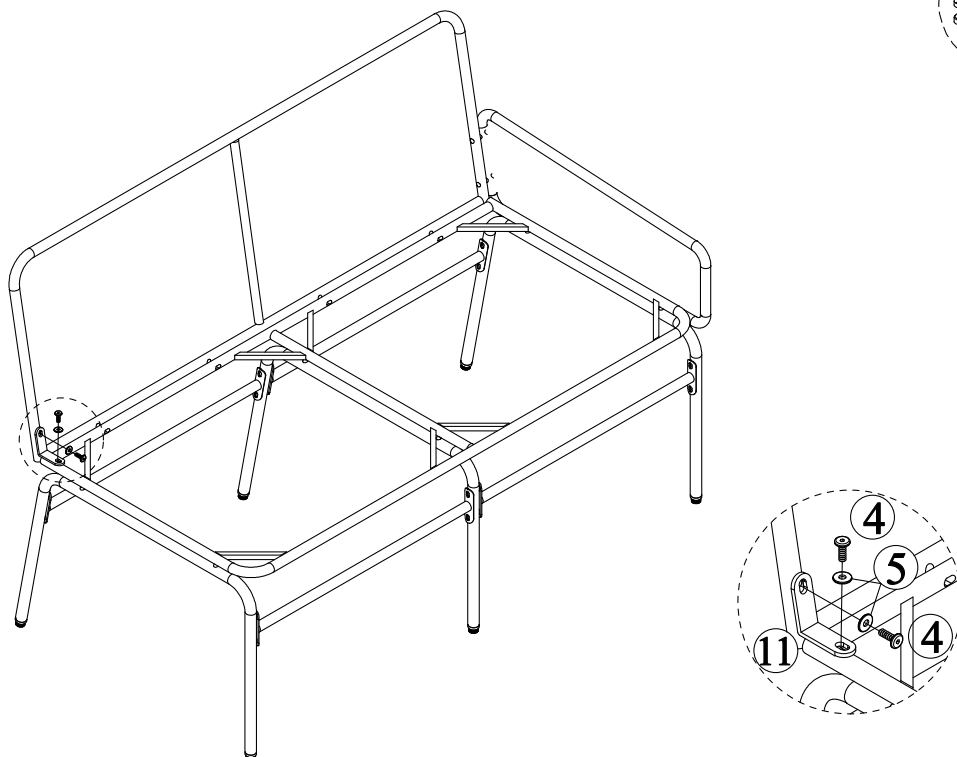

Verbinden Sie das Teil aus Schritt 5 und die Halteplatte (11) mit der Schraube (4) und den Unterlegscheiben (5).

SCHRITT 7

Ⓢ x 1

Ⓥ x 2

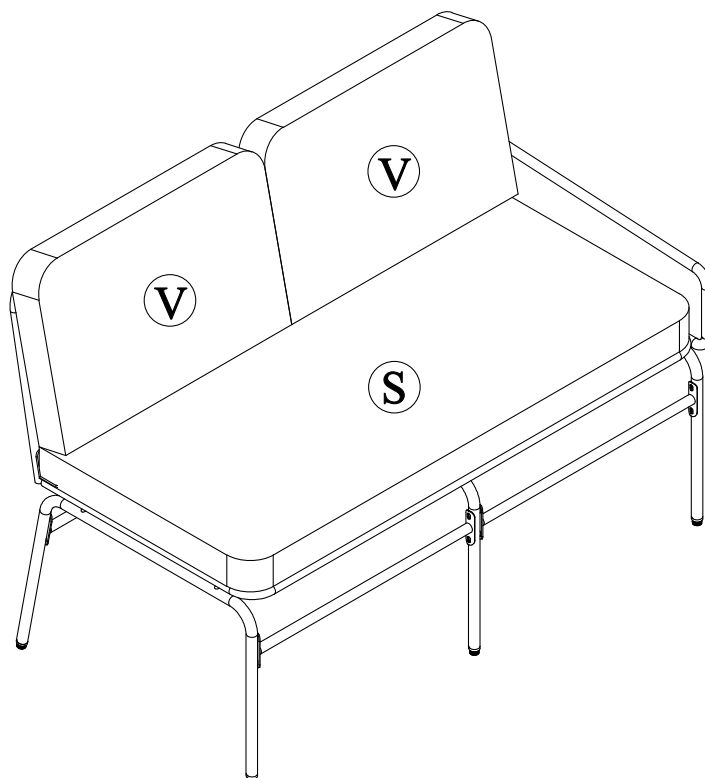

Setzen Sie das Bankkissen (S) und das große Rückenkissen (V) auf, um die Bank zu vervollständigen

SCHRITT 8

ⓔ x 1

ⓕ x 1

① x 4

⑤ x 8

⑥ x 4

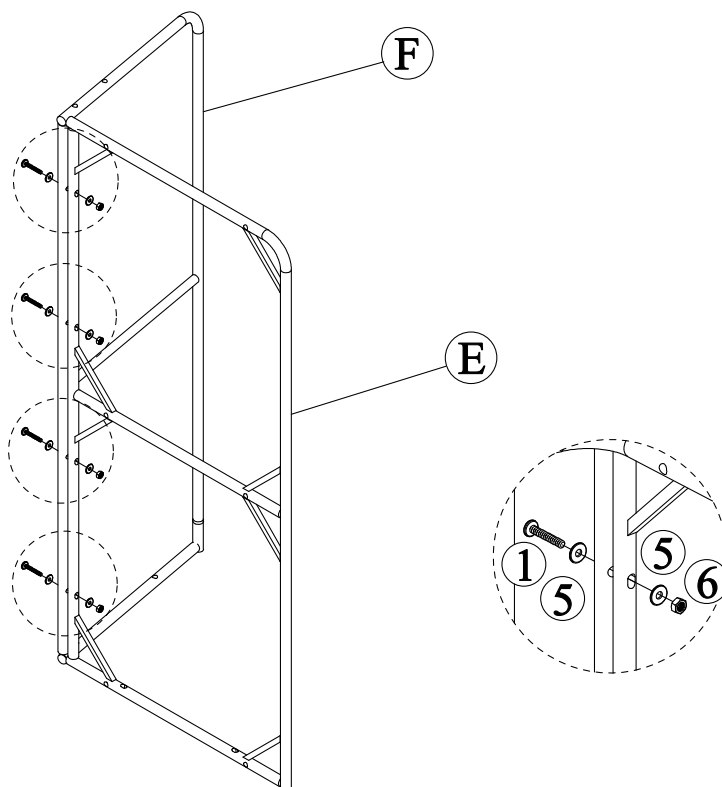

Verbinden Sie den Sitzbankrahmen (E) und den Rückbankrahmen (F) mit Bolzen (1), Unterlegscheiben (5) und Eru (6).

SCHRITT 9

- ⓐ x 1
- ⓑ x 2
- ⓓ x 2

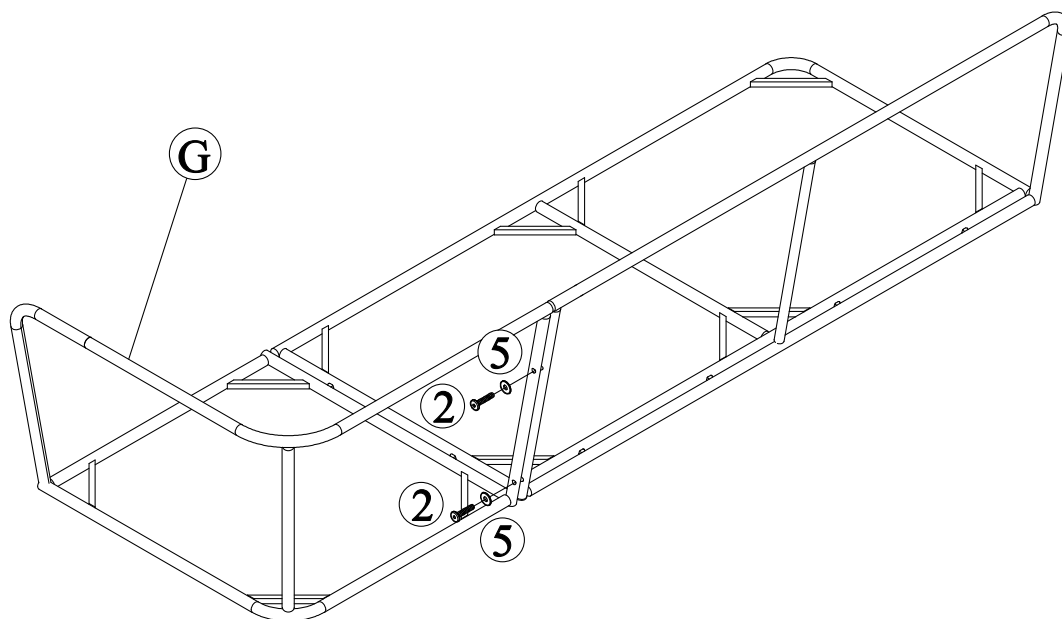

Verbinden Sie das Teil aus Schritt 8 und den Eckrahmen der Bank (G) mit der Schraube (2) und den Unterlegscheiben (5).

SCHRITT 10

- ⓑ x 2
- ⓓ x 2

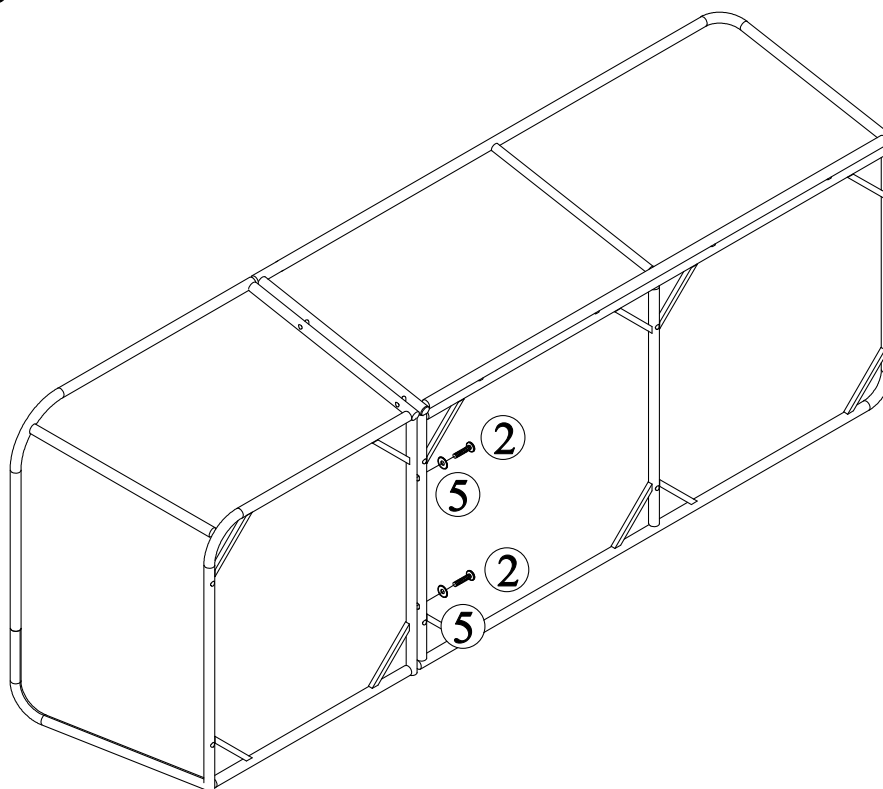

Verbinden Sie das Teil aus Schritt 9 und den Eckrahmen der Bank (G) mit der Schraube (2) und den Unterlegscheiben (5).

SCHRITT 11

- Ⓛ x 2
- Ⓜ x 1
- Ⓝ x 1
- ② x 8
- ⑤ x 8

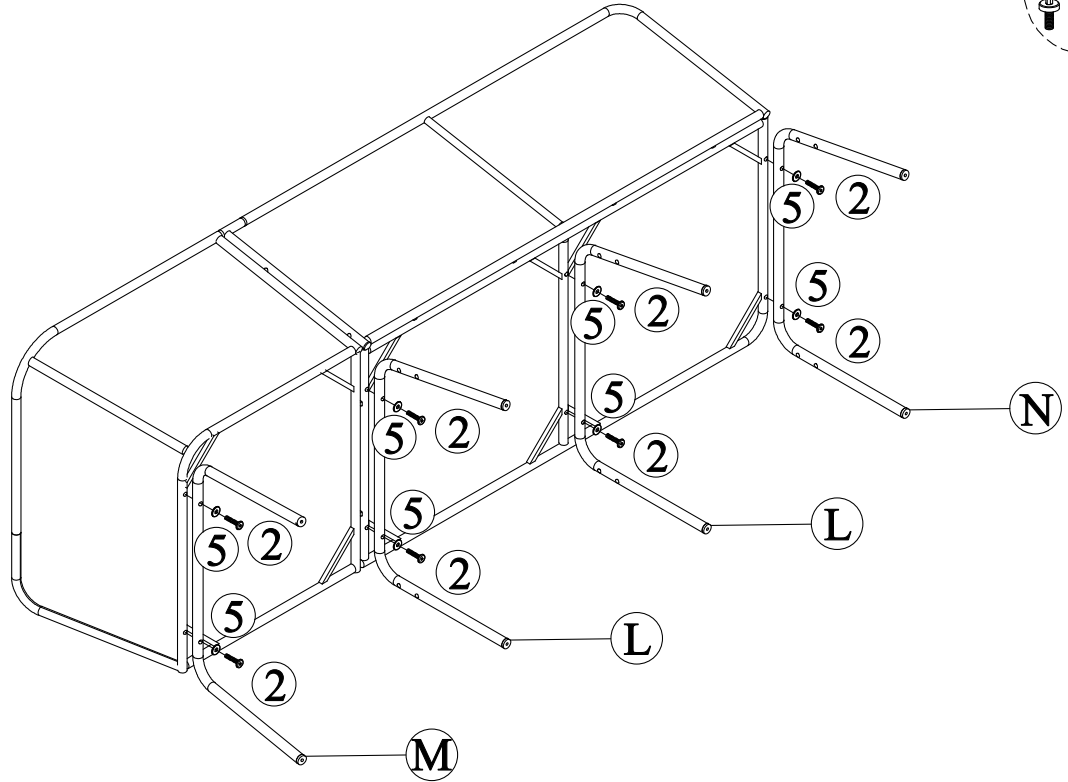

Verbinden Sie das Teil aus Schritt 10 und das linke Bein der Bank (M), das rechte Bein der Bank (N) und das mittlere Bein (L) mit der Schraube (2) und den Unterlegscheiben (5).

SCHRITT 12

- Ⓟ x 4
- Ⓠ x 2
- ③ x 8
- ④ x 8
- ⑦ x 8

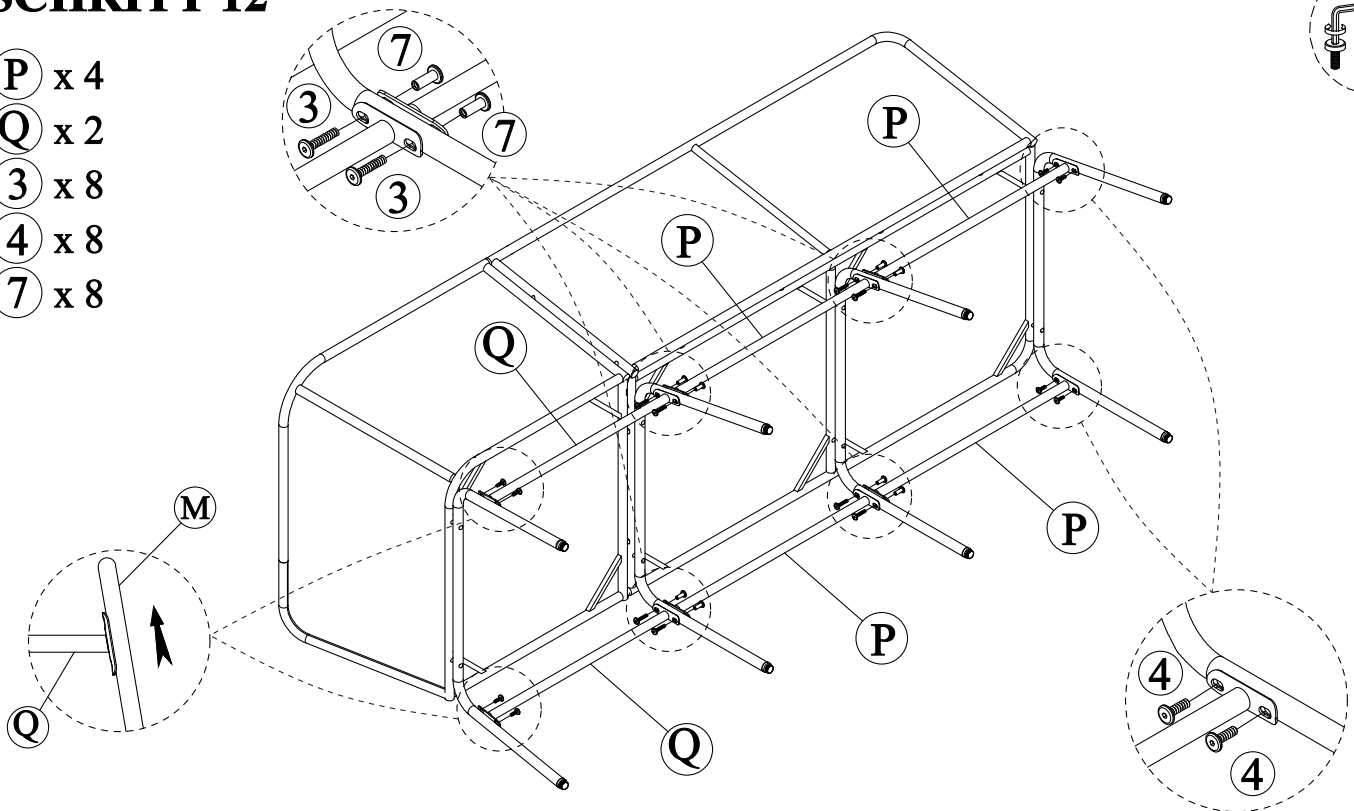

Verbinden Sie das Teil aus Schritt 11 und die Trage (P) und die Trage (Q) mit den Schrauben (3), (4) und den Sechskantmuttern (7).

SCHRITT 13

⑧ x 8

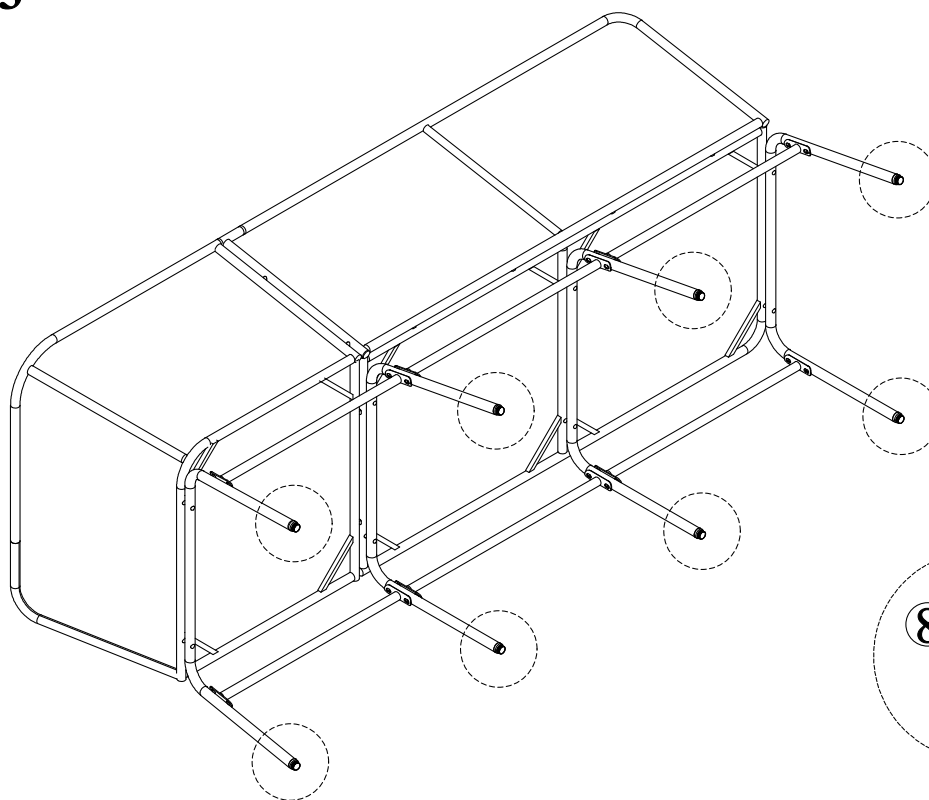

Verbinden Sie den Teil aus Schritt 12 mit der Fußkappe (8).

SCHRITT 14

Ⓐ x 1

② x 4

⑤ x 4

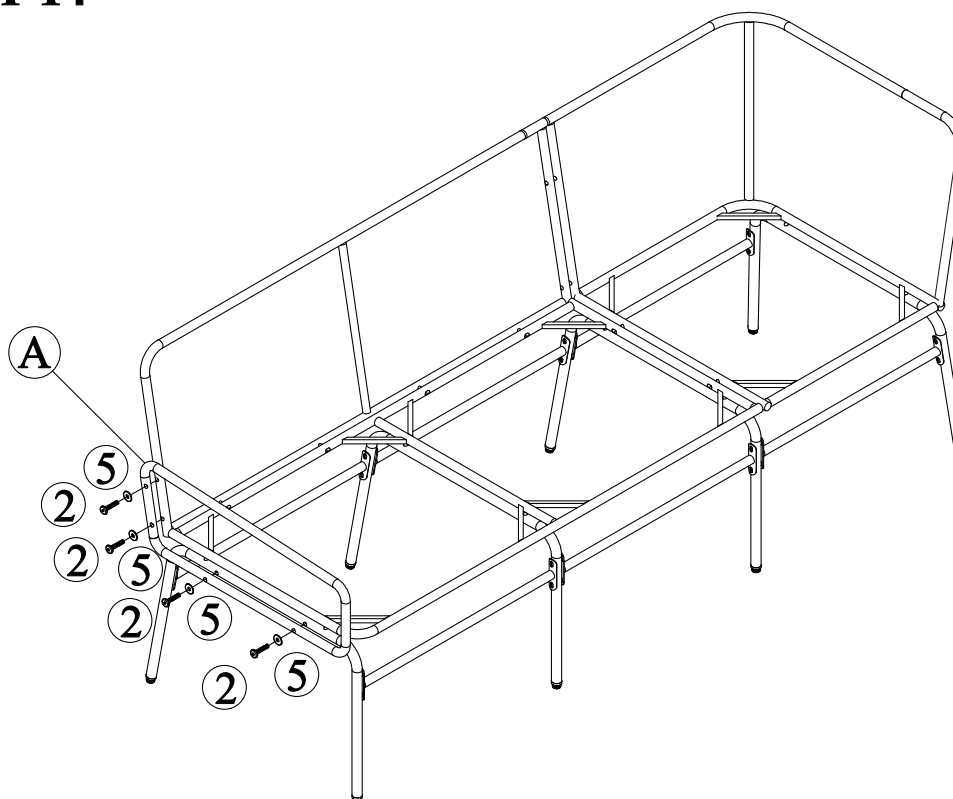

Verbinden Sie das Teil aus Schritt 13 und den rechten Rahmenarm (A) mit der Schraube (2) und den Unterlegscheiben (5).

SCHRITT 15

- Ⓣ x 1
- Ⓤ x 1
- Ⓥ x 2
- Ⓦ x 2

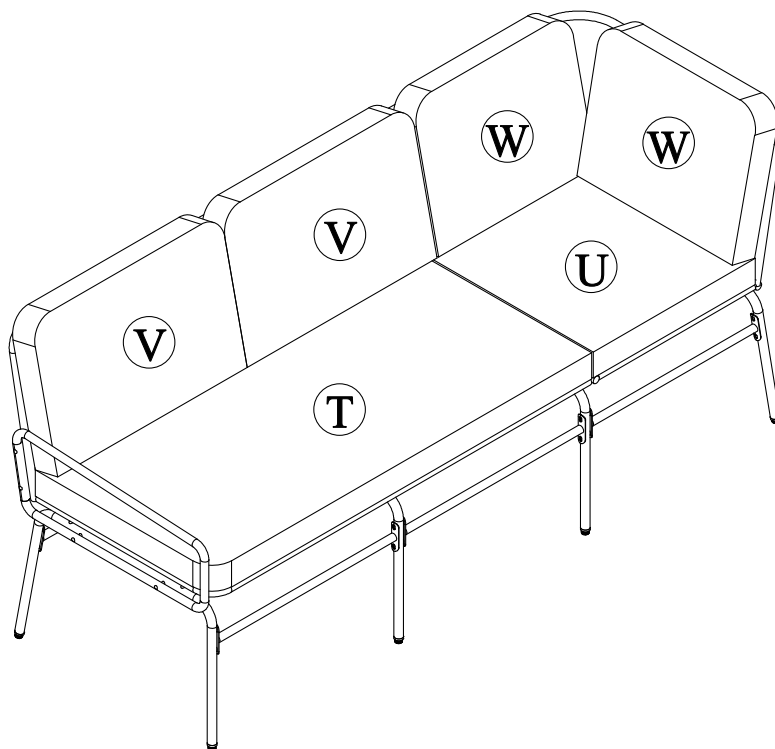

Setzen Sie das Bankkissen (T) und das Eckkissen (U) sowie das große Rückenkissen (V) und das kleine Rückenkissen (W) auf, um die Eckbank zu vervollständigen

SCHRITT 16

- ⓓ x 1
- ⓐ x 2
- ⓑ x 4
- ⓔ x 4

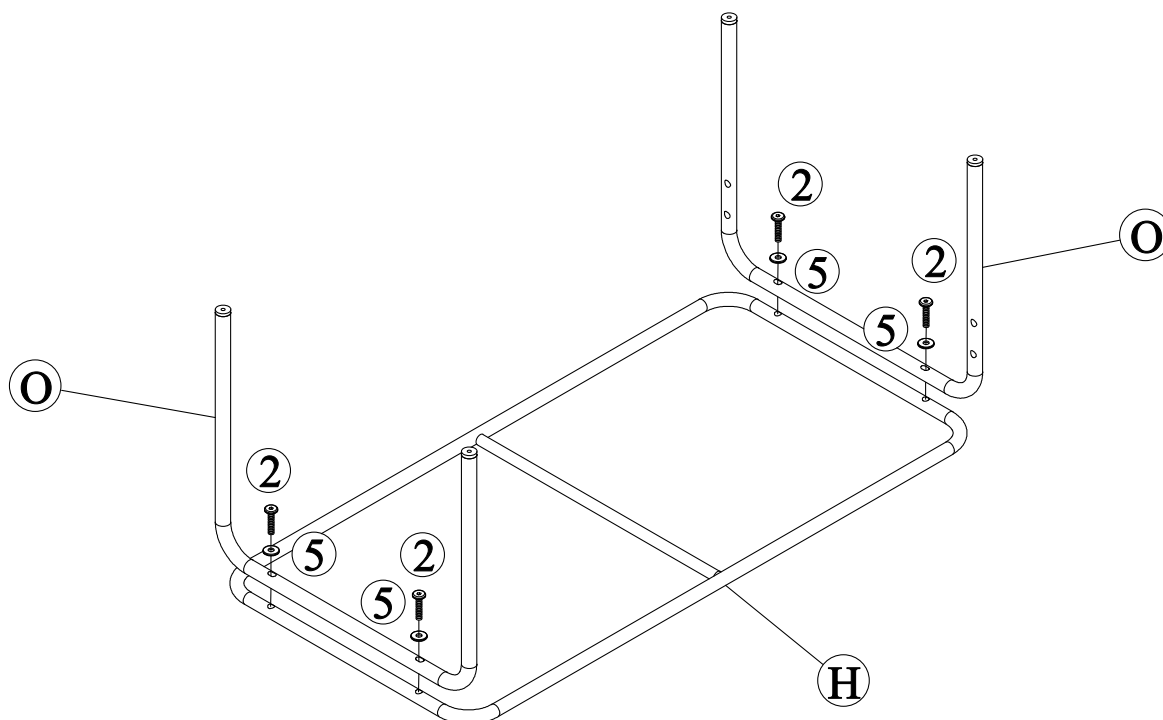

Verbinden Sie den Tischplattenrahmen (H) und den Beintisch (O) mit Bolzen (2) und Unterlegscheiben (5).

SCHRITT 17

Ⓡ x 2

④ x 8

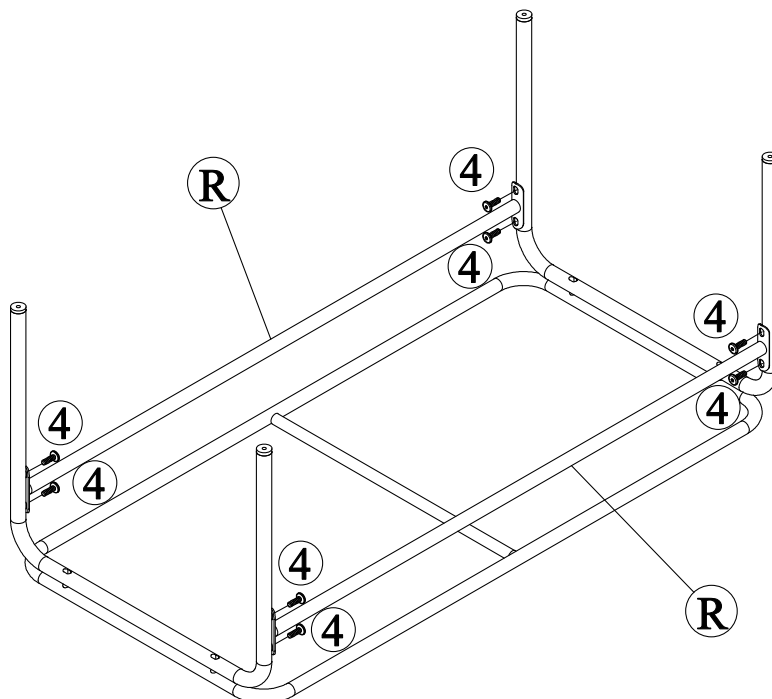

Verbinden Sie Teil von Schritt 16 und Trage (R) mit Bolzen (4).

SCHRITT 18

⑧ x 4

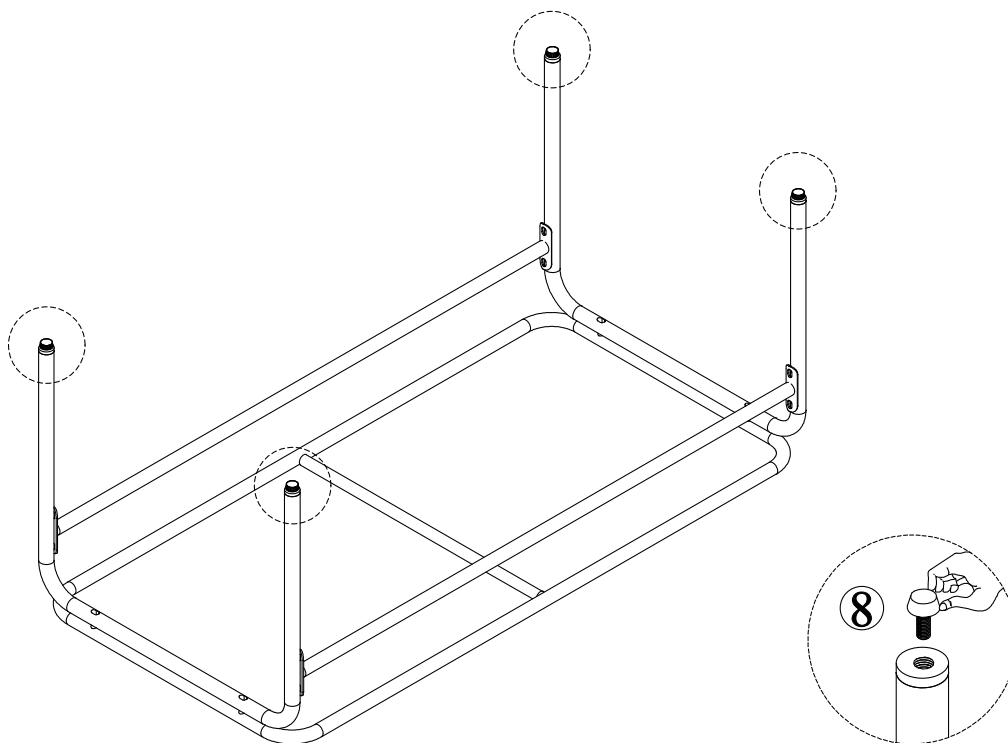

Verbinden Sie den Teil aus Schritt 17 mit der Fußkappe (8).

SCHRITT 19

Ⓘ x 1

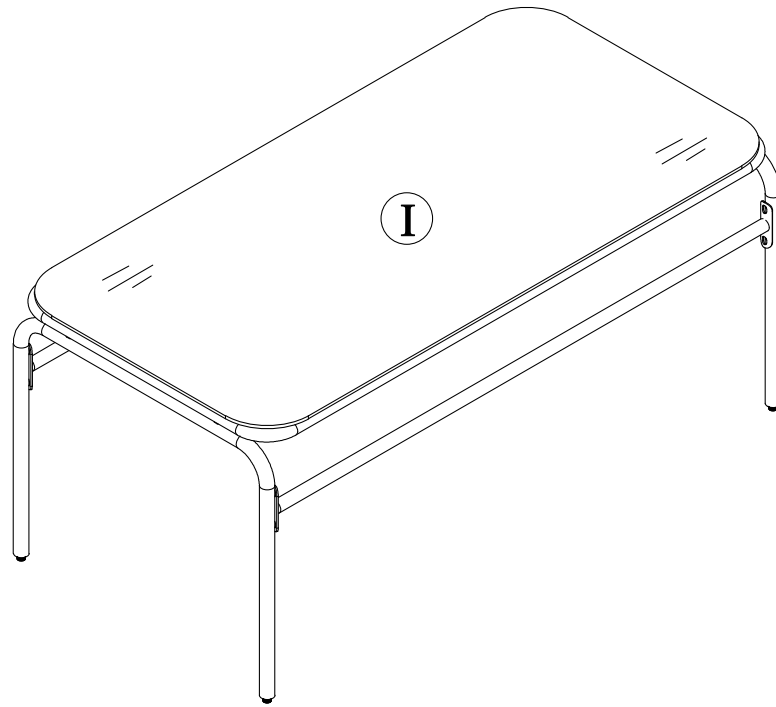

Platziere das Tischglas (I), um den Tisch zu vervollständigen

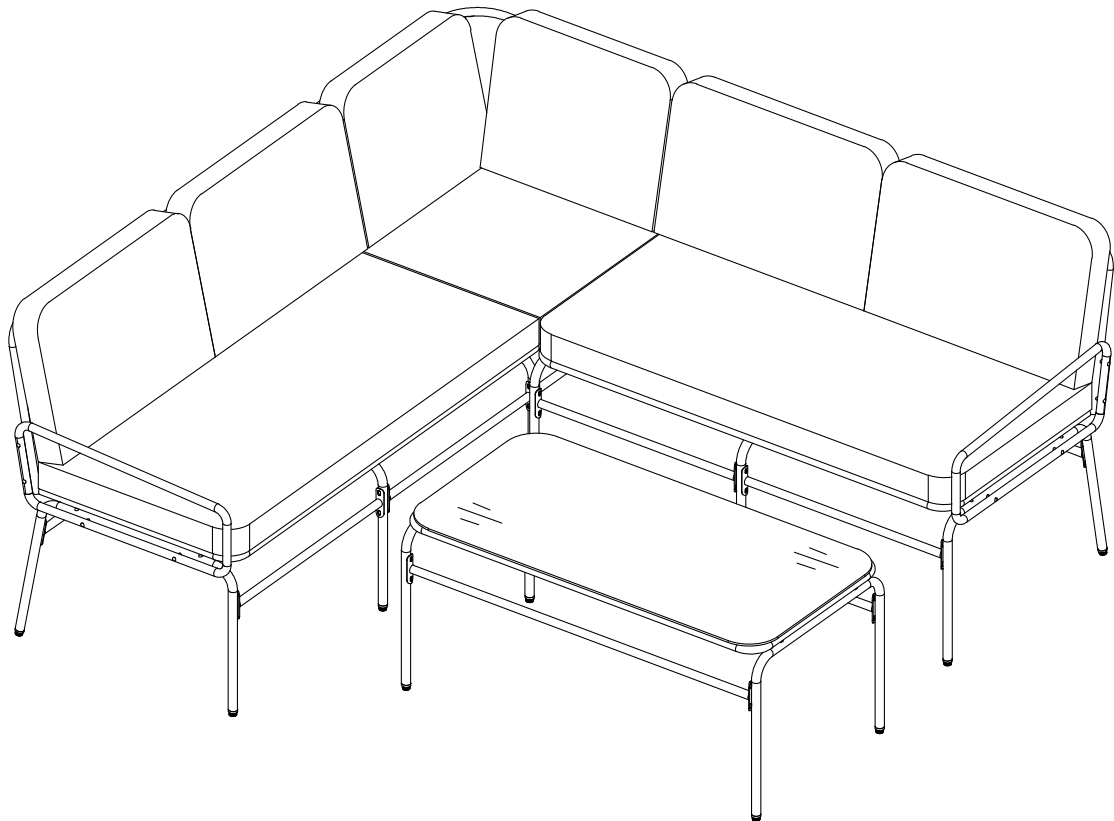

Sofa fertig stellen