

Nr	Ausmaß			St
1	758	348	15	1
2	758	348	15	1
3	300	100	12	4
4	300	100	12	4
5	396	189	18	4
6	767	396	18	1
8	758	328	15	1
9	377	322	15	1
10	328	100	12	4
11	800	349	15	1
12	800	370	22	1
14	339	299	2	4
15	772	391	2	1
16	772	391	2	1

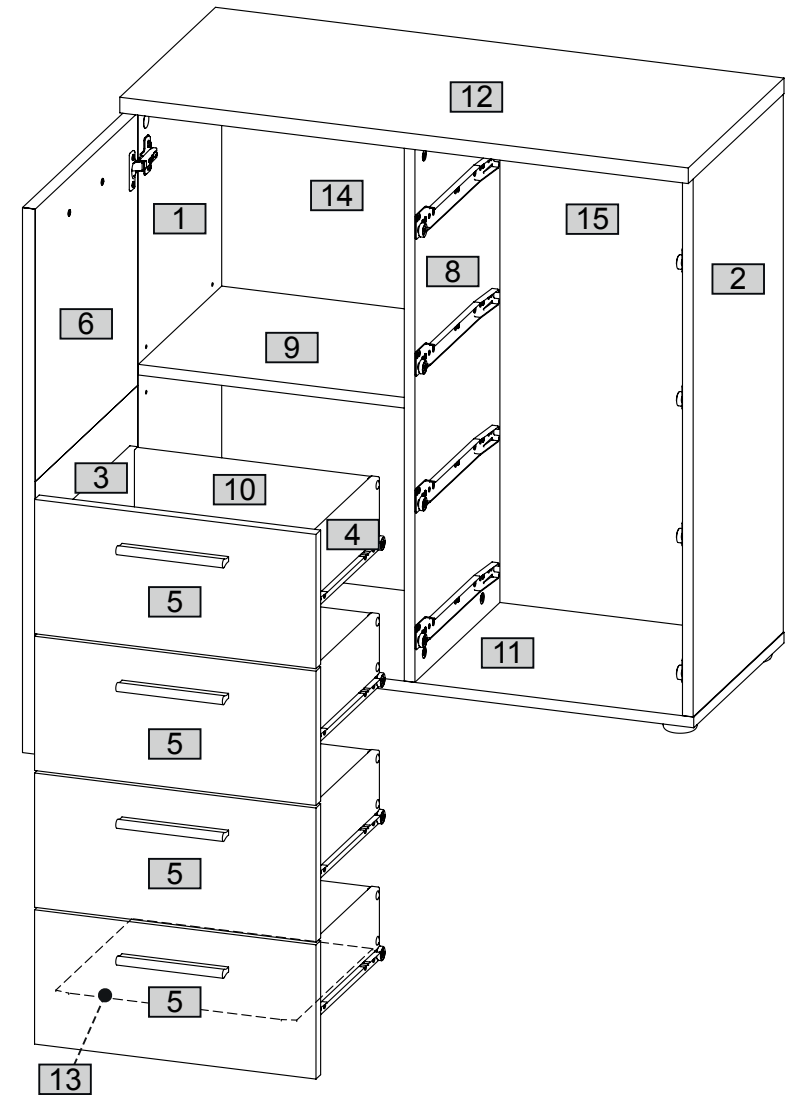

1

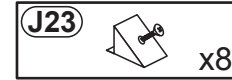
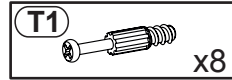
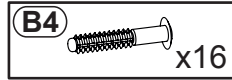
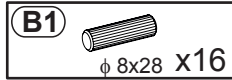
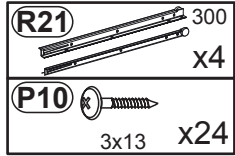

x4

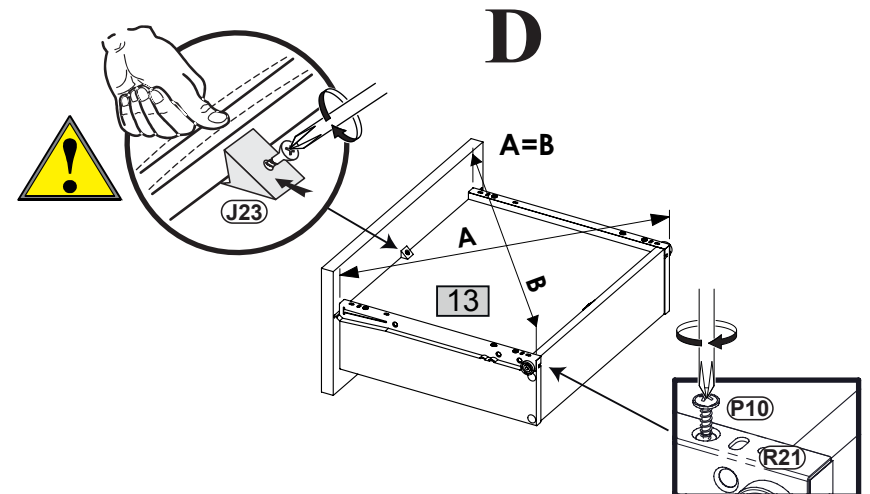
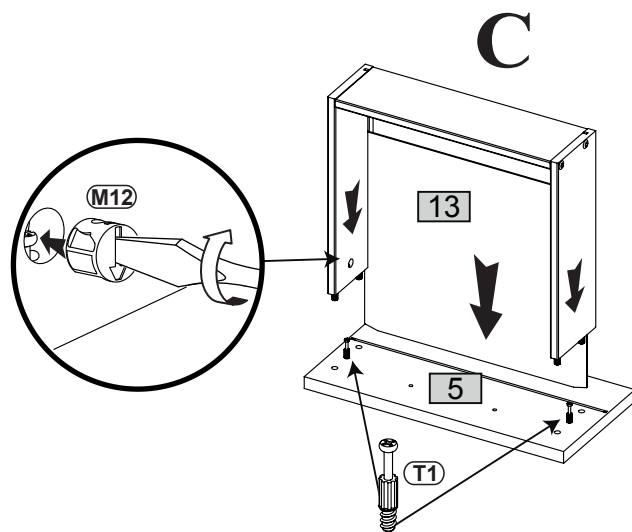
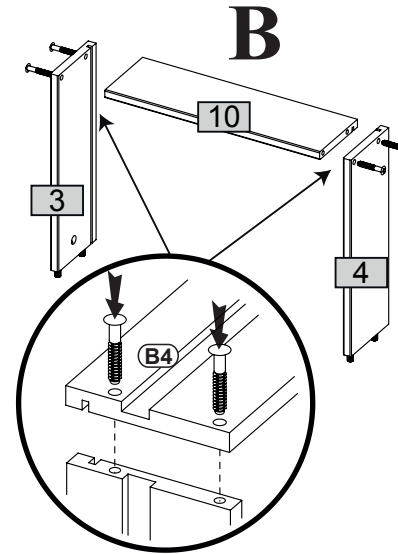
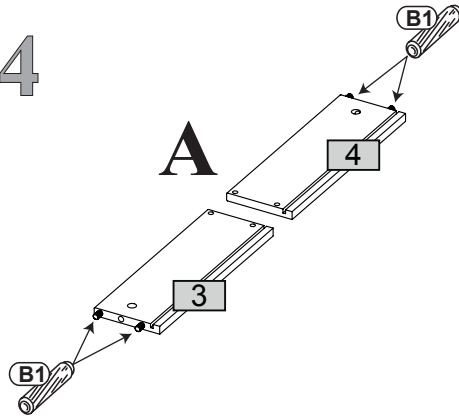

2

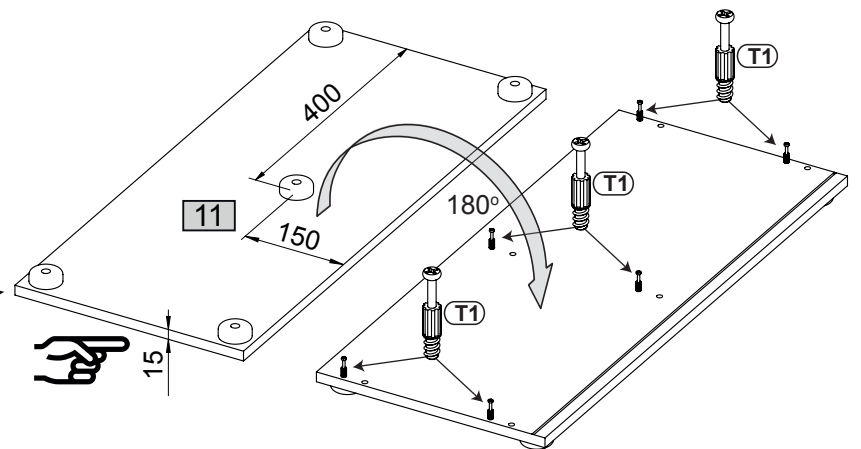
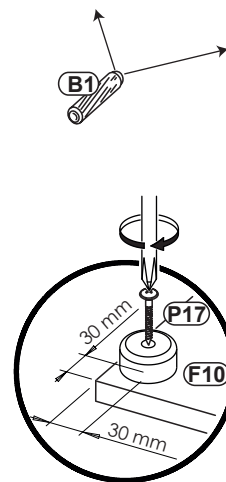
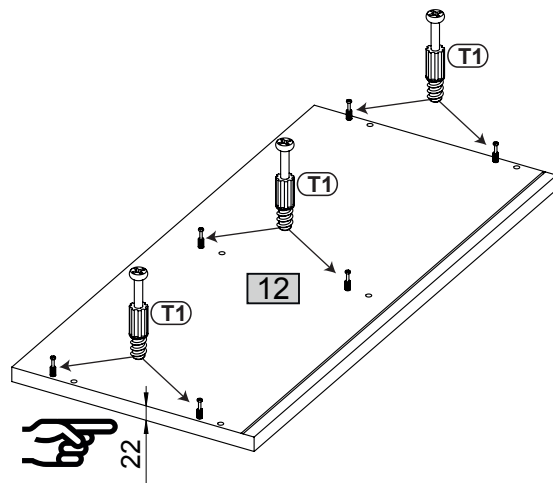
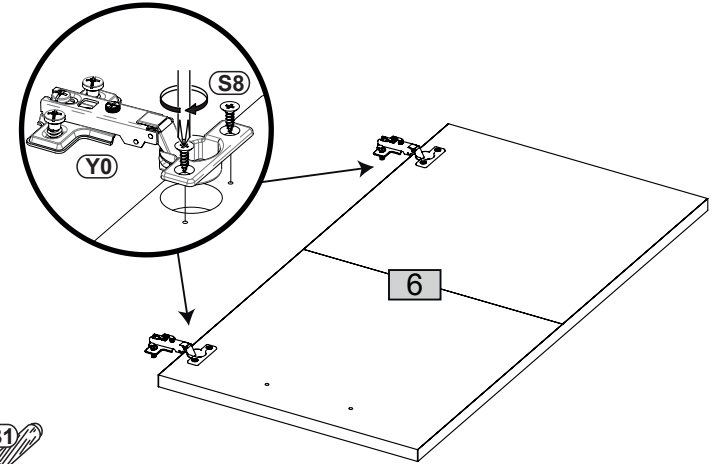
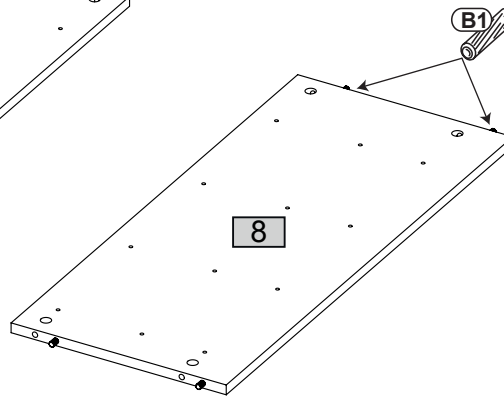
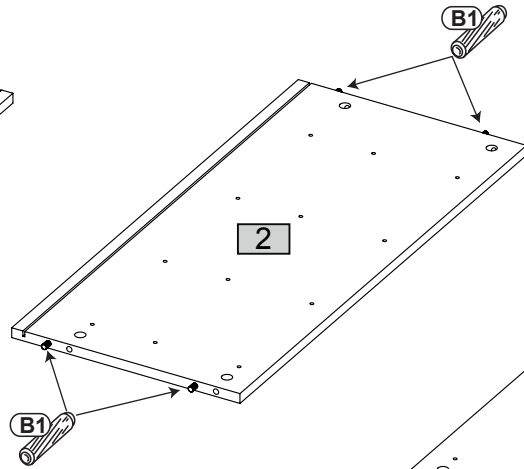
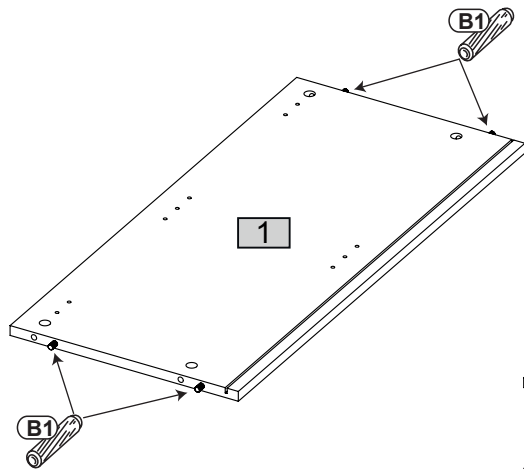
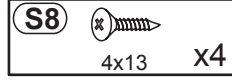
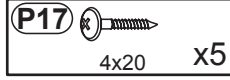
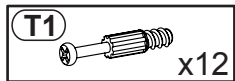
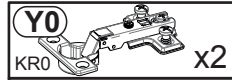
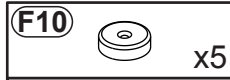
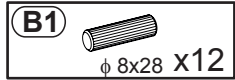

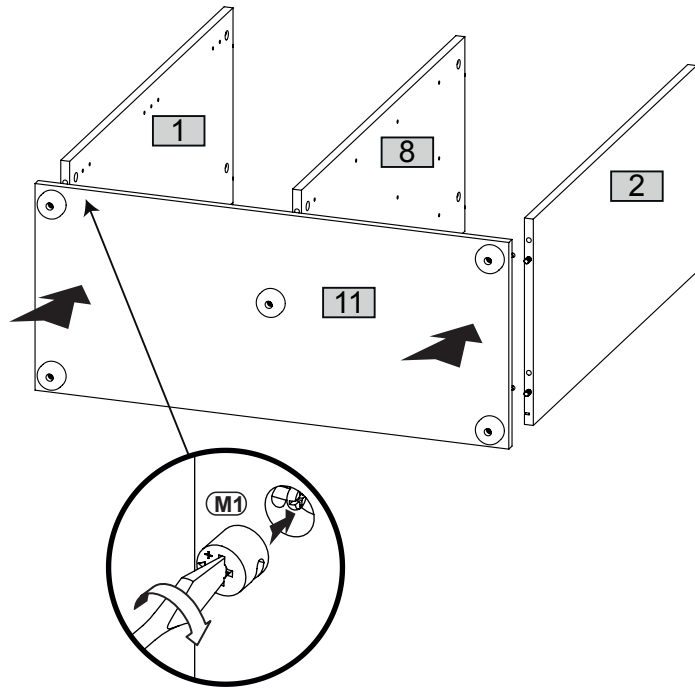

3

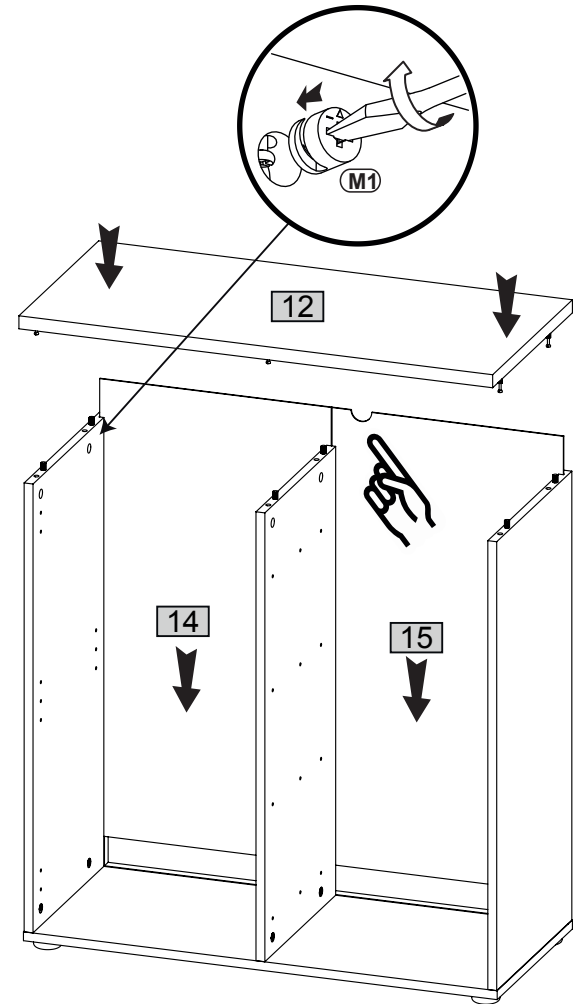

4



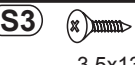

5

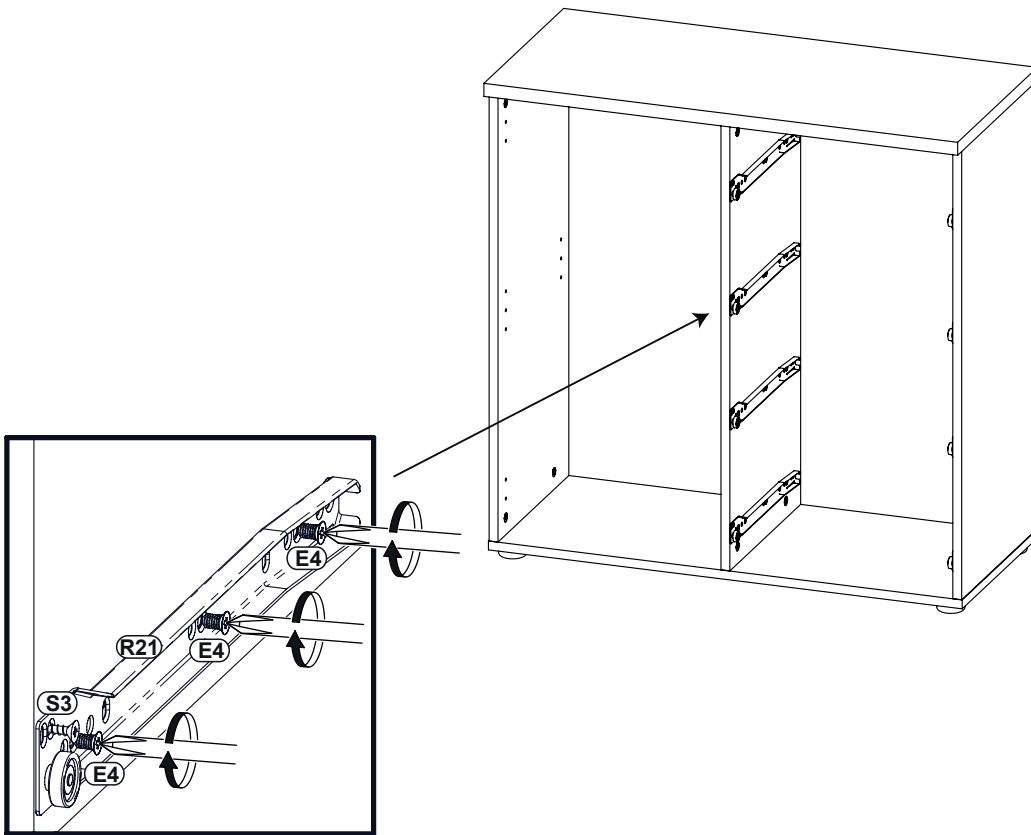
R21		300	E4		x24
		x4		6,0x8	
S3					
		x8			
		3,5x13			



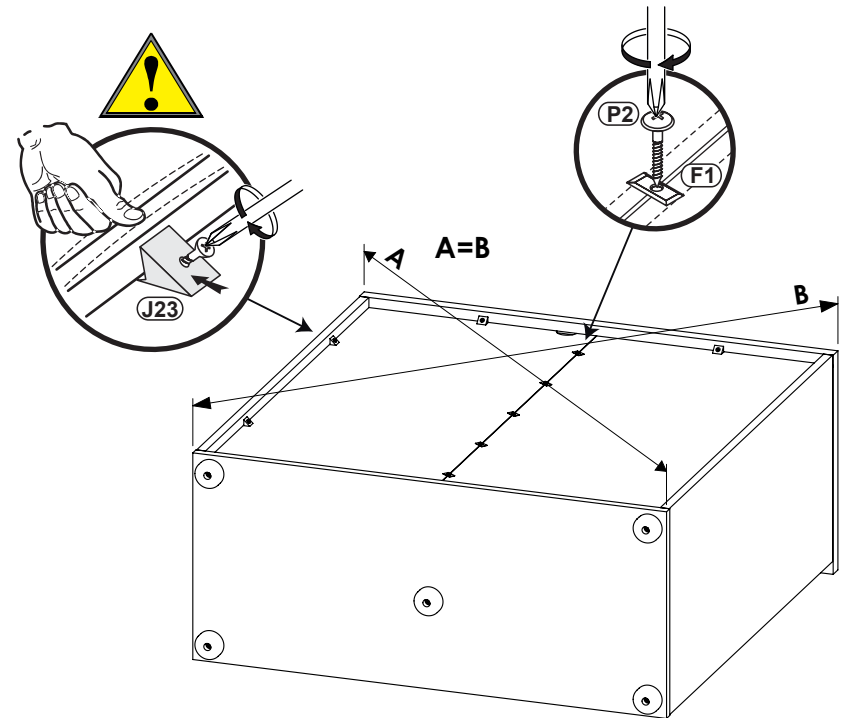

6

F1		x5	P2		3x16	x5	J23		x8
-----------	---	----	-----------	---	------	----	------------	---	----



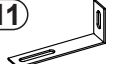
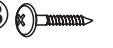

7

J11  x1	P13  3,5x13 x2	T17  5x60 $\phi 8 \times 50$ x1
---	--	---

W1  x4
--

C2  $\phi 20$ x4
--

U90  x5

P5  4x30 x10
--

