

**A**

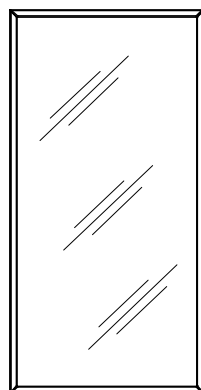

**B**

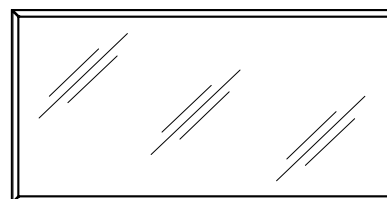

72682 72682/1

Service • Assistenza • Dienstverlening • Serwis  
 Servis • Szerviz • Сервисная служба

Name • Nom • Nome • Naam  
 Nazwa • Jméno • Názov • Név  
 Denumire • Isim • Название

Nr • No • N • Номер • Č • Sz

Typ • Type • Tip • Típus • Тіро  
 Тип

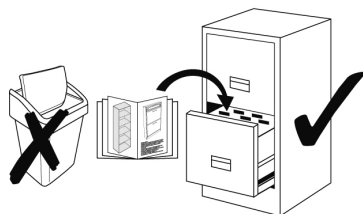
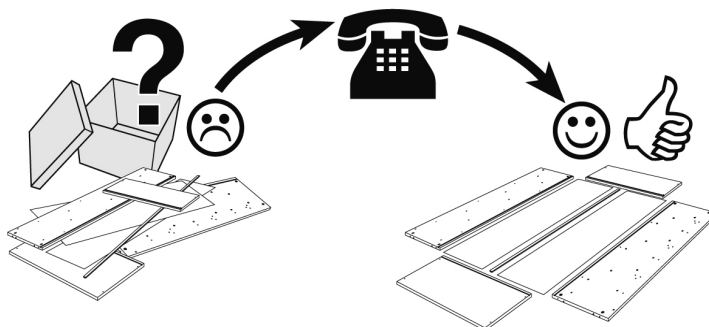

Teil Nr.

Pièces Nr.

Pieces Nr.

Часть Ном.

Kawalek Nr.

Parça No

Kusù Nr.

Kusov Nr.

Pezzi Nr.

Nr piese.

Darab száma.

Stukken Nr.

Kārtas Nr.

Anzahl

Quantité

Quantity

Количество

Ilość

Miktar

Množství

Množstvo

Quantità

Cantitatea

Mennyiség

Hoeveelheid

Skaits

Kasten Nr.

Colli Nr.

Colli Nr.

Коробка Ном.

Polu Nr.

Kutusu Nr.

Kolonka Č.

Počet balení

Colli Nr.

Nu pachete

Colli száma.

Colli Nr.

Kastes Nr.

Maß, mm

Dimensions, mm

Dimensions, mm

Размеры, mm

Wymiary, mm

Boyutlar, mm

Rozměry, mm

Rozmery, mm

Dimensioni, mm

Dimensiuni, mm

Méreték, mm

Afmetingen, mm

Izmēri, mm

01

1

1/1

1000 x 504 x 84

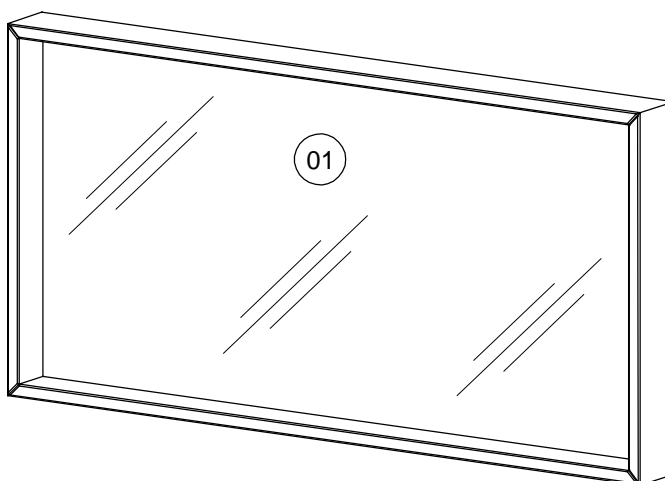

A170



x4

H20



x4

ø 8x50

A170		x4	H20		x4
					ø8x50

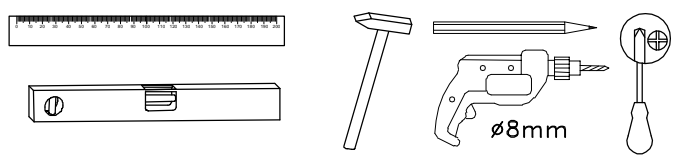

**A**

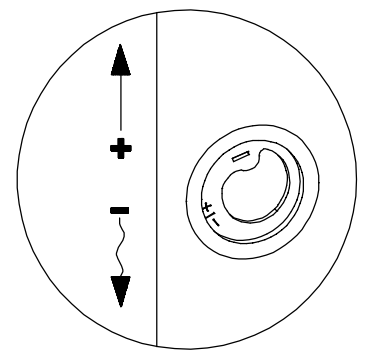
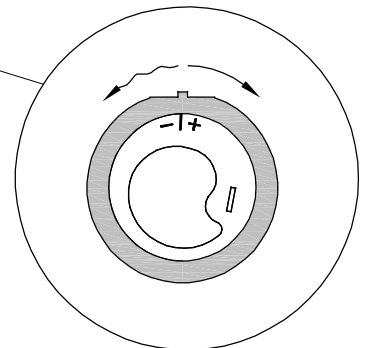
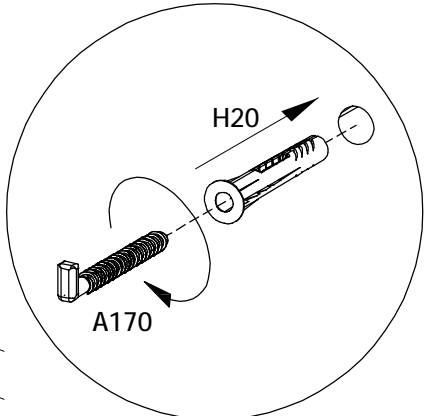
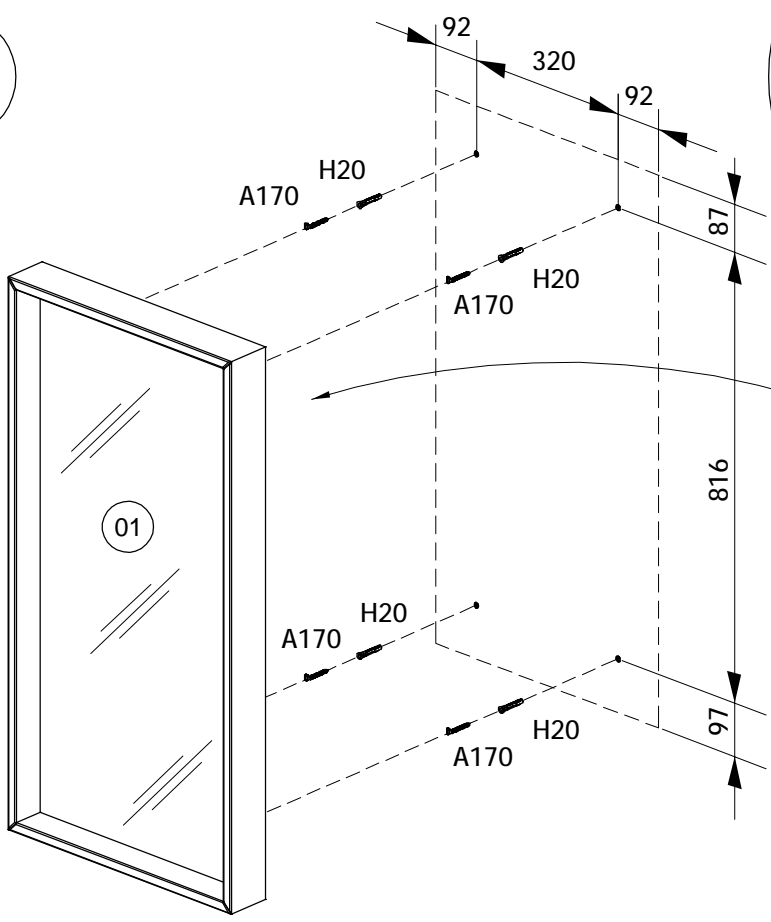

**B**

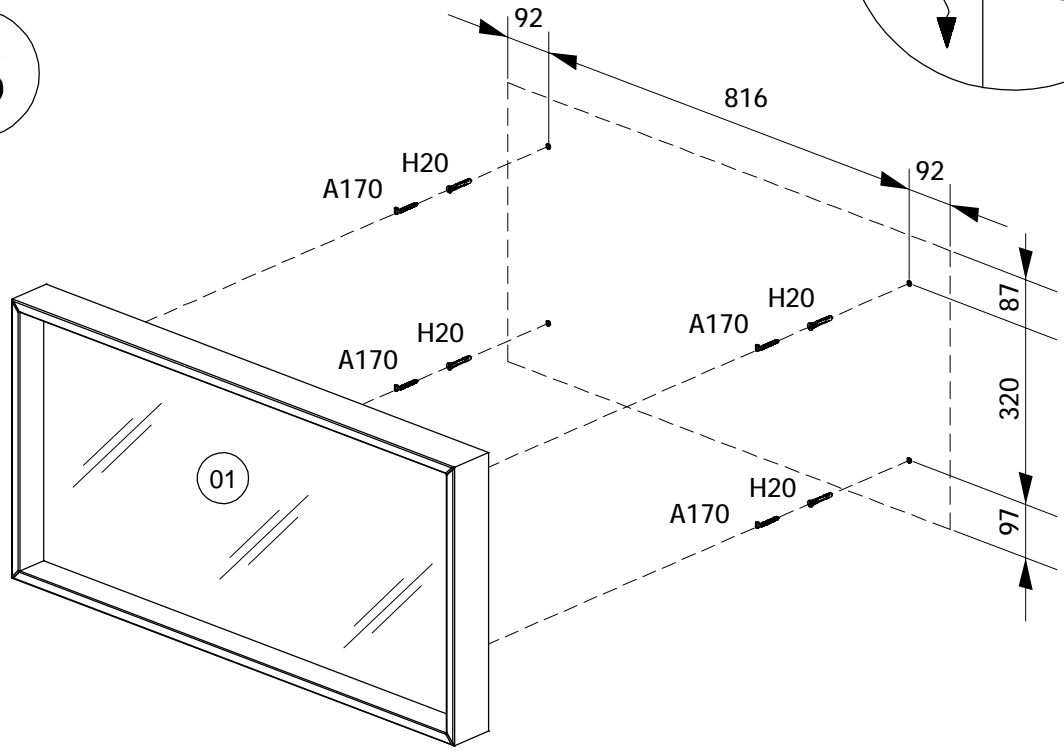

72682 72682/1

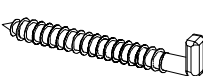
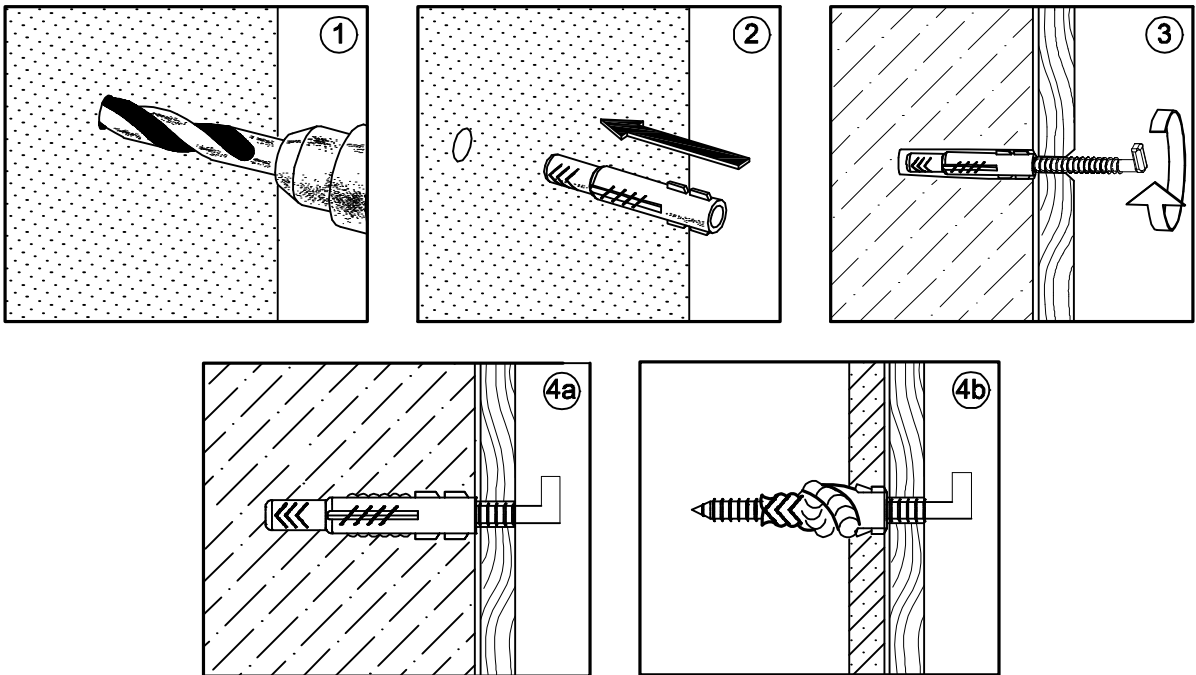
H20 A170   $\varnothing 8\text{mm}$ 

- D** **Achtung:** Die Befestigung des Möbelstückes an der Wand muss von einer fachkundigen Person vorgenommen werden, da für die Montage an die Wand angepasste Dübel erforderlich sind.
- GB** **Attention:** A qualified professional is required when mounting furniture to the wall since dowels corresponding to the wall are required for this.
- FR** **Attention :** La fixation du meuble contre le mur doit être effectuée par une personne compétente car, pour le montage mural, il faut utiliser des chevilles adaptées.
- IT** **Attenzione:** Il fissaggio del mobile alla parete deve essere eseguito da persone esperte, dato che occorrono tasselli adeguati.
- NL** **Opgelet:** een vakkundige persoon dient het meubelstuk aan de muur te bevestigen; voor de montage aan de muur zijn immers aangepaste pluggen vereist.
- PL** **Uwaga:** Mocowanie mebla do ściany mogą przeprowadzić wyłącznie wykwalifikowane osoby, z uwagi na zastosowanie odpowiednio dopasowanych kołków do rodzaju ściany.
- CZ** **Pozor:** Montáž nábytku na stěnu musí provést odborník, protože k montáži na stěnu jsou zapotřebí upravené hmoždinky.
- SK** **Pozor:** Upevnenie nábytku na stenu musí vykonať odborník, nakoľko sú pre montáž na stenu potrebné vhodné hmoždinky.
- HU** **Figyelem:** A bútorelemek falra rögzítését szakembernek kell végeznie, mert a rögzítéshez megfelelő tiplít kell használni.
- RO** **Atenție:** Fixarea la perete a piesei de mobilier se realizează numai de către personal competent, deoarece montajul de perete necesită dibluri adecvate.
- TR** **Dikkat:** Mobilya parçasının duvara sabitlenmesi, duvar montajı için özel uyarlanmış dübeller gerektirdiğinden bu iş sadece bu konuda uzman bir kişi tarafından gerçekleştirilmelidir.
- RU** **Внимание:** Поскольку для монтажа на стене необходимо использовать специальные дюбели, мебель должна быть закреплена на стене квалифицированным персоналом.