

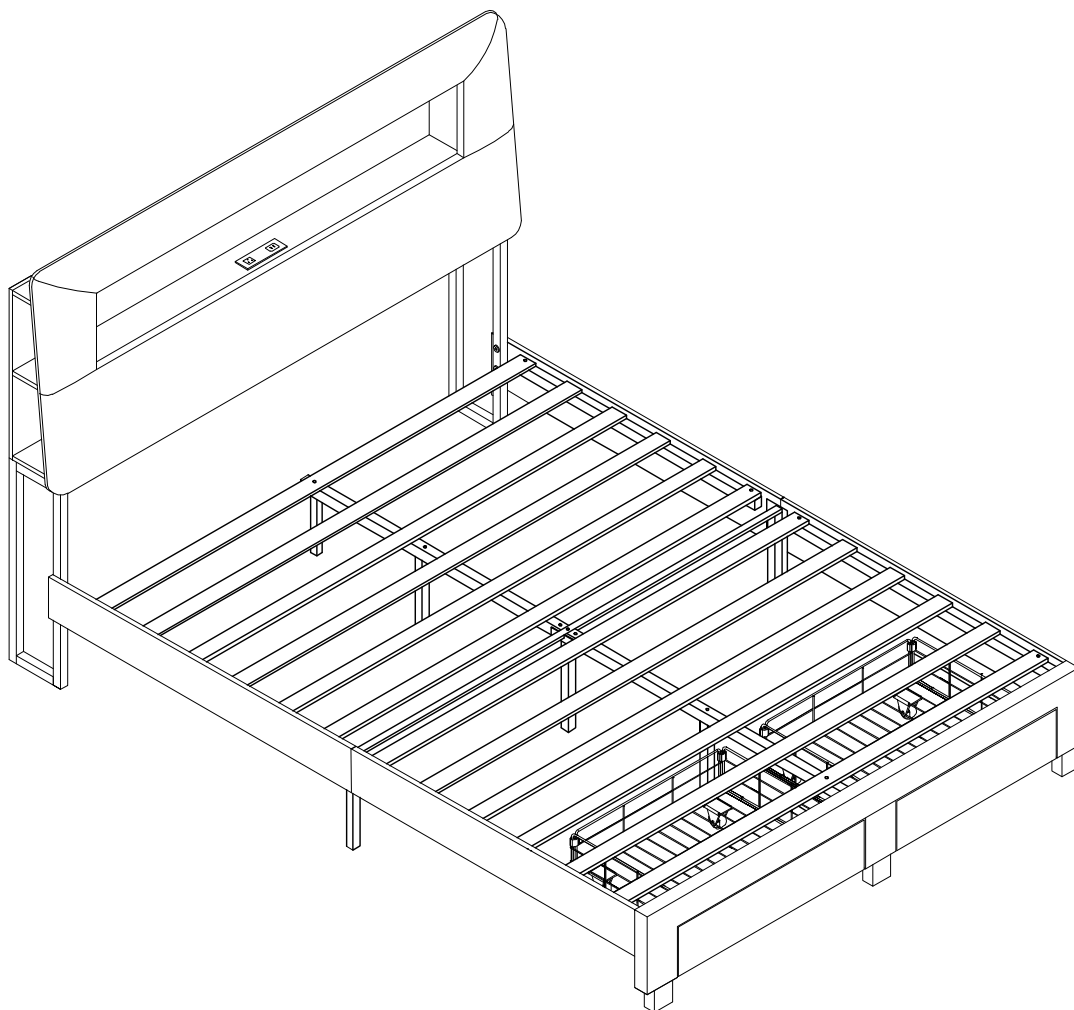





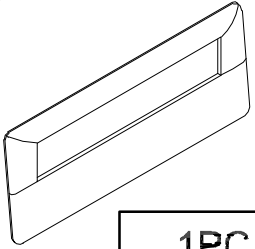
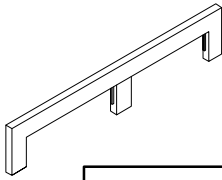
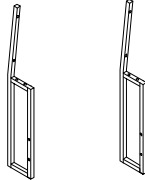
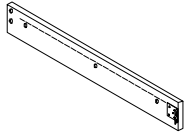
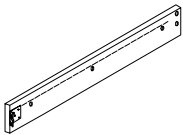
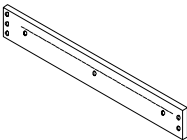
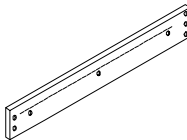
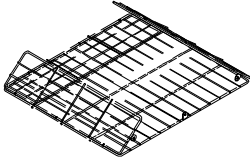
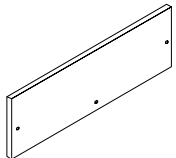
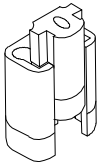
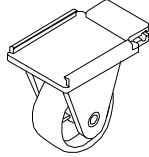
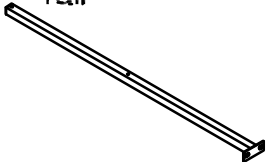
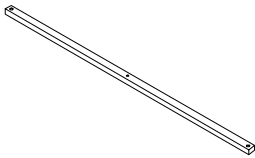
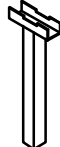
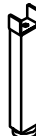

ASSEMBLY INSTRUCTION

BL-511

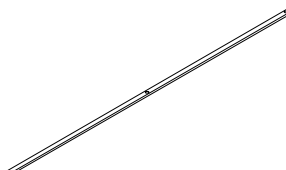

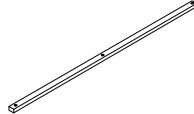
Upholstered Bed Frame
FULL/QUEEN SIZE

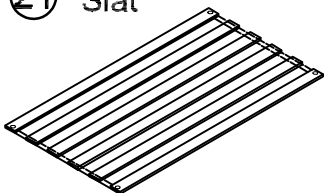

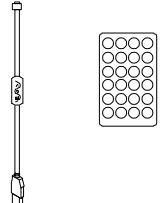
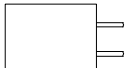



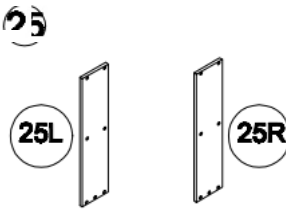
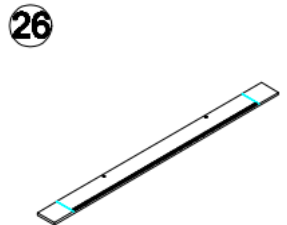
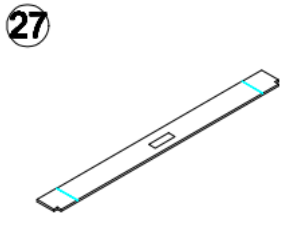
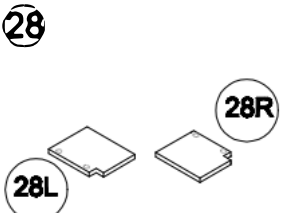
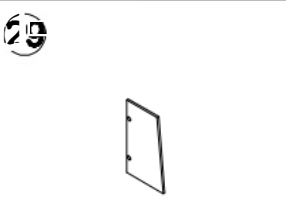
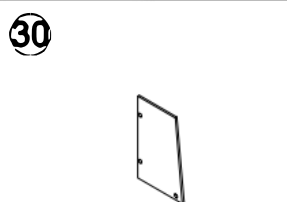
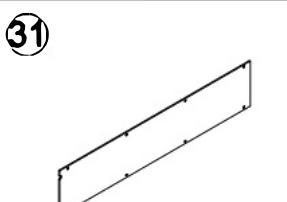
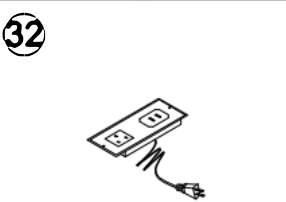



PARTS LIST

<p>① Headboard</p>  <p style="text-align: center; border: 1px solid black; padding: 2px;">1PC</p>	<p>② Footboard</p>  <p style="text-align: center; border: 1px solid black; padding: 2px;">1PC</p>	<p>③ HB Leg</p>  <p style="text-align: center; border: 1px solid black; padding: 2px;">2PCS</p>	<p>④ Side Rail (R)</p>  <p style="text-align: center; border: 1px solid black; padding: 2px;">1PC</p>
<p>⑤ Side Rail (L)</p>  <p style="text-align: center; border: 1px solid black; padding: 2px;">1PC</p>	<p>⑥ Side Rail (R)</p>  <p style="text-align: center; border: 1px solid black; padding: 2px;">1PC</p>	<p>⑦ Side Rail (L)</p>  <p style="text-align: center; border: 1px solid black; padding: 2px;">1PC</p>	<p>⑧ FB Drawer</p>  <p style="text-align: center; border: 1px solid black; padding: 2px;">2PCS</p>
<p>⑨ FB Drawer panel</p>  <p style="text-align: center; border: 1px solid black; padding: 2px;">2PCS</p>	<p>⑩ Drawer connector</p>  <p style="text-align: center; border: 1px solid black; padding: 2px;">4PCS</p>	<p>⑪ Drawer wheel</p>  <p style="text-align: center; border: 1px solid black; padding: 2px;">8PCS</p>	<p>⑫ Center support rail</p>  <p style="text-align: center; border: 1px solid black; padding: 2px;">1PC</p>
<p>⑬ Center support rail</p>  <p style="text-align: center; border: 1px solid black; padding: 2px;">1PC</p>	<p>⑭ Center Support Leg</p>  <p style="text-align: center; border: 1px solid black; padding: 2px;">1PC</p>	<p>⑮ Support Leg</p>  <p style="text-align: center; border: 1px solid black; padding: 2px;">3PCS</p>	<p>⑯ Side rail feet</p>  <p style="text-align: center; border: 1px solid black; padding: 2px;">2PCS</p>
<p>⑰ Center cross bar</p>  <p style="text-align: center; border: 1px solid black; padding: 2px;">1PC</p>	<p>⑱ ANGLE IRON</p>  <p style="text-align: center; border: 1px solid black; padding: 2px;">4PCS</p>	<p>⑲ Side rail support</p>  <p style="text-align: center; border: 1px solid black; padding: 2px;">4PCS</p>	<p>⑳ Bed Leg</p>  <p style="text-align: center; border: 1px solid black; padding: 2px;">3PCS</p>
<p>㉑ Slat</p>  <p style="text-align: center; border: 1px solid black; padding: 2px;">2SET</p>	<p>㉒ LED light belt</p>  <p style="text-align: center; border: 1px solid black; padding: 2px;">1PC</p>	<p>㉓ Remote control</p>  <p style="text-align: center; border: 1px solid black; padding: 2px;">1SET</p>	<p>㉔ POWER</p>  <p style="text-align: center; border: 1px solid black; padding: 2px;">1PC</p>

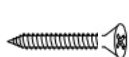
PARTS LIST

 <p style="text-align: center;">25</p> <p style="text-align: center;">25L 25R</p> <p style="text-align: center;">2PCS</p>	 <p style="text-align: center;">26</p> <p style="text-align: center;">1PC</p>	 <p style="text-align: center;">27</p> <p style="text-align: center;">1PC</p>	 <p style="text-align: center;">28</p> <p style="text-align: center;">28L 28R</p> <p style="text-align: center;">2PCS</p>
 <p style="text-align: center;">29</p> <p style="text-align: center;">2PCS</p>	 <p style="text-align: center;">30</p> <p style="text-align: center;">2PCS</p>	 <p style="text-align: center;">31</p> <p style="text-align: center;">1PC</p>	 <p style="text-align: center;">32</p> <p style="text-align: center;">1PC</p>

HARDWARE LIST

<p>A Screw</p>  <p>5/16**40mm 15+2PCS</p>	<p>B Screw</p>  <p>5/16**25mm 6+1PCS</p>	<p>C Screw</p>  <p>1/4**15mm 26+2PCS</p>	<p>D Screw</p>  <p>1/4**38mm 20+2PCS</p>
<p>E Screw</p>  <p>M3*15mm 2PCS</p>	<p>F Lock Washer</p>  <p>5/16**13mm 21+2PCS</p>	<p>G Flat Washer</p>  <p>5/16**19mm 21+2PCS</p>	<p>H Flat Washer</p>  <p>1/4**16mm 46+2PCS</p>
<p>I Screw</p>  <p>M4*35mm 40+2PCS</p>	<p>J Inner allen wrench</p>  <p>5/16**100mm 1PC</p>	<p>K Inner allen wrench</p>  <p>M4*65mm 1PC</p>	

Assembly Steps

STEP 1:

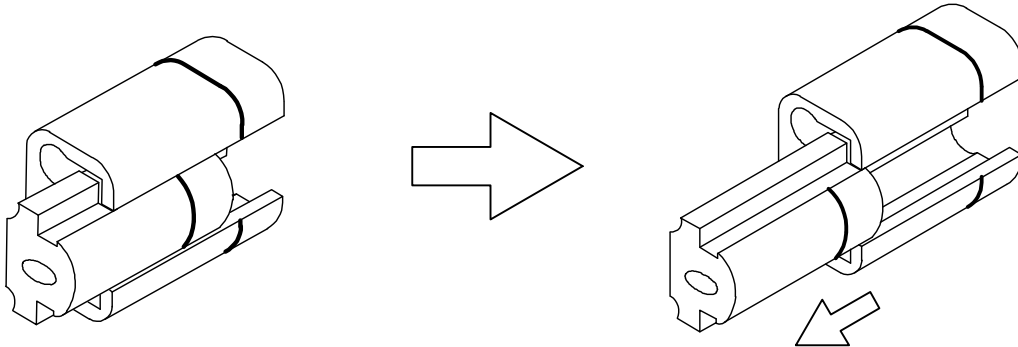

You can pull the buckle out by following the direction indicated by the arrow

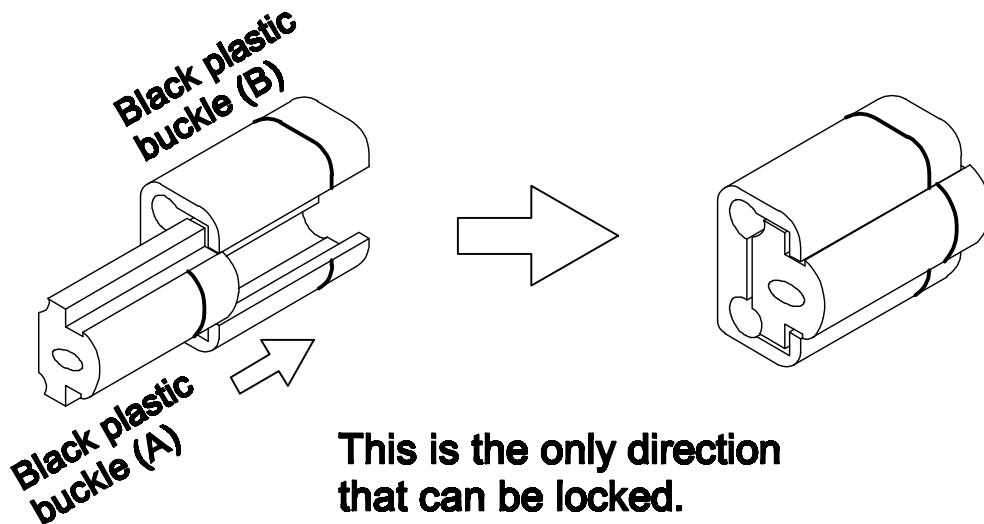

This is the only direction that can be locked.

STEP 2:

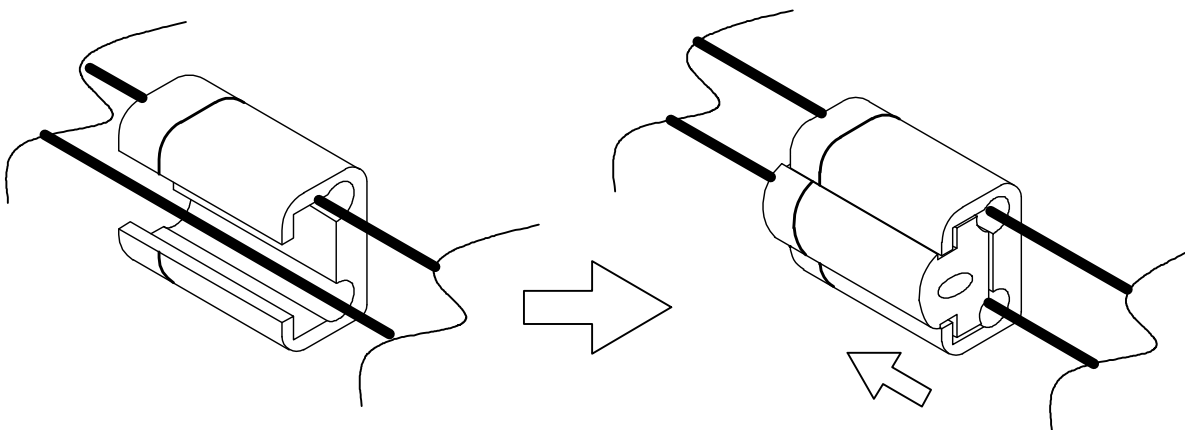

Place round iron tube as shown for better drawer assembly

Assembly Steps

STEP 3:

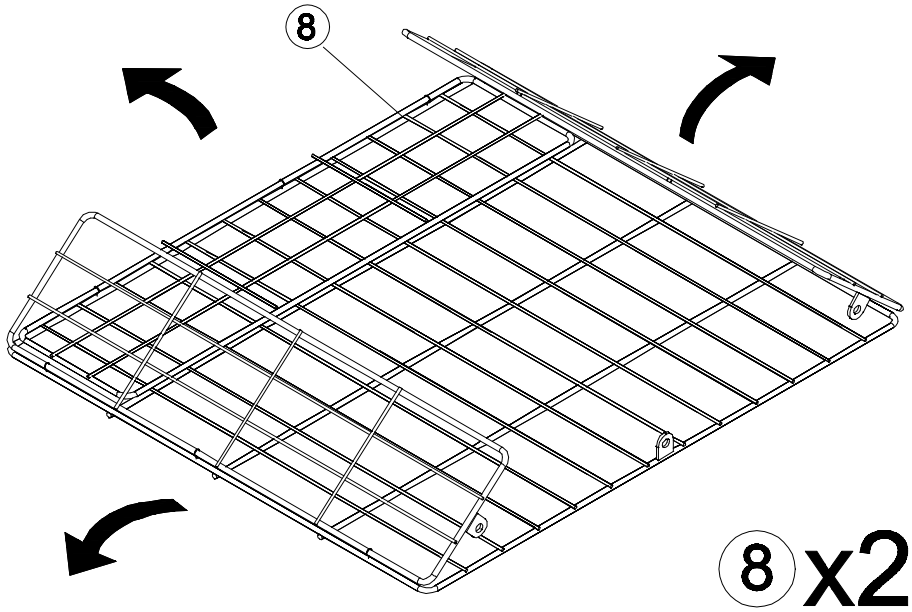

STEP 4:

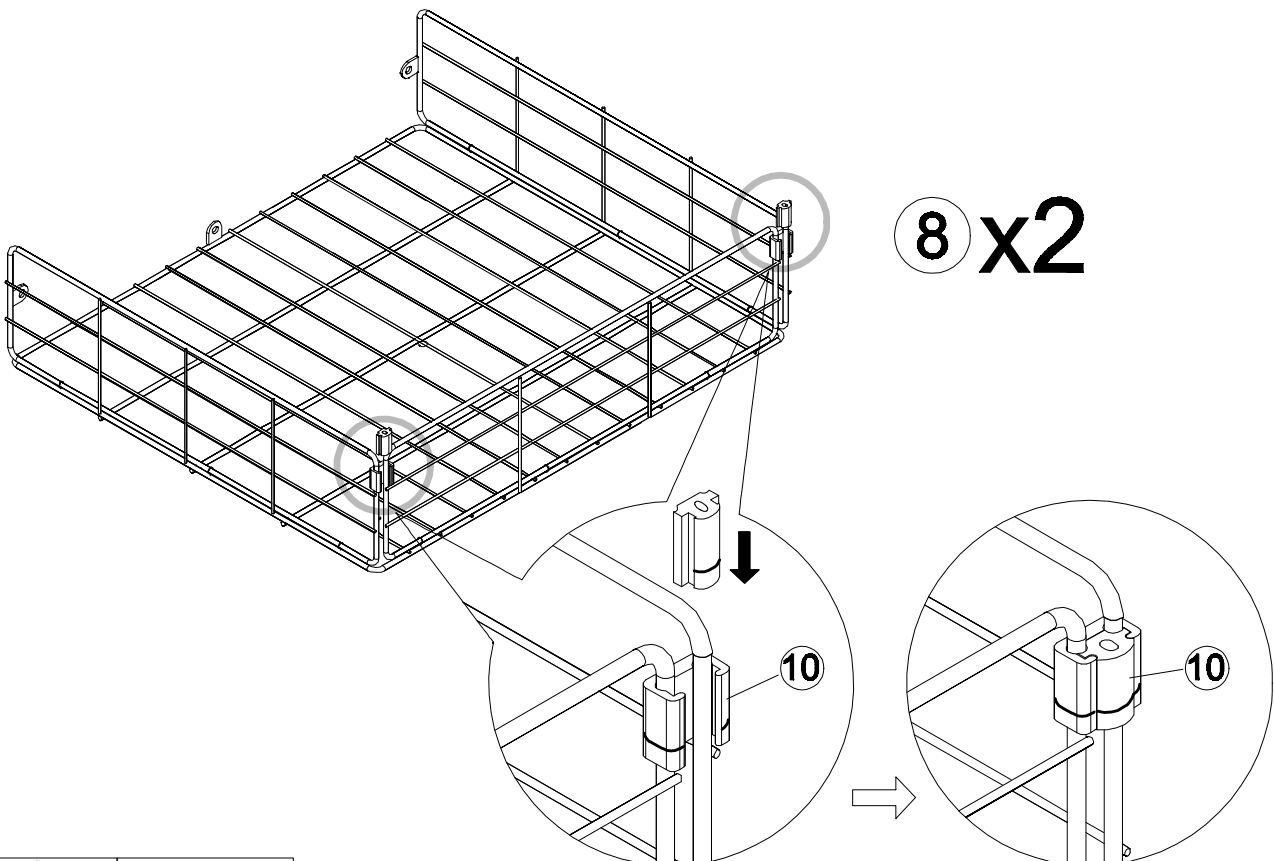

10 x 4PCS

Assembly Steps

STEP 5:

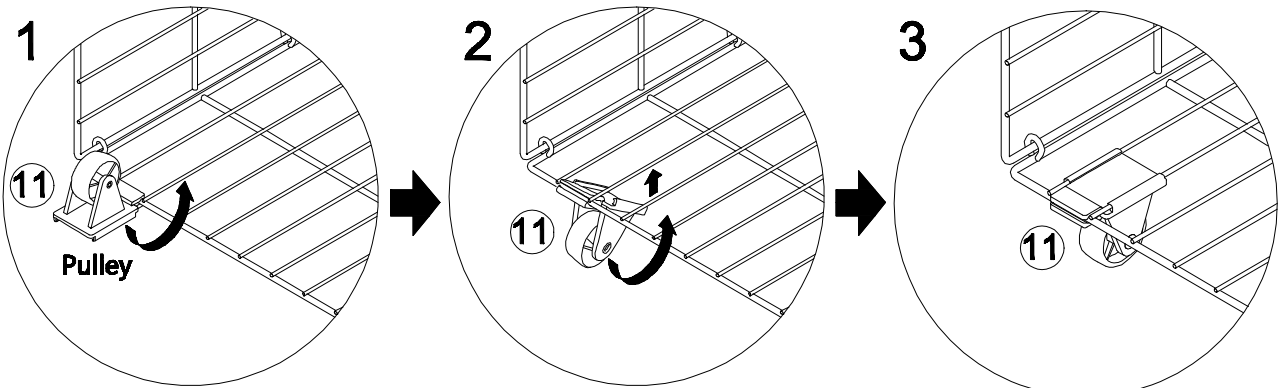

1. As shown in the figure Clip the pulley into position first

2. Then push the pulley to the side, clamp the iron wire at the edge.

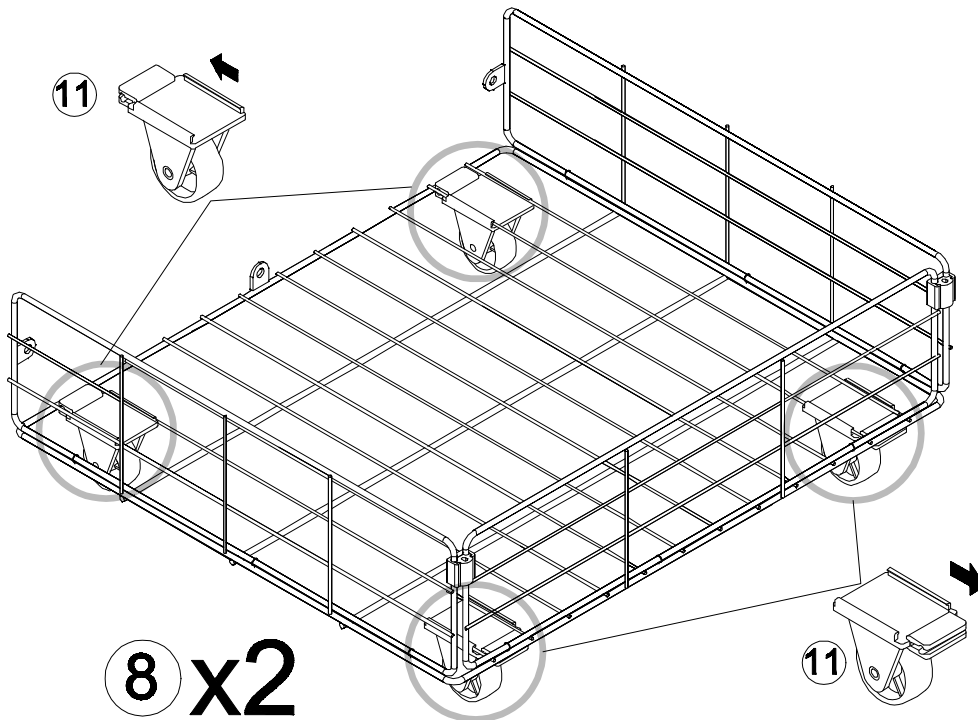

Place the round iron tubes as shown for better assembly of the drawers.





11 x 8PCS

Assembly Steps

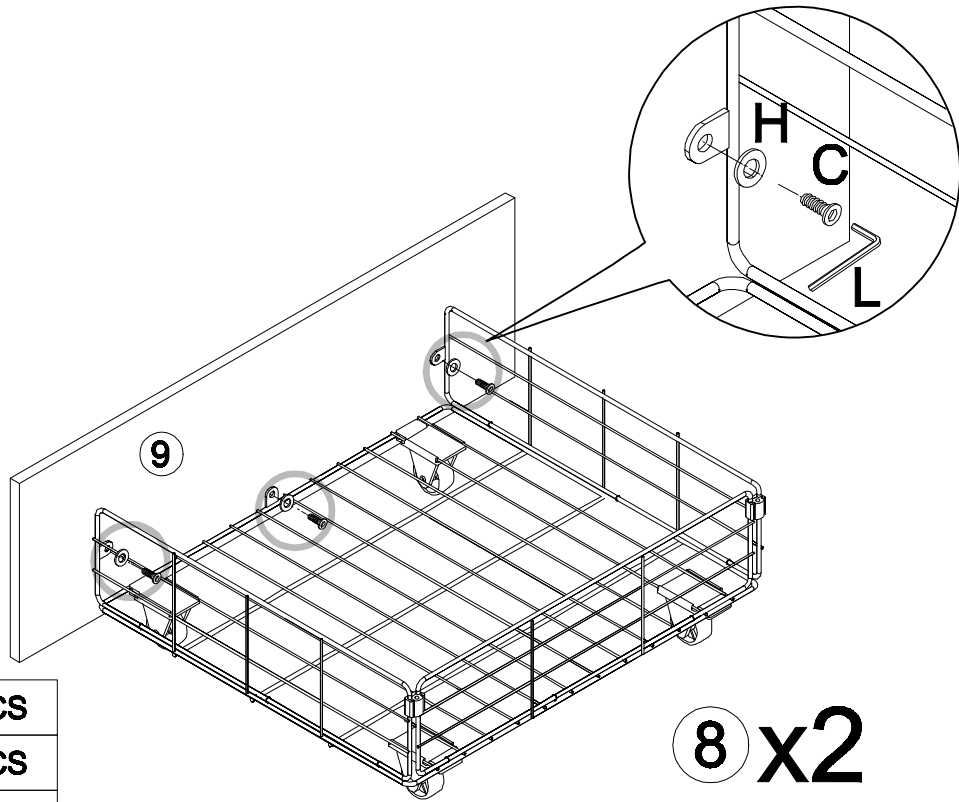
STEP 6:



	Cx 6PCS
	Hx 6PCS
	Kx 1PC

STEP 7:

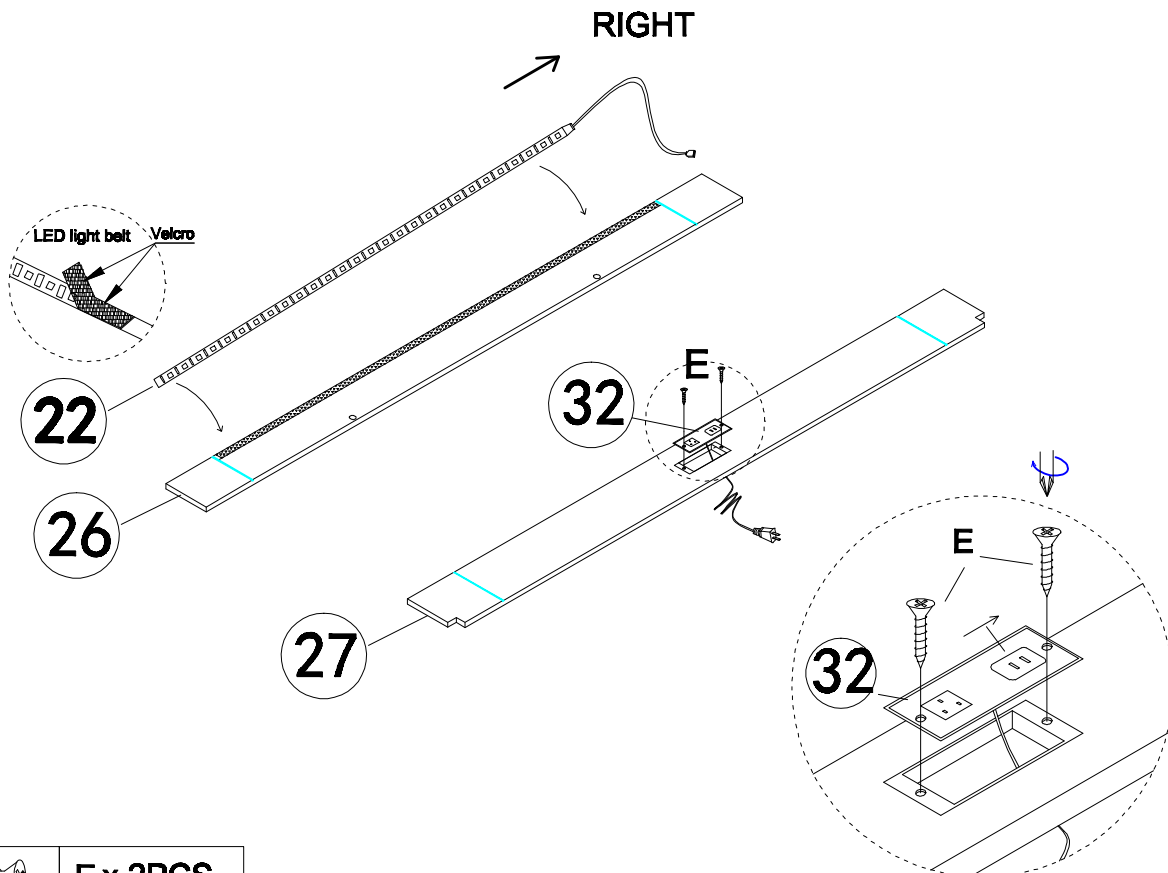

	E x 2PCS
---	-----------------

Assembly Steps

STEP 8:

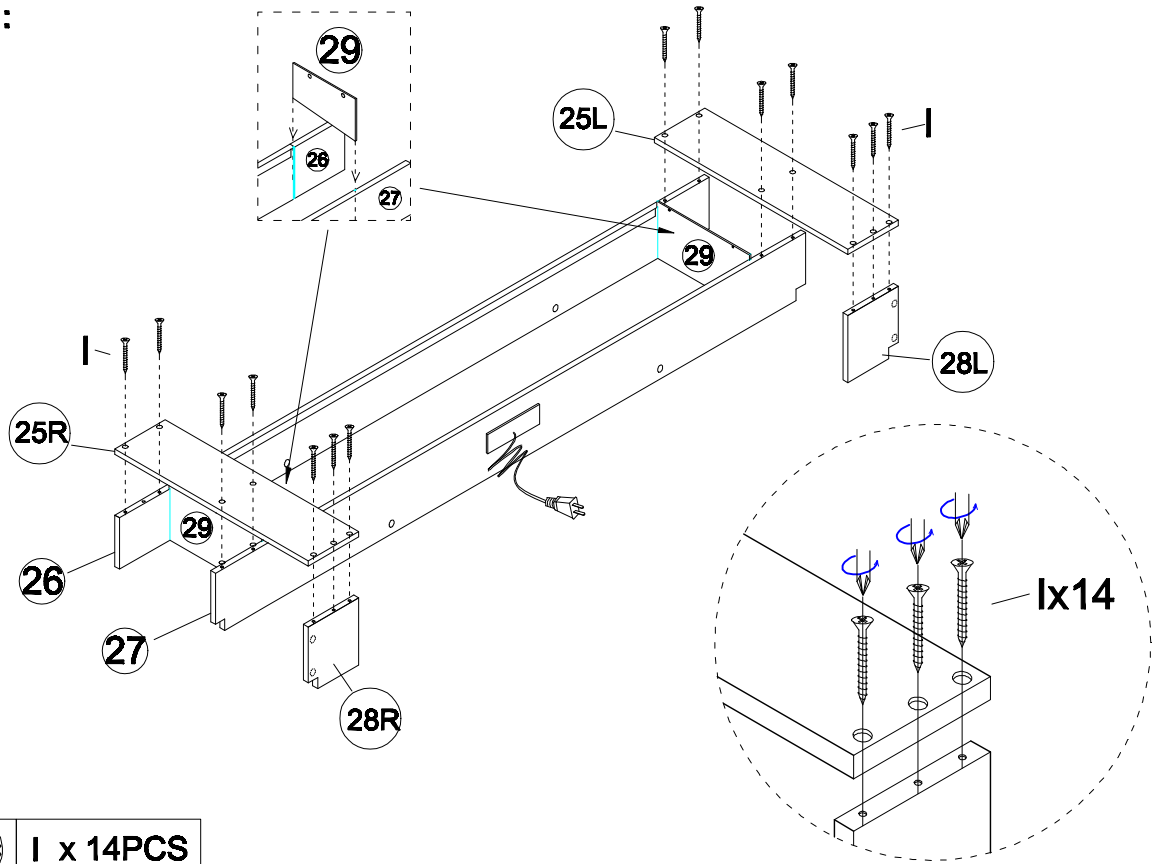

 1 x 14PCS

STEP 9:

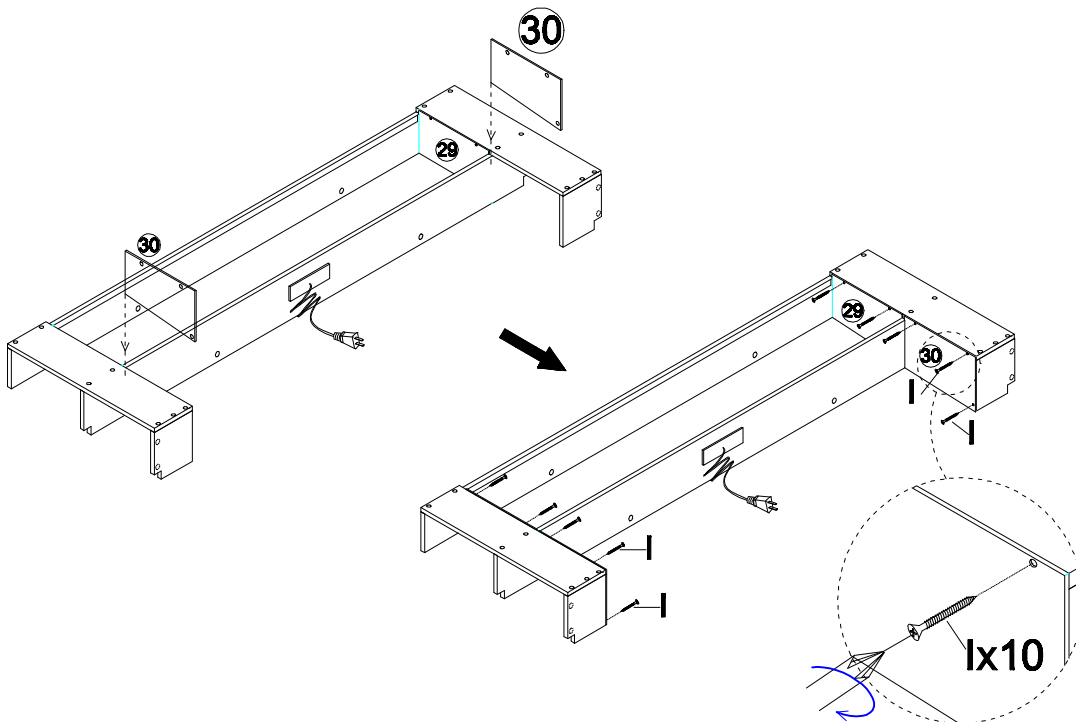



 1 x 10PCS

Assembly Steps

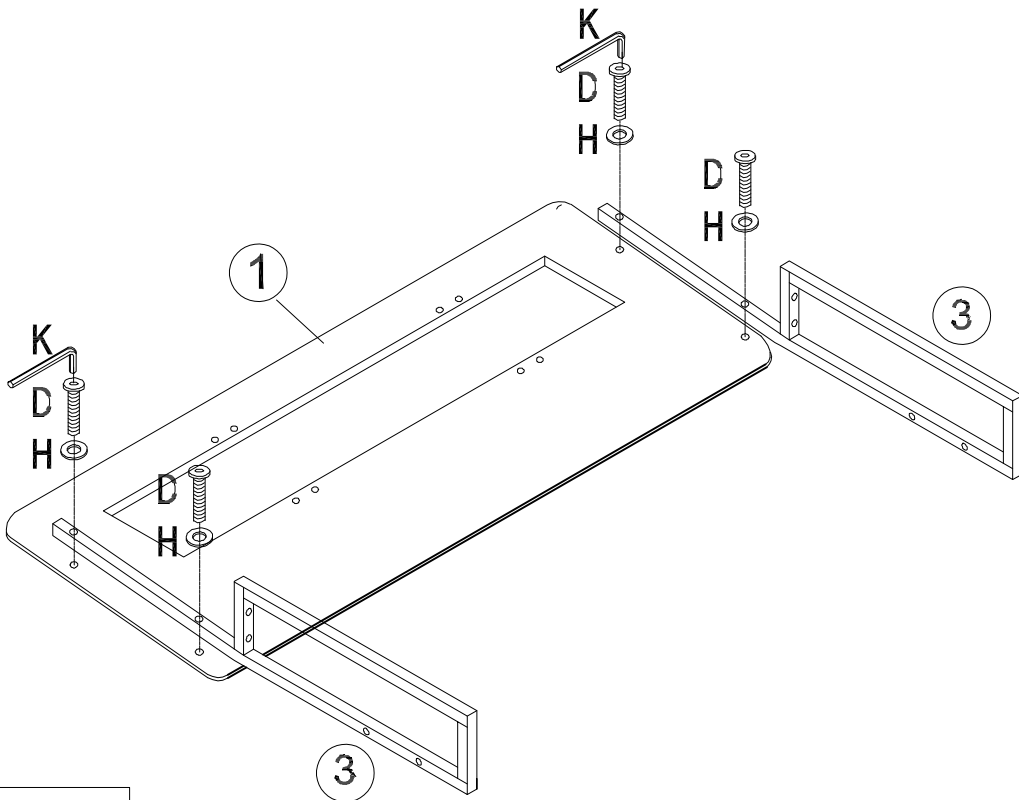



STEP 10:

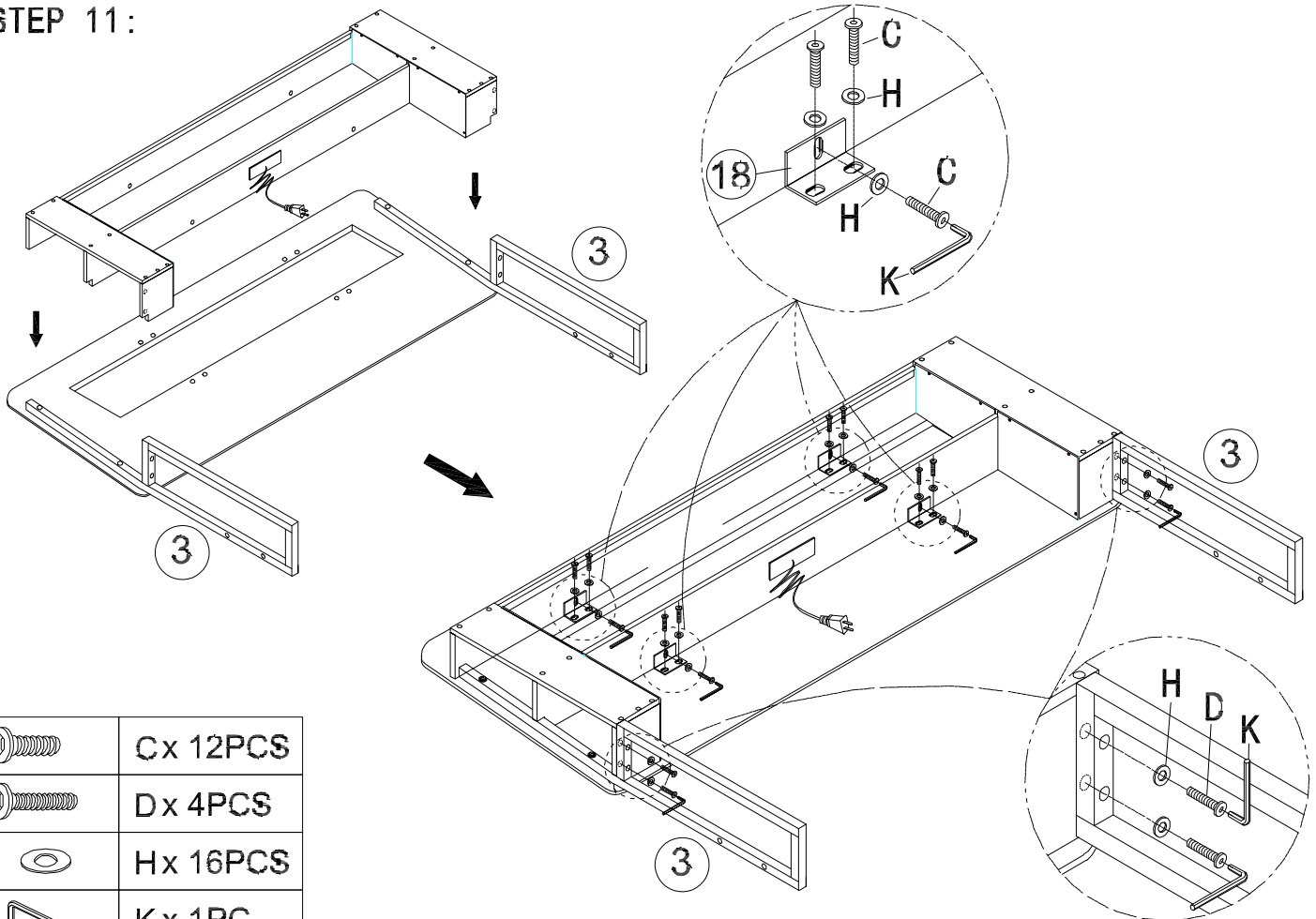

	Dx 4PCS
	Hx 4PCS
	Kx 1PC

STEP 11:



	Cx 12PCS
	Dx 4PCS
	Hx 16PCS
	Kx 1PC

Assembly Steps

STEP 12:

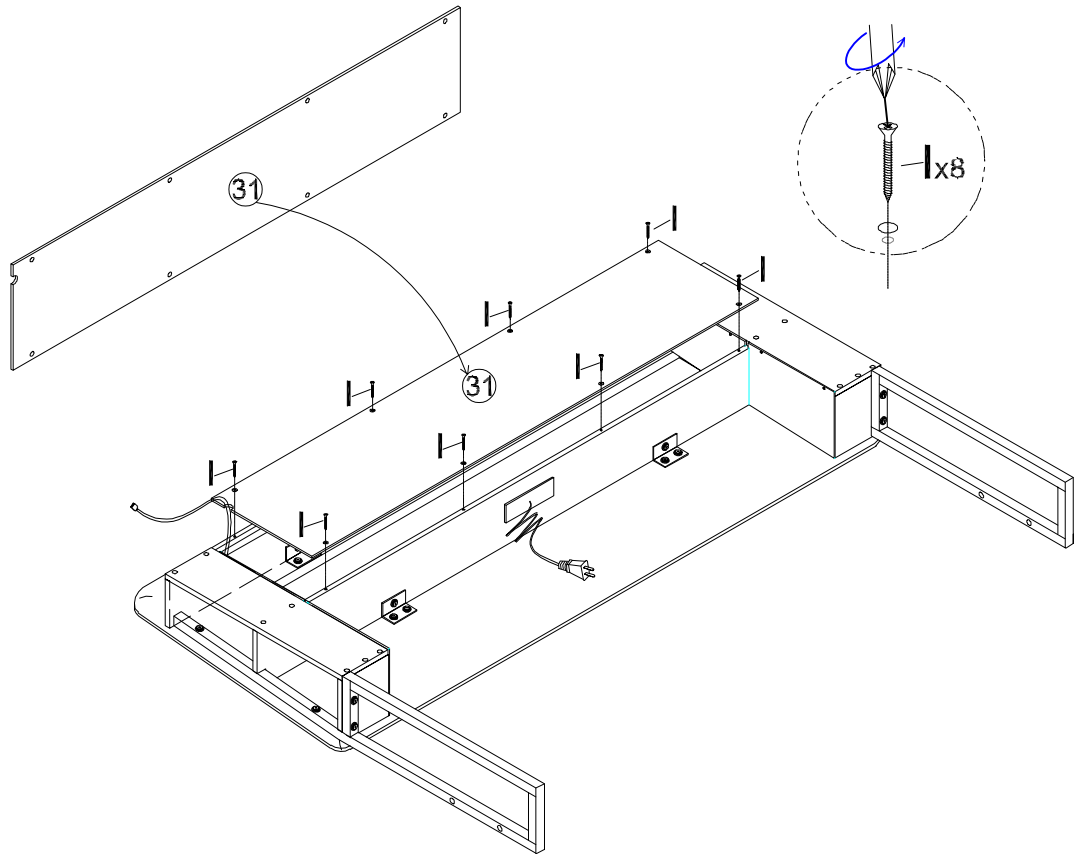

1 x 8PCS



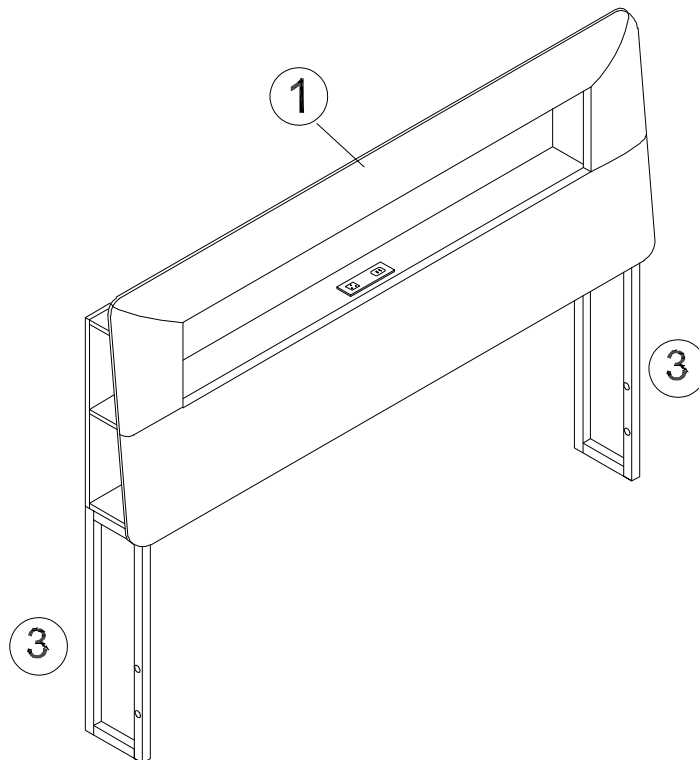

STEP 13:

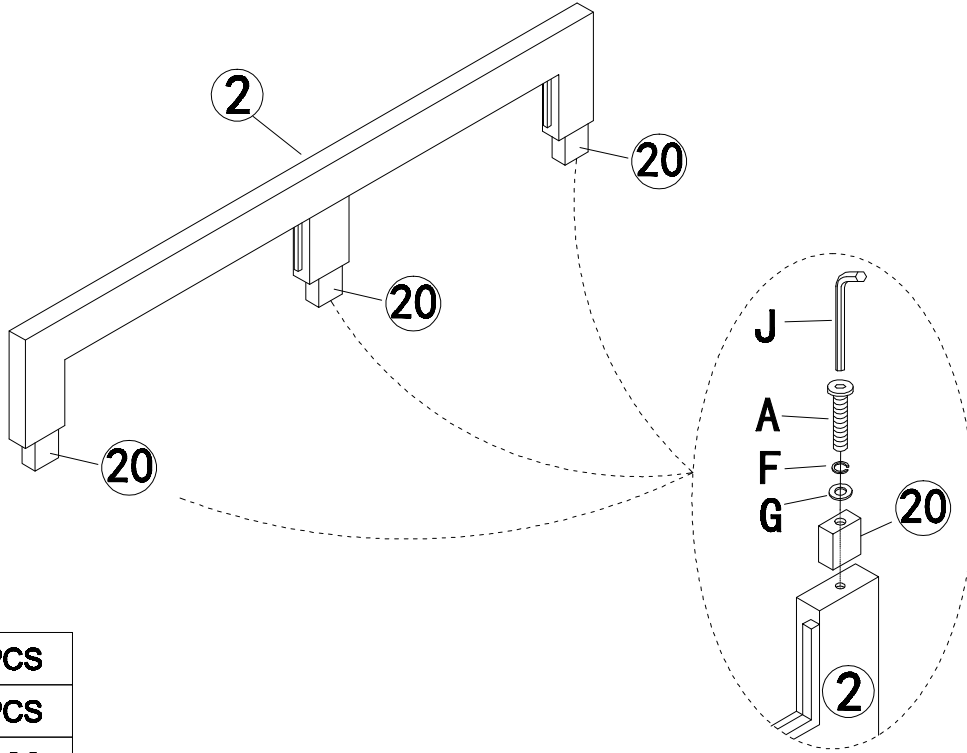

Assembly Steps



STEP 14:

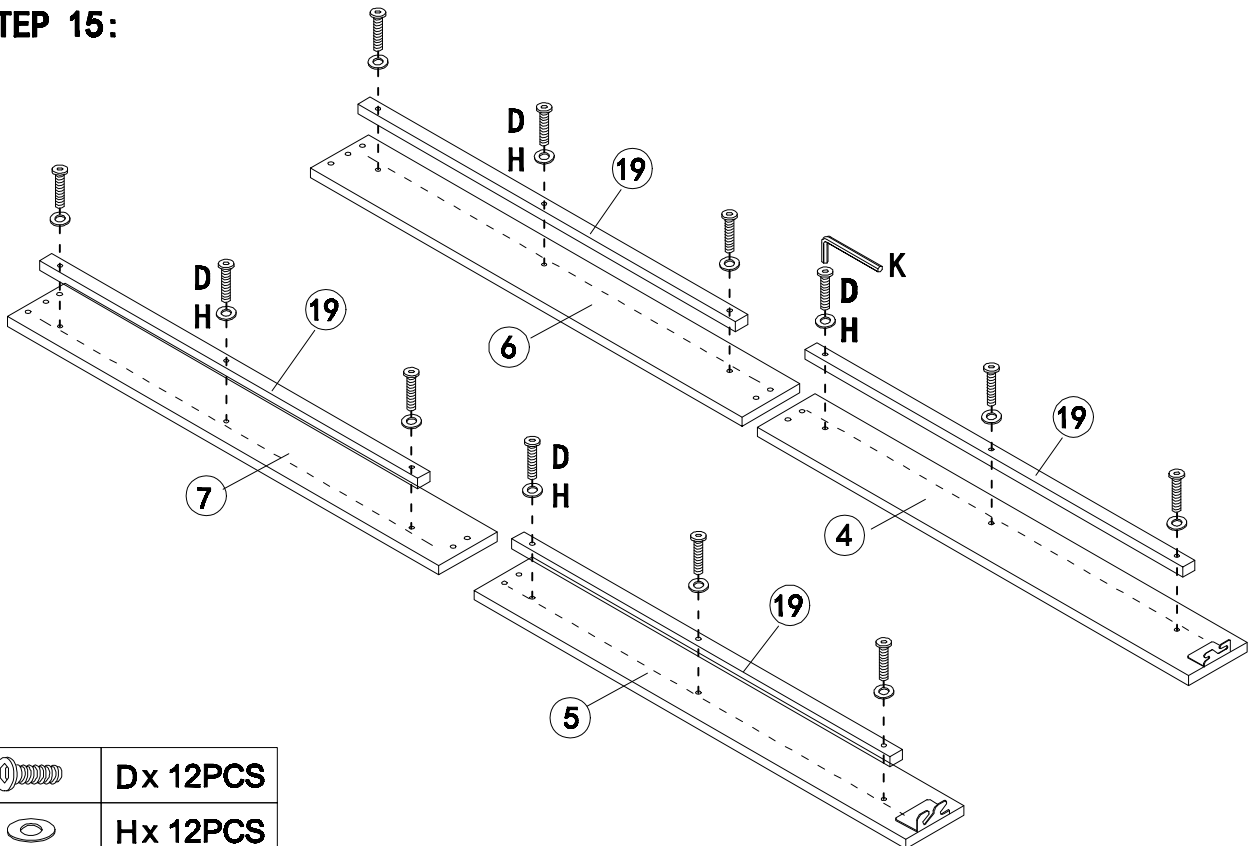

	A x 3PCS
	F x 3PCS
	G x 3PCS
	J x 1PC

STEP 15:





	D x 12PCS
	H x 12PCS
	K x 1PC

Assembly Steps

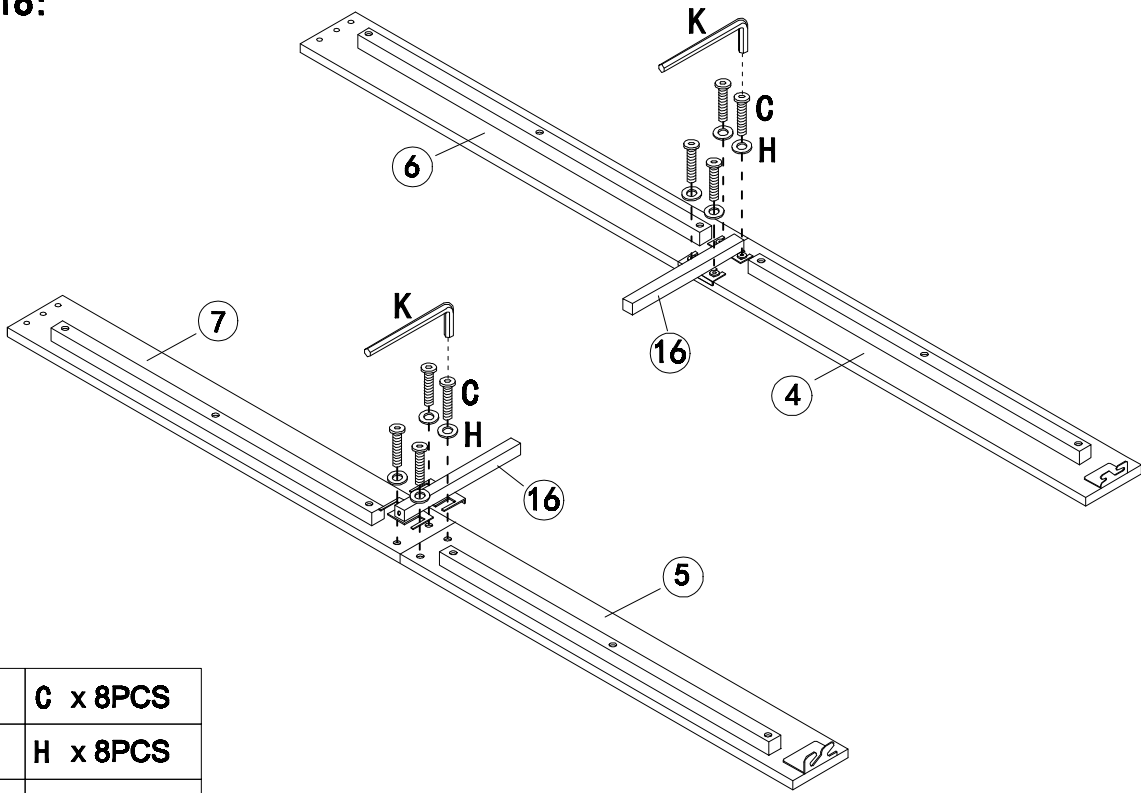



STEP 16:

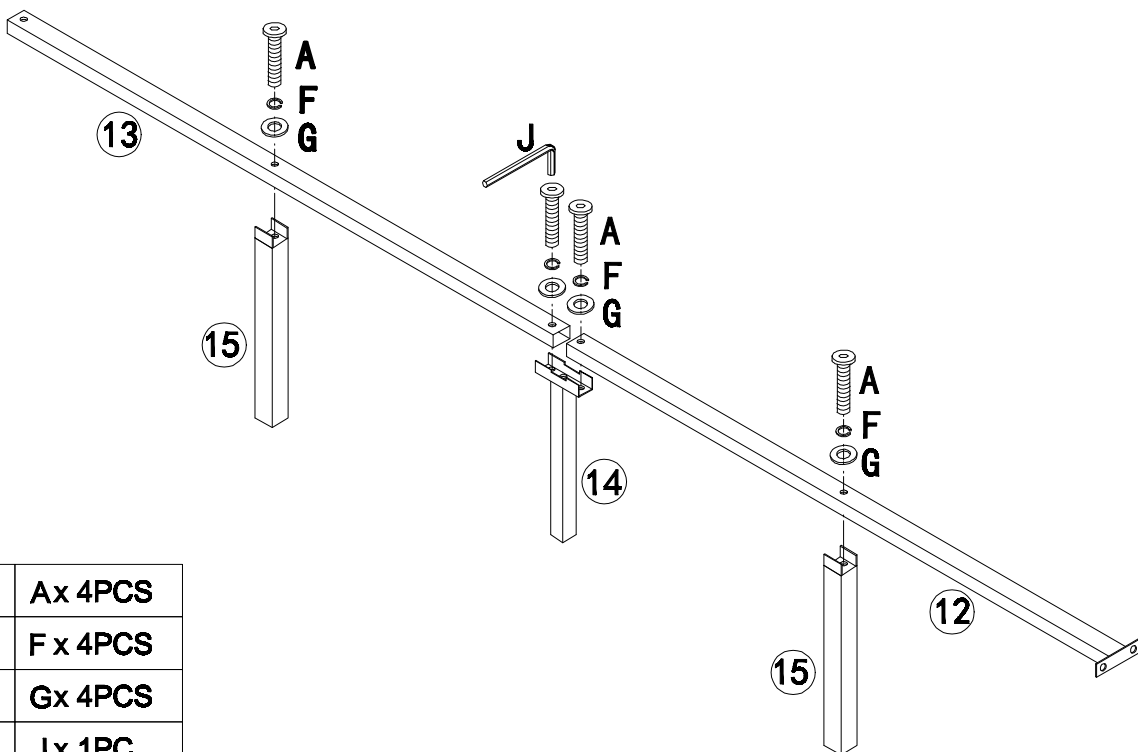

	C x 8PCS
	H x 8PCS
	K x 1PC

STEP 17:





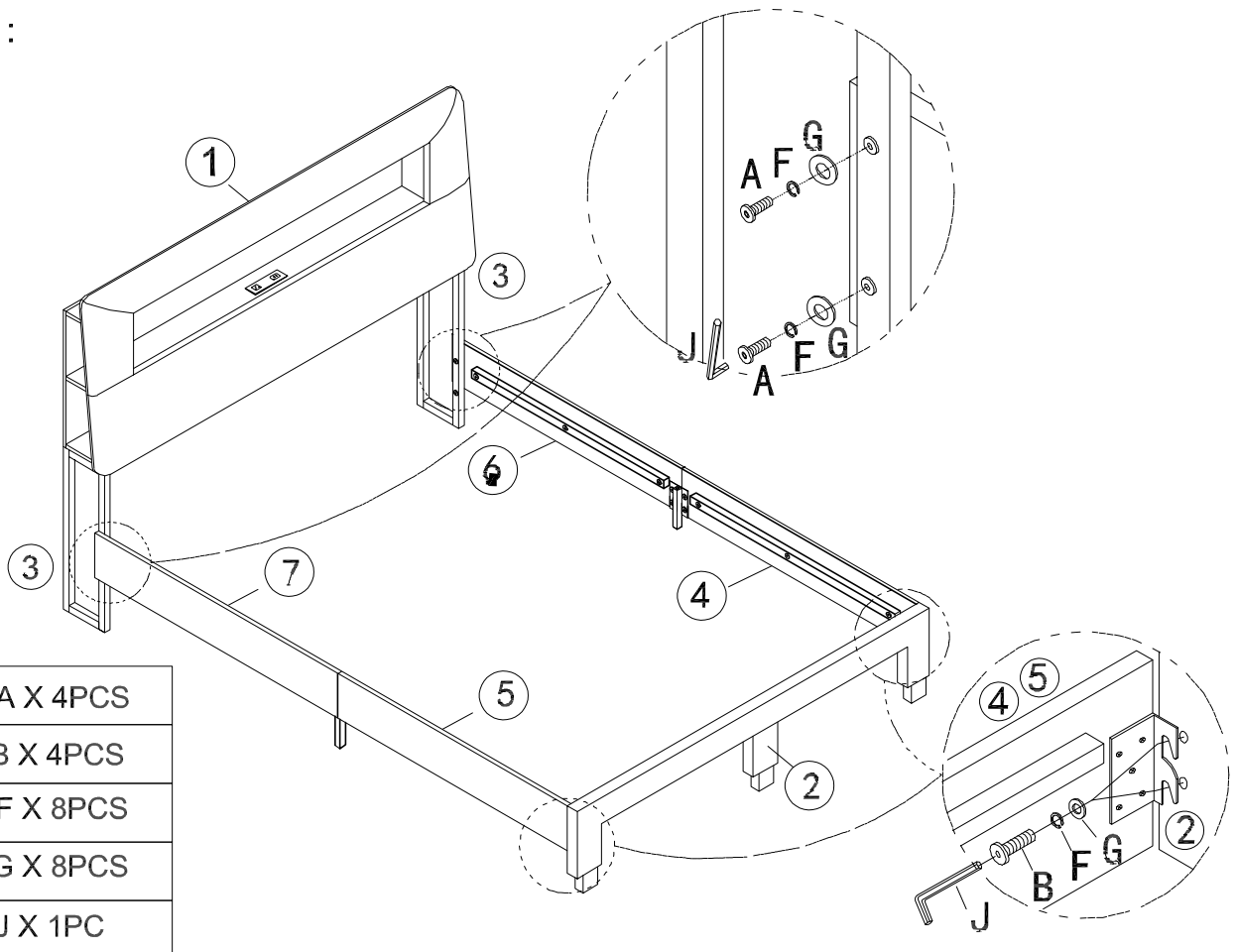

	A x 4PCS
	F x 4PCS
	G x 4PCS
	J x 1PC

Assembly Steps





STEP 18:

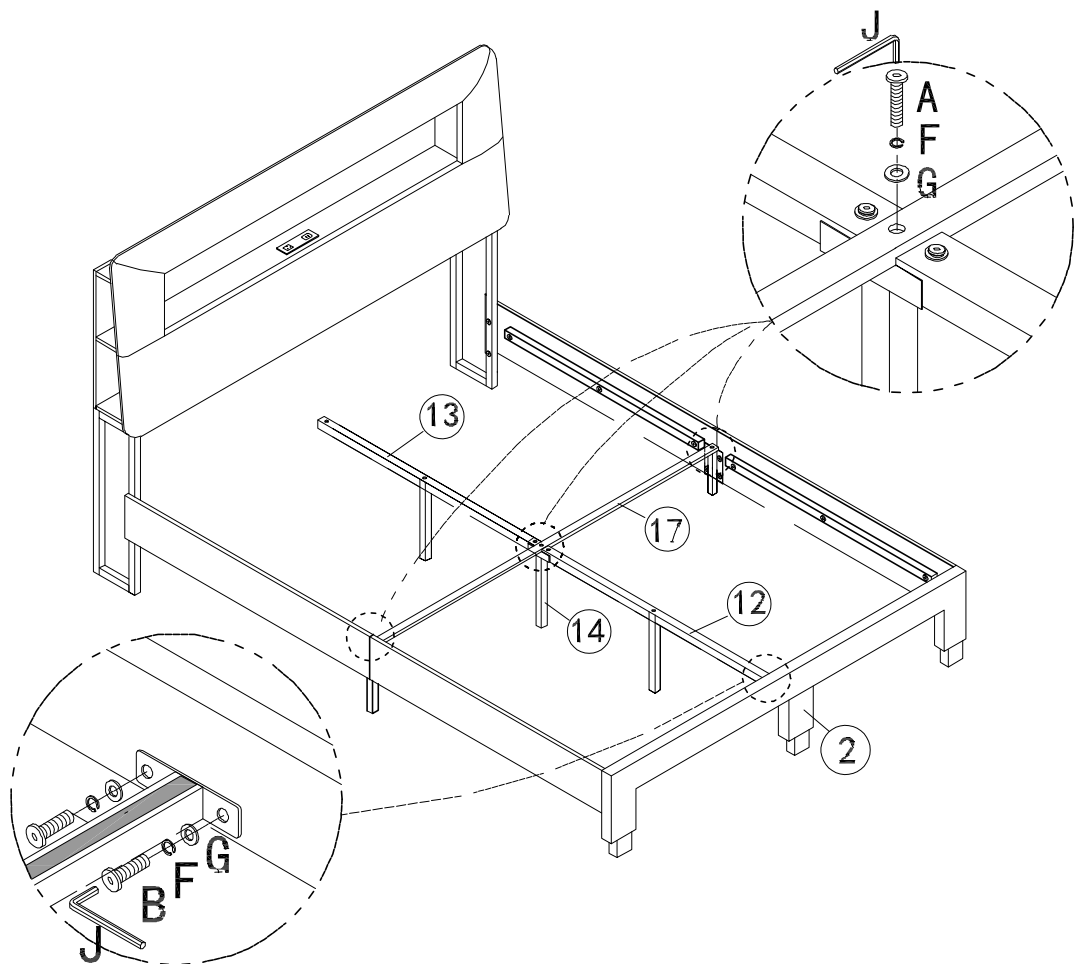

	A X 4PCS
	B X 4PCS
	F X 8PCS
	G X 8PCS
	J X 1PC

STEP 19:



	A x 3PCS
	B x 2PCS
	F x 5PCS
	G x 5PCS
	J x 1PC



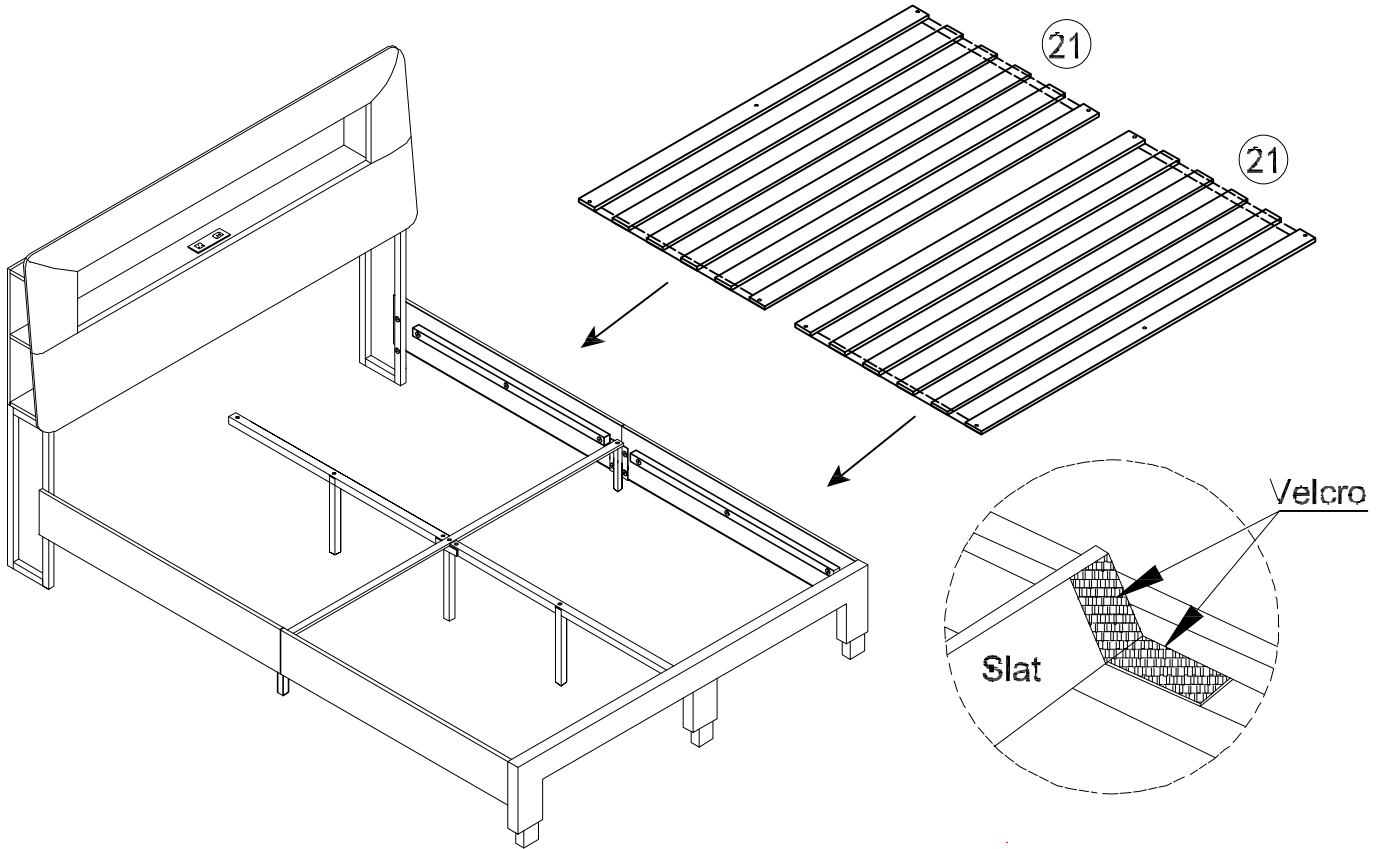

Assembly Steps

STEP 20:

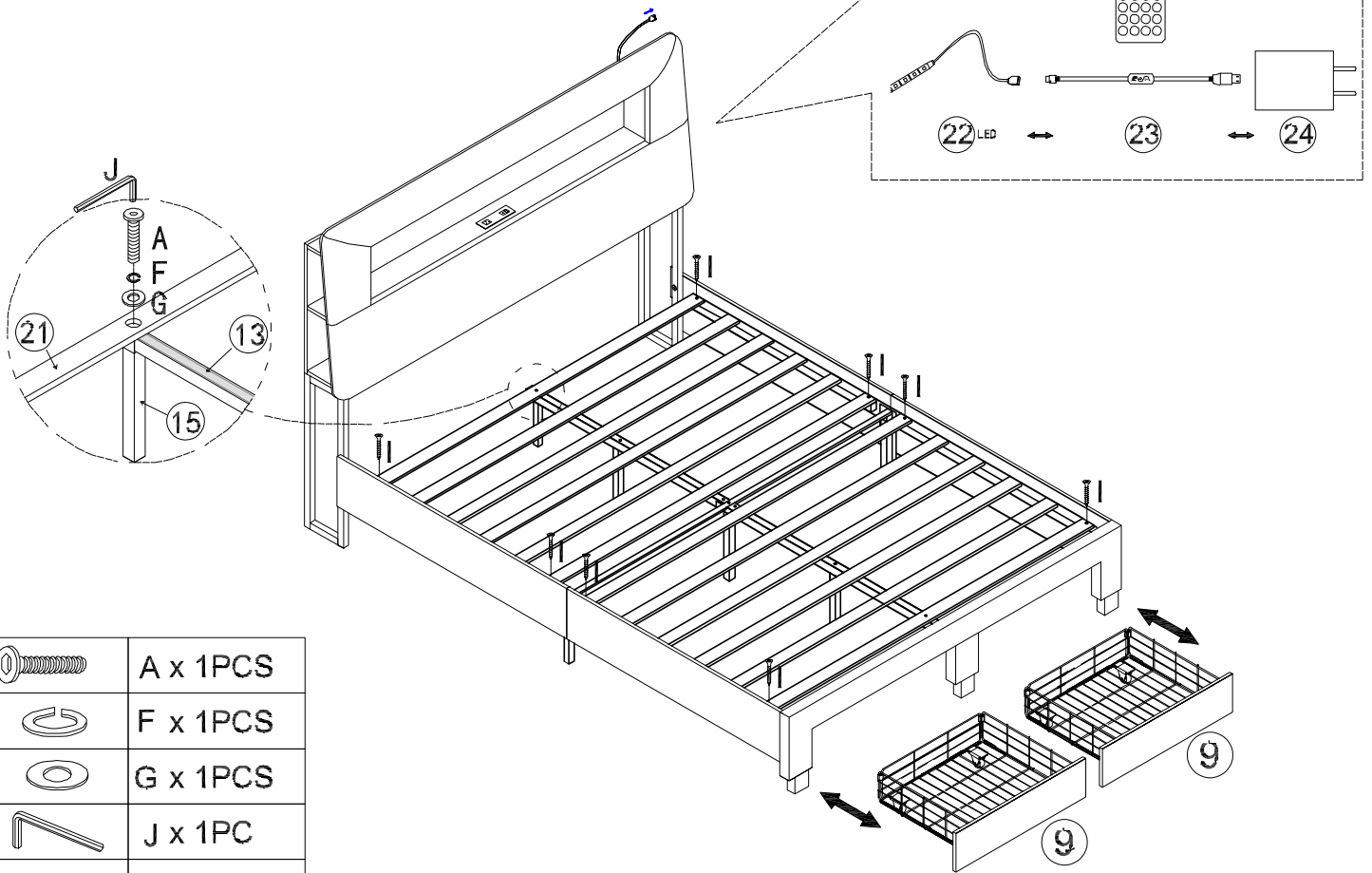

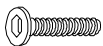
STEP 21:



	A x 1PCS
	F x 1PCS
	G x 1PCS
	J x 1PC
	I x 8PCS