

MONTAGEANLEITUNG

Artikelnummer: WF315421WAA
WF315422WAA
WF315423WAA
WF315424WAA

Unser Bett wird in 4 Paketen geliefert. Die Lieferzeit dieser 4 Pakete können abweichen. bittehaben Sie etwas Geduld und vielen Dank furlhr Verstandnis.

Our bed will be sent to you in four packages. The delivery time of these four parcels may be different. Please be patient. Thank you for your understanding.

BETT 90x200cm

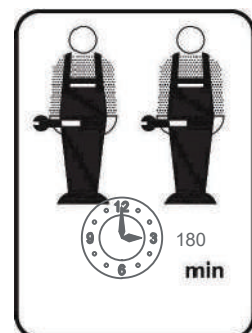
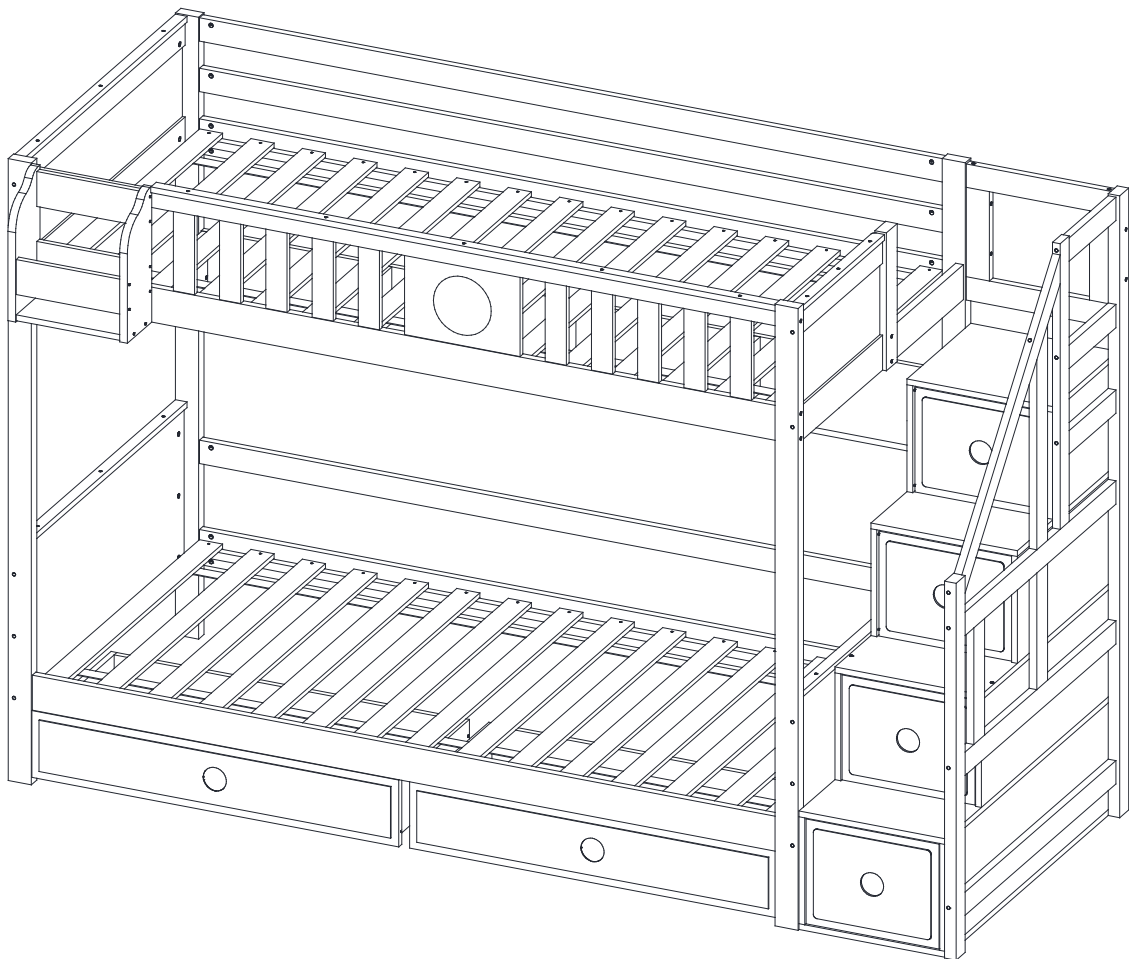

ANLEITUNGEN

WICHTIG - SORGFÄLTIG LESEN - FÜR SPÄTERE VERWENDUNG AUF BEWAHREN

- a) **WARNUNG** - Kinder können zwischen dem Bett und der Wand, den angrenzenden Möbelstücken (z. B. Schränken) und der Lücke eingeklemmt werden. Um die Gefahr schwerer Verletzungen zu vermeiden, darf der Abstand zwischen der Sicherheitsbarriere und der angrenzenden Struktur nicht mehr als 75 mm oder mehr als 230 mm betragen.
- b) **WARNUNG**-Das Bett darf nicht benutzt werden, wenn ein Bauteil gebrochen ist oder fehlt; Ersatzteile sind beim Hersteller oder im Geschäft anzufordern.
- c) **WARNUNG** - Klettern oder wackeln Sie nicht auf nicht dafür vorgesehenen Strukturen.
- d) Befolgen Sie unbedingt die Installationsanweisungen und die Gebrauchsanweisungen des Herstellers.
- e) Die empfohlene Größe der Matratze für das Bett beträgt 90x200cm, maximale Dicke der Matratze: 12cm.
- f) Es ist notwendig, den Raum zu lüften, um die Feuchtigkeit niedrig zu halten und Schimmelbildung im Bett und seiner Umgebung zu verhindern.
- g) Die Verbindungselemente sollten immer richtig angezogen sein und regelmäßig überprüft werden. Ziehen Sie sie gegebenenfalls nach.

INSTRUCTIONS

IMPORTANT-READ CAREFULLY-RETAIN FOR FUTURE REFERENCE

- a) **WARNING** -Children can become trapped between the bed and the wall, the adjoining pieces of furniture (e.g. cupboards) and the Ikea. To avoid risk of serious injury the distance between the safety barrier and the adjoining structure shall not exceed 75 mm or shall be more than 230 mm.
- b) **WARNING**-Do not use the bed if any structural part is broken or missing; Replacement parts are between requested from the manufacturer or the store.
- c) **WARNING**-Do not climb or wiggle on any non-designated structures.
- d) it is imperative to always follow the installation instructions and manufacturer's use.
- e) The recommended size of the mattress to be used with the bed is 90cmx-200cm,maximum thickness mattress:12cm.
- f) It is necessary to ventilate the room in order to maintain a low level moisture and prevent mold growth in the bed and its periphery.
- g) Joining devices should always be tightened properly and regularly verified. Tighten if necessary.



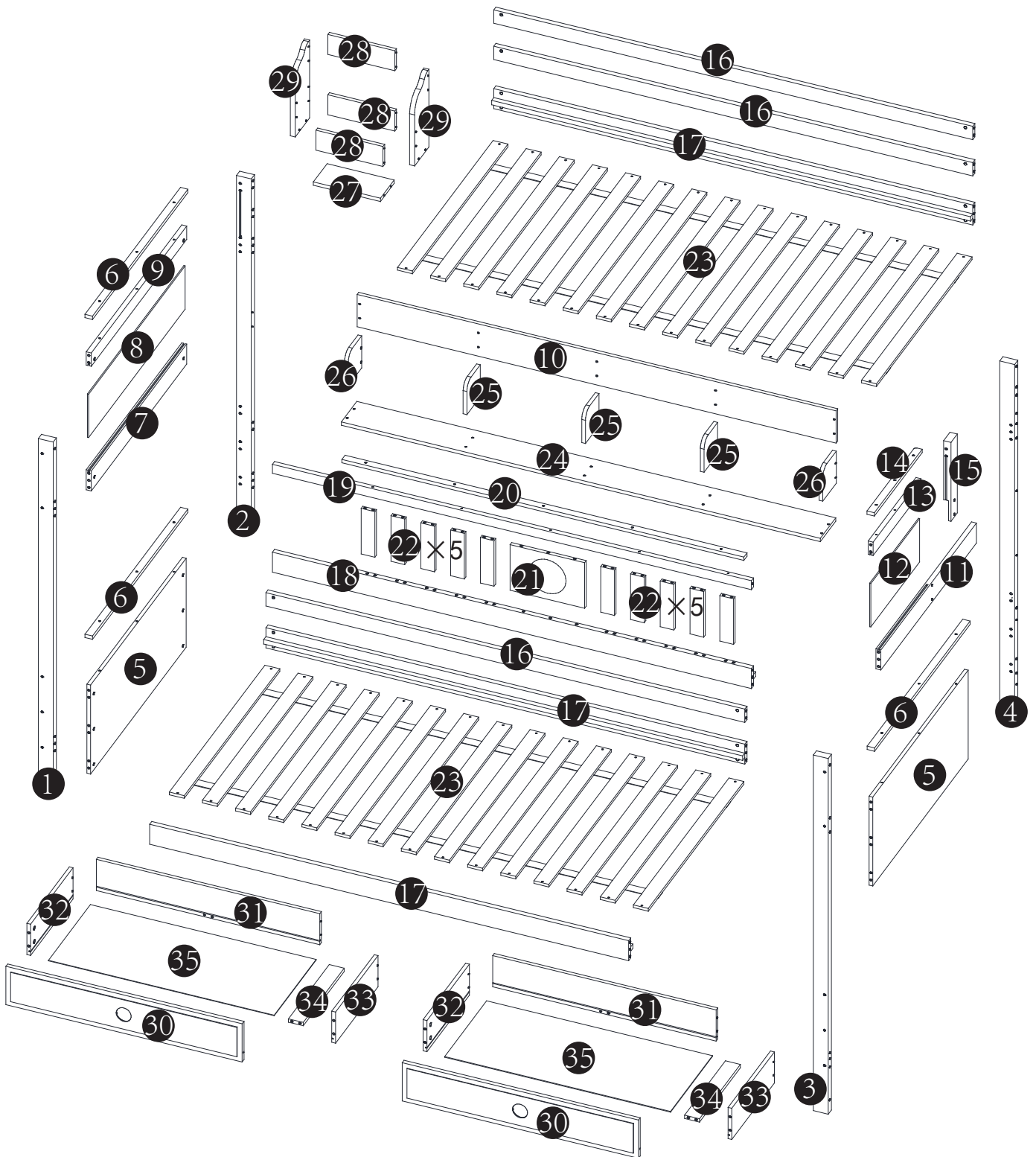

Stückliste 1/2

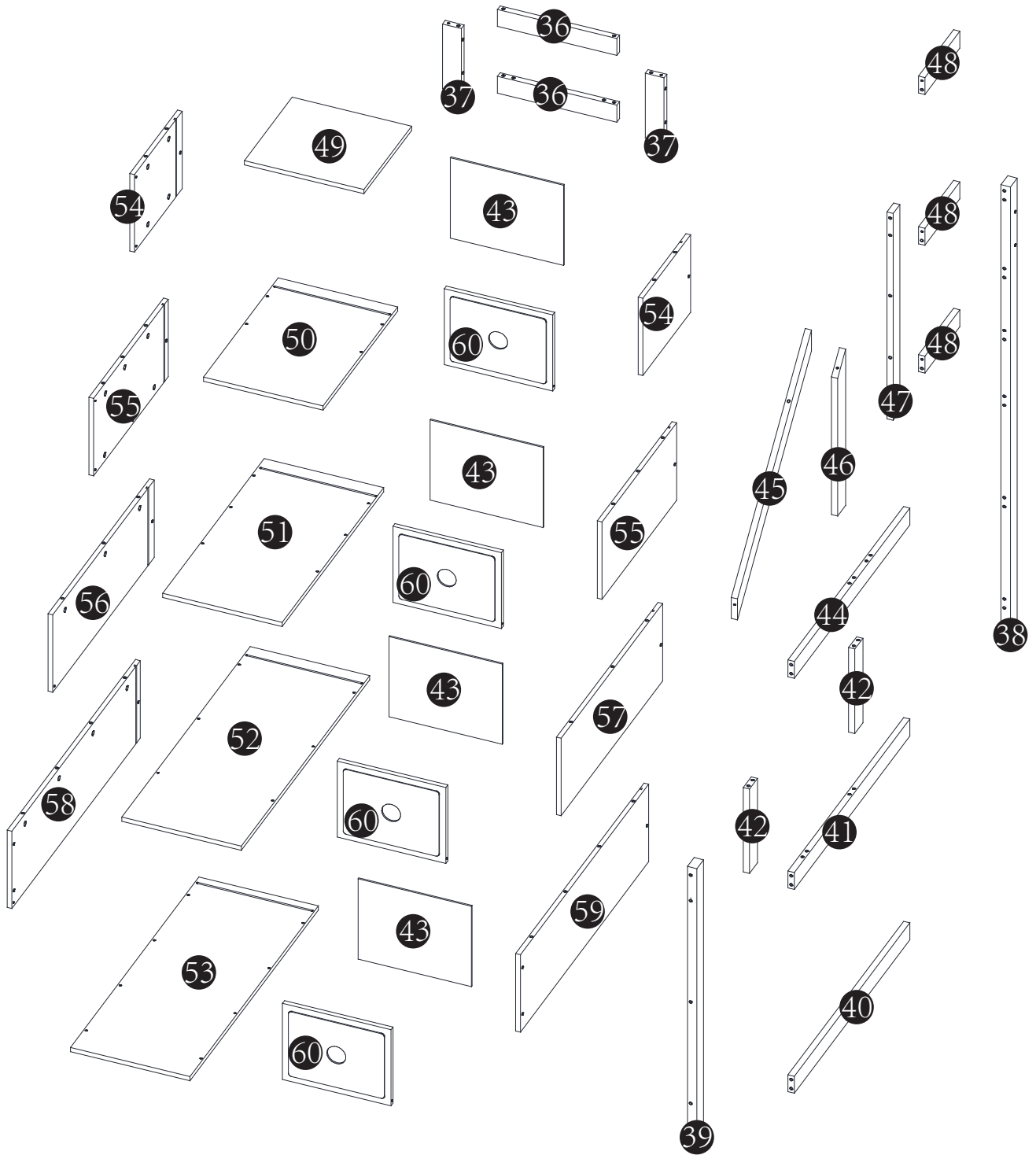



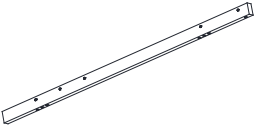
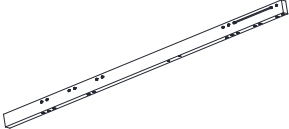
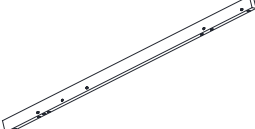
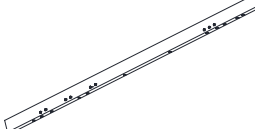
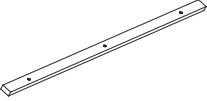
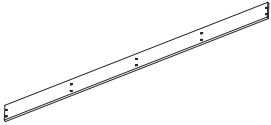
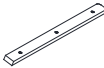

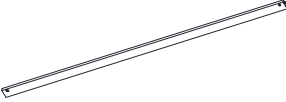
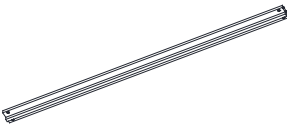

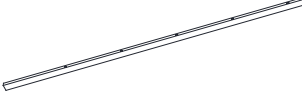
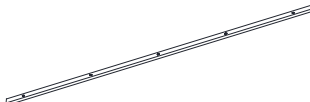
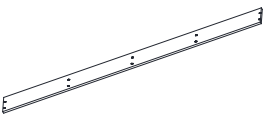
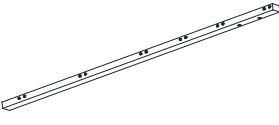
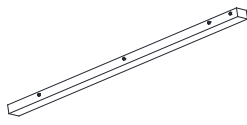



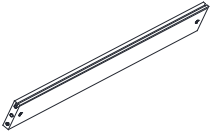
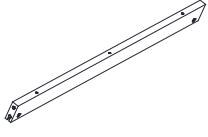
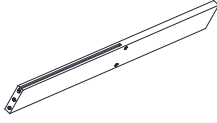
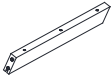
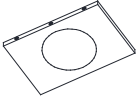

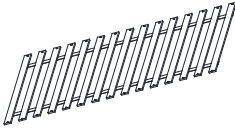

Stückliste 2/2



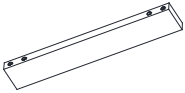

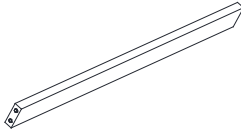
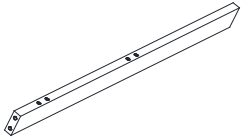
WF315421WAA

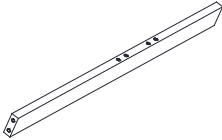
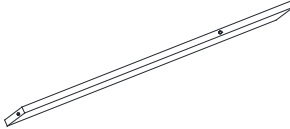
1 x1 	2 x1 	3 x1 	4 x1 
6 x3 	10 x1 	14 x1 	15 x1 
16 x3 	17 x3 	18 x1 	19 x1 
20 x1 	24 x1 	38 x1 	39 x1 

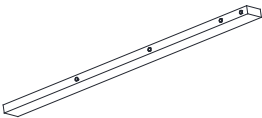
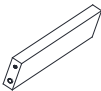
WF31542WAA

7 x1 	9 x1 	11 x1 	13 x1 
21 x1 	22 x10 	23 x2 	25 x3 
26 x2 	27 x1 	28 x3 	29 x2 
36 x2 	37 x2 	40 x1 	41 x1 
42 x2 	44 x1 	45 x1 	46 x1 
47 x1 	48 x3 		

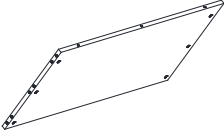
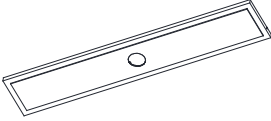

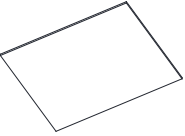
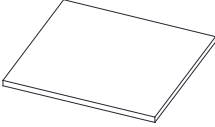
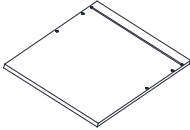
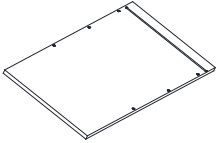
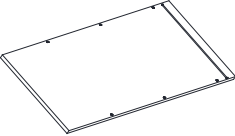
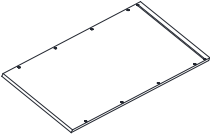



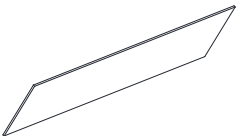
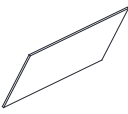
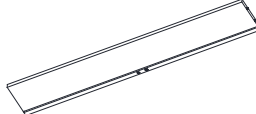
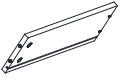
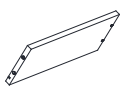
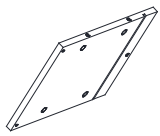
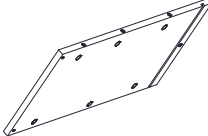
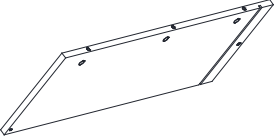
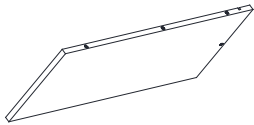
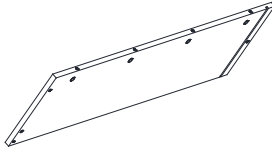
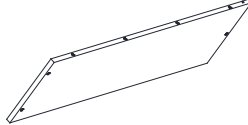
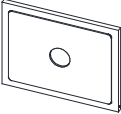

















WF315423WAA

<p>5 x2</p> 	<p>30 x2</p> 	<p>34 x2</p> 	<p>35 x2</p> 
<p>43 x4</p> 	<p>49 x1</p> 	<p>50 x1</p> 	<p>51 x1</p> 
<p>52 x1</p> 	<p>53 x1</p> 		

WF315424WAA



<p>8 x1</p> 	<p>12 x1</p> 	<p>31 x2</p> 	<p>32 x2</p> 
<p>33 x2</p> 	<p>54 x2</p> 	<p>55 x2</p> 	<p>56 x1</p> 
<p>57 x1</p> 	<p>58 x1</p> 	<p>59 x1</p> 	<p>60 x4</p> 

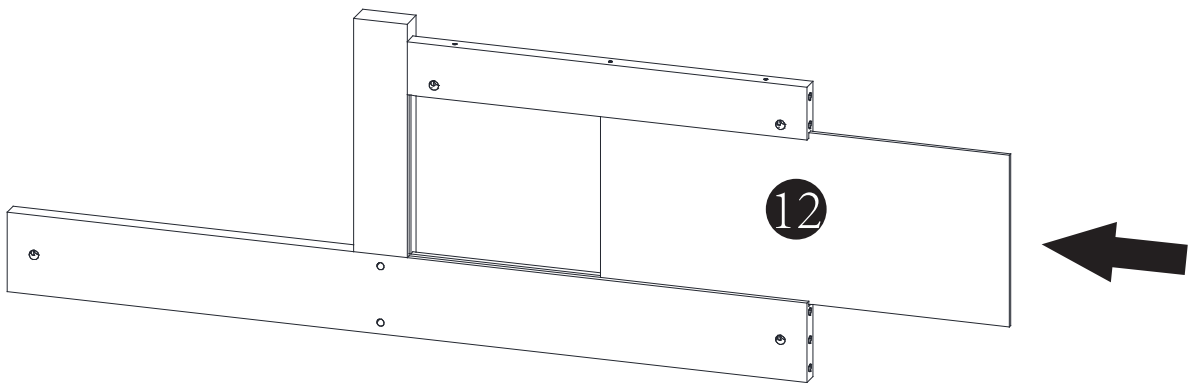
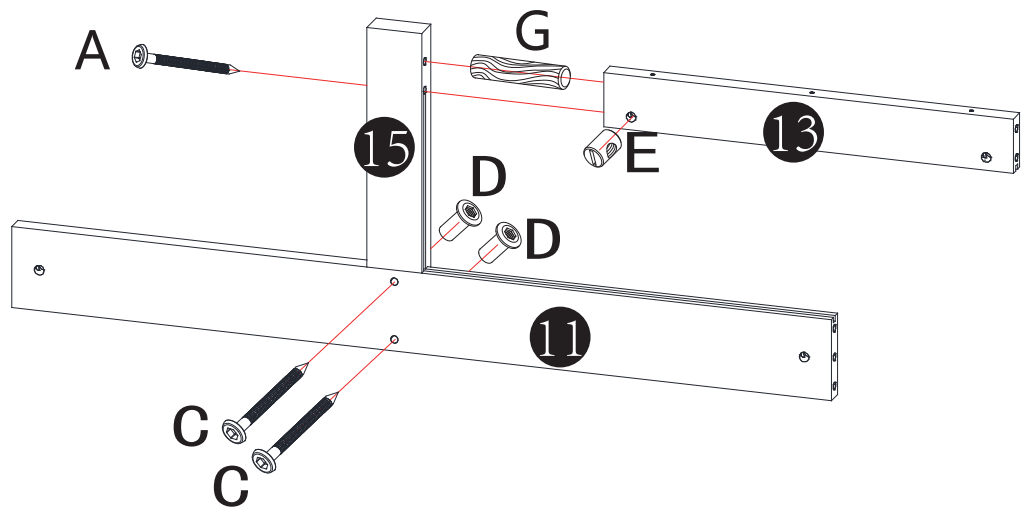
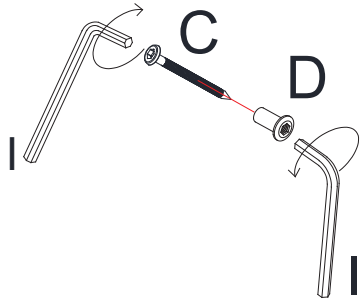

Hardware-Liste + WF 315422WAA

A		M6*100mm	25
B		M6*70mm	19
C		M6*20mm	2
D		M6*20mm	6
E			50
F		Φ4*30mm	105
G		Φ8*30mm	115
H		Φ6*90mm	11
I		M4	2
J			1
K			8
L		Φ5*35mm	34
M		M6*90mm	6
N		Φ3.5*14mm	28
O			4
P			50
Q			50
R			2
S		M6*110mm	2
T		M3	1
U		Φ6*70mm	3
V			8
W		M6*80mm	2
X		Φ7*30mm	12

Schritt 1





C		M6*20mm	2
E			1
G		Φ8*30mm	1

D		M6*20mm	2
I		M4	2
A		M6*100mm	1

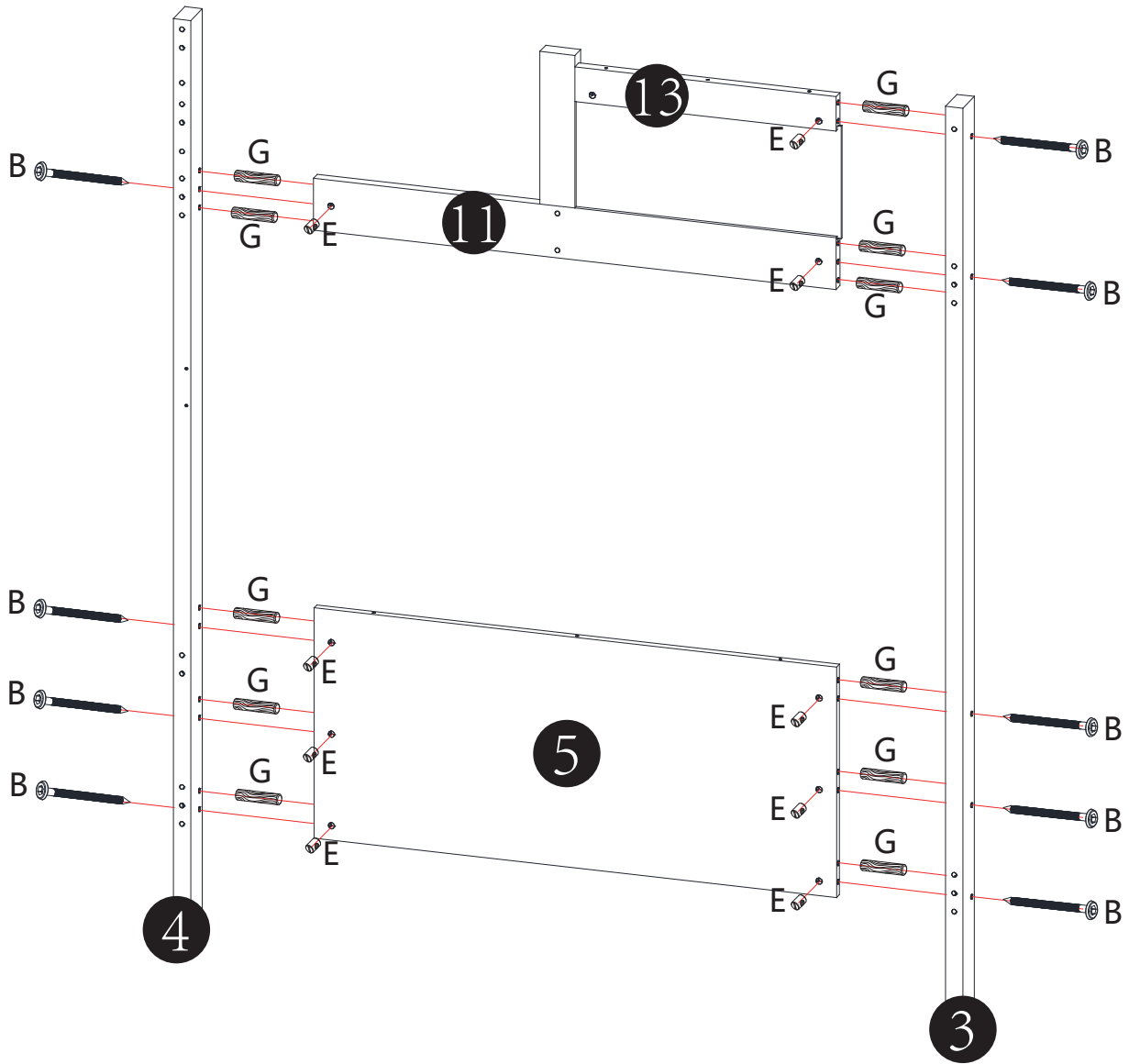
Schritt 2



E			9
G		Φ8*30mm	11

I		M4	1
B		M6*70mm	9

Schritt 3

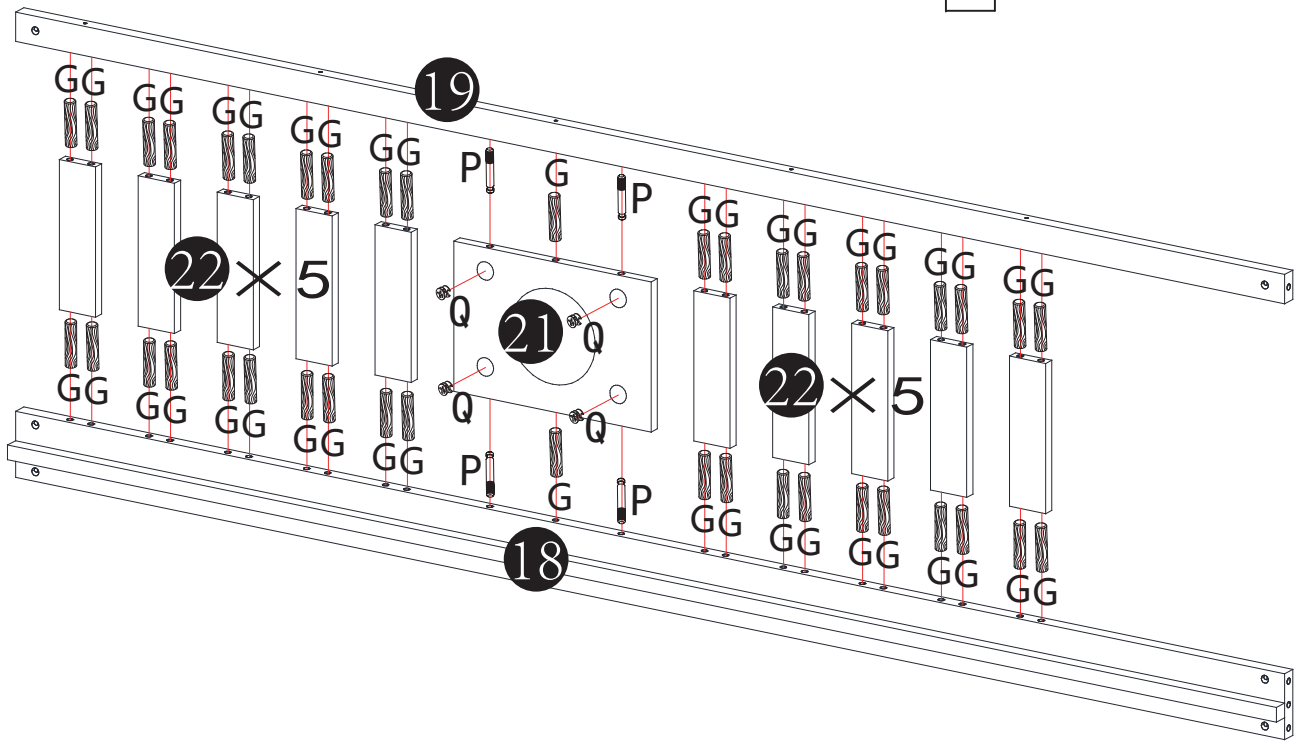
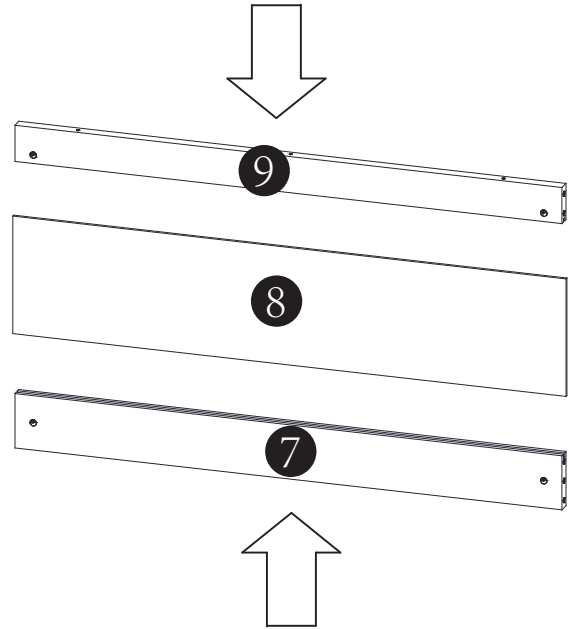
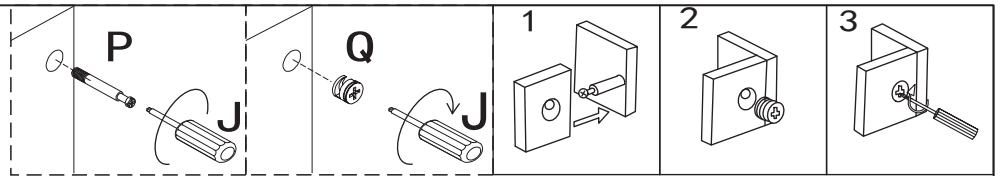



G		Φ8*30mm	42
J			1

P			4
Q			4

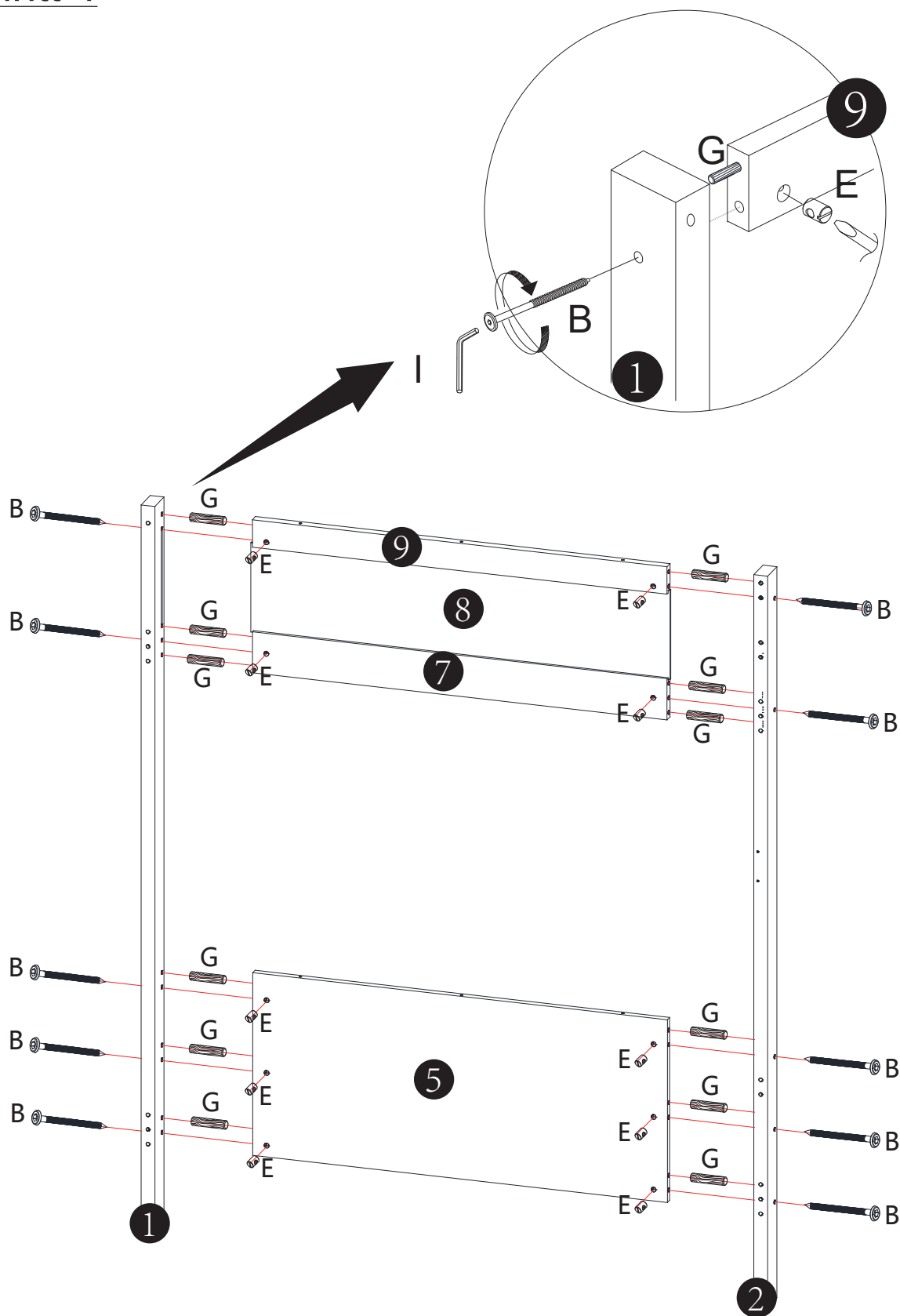
Schritt 4





E			10
G		Φ8*30mm	12

I		M4	1
B		M6*70mm	10

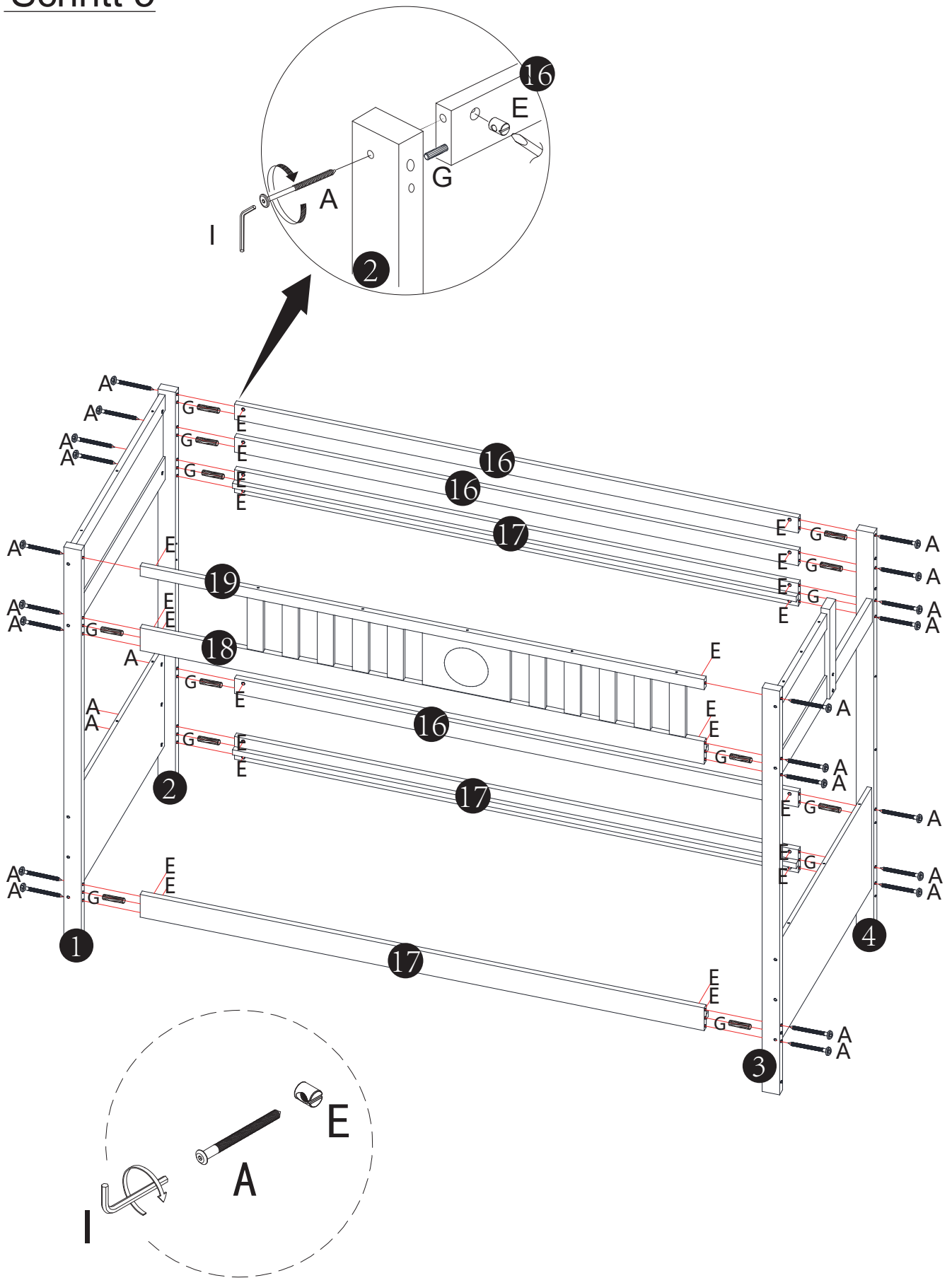
Schritt 5





E		24
G	 $\varnothing 8 \times 30 \text{mm}$	14

I		M4	1
A		M6*100mm	24

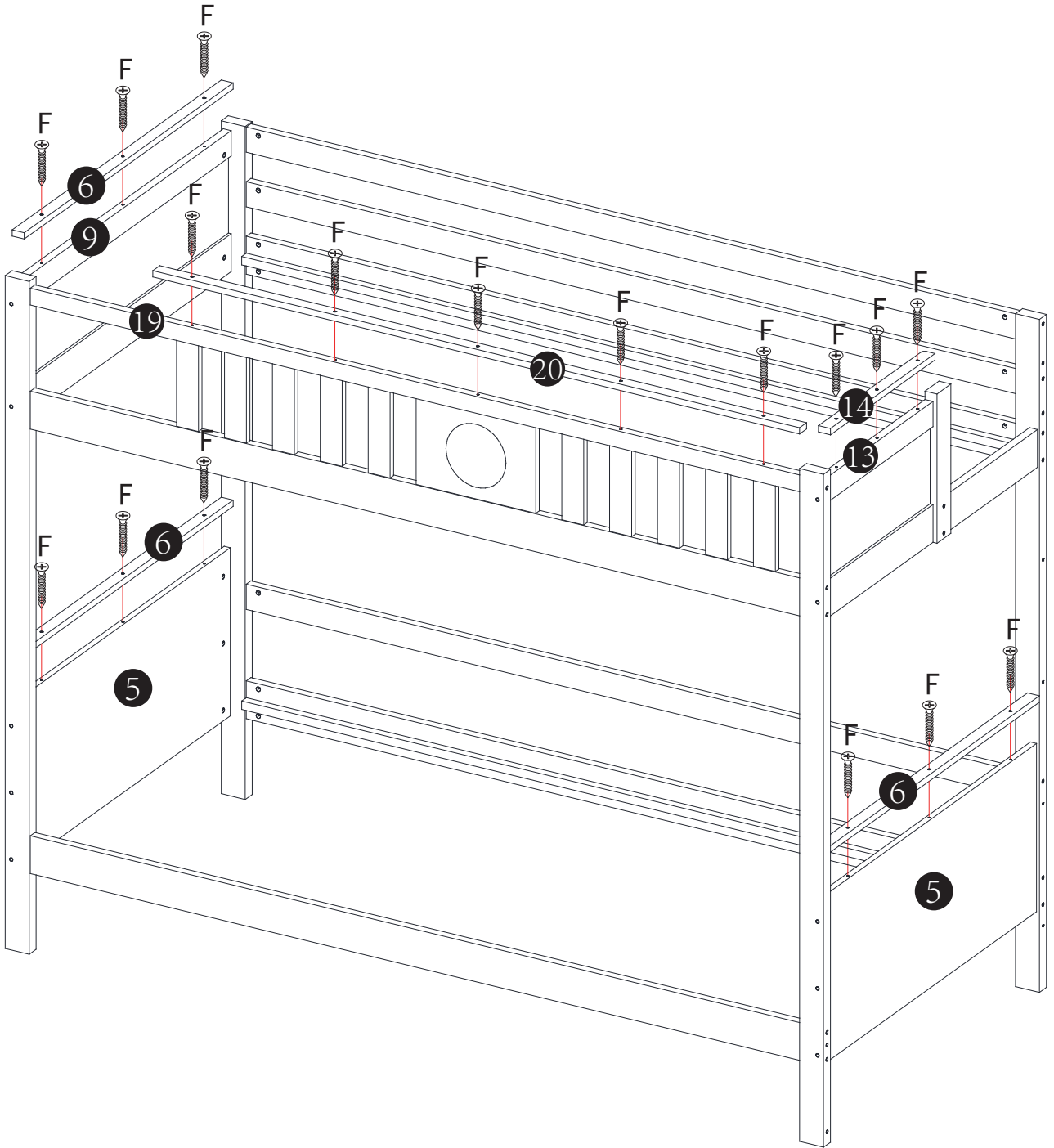

Schritt 6

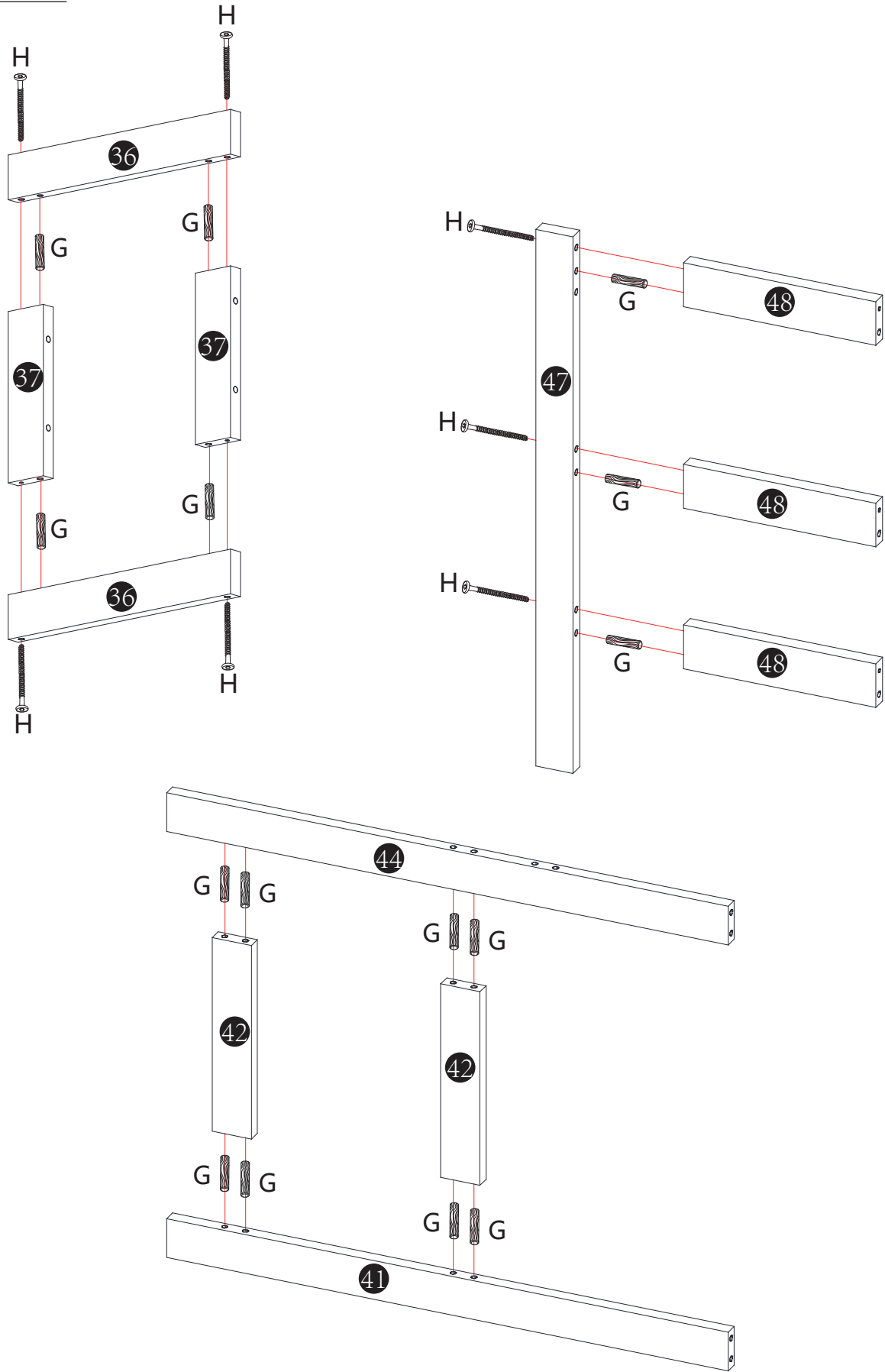

F		Φ4*30mm	17
J			1

Schritt 7





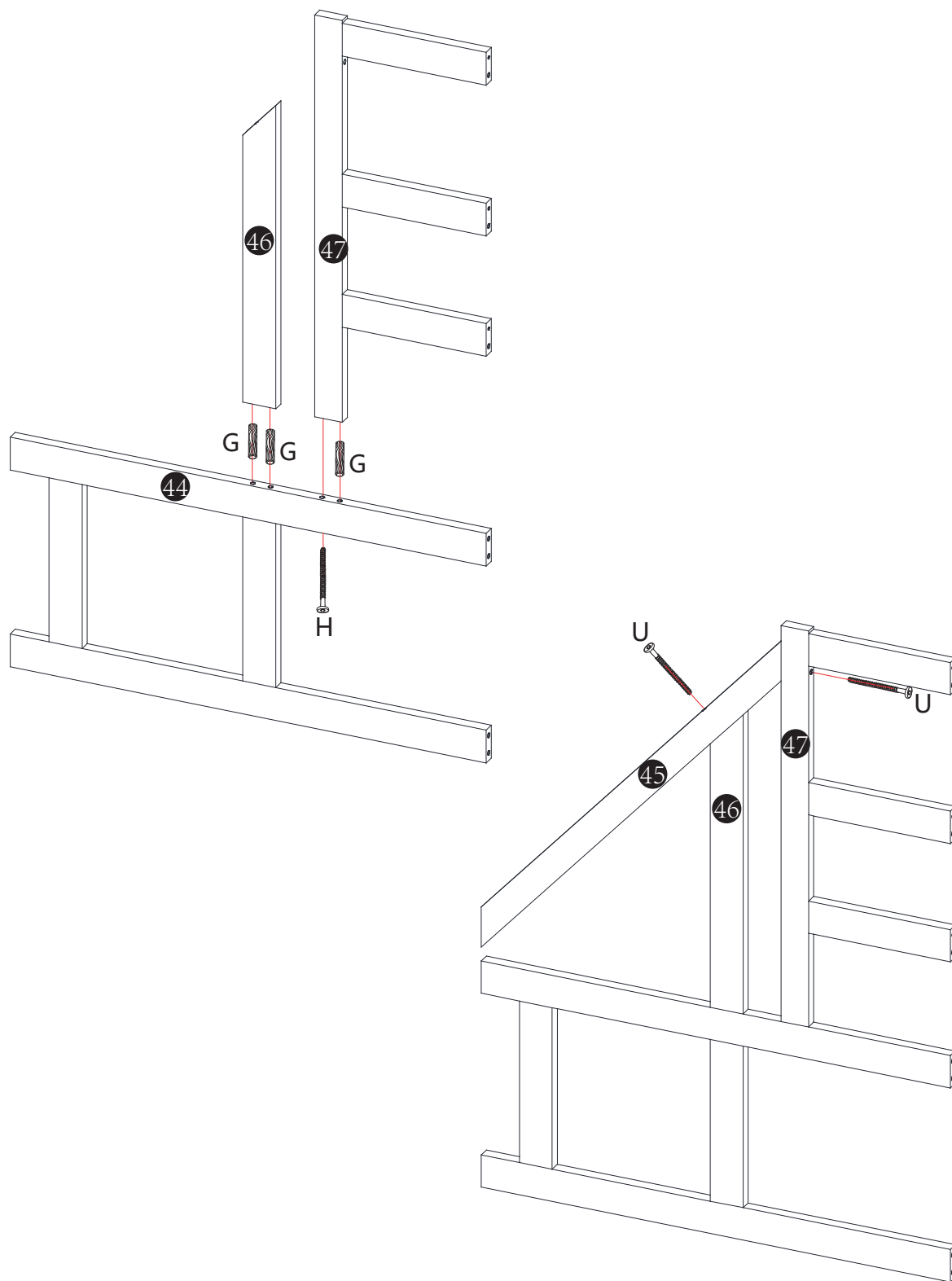

G		Φ8*30mm	15
H		Φ6*90mm	7

I		M4	1
---	---	----	---

Schritt 8







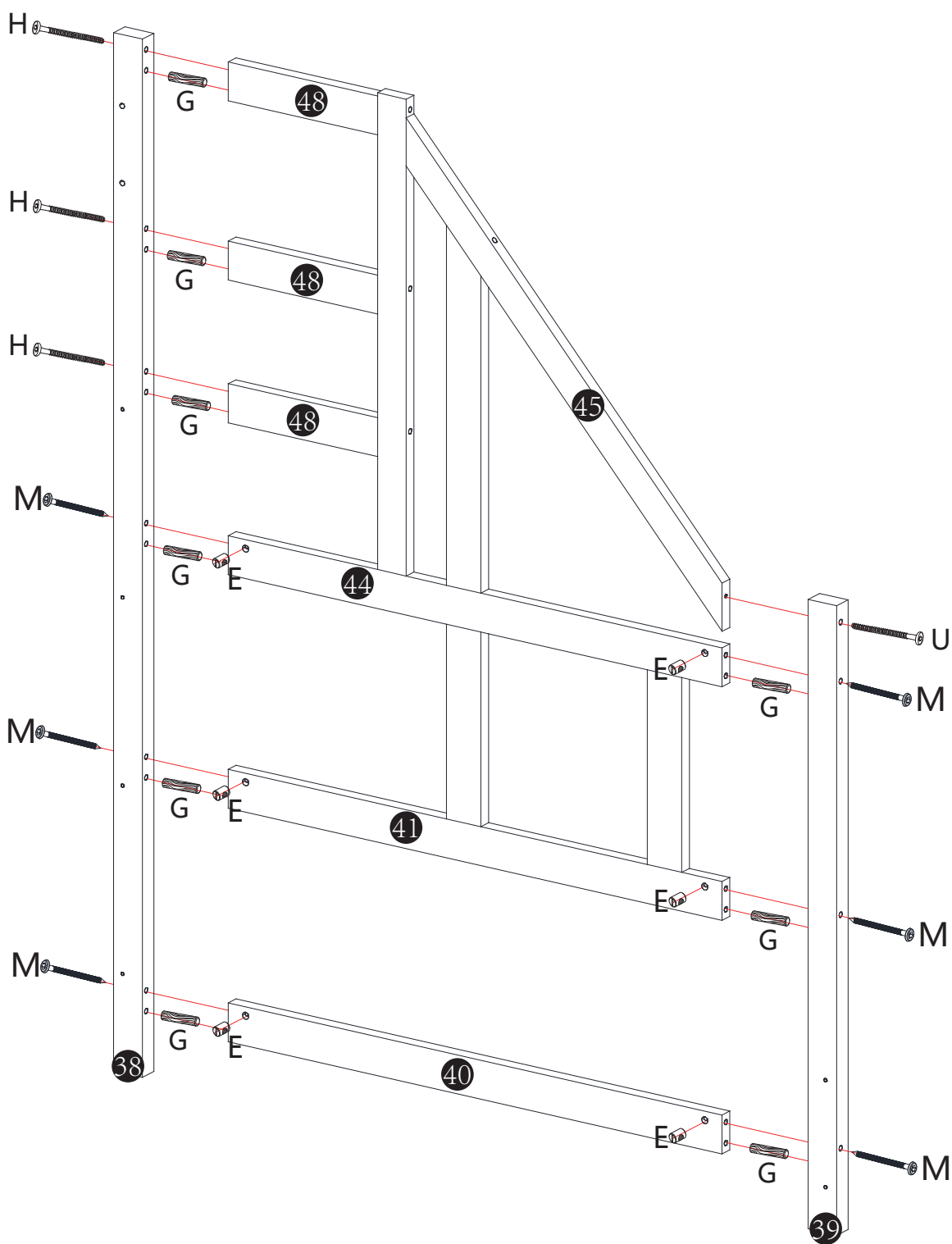

G		Φ8*30mm	3
H		Φ6*90mm	1

U		Φ6*70mm	2
I		M4	1

Schritt 9





E			6
G		Φ8*30mm	9
H		Φ6*90mm	3

I		M4	1
M		M6*90mm	6
U		Φ6*70mm	1

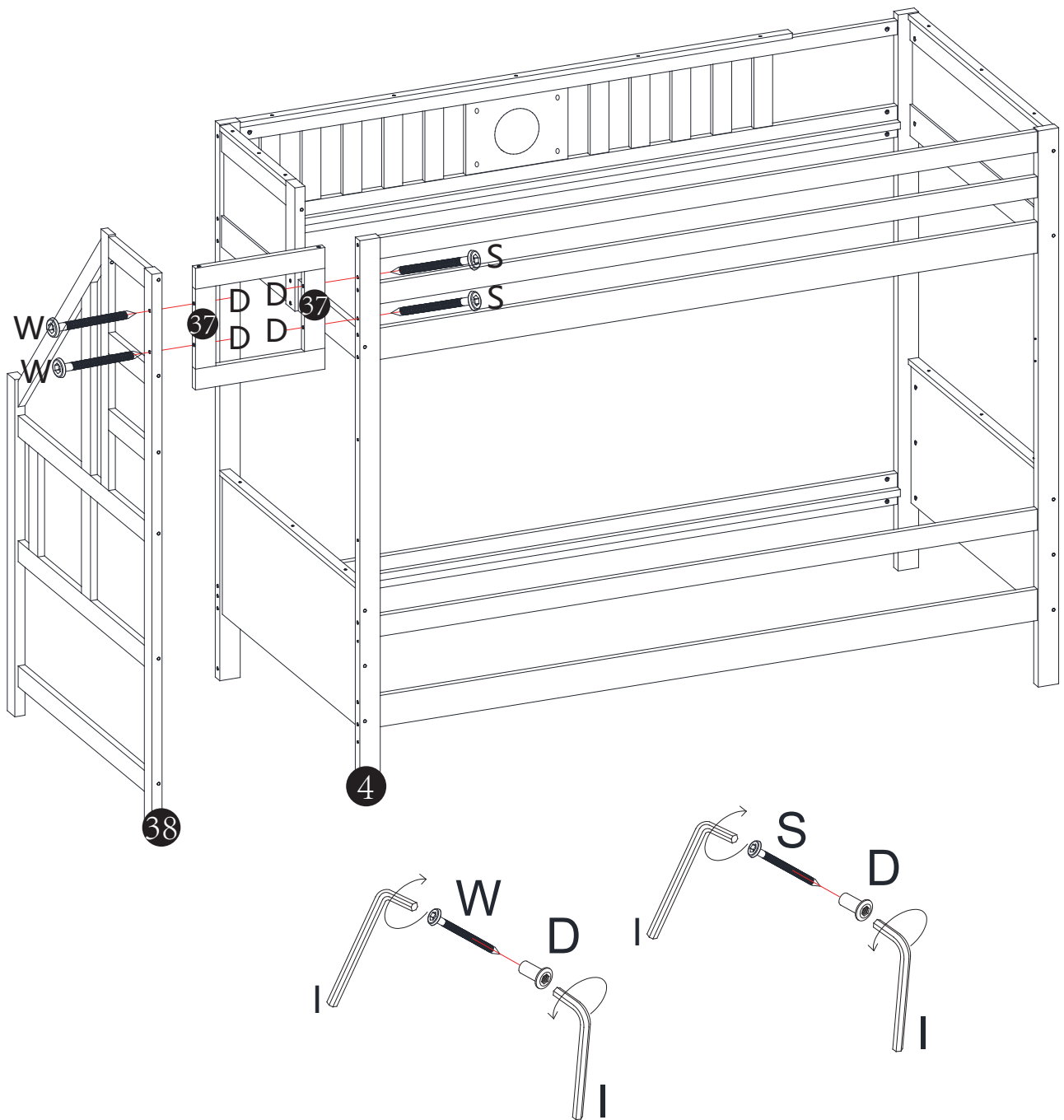
Schritt 10





D		M6*20mm	4
I		M4	2

S		M6*110mm	2
W		M6*80mm	2

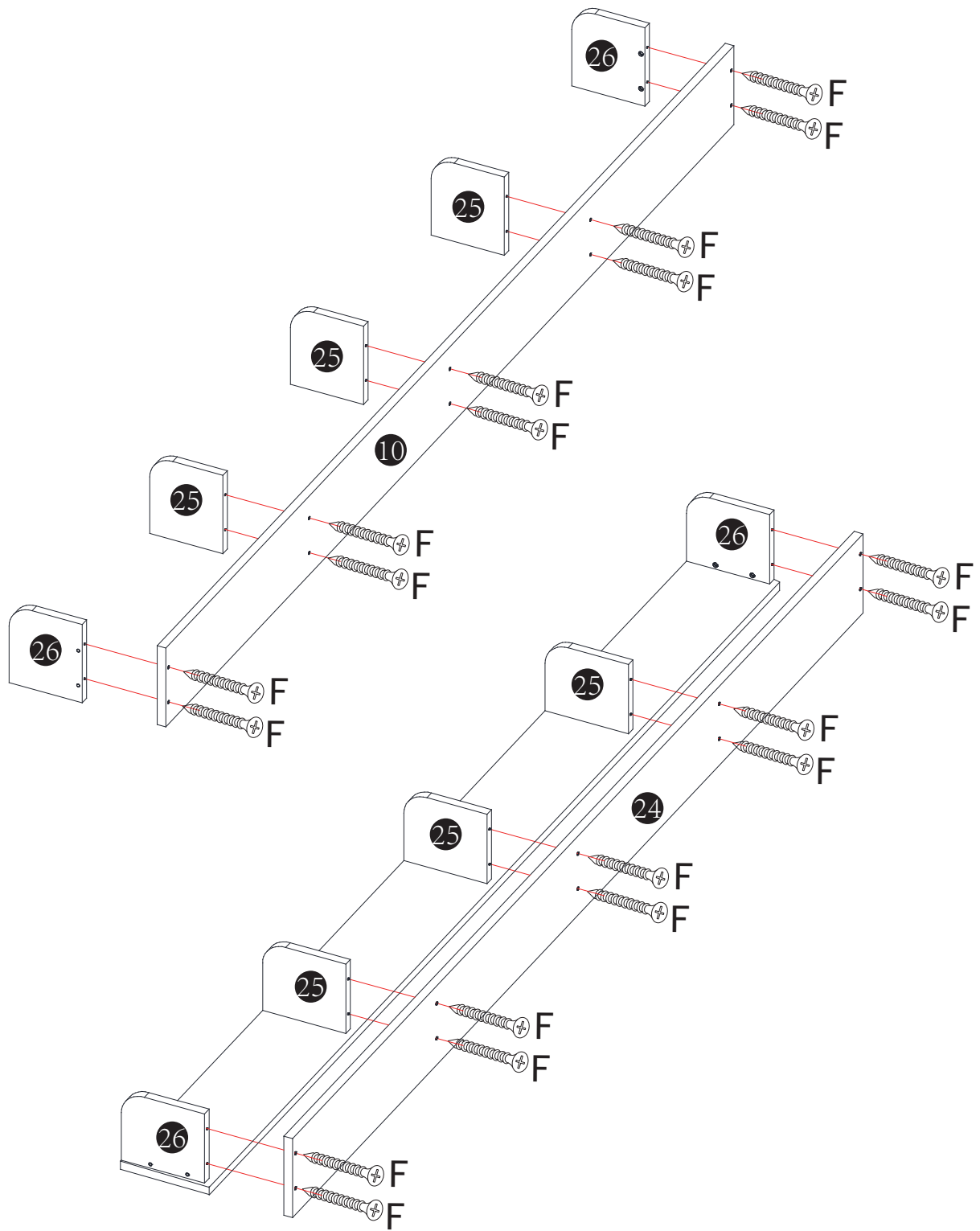

Schritt 11



F		Φ4*30mm	20
J			1

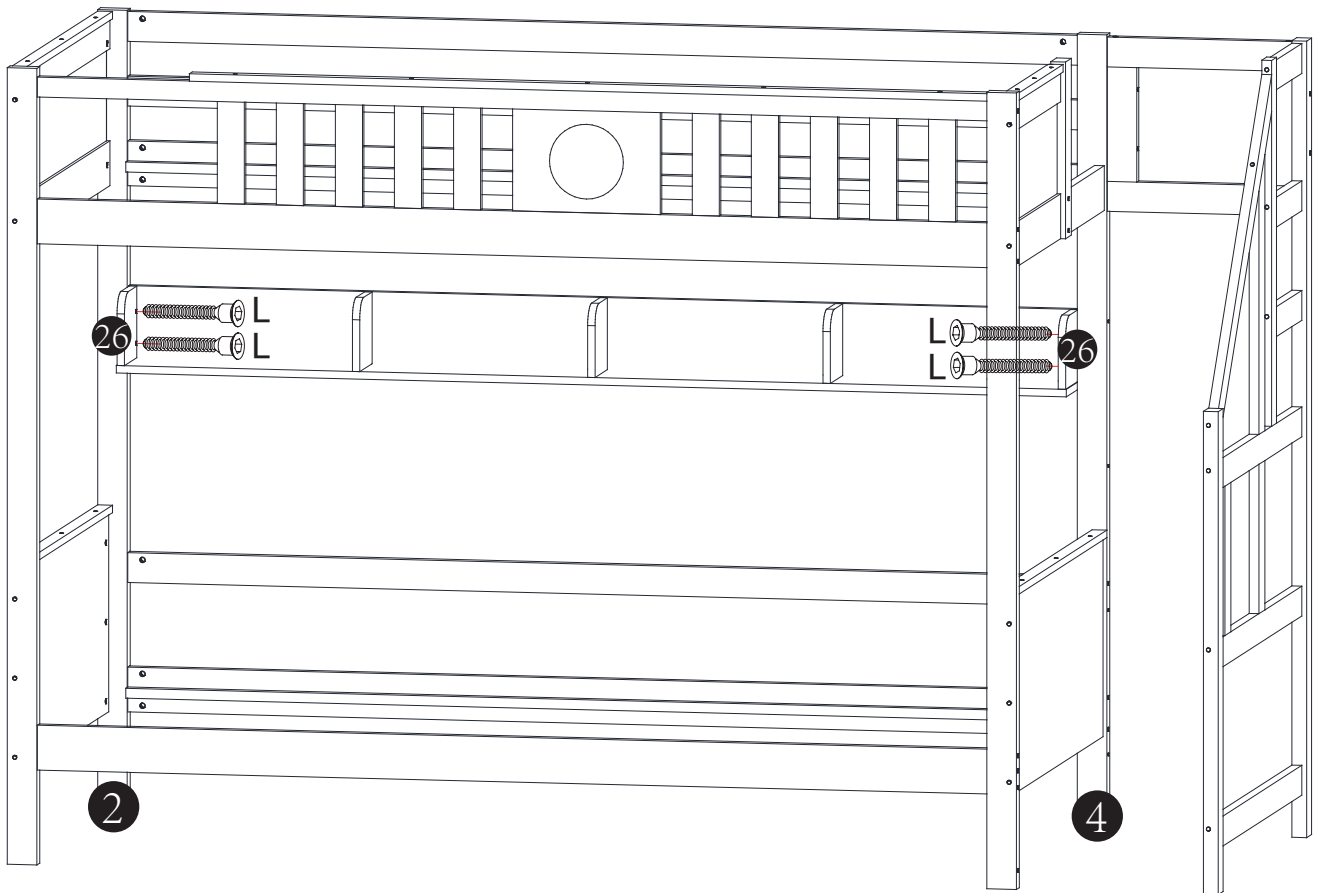

Schritt 12

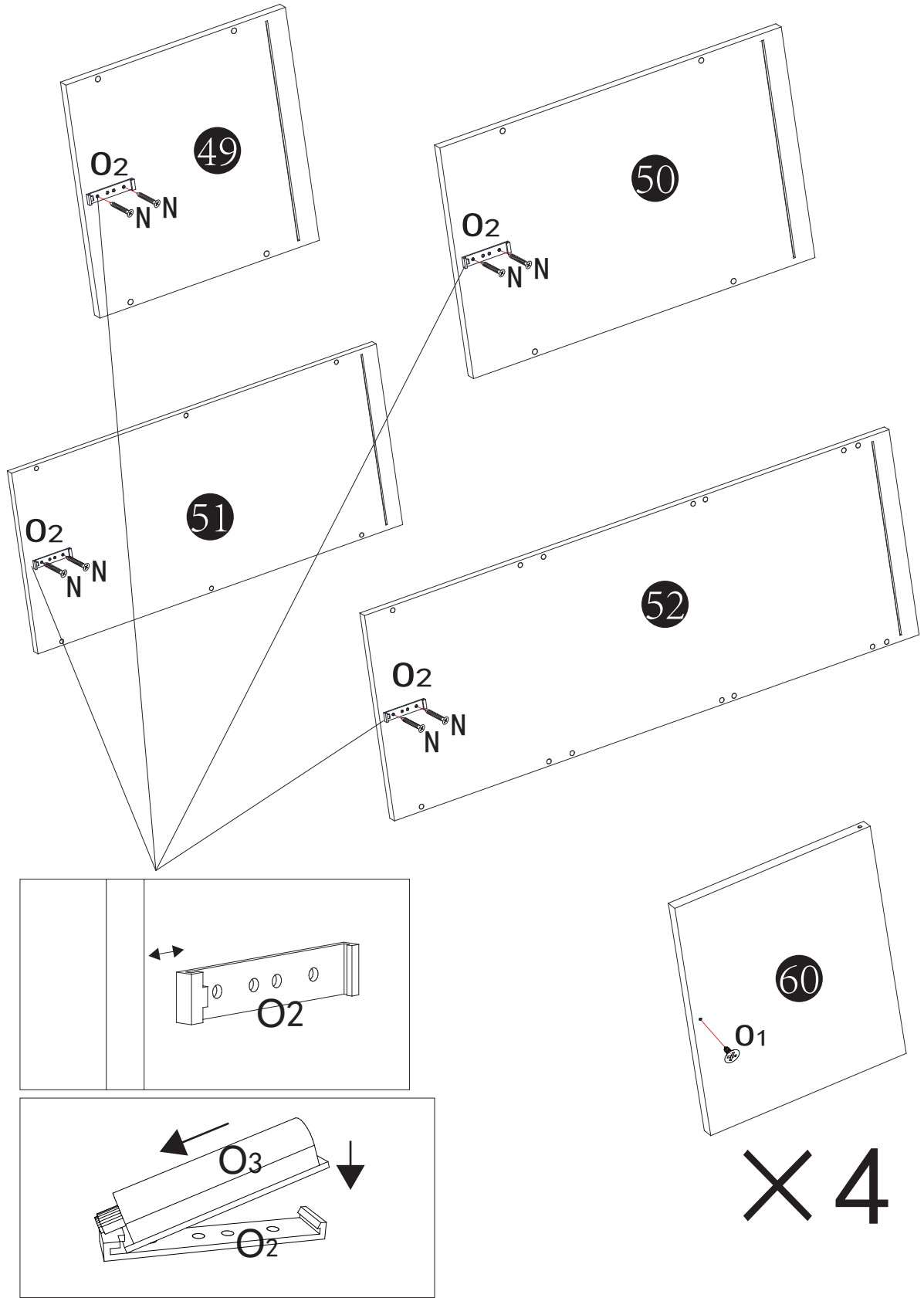

L		Φ5*35mm	4
T		M3	1

Schritt 13





N		Φ3.5*14mm	8
O			4

J		1
---	---	---

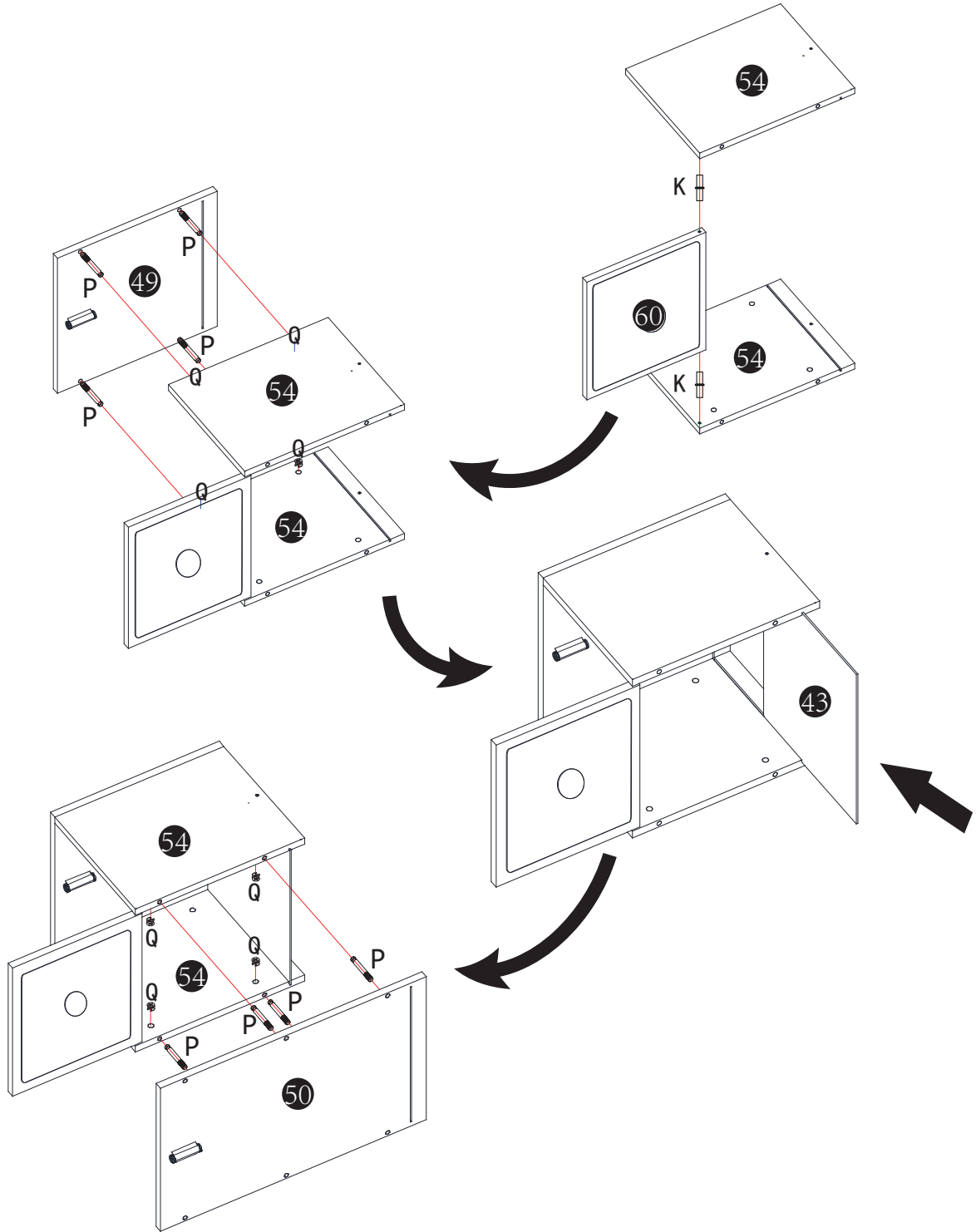
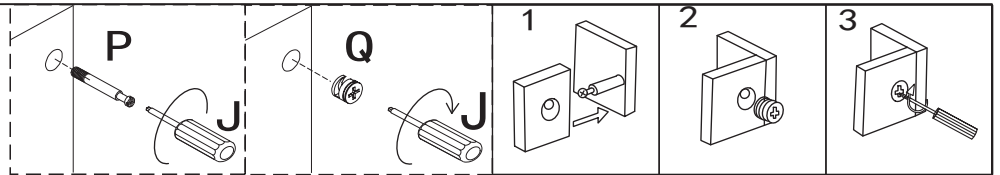
Schritt 14



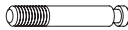

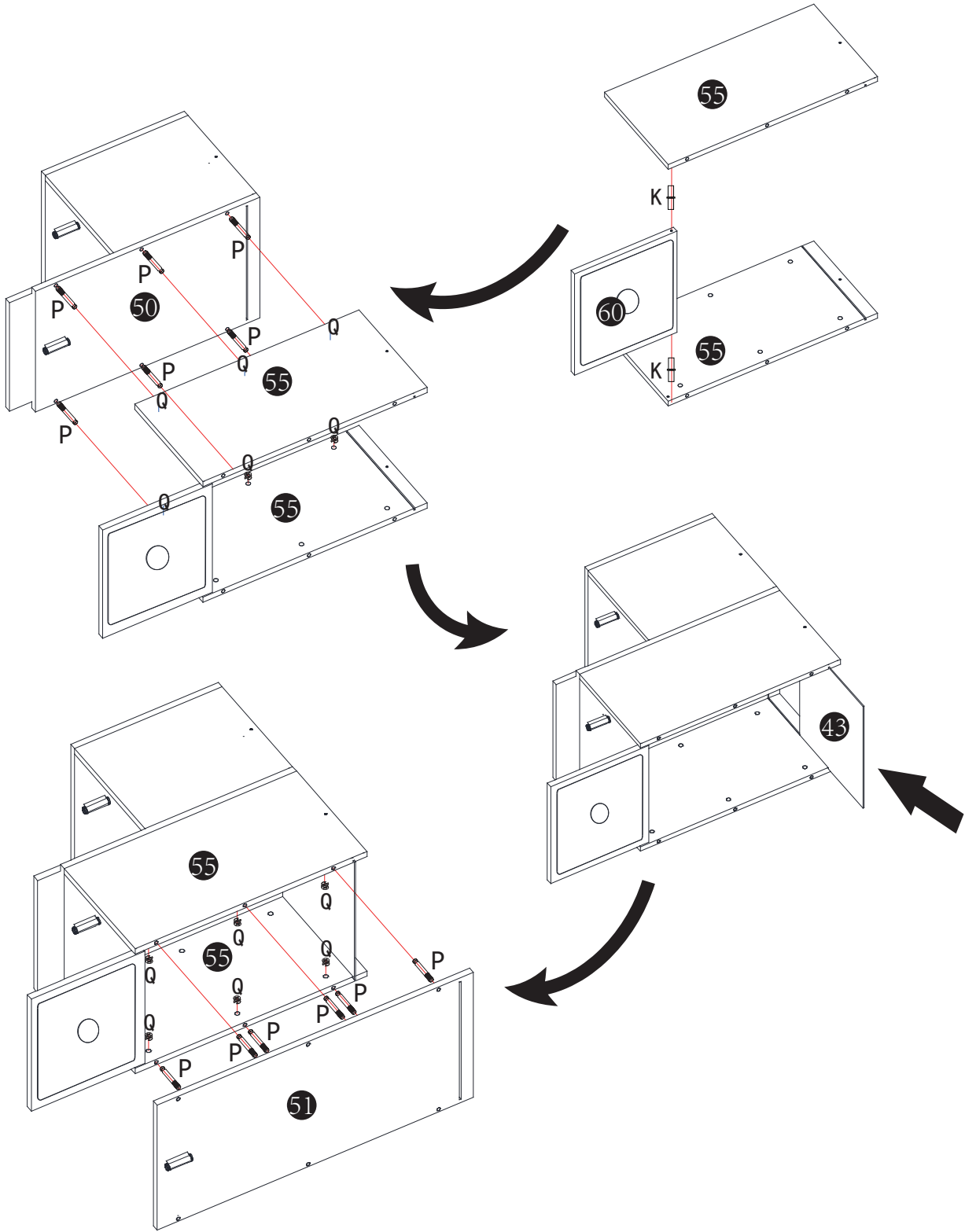
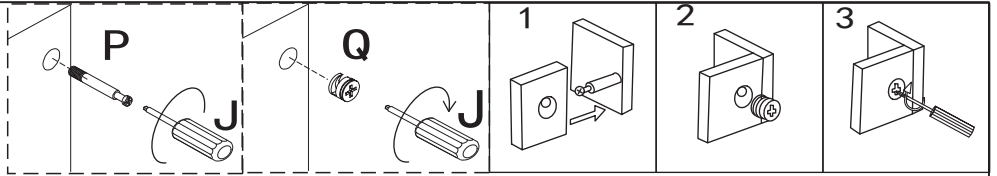

K		2
J		1

P		8
Q		8

Schritt 15



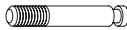



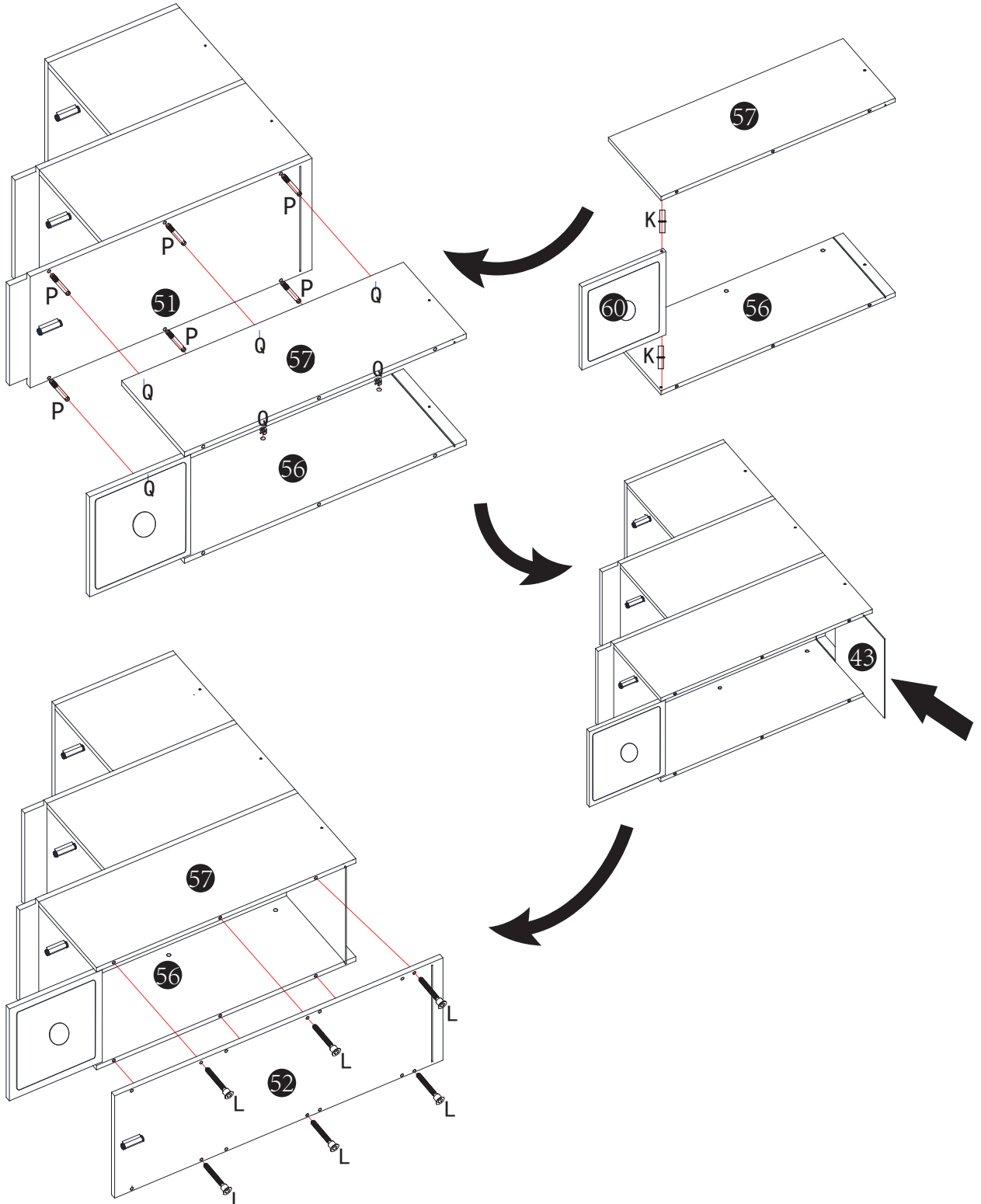
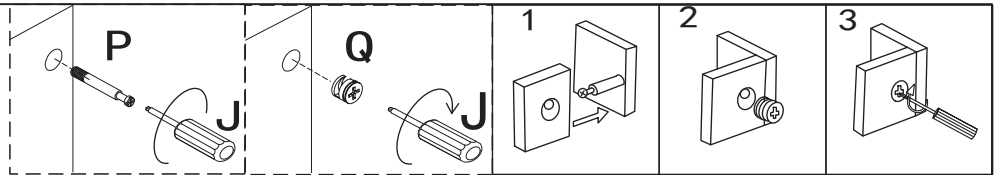

K		2
J		1

P		12
Q		12

Schritt 16

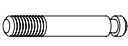

K			2
L		Φ5*35mm	6
T		M3	1

J			1
P			6
Q			6

Schritt 17

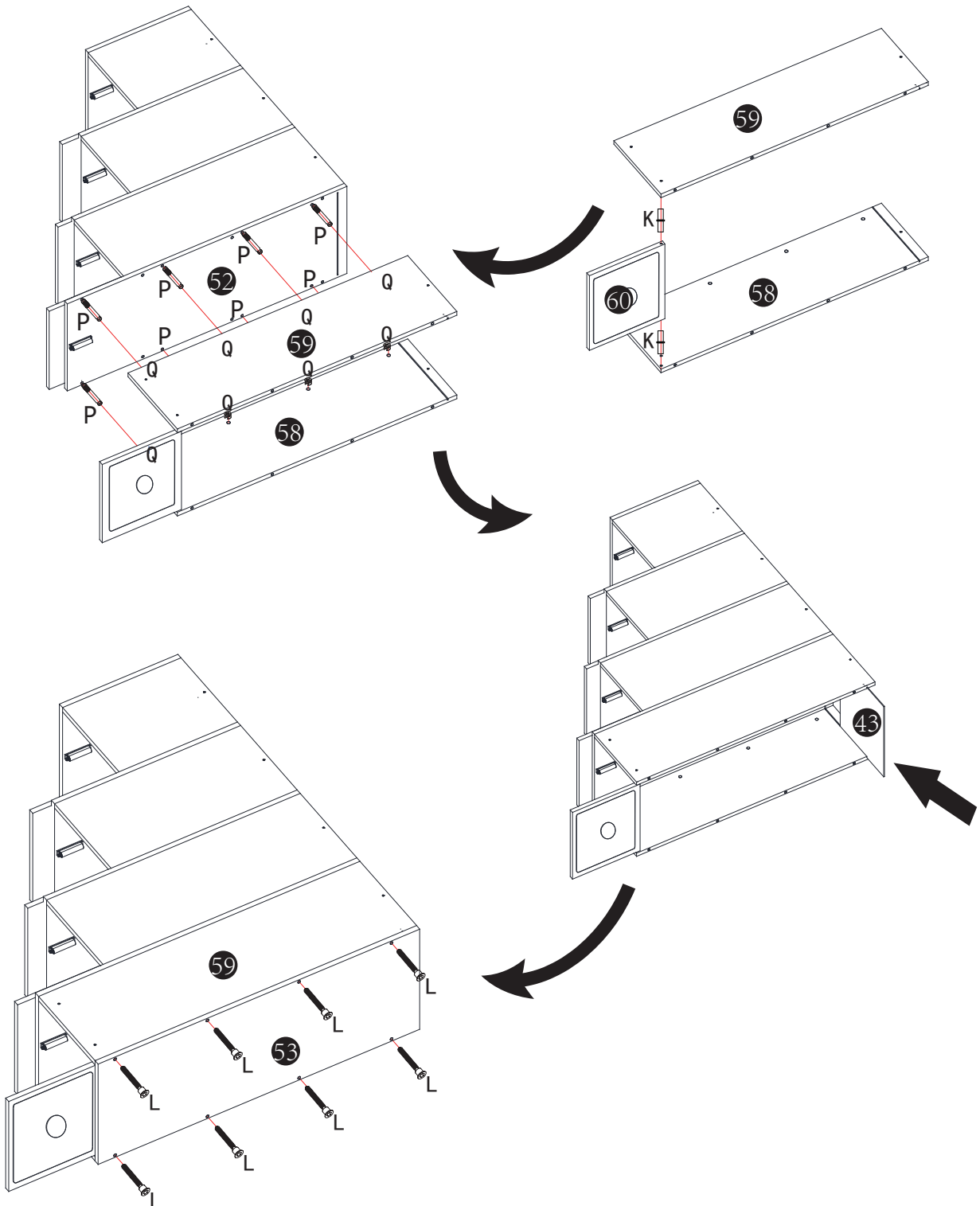
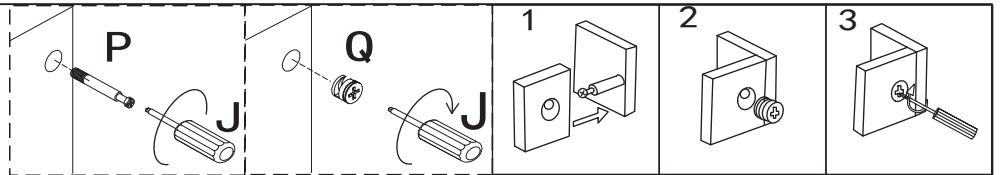

K			2
L		Φ5*35mm	8
T		M3	1

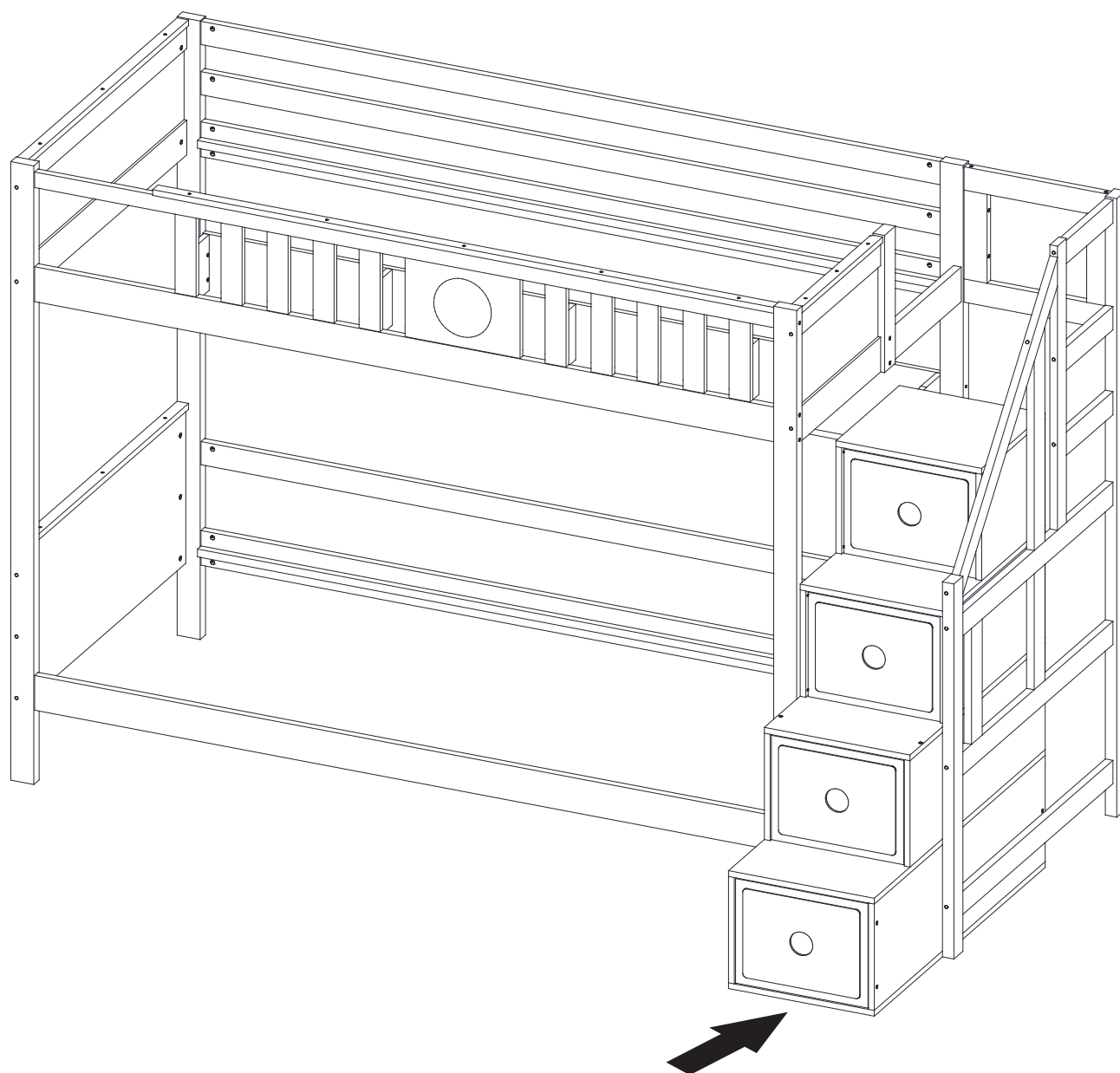
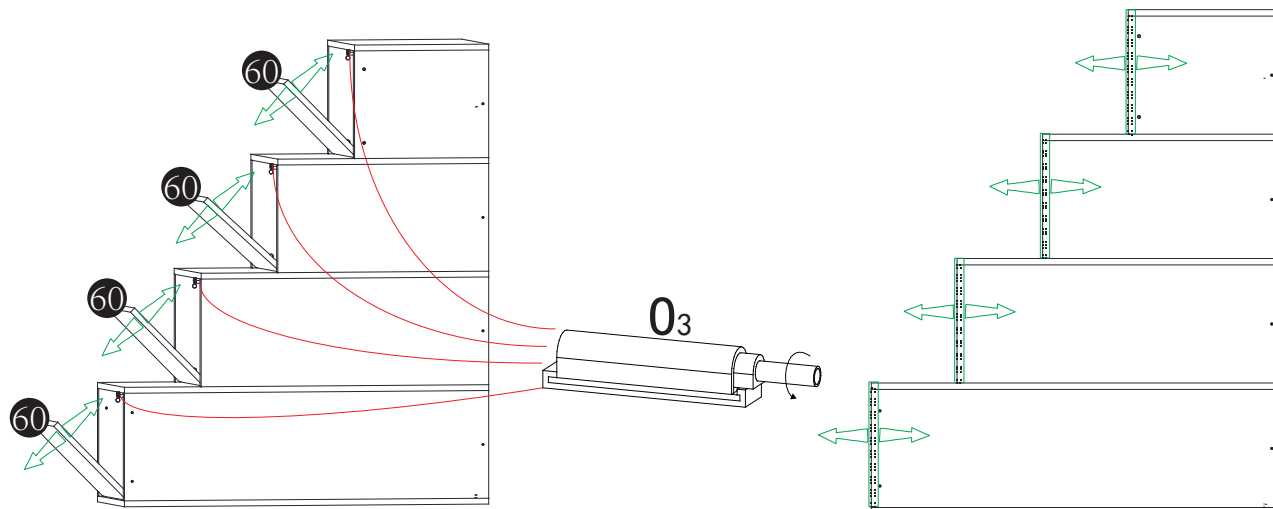

J			1
P			8
Q			8

Schritt 18



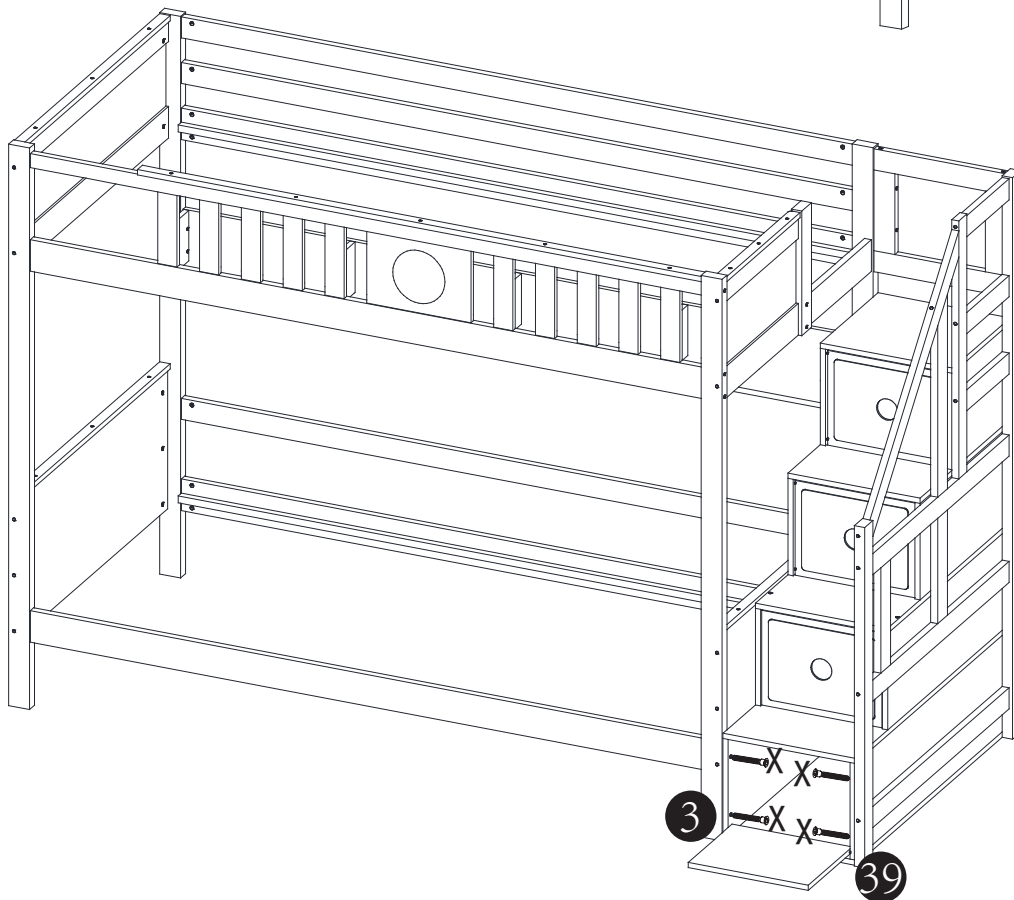
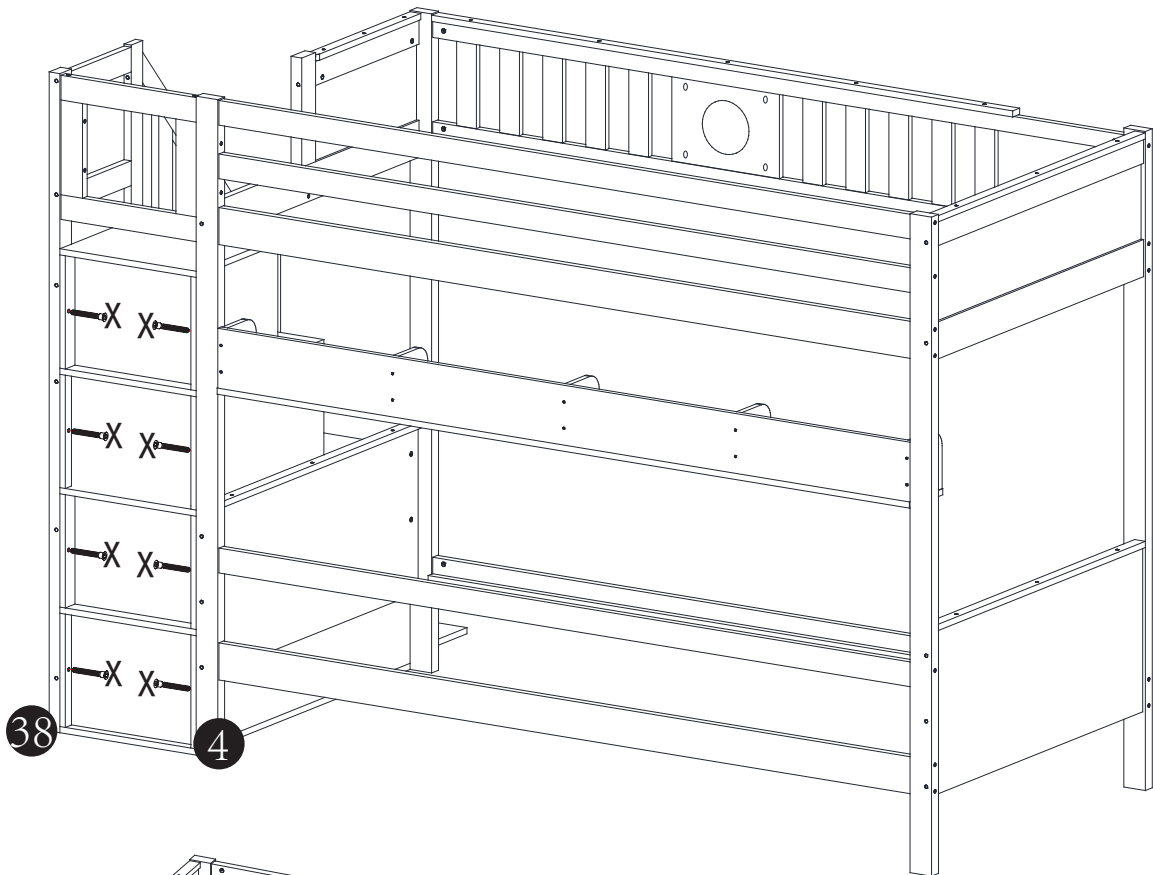

Schritt 19



I		M4	1
X		Φ7*30mm	12

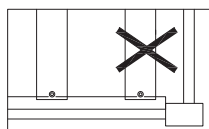
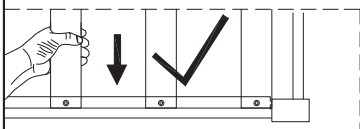
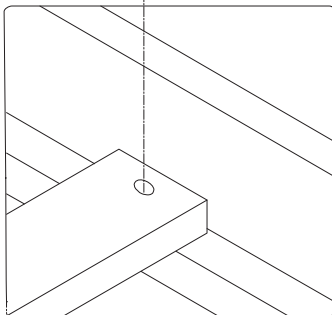
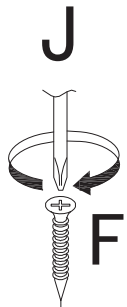
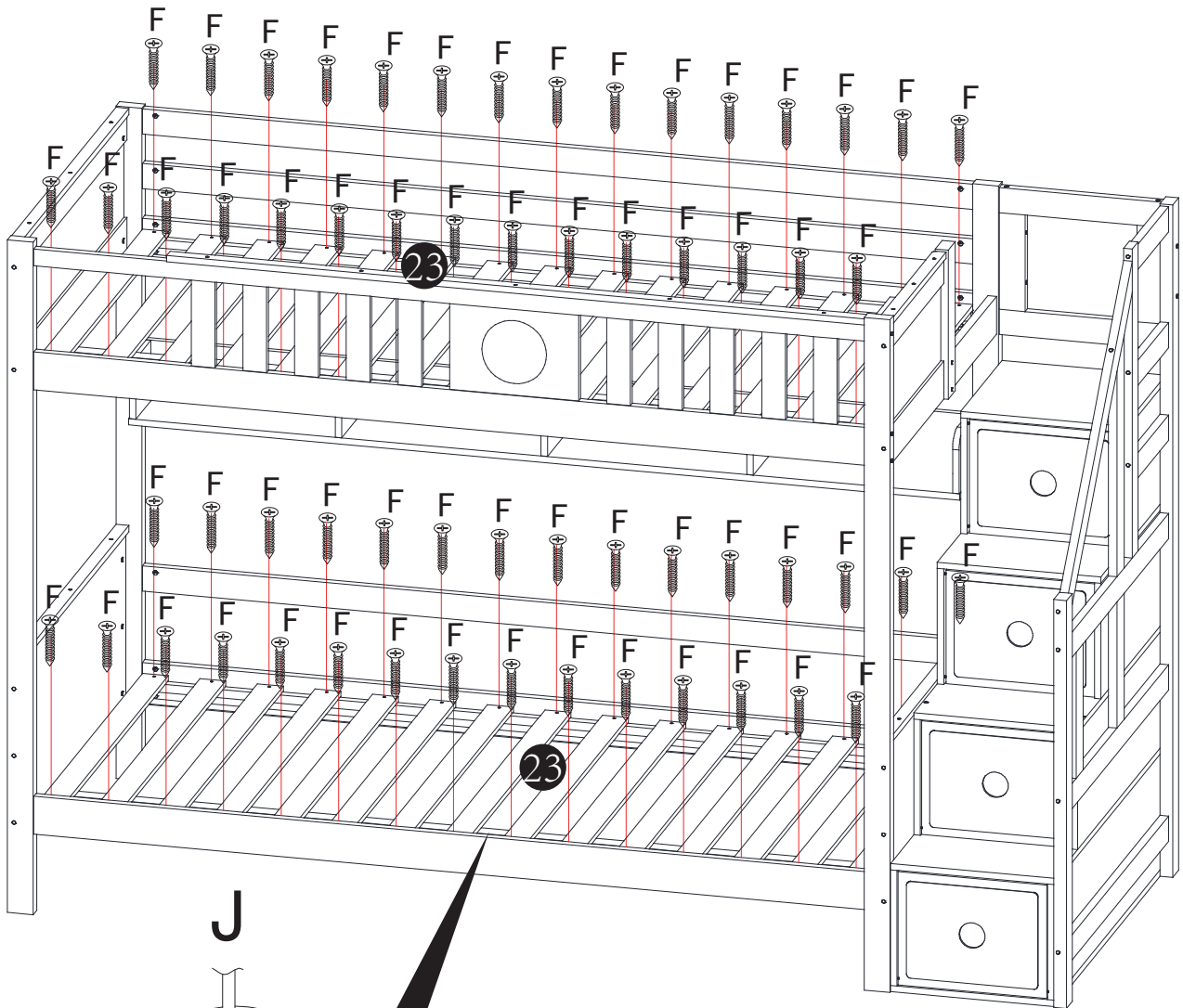

Schritt 20



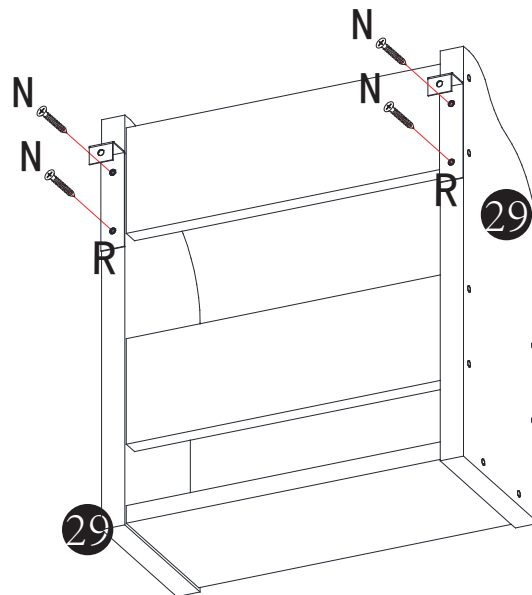
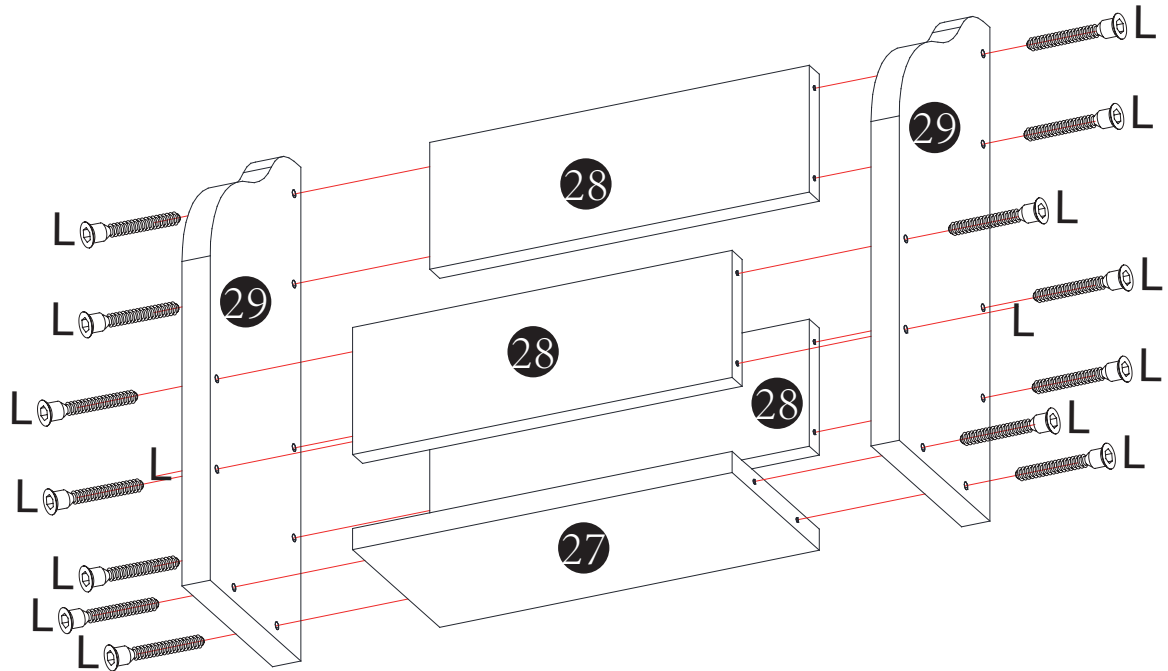

F		Φ4*30mm	60
J			1

Schritt 21



R		2
N	 $\Phi 3.5 \times 14 \text{mm}$	4
J		1

L	 $\Phi 5 \times 35 \text{mm}$	16
T	 M3	1

Schritt 22

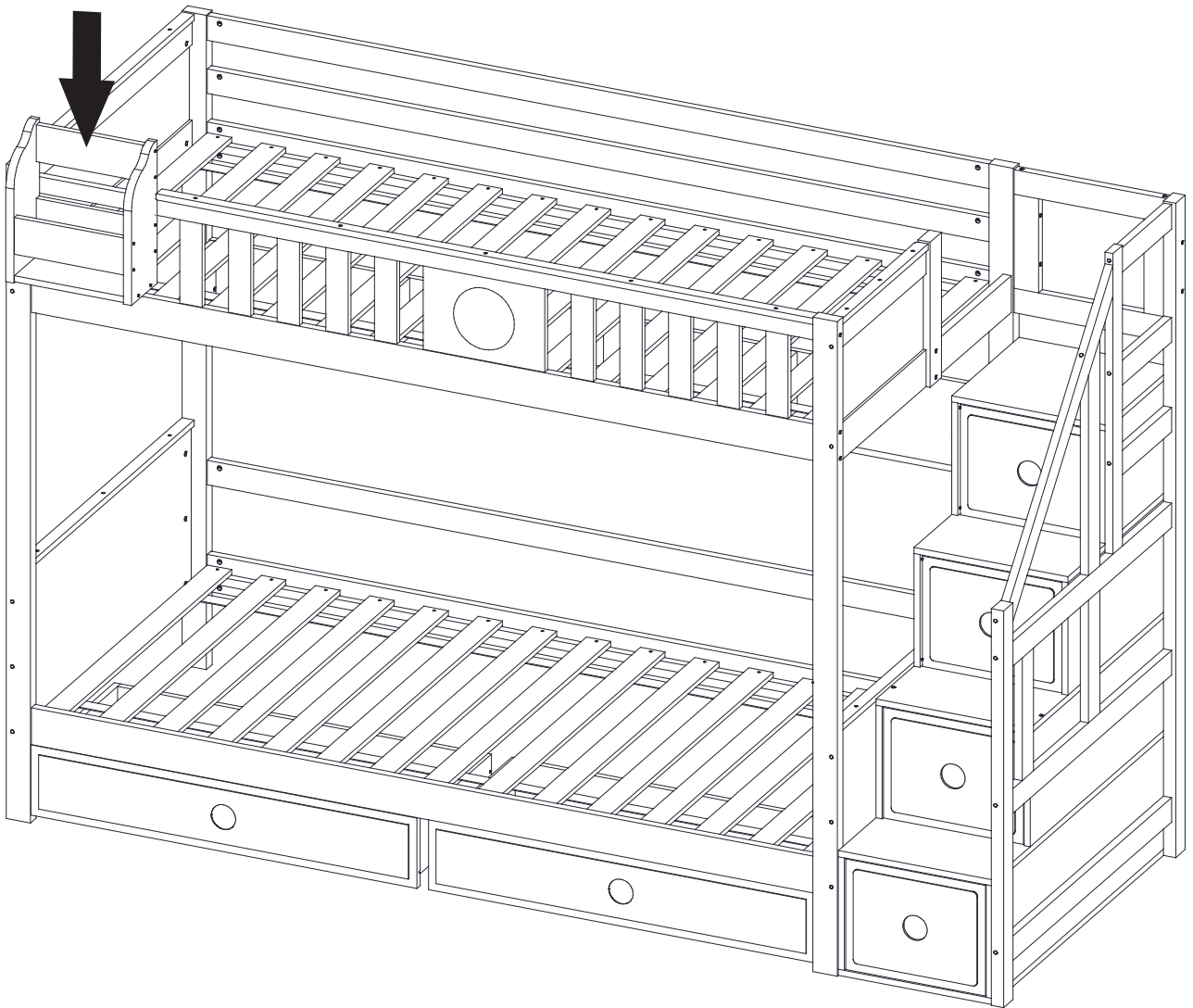

Schritt 23

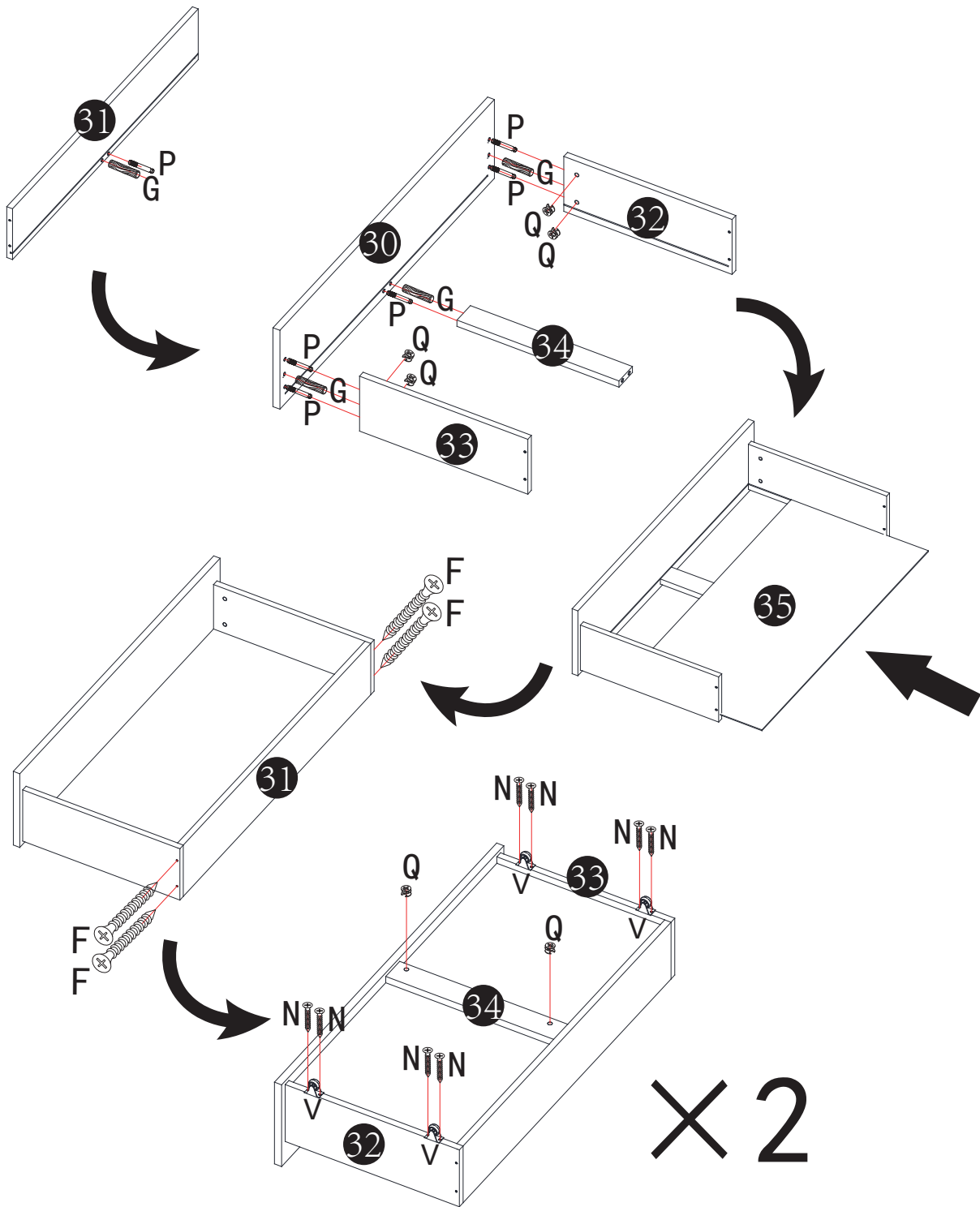
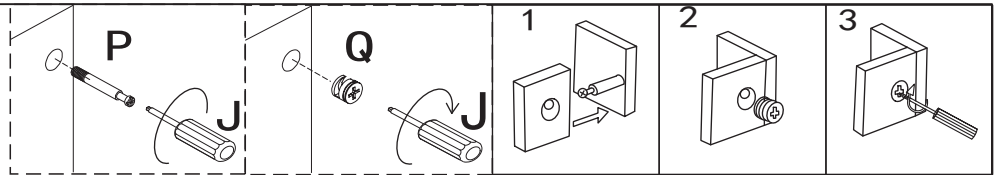

N		Φ3.5*14mm	16
P			12
Q			12
V			8

G		Φ8*30mm	8
F		Φ4*30mm	8
J			1

Schritt 24

