

# 48829

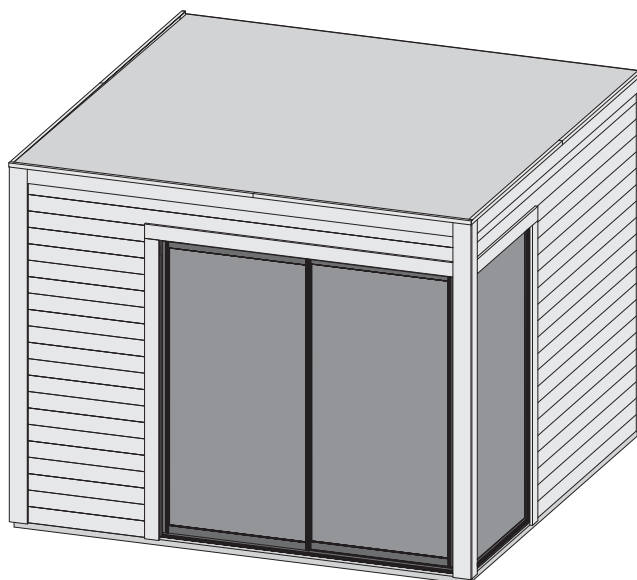

-  **Aufbauanleitung**
-  **Building Instructions**
-  **notice de montage**
-  **montagehandleiding**
-  **Montagevejledning**
-  **Instrucciones de construcción**
-  **Istruzioni per il montaggio**
-  **Montážní návod**



[info@karibu.de](mailto:info@karibu.de)

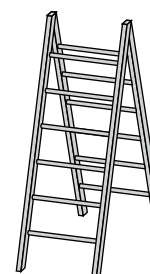
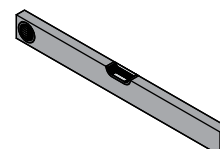
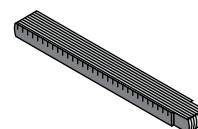
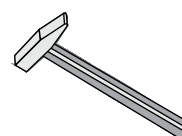
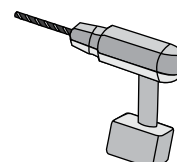
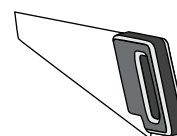

## Technische Daten

In der Auftragsbestätigung bzw. Lieferschein ist der gekaufte Ofentyp bzw. das erworbene Steuergerät zu finden. Bitte entnehmen Sie die technischen Daten Ihrer Geräte der folgenden Auflistung

	<b>Netzspannung</b>	<b>Wattage</b>
<b>Ofen</b>		
9kW Bio	400V ~ 3N	9kW
9kW Finnisch	400V ~ 3N	9kW
9kW integr. Steuerung	400V ~ 3N	9kW
4,5kW Bio	400V ~ 3N	4,5kW
4,5kW Finnisch	400V ~ 3N	4,5kW
4,5kW integr. Steuerung	400V ~ 3N	4,5kW
3,6kW Bio	230V ~ 1N	3,6kW
3,6kW Finnisch	230V ~ 1N	3,6kW
3,6kW integr. Steuerung	230V ~ 1N	3,6kW
<b>Steuergerät</b>		
externe Easy Bio	400V ~ 3N	max. 10,8kW
externe Plug&Play Bio	240V ~ 3N	max. 10,8kW
externe Finnisch	400V ~ 3N	max. 10,8kW
externe Plug&Play Finnisch	240V ~ 3N	max. 10,8kW
Multisteuergerät	400V ~ 3N	max. 10,5kW
externe Classic Bio	400V ~ 3N	max. 9kW
externe Classic Finnisch	400V ~ 3N	max. 9kW
externe Premium Bio	400V ~ 3N	max. 12kW
externe Premium Finnisch	400V ~ 3N	max. 9kW

## Technical data

The type of oven or control unit purchased can be found in the order confirmation or delivery note. Please refer to the following list for the technical data of your units

	<b>Mains voltage</b>	<b>Wattage</b>
<b>Oven</b>		
9kW Bio	400V ~ 3N	9kW
9kW Finnisch	400V ~ 3N	9kW
9kW integrated Control unit	400V ~ 3N	9kW
4,5kW Bio	400V ~ 3N	4,5kW
4,5kW Finnisch	400V ~ 3N	4,5kW
4,5kW integrated Control unit	400V ~ 3N	4,5kW
3,6kW Bio	230V ~ 1N	3,6kW
3,6kW Finnisch	230V ~ 1N	3,6kW
3,6kW integrated Control unit	230V ~ 1N	3,6kW
<b>Control unit</b>		
External Easy Bio	400V ~ 3N	max. 10,8kW
External Plug&Play Bio	240V ~ 3N	max. 10,8kW
External Finnisch	400V ~ 3N	max. 10,8kW
External Plug&Play Finnisch	240V ~ 3N	max. 10,8kW
Multi-controller	400V ~ 3N	max. 10,5kW
External Classic Bio	400V ~ 3N	max. 9kW
External Classic Finnisch	400V ~ 3N	max. 9kW
External Premium Bio	400V ~ 3N	max. 12kW
External Premium Finnisch	400V ~ 3N	max. 9kW

## Données techniques

Dans la confirmation de commande ou le bon de livraison, vous trouverez le type de four ou l'appareil de commande que vous avez acheté. Veuillez consulter les données techniques de vos appareils dans la liste suivante

	Tension du réseau	Wattage
<b>Four</b>		
9kW Bio	400V ~ 3N	9kW
9kW Finnisch	400V ~ 3N	9kW
9kW intégré Unité de contrôle	400V ~ 3N	9kW
4,5kW Bio	400V ~ 3N	4,5kW
4,5kW Finnisch	400V ~ 3N	4,5kW
4,5kW intégré Unité de contrôle	400V ~ 3N	4,5kW
3,6kW Bio	230V ~ 1N	3,6kW
3,6kW Finnisch	230V ~ 1N	3,6kW
3,6kW intégré Unité de contrôle	230V ~ 1N	3,6kW
<b>Unité de contrôle</b>		
Externe Easy Bio	400V ~ 3N	max. 10,8kW
Externe Plug&Play Bio	240V ~ 3N	max. 10,8kW
Externe Finnisch	400V ~ 3N	max. 10,8kW
Externe Plug&Play Finnisch	240V ~ 3N	max. 10,8kW
Appareil de commande multiple	400V ~ 3N	max. 10,5kW
Externe Classic Bio	400V ~ 3N	max. 9kW
Externe Classic Finnisch	400V ~ 3N	max. 9kW
Externe Premium Bio	400V ~ 3N	max. 12kW
Externe Premium Finnisch	400V ~ 3N	max. 9kW

## Technische gegevens

Het type oven of besturingseenheid dat u hebt gekocht, vindt u in de orderbevestiging of leveringsbon. Raadpleeg de volgende lijst voor de technische gegevens van uw apparaten

	Netspanning	Wattage
<b>Oven</b>		
9kW Bio	400V ~ 3N	9kW
9kW Finnisch	400V ~ 3N	9kW
9kW geïntegreerd Besturingseenheid	400V ~ 3N	9kW
4,5kW Bio	400V ~ 3N	4,5kW
4,5kW Finnisch	400V ~ 3N	4,5kW
4,5kW geïntegreerd Besturingseenheid	400V ~ 3N	4,5kW
3,6kW Bio	230V ~ 1N	3,6kW
3,6kW Finnisch	230V ~ 1N	3,6kW
3,6kW geïntegreerd Besturingseenheid	230V ~ 1N	3,6kW
<b>Besturingseenheid</b>		
Extern Easy Bio	400V ~ 3N	max. 10,8kW
Extern Plug&Play Bio	240V ~ 3N	max. 10,8kW
Extern Finnisch	400V ~ 3N	max. 10,8kW
Extern Plug&Play Finnisch	240V ~ 3N	max. 10,8kW
Multi-controller	400V ~ 3N	max. 10,5kW
Extern Classic Bio	400V ~ 3N	max. 9kW
Extern Classic Finnisch	400V ~ 3N	max. 9kW
Extern Premium Bio	400V ~ 3N	max. 12kW
Extern Premium Finnisch	400V ~ 3N	max. 9kW

## Tekniske data

Hvilken type ovn eller styreenhed, du har købt, fremgår af ordrebekræftelsen eller følgesedlen. Se venligst følgende liste for de tekniske data for dine enheder

	<b>Netspænding</b>	<b>Wattforbrug</b>
<b>Ovn</b>		
9kW Bio	400V ~ 3N	9kW
9kW Finnisch	400V ~ 3N	9kW
9kW integreret Kontrolenhed	400V ~ 3N	9kW
4,5kW Bio	400V ~ 3N	4,5kW
4,5kW Finnisch	400V ~ 3N	4,5kW
4,5kW integreret Kontrolenhed	400V ~ 3N	4,5kW
3,6kW Bio	230V ~ 1N	3,6kW
3,6kW Finnisch	230V ~ 1N	3,6kW
3,6kW integreret Kontrolenhed	230V ~ 1N	3,6kW
<b>Kontrolenhed</b>		
Ekstern Easy Bio	400V ~ 3N	max. 10,8kW
Ekstern Plug&Play Bio	240V ~ 3N	max. 10,8kW
Ekstern Finnisch	400V ~ 3N	max. 10,8kW
Ekstern Plug&Play Finnisch	240V ~ 3N	max. 10,8kW
Multi-controller	400V ~ 3N	max. 10,5kW
Ekstern Classic Bio	400V ~ 3N	max. 9kW
Ekstern Classic Finnisch	400V ~ 3N	max. 9kW
Ekstern Premium Bio	400V ~ 3N	max. 12kW
Ekstern Premium Finnisch	400V ~ 3N	max. 9kW

## Datos técnicos

El tipo de horno o unidad de control adquirida figura en la confirmación del pedido o en el albarán de entrega. Consulte en la siguiente lista los datos técnicos de sus unidades.

	<b>Tensión de red</b>	<b>Vatios</b>
<b>Horno</b>		
9kW Bio	400V ~ 3N	9kW
9kW Finnisch	400V ~ 3N	9kW
9kW integrado Unidad de control	400V ~ 3N	9kW
4,5kW Bio	400V ~ 3N	4,5kW
4,5kW Finnisch	400V ~ 3N	4,5kW
4,5kW integrado Unidad de control	400V ~ 3N	4,5kW
3,6kW Bio	230V ~ 1N	3,6kW
3,6kW Finnisch	230V ~ 1N	3,6kW
3,6kW integrado Unidad de control	230V ~ 1N	3,6kW
<b>Unidad de control</b>		
Exterior Easy Bio	400V ~ 3N	max. 10,8kW
Exterior Plug&Play Bio	240V ~ 3N	max. 10,8kW
Exterior Finnisch	400V ~ 3N	max. 10,8kW
Exterior Plug&Play Finnisch	240V ~ 3N	max. 10,8kW
Mando múltiple	400V ~ 3N	max. 10,5kW
Exterior Classic Bio	400V ~ 3N	max. 9kW
Exterior Classic Finnisch	400V ~ 3N	max. 9kW
Exterior Premium Bio	400V ~ 3N	max. 12kW
Exterior Premium Finnisch	400V ~ 3N	max. 9kW



 **Dati tecnici**

Il tipo di forno o di unità di controllo acquistato è riportato nella conferma d'ordine o nella bolla di consegna. Per i dati tecnici delle unità, consultare il seguente elenco

	<b>Tensione di rete</b>	<b>Potenza</b>
<b>Forno</b>		
9kW Bio	400V ~ 3N	9kW
9kW Finnisch	400V ~ 3N	9kW
9kW integrato Unità di controllo	400V ~ 3N	9kW
4,5kW Bio	400V ~ 3N	4,5kW
4,5kW Finnisch	400V ~ 3N	4,5kW
4,5kW integrato Unità di controllo	400V ~ 3N	4,5kW
3,6kW Bio	230V ~ 1N	3,6kW
3,6kW Finnisch	230V ~ 1N	3,6kW
3,6kW integrato Unità di controllo	230V ~ 1N	3,6kW
<b>Unità di controllo</b>		
Esterno Easy Bio	400V ~ 3N	max. 10,8kW
Esterno Plug&Play Bio	240V ~ 3N	max. 10,8kW
Esterno Finnisch	400V ~ 3N	max. 10,8kW
Esterno Plug&Play Finnisch	240V ~ 3N	max. 10,8kW
Controllore multiplo	400V ~ 3N	max. 10,5kW
Esterno Classic Bio	400V ~ 3N	max. 9kW
Esterno Classic Finnisch	400V ~ 3N	max. 9kW
Esterno Premium Bio	400V ~ 3N	max. 12kW
Esterno Premium Finnisch	400V ~ 3N	max. 9kW

 **Technické údaje**

Typ zakoupené trouby nebo řídicí jednotky naleznete v potvrzení objednávky nebo v dodacím listu. Technické údaje vašich jednotek naleznete v následujícím seznamu

	<b>Síťové napětí</b>	<b>Příkon</b>
<b>Trouba</b>		
9kW Bio	400V ~ 3N	9kW
9kW Finnisch	400V ~ 3N	9kW
9kW integrovaný Řídicí jednotka	400V ~ 3N	9kW
4,5kW Bio	400V ~ 3N	4,5kW
4,5kW Finnisch	400V ~ 3N	4,5kW
4,5kW integrovaný Řídicí jednotka	400V ~ 3N	4,5kW
3,6kW Bio	230V ~ 1N	3,6kW
3,6kW Finnisch	230V ~ 1N	3,6kW
3,6kW integrovaný Řídicí jednotka	230V ~ 1N	3,6kW
<b>Řídicí jednotka</b>		
Externí Easy Bio	400V ~ 3N	max. 10,8kW
Externí Plug&Play Bio	240V ~ 3N	max. 10,8kW
Externí Finnisch	400V ~ 3N	max. 10,8kW
Externí Plug&Play Finnisch	240V ~ 3N	max. 10,8kW
Multi-controller	400V ~ 3N	max. 10,5kW
Externí Classic Bio	400V ~ 3N	max. 9kW
Externí Classic Finnisch	400V ~ 3N	max. 9kW
Externí Premium Bio	400V ~ 3N	max. 12kW
Externí Premium Finnisch	400V ~ 3N	max. 9kW

 **Tehnični podatki**





Vrsta kupljene pečice ali krmilne enote je navedena v potrditvi naročila ali dobavnici. Tehnične podatke vaših enot najdete na naslednjem seznamu





	<b>Omrežna napetost</b>	<b>Moč</b>
<b>Pečica</b>		
9kW Bio	400V ~ 3N	9kW
9kW Finnisch	400V ~ 3N	9kW
9kW integriran Nadzorna enota	400V ~ 3N	9kW
4,5kW Bio	400V ~ 3N	4,5kW
4,5kW Finnisch	400V ~ 3N	4,5kW
4,5kW integriran Nadzorna enota	400V ~ 3N	4,5kW
3,6kW Bio	230V ~ 1N	3,6kW
3,6kW Finnisch	230V ~ 1N	3,6kW
3,6kW integriran Nadzorna enota	230V ~ 1N	3,6kW
<b>Nadzorna enota</b>		
Zunanja stran Easy Bio	400V ~ 3N	max. 10,8kW
Zunanja stran Plug&Play Bio	240V ~ 3N	max. 10,8kW
Zunanja stran Finnisch	400V ~ 3N	max. 10,8kW
Zunanja stran Plug&Play Finnisch	240V ~ 3N	max. 10,8kW
Več krmilnikov	400V ~ 3N	max. 10,5kW
Zunanja stran Classic Bio	400V ~ 3N	max. 9kW
Zunanja stran Classic Finnisch	400V ~ 3N	max. 9kW
Zunanja stran Premium Bio	400V ~ 3N	max. 12kW
Zunanja stran Premium Finnisch	400V ~ 3N	max. 9kW





 Bitte bewahren Sie die Anleitung und den Garantieschein zur Seriennummer auf. Vernichten Sie diese erst nach Ablauf der Garantiezeit. Eventuelle Beanstandungen können mithilfe der Stückliste einfacher zugeordnet werden.





Beigelegte Dokumente:

- Informationsheft
- Garantieschein zur Seriennummer
- Typenschild inkl. Warnhinweise (Sauna)
- ggf. Zubehör-Anleitungen in externen Paketen

- \*  Nicht im Lieferumfang enthalten  
 Not included  
 Non comprises dans la livraison  
 Niet bijgeleverd

-  No forman parte del suministro  
 Non incluso  
 V ceně není zahrnuto  
 Ikke inkluderet

- 1  Länge muss ermittelt und zugesägt werden  
 Length must be determined and sawn  
 La longueur doit être déterminée et sciée  
 De lengte moet worden bepaald en worden gezaagd

-  La longitud debe ser determinada y aserrada  
 La lunghezza deve essere determinata e segata  
 Délka musí být určena a rozřezána  
 Længden skal bestemmes og saves

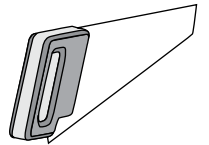
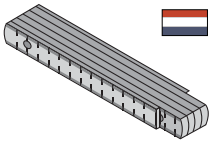

- 2  Nicht gebraucht  
 Not needed  
 Pas nécessaire  
 Niet nodig



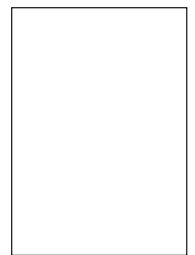

-  No es necesario  
 Non necessario  
 Není nutná

- 3  mit Zubehör!  
 met toebehoren!  
 with accessories!  
 avec accessoires!





-  con accesorios!  
 con accessori!  
 s příslušenstvím!  
 z dodatki!



- 4  Fixiert vorübergehend  
 tijdelijk vast  
 Fixed temporarily  
 temporairement fixe

-  temporalmente fijo  
 temporaneamente fisso  
 dočasně pevný  
 Zčasno pritrjeno

- 5  Bestand vom Haus  
 Inventaris van het huis  
 Inventory of the house  
 Inventaire de la maison

-  Inventario de la casa  
 Inventario della casa  
 Inventář domu  
 Inventar hiše





Vergleichen Sie zuerst die Material-liste mit Ihrem Paketinhalt! Bitte haben Sie Verständnis, dass Beanstandungen nur im nicht aufgebauten Zustand bearbeitet werden können!



Vergelijk eerst de lijst van materialen met de inhoud van uw pakket! Reclamaties kunnen alleen in behandeling worden genomen zolang de onderdelen nog niet zijn gemonteerd!



Confrontate questa distinta materiali prima con il contenuto del pacchetto! Vi preghiamo di comprendere che eventuali reclami possono essere accolti solo prima del montaggio!



First compare the list of materials with your package contents! Please understand that complaints can be processed in the non-built status only!



Start med at kontrollere materialelisten med indholdet af den leverede pakke! Vi gør venligst opmærksom på at reklamationer kun kan behandles for materialer som ikke er blevet bearbejdet!



Nejprve přezkontrolujte obsah balení podle materiálového listu! Mějte pochopení pro to, že případnou reklamaci se můžeme zabývat pouze tehdy, když díly nebudou smontované! Za pomoci tohoto seznamu můžete jednotlivé díly přiřadit k montážnímu návodu.



Commencez par comparer la liste du matériel avec le contenu de votre paquet! Sachez que nous traitons uniquement les réclamations concernant le matériel à l'état non monté!



En primer lugar, compare la lista de material con el contenido del paquete. Rogamos entienda que las reclamaciones sólo pueden ser tramitadas antes de montar el objeto!

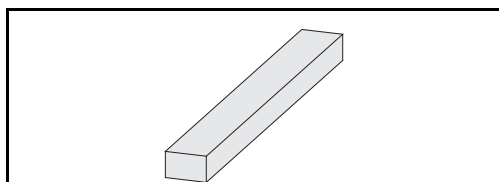
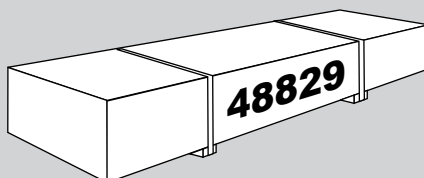

2 x <b>B1</b>	2085 x 38 x 18 mm	ID 51802
2 x <b>B2</b>	1998 x 95 x 18 mm	ID 48810
2 x <b>B3</b>	2059 x 95 x 18 mm	ID 48809
4 x <b>B4</b>	2390 x 95 x 18 mm	ID 43530
4 x <b>B5</b>	2390 x 120 x 18 mm	ID 60803
4 x <b>B6</b>	2953 x 120 x 18 mm	ID 63287
9 x <b>B7</b>	2970 x 140 x 26 mm	ID 15541
2 x <b>B8</b>	2010 x 45 x 38 mm	ID 57783
5 x <b>B9</b>	2916 x 60 x 40 mm	ID 48823
2 x <b>B10</b>	3035 x 60 x 40 mm	ID 48824
6 x <b>B11</b>	2400 x 45 x 45 mm	ID 48811
2 x <b>B12</b>	2880 x 45 x 45 mm	ID 48812

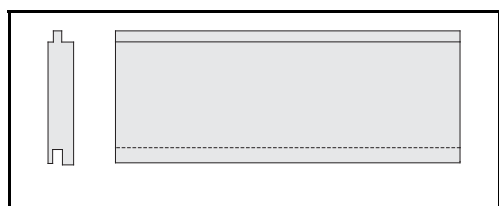

68 x <b>R1</b>	2970 x 96 x 19 mm	ID 79161
----------------	-------------------	----------

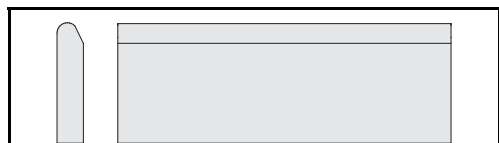

2 x <b>R2</b>	2000 x 58 x 17 mm	ID 62242
---------------	-------------------	----------

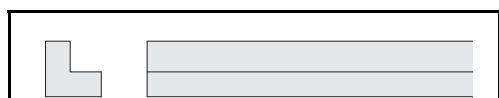

1 x <b>R3</b>	1997 x 45 x 45 mm	ID 74594
---------------	-------------------	----------

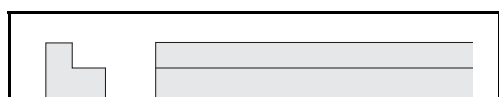

4 x <b>R4</b>	2042 x 45 x 45 mm	ID 74218
---------------	-------------------	----------

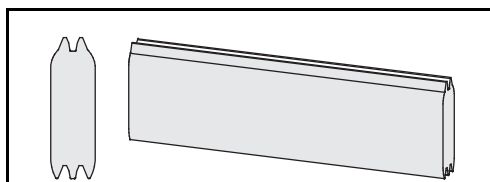

38 x <b>W1</b>	923 x 121 x 40 mm	ID 48825
19 x <b>W2</b>	1923 x 121 x 40 mm	ID 48826
48 x <b>W3</b>	2970 x 121 x 40 mm	ID 67538

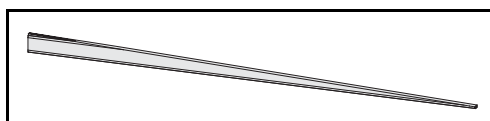

1 x <b>W4</b>	2970 x 93 x 40 mm	ID 52417
---------------	-------------------	----------

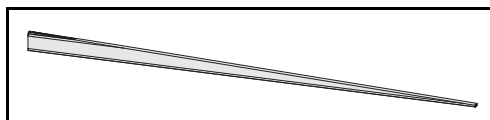

1 x <b>W5</b>	2970 x 93 x 40 mm	ID 52348
---------------	-------------------	----------

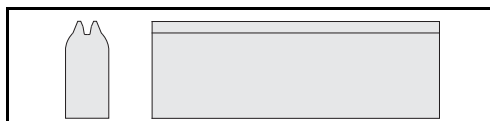

1 x <b>W6</b>	1047 x 80 x 40 mm	ID 51831
2 x <b>W7</b>	2047 x 80 x 40 mm	ID 51825

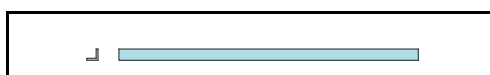

6 x <b>M1</b>	1600 x 30 x 30 mm	ID 61695
---------------	-------------------	----------

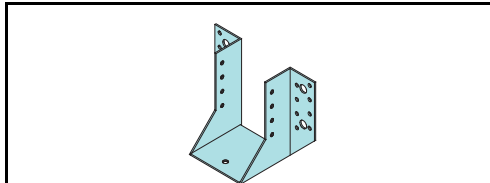

6 x		ID 33143
-----	--	----------

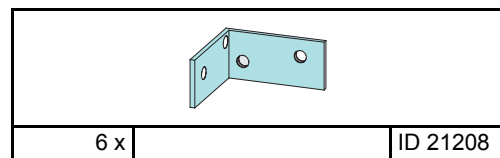

6 x		ID 21208
-----	--	----------

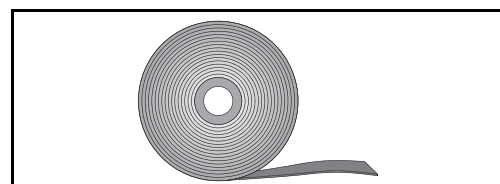

2 x	10 m	ID 14025
-----	------	----------

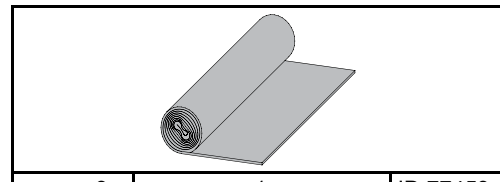

3 x	1 m	ID 77453
-----	-----	----------

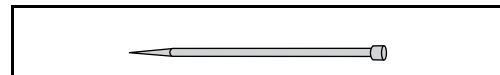

670 x	2 x 50 mm	ID 5621
-------	-----------	---------

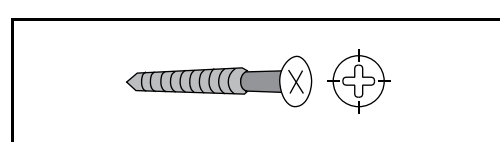

78 x	4 x 35 mm	ID 3687
205 x	4 x 50 mm	ID 3688
20 x	4,5 x 80 mm	ID 9204
400 x	5 x 70 mm	ID 93009



Vergleichen Sie zuerst die Material-liste mit Ihrem Paketinhalt! Bitte haben Sie Verständnis, dass Beanstandungen nur im nicht aufgebauten Zustand bearbeitet werden können!



Vergelijk eerst de lijst van materialen met de inhoud van uw pakket! Reclamaties kunnen alleen in behandeling worden genomen zolang de onderdelen nog niet zijn gemonteerd!



Confrontate questa distinta materiali prima con il contenuto del pacchetto! Vi preghiamo di comprendere che eventuali reclami possono essere accolti solo prima del montaggio!



First compare the list of materials with your package contents! Please understand that complaints can be processed in the non-built status only!



Start med at kontrollere materialelisten med indholdet af den leverede pakke! Vi gør venligst opmærksom på at reklamationer kun kan behandles for materialer som ikke er blevet bearbejdet!



Nejprve přezkontrolujte obsah balení podle materiálového listu! Mějte pochopení pro to, že případnou reklamaci se můžeme zabývat pouze tehdy, když díly nebudou smontované! Za pomoci tohoto seznamu můžete jednotlivé díly přiřadit k montážnímu návodu.



Commencez par comparer la liste du matériel avec le contenu de votre paquet! Sachez que nous traitons uniquement les réclamations concernant le matériel à l'état non monté!



En primer lugar, compare la lista de material con el contenido del paquete. Rogamos entienda que las reclamaciones sólo pueden ser tramitadas antes de montar el objeto!

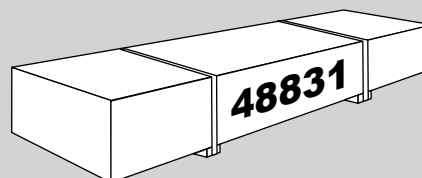
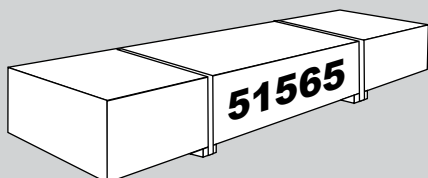

2 x **Z1** | 2000 x 32 x 63 mm

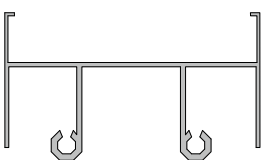

1 x **Z2** | 1962 x 35 x 60 mm

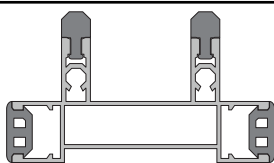

1 x **Z3** | 1962 x 35 x 60 mm

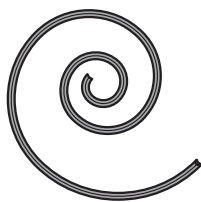

1 x



1 x **Z5** | 2000 x 1000 x 40 mm



1 x **Z7** | 51565 1000 x 40 mm | ID 48831

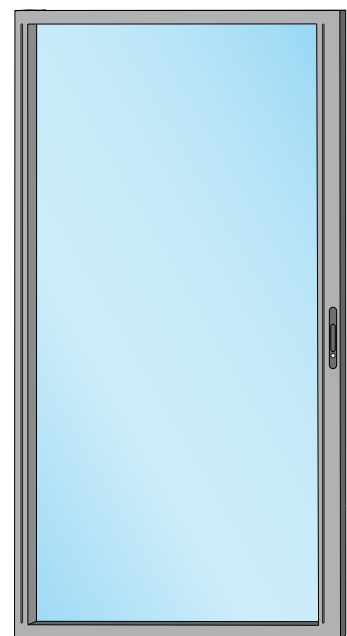

1 x **Z6** | 2000 x 1000 x 40 mm



4 x | 4,2 x 50 mm



10 x | 4,2 x 50 mm



16 x | 4,8 x 32 mm

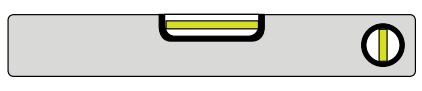

Ø3 mm 4,5×80

8x

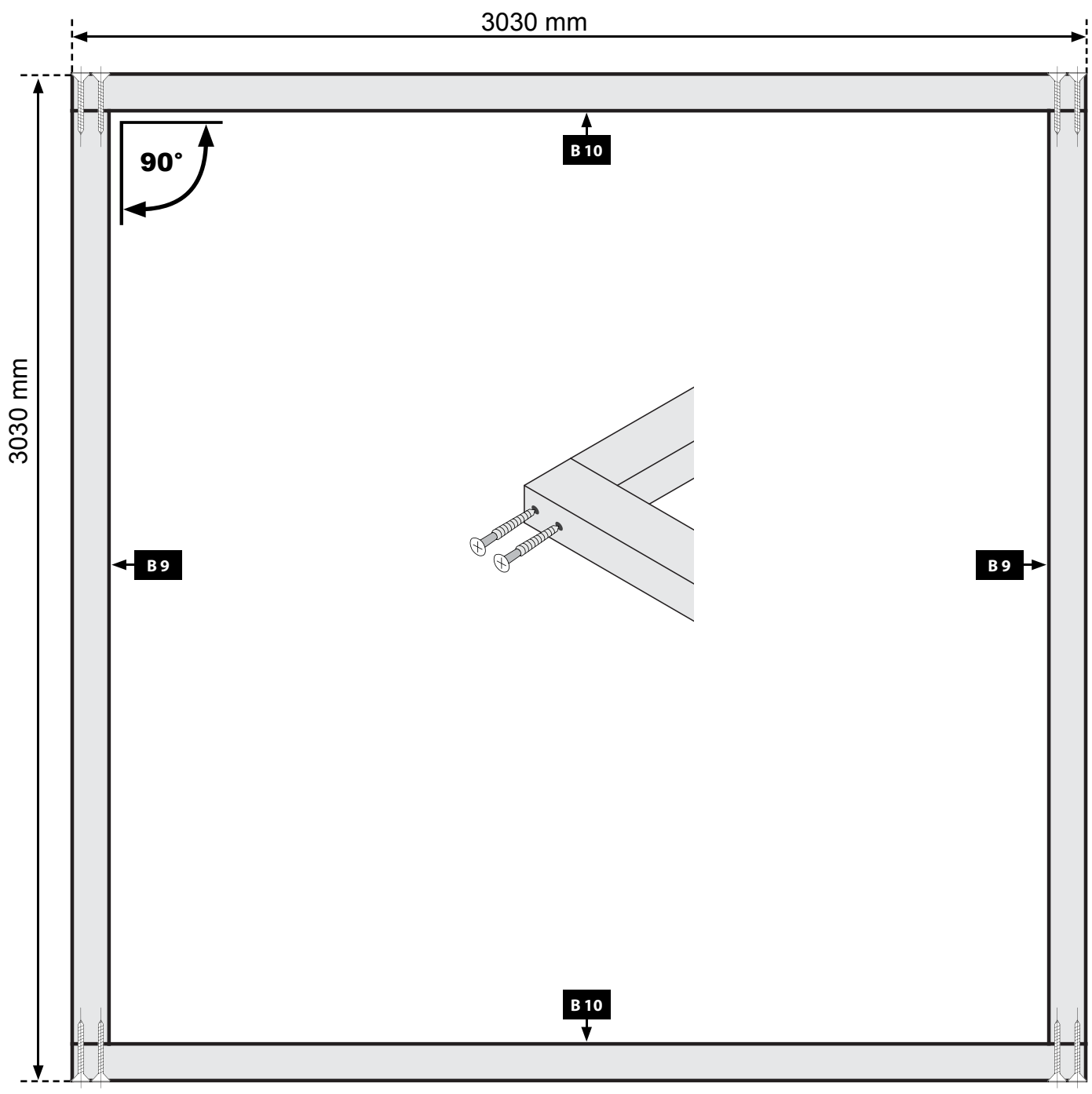
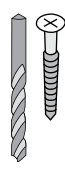



Ø3 mm 4,5×80

12x

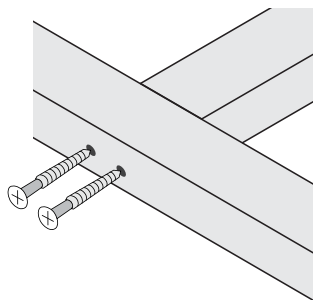
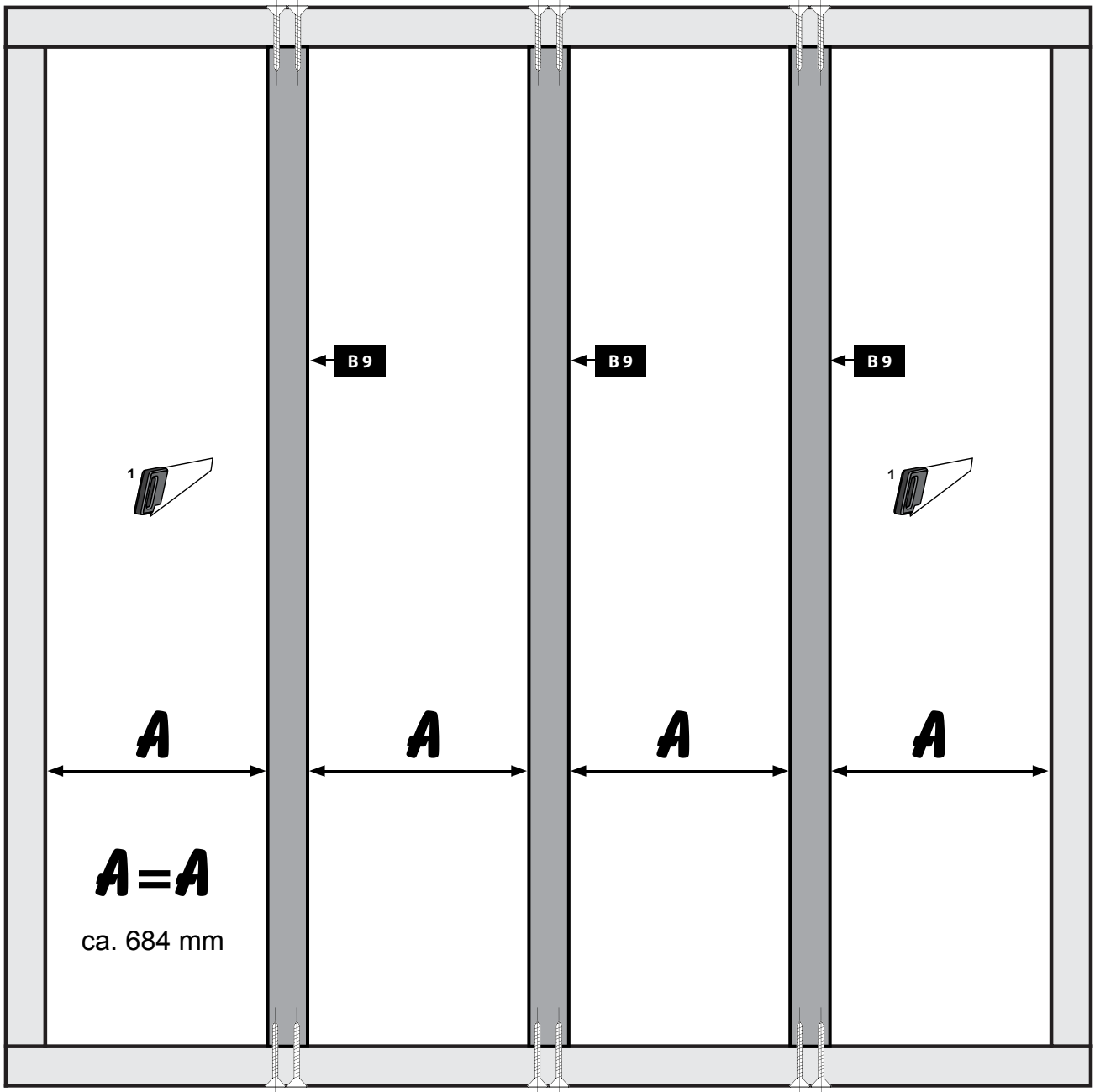
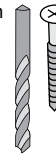



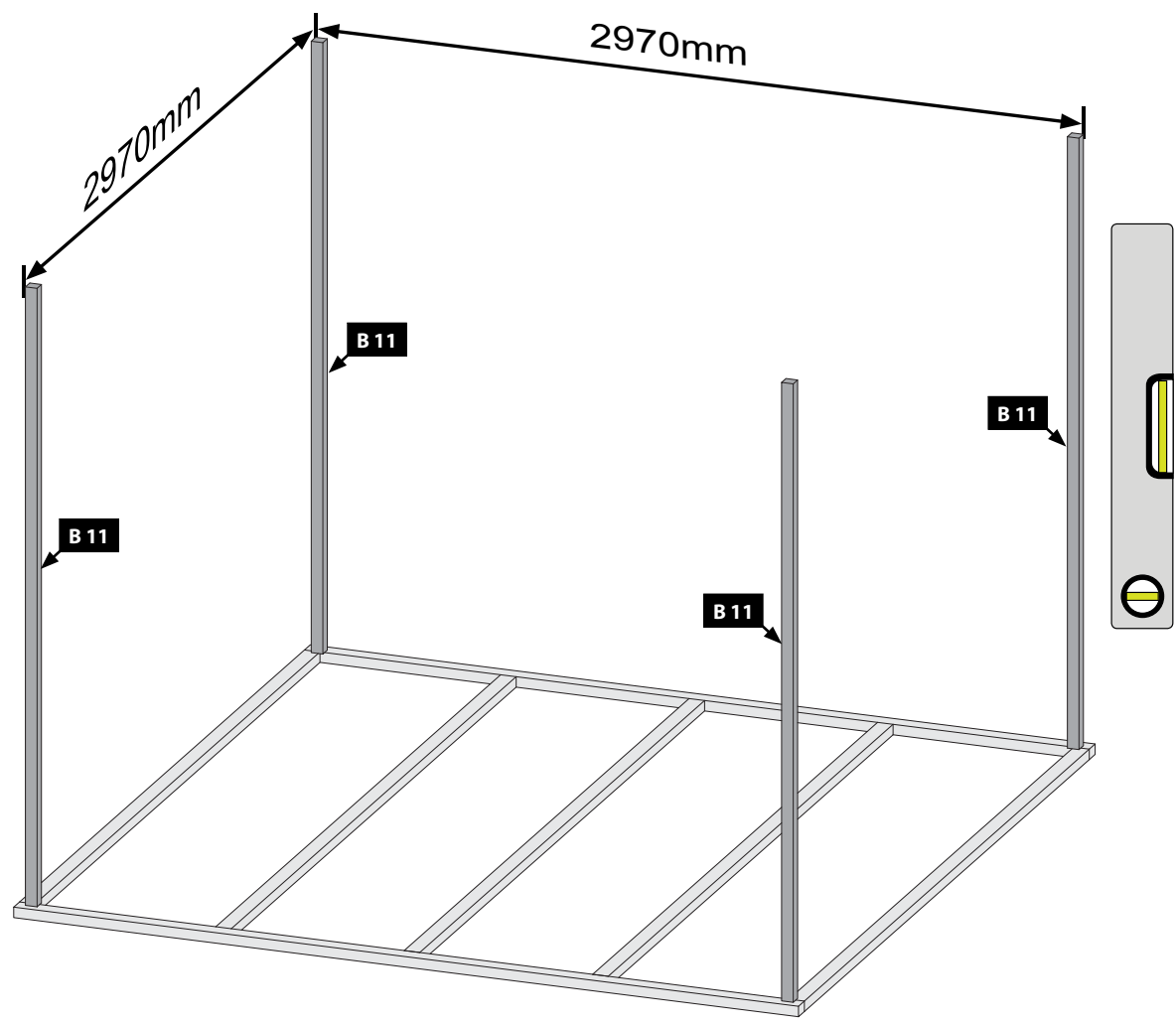

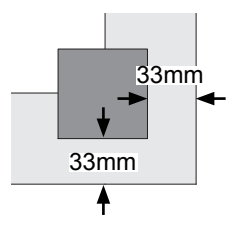
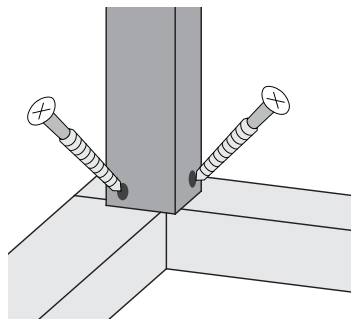

Ø3mm 4x50

8x



 Leim! Achten Sie auf die gleiche Höhe

 Glue! Look for the same height

 Colle! Faites attention à la même hauteur

 Lijm! Besteed aandacht aan de dezelfde hoogte

 Lim! Vær opmærksom på samme højde

 Pegamento! Prestar atención a la misma altura

 Colla! Prestare attenzione alla stessa altezza

 Klíh! Dávejte pozor na stejnou výšku

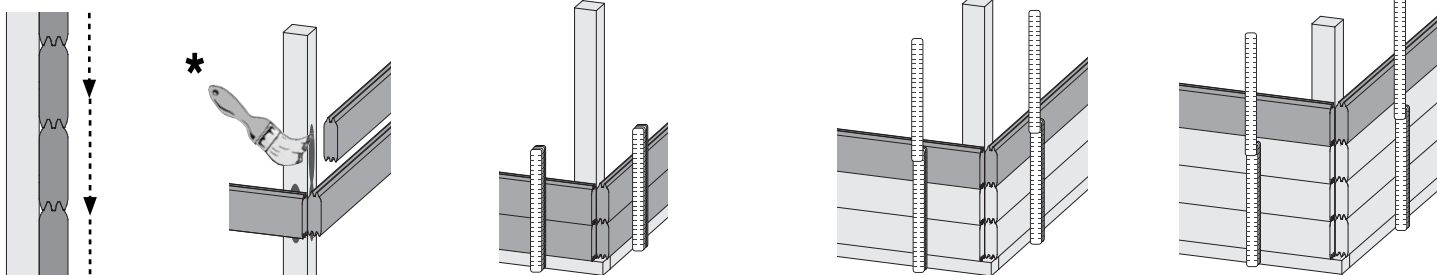

04

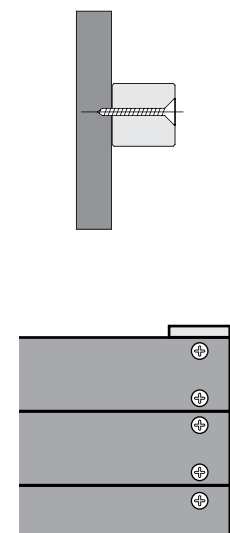
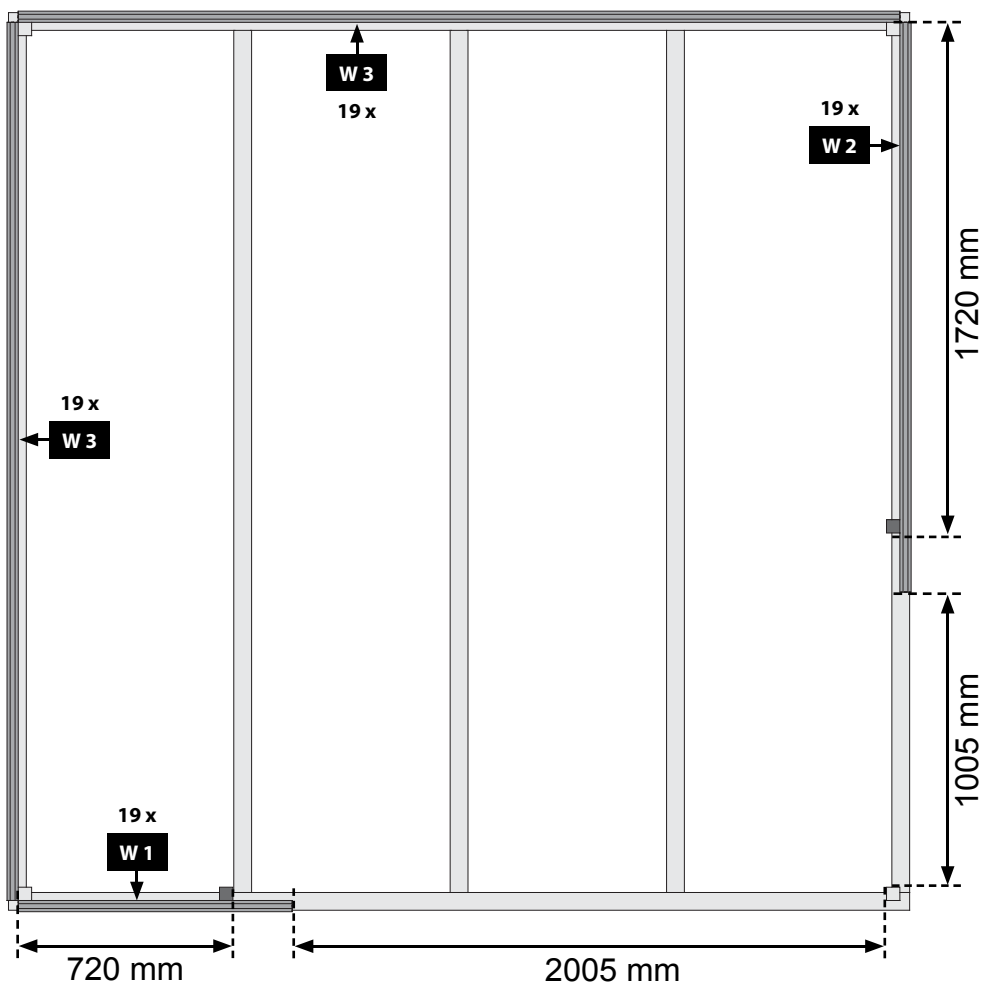
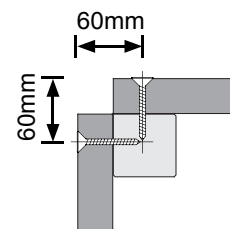
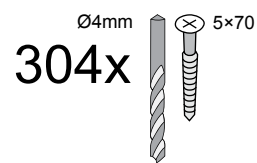
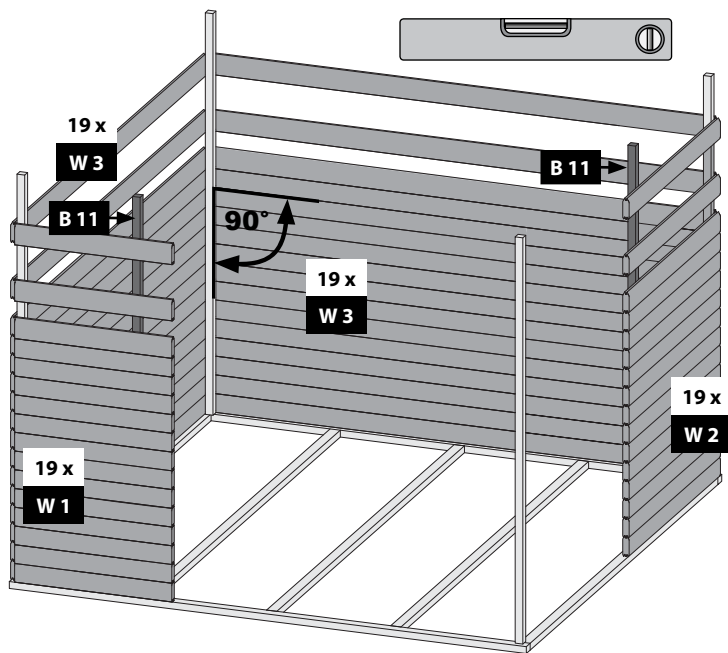

05

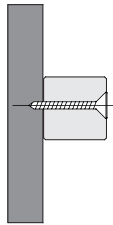
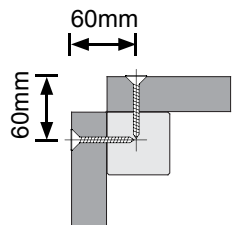
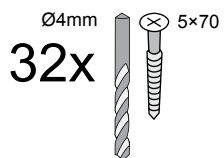
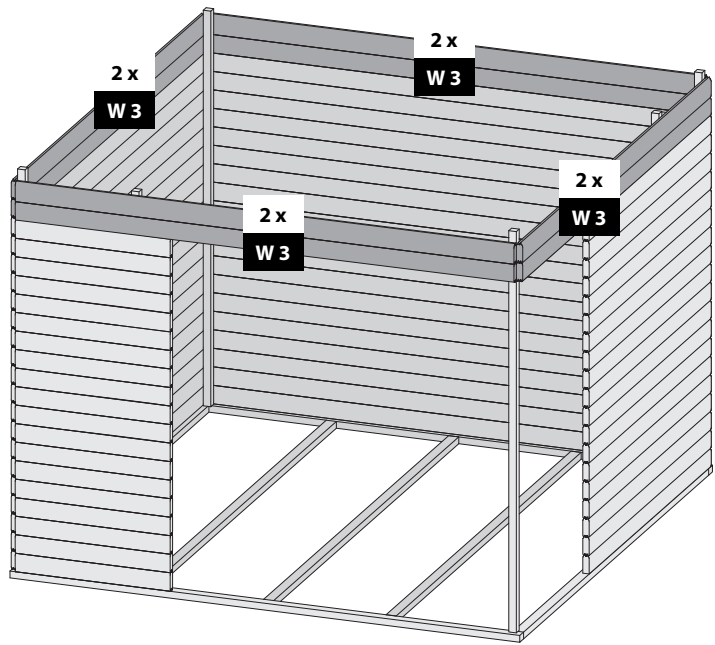

06

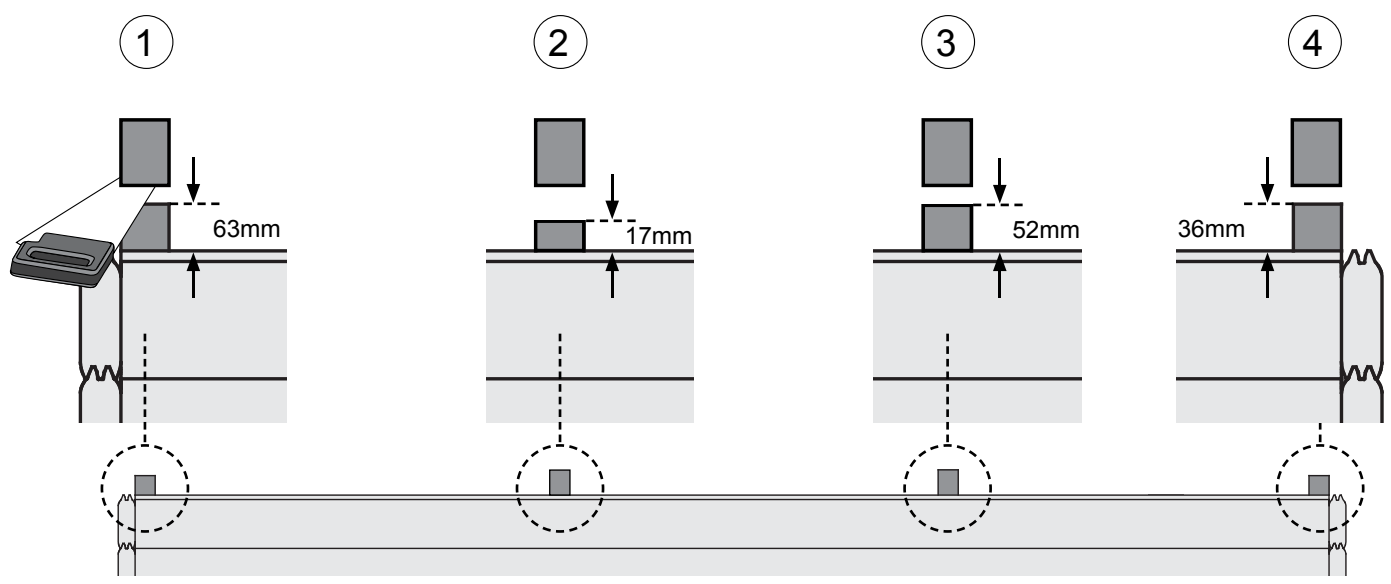
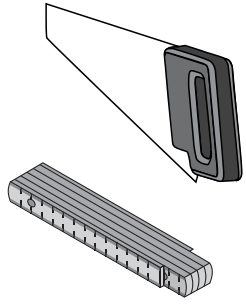
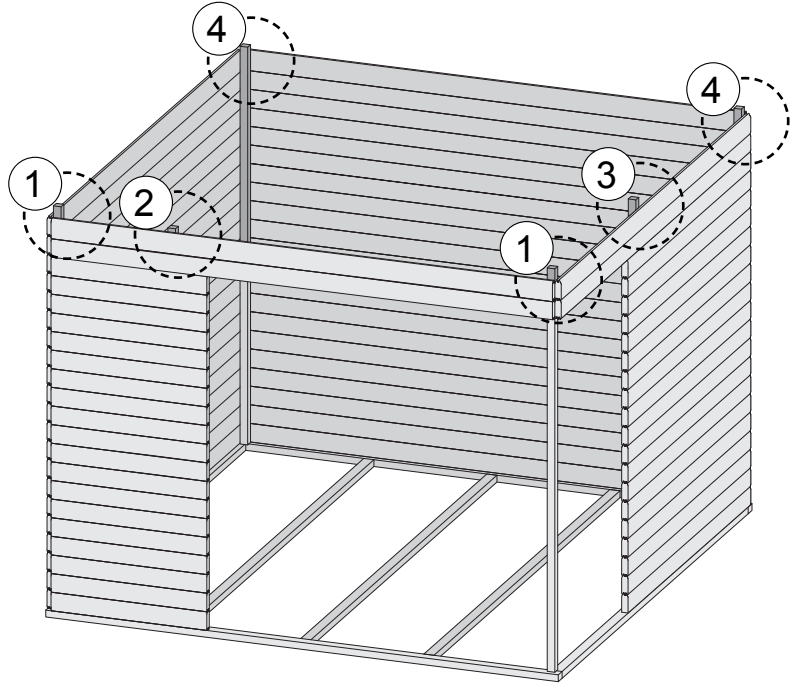

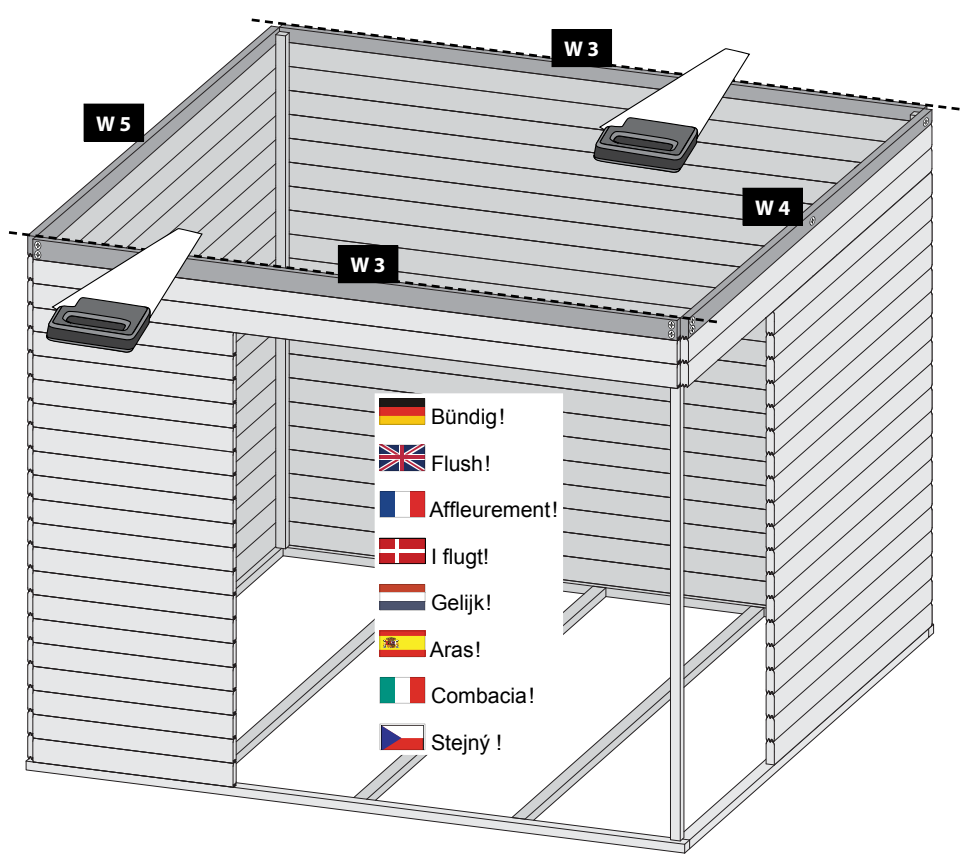

-  Bündig!
-  Flush!
-  Affleurement!
-  I flugt!
-  Gelijk!
-  Aras!
-  Combacia!
-  Stejný !

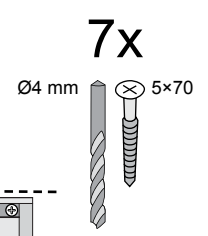
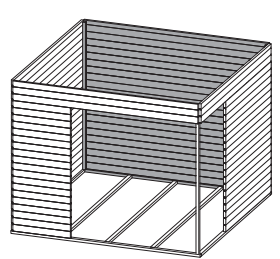
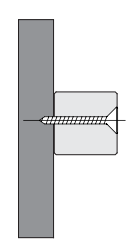
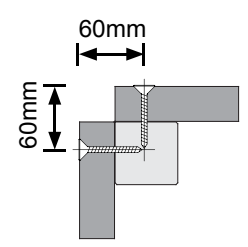
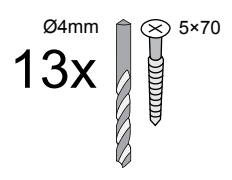

-  Bündig!
-  Flush!
-  Affleurement!
-  I flugt!
-  Gelijk!
-  Aras!
-  Combacia!
-  Stejný !

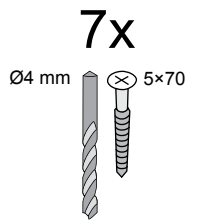
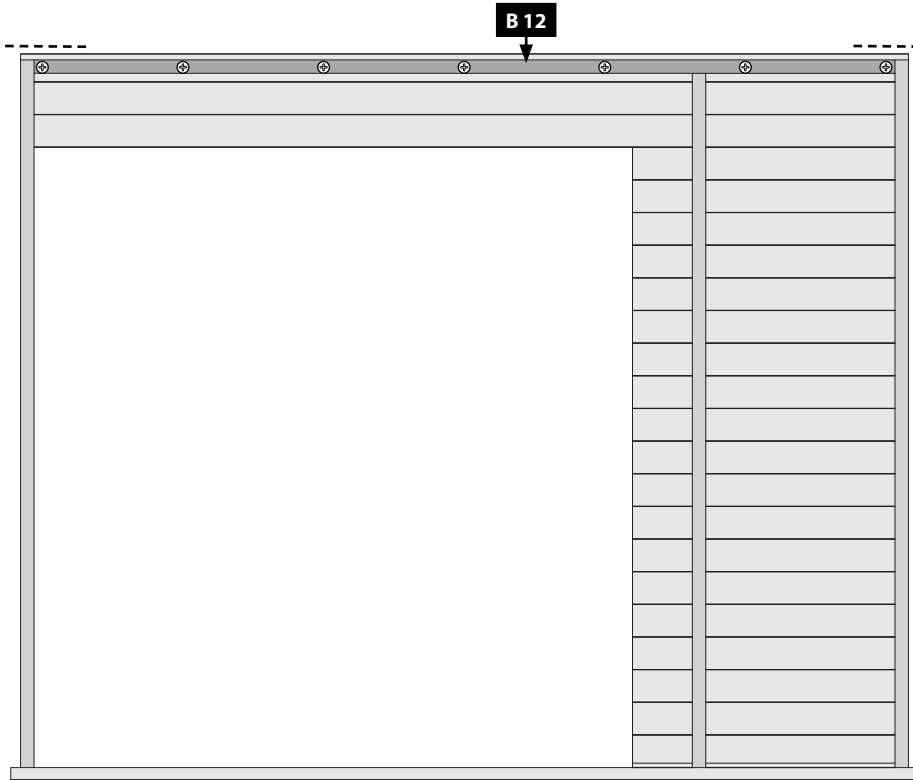
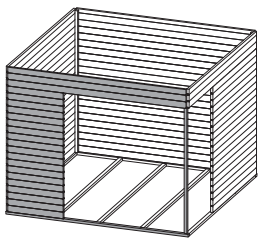

-  Bündig!
-  Flush!
-  Affleurement!
-  I flugt!
-  Gelijk!
-  Aras!
-  Combacia!
-  Stejný !

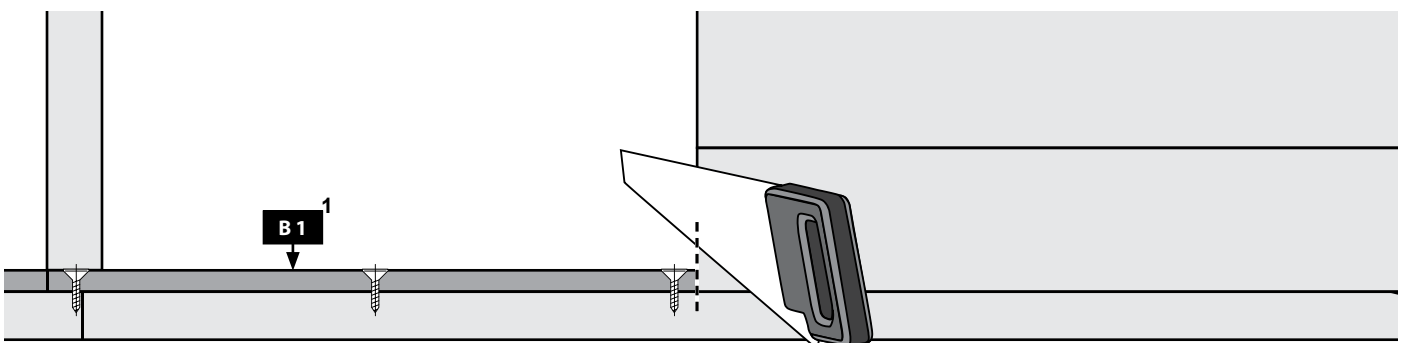
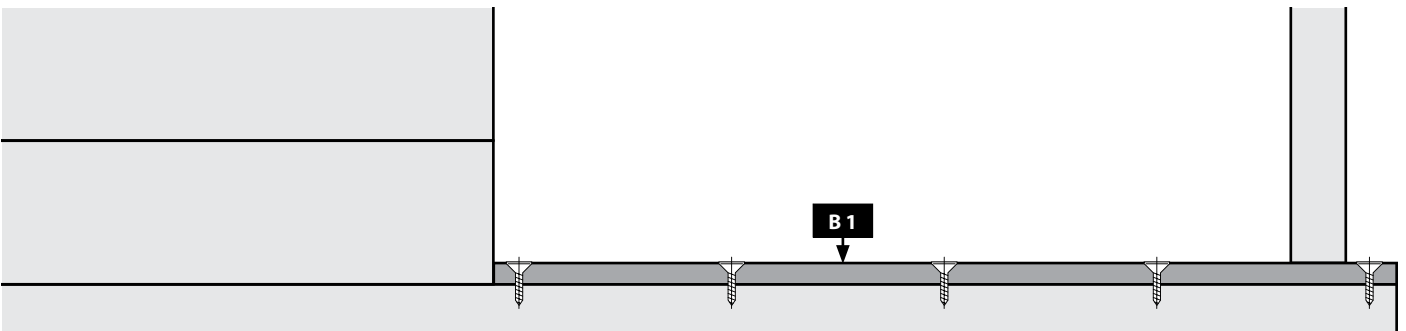
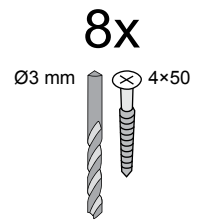
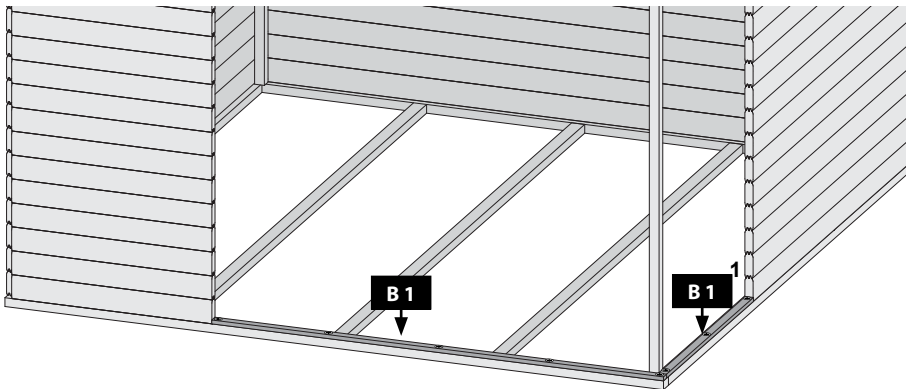

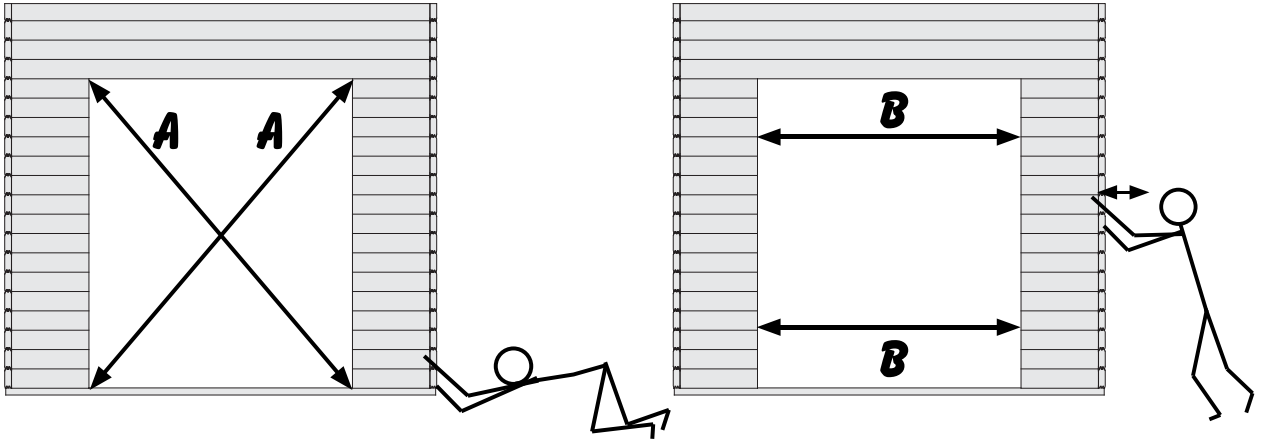

11

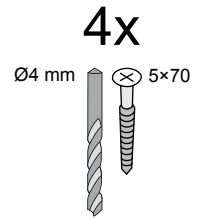
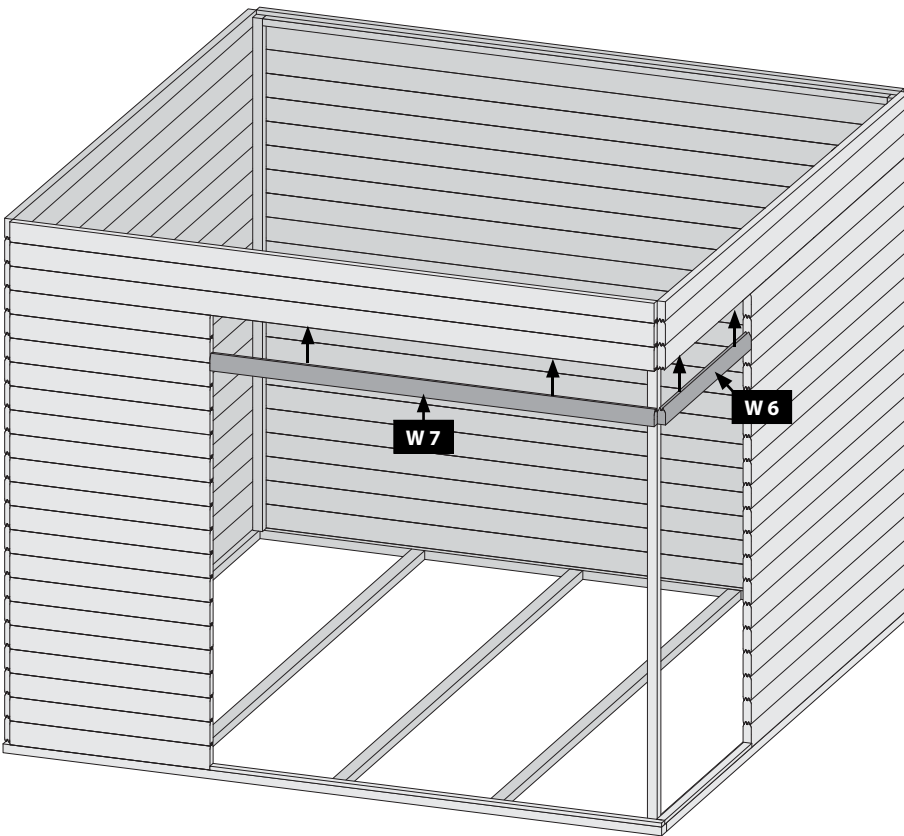

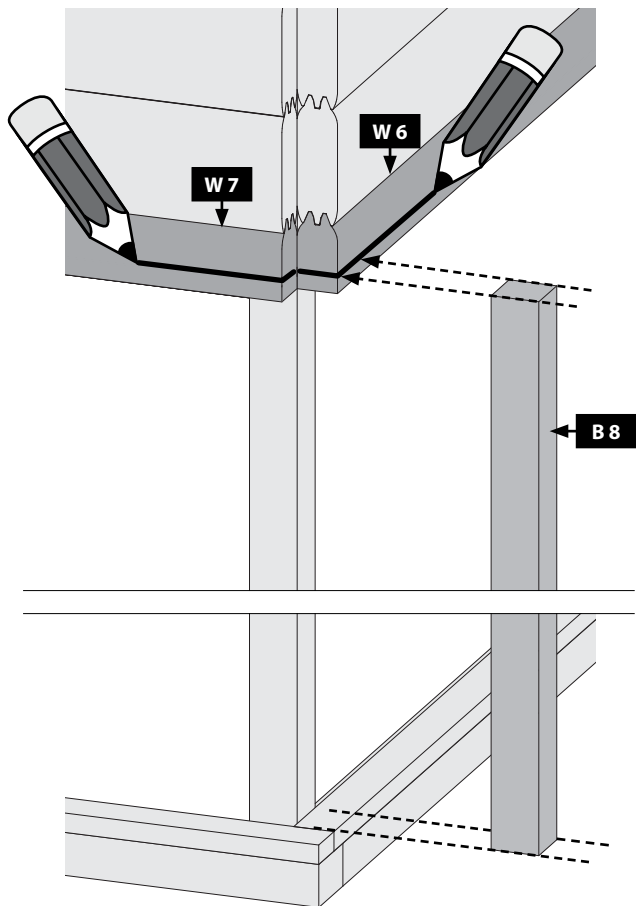

-  Bündig!
-  Flush!
-  Affleurement!
-  I flugt!
-  Gelijk!
-  Aras!
-  Combacia!
-  Stejný !

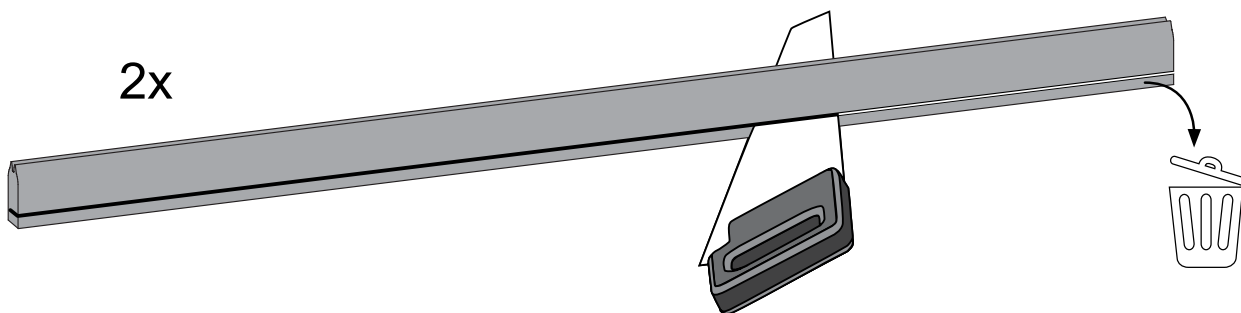
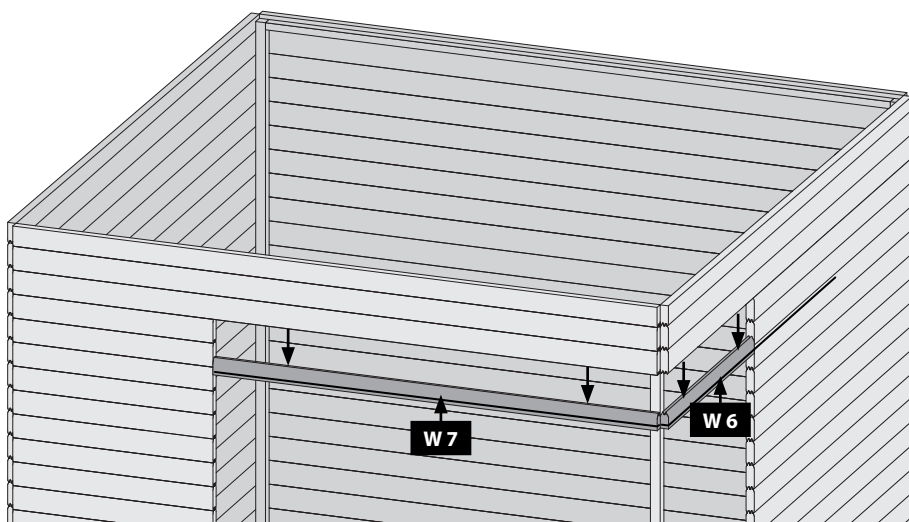

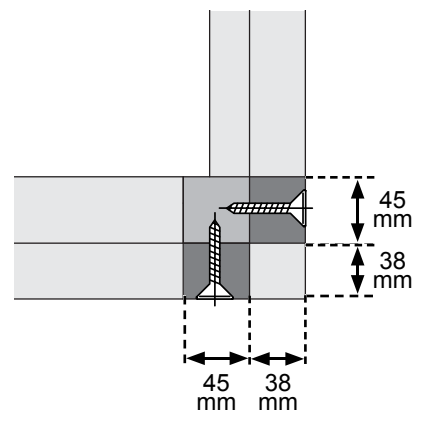
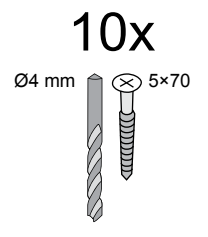
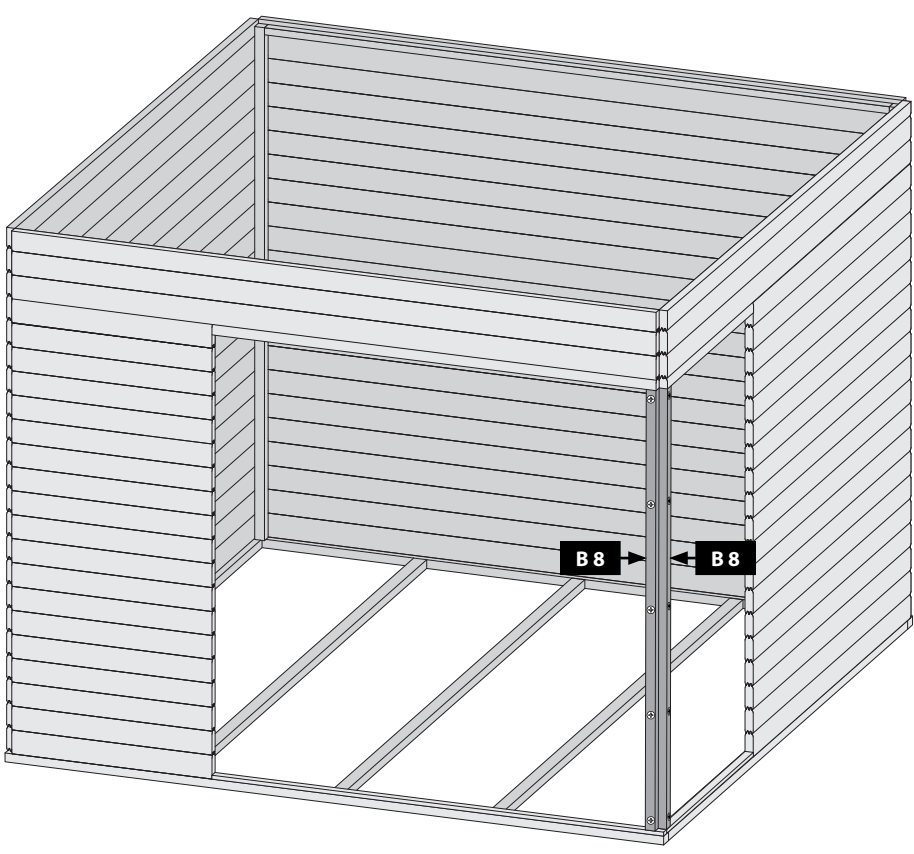
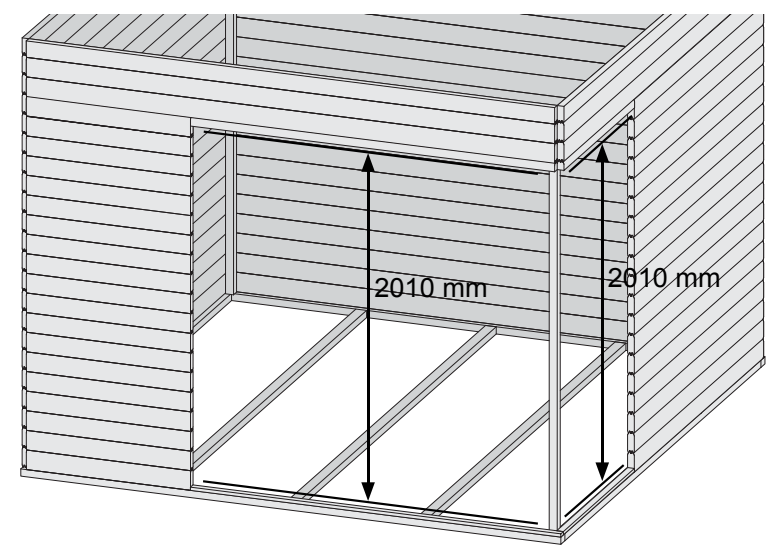
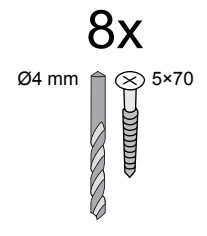
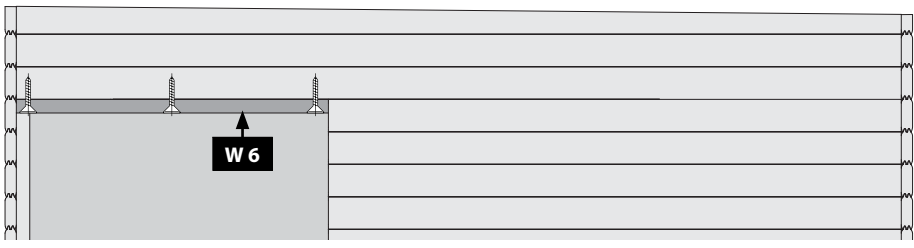
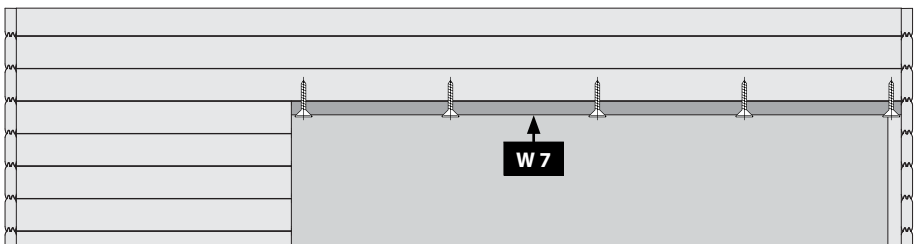



78x

3x

Ø3 mm 4x50

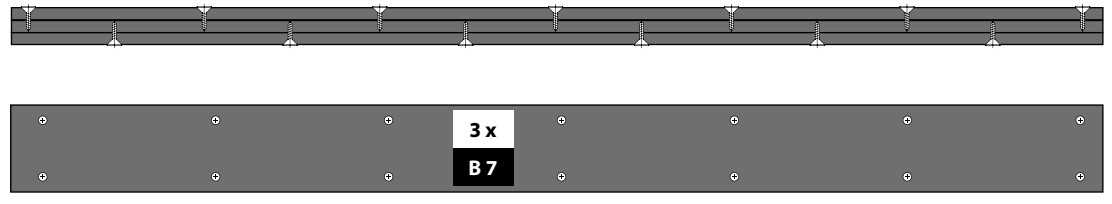
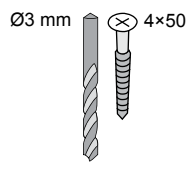



78x

6x

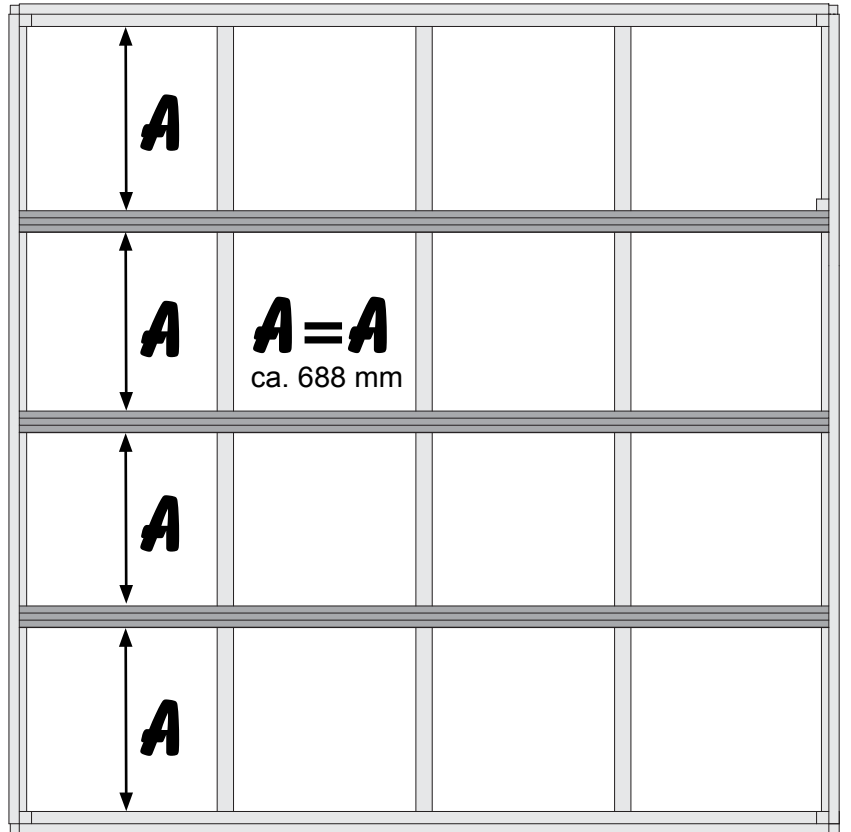
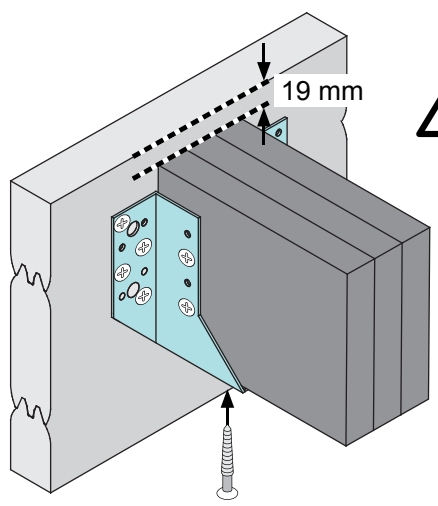
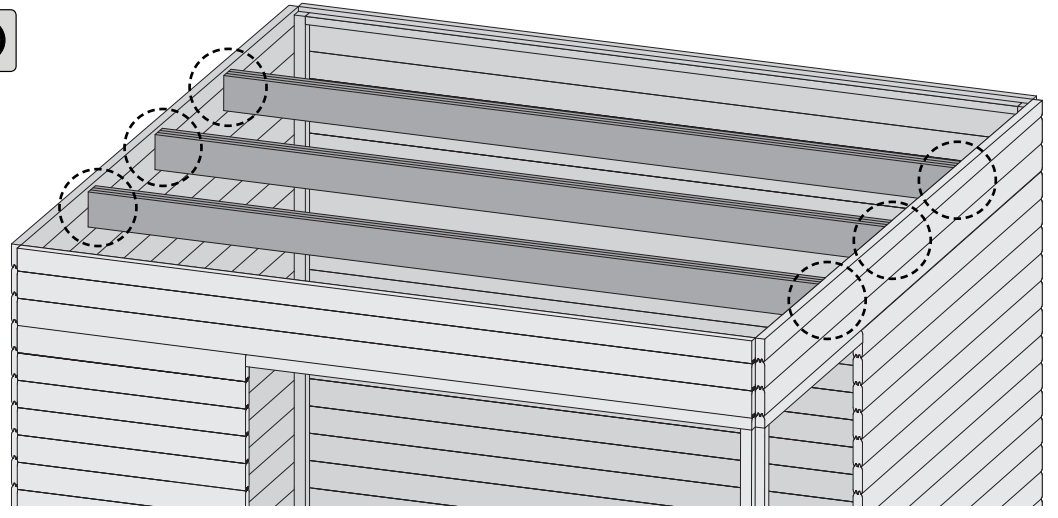
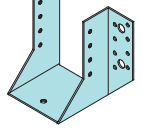
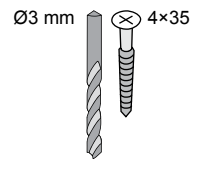
Ø3 mm 4x35

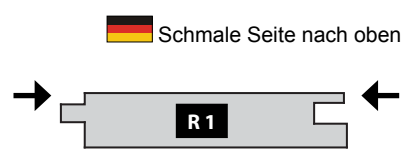
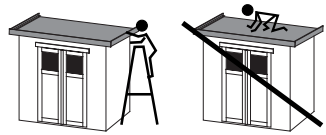





 Schmale Seite nach oben

 Narrow side up

 Estrecha hacia arriba

 Narrow vers le haut

 Stretta verso l'alto

 Smalle kant naar boven

 Úzká stranou nahoru

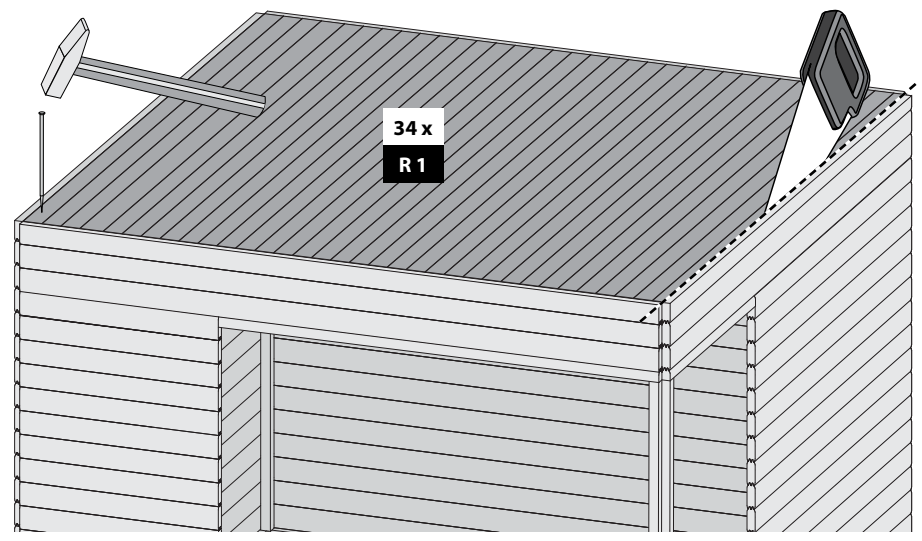

~335x

 Bündig!

 Flush!

 Affleurement!

 I flugt!

 Gelijk!

 Aras!

 Combacia!



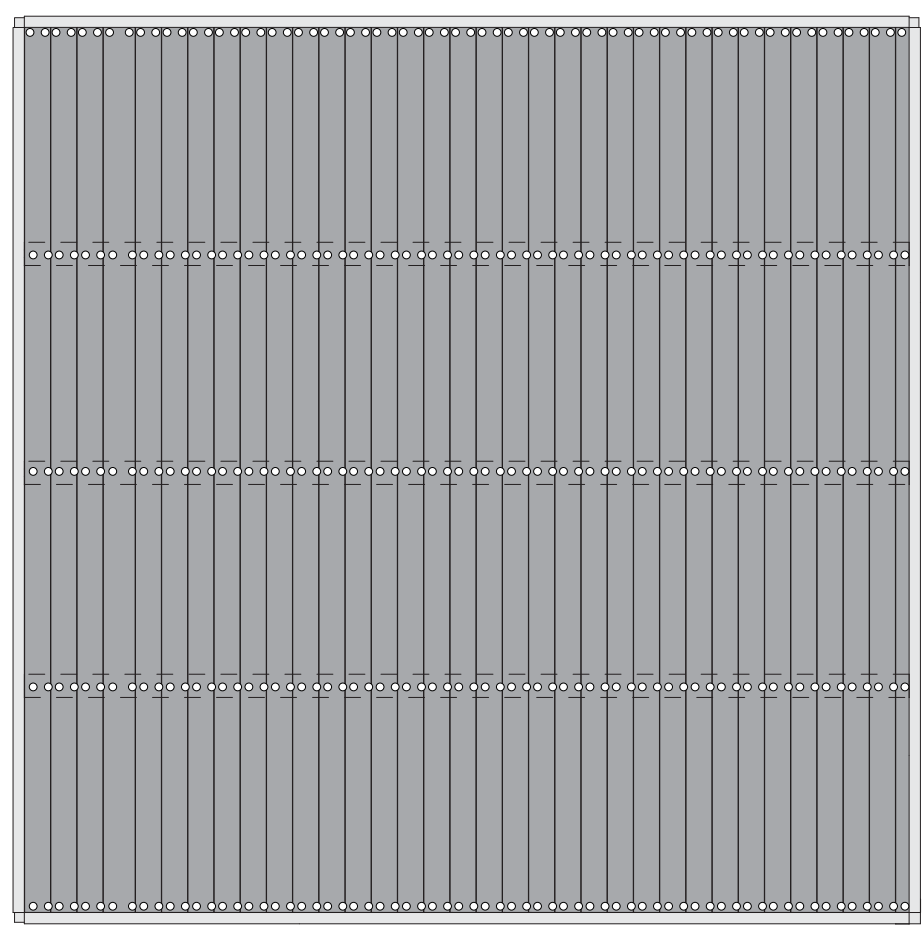
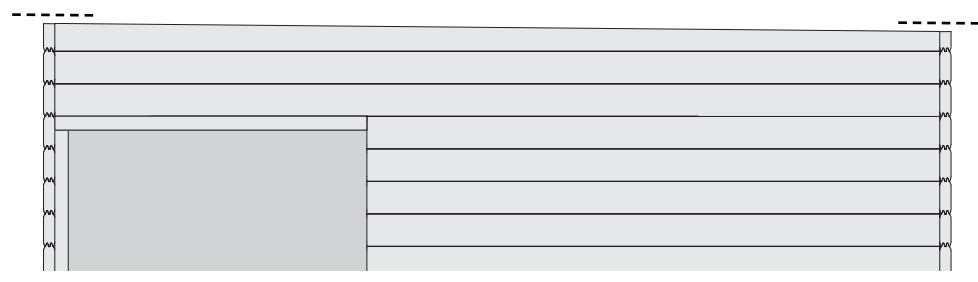

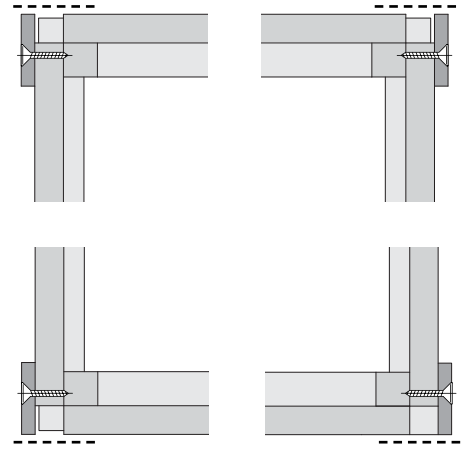
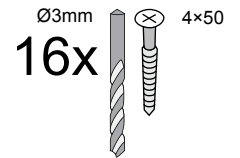
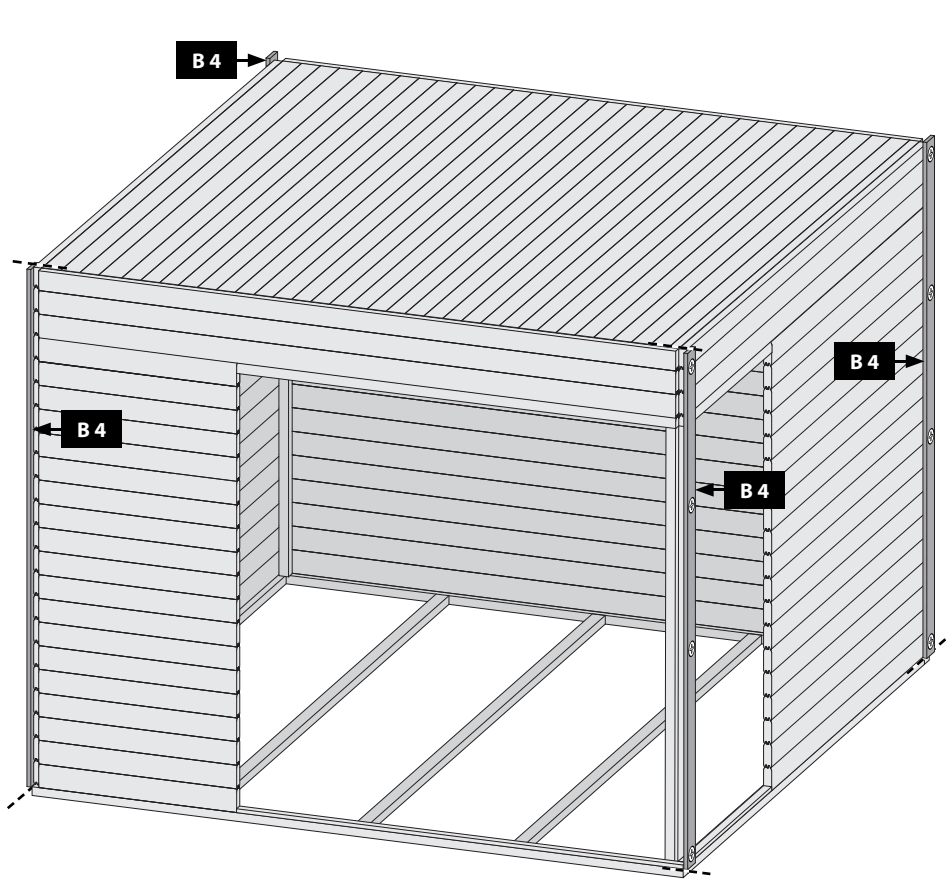
 Stejný !



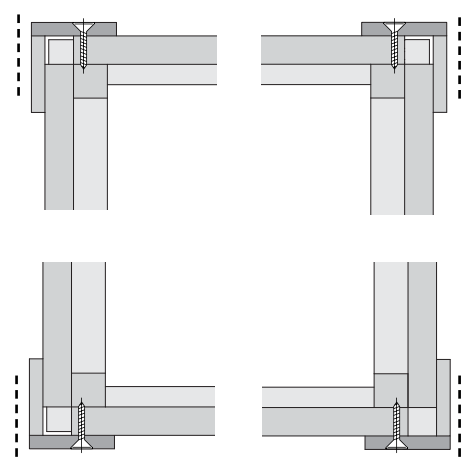
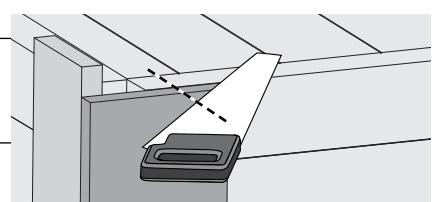
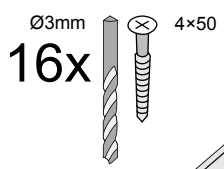
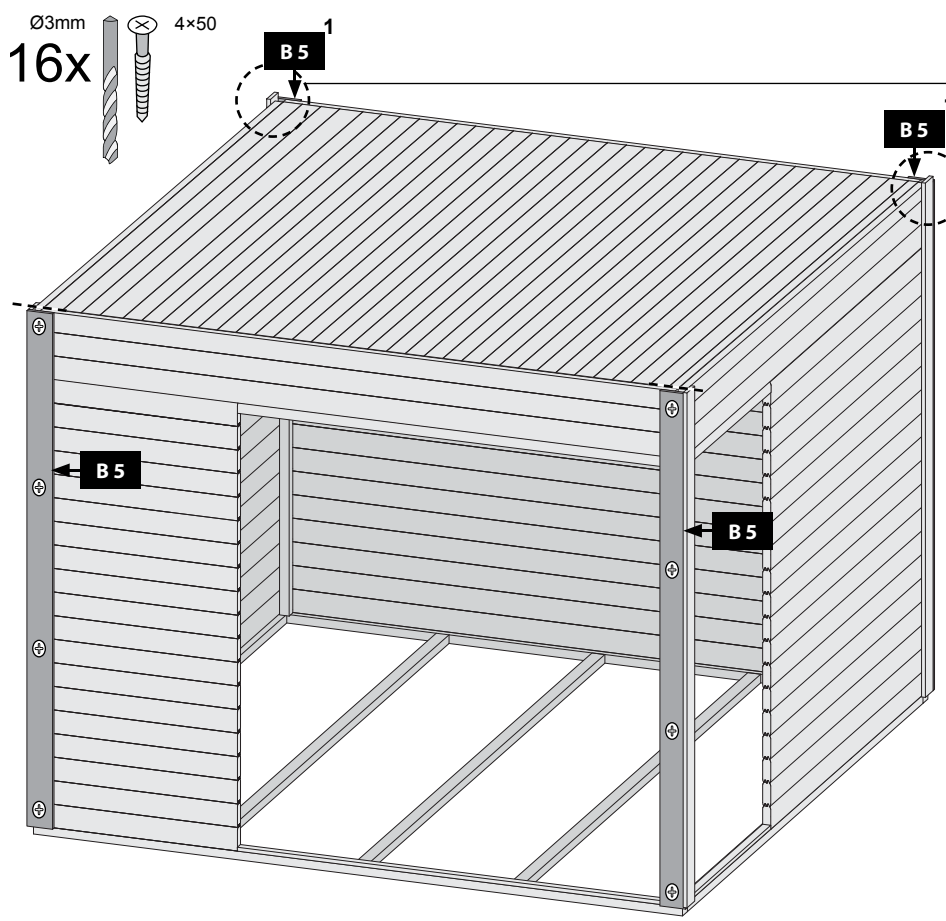

-  Bündig!
-  Gelijk!
-  Flush!
-  Aras!
-  Affleurement!
-  Combacia!
-  I flugt!
-  Stejný !



-  Bündig!
-  Gelijk!
-  Flush!
-  Aras!
-  Affleurement!
-  Combacia!
-  I flugt!
-  Stejný !

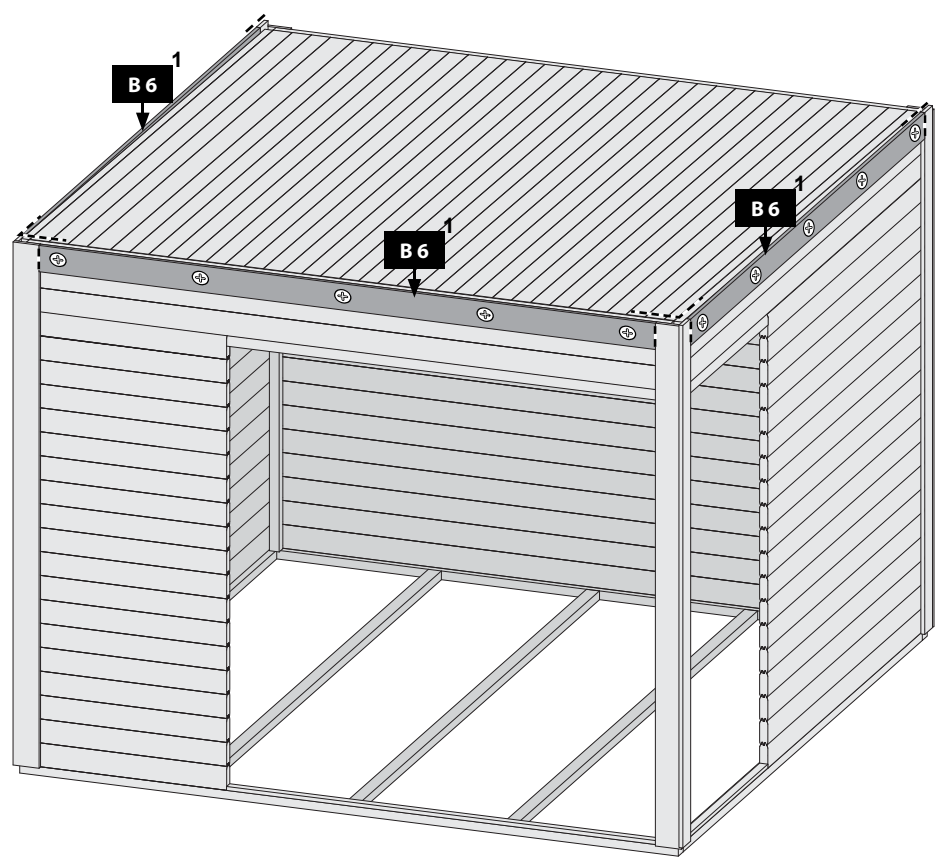
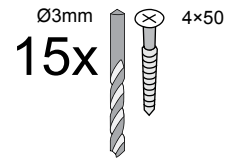

-  Bündig!
-  Flush!
-  Affleurement!
-  I flugt!
-  Gelijk!
-  Aras!
-  Combacia!
-  Stejný !

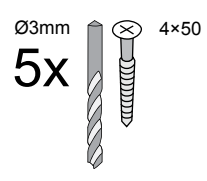

-  Bündig!
-  Flush!
-  Affleurement!
-  I flugt!
-  Gelijk!
-  Aras!
-  Combacia!
-  Stejný !

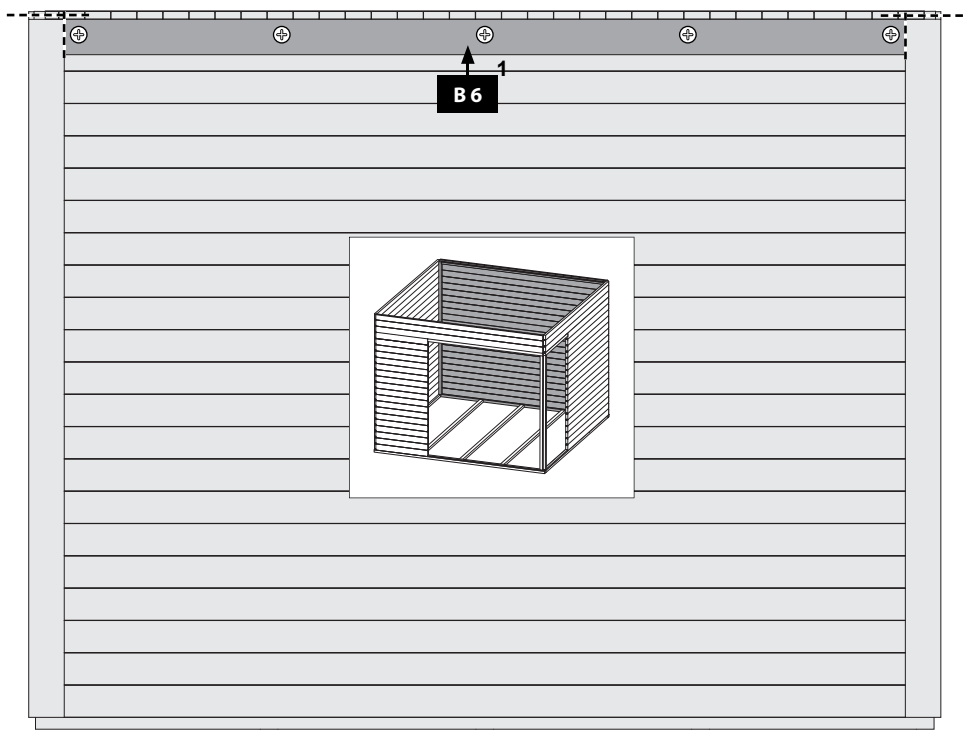

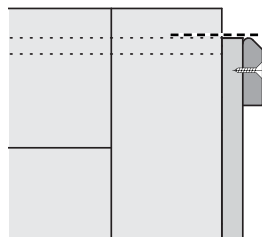
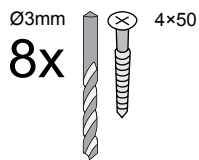

-  Bündig!
-  Flush!
-  Affleurement!
-  I flugt!
-  Gelijk!
-  Aras!
-  Combacia!
-  Stejný !

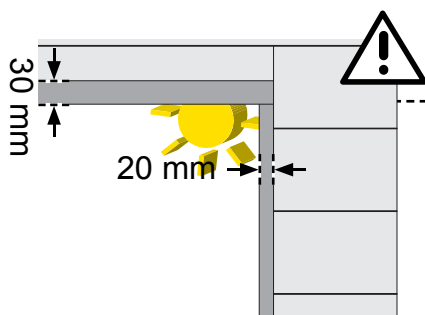
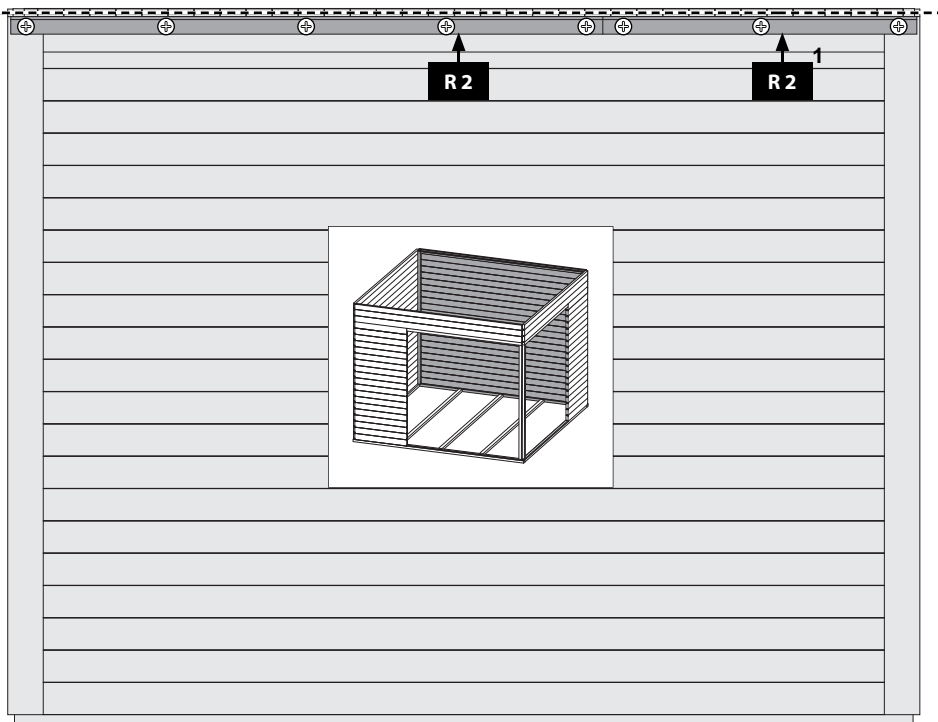

-  Bündig!
-  Flush!
-  Affleurement!
-  I flugt!
-  Gelijk!
-  Aras!
-  Combacia!
-  Stejný !

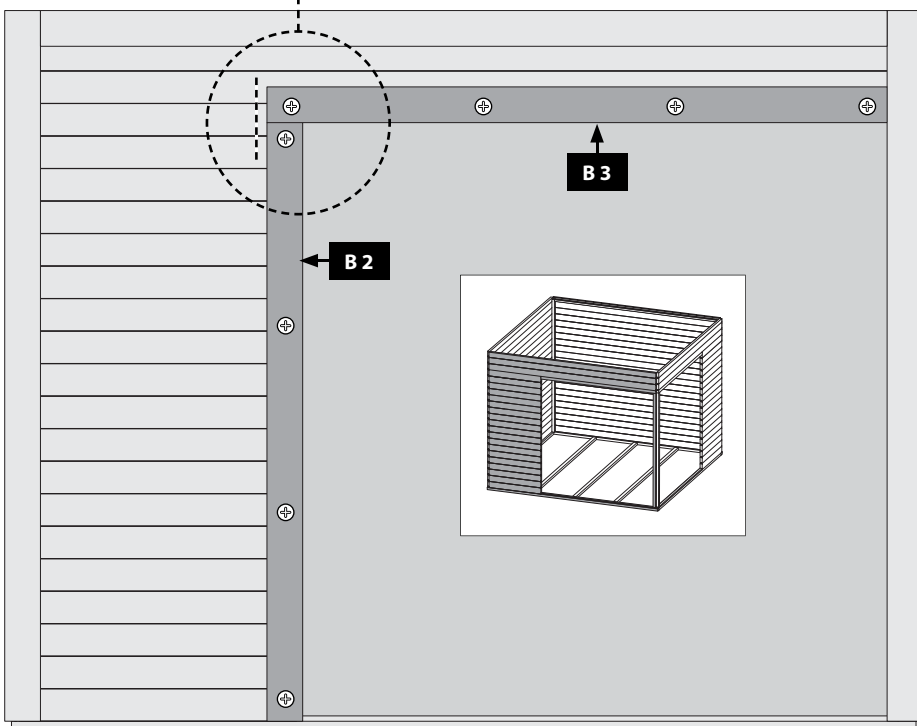
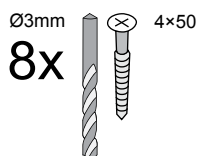

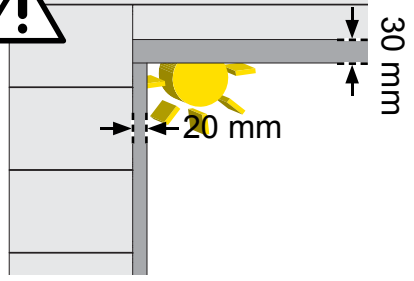

- Bündig!
- Flush!
- Affleurement!
- I flugt!
- Gelijk!
- Aras!
- Combacia!
- Stejný !

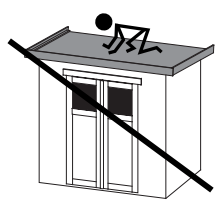
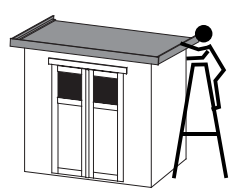
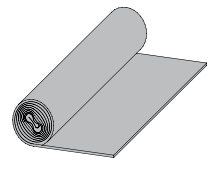
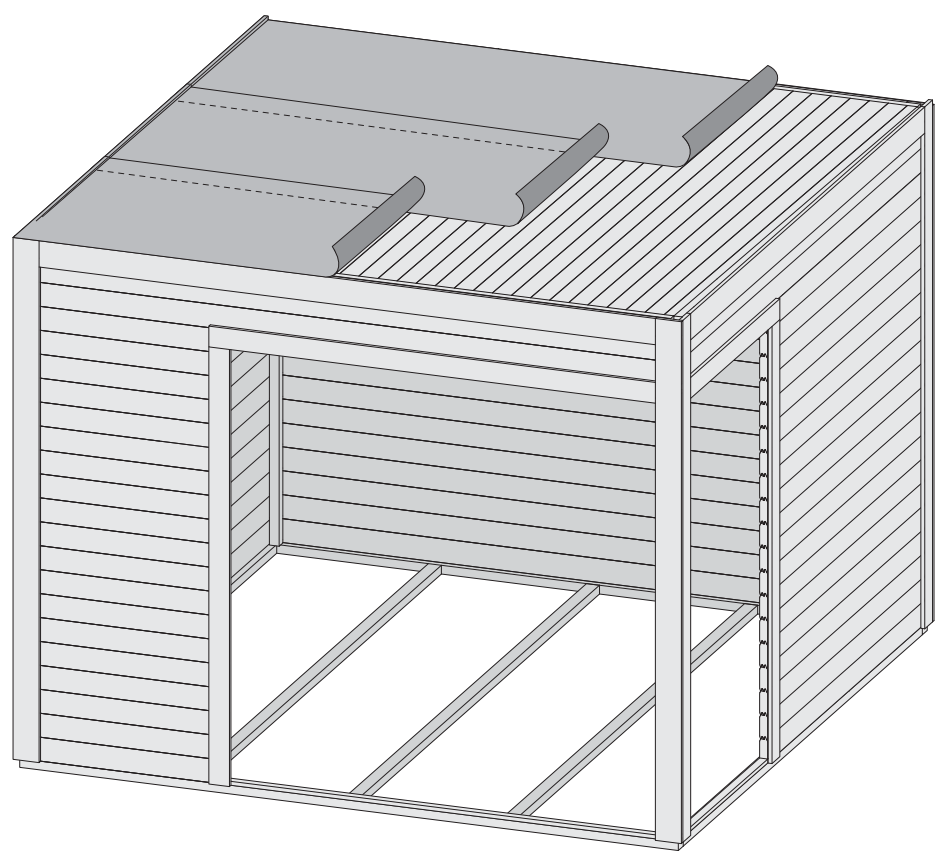
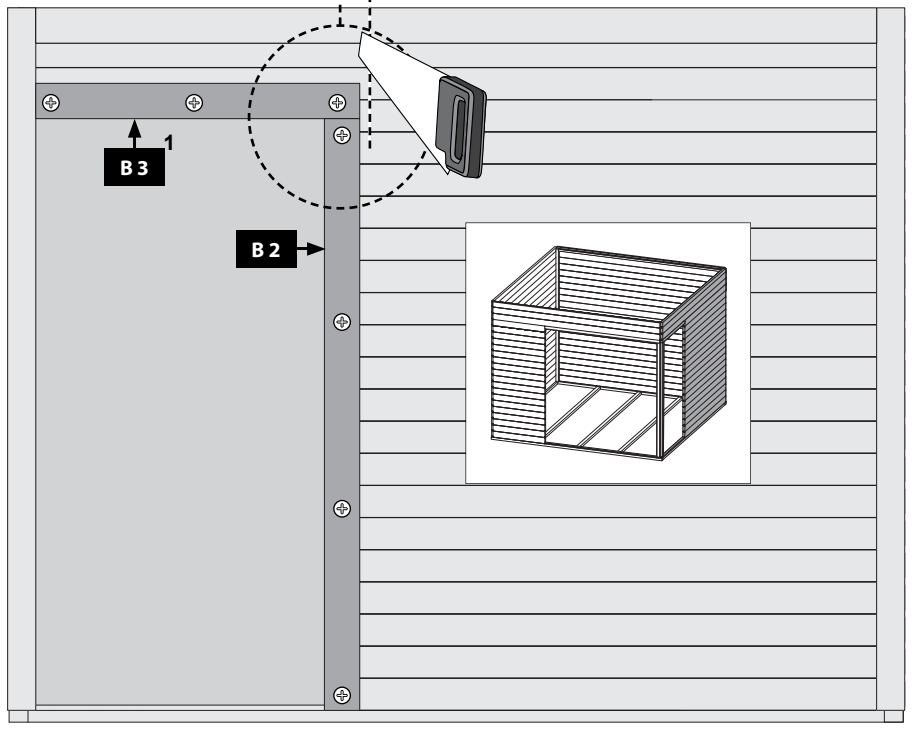
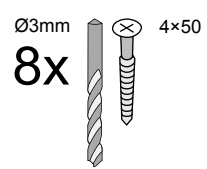

## Verlegehinweis

**Karibu Dachfolie** klebt auf Holzunterkonstruktionen, Metall, Bitumen, Beton, Mauerwerk und Kunststoffen (ausser PVC). Klebt nicht auf Silikon. Der Untergrund muss trocken, staub-, fettfrei und abriebfest sein.

Die Verarbeitungstemperatur sollte über 10 Grad Celsius betragen. Lagern Sie die Bahn bei kalten Jahreszeiten vor der Verarbeitung nicht im Freien. Eine optimale Verklebung erreichen Sie bei höheren Temperaturen. Achten Sie darauf, dass Sie Unebenheiten vor dem Aufbringen der Bahn ausgleichen.

Vor der Verlegung sollte geprüft werden, ob das Produkt für den Einsatzbereich geeignet ist.

Bei verschmutztem Untergrund muss ein bituminöser Voranstrich (lösemittelhaltig oder lösemittelfrei) aufgebracht werden.

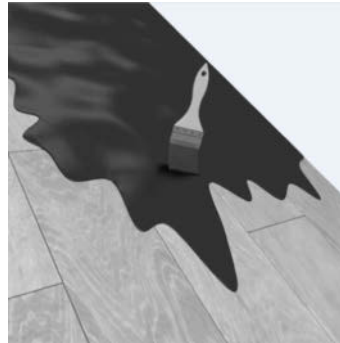

- Das Verlegen der Bahnen erfolgt längs oder quer mit einer Mindestüberlappung von 10 cm. Vor dem Abziehen der unterseitigen Folie, rollen Sie die Bahn ca. 2 m aus, um die Bahn seitlich auszurichten. Dann klappen Sie den Rollenanfang um und ziehen die Schutzfolie auf der Bahnenunterseite ca. 20 cm ab, um die Bahn so mit der Selbstklebefläche auf dem Untergrund zu fixieren (Bild 1).
- Anschließend rollen Sie die Bahn wieder zurück, bis zum verklebten/fixierten Rollenanfang.
- Rollen Sie die Bahn nun durch abziehen der unterseitigen Folie gleichmäßig aus (Bild 2) und achten Sie darauf, dass es keine Lufteinschlüsse gibt. Lufteinschlüsse sind gleichmäßig nach außen weg zu bürsten.
- Achten Sie besonders im Überdeckungsbereich darauf, dass eine gute Verklebung eintritt. Sie können die beste Klebewirkung mit einer Anpresswalze erreichen (Bild 3).

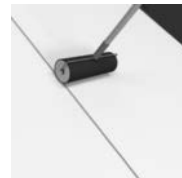
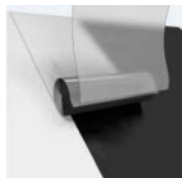
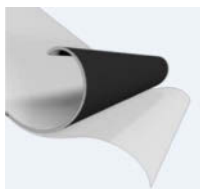

# Karibu Dachfolie 5 x 1m

Edition: 18/02/2016

## EINSATZBEREICH / Produkt

*Kaltselbstklebende, oberseitig alukaschierte Dachbahn, zur Dacheindeckung von untergeordneten Dächern, wie z. B. von Carports, Gartenhäusern, Geräteschuppen, usw.*

## ZUSAMMENSETZUNG

*Oberseitige Deckschicht  
und Träger:*

*UV – beständiger Aluminiumverbund*

*Unterseitige Deckschicht:*

*Thermoplastischer Bitumenklebstoff mit silikonisierter Abziehfolie*

## BESCHICHTUNG

*Oberseite:*

*UV- beständiger Aluminiumverbund*

*Unterseite:*

*silikonisierte Folie*

## ABMESSUNGEN

*Länge:*

*5 ( $\pm 1\%$ ) x 1 ( $\pm 1\%$ ) m*

*Dicke:*

*1,1 mm ( $\pm 5\%$ )*

*Gewicht / Dachbahn:*

*$\pm 6$  kg*

## VERPACKUNG

*Rollen / Palette:*

*54 (270 m<sup>2</sup>),*





*jede Rolle einzeln in Kartonverpackung, mit Aufdruck der Produktbezeichnung, -erklärung und Verlegehinweisen*



## TECHNISCHE INFO

	<i>Höchstzugkraft</i>		<i>Wärmestand-</i>
	<i>Länge</i>	<i>Breite</i>	<i>festigkeit bei 80°C</i>
<i>Minimalwerte</i>	$\geq 200N$	$\geq 200N$	$< 2mm$
	<i>Wasserdampf-</i>		<i>Brandklasse</i>
	<i>Durchlässigkeit sd</i>		
<i>Minimalwerte</i>	$> 1500 m$		<i>E</i>





-  Breite Seite nach oben
-  Width side up
-  Largeur vers le haut
-  Breedte side up

-  Ancho de banda de hasta
-  Larghezza verso l'alto
-  Šířka stranou nahoru

~335x

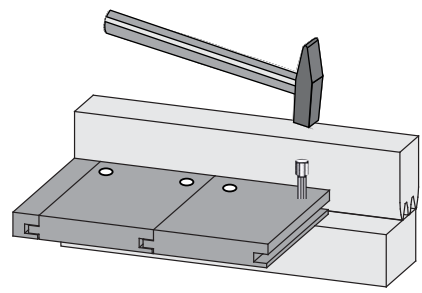
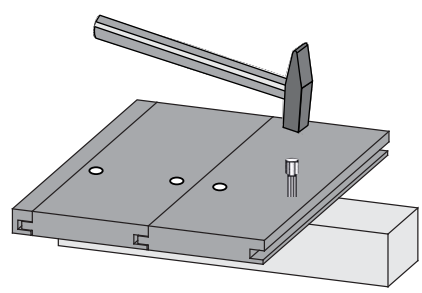
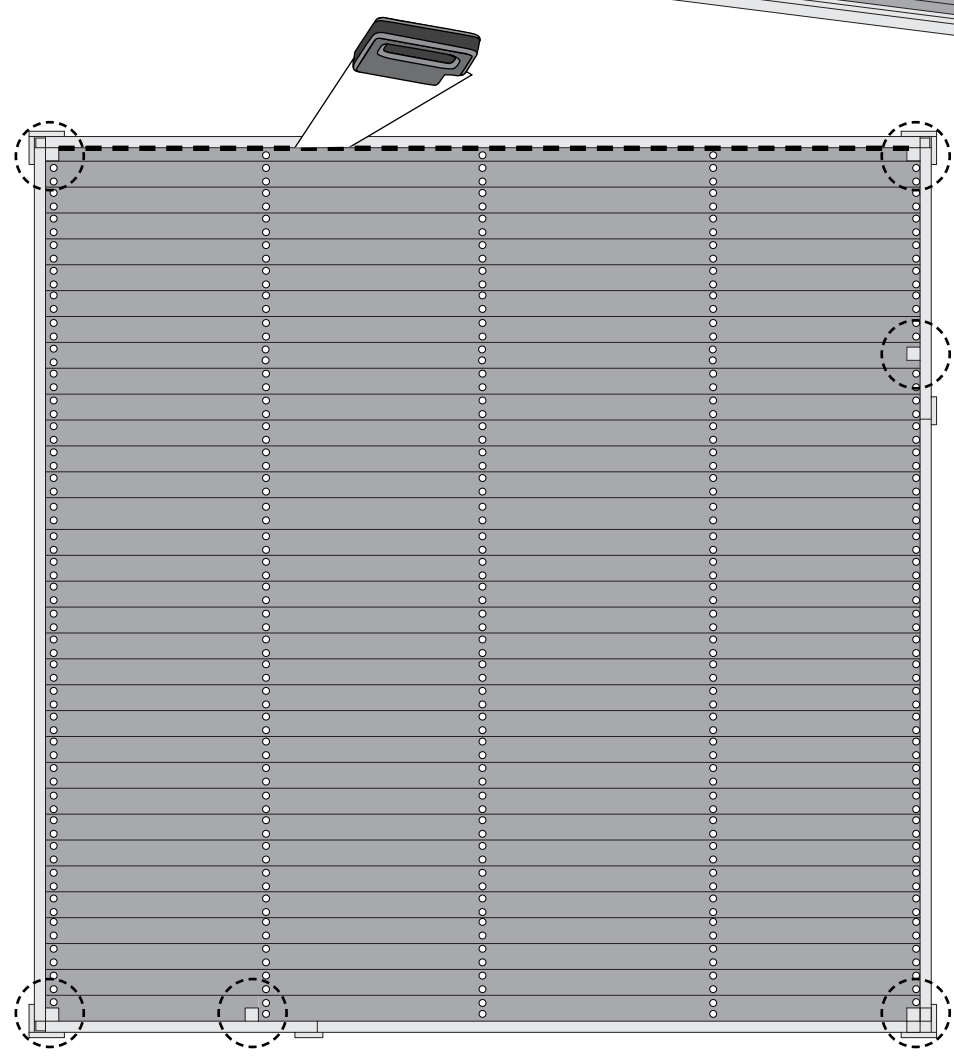
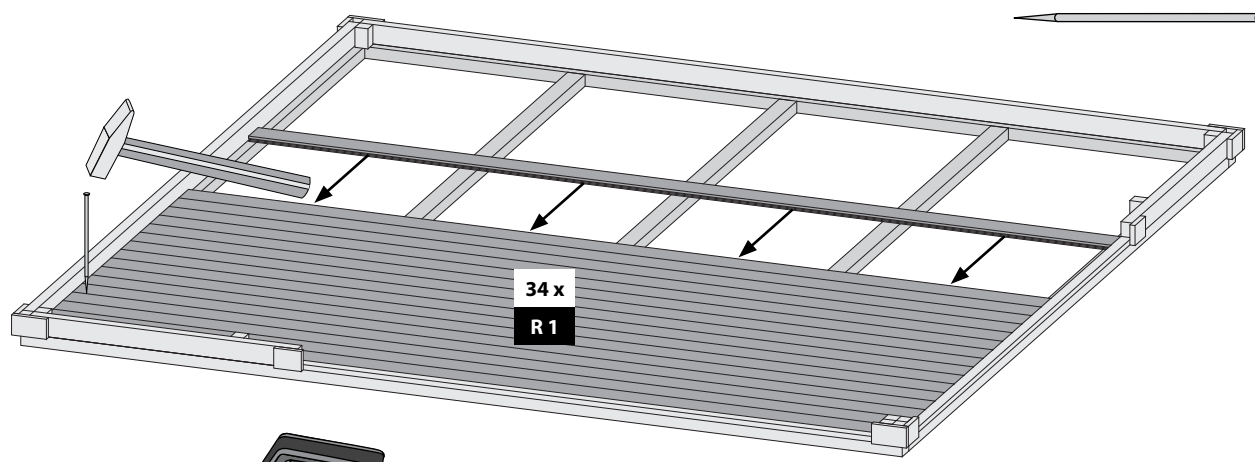

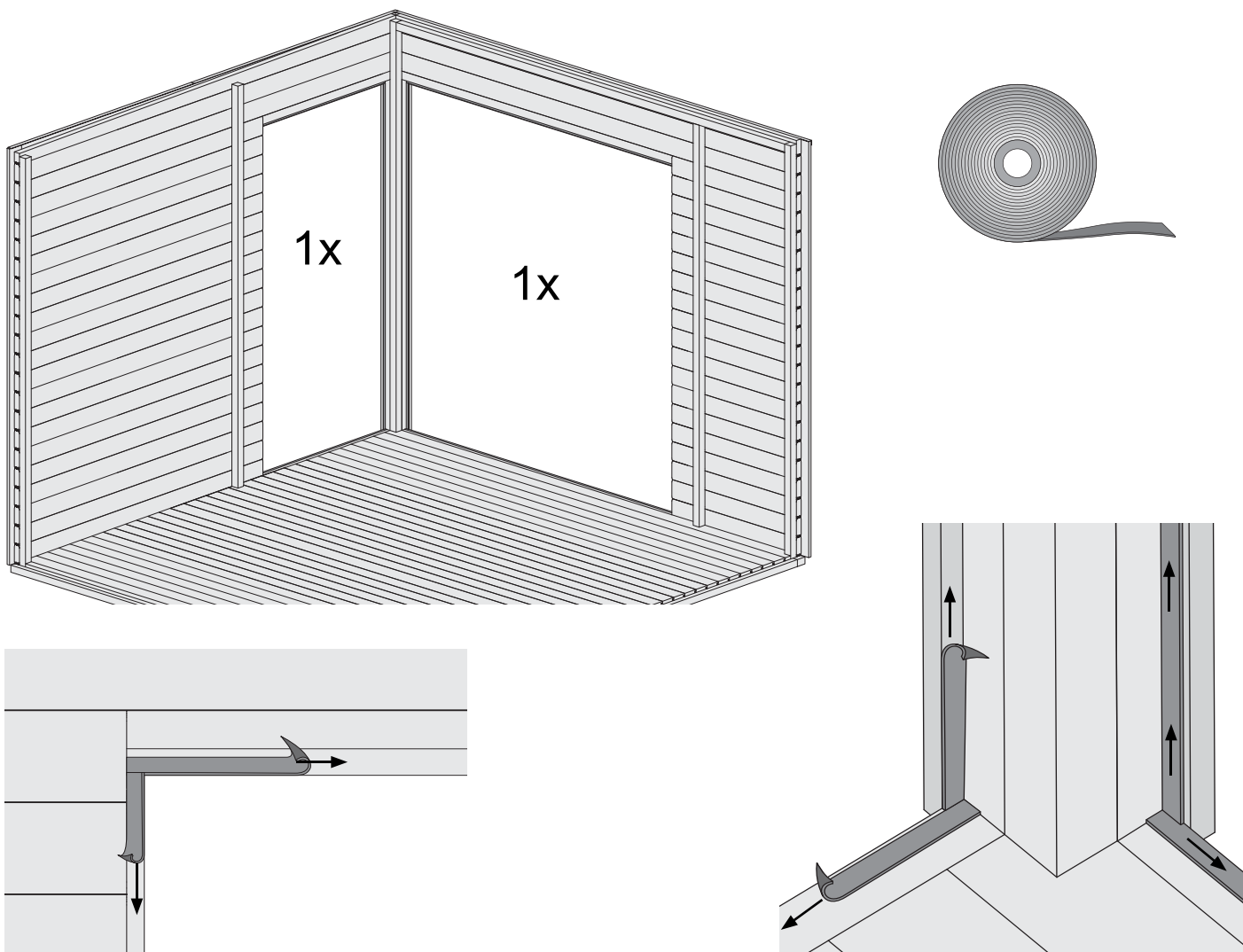
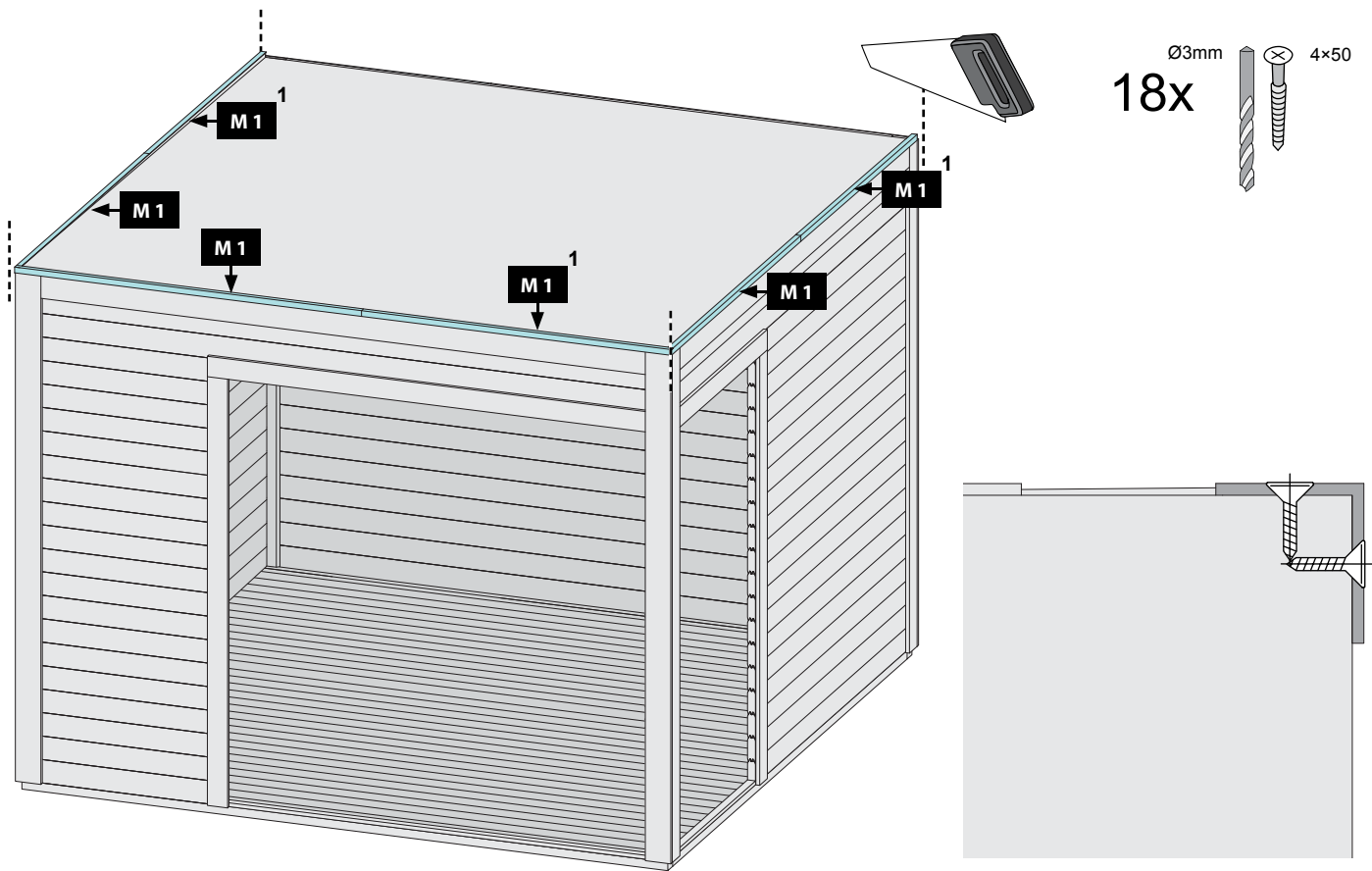

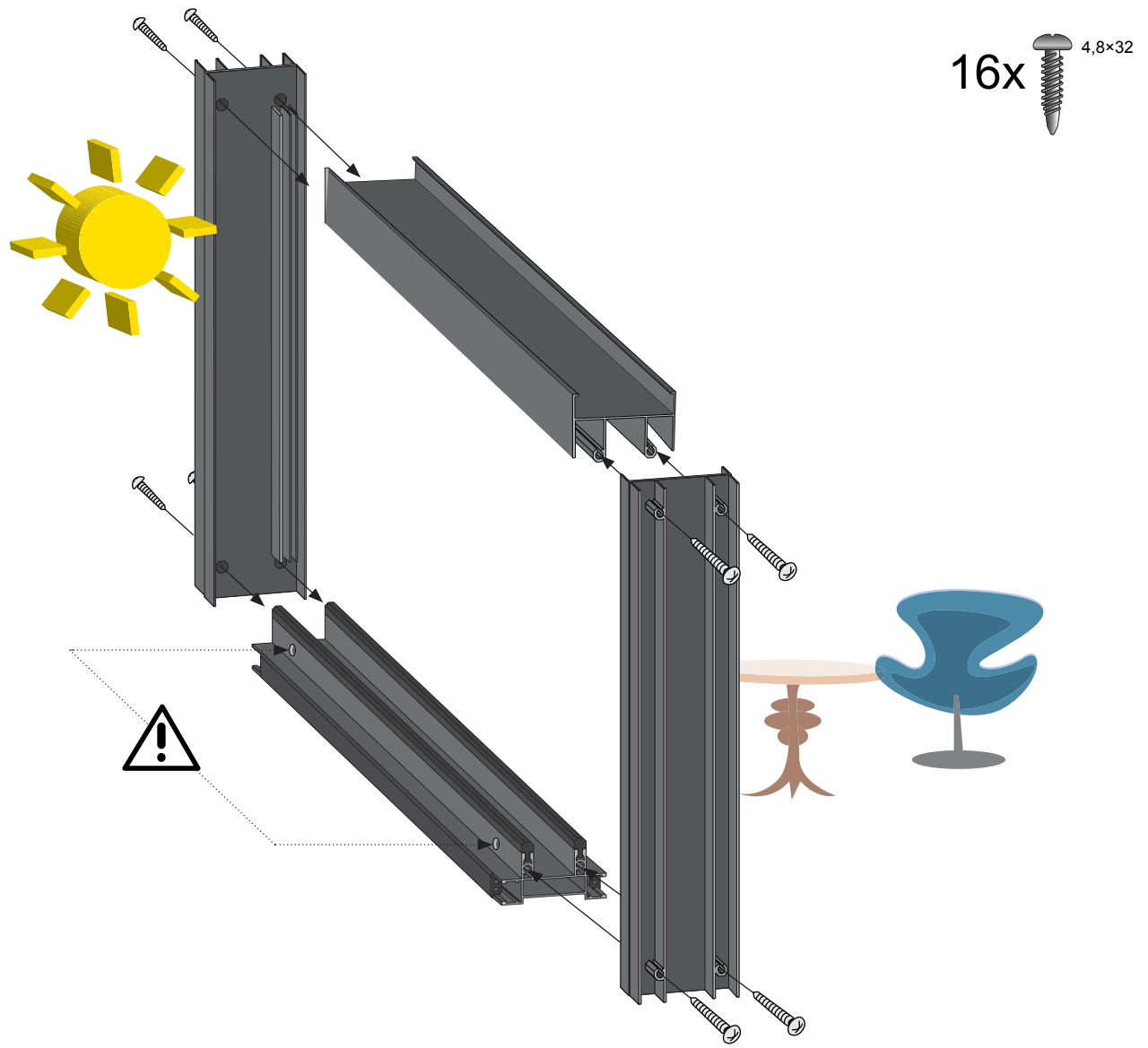
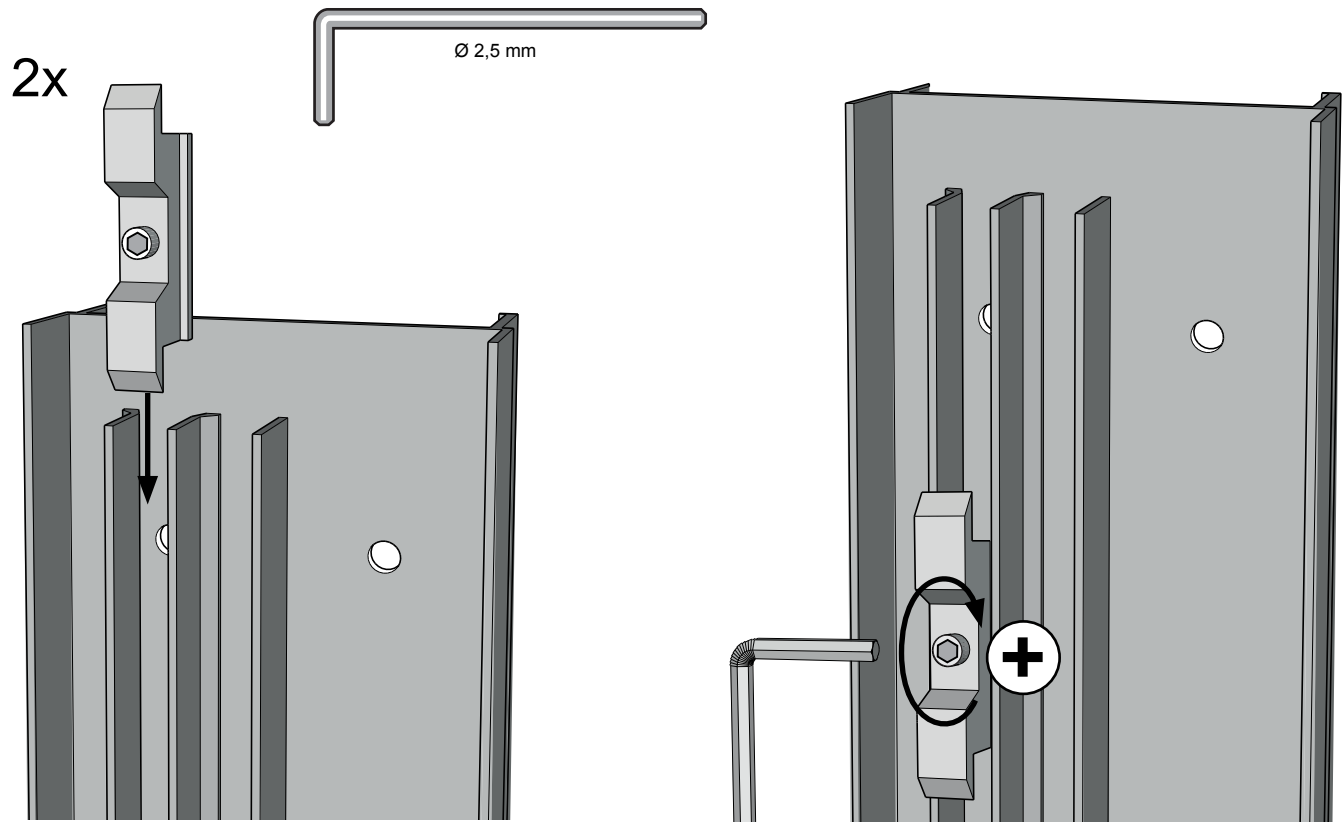

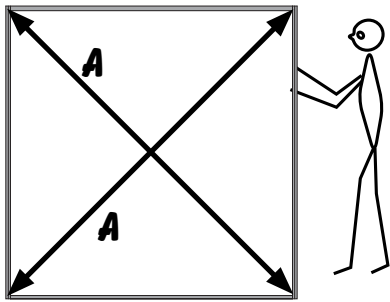
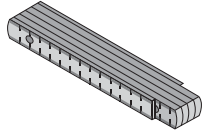
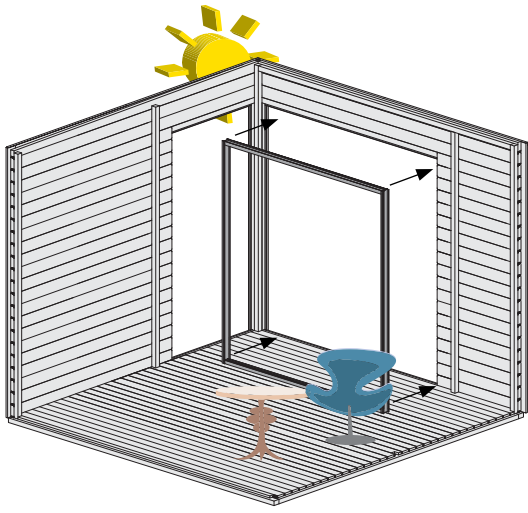

**A=A**

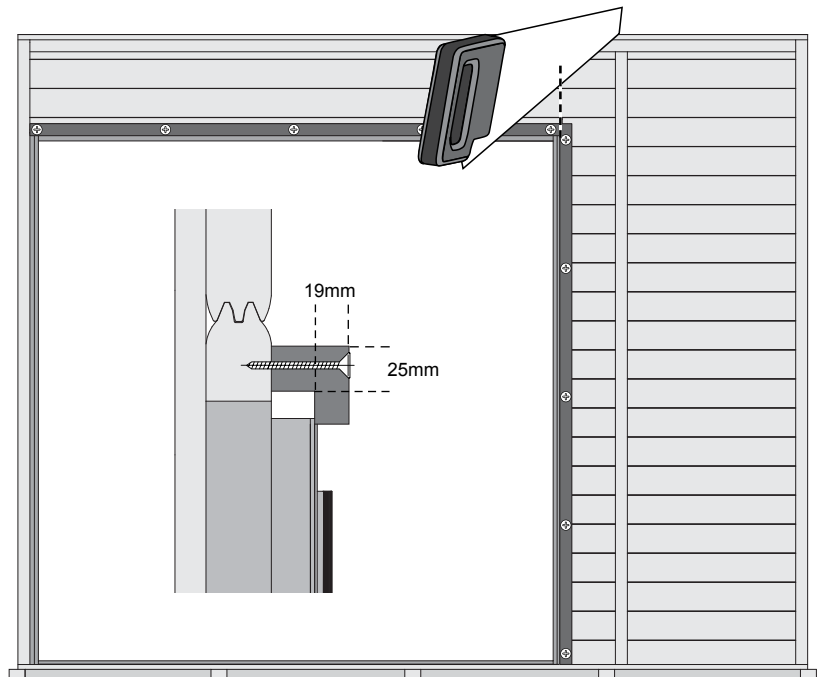
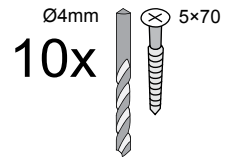
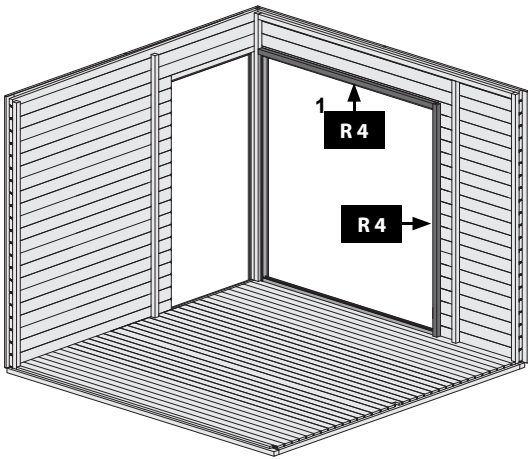
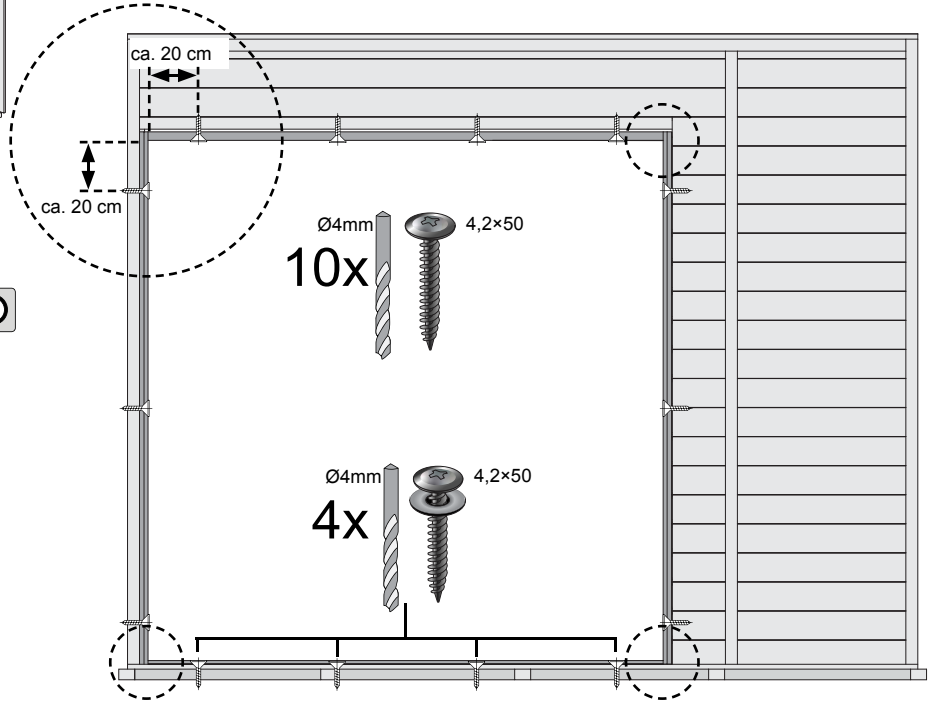

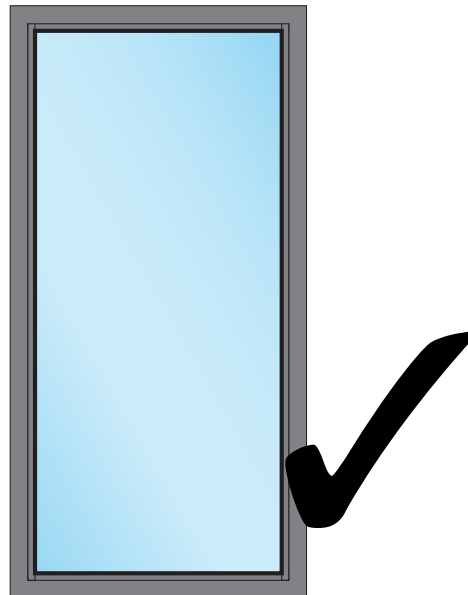
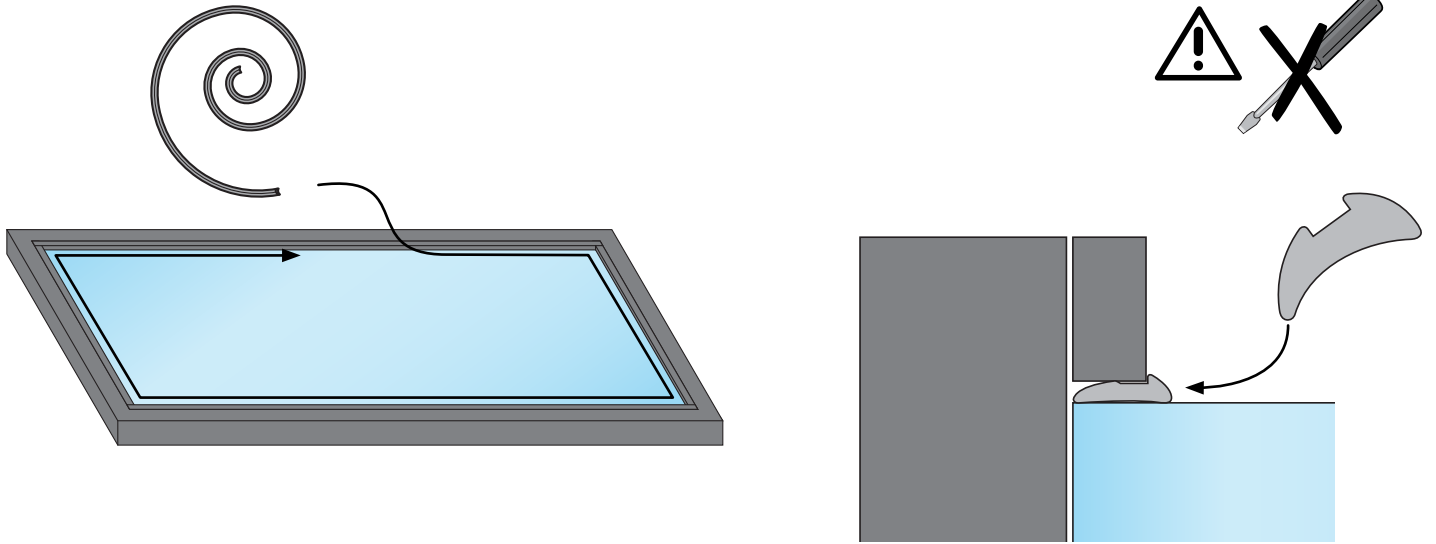
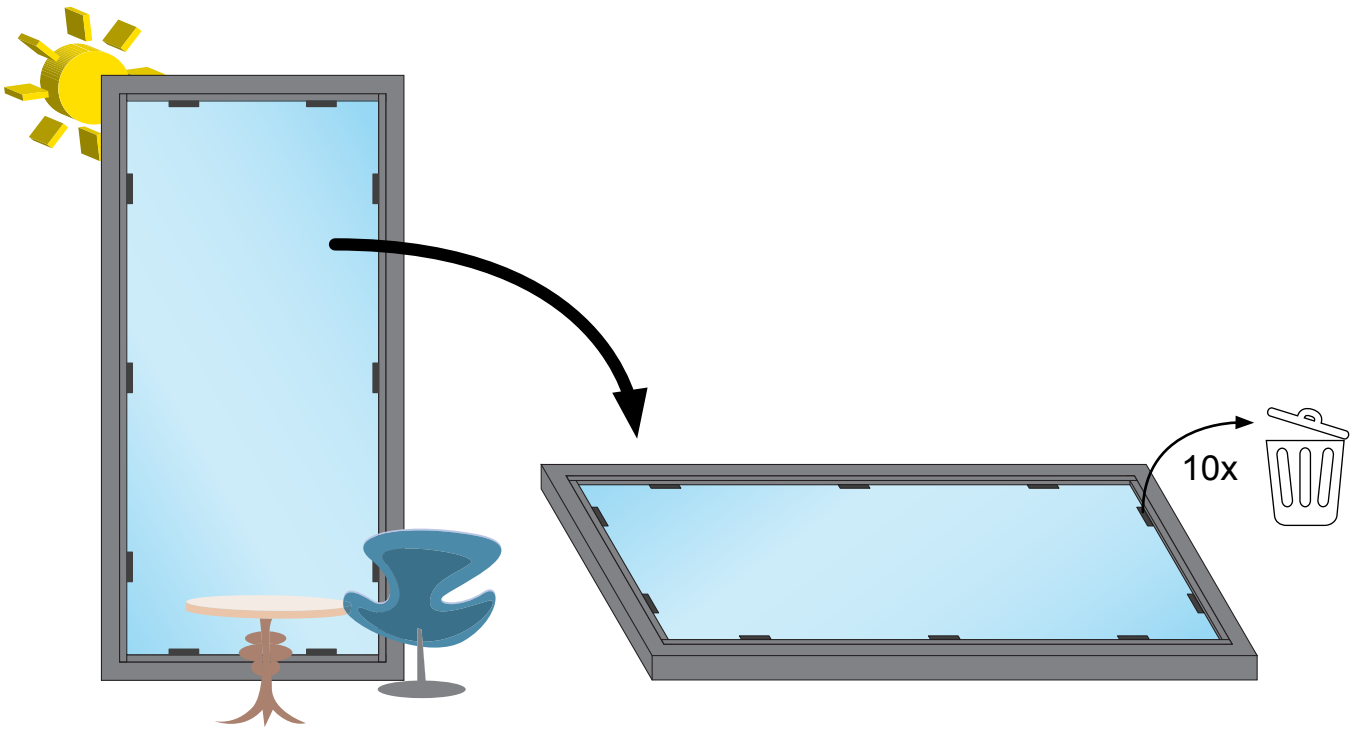

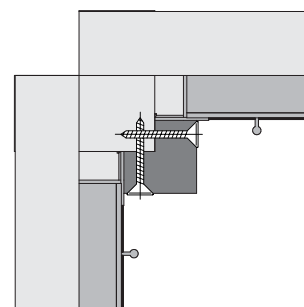
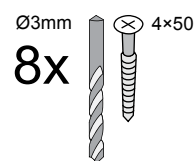
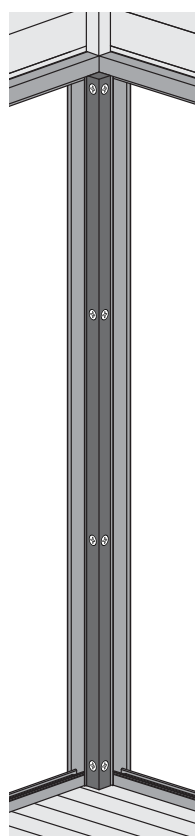
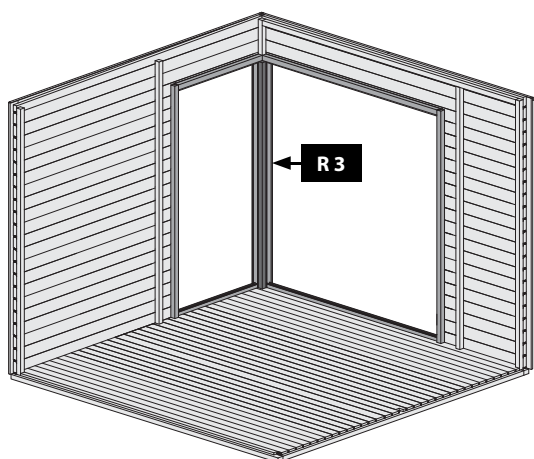
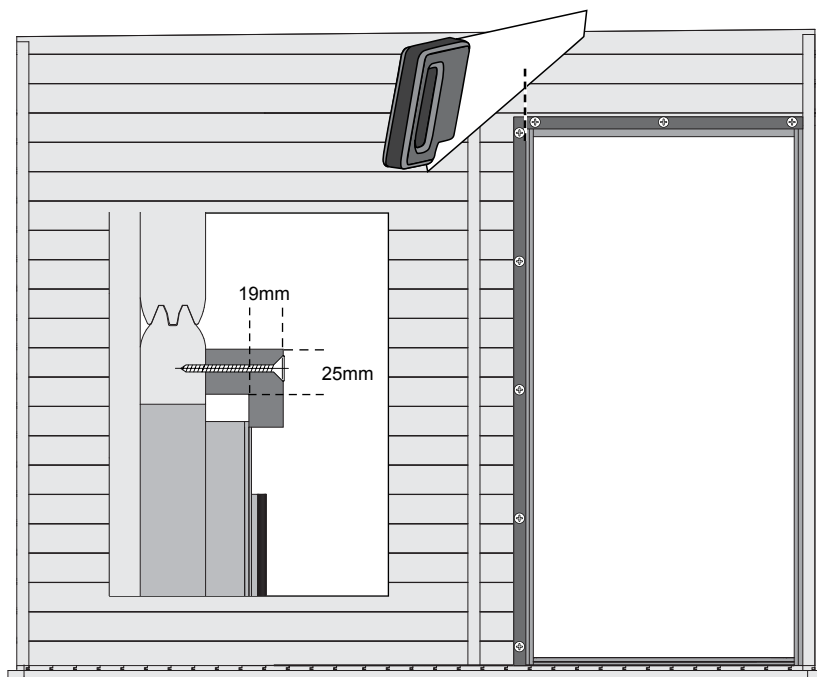
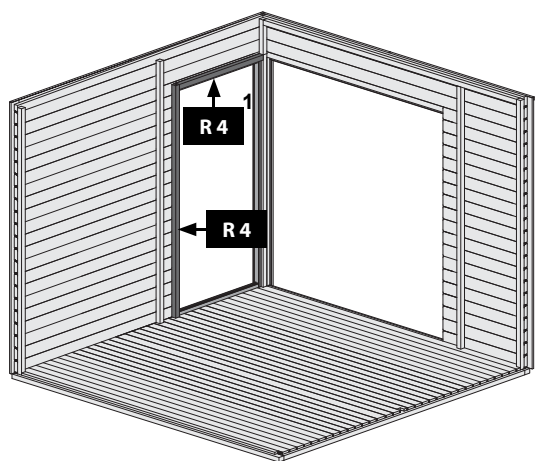
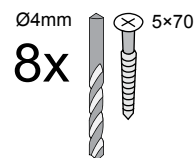
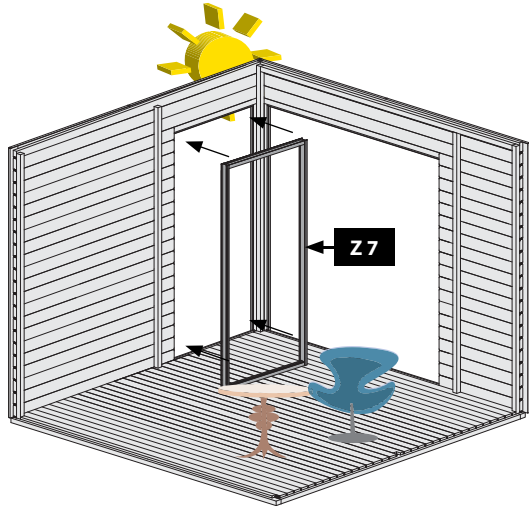

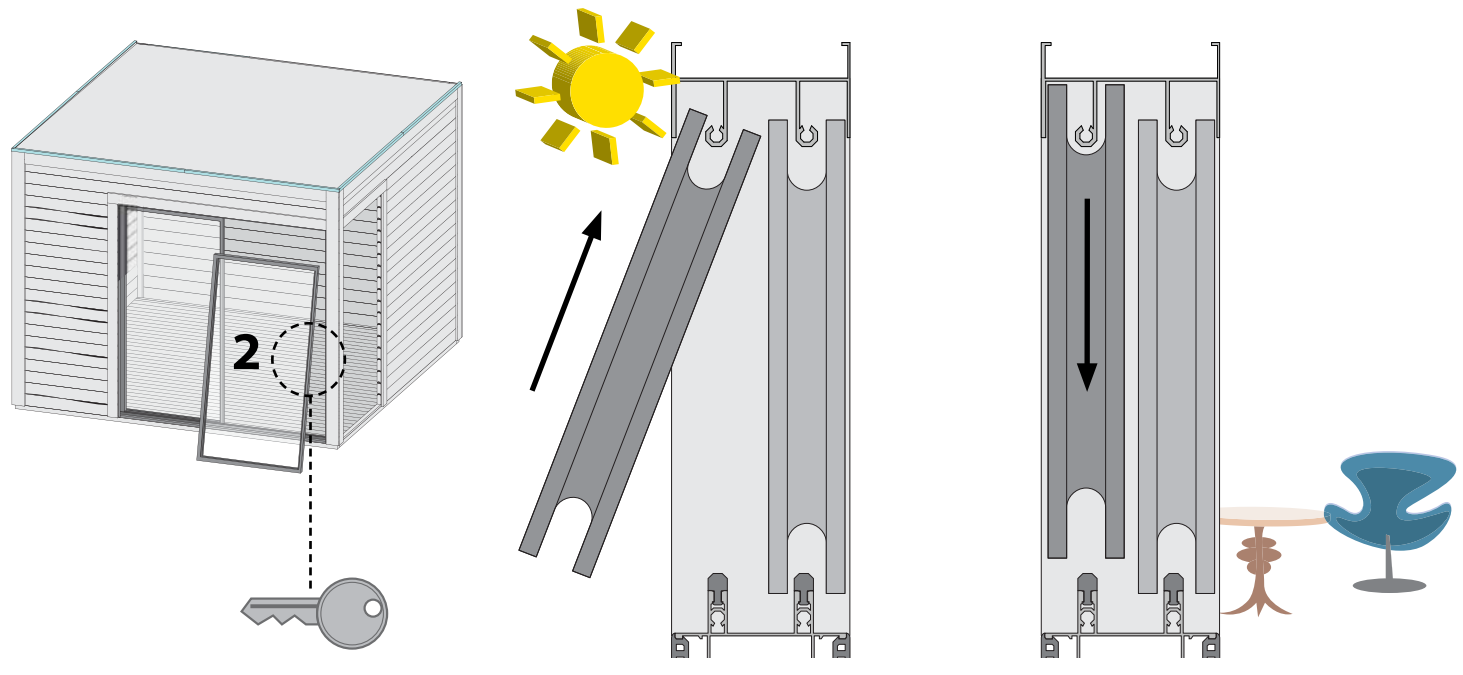
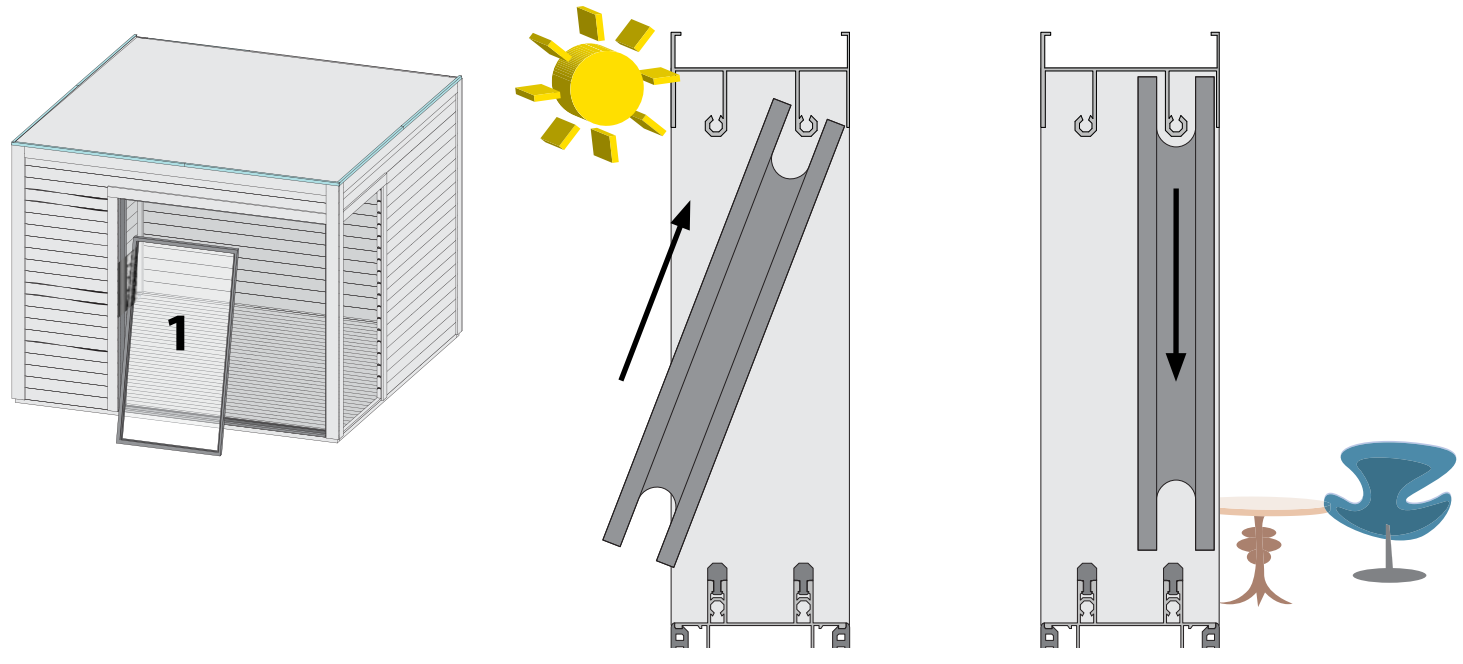
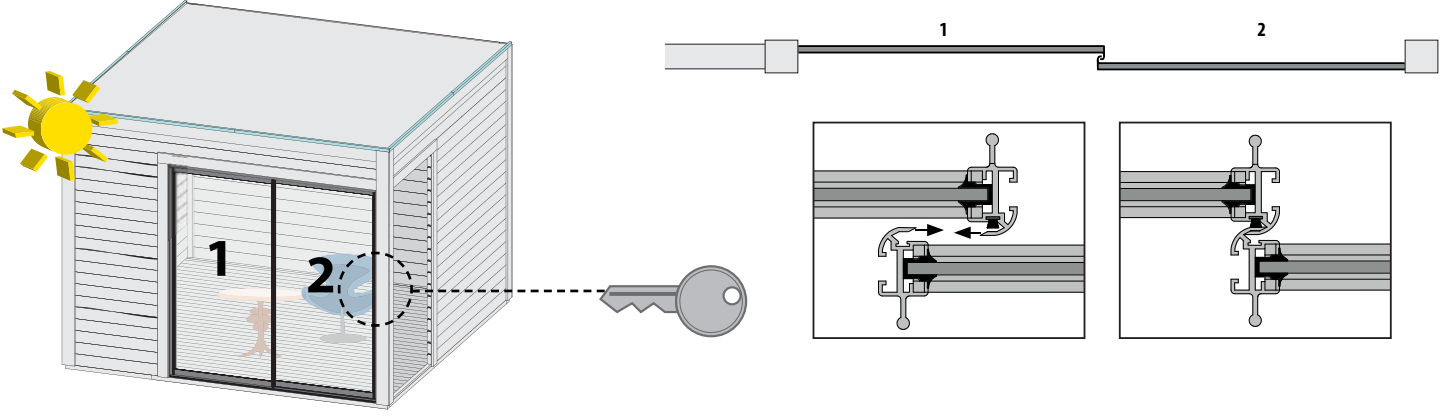

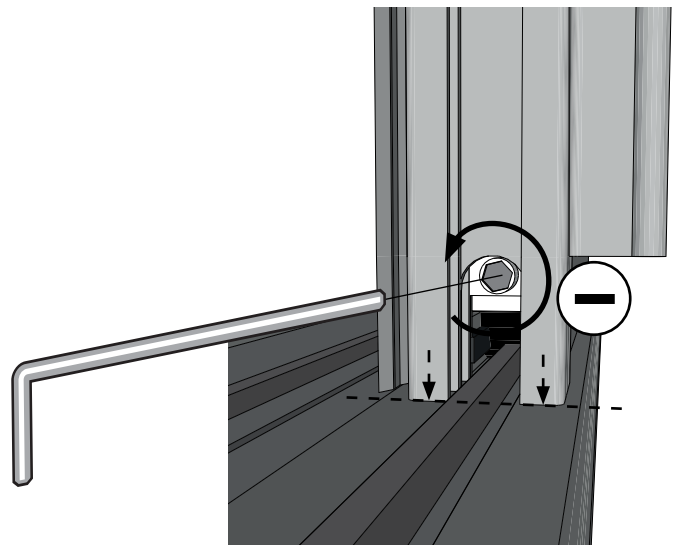
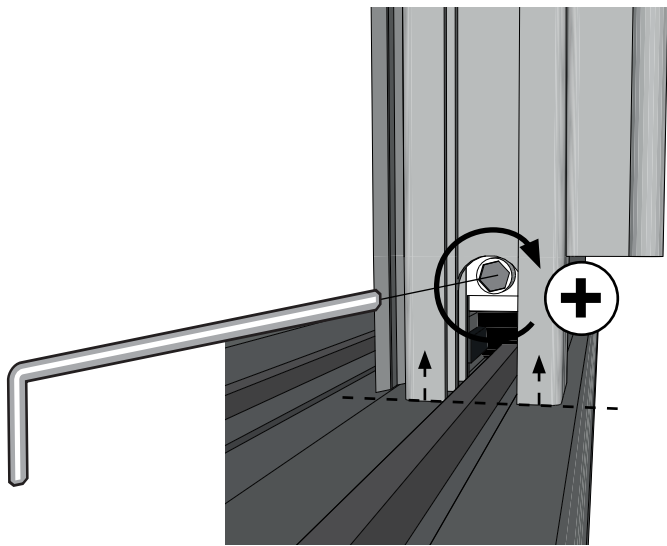
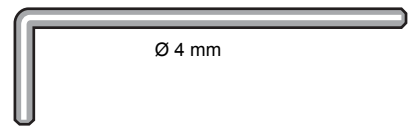
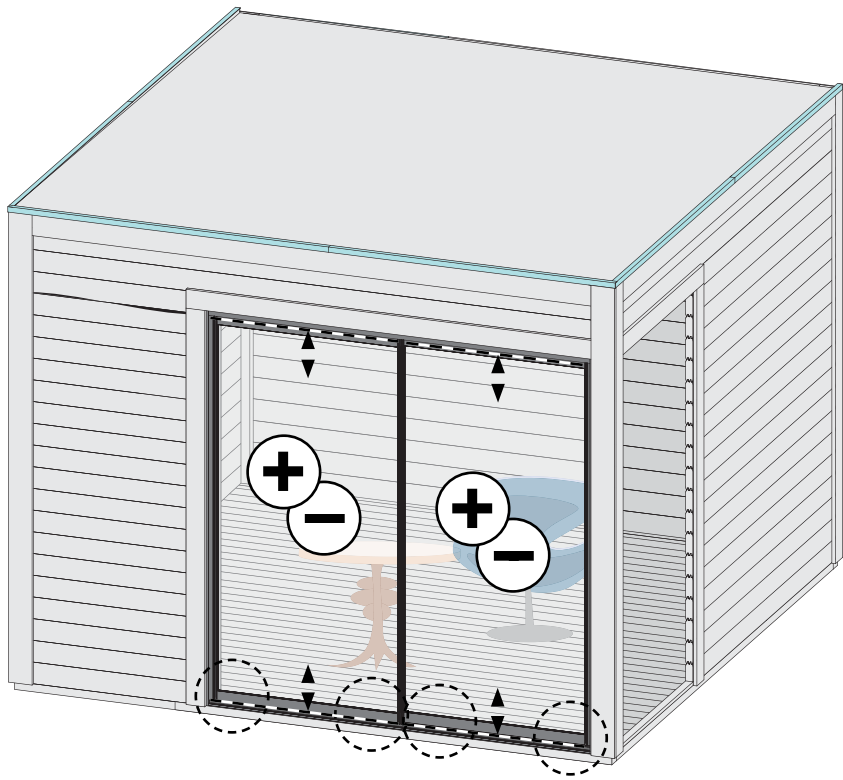



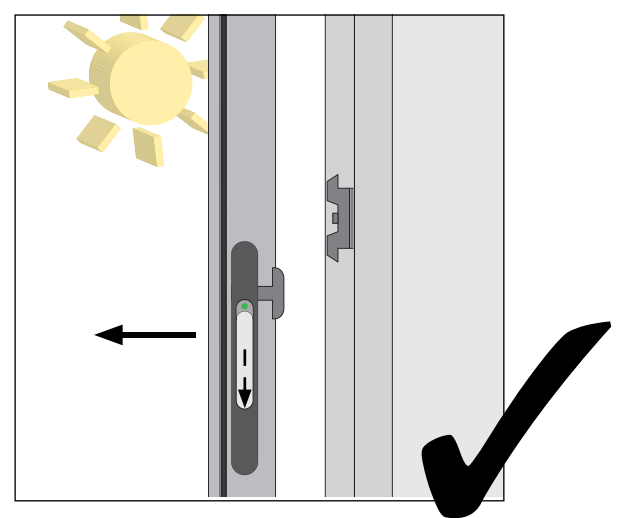
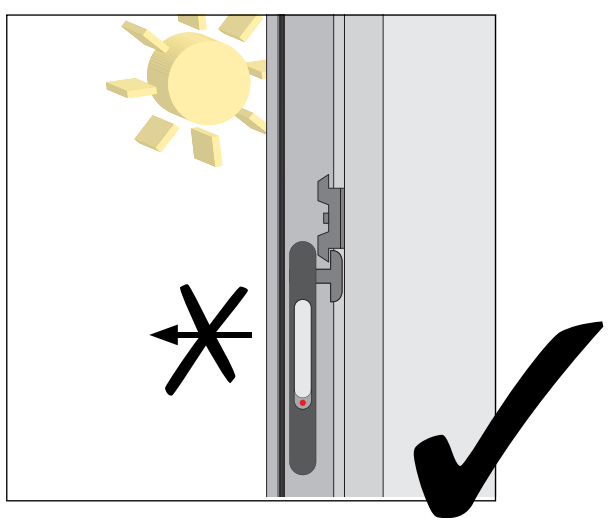
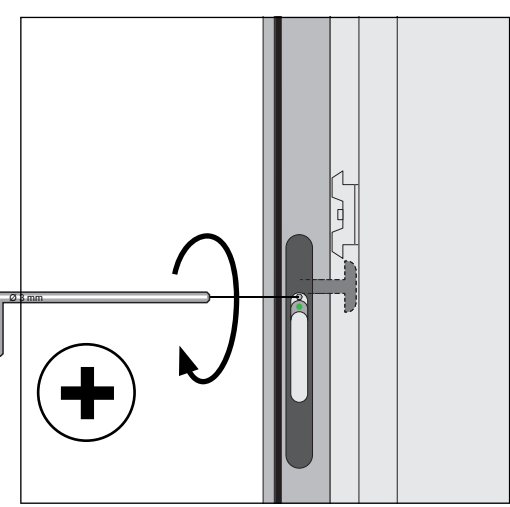
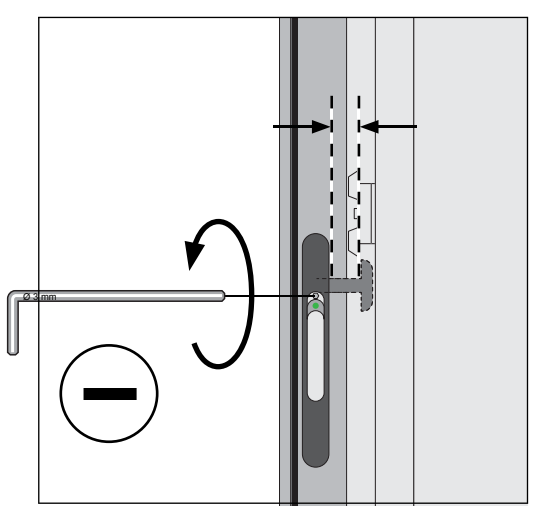
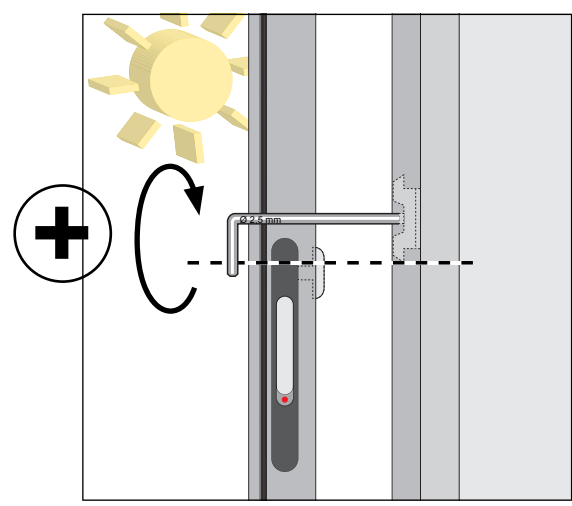
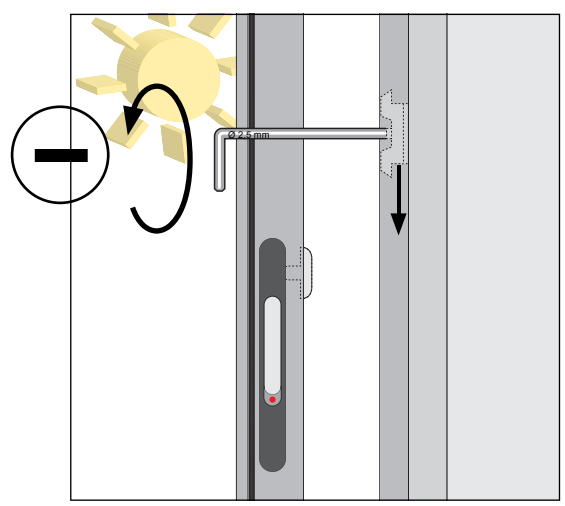
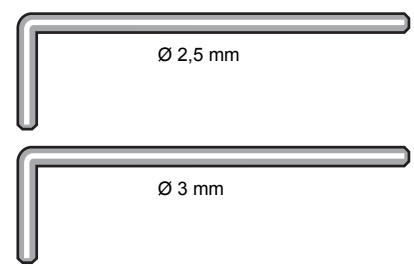
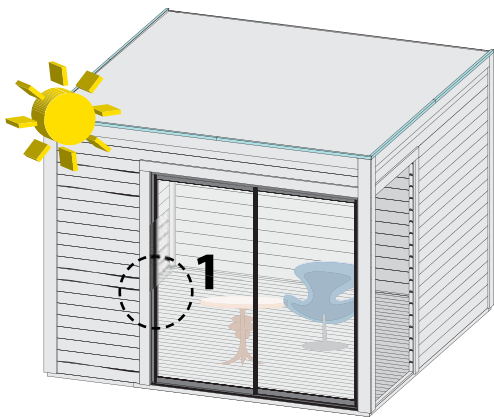

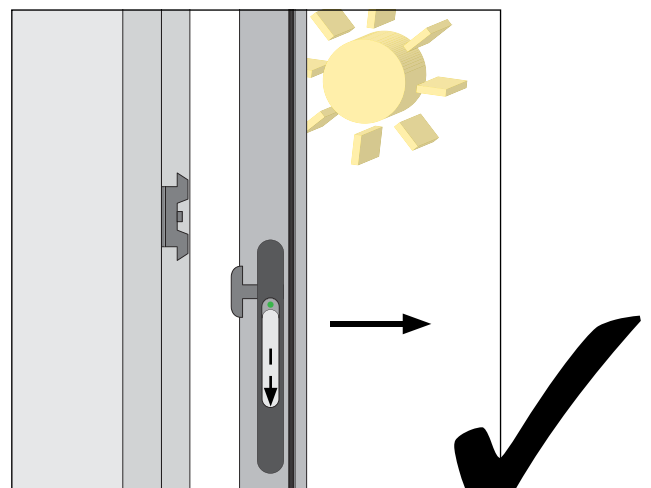
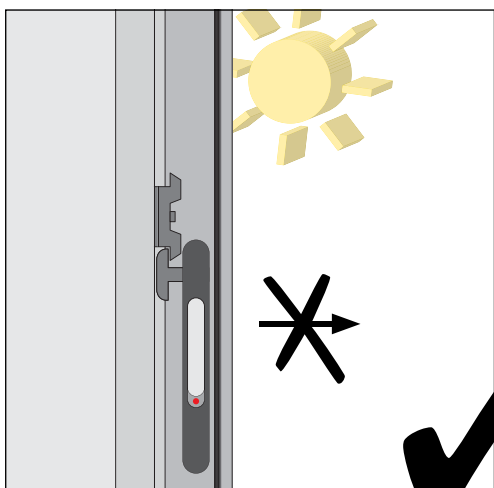
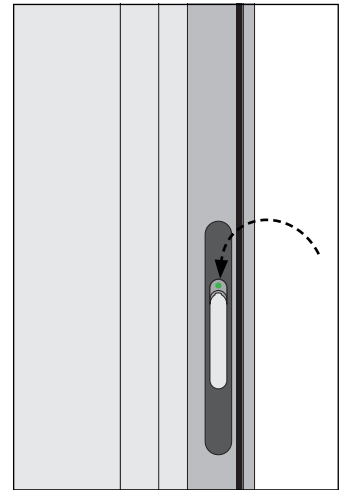
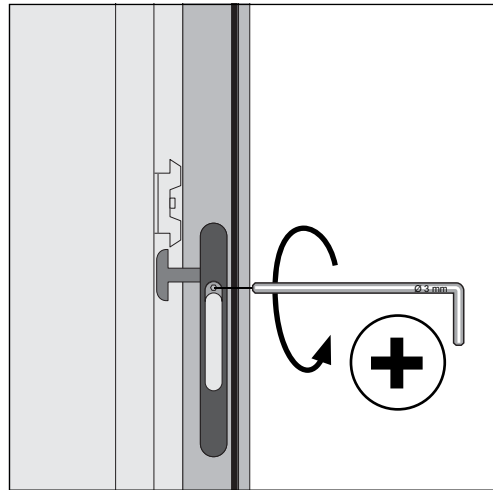
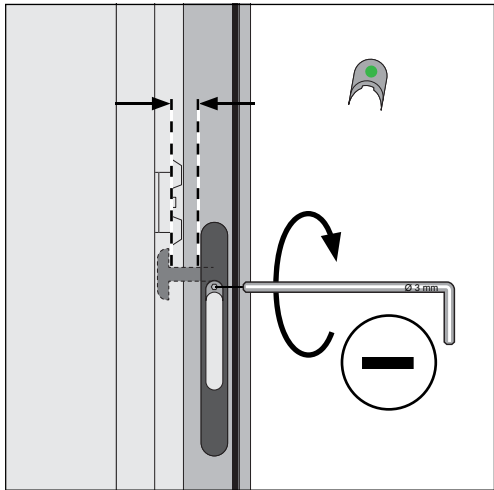
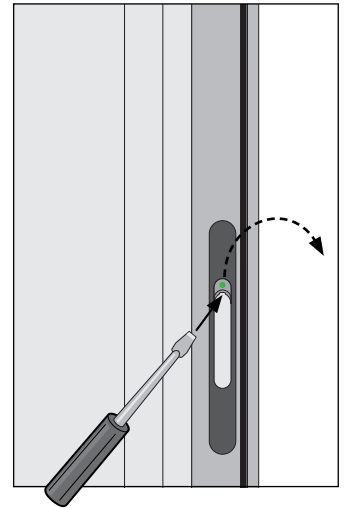
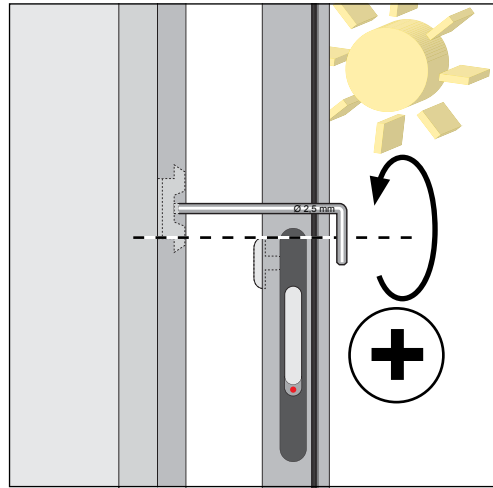
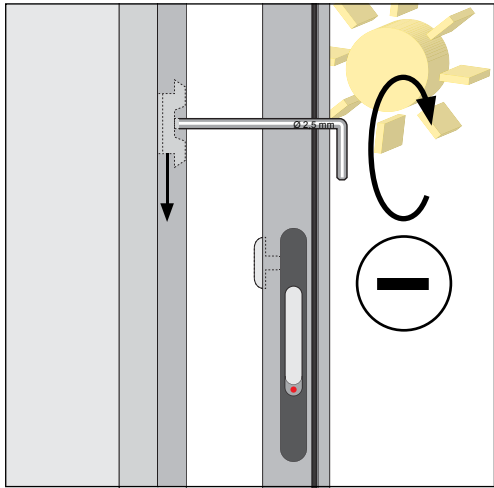
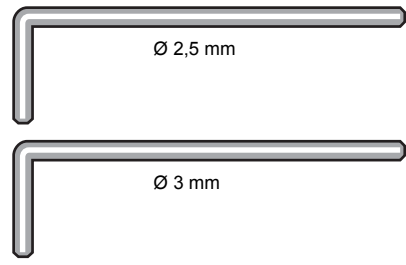
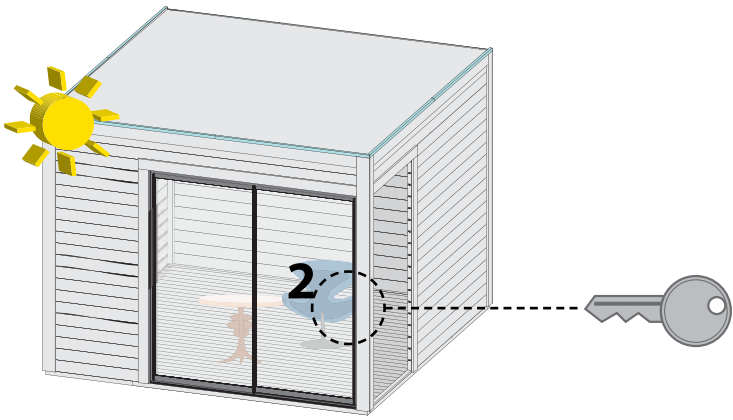

# 34392

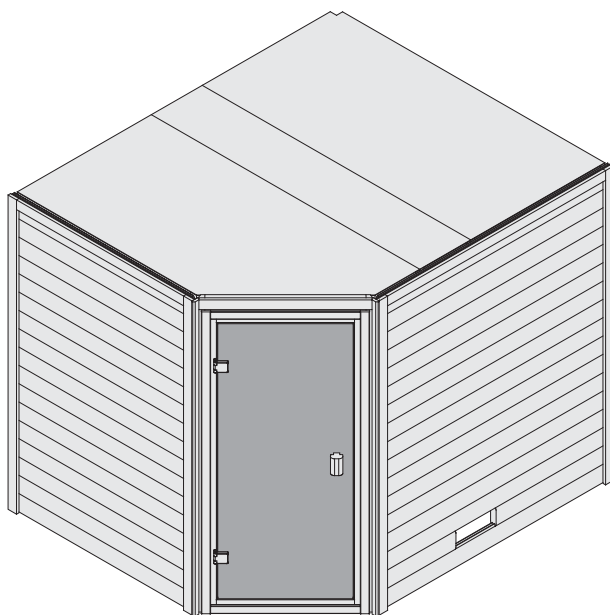

-  **Aufbauanleitung**
-  **Building Instructions**
-  **notice de montage**
-  **montagehandleiding**
-  **Montagevejledning**
-  **Instrucciones de construcción**
-  **Istruzioni per il montaggio**
-  **Montážní návod**

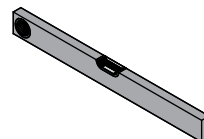
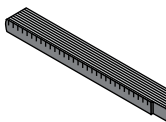
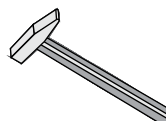
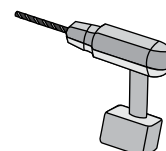
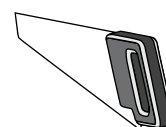





Bitte bewahren Sie die Anleitung und den Garantieschein zur Seriennummer auf.





Vernichten Sie diese erst nach Ablauf der Garantiezeit.





Eventuelle Beanstandungen können mithilfe der Stückliste einfacher zugeordnet werden.





#### Beigelegte Dokumente

- Informationsheft
- Garantieschein zur Seriennummer
- Typenschild inkl. Warnhinweise (Sauna)
- ggf. Zubehör-Anleitungen in externen Paketen





- \*  Nicht im Lieferumfang enthalten  
 Not included  
 Non comprises dans la livraison  
 Niet bijgeleverd

-  No forman parte del suministro  
 Non incluso  
 V ceně není zahrnuto  
 Ikke inkluderet

- 1  Länge muss ermittelt und zugesägt werden  
 Length must be determined and sawn  
 La longueur doit être déterminée et sciée  
 De lengte moet worden bepaald en worden gezaagd

-  La longitud debe ser determinada y aserrada  
 La lunghezza deve essere determinata e segata  
 Délka musí být určena a rozřezána  
 Længden skal bestemmes og saves





- 2  Nicht gebraucht  
 Not needed  
 Pas nécessaire  
 Niet nodig

-  No es necesario  
 Non necessario  
 Není nutná  
 Ikke nødvendigt





- 3  Mit Zubehör  
 With accessories  
 Avec accessoires  
 Met toebehoren

-  Con accesorios  
 Con accessori  
 S příslušenstvím  
 Med tilbehør

- 4  Fixiert vorübergehend  
 Fixed temporarily  
 Temporairement fixe  
 Tijdelijk vast

-  Temporalmente fijo  
 Temporaneamente fisso  
 Dočasně pevný  
 Midlertidigt rettet

- 5  Bestand vom Haus  
 Inventory of the house  
 Inventaire de la maison  
 Inventaris van het huis

-  Inventario de la casa  
 Inventario della casa  
 Inventář domu  
 Inventar af huset

Werkzeuge / Tools\*

X

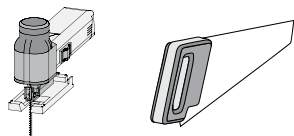

X

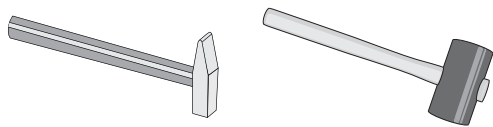

X

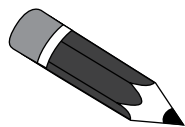

X

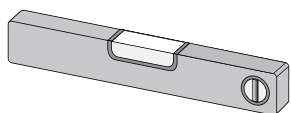

X

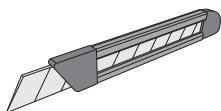

X

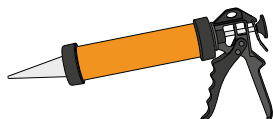
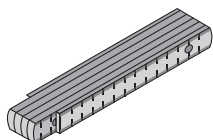

X

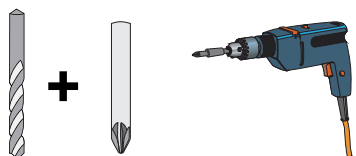

X

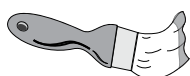
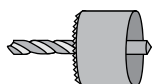
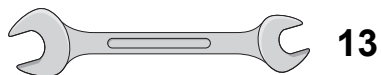

X



Technische Daten

In der Auftragsbestätigung bzw. Lieferschein ist der gekaufte Ofentyp bzw. das erworbene Steuergerät zu finden. Bitte entnehmen Sie die technischen Daten Ihrer Geräte der folgenden Auflistung

Gerät	Netzspannung	Wattage
Öfen		
9kW Ofen Bio	400V ~ 3N	9kW
9kW Ofen (Finnisch)	400V ~ 3N	9kW
9kW Ofen integr. Steuerung	400V ~ 3N	9kW
4,5kW Ofen Bio	400V ~ 3N	4,5kW
4,5kW Ofen (Finnisch)	400V ~ 3N	4,5kW
4,5kW Ofen integr. Steuerung	400V ~ 3N	4,5kW
3,6kW Ofen Bio	230V ~ 1N	3,6kW
3,6kW Ofen (Finnisch)	230V ~ 1N	3,6kW
3,6kW Ofen integr. Steuerung	230V ~ 1N	3,6kW
Steuergeräte		
externe Steuerung Easy Bio	400V ~ 3N	max. 10,8kW
externe Steuerung Plug&Play Bio	240V ~ 3N	max. 10,8kW
externe Steuerung (Finnisch)	400V ~ 3N	max. 10,8kW
externe Steuerung Plug&Play (Finnisch)	240V ~ 3N	max. 10,8kW
Multisteuergerät	400V ~ 3N	max. 10,5kW
externe Steuerung Classic Bio	400V ~ 3N	max. 9kW
externe Steuerung Classic (Finnisch)	400V ~ 3N	max. 9kW
externe Steuerung Premium Bio	400V ~ 3N	max. 12kW
externe Steuerung Premium (Finnisch)	400V ~ 3N	max. 9kW



Vergleichen Sie zuerst die Material-liste mit Ihrem Paketinhalt! Bitte haben Sie Verständnis, dass Beanstandungen nur im nicht aufgebauten Zustand bearbeitet werden können!



Vergelijk eerst de lijst van materialen met de inhoud van uw pakket! Reclamaties kunnen alleen in behandeling worden genomen zolang de onderdelen nog niet zijn gemonteerd!



Confrontate questa distinta materiali prima con il contenuto del pacchetto! Vi preghiamo di comprendere che eventuali reclami possono essere accolti solo prima del montaggio!



First compare the list of materials with your package contents! Please understand that complaints can be processed in the non-built status only!



Start med at kontrollere materialelisten med indholdet af den leverede pakke! Vi gør venligst opmærksom på at reklamationer kun kan behandles for materialer som ikke er blevet bearbejdet!



Nejprve přezkontrolujte obsah balení podle materiálového listu! Mějte pochopení pro to, že případnou reklamaci se můžeme zabývat pouze tehdy, když díly nebudou smontované! Za pomoci tohoto seznamu můžete jednotlivé díly přiřadit k montážnímu návodu.



Commencez par comparer la liste du matériel avec le contenu de votre paquet! Sachez que nous traitons uniquement les réclamations concernant le matériel à l'état non monté!



En primer lugar, compare la lista de material con el contenido del paquete. Rogamos entienda que las reclamaciones sólo pueden ser tramitadas antes de montar el objeto!

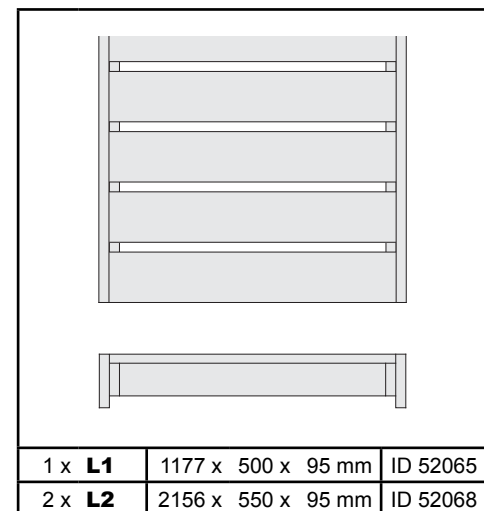
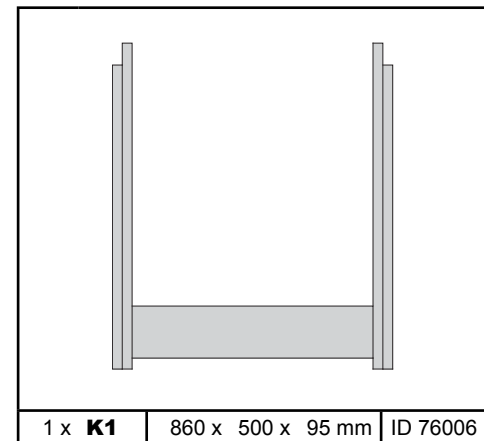
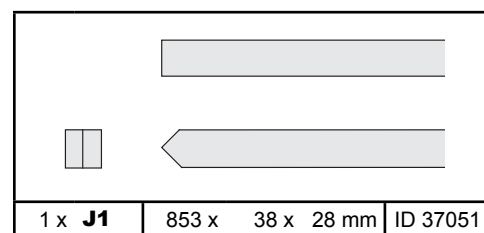
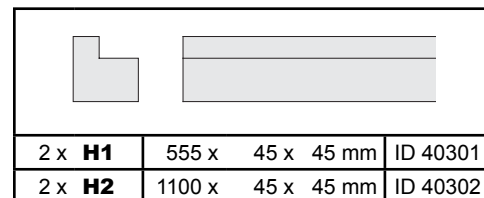
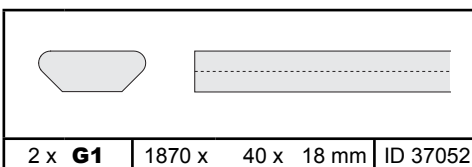
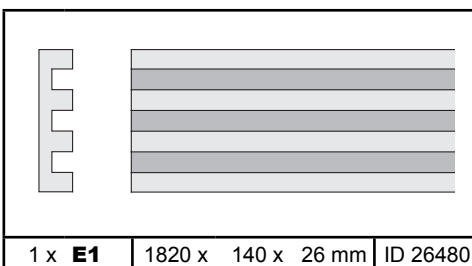
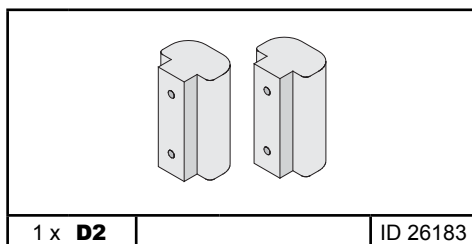
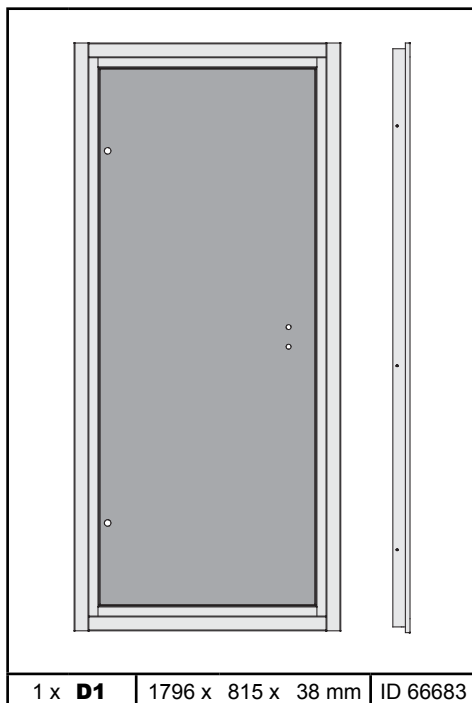
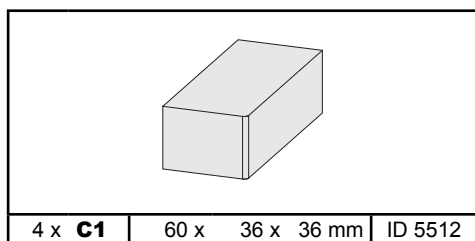
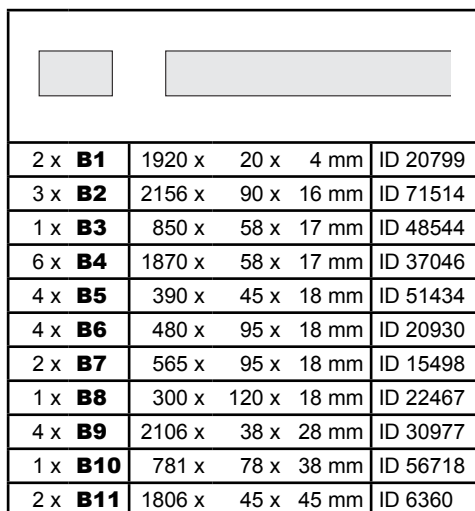
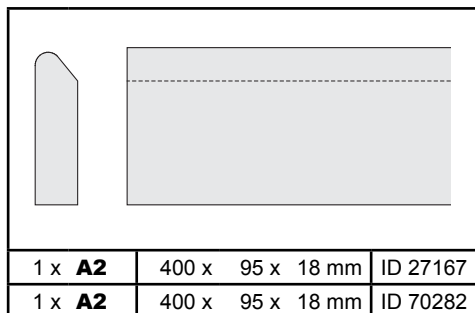
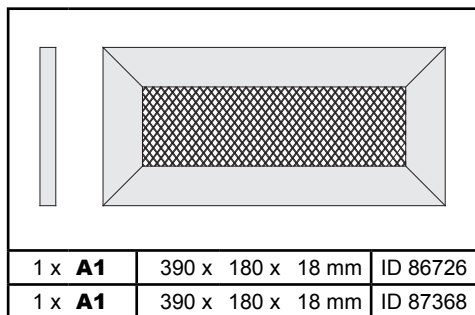
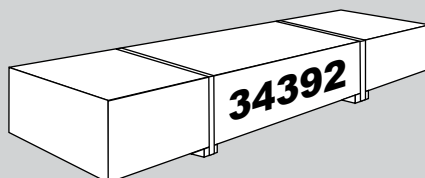

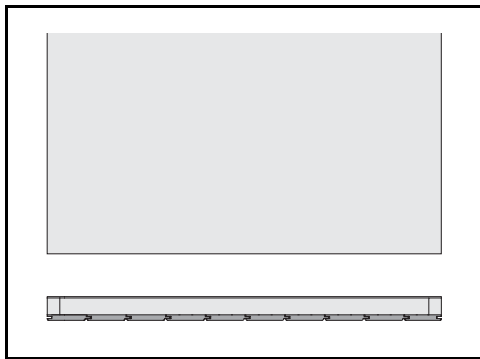

1 x <b>N1</b>	1839 x 349 x 57 mm	ID 53731
1 x <b>N2</b>	1839 x 918 x 57 mm	ID 5986

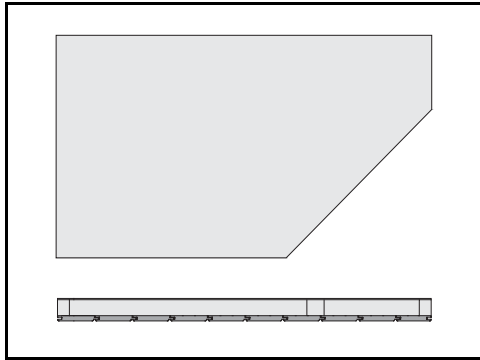

1 x <b>N3</b>	1839 x 918 x 57 mm	ID 21811
---------------	--------------------	----------

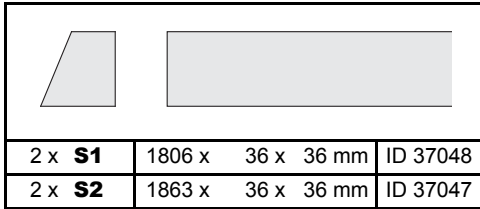

2 x <b>S1</b>	1806 x 36 x 36 mm	ID 37048
2 x <b>S2</b>	1863 x 36 x 36 mm	ID 37047

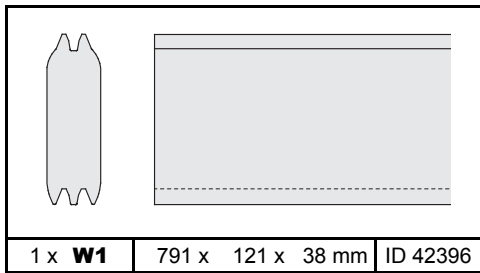

1 x <b>W1</b>	791 x 121 x 38 mm	ID 42396
---------------	-------------------	----------

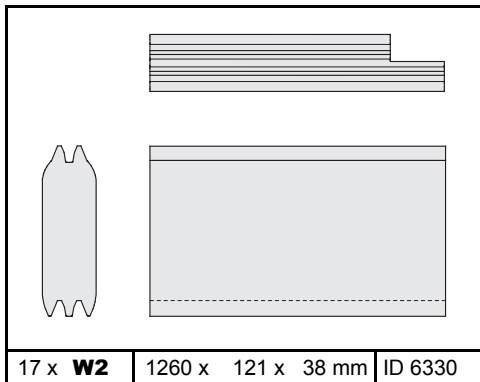

17 x <b>W2</b>	1260 x 121 x 38 mm	ID 6330
----------------	--------------------	---------

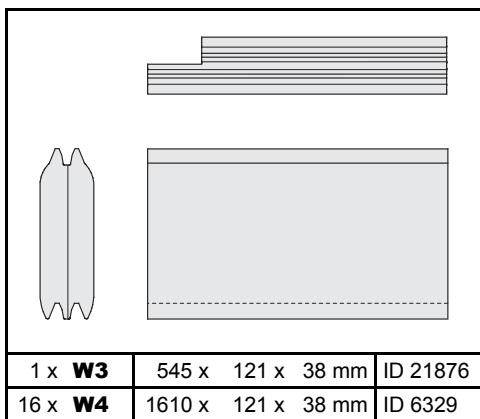

1 x <b>W3</b>	545 x 121 x 38 mm	ID 21876
16 x <b>W4</b>	1610 x 121 x 38 mm	ID 6329

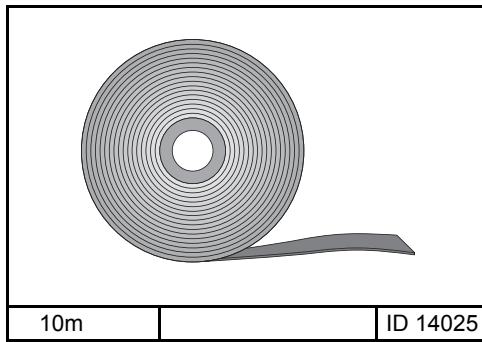

10m		ID 14025
-----	--	----------

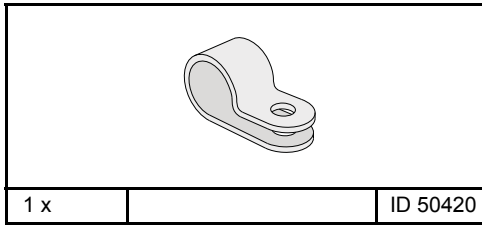

1 x		ID 50420
-----	--	----------

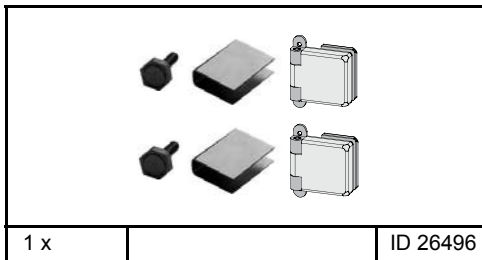

1 x		ID 26496
-----	--	----------

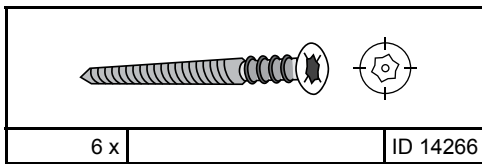

6 x		ID 14266
-----	--	----------

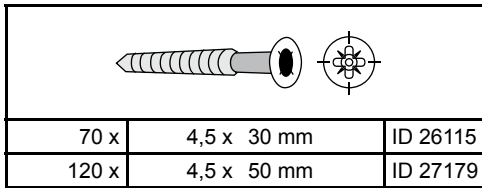

70 x	4,5 x 30 mm	ID 26115
120 x	4,5 x 50 mm	ID 27179

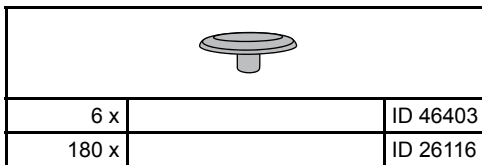

6 x		ID 46403
180 x		ID 26116

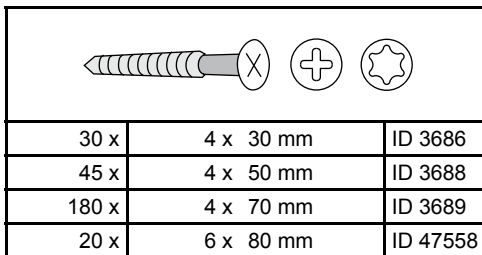

30 x	4 x 30 mm	ID 3686
45 x	4 x 50 mm	ID 3688
180 x	4 x 70 mm	ID 3689
20 x	6 x 80 mm	ID 47558

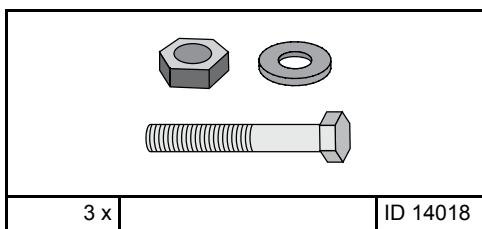

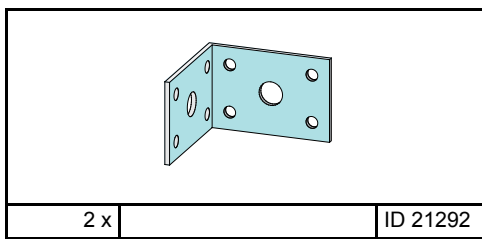

3 x		ID 14018
-----	--	----------



2 x		ID 21292
-----	--	----------

 Übersicht  
 Overview  
 enquête





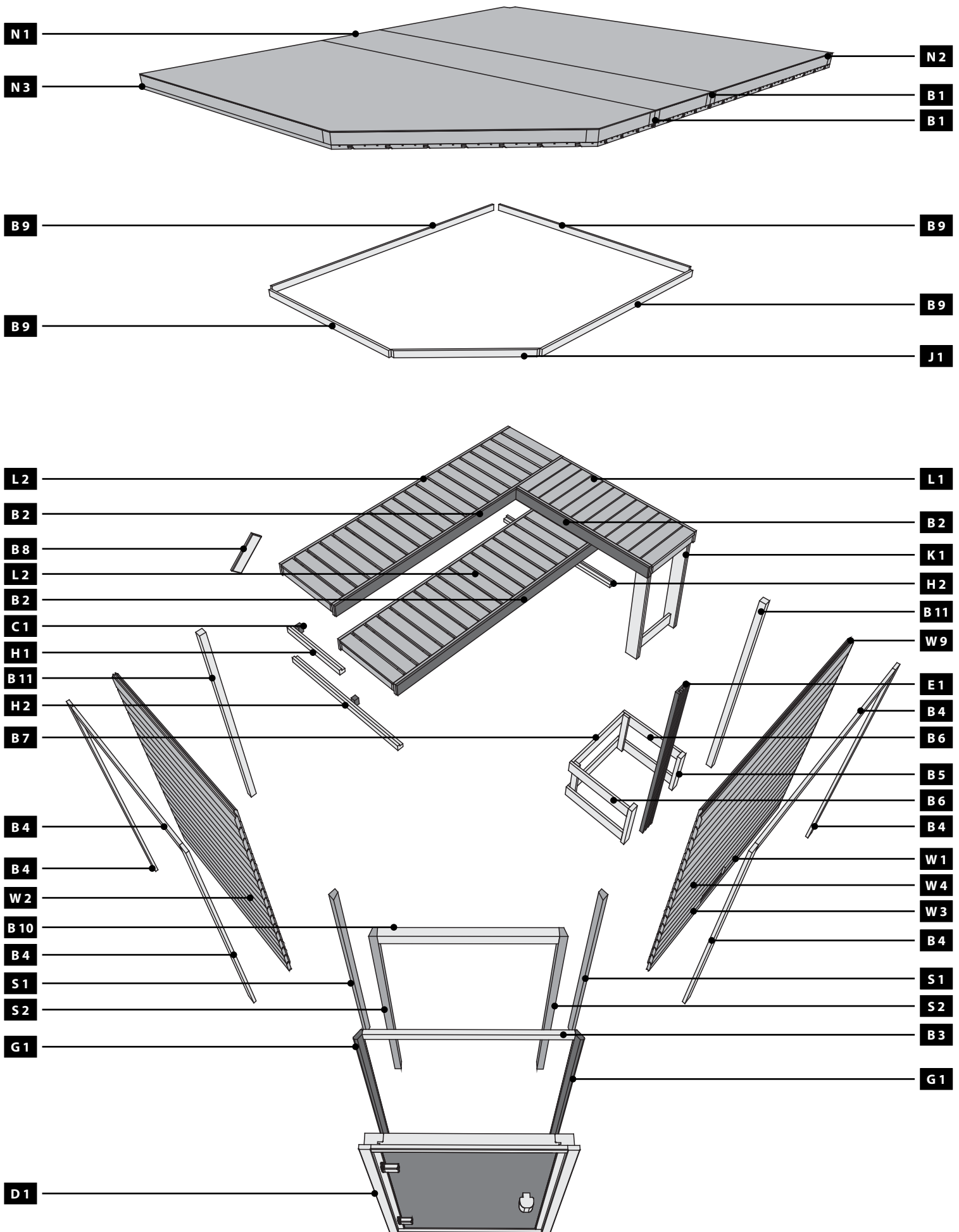

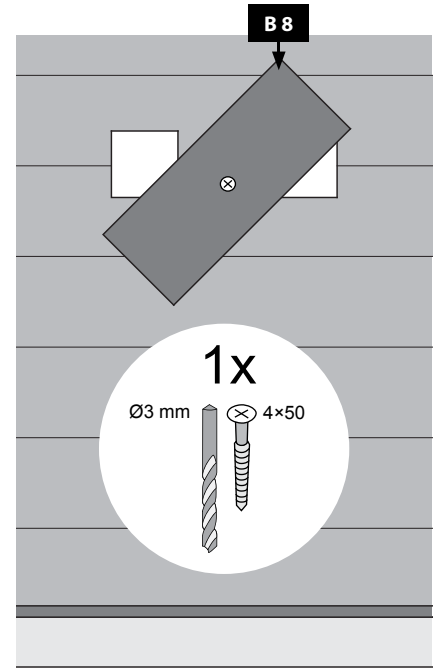
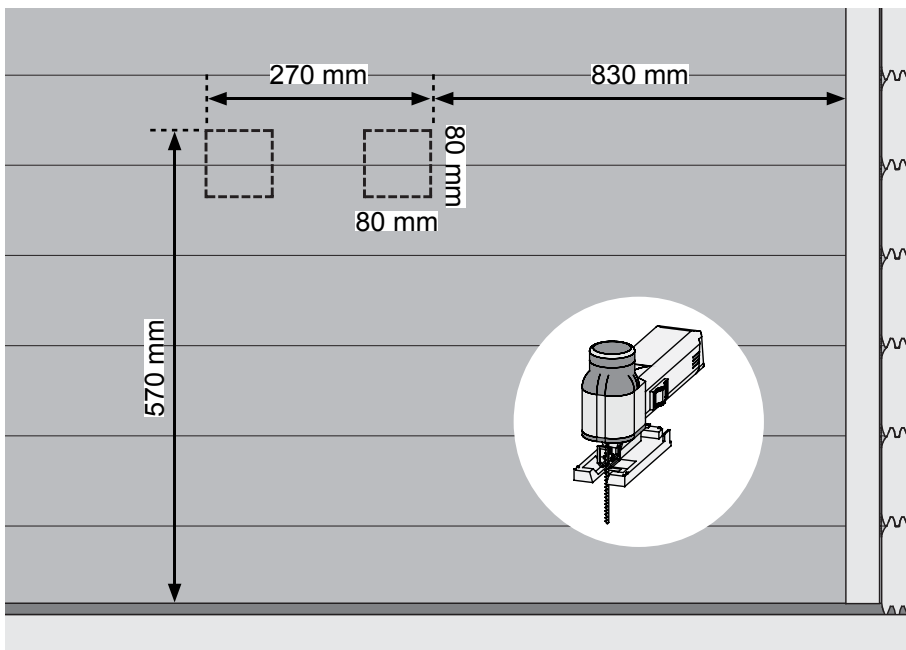
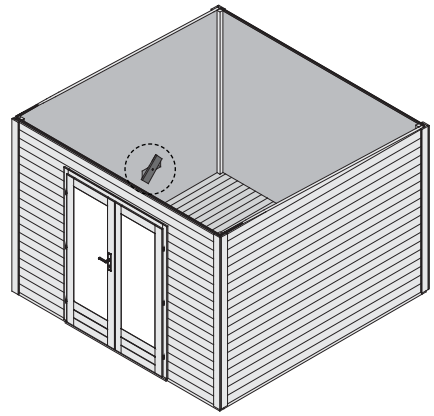
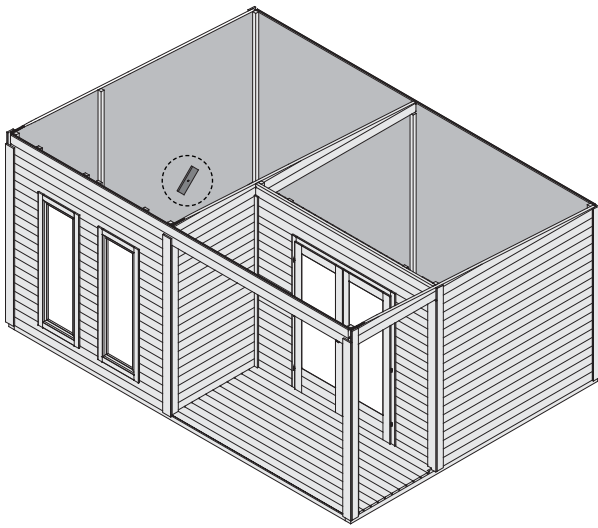

 overzicht  
 undersøgelse  
 estudio

 sondaggio  
 přehled







-  Hier ist die Funktionsweise des Brettes abgebildet. Regeln Sie damit die Abluft nach Ihren eigenen Wünschen
-  This figure shows the functional principle of the board. Regulate the exhaust air according to your own wishes
-  Ceci représente le mode de fonctionnement de la planche. Avec elle, réglez l'écoulement de l'air selon vos désirs
-  Hier is de werking van het plankje afgebeeld. Regel daarmee de luchtafvoer naar eigen wens
-  Sådán fungerer styret. Brug den til at regulere udstødningsluften efter dine egne ønsker
-  Aquí está representada la forma de funcionamiento de la tabla. Regule con ello el aire de salida según sus propios deseos
-  Viene illustrato il principio di funzionamento della tavoletta di regolazione della ventilazione. Con essa si può regolare a piacere la ventilazione
-  Zde je zobrazená funkce desky. Regulujte s ní odsávací vzduch dle Vašeho přání

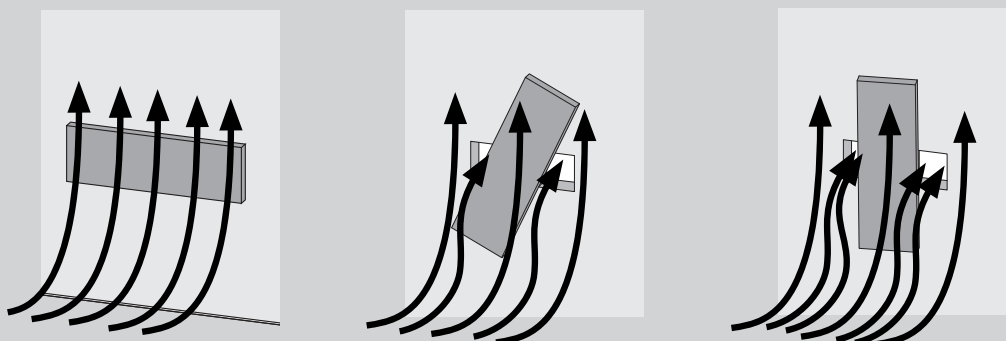

66x

Ø3 mm 4x70

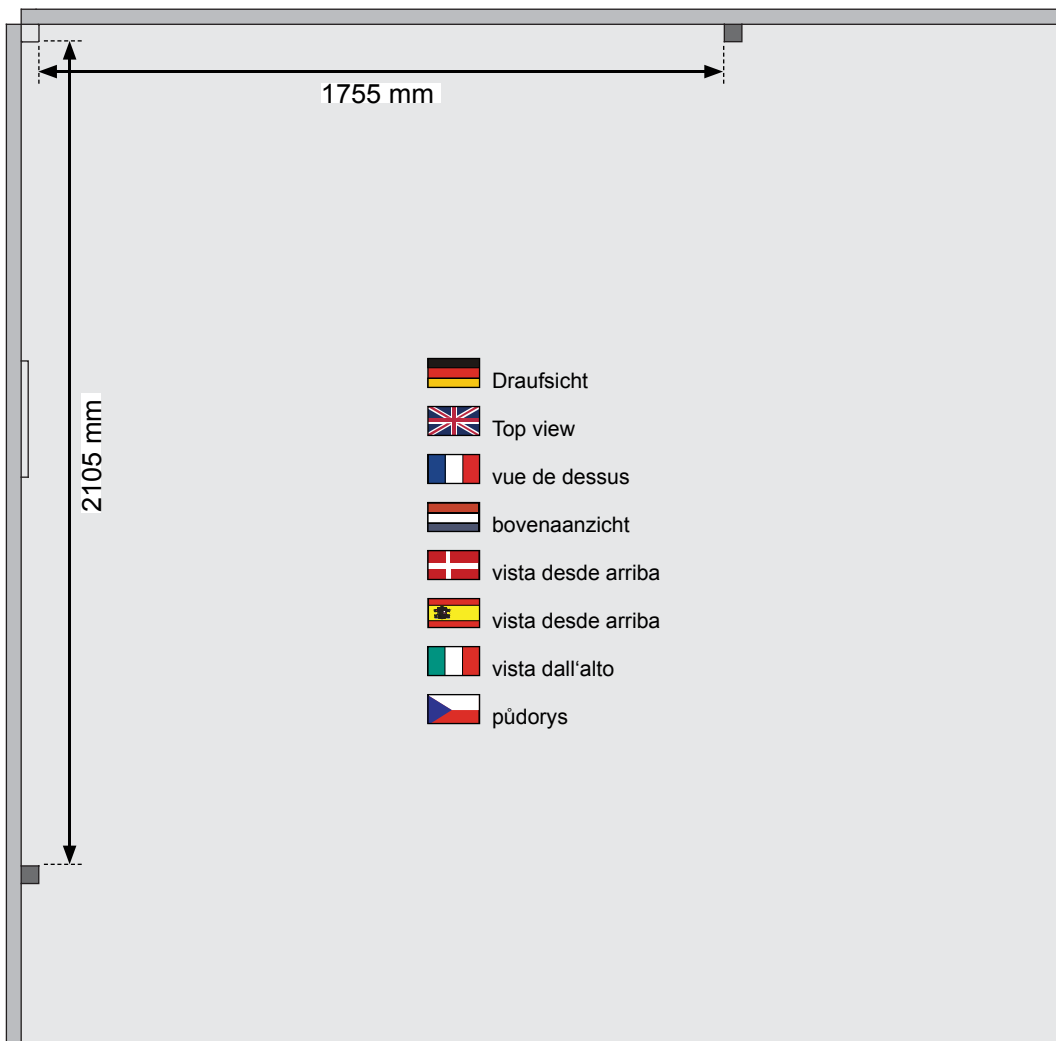
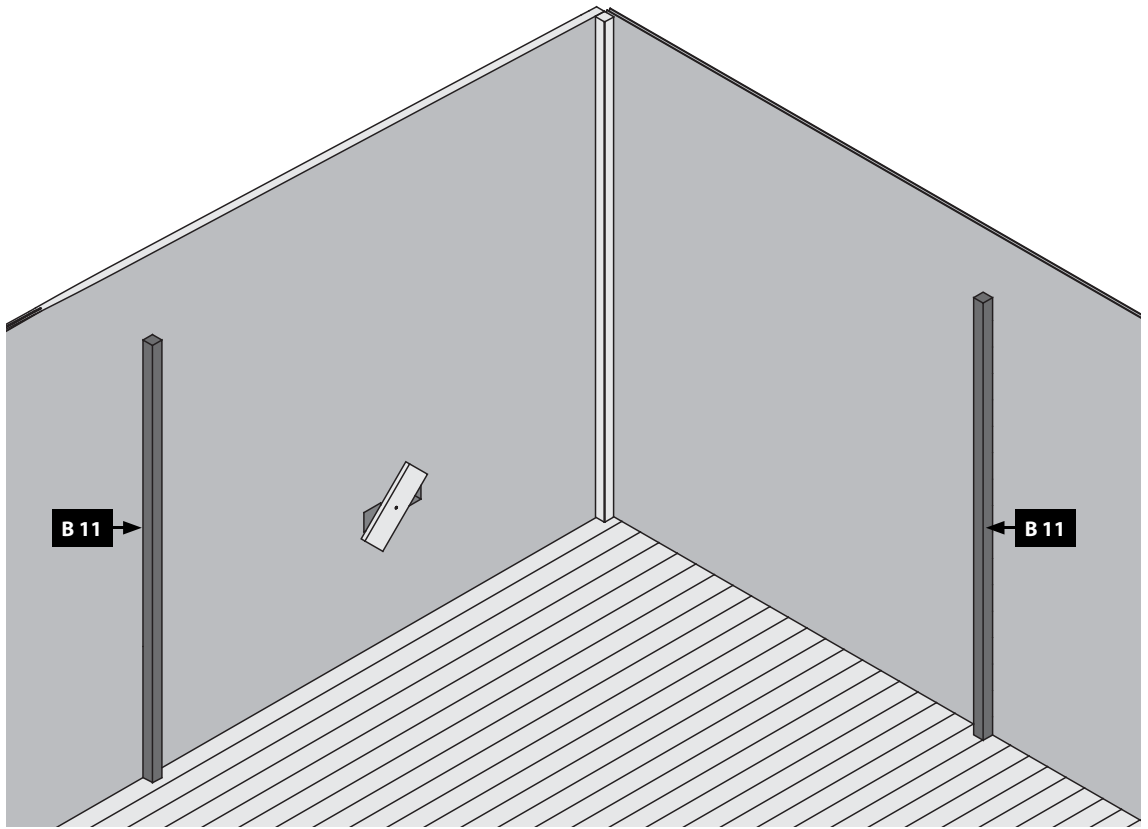
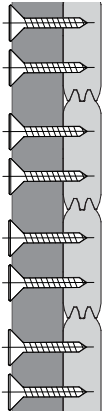
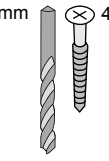

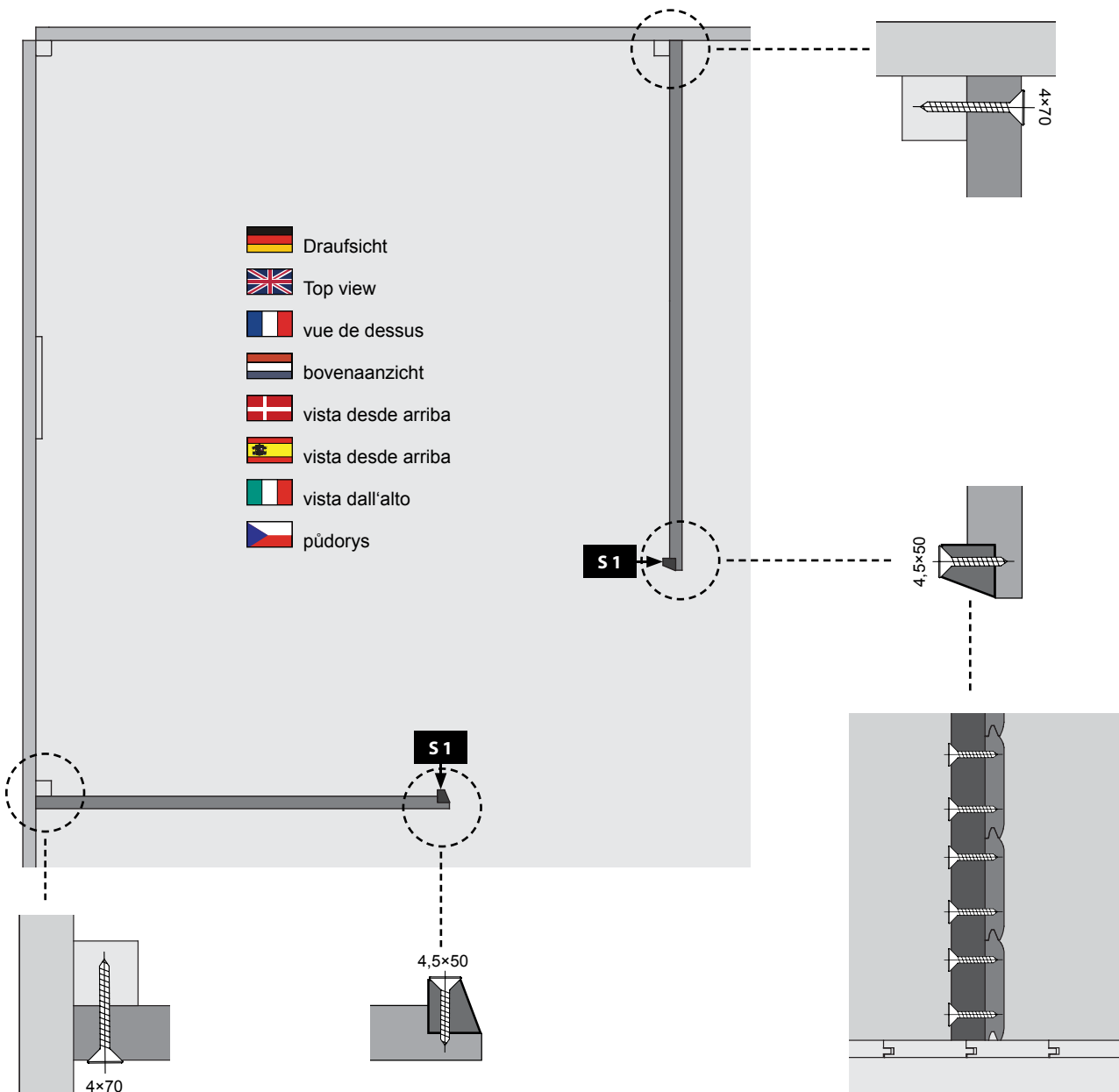
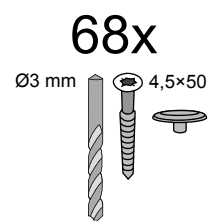
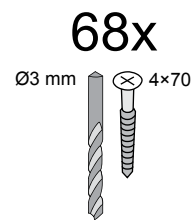
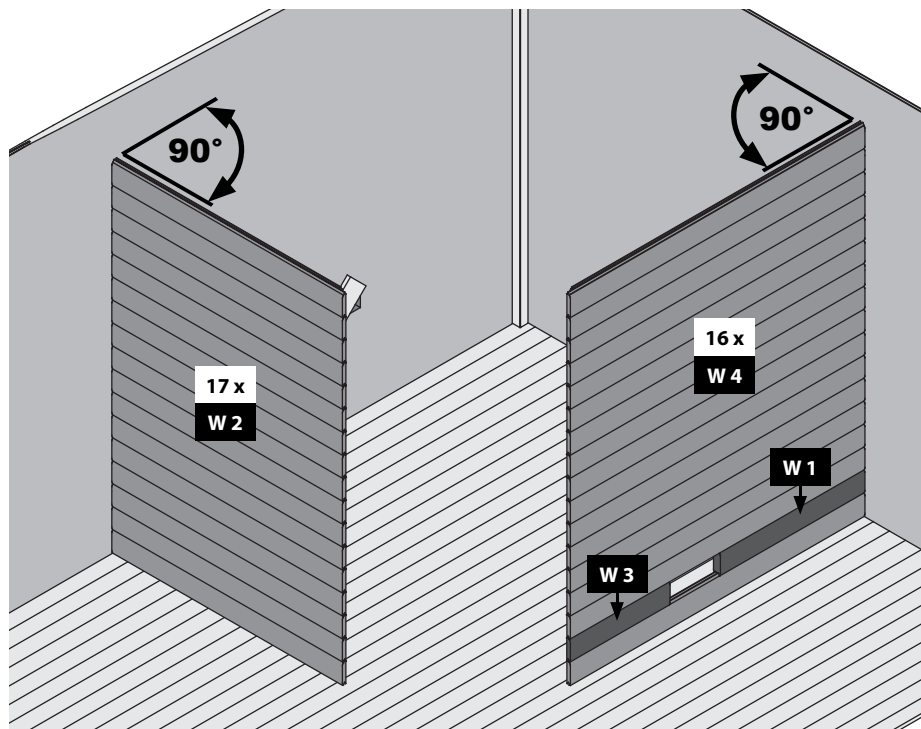

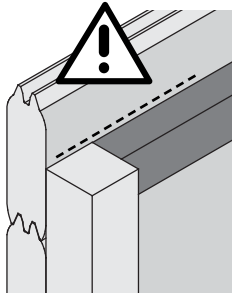

Ø3 mm  
11x  
4,5x50

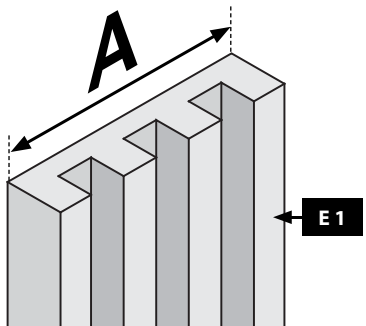
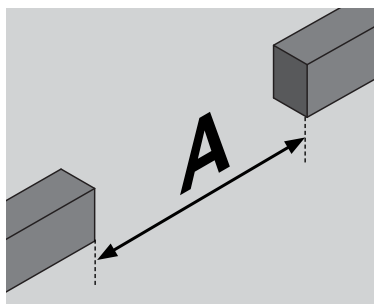
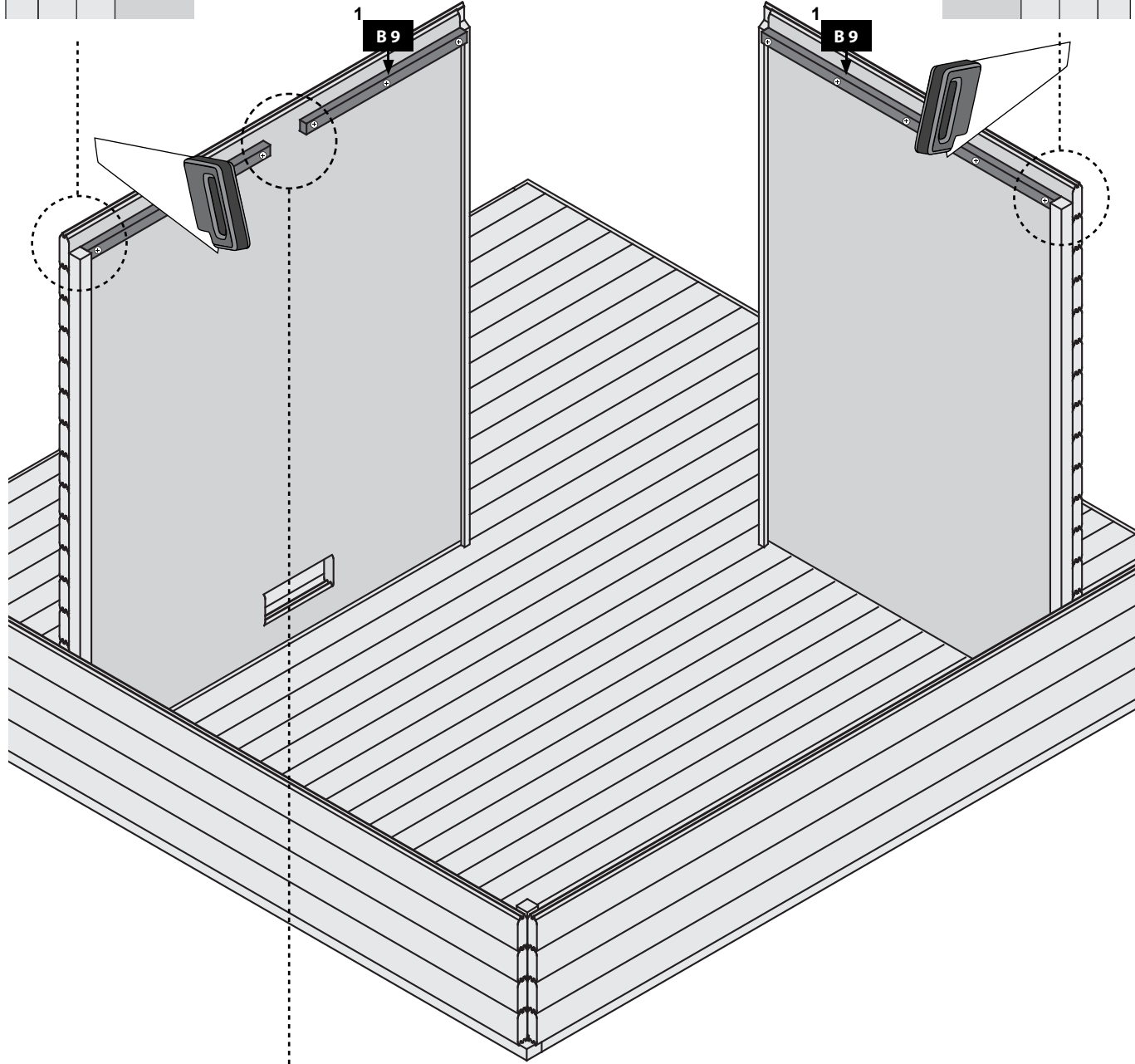
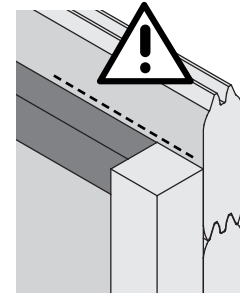
A technical drawing of a 3mm diameter drill bit, a 4.5x50mm screw, and a matching washer.

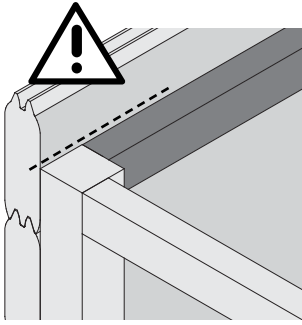
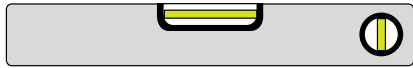

Ø3 mm  
14x  
4,5x50

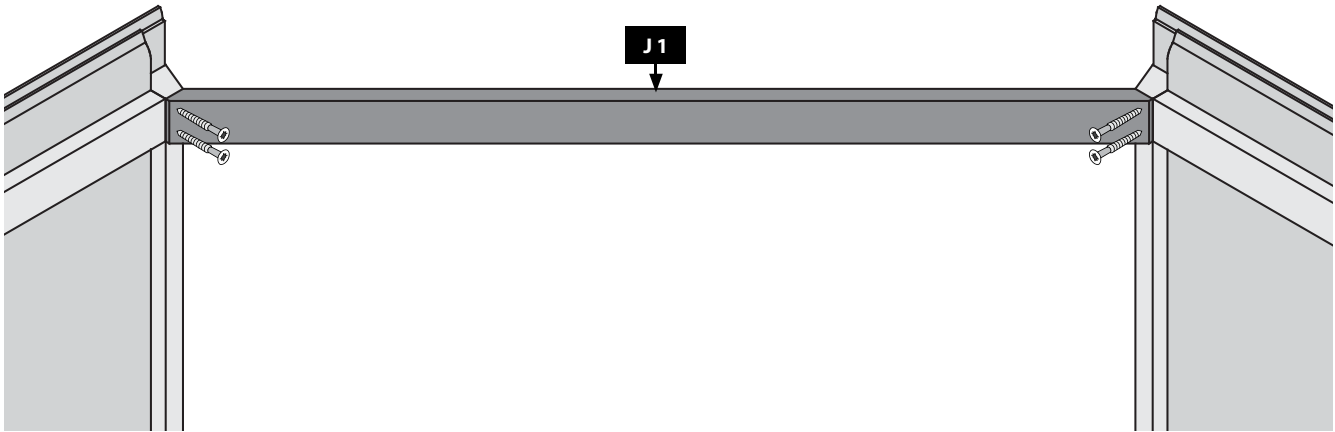
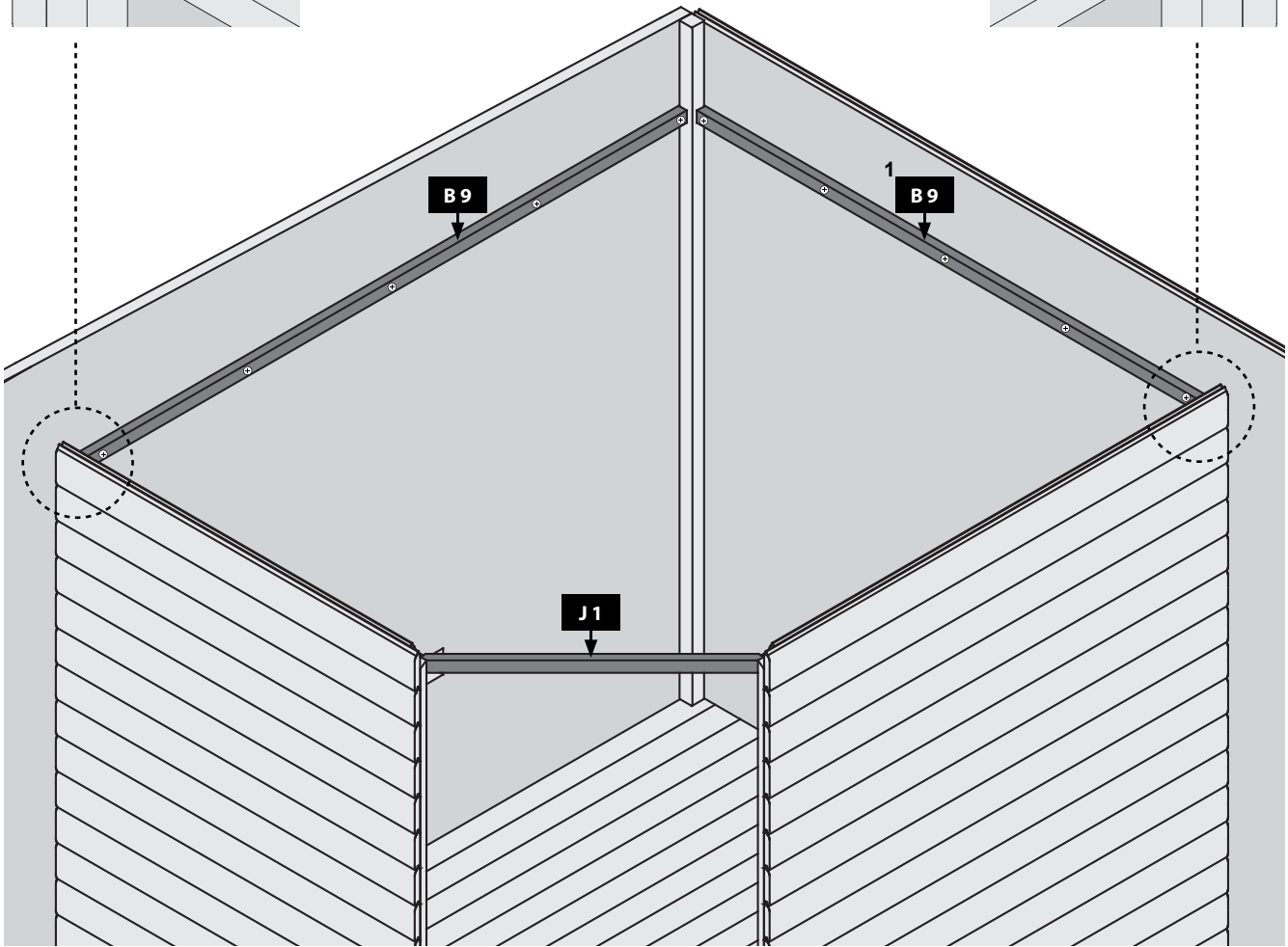
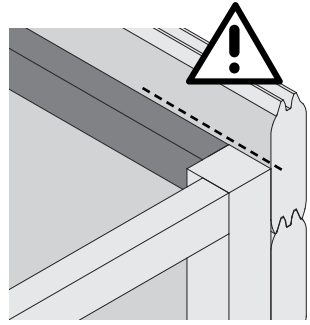
A technical drawing showing a 3mm diameter drill bit, a 4.5x50mm screw, and a washer.

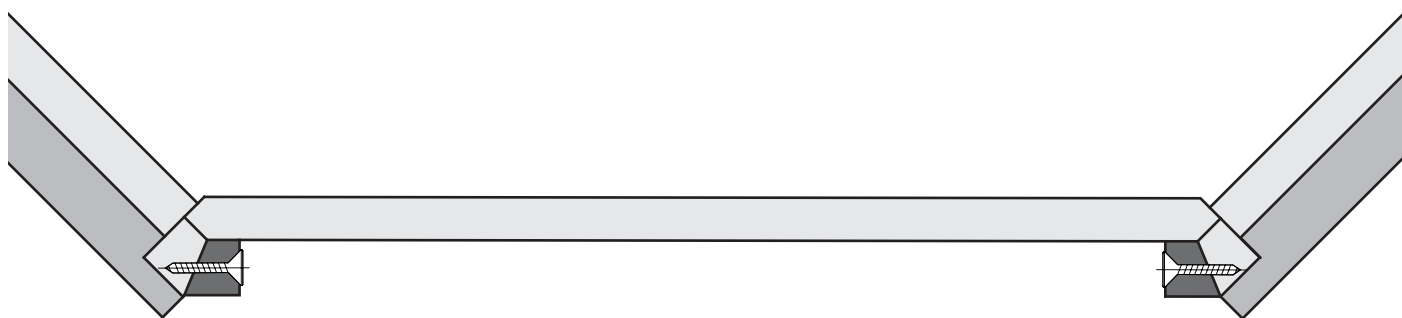
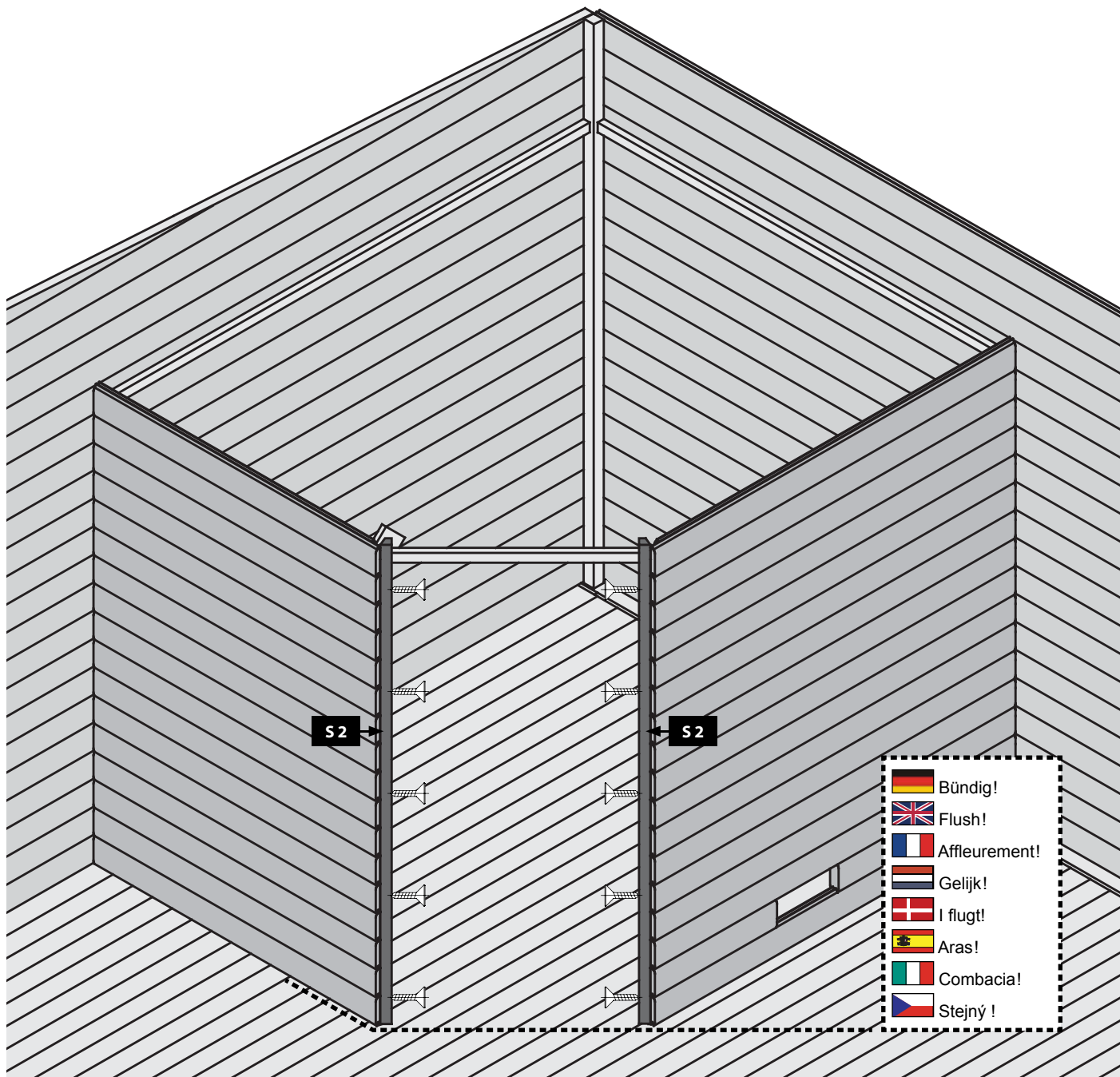





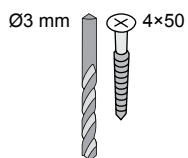

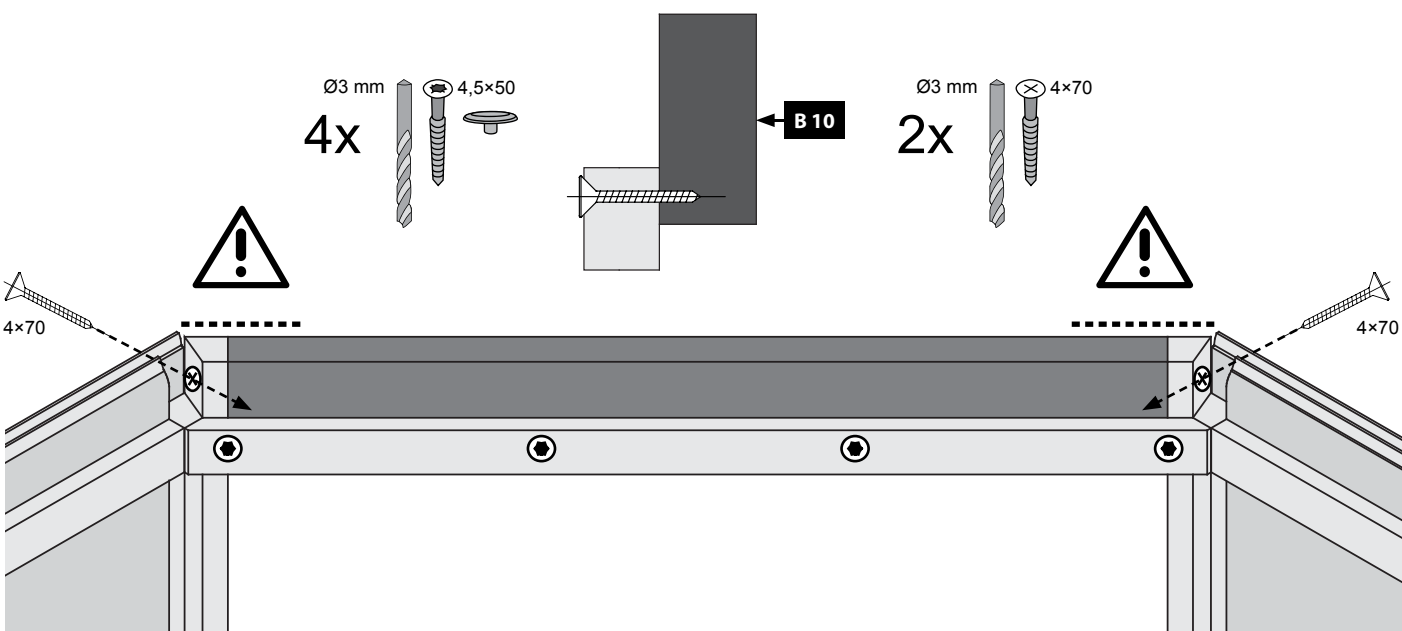
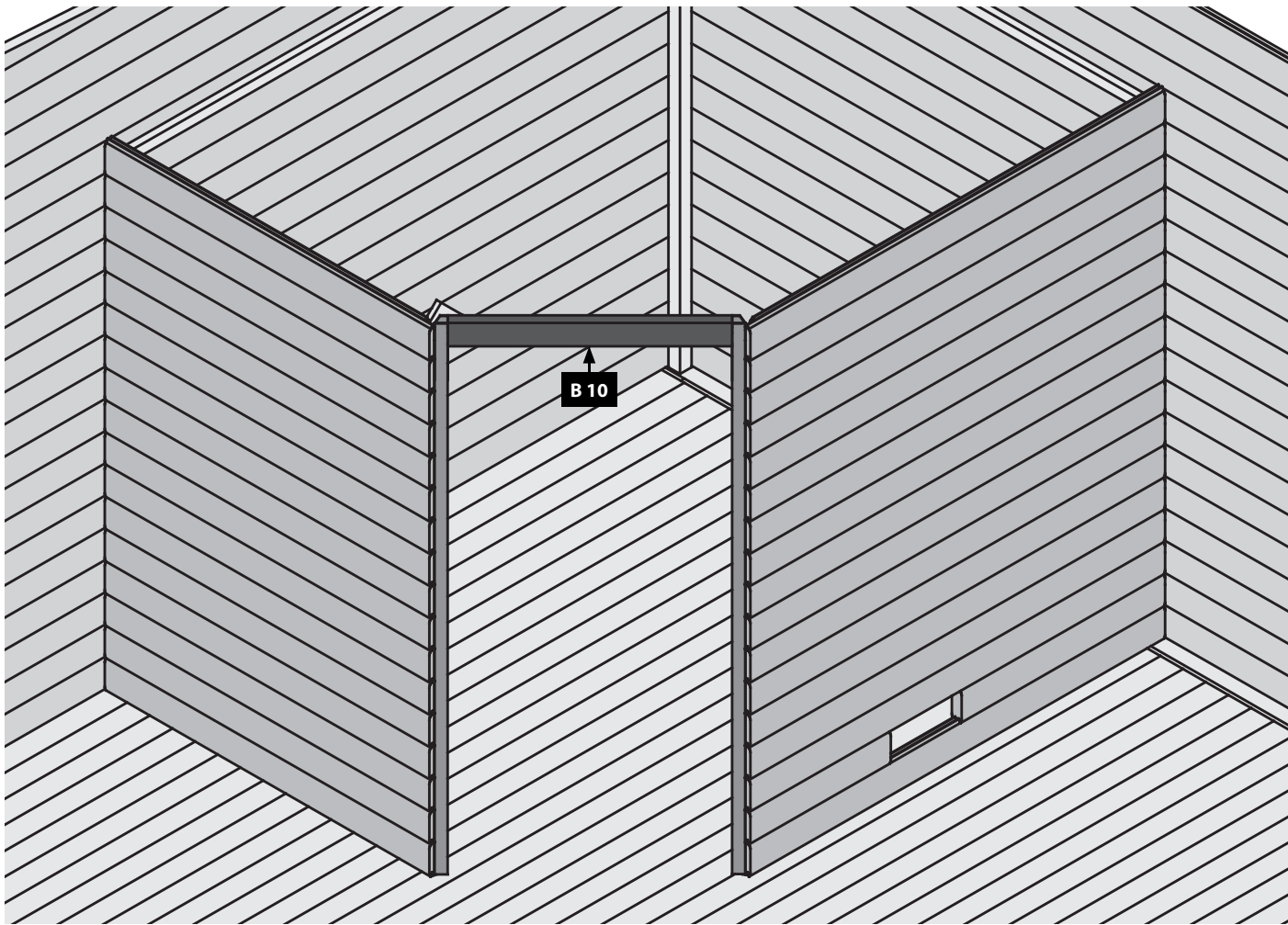

10x

Ø3 mm





-  Einbau Glastür
-  Installation of glass door
-  Montage porte en verre
-  Montage van de glazen deur

-  Installationsglasdør
-  Montaje de la puerta de cristal
-  Installazione portello di vetro
-  Sauna Instalace dveře

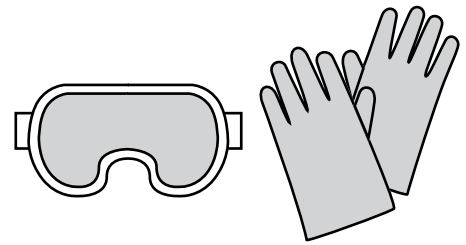

08

-  Saunatürglas in den Türrahmen legen
-  Put the door glass in the frame
-  Mettez le verre de la porte dans le cadre
-  Plaats het deurglas in het frame
-  Sæt dørglasset i rammen
-  Pon el vidrio de la puerta en el marco
-  Metti il vetro della porta nel telaio
-  Vložte sklo dveří do rámu

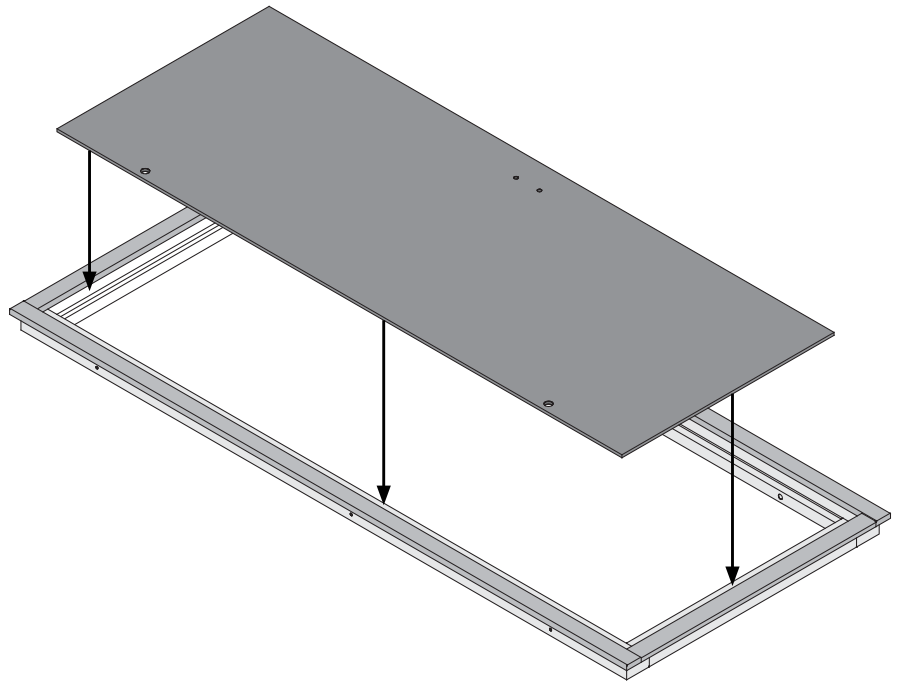

-  Saunatürglas in den Türrahmen ausrichten
-  Center the glass in the wooden frame
-  Bien aligner le verre à vitre
-  Lijn het glas uit in het deurframe
-  Juster saunaens dørglas i dørkarmen
-  Alinee el vidrio en el marco de la puerta
-  Allineare il vetro nel telaio della porta
-  Skleněná dvířka sauna v zárubně zarovnat

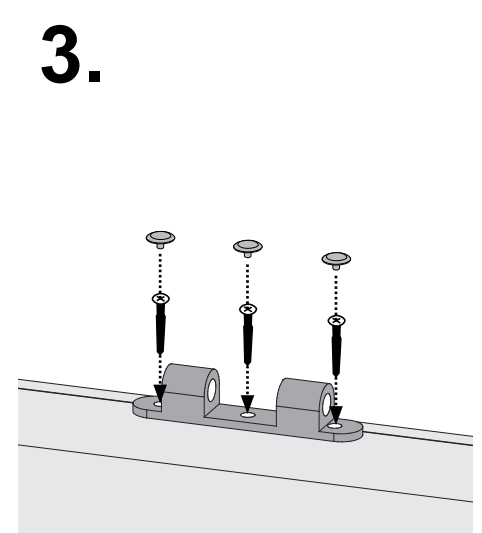
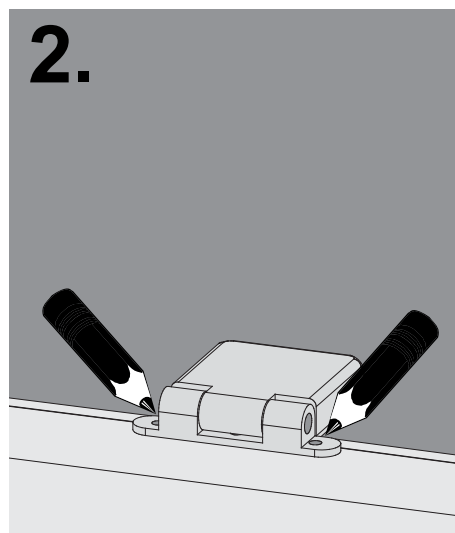
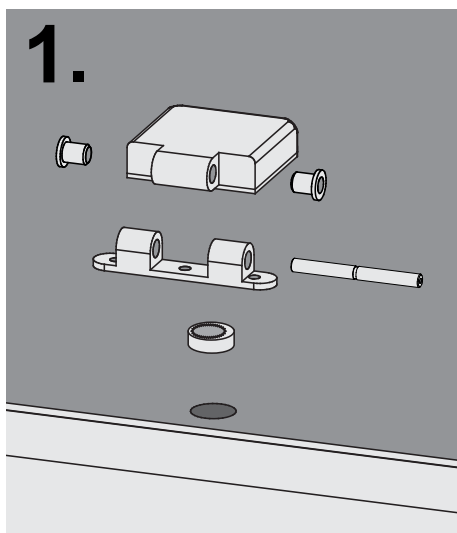
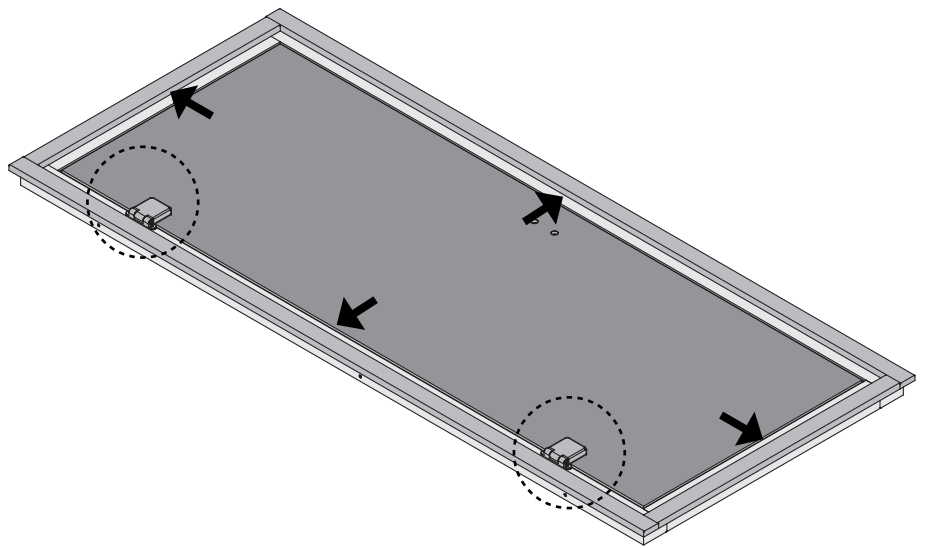



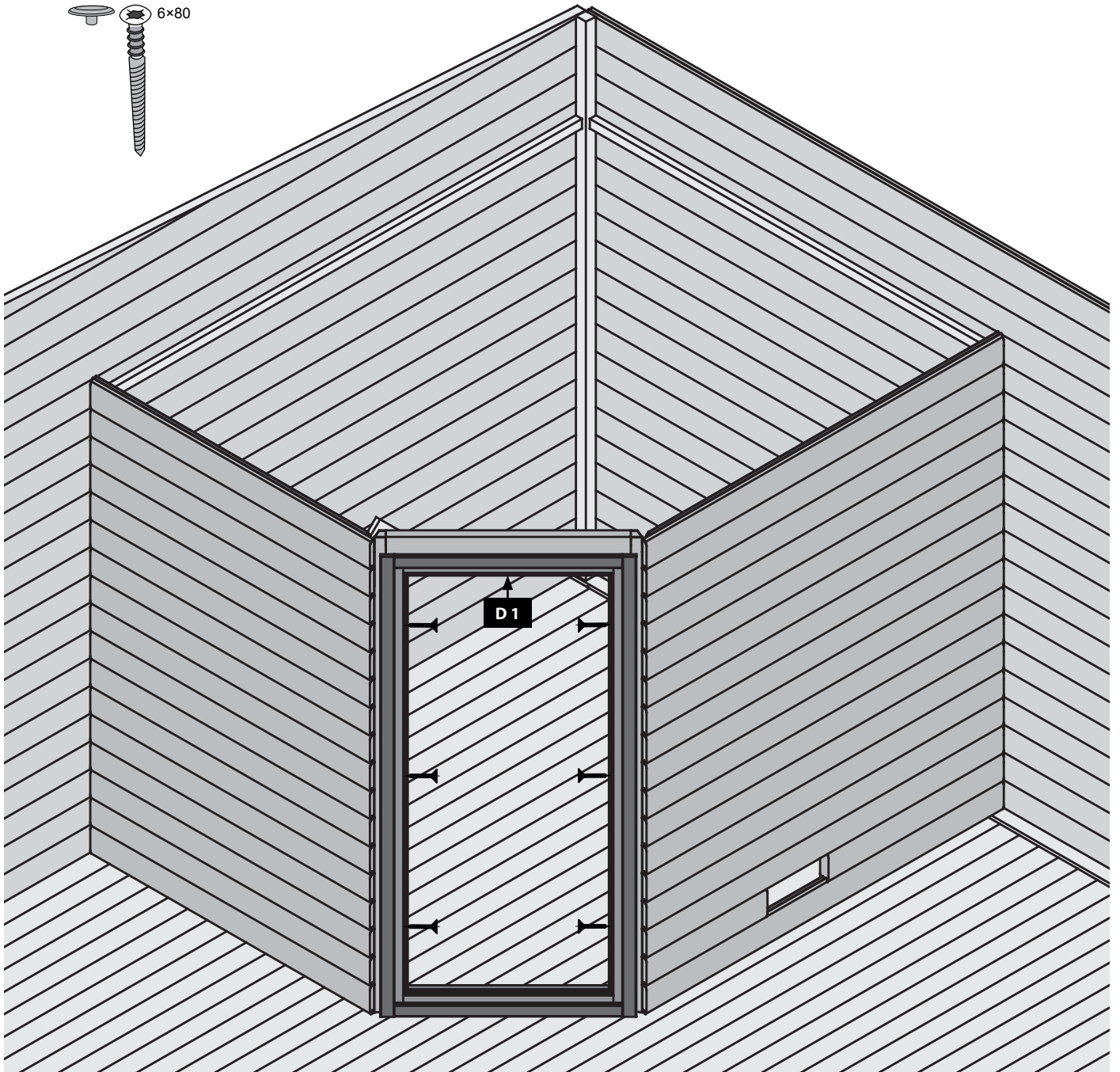
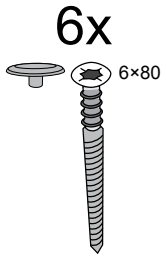

1.

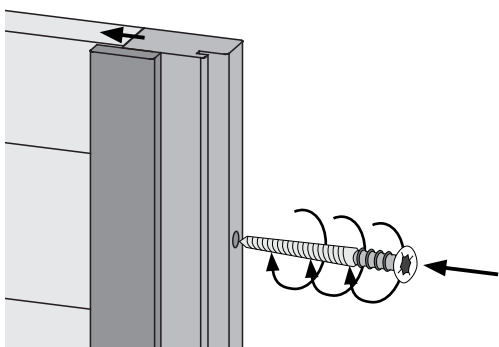

2.

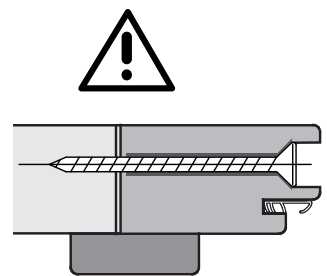
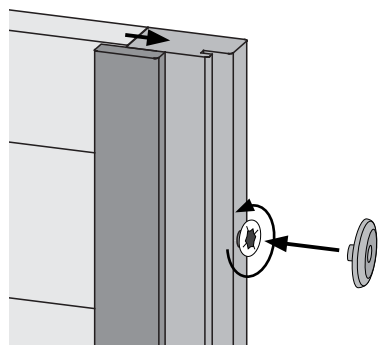

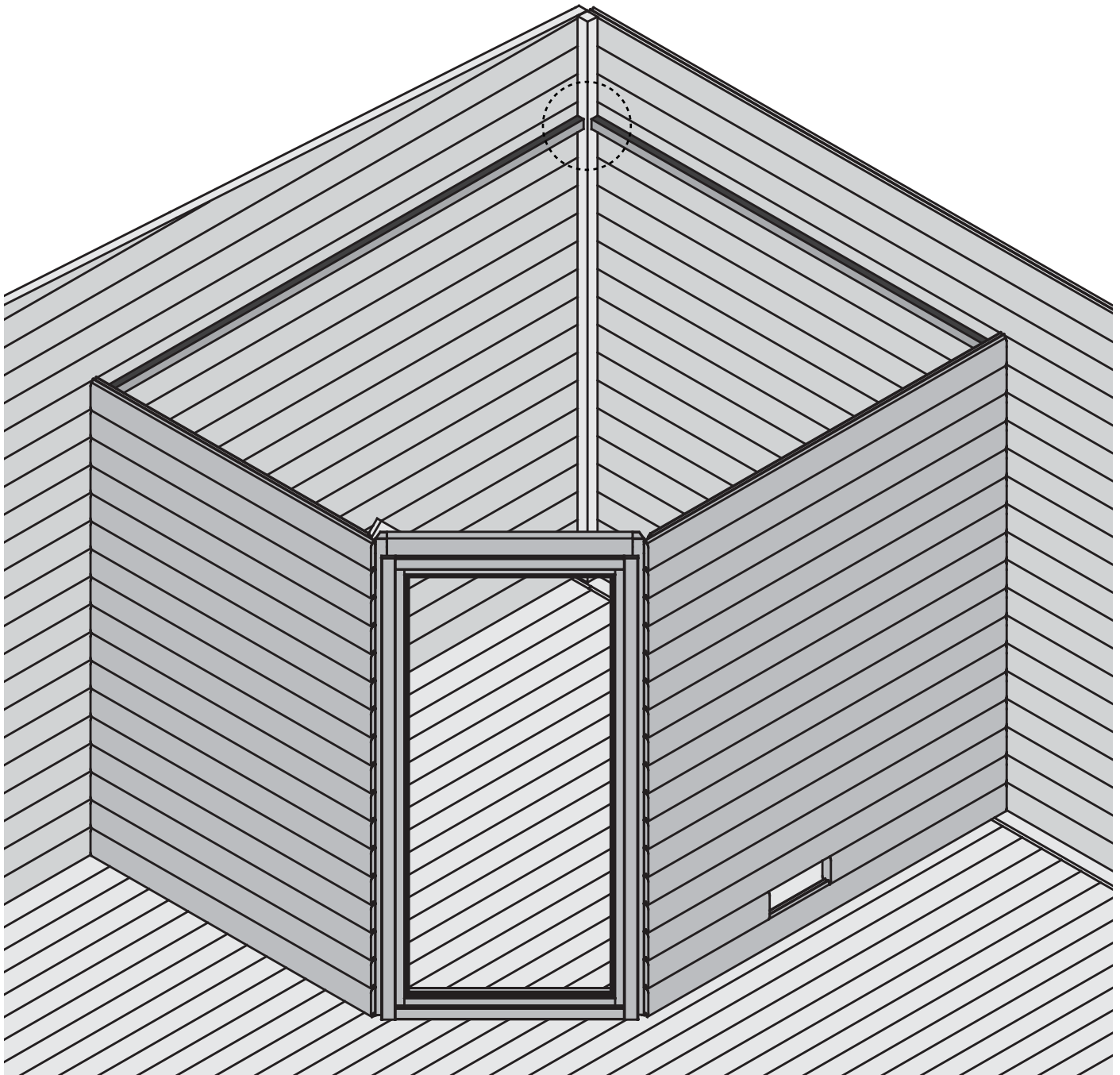



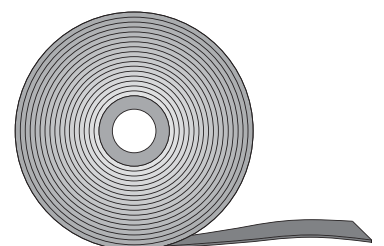
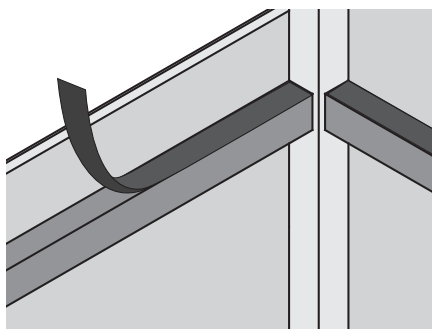

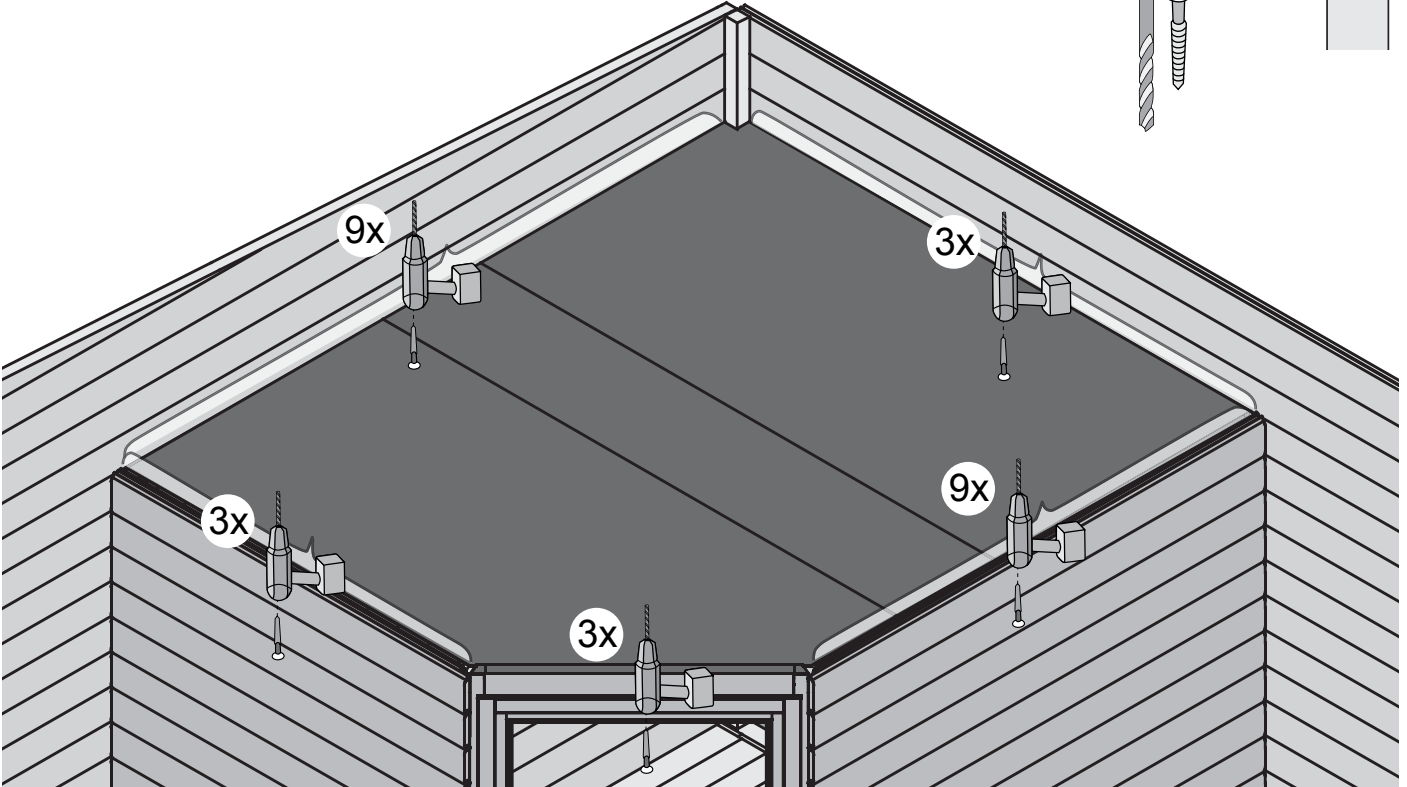
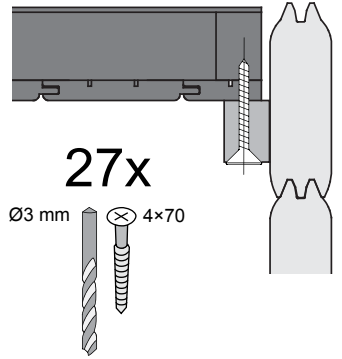
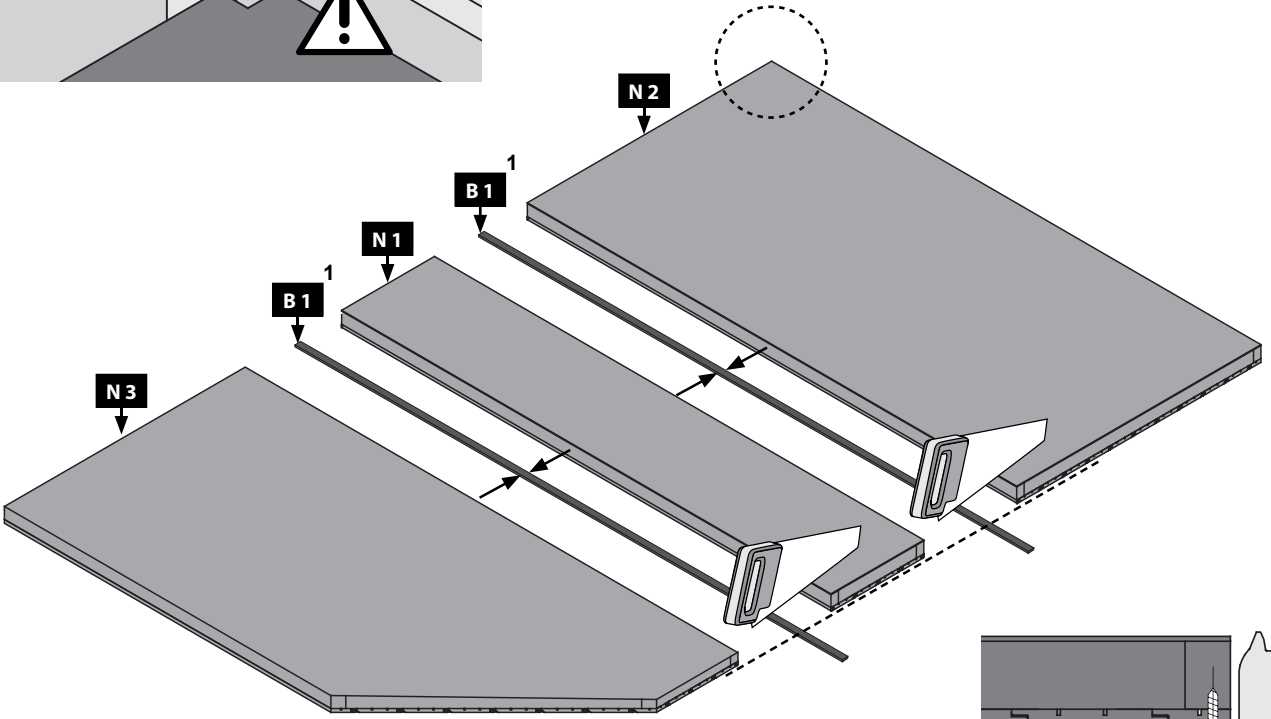
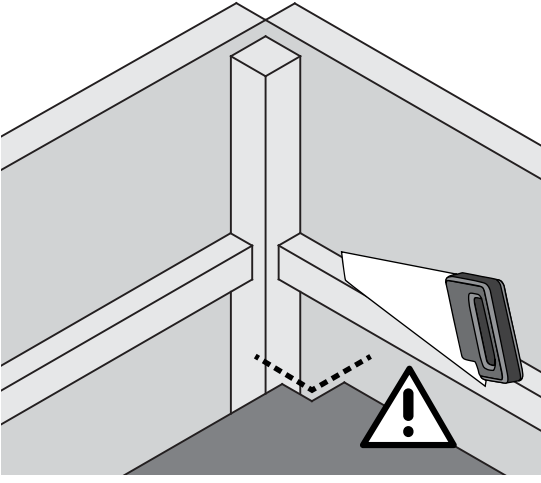
-  Sauna Dichtband
-  Sauna sealing tape
-  Ruban d'étanchéité pour sauna
-  Sauna tætningsbånd
-  Sauna abdichtungstape
-  Cinta de sellado de sauna
-  Nastro sigillante per sauna
-  Sauna těsnící páska

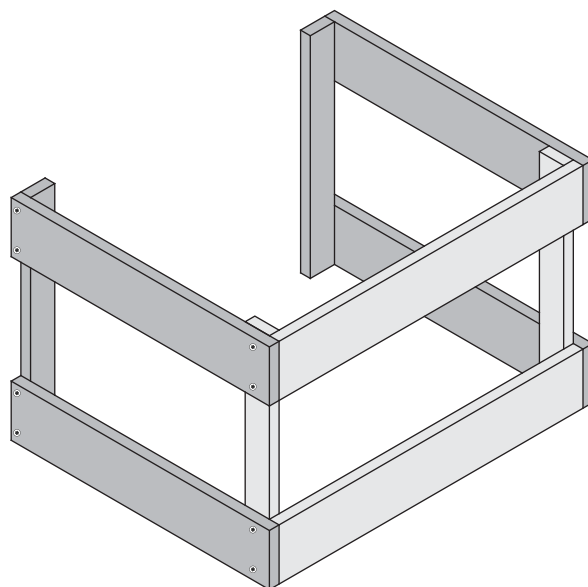
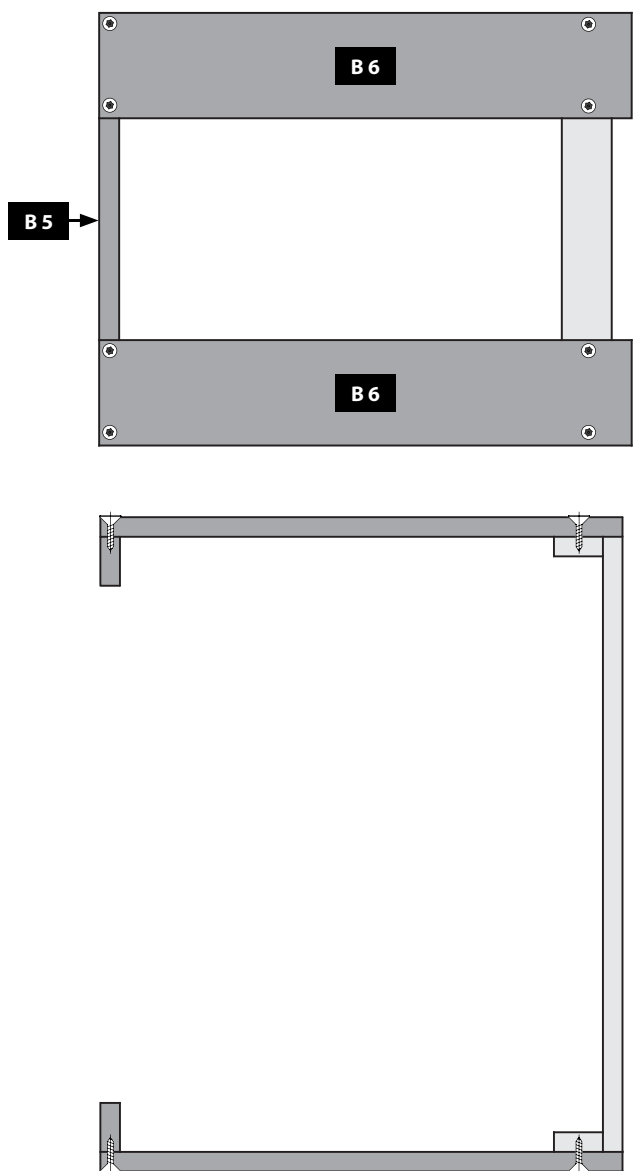
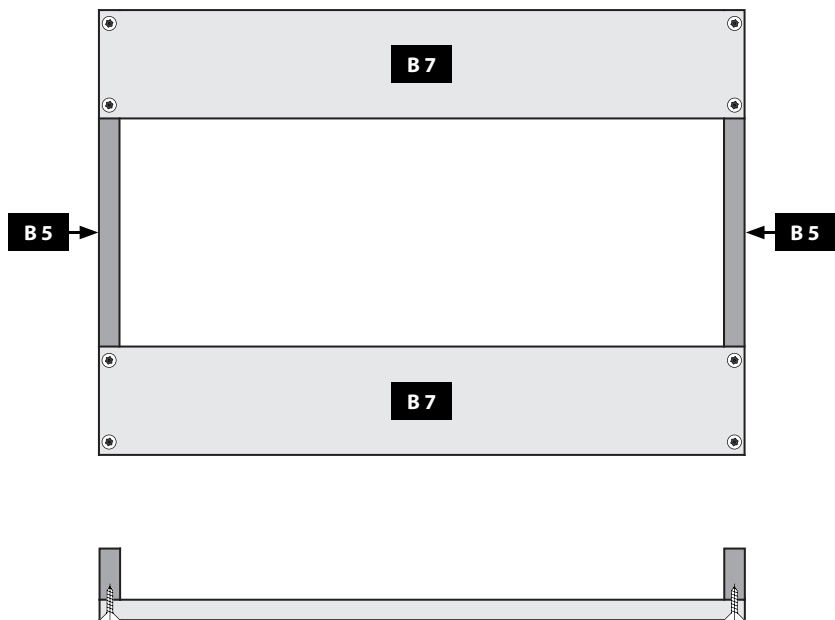

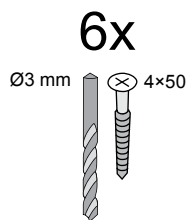
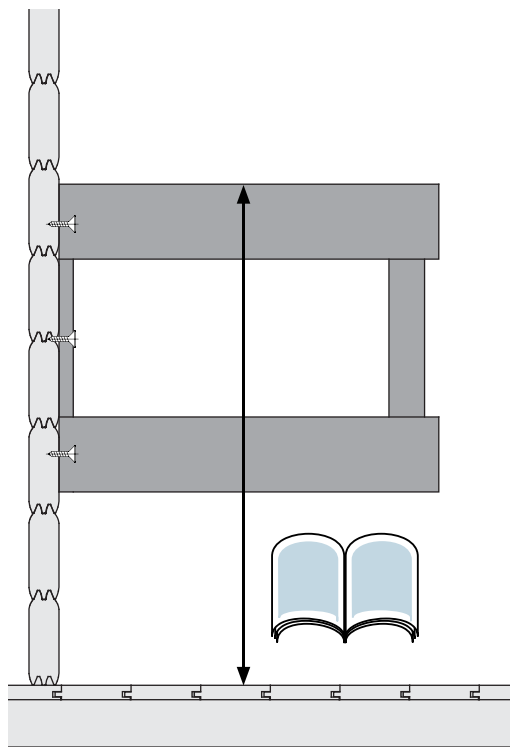
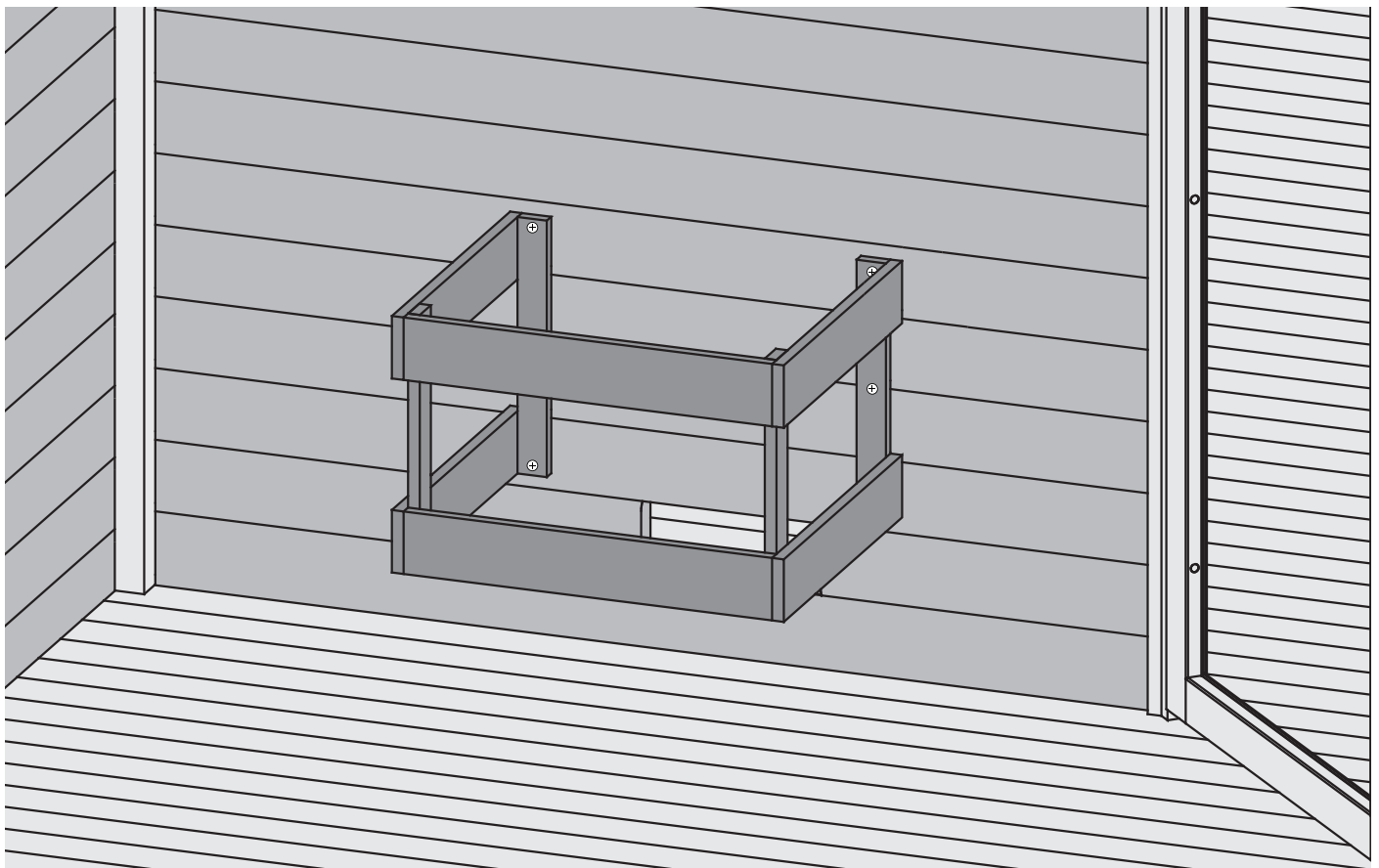









-  Höhe aus Ofenanleitung entnehmen
-  Take the height from the oven instructions
-  Prenez la hauteur des instructions du four
-  Neem de hoogte uit de oveninstructies

-  Tag højden fra ovenvejledningen
-  Tome la altura de las instrucciones del horno
-  Prendere l'altezza dalle istruzioni del forno
-  Výšku vezměte z návodu k troubě

Saunatyp 38mm  
Steuerung extern extern

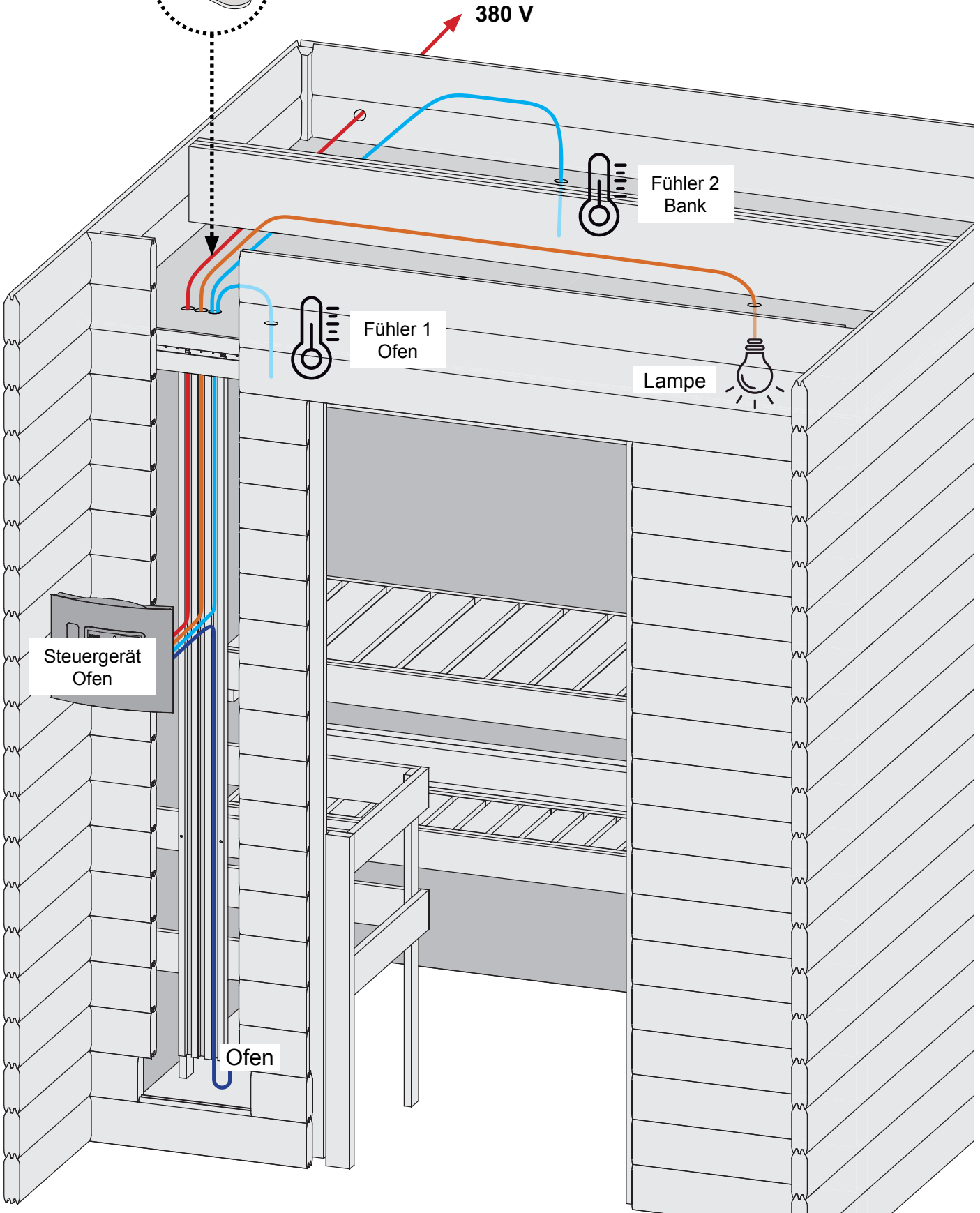
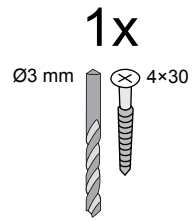



Ø3mm 4,5x50

8x

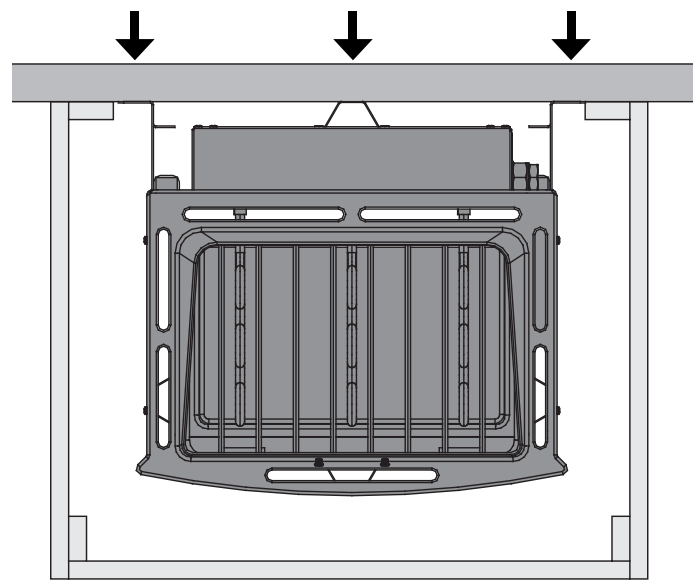
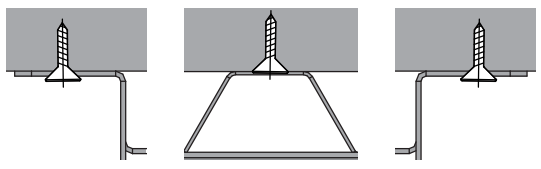
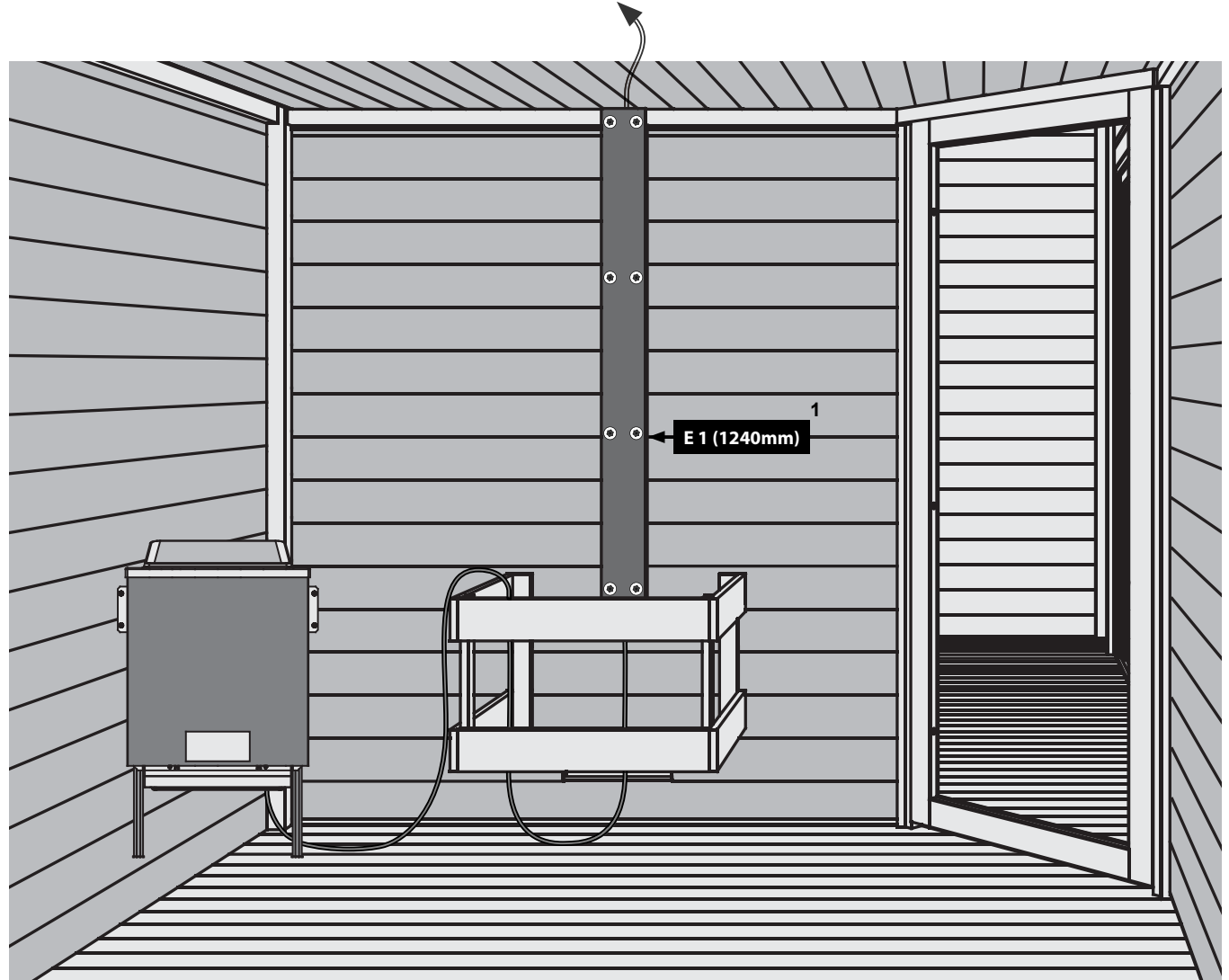
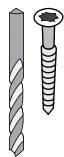

-  Ofenbefestigung
-  oven fixing
-  fixation four
-  oven vaststelling
-  ovn fastsættelse
-  fijación horno
-  fissaggio forno
-  upevňovací trouba

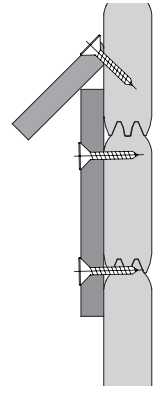
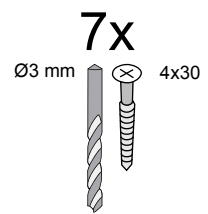
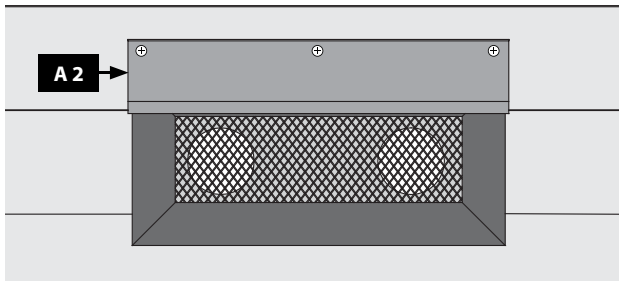
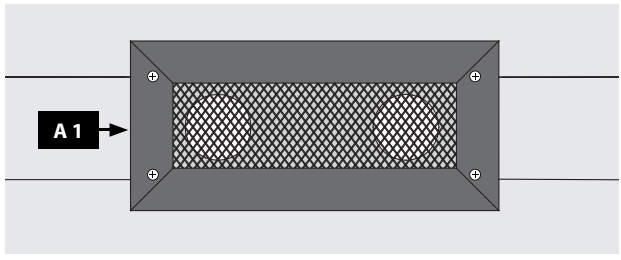
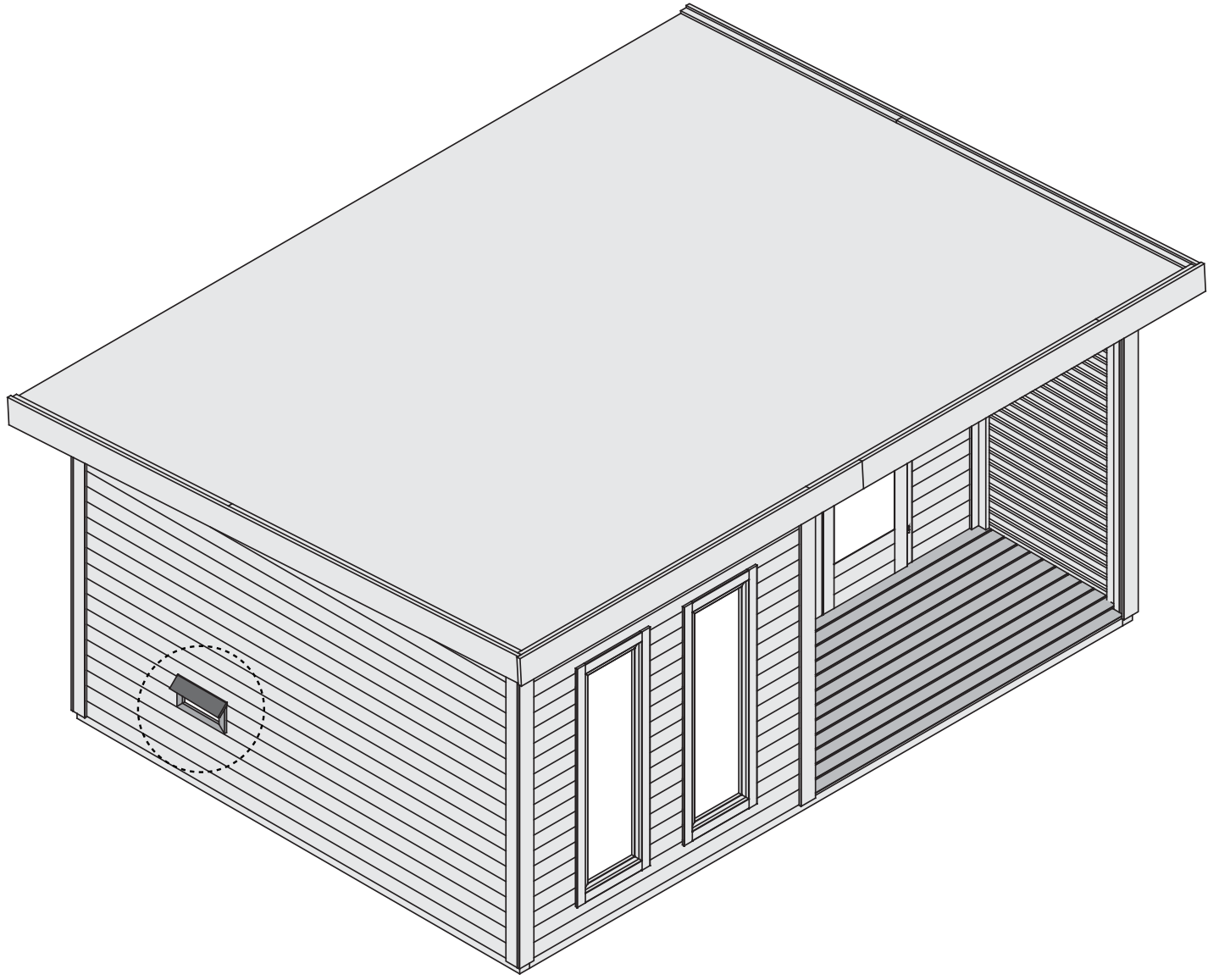



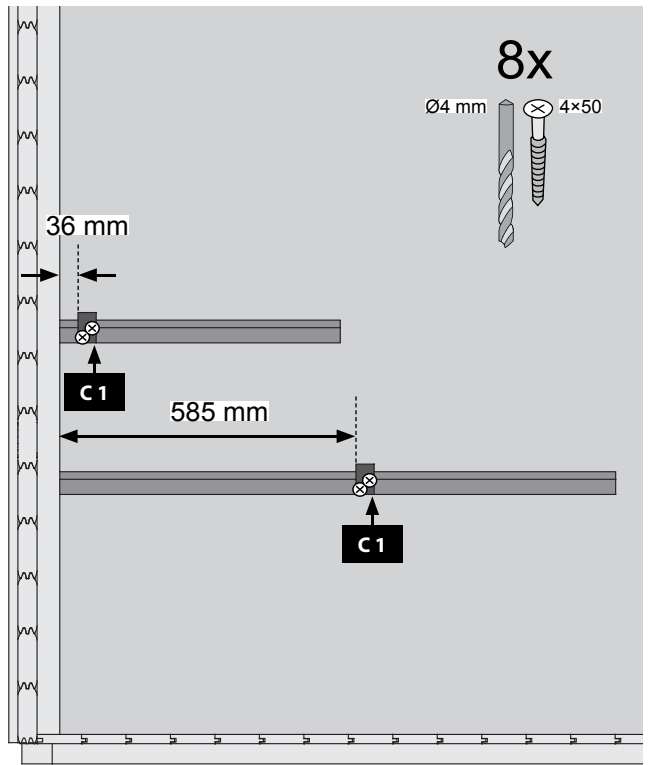
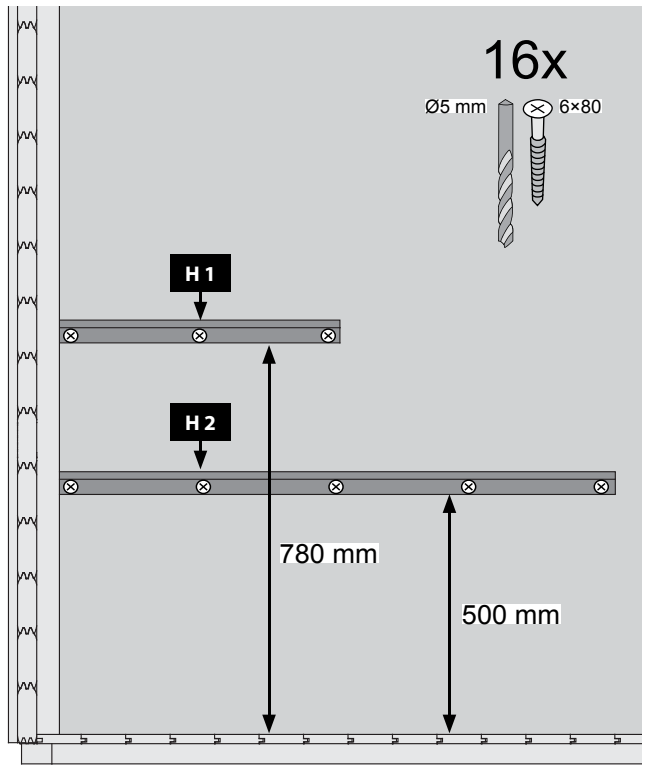
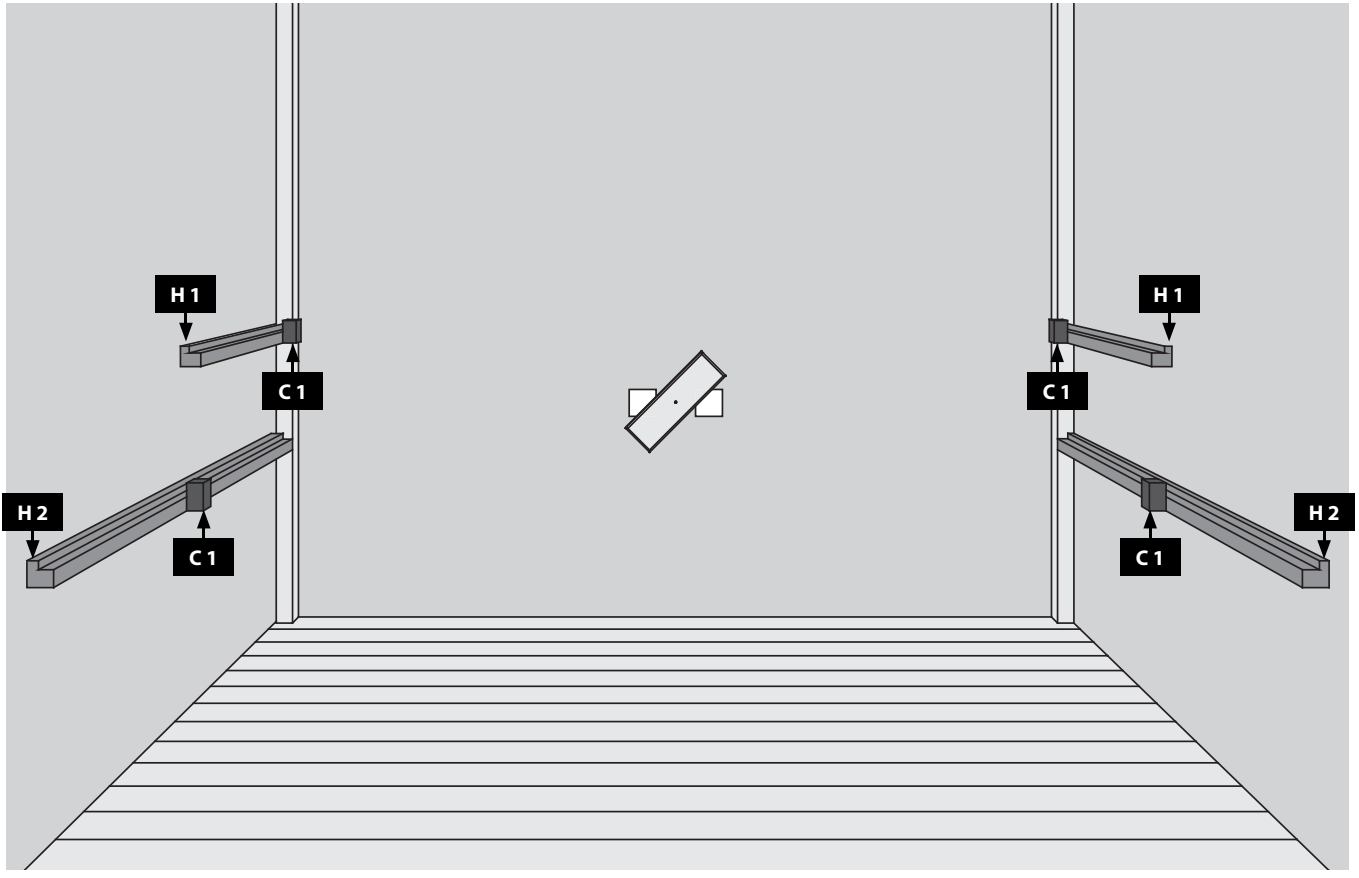

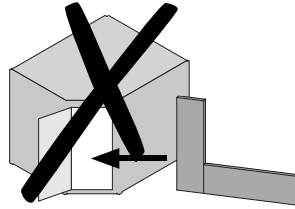
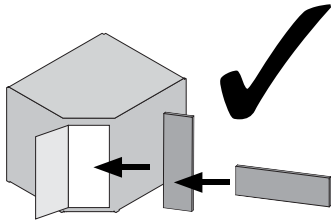
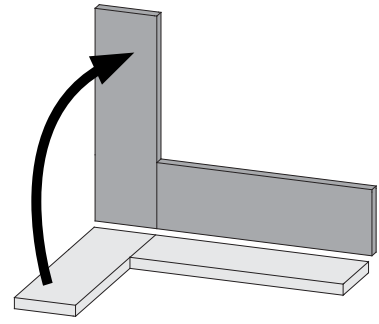
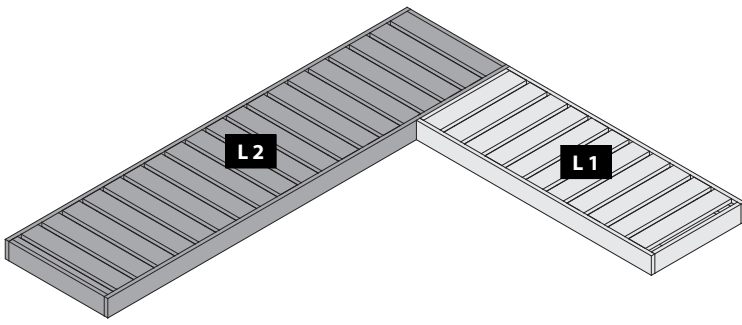

19

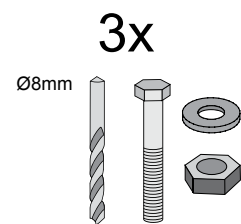
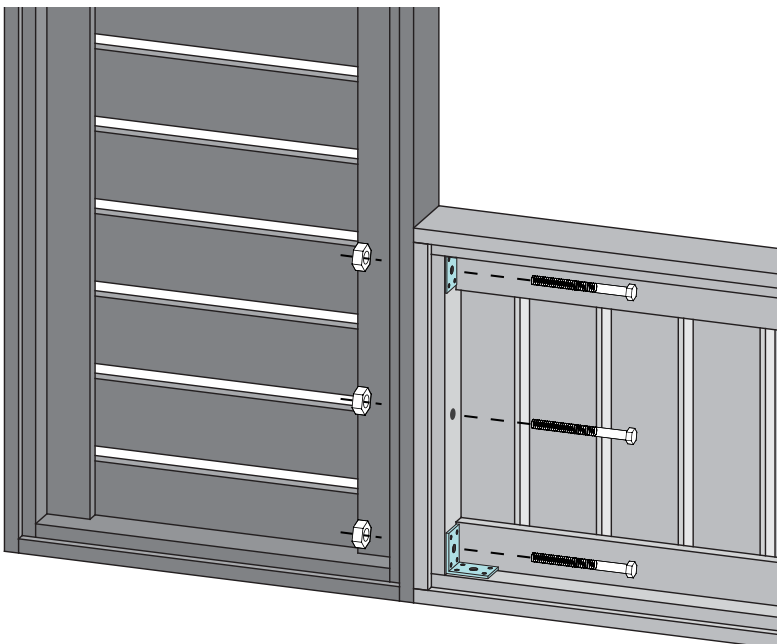
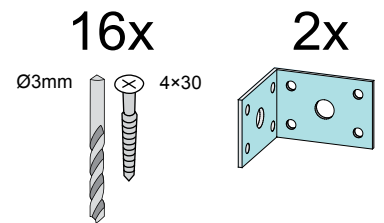
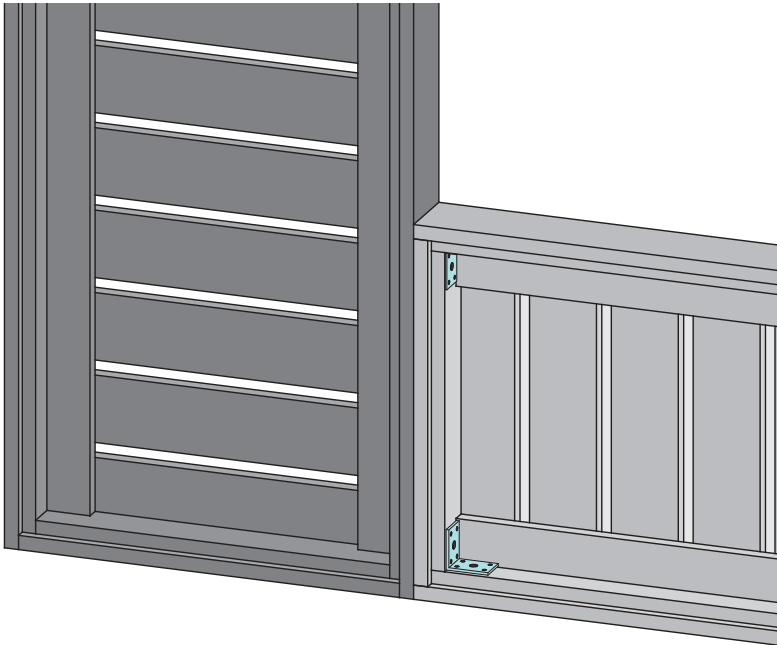

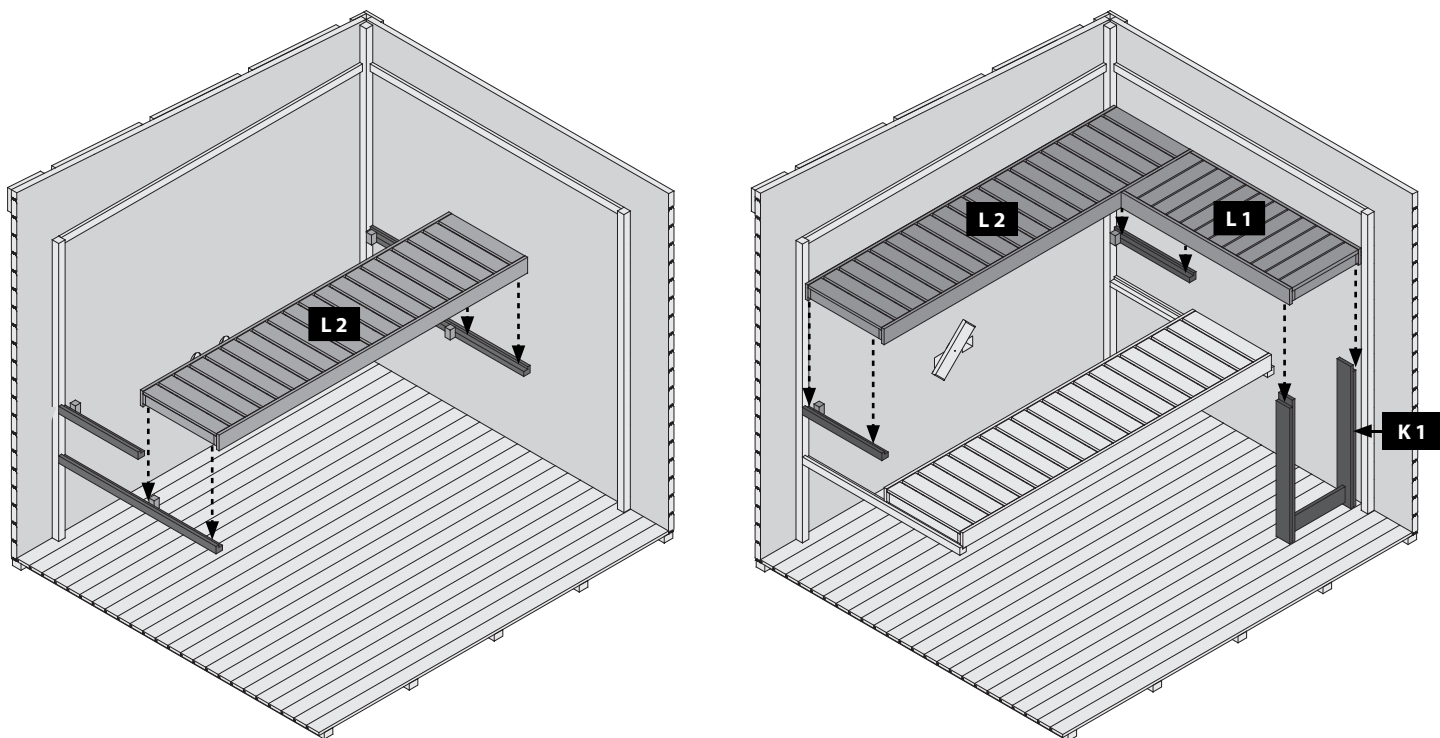

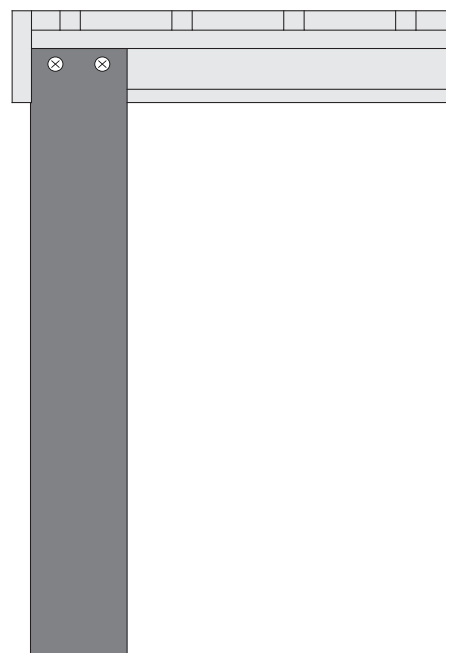
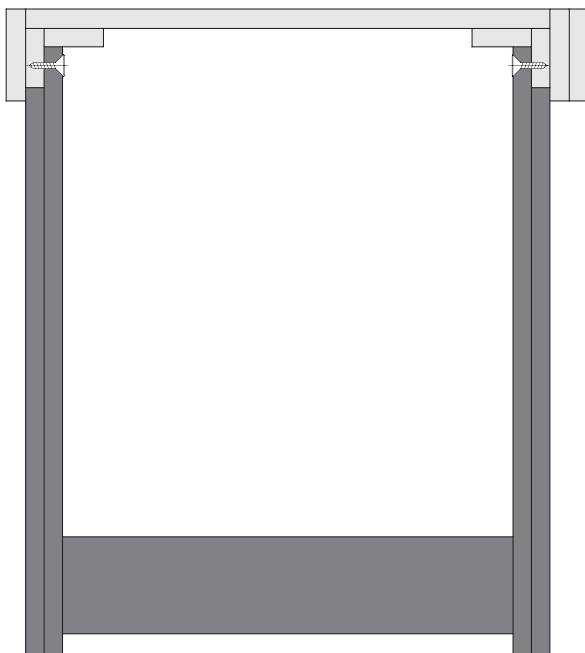
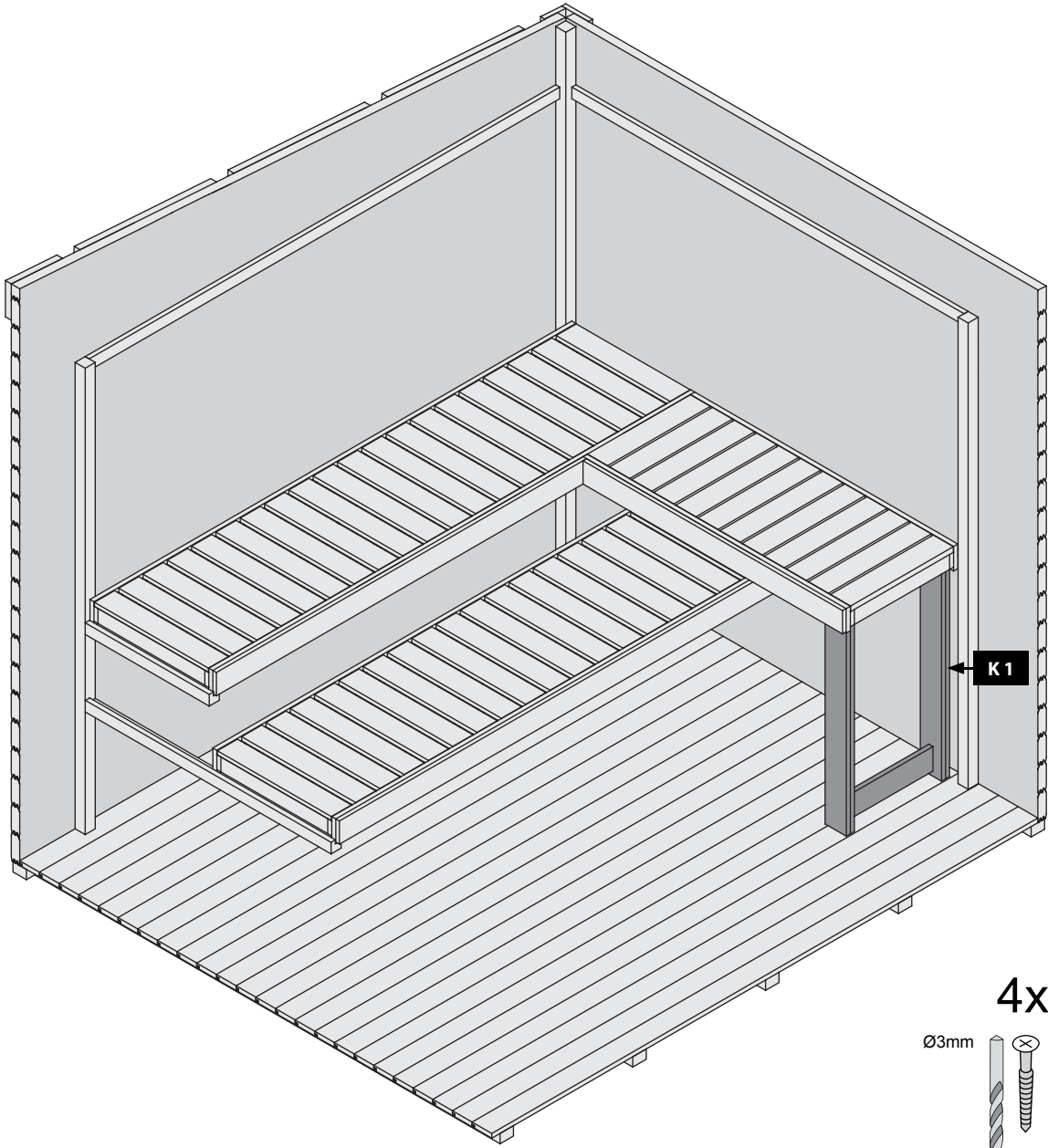



36x

Ø4 mm 4,5x30

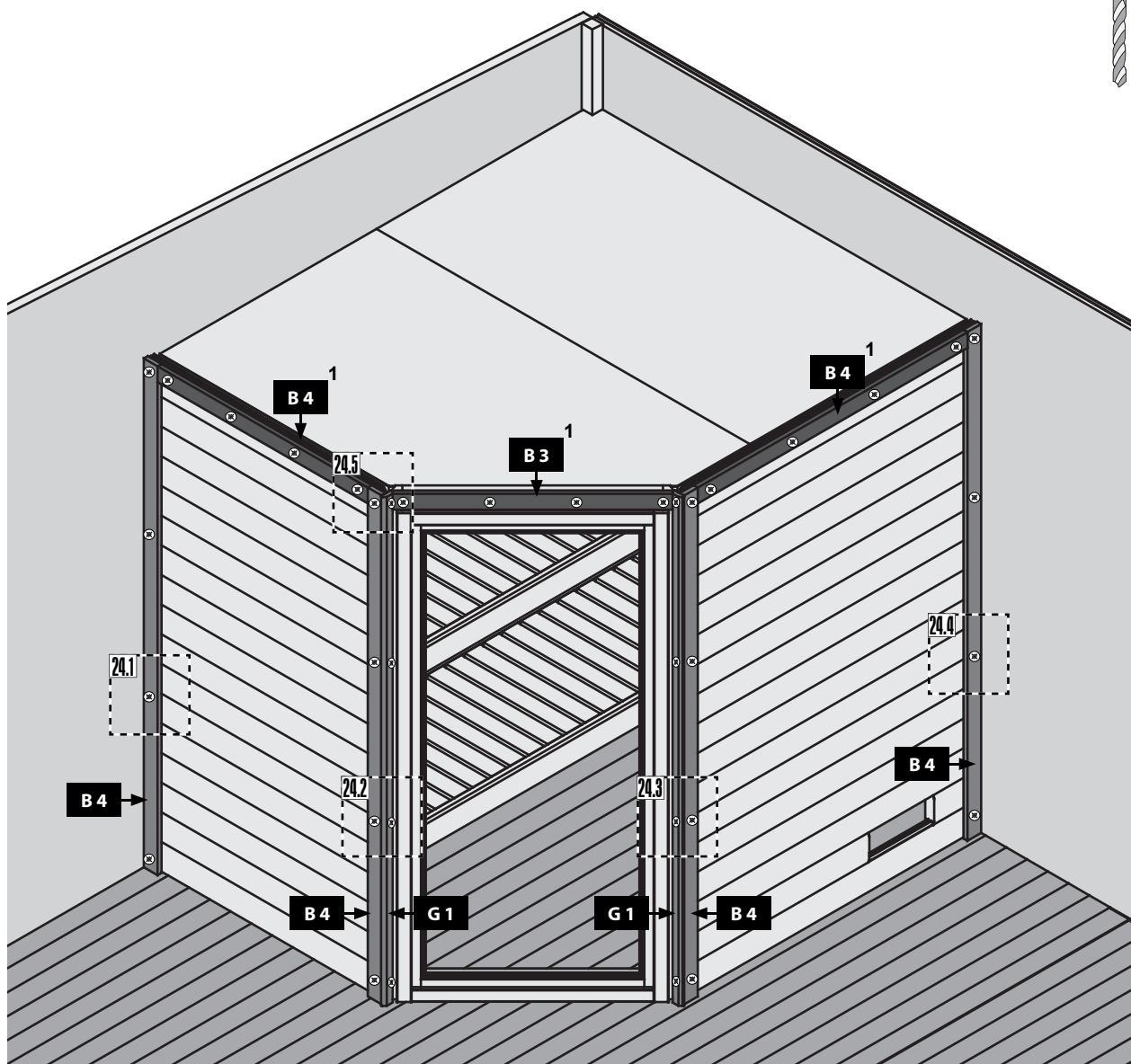
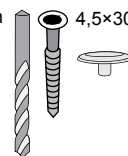

23.1

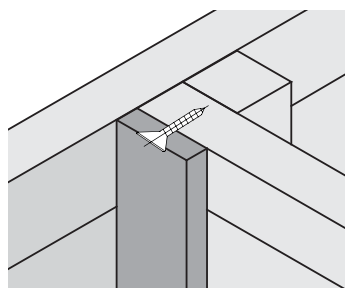

23.3

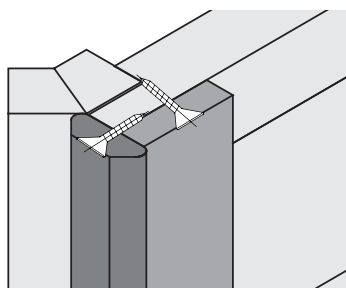

23.5



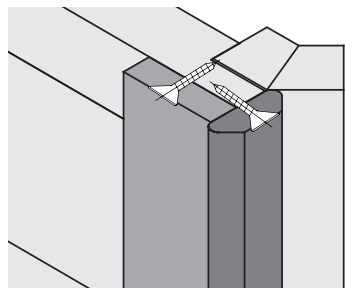

-  Bündig!
-  Flush!
-  Affleurement!
-  Gelijk!
-  I flugt!
-  Aras!
-  Combacia!
-  Stejný !



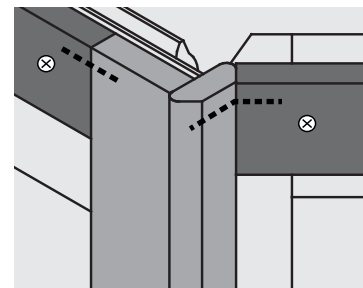
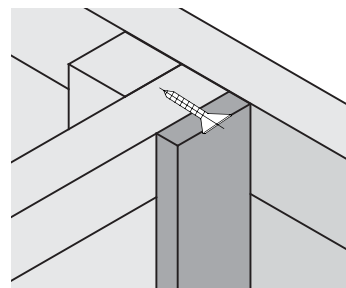

23.2



23.4



-  Einbau Glastür
-  Installation of glass door
-  Montage porte en verre
-  Montage van de glazen deur

-  Installationsglasdør
-  Montaje de la puerta de cristal
-  Installazione portello di vetro
-  Sauna Instalace dveře

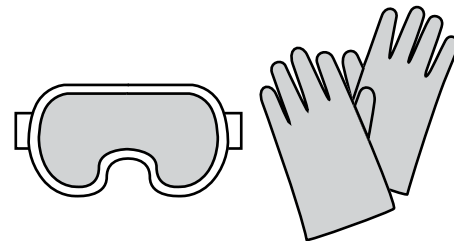

24

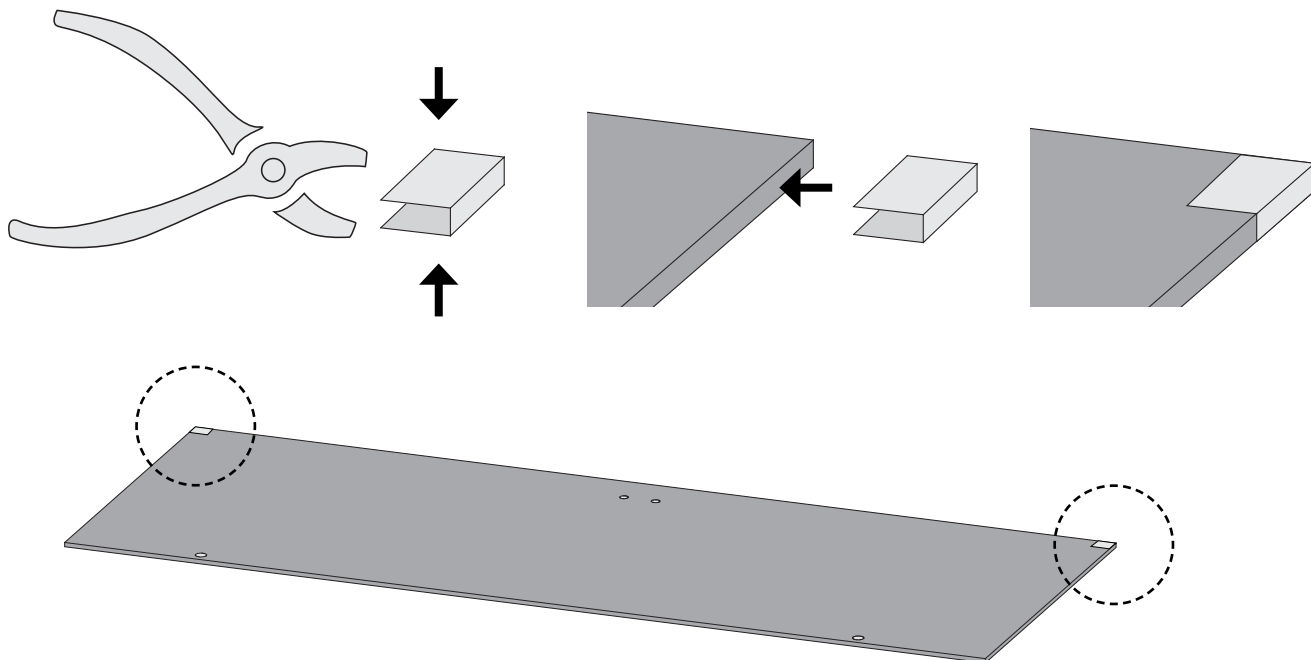



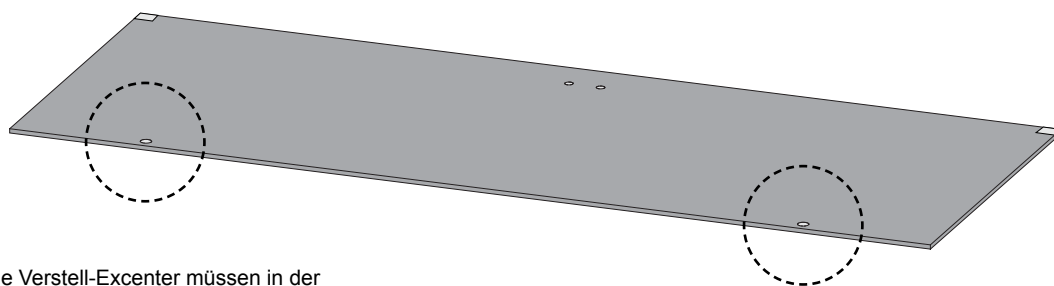



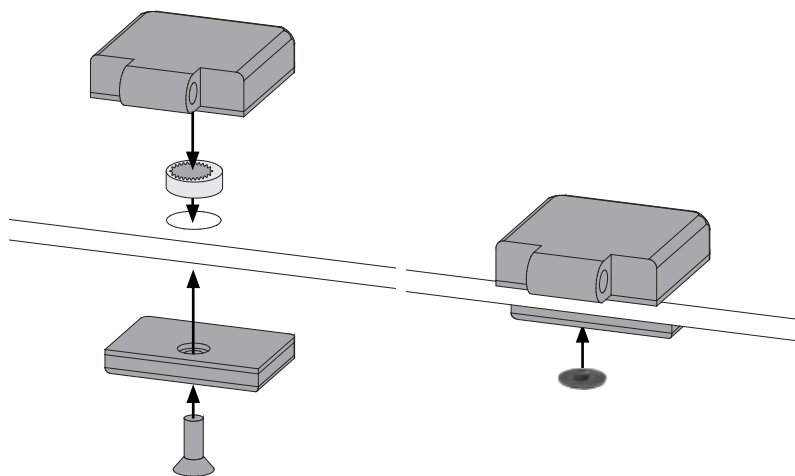

25







-  Alle Verstell-Excenter müssen in der Glasscheibe die gleiche Grundstellung haben
-  All adjustable eccentrics must have the same basic adjustment in the glass panel
-  Tous les excentreurs de positionnement doivent avoir la même position de base dans la vitre
-  Alle excentrische verstelelementen moeten in dezelfde stand in de glasplaat worden geplaatst
-  Alle justeringsexcenterer skal have samme grundlæggende position i glasruden
-  Todos los excéntricos regulables tienen que tener la misma posición base en la hoja de cristal
-  Tutti gli eccentrici di regolazione devono avere la stessa posizione base nella lastra di vetro
-  šechny nastavovací podivínů musí mít stejný základní polohy ve skle



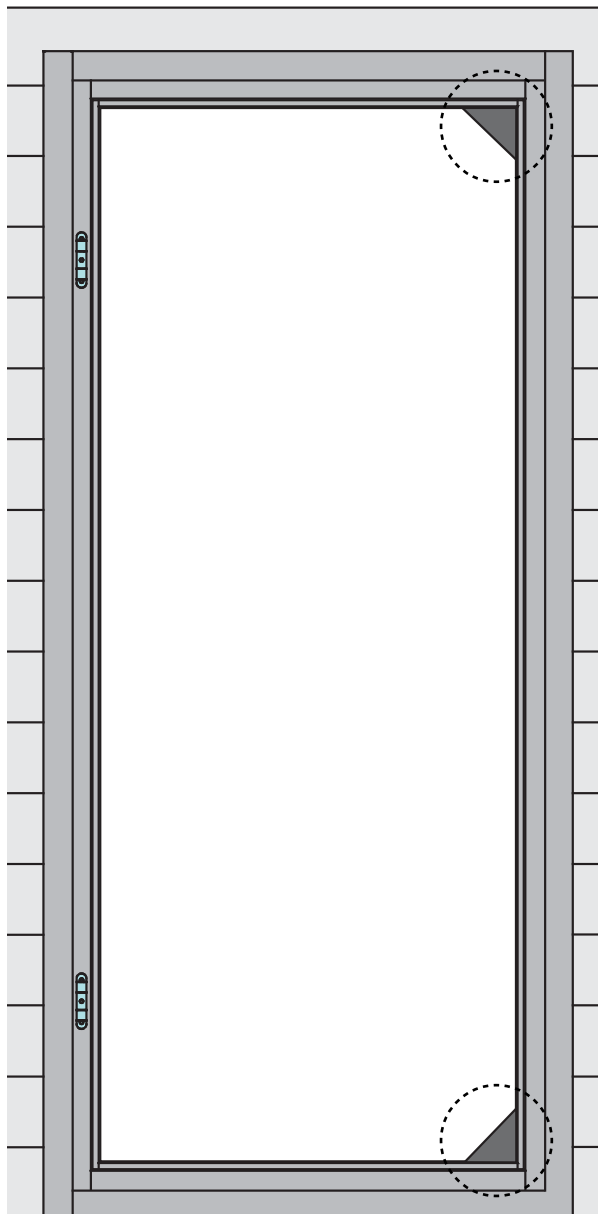
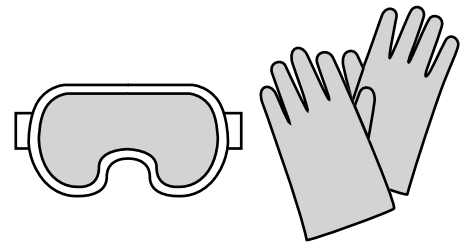



-  Einbau Glastür
-  Installation of glass door
-  Montage porte en verre
-  Montage van de glazen deur





-  Installationsglasdør
-  Montaje de la puerta de cristal
-  Installazione portello di vetro
-  Sauna Instalace dveře



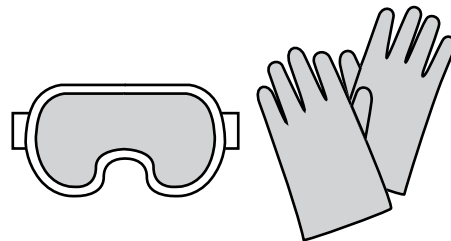



-  Einbau Glastür
-  Installation of glass door
-  Montage porte en verre
-  Montage van de glazen deur

-  Installationsglasdør
-  Montaje de la puerta de cristal
-  Installazione portello di vetro
-  Sauna Instalace dveře



-  Alle Verstell-Excenter müssen in der Glasscheibe die gleiche Grundstellung haben
-  All adjustable eccentrics must have the same basic adjustment in the glass panel
-  Tous les excentreurs de positionnement doivent avoir la même position de base dans la vitre
-  Alle excentrische verstelelementen moeten in dezelfde stand in de glasplaat worden geplaatst

-  Alle justeringsexcentricer skal have samme grundlæggende position i glasruden
-  Todos los excéntricos regulables tienen que tener la misma posición base en la hoja de cristal
-  Tutti gli eccentrici di regolazione devono avere la stessa posizione base nella lastra di vetro
-  Šechny nastavovací podivínů musí mít stejný základní polohy ve skle

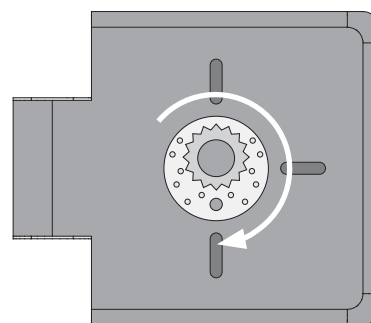
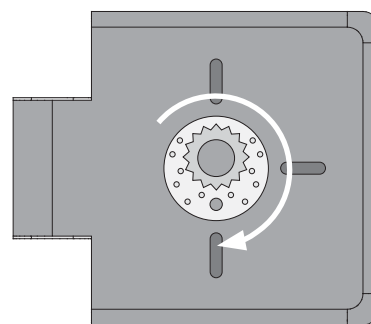
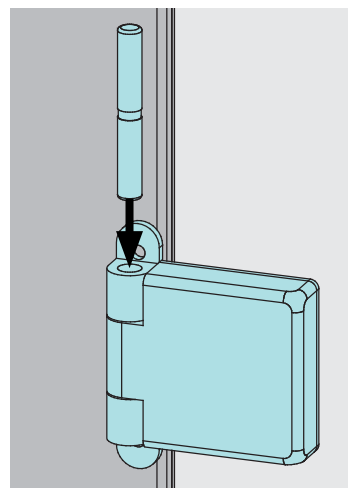
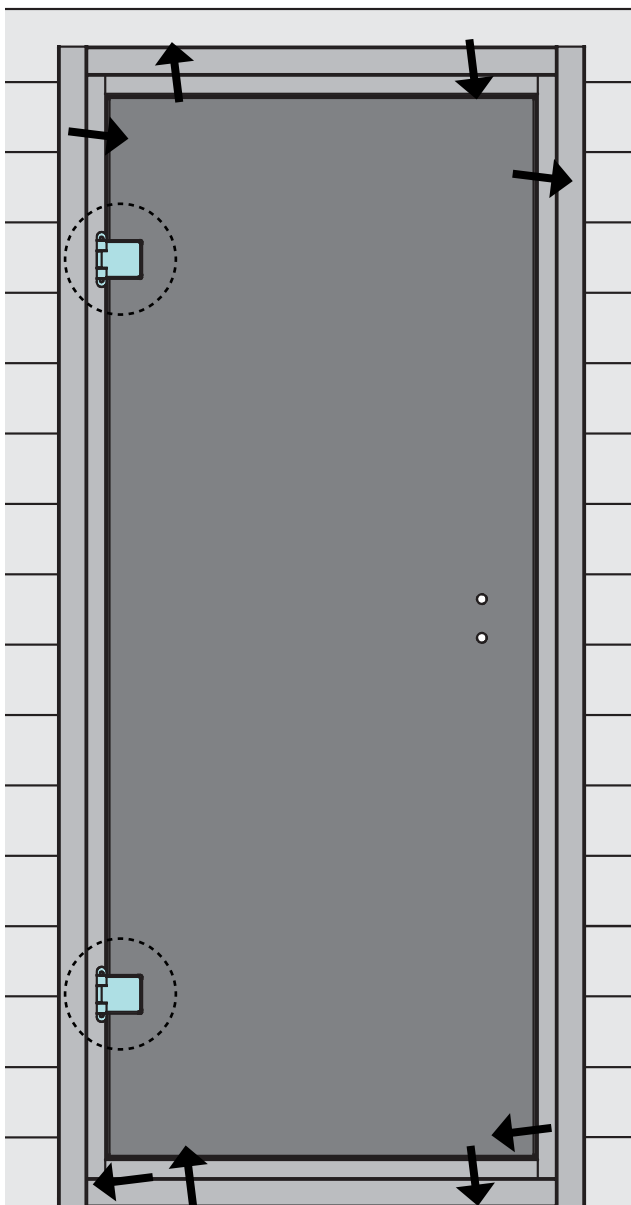



1.

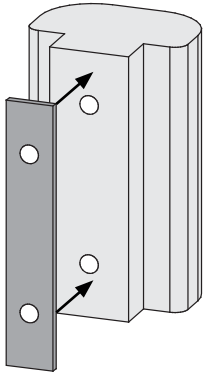

2.

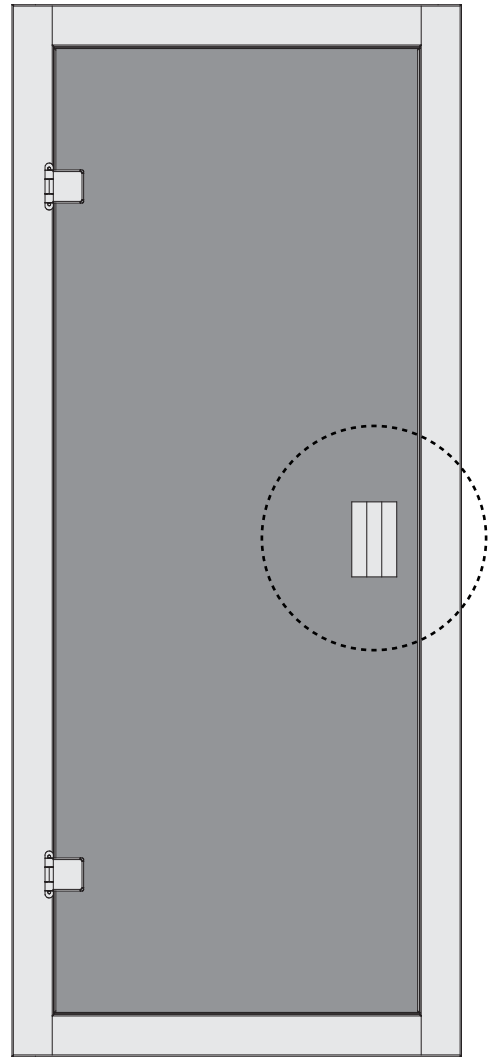
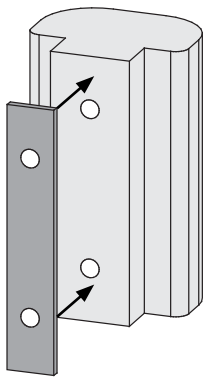

3.

