

# Montageanleitung | Instructions de montage Assembly Instructions | Instrucciones de montaje

SKU NUMBER: WF313982+WF313983

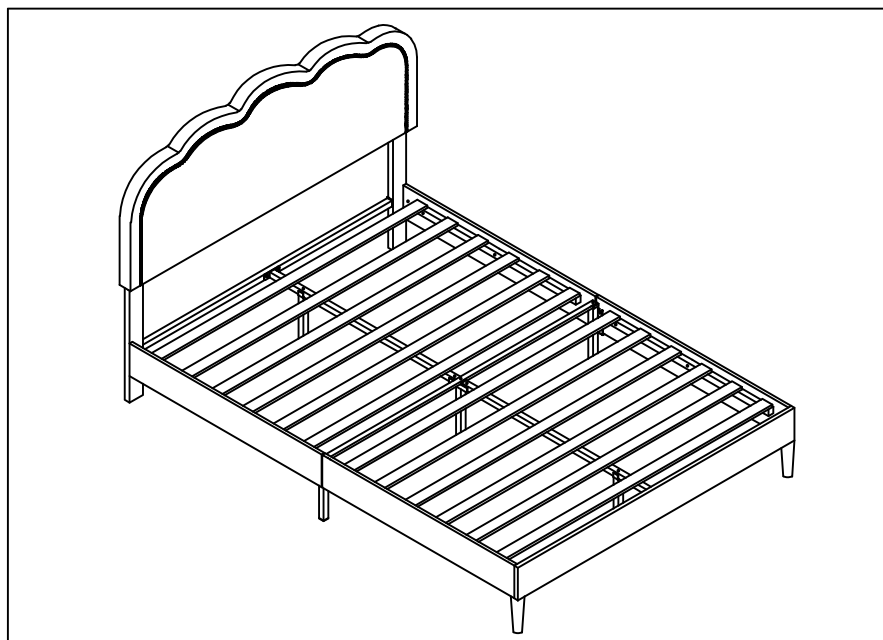

**GB** This set comes in 2 boxes. If you do not receive a full set of 2 boxes, please contact our customer service.

**DE** Dieses Set wird in 2 Schachteln geliefert. Wenn Sie nicht ein komplettes Set von 2 Boxen erhalten, kontaktieren Sie bitte unseren Kundenservice.

**FR** Ce set est livré en 2 boîtes. Si vous ne recevez pas un jeu complet de 2 boîtes, veuillez contacter notre service clientèle.



English

IMPORTANT ! KEEP FOR FUTURE REFERENCE : READ CAREFULLY

- To be assembled by an adult. Assembly must be checked by an adult before use
- WARNING ! Keep all screws, small parts and plastic bags out of the reach of children
- Properly identify all parts before assembling
- Never use your item if any of its parts are broken or missing
- Should any problems arise, please contact our After Sales Service
- Manufacturer's instructions shall be followed at all times
- Care: Clean with a soft, dry cloth. In case of larger stains, carefully rub with a slightly damp, non-abrasive sponge
- Do not jump on the bed

Français

IMPORTANT ! CONSERVER POUR RÉFÉRENCE ULTÉRIEURE : LIRE ATTENTIVEMENT

- Le montage doit être effectué par un adulte. Le montage doit être vérifié par un adulte avant utilisation
- ATTENTION ! Tenir les vis, les petites pièces et les sachets en plastique hors de portée des enfants
- Identifiez correctement toutes les pièces avant de les assembler
- N'utilisez jamais votre article si l'une de ses pièces est cassée ou manquante
- En cas de problème, veuillez contacter notre service après-vente
- Les instructions du fabricant doivent être respectées à tout moment
- Entretien : nettoyer avec un chiffon doux et sec. En cas de taches plus importantes, frotter soigneusement avec une éponge non abrasive légèrement humide. légèrement humide et non abrasive
- Ne pas sauter sur le lit

Deutsch

WICHTIG ! ZUM SPÄTEREN NACHSCHLAGEN AUFBEWAHREN: SORGFÄLTIG LESEN

- Muss von einem Erwachsenen zusammengebaut werden. Der Zusammenbau muss vor dem Gebrauch von einem Erwachsenen überprüft werden
- WARNUNG! Bewahren Sie alle Schrauben, Kleinteile und Plastikbeutel außerhalb der Reichweite von Kindern auf
- Kennzeichnen Sie vor dem Zusammenbau alle Teile richtig.
- Benutzen Sie Ihren Artikel niemals, wenn Teile gebrochen sind oder fehlen
- Sollten Probleme auftreten, wenden Sie sich bitte an unseren Kundendienst
- Die Anweisungen des Herstellers sind stets zu befolgen
- Pflege: Mit einem weichen, trockenen Tuch reinigen. Bei größeren Flecken vorsichtig mit einem leicht feuchten, nicht scheuernden Schwamm abreiben. nicht scheuernden Schwamm
- Nicht auf das Bett springen

Italiano

**IMPORTANTE! CONSERVARE PER RIFERIMENTO FUTURO: LEGGERE ATTENTAMENTE**

- Deve essere assemblato da un adulto. L'assemblaggio deve essere controllato da un adulto prima dell'uso
- **ATTENZIONE!** Tenere tutte le viti, le piccole parti e i sacchetti di plastica fuori dalla portata dei bambini
- Identificare correttamente tutte le parti prima dell'assemblaggio
- Non utilizzare mai l'articolo se alcune parti sono rotte o mancanti
- In caso di problemi, si prega di contattare il nostro Servizio Post Vendita
- Le istruzioni del produttore devono essere sempre seguite
- Cura: Pulire con un panno morbido e asciutto. In caso di macchie più estese, strofinare accuratamente con una spugna leggermente umida e nonspugna leggermente umida e non abrasiva
- Evitare il rischio di incendio, non collocando i mobili vicino a fonti di accensione o a oggetti caldi
- Non saltare sul letto

Español

**¡ IMPORTANTE ! CONSERVELO PARA FUTURAS CONSULTAS: LEA ATENTAMENTE**

- Debe ser montado por un adulto. El montaje debe ser comprobado por un adulto antes del uso
- **ADVERTENCIA** Mantenga todos los tornillos, piezas pequeñas y bolsas de plástico fuera del alcance de los niños.
- Identifique correctamente todas las piezas antes de montarlas
- Nunca utilice su artículo si alguna de sus piezas está rota o falta
- Si surge algún problema, póngase en contacto con nuestro Servicio Postventa
- Las instrucciones del fabricante deben seguirse en todo momento
- Cuidado: Limpiar con un paño suave y seco. En caso de manchas más grandes, frote cuidadosamente con una esponja no abrasiva ligeramente humedecida.
- Evite el riesgo de incendio no colocando los muebles cerca de fuentes de ignición u objetos calientes.
- No saltar sobre la cama.

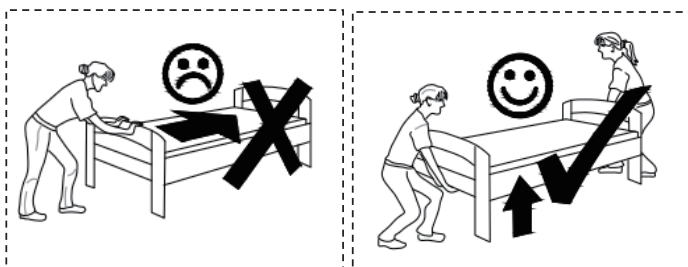

3 / 18

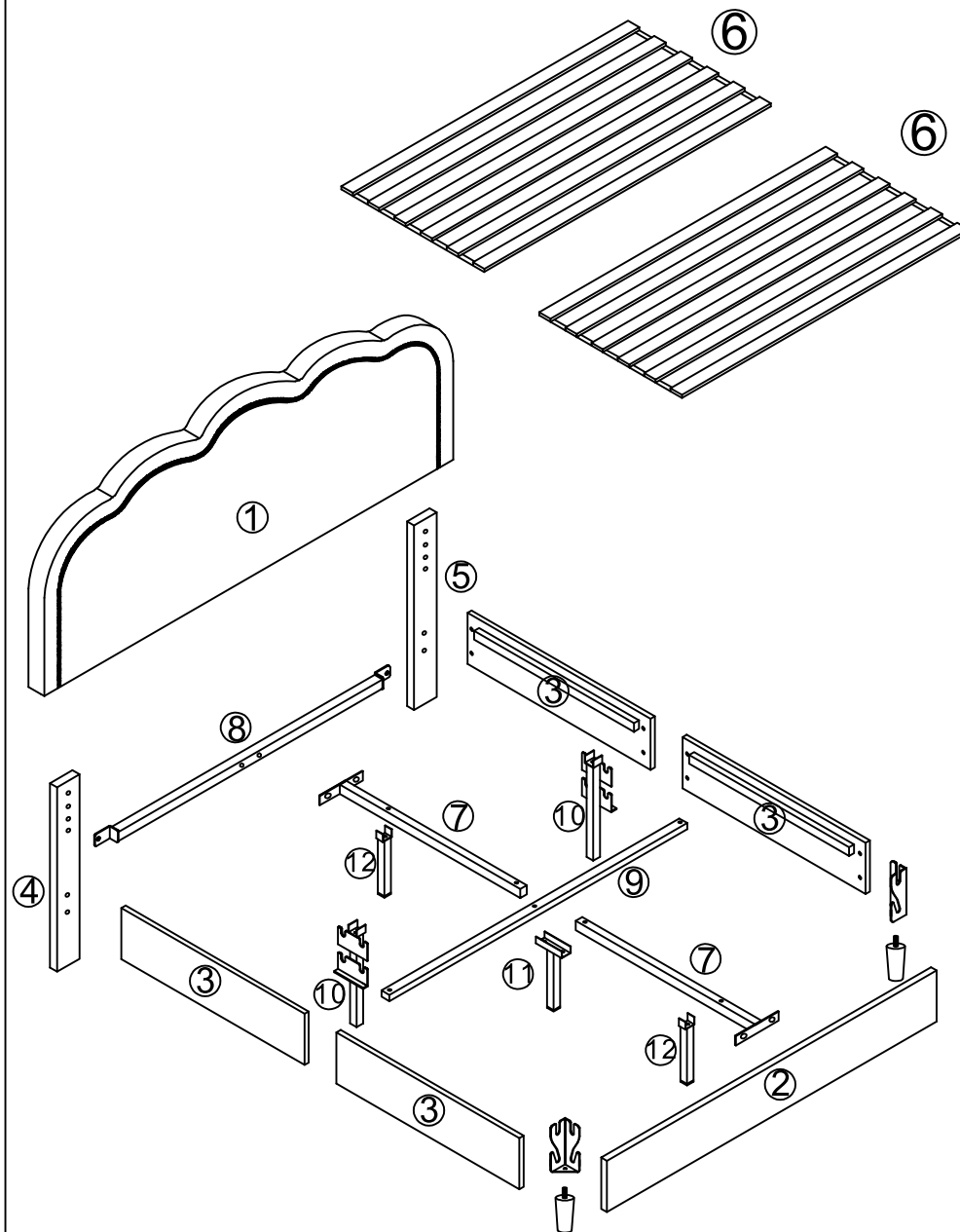





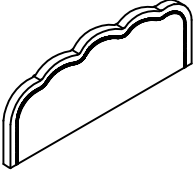
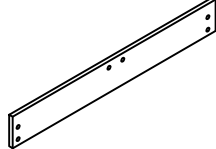
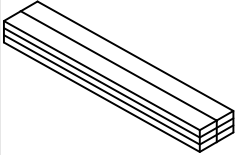
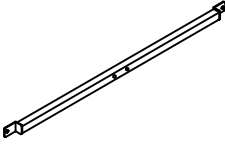
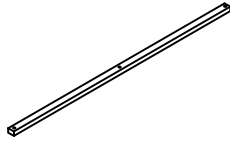

4 / 18

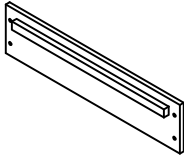
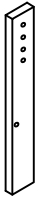
# WF313982

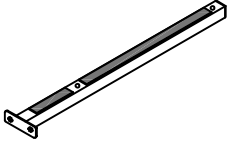

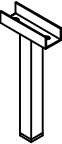







①		1pc	②		1pc
⑥		2sets	⑧		1pc
⑨		1pc			

# WF313983

③		4pcs	④		1pc
⑤		1pc	⑦		2pcs
⑩		2pcs	⑪		1pc
⑫		2pcs			

# Hardware List-Hardware-Liste-Liste du matériel

## WF313983

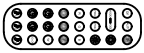
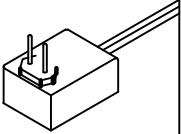
Ⓐ	 M8 x 18	24	Ⓑ	 M8 x 25	8
Ⓒ	 M8 x 45	9	Ⓓ		4
Ⓔ	 M5	1	Ⓕ		2
Ⓖ	 Angle iron (Left)	1	Ⓖ	 Angle iron (Right)	1
Ⓘ		2	Ⓙ	 	1
Ⓚ		1			

7 / 18

1	 M8*25 B*2PCS	 M8*45 C*4PCS	 D*4PCS	 E*1PC
---	---	---	--	---

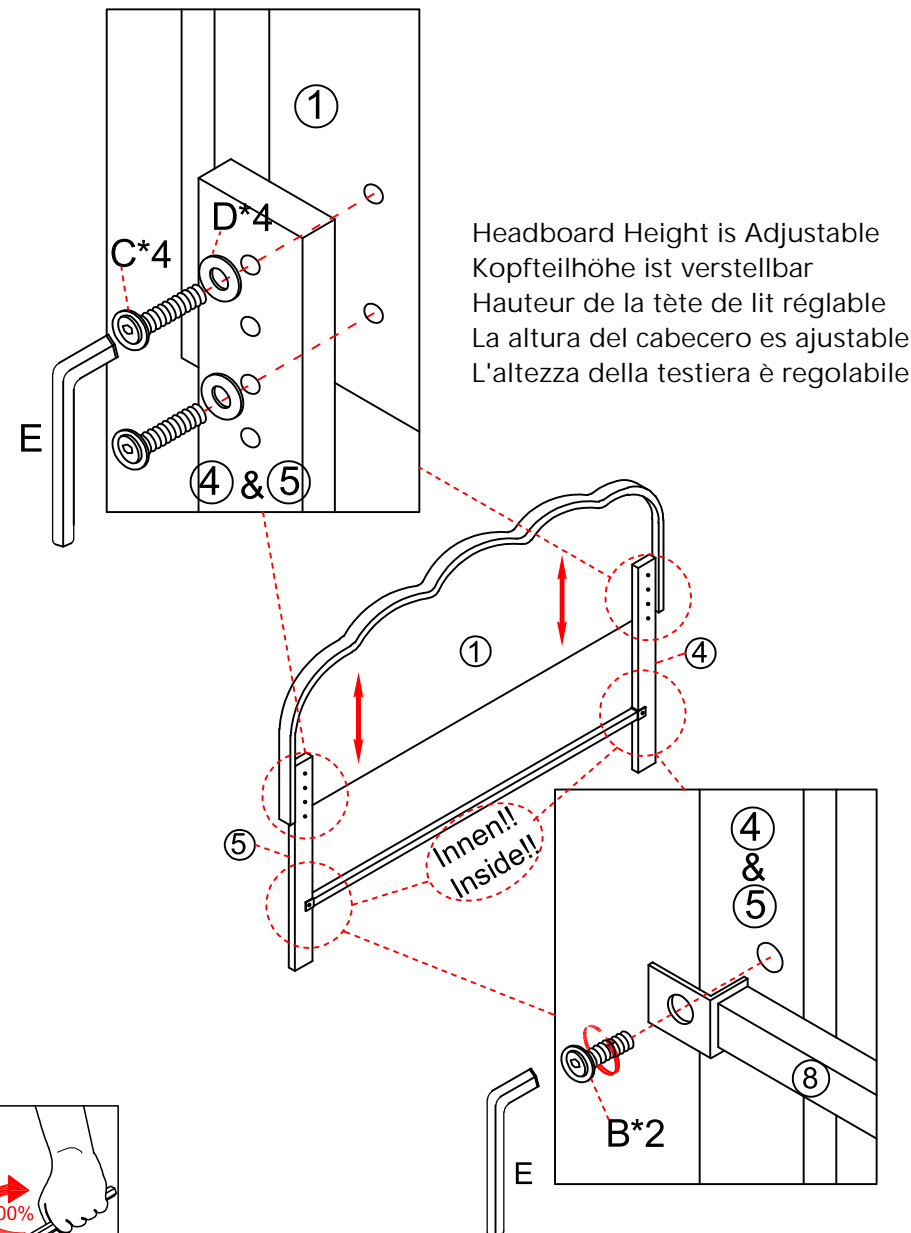

8 / 18

2

G\*1PC

H\*1PC

M8\*18  
A\*4PCS

E\*1PC

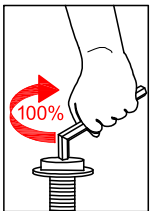
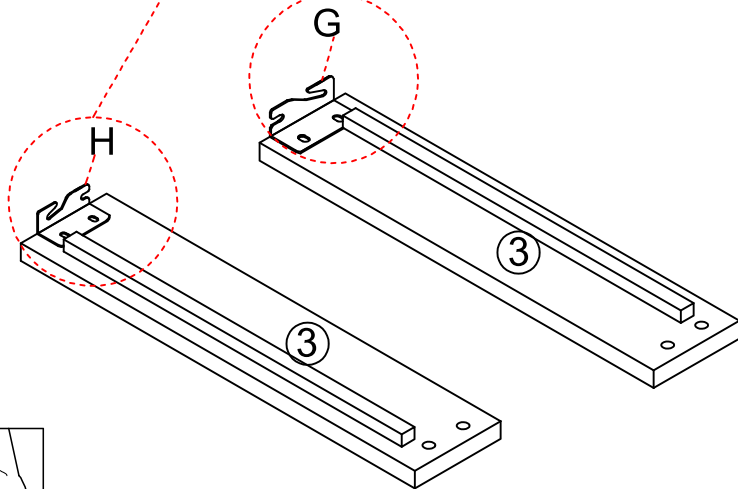
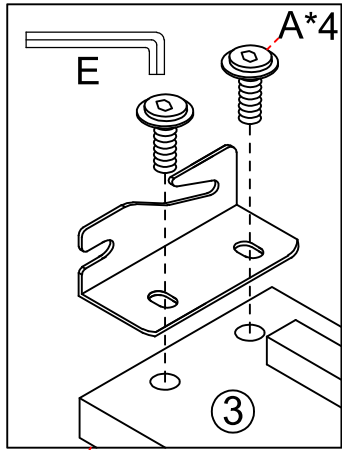

9 / 18

3

M8\*18  
A\*8PCS

E\*1PC

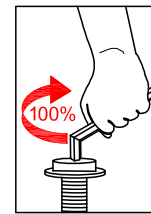
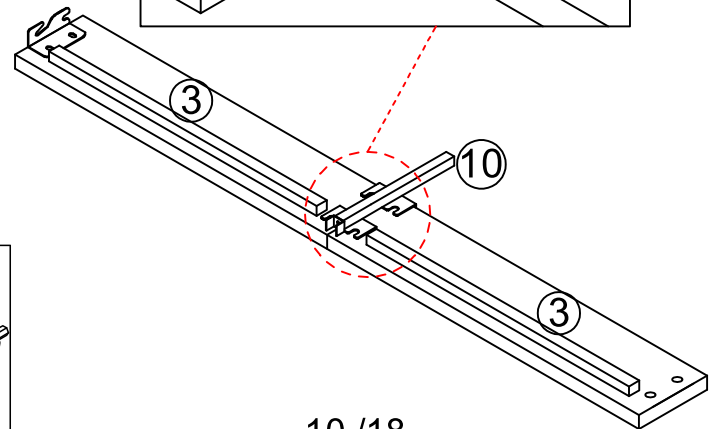
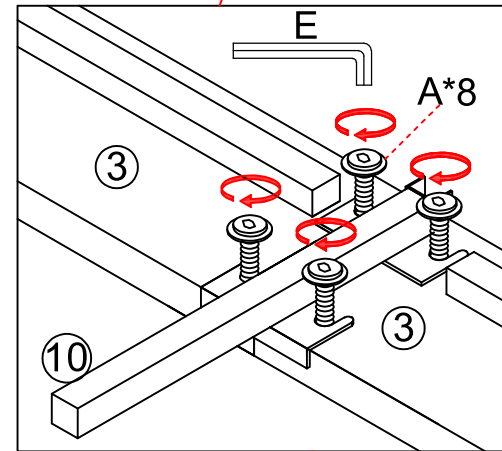
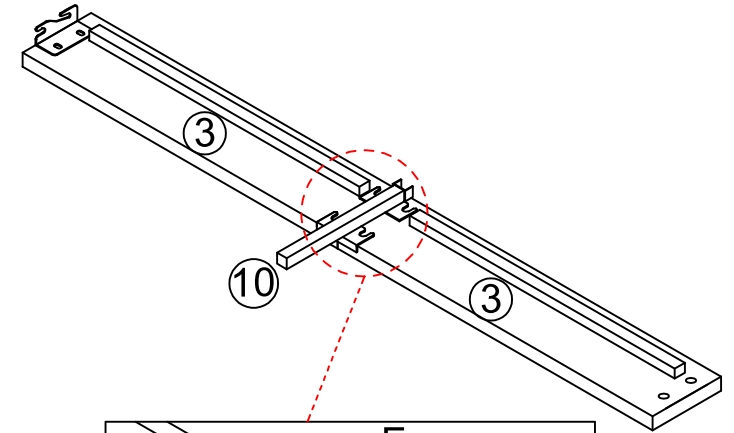

10 / 18

4



F\*2PCS



I\*2PCS

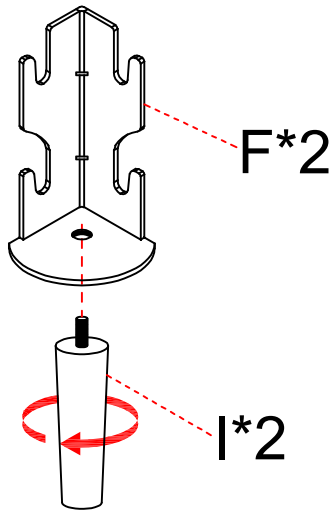

11 / 18

5

M8\*25  
B\*4PCS

E\*1PC

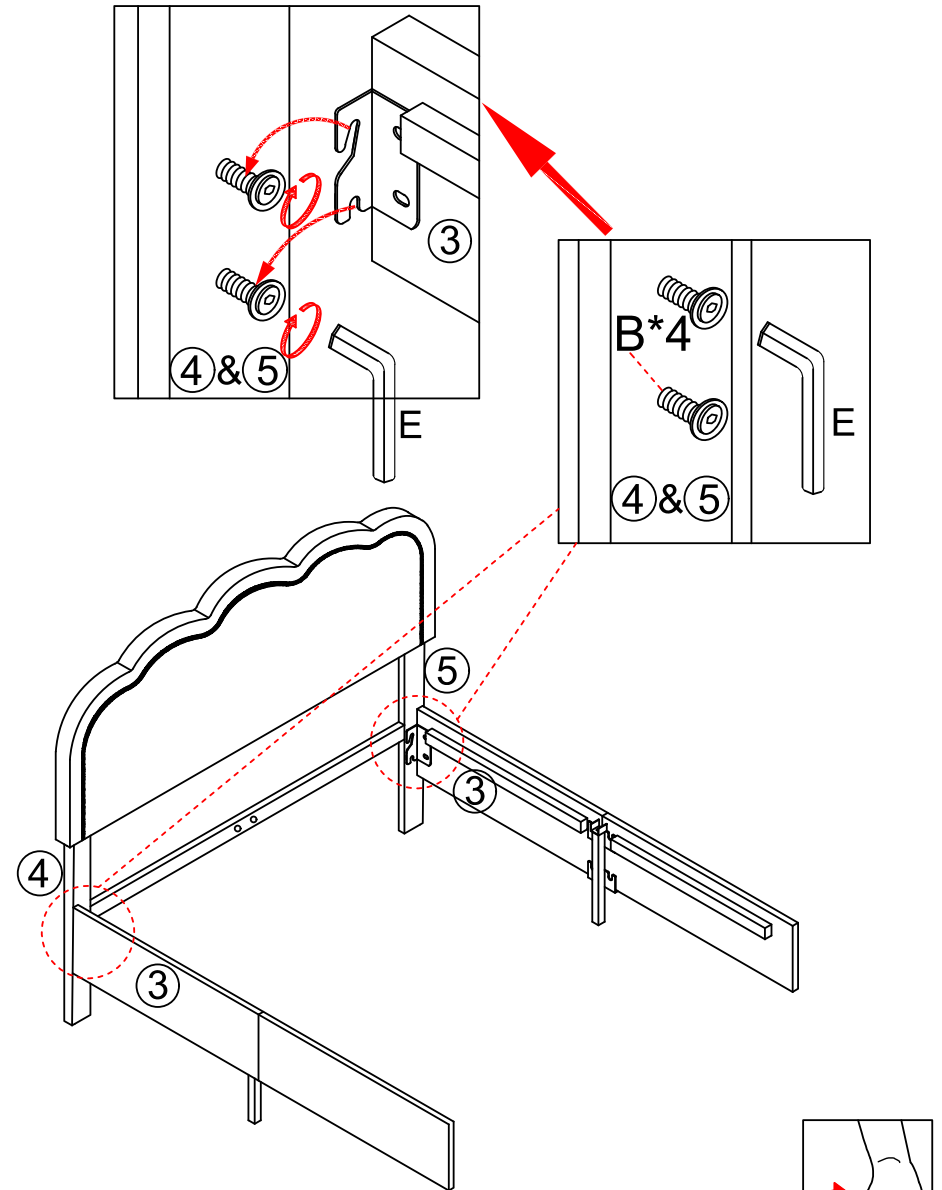

12 / 18

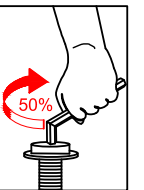

6 M8\*18 A\*8PCS E\*1PC

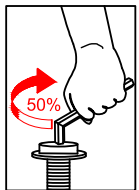
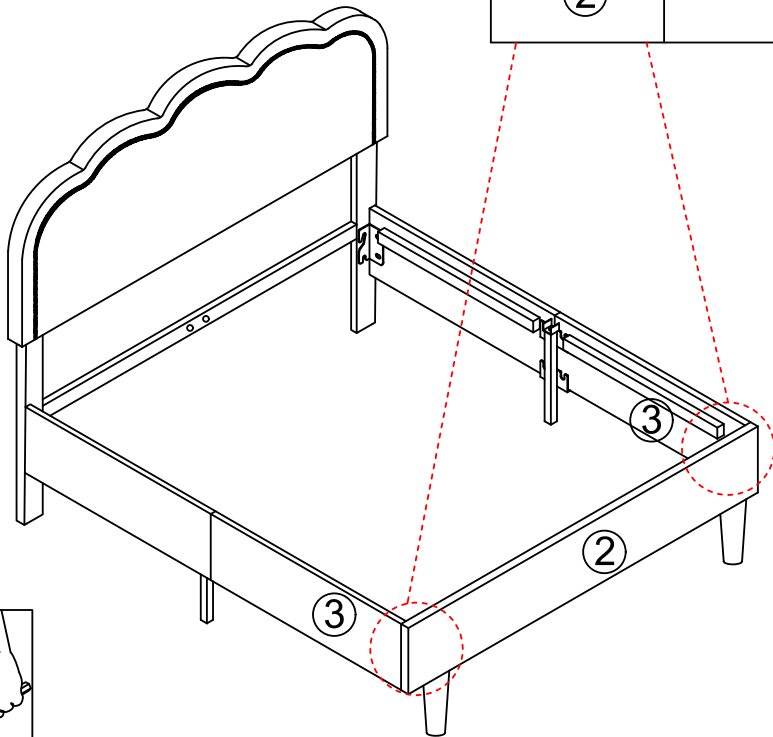
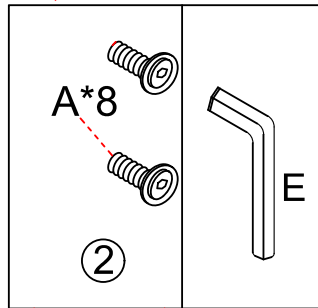
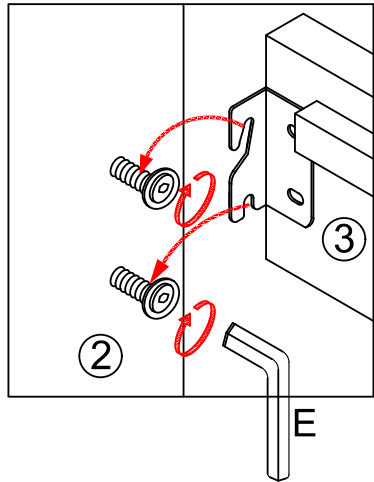

13 / 18

7 M8\*18 A\*4PCS M8\*25 B\*2PCS M8\*45 C\*2PCS E\*1PC

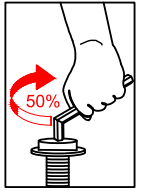
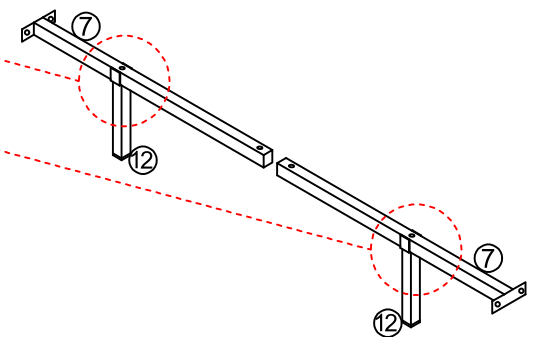
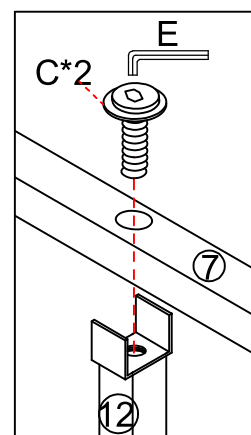
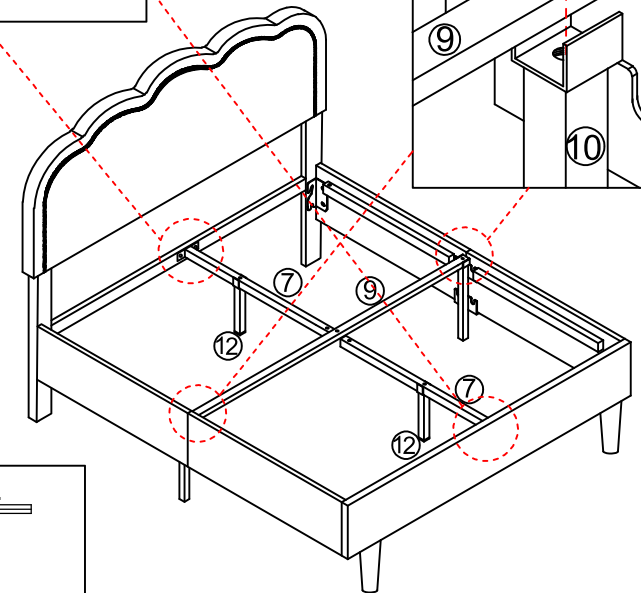
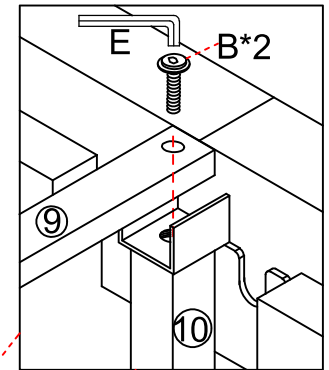
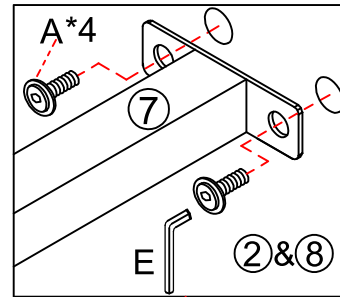

14 / 18

8

M8\*45  
C\*3PCS E\*1PC

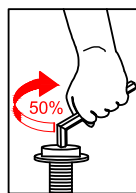
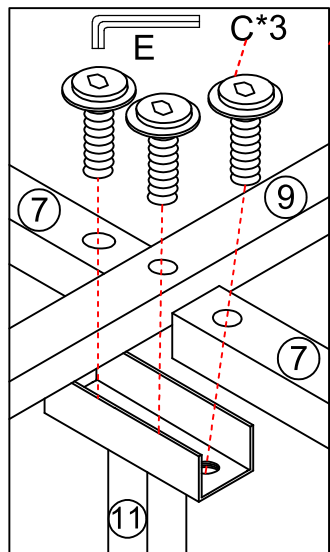
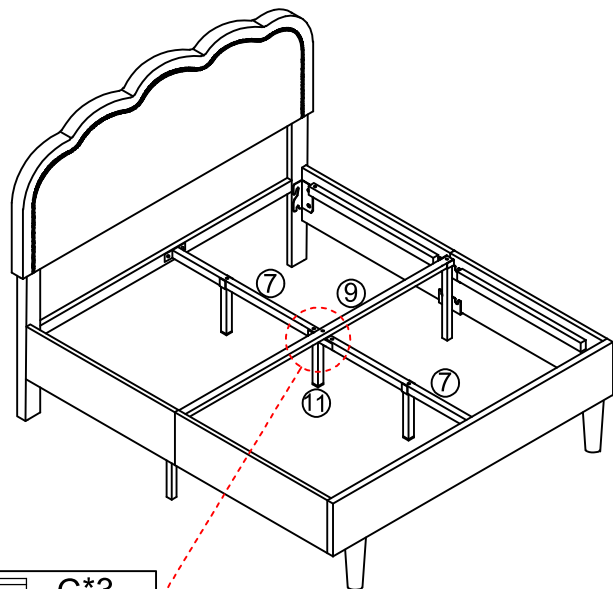

15 / 18

9

K\*1PC J\*1PC

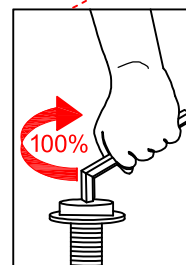
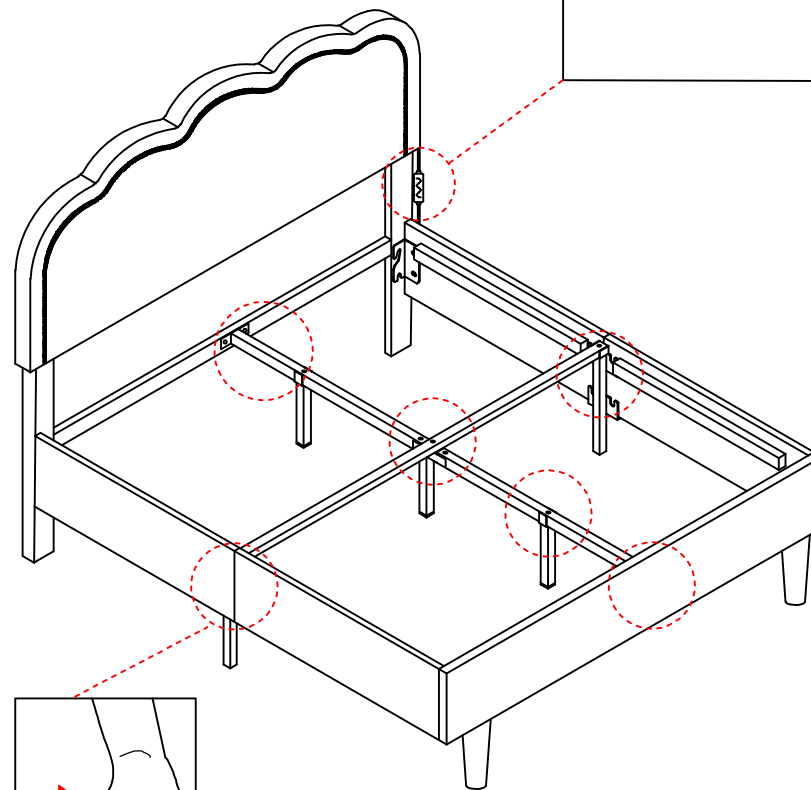
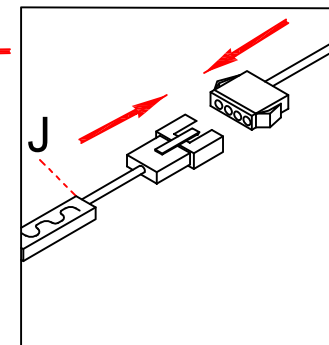
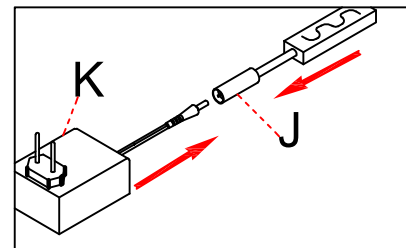

16 / 18



10

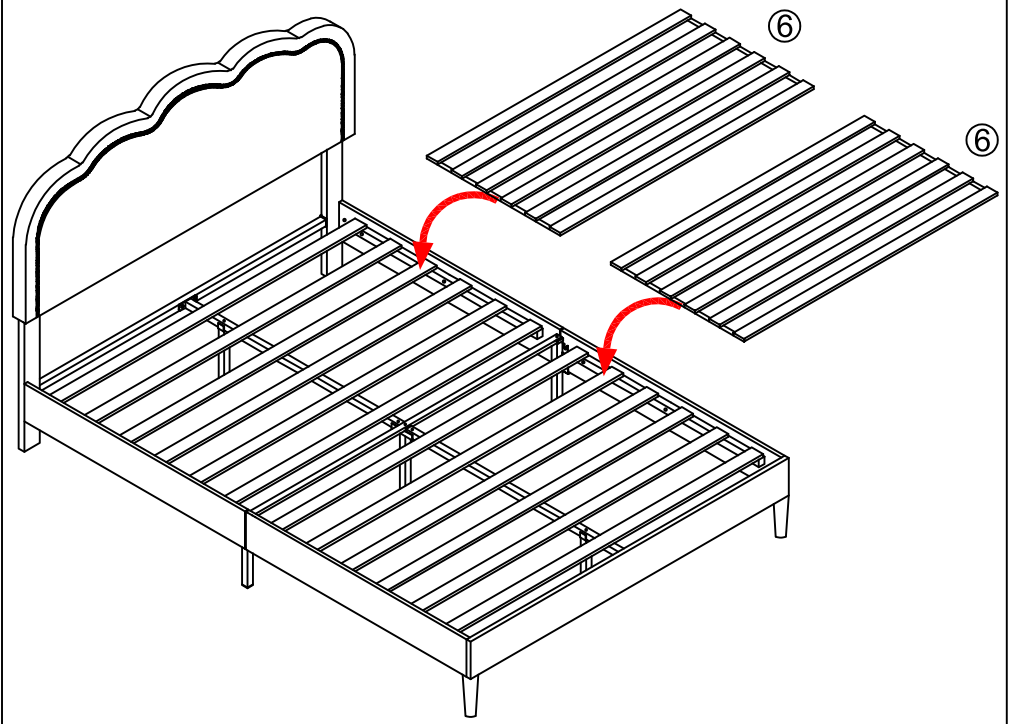

17 / 18

11

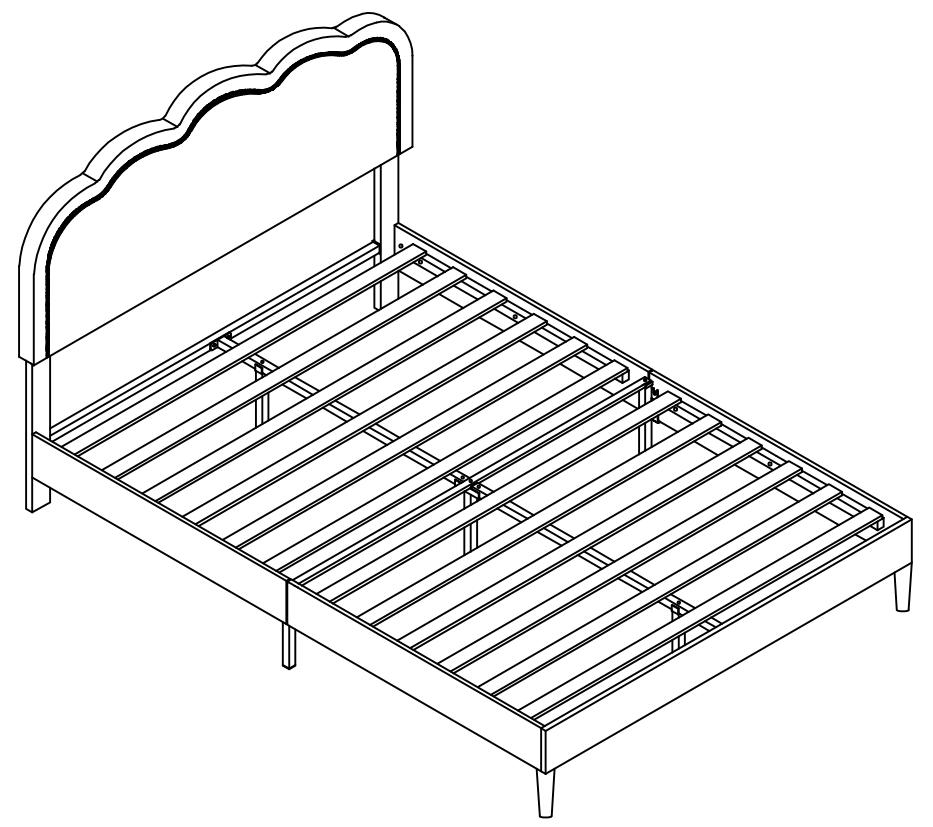

18 / 18



**NOTICE:**

You can scan the QR code here and download an app that can control the color of the light strip like a remote control. When your phone plays music through the app, the color of the light strip will also change according to the strength of the music.

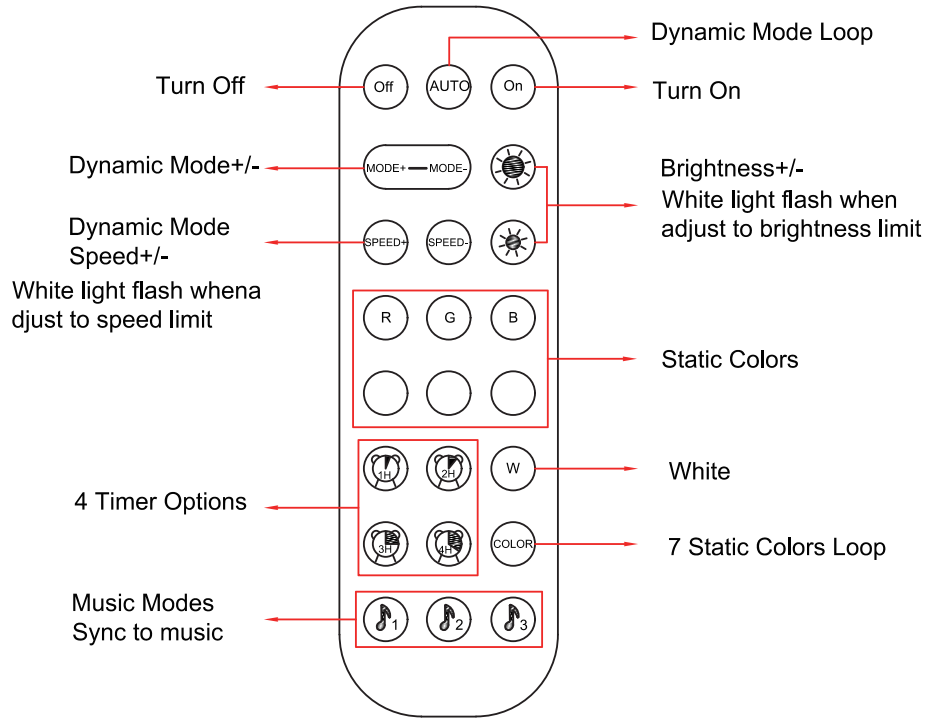

**Notices**

1. Please pull out the battery insulated plastic chip before using remote.
2. Press the lock key, the remote keys will be locked, press the lock key again, all the remote keys will be unlocked.

- GB** - NOTE: The battery in the remote control requires you to purchase and install it yourself. Model: CR2025 3.V
- DE** - HINWEIS: Die Batterie in der Fernbedienung müssen Sie selbst kaufen und installieren. Modell: CR2025 3.V
- FR** - REMARQUE : la pile de la télécommande doit être achetée et installée par vos soins. Modèle : CR2025 3.V
- IT** - NOTA: la batteria del telecomando deve essere acquistata e installata autonomamente. Modello: CR2025 3.V
- ES** - NOTA: La pila del mando a distancia debe comprarla e instalarla usted mismo. Modelo CR2025 3.V

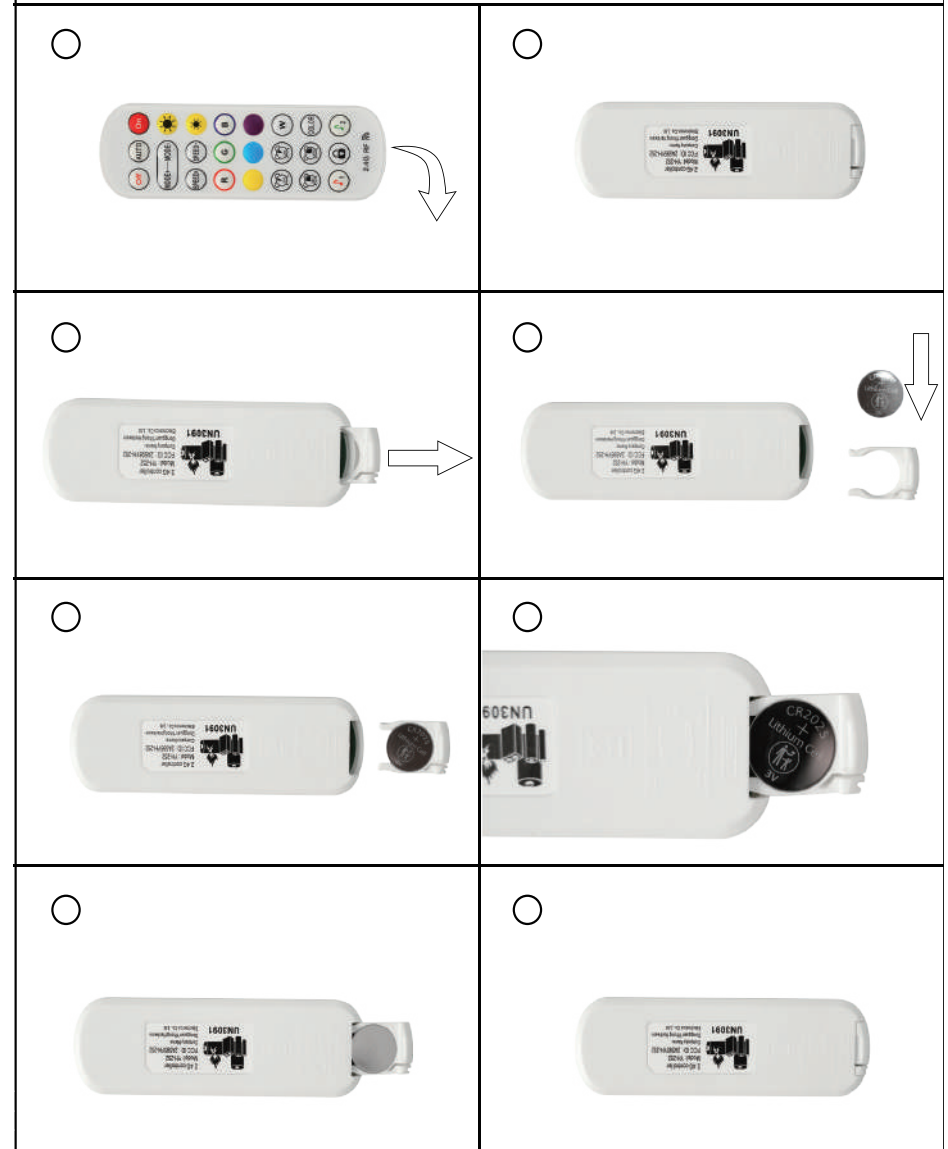

# Certificate of Compliance

**Certificate No. :** LST200668061E  
**Applicant :** Shenzhen Pinchengxin Technology Co., Ltd.  
**Applicant Address :** 203, Floor 2, Building A, Electric Power Plant, No.1, Yonghe Road, Longteng Community, Shiyan Street, Bao'an District, Shenzhen  
**Manufacturer :** Shenzhen Pinchengxin Technology Co., Ltd.  
**Manufacturer Address :** 203, Floor 2, Building A, Electric Power Plant, No.1, Yonghe Road, Longteng Community, Shiyan Street, Bao'an District, Shenzhen  
**Product :** LED Strip Light  
**M/N :** 5050  
**3528, 2835, 3014, 2216, 335, 2210, 5630, 5730, 0805, 0603**  
**Trademark :** N/A  
**Test Standard :** EN 55015:2013+A1:2015  
 EN 61000-3-2:2014, EN 61000-3-3:2013  
 EN 61547:2009  
 EN 61000-4-2:2009, EN 61000-4-3:2006+A1:2008+A2:2010,  
 EN 61000-4-4:2012, EN 61000-4-5:2014+A1:2017,  
 EN 61000-4-6:2014, EN 61000-4-8:2010, EN 61000-4-11:2004+A1:2017

The EUT described above has been tested by us with the listed standards and found in compliance with the council EMC directive 2014/30/EU. It is possible to use CE marking to demonstrate the compliance with this EMC Directive. It is only valid in connection with the test report number: LST200668061ER.



Issue Date: Jun. 28, 2020

Zertifikat

Certificate



Zertifikat Nr. / Certificate No. S 50558898	Blatt / Sheet 0001	Gültig ab / Valid from 25.10.2022 (day/mo/yr)
Ihr Zeichen / Client Reference	Unser Zeichen / Our Reference 02-Zhanmi-CN22Z7EO 001	Längstens gültig bis / Latest expiration date 24.10.2027 (day/mo/yr)

Genehmigungsinhaber / License Holder XIAMEN INVCY ELECTRONICS CO., LTD. 1F/3F-5F, BLDG 5, No.943-5, Tonglong 2nd Rd, Torch Hi-tech Industrial Zone 361000 (Xiang'an) Xiamen Fujian P.R. China	Fertigungsstätte / Manufacturing Plant Refer to latest revision of the annex list of factories
---	--

Prüfzeichen / Test Mark



Geprüft nach / Tested acc. to  
 EN 60335-1:2012+A11+A13+A14+A2+A15  
 EN 60335-2-29:2021+A1  
 EN 62233:2008  
 EK1 527-12 Rev. 2  
 EK1 557-13

Zertifiziertes Produkt (Geräteidentifikation)  
Certified Product (Product Identification)

Lizenzentgelte - Einheit  
License Fee - Unit

Ladegerät (Battery Charger)

Bezeichnung: IVPxxxx-yyyyWz IVPxxxx-yyyyAz  
 (Type Designation): IVPxxxx-yyyyBz (Invcy)

xxxx= 0370-3000; vierstellige Zahl steht für den 100 fachen Wert der Ausgangsspannung in V. Die Ausgangsspannung steigt von 3.70V in Schritten von 0.01V an. (four digits indicating 100 times the output voltage value in V. The output voltage is rising in steps of 0.01V from 3.70V.)

yyyy= 0100-2000; vierstellige Zahl steht für den 1000 fachen Zahlenwert den Ausgangsstrom in A. Der Ausgangsstrom steigt von 0.1A in Schritten von 0.01A an. (four digits indicating 1000 times the output current value in A. The output current is rising in steps of 0.01A from 0.1A.)

z = G oder (or) B

Nennspannung (Rated Voltage) : AC 100-240V; 50/60Hz  
 Nennstrom (Rated Current) : 0.5A  
 Schutzklasse (Protection Class): II  
 Fortsetzung Blatt (continued on page): 0C02

ANLAGE (Appendix): 1

Dem Zertifikat liegt unsere Prüf- und Zertifizierungsordnung zugrunde. Produkt und Fertigungsstätte erfüllen § 20 des Produktsicherheitsgesetzes.  
 This certificate is based on our Testing and Certification Regulation. The provisions of §20 Product Safety Act are complied with.

TÜV Rheinland LGA Products GmbH, Tillystraße 2, 90431 Nürnberg

<http://www.tuv.com/safety> E-mail: [markcheck@tuv.com](mailto:markcheck@tuv.com)  
 Fax: +49 221 806-3435

Ausstellungsdatum / Date of Issue : 25.10.2022 (day/mo/yr)





**VERIFICATION OF CONFORMITY**

**EU - The Radio Equipment Directive (RED) -**

**No. : CTB231227005REX-ZS**

**Applicant** : Dongguan Huima Synthetic Electronics Co.,Ltd  
**Address** : 3rd Floor, Bingding A, No.1 Jiangxing Road, Huangjiang Village, Huangjiang Town, Dongguan City, Guangdong Province, China  
**Manufacturer** : Dongguan Huima Synthetic Electronics Co.,Ltd  
**Address** : 3rd Floor, Bingding A, No.1 Jiangxing Road, Huangjiang Village, Huangjiang Town, Dongguan City, Guangdong Province, China  
**Product** : Baolian Lamp 2.4G Bluetooth LED Controller  
**Trade Name** : N/A  
**Model(s)** : HM-LY-2.4G, HM-LY-3K008, HM-LY-3K009, HM-LY-2.4G001, HM-LY-2.4G002, HM-LY-2.4G003

The tests that base on the above designated product Complies with the essential requirements of Directive 2014/53/EU relating to Electrical Equipment designed for use within Radio and telecommunications terminal equipment.

The test results apply only to the particular sample tested and the applicative tests carried out.

The CE markings as shown below can be affixed on product after manufacturer carry out all stipulation activities integrally of above mentioned Regulation (Directive) and preparation of necessary technical documentation as well as the conformity declaration.

This statement is based on a single evaluation of sample of above mentioned product. It does not imply an assessment of the whole production process.

Other relevant Regulation (Directive) requirement have to be observed.



Bin Mei (Director)

Jan. 19, 2024



**Shenzhen CTB Testing Technology Co., Ltd**

Add: 1&2/F., Building A, No.26, Xinhe Road, Xinqiao, Xinqiao Street, Bao'an District, Shenzhen, Guangdong, China.

Web: [www.ctb-lab.net](http://www.ctb-lab.net) Tel: 4008-707-283 Email: [ctb@ctb-lab.net](mailto:ctb@ctb-lab.net)