

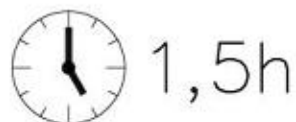

- Ⓛ **Montageanleitung**
- Ⓝ **Handleiding voor de montage**
- Ⓡ **Montaj talimatı**
- ⓕ **Notice de montage**
- Ⓒ **Montážní návod**
- ⓗ **Szereelési útmutató**
- ⓖ **Assembly Instructions**
- Ⓟ **Instrukcja montażu**
- Ⓡ **Инструкция по монтажу**
- Ⓡ **Istruzioni di montaggio**
- Ⓢ **Návod na montáž**
- Ⓡ **Instrucțiuni de montaj**
- ⓔ **Instrucciones de montaje**
- Ⓡ **Montaj Talimatı**

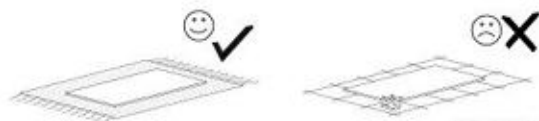

nr	L[mm]	B[mm]	T[mm]	Menge	Coll
1	983	439	70	1	2/2
102	1363	376	16	1	1/2
103	1363	376	16	1	1/2
104	894	356	16	1	2/2
105	894	351	22	2	2/2
6	1283	85	18	2	1/2
7	940	80	22	1	1/2
8	376	80	6	2	1/2
109	758	120	16	1	1/2
10	1306	906	3	1	1/2

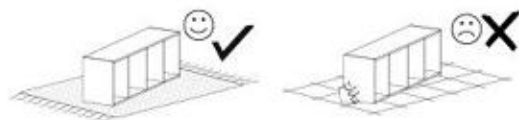
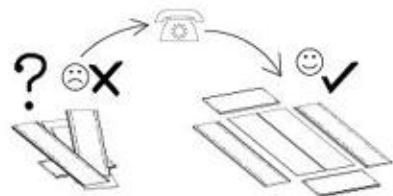
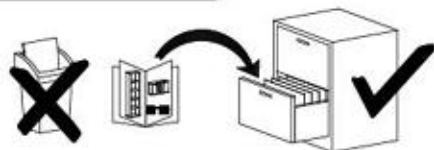
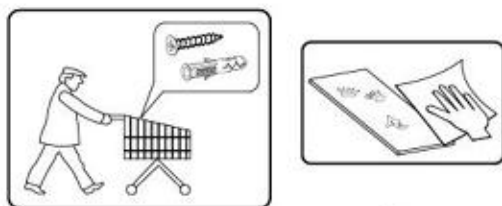
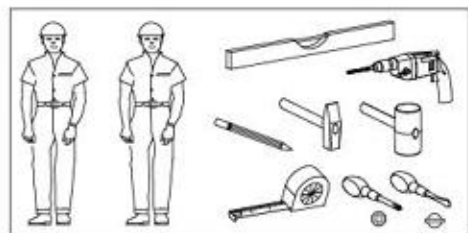
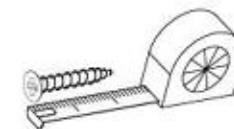
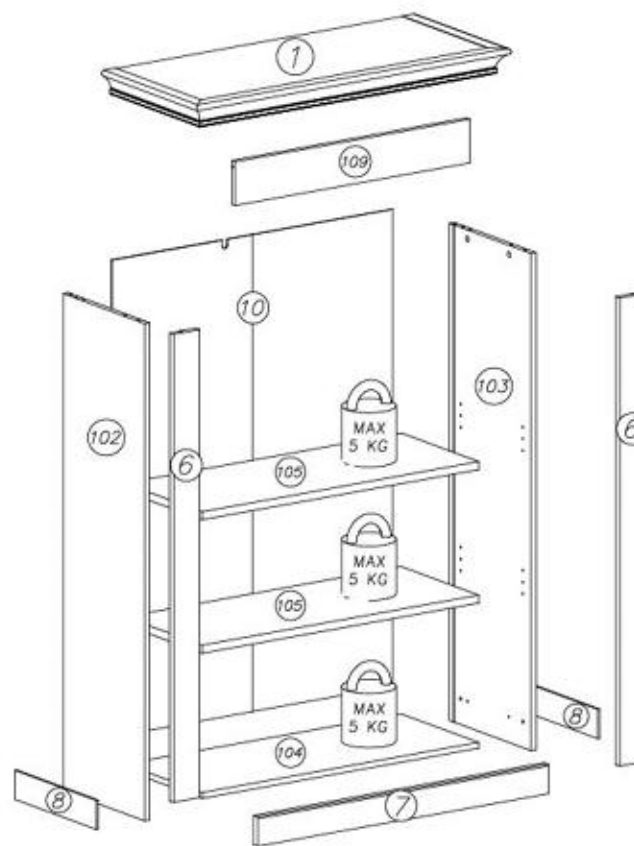

G56 4x16 x56	F2 x8	I7 ø18 x8	M11 x1
K1 ø15x12 x8	M1 x2	I1 x12	P4 x4
K10 x8	B1 ø8x35 x8	G34 3,5x16 x18	F12 x14



I

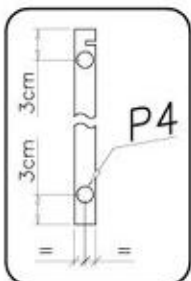
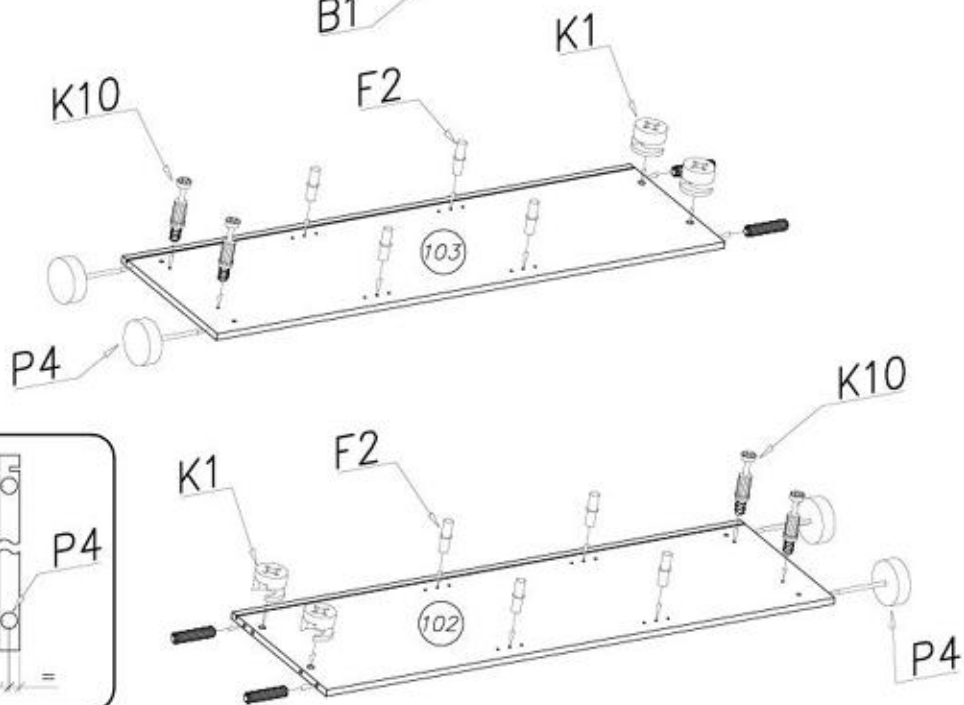
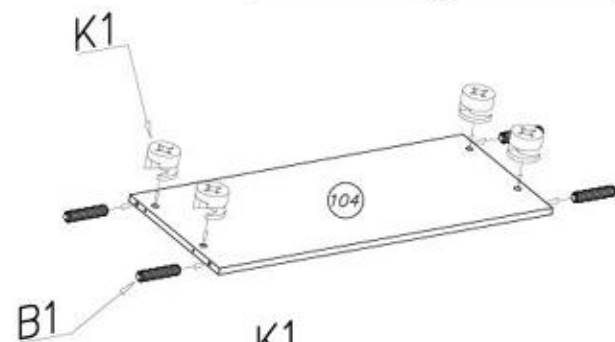
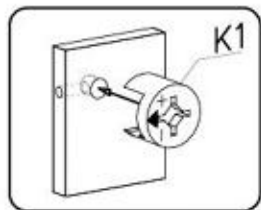
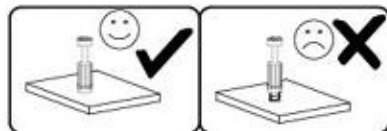
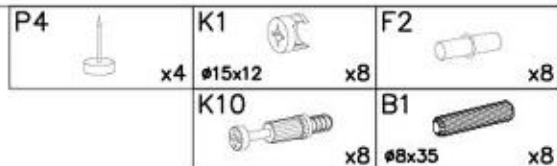
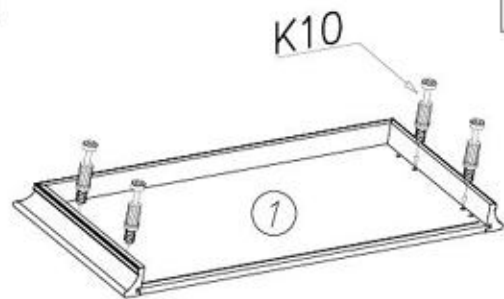

II

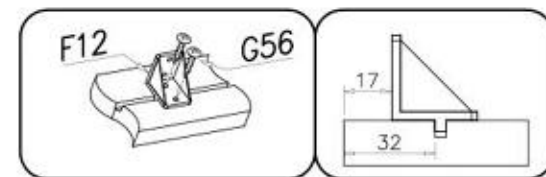
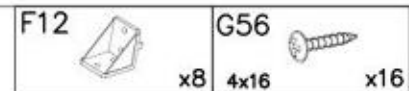
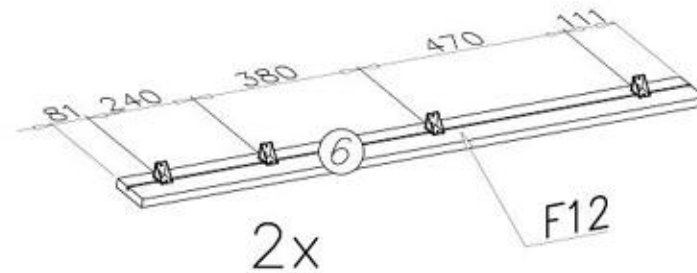

III

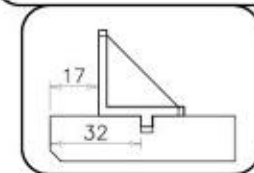
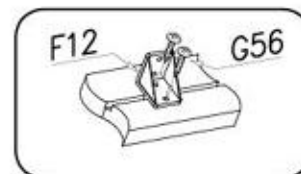
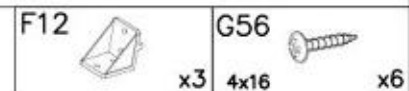
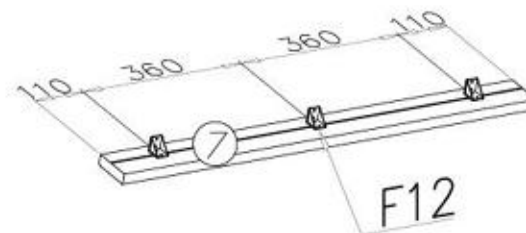



IV

F12 x3 G56 4x16 x6

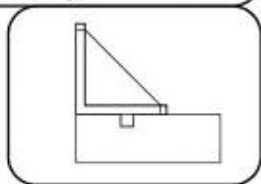
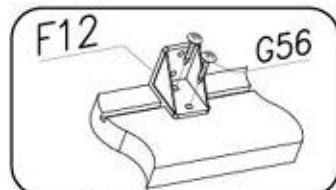
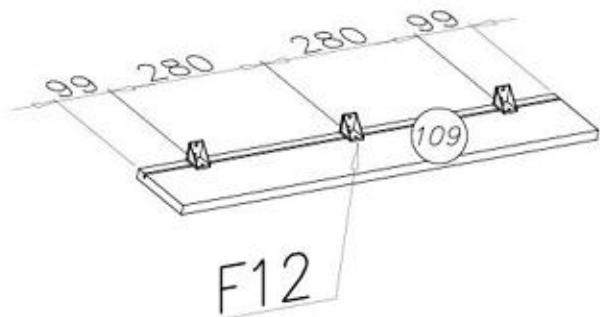

VI

G56 4x16 x16

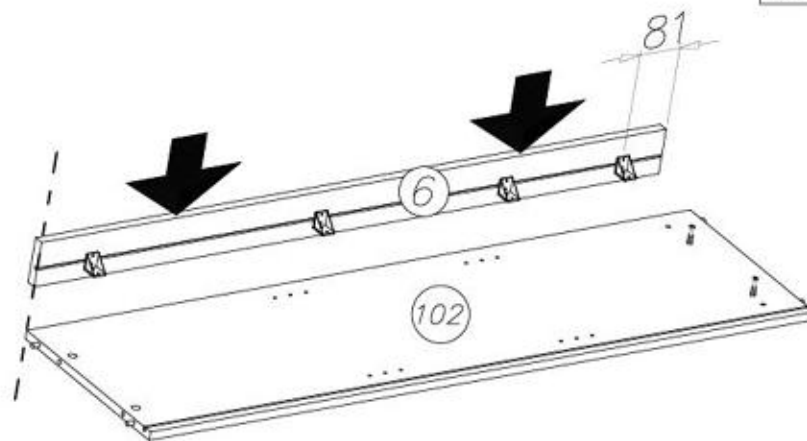

V

M1 x2 G34 3,5x16 x4

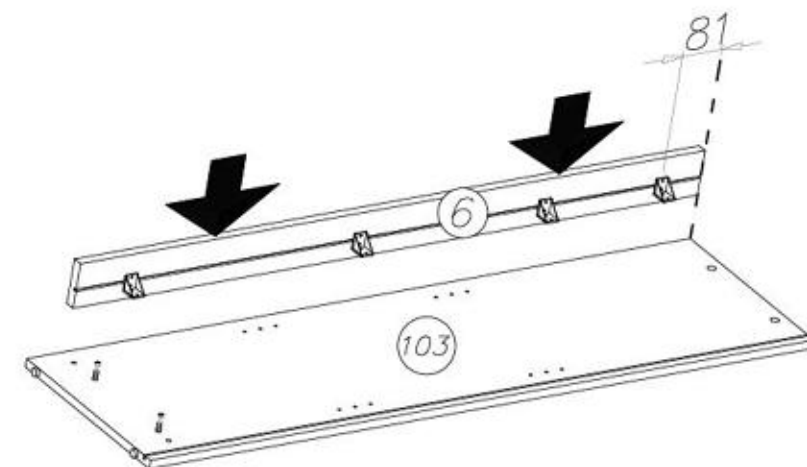
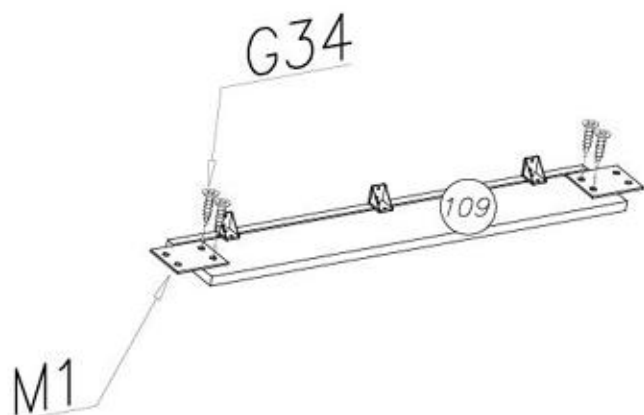
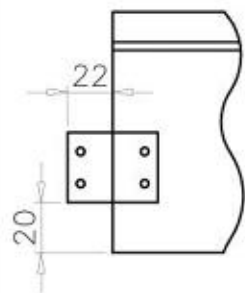



VII

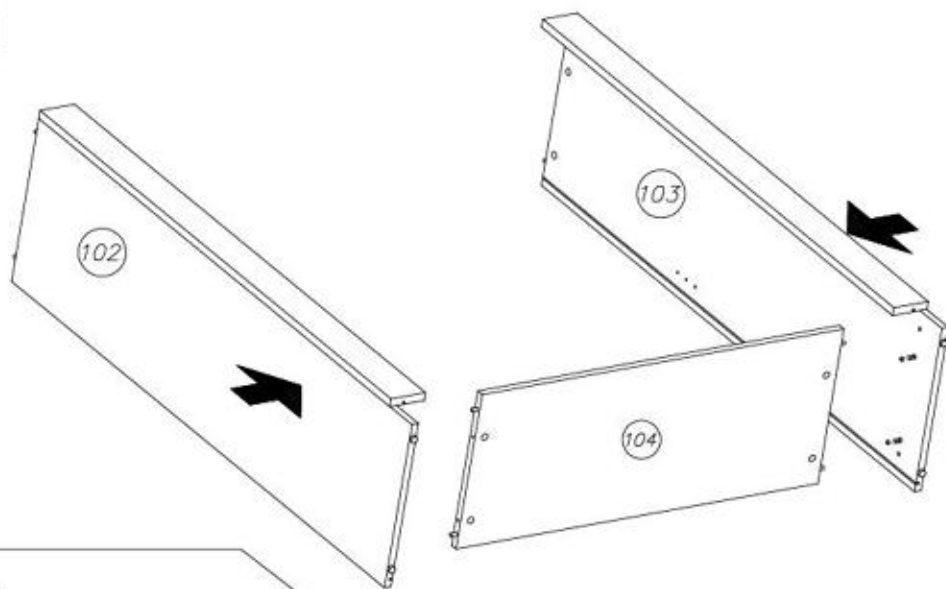

VIII

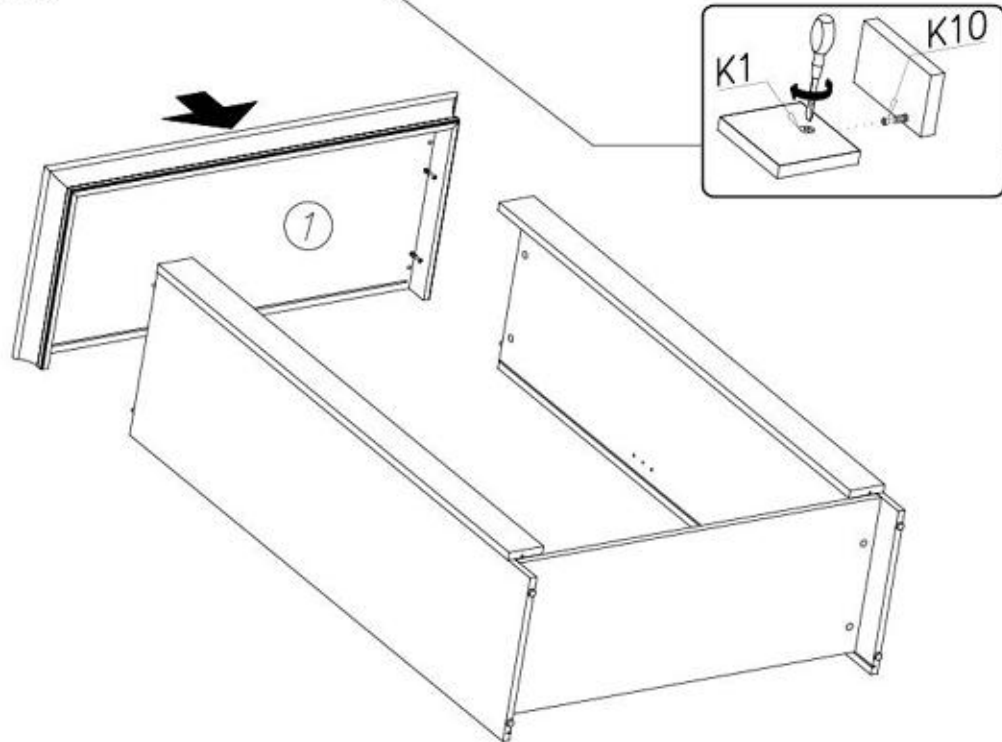

IX

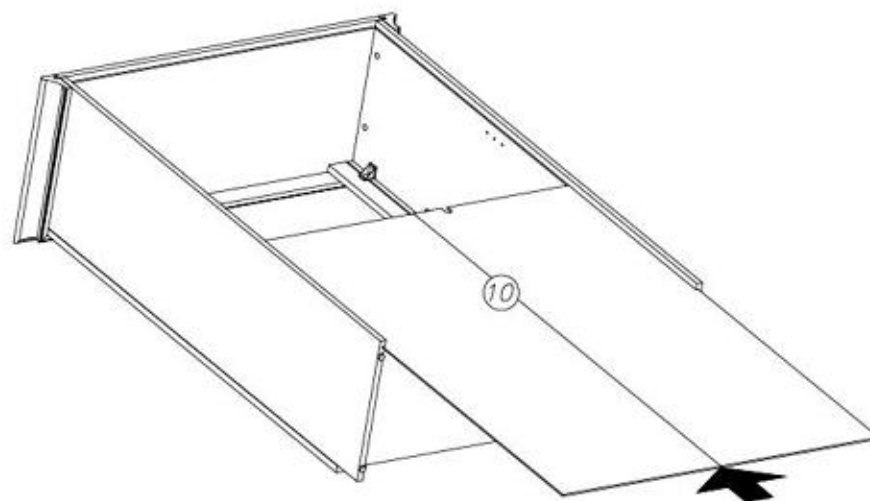

X

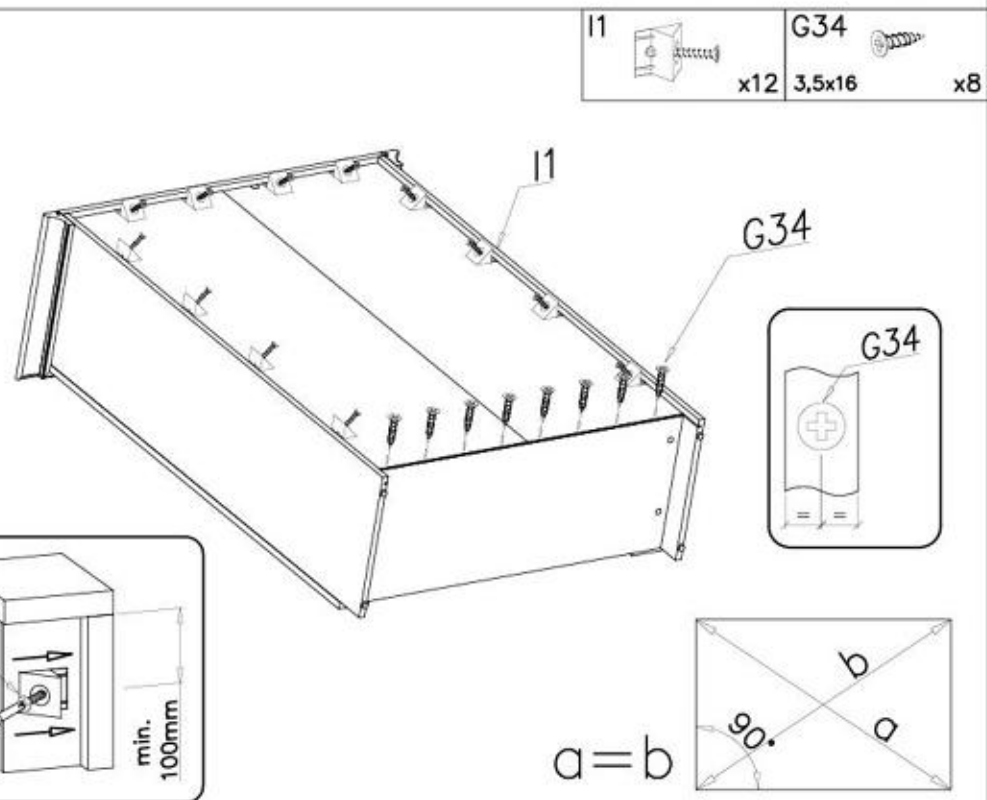



XI

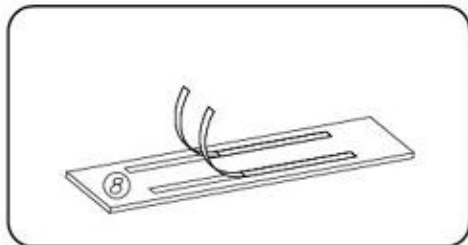
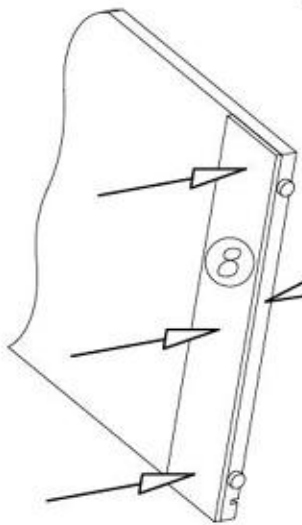
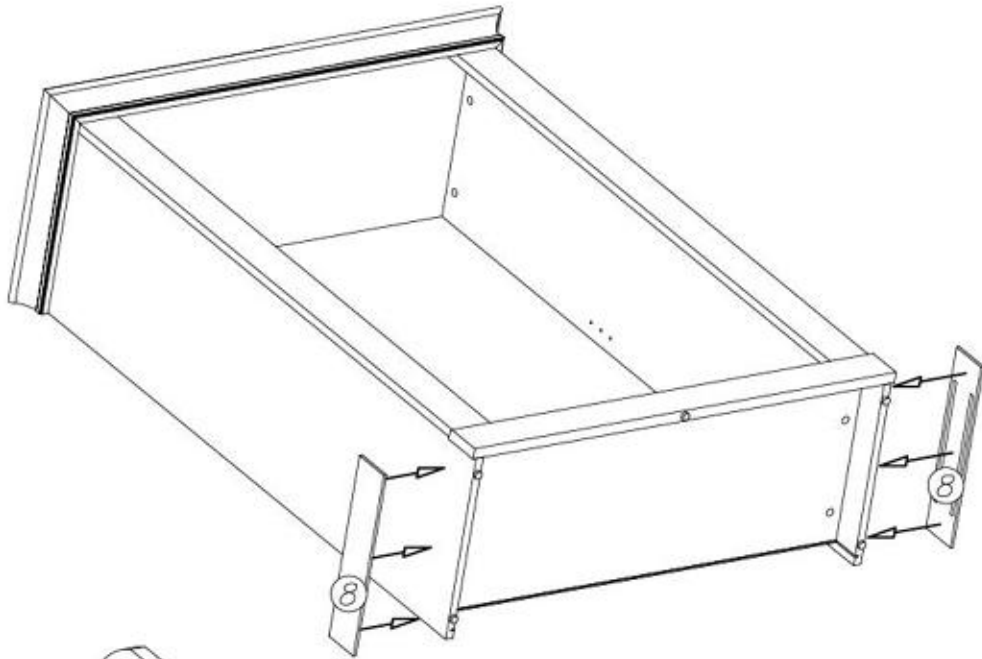

XII

G56
4x16 x6

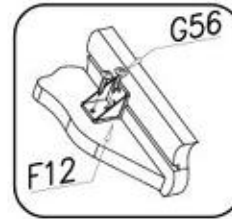
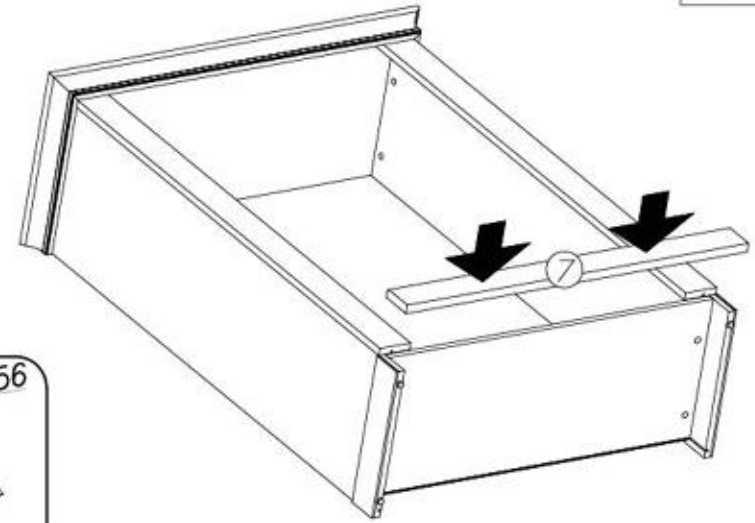

XIII

G56 4x16 x6
G34 3,5x16 x4

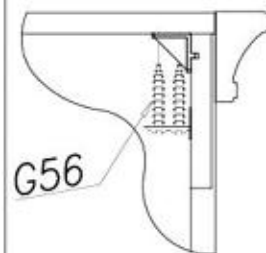
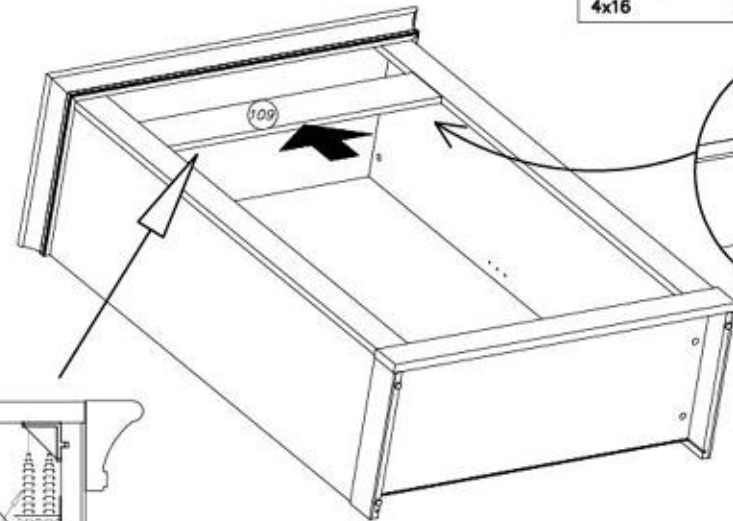



XIV

I7 ø18 x8	M11 x1	G34 3,5x16 x2
-----------------	-----------	---------------------

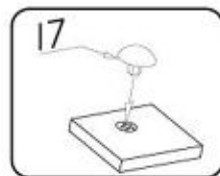
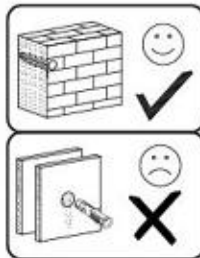
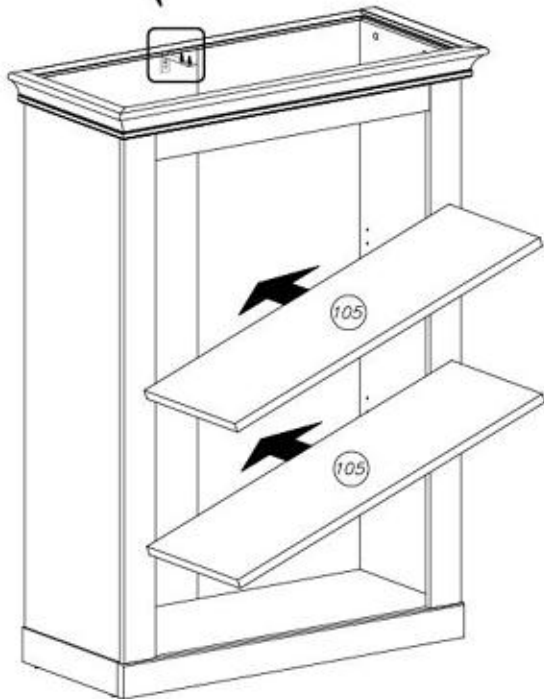
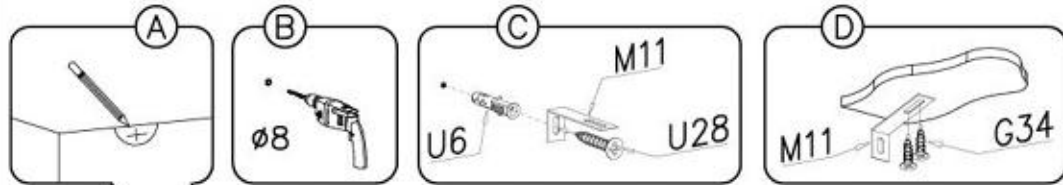

Name • Nom • Nome • Naom • Nazwa • Имя • Nr • No • N° • Номер • Č • Sz • Typ • Type • Tip • Típus • Típo • Tun

LANDHAUS

--

13

D Unter: Dienstservice für Beschädigte
Solange Ihnen ein Beschädigter liefert, können Sie diese Servicekarte direkt an die unternennende Nummer senden. Wir können allerdings nur Beschädigte auf diesem Weg verschicken. Sollen Sie eine andere Benachteiligung an Ihrem Möbelstück haben, so wenden Sie sich bitte direkt an Ihr Möbelhaus.

GB Our direct order service for fitting
If a fitting should be missing to you, you know this service card directly following number boxes, you can in this way send away however only fitting. If you should have another objection to your piece of furniture, then they turn please to your furniture house.

CZ Nežte přímé služby pro lovění
Chybi-li vám nějaký díl z lovení, můžete tuto službu kartu odložit přímo na náš uvedený číslo. Tuto kartu však můžeme poslat jen díky lovení. Pokud byste měli nějaký jiný problém, obraťte se přímo na svého prodejce nábytku.

F Ne pas étudier le notice de montage
Nécessaire les pièces correspondantes votre meuble. Regardez et contrôlez le fournisseur. Veuillez - vous de l'outillage nécessaire. Aménagez - vous une zone de montage. Procédez au montage. Ne jamais forcer les assemblages. Respectez les vis dans quelques temps d'usage. Garder votre notice de montage, si une pièce venait à manquer, elle serait le plus sûr moyen de communiquer avec votre magasin.

I Il nostro servizio diretto per l'ordine delle forniture
Nel caso vi mancassero dei pezzi, potete spedire fax questa carta di servizio direttamente al seguente numero. Per altri problemi al vostro mobile, potete rivolgervi al vostro mobilificio.

BG Директно обслужаване на гръбнак части "Добавяне"
Ако ви липне някаква част от гръбнака, можете да изпратите тази карта директно на посочения номер. Може да имате допълнителни въпроси, тогава се обърнете директно към вашия магазин за мебели.

NL Directe service voor losse onderdelen
Wanneer er een onderdeel mist licht u deze servicekaart direct aan onderaannemer faxnummer sturen. Wij kunnen alleen langa deze weg onderdelen verspreken. Mocht u een ander probleem aan uw meubel hebben verzoeken wij u contact op te nemen met uw meubeldealer.

PL Należy bezpośrednio serwisować montażowych
Jeżeli brakuje części koniecznych do montażu, prosimy o przesłanie nam tej karty serwisowej na nasz podany numer faxu. Materiały w ten sposób przysyłane powinny być dokładnie opisane. W przypadku innych ewentualnych dotychczasowych problemów, prosimy o skierowanie ich do własnego meblowego w którym został dokonany zakup.

HR Servis za dijelove
U slučaju da nedostaje neki od dijelova molimo vas da na ovaj način obavite. Fax broj posaljete ovaj servisni obrazac. Na ovaj način mogu se dostaviti samo dijelovi. U slučaju da imate dodatne prigovore vezane uz komad namještaja molimo vas da se obratite izravno trgovini namještaja gdje je isti kupljen.

HU Közvetlen szolgáltatások esetén
Ha hiányzik egy részlet, ezt a kártyát közvetlenül a felszolgáló az alábbi telefonszámra küldje. Amennyiben további kérdéseket szeretne feltenni, forduljon közvetlenül a boltjához.

SK Naše priamo služby pro lovění
Ak by vám chýbala nejaká časť lovení, môžete poslať túto službu kartu priamo na náš uvedený faxové číslo. Táto kartu však môžeme poslať iba vďaka lovení. Ak by ste mali iný problém, obráťte sa priamo na vašu predajcu nábytku.

SLO Naše direktno službe storitve za dijelove
Če vam manjka kakikoli delov, lahko to storimo karico pošljete po faxu direktno na spodnje število. Po tej poti vam lahko pošljemo samo delovje. Če imate kakikoli kakšen drug del problema, se obrnite neposredno na vašo trgovino pohištva.

RO Servis-ul nostru direct pentru furnizarea
In cazul in care vi lipseste o piesa de furnizare puteti sa trimiti direct aceasta card de service pe fax la numarul de mai jos. Noi nu putem expedia piese de furnizare decat pe aceasta cale. Dacă aveți și altă reclamație referitoare la piesa de mobilier, atunci vă rugăm să vă adresați direct la magazinul din care ați cumpărat.

RUS Наш прямой сервис для поставки фурнитуры
Если отсутствует, что Вам не хватает того или иного элемента фурнитуры, Вы можете отправить сервисную карту по факсу непосредственно на номер указанного ниже. Однако, если у Вас имеются иные претензии относительно приобретения мебели, пожалуйста, обращайтесь непосредственно в организацию, осуществляющую продажу.

S Vår direkte service for beslagsettelse
Om du sender en beslagsettelse kan du fåse disse servicekort direkte til nummer som angives ned. Men, på det disse er det ikke mulig å sende ut andre beslagsettelse på det. Om du vil reklamere din mobil er en annen anledning må du kontakte ditt møbelhus direkte.

ES Nuestro servicio directo para accesorios
Si le falta algún accesorio, puede enviar esta tarjeta de servicio directamente a la siguiente dirección. No obstante, por este mismo solo podemos enviar accesorios. Si tiene alguna otra objeción sobre su mueble, consulte directamente con su mueblero.

TR Doğrudan için donatılar servisleri
Bir donatıya ihtiyacınız ya da servisler için doğrudan mesajlar buların sadece doğrudan mail vasıtasıyla. Sadece bu yolla donatılar gönderilebilir. Mobilya ile ilgili diğer sorunlarınız varsa lütfen doğrudan mobilya satıcınıza danışın.

G56 4x16 x...	P4 x...	F12 x...
M11 x...	F2 x...	I7 ø18 x...
K1 ø15x12 x...	M1 x...	I1 x...
K10 x...	B1 ø8x35 x...	G34 3,5x16 x...



Name • Nom • Nome • Naam • Nazwa • Jméno • Νόμος • Név • Denumire • Isim • Имя	Nr • No • N° • Номер • Č • Sz	Typ • Type • Tip • Тіpus • Тіро • Тип
LANDHAUS	--	13

D Unser Direktservice für Beschädigte
Sollte Ihnen ein Beschädigter Schaden, können Sie diese Servicekarte direkt an die unternahmende Vertretung senden. Wir können allerdings nur Beschädigte auf diesem Weg verschicken. Sollen Sie eine andere Beanstandung an Ihrem Möbelstück haben, so wenden Sie sich bitte direkt an Ihr Möbelhaus.

GB Our direct order service for fitting
If a fitting should be missing to you, you know this service card directly following number boxes, you can in this way send away however only fitting. If you should have another objection to your piece of furniture, then they turn please to your furniture house.

CZ Nežte přímé služby pro ložení
Chytlí-li vám nějaký díl k ložení, můžete tuto službu kartu odeslat přímo na náš ústřední úřad. Tuto kartu však můžeme poslat jen sly ložení. Pokud byste měli nějaký jiný nářek, obraťte se přímo na svého prodejce nábytku.

F Ne pas oublier le notice de montage
N'oubliez pas la notice de montage. Répétez et contrôlez les quantifiants. Montez - vous de hautage nécessaires. Aménager - vous une zone de montage. Procédez au montage. Ne jamais forcer les assemblages. Remarque: les vis sont prévues à l'avance d'usage. Consultez votre notice de montage, si une pièce venait à manquer, elle serait le plus sûr moyen de communiquer avec votre magasin.

I Il nostro servizio diretto per l'ordine delle forniture
Nel caso di mancanza del pezzo, potete spedire fax questa carta di servizio direttamente al seguente numero. Per altri reclami al vostro mobile, potete rivolgervi al vostro mobilificio.

BG Длъжно обръщение за гръбна част "Длъжен"
Ако обръщане вие не е получено, можете да изпратите тази карта директно на нашия център за обслужване. Можем да ви предоставим само обръщенията. Ако имате друг въпрос, моля, обърнете се директно към вашия магазин.

NL Directe dienstverlening voor schade
Wanneer er een onderdeel mist kunt u deze servicekaart direct aan onze afdeling beschadigde sturen. Wij kunnen alleen schade van het onderdeel verspreiden. Mocht u een ander probleem zijn uw meubel hebben verzoeken wij u contact op te nemen met uw meubeldealer.

PL Należy bezpośrednio przesyłać kartę montażową
Jeżeli brakuje części koniecznych do montażu, prosimy o przesłanie nam tej karty serwisowej na niżej podany numer faxu. Możemy w ten sposób przysłać potrzebne tylko brakujące części. W przypadku innych skarg dotyczących mebli, prosimy o skierowanie ich do salonu meblowego w którym został dokonany zakup.

HR Servis za šteta
U slučaju da nedostaje neki od dijelova molimo vas da na ovaj način obavite fax broj poslate ovaj servisni obrazac. Na ovaj način mogu se dostaviti samo dijelovi. U slučaju da imate dodatne prigovore vezane uz štetu molimo vas da se obratite tojimo trgovini namontage gdje je šteta nastala.

HU Díszközvetlenül visszaküldés
Ha néhány alkatrész hiányzik, ezt a felhívó kártyánkat közvetlenül az alábbi címre küldje meg. Csak a hiányzó alkatrészeket tudjuk így küldeni. Amennyiben másféle reklamációt áll fel, biztossággal kérjük, forduljon közvetlenül a boltjához.

SK Máš priamo servis pre škodu
Ak by Vám chýbalo nejaké súčasťovanie, môžete poslať túto službu kartu priamo na náš ústredný úrad. Túto kartu však môžeme poslať iba so škodou. Ak máte ďalšie otázky, obráťte sa priamo na Vašu predajnú miestu.

SLO Nežte direktno službo štete
Če vam manjka kakšno delce, lahko to servisu kartico pošljete po faxu direktno na našo službo. Po tej poti vam lahko pošljemo samo delce. Če imate kakšne druge pritožbe, se obrnite neposredno na vašo trgovino.

RO Servis-ul nostru direct pentru fara
In cazul in care va lipseste o piesa de mobilier puteti sa trimiti direct aceasta card de service pe fax la numarul de mai jos. Noi nu putem expedia piesa de mobilier decât pe acest fel de mod. Servis-ul nostru este destinat doar pieselor care lipsesc. Pentru toate celelalte probleme, te rugam sa te adresezi direct la magazinul din care ai cumparat.

RUS Наш прямой сервис для клиентов
Если ожидается, что Вам не хватает той или иной детали мебели, Вы можете отправить сервисную карту по факсу непосредственно на нижеприведенный номер. Однако, только детали мебели мы можем отправить этим способом. Для всех остальных жалоб или претензий относительно проблемной мебели, пожалуйста, обращайтесь непосредственно в магазин, осуществляющий продажу.

S Vår direkte service for skadade
Om du saknar en delar eller kan du faxa detta servicekort direkt till vårt kontor angår skada. Till på ett sätt är det enda möjliga sätt att skicka delar till dig. Om du vill reklamera din möbel är en annan anledning måste du kontakta ditt möbelslagare.

ES Nuestro servicio directo para averías
Si le falta algún accesorio, puede enviar esta tarjeta de servicio directamente a la siguiente dirección. No obstante, por esta vía sólo podemos enviar accesorios. Si tiene alguna otra objeción sobre su mueble, consulte directamente con su mueblera.

TR Doğrudan için zararlı servisleri
Bir parçanın eksikliği ya da servisi kartını doğrudan aşağıdaki numaraya gönderebilirsiniz. Sadece bu şekilde doğrudan parçaları gönderebiliriz. Diğer tüm şikayetler için doğrudan satın aldığınız mobilya mağazasına başvurmalısınız.

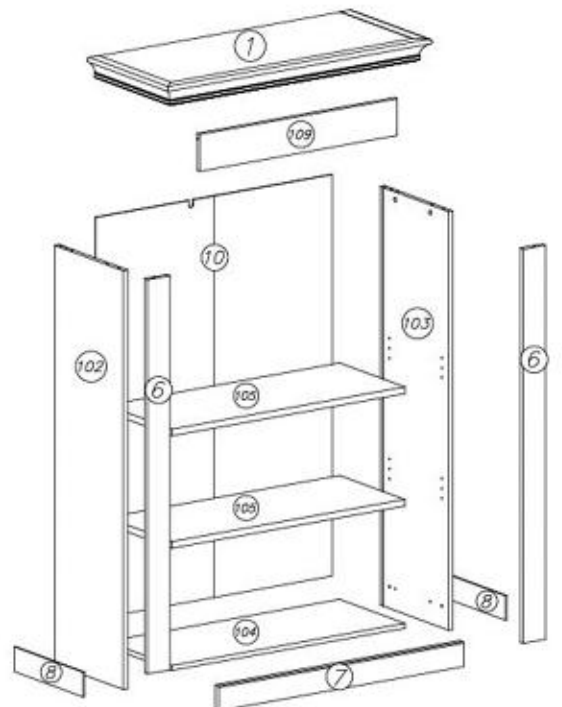

nr	L[mm]	B[mm]	T[mm]	Menge	Coll
1	983	439	70	2/2	
102	1363	376	16	1/2	
103	1363	376	16	1/2	
104	894	356	16	2/2	
105	894	351	22	2/2	

nr	L[mm]	B[mm]	T[mm]	Menge	Coll
6	1283	85	18	1/2	
7	940	80	22	1/2	
8	376	80	6	1/2	
109	758	120	16	1/2	
10	1306	906	3	1/2	

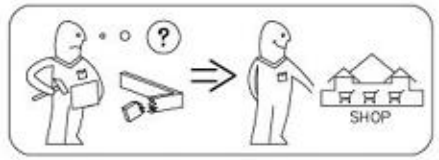

- D** Montageanleitung
- NL** Handleiding voor de montage
- TR** Montaj talimatı
- F** Notice de montage
- CZ** Montážní návod
- HU** Szerelési útmutató
- GB** Assembly Instructions
- PL** Instrukcja montażu
- RU** Инструкция по монтажу
- IT** Istruzioni di montaggio
- SK** Návod na montáž
- RO** Instrucțiuni de montaj
- ES** Instrucciones de montaje
- TR** Montaj Talimatı

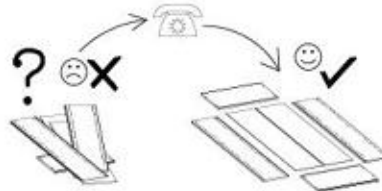
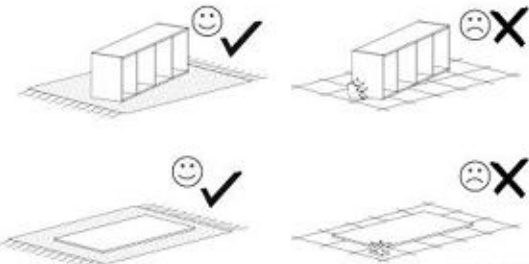
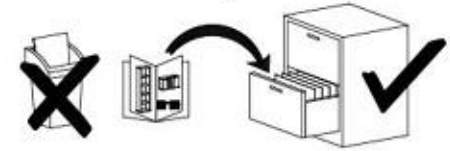
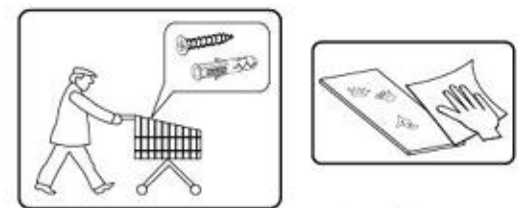
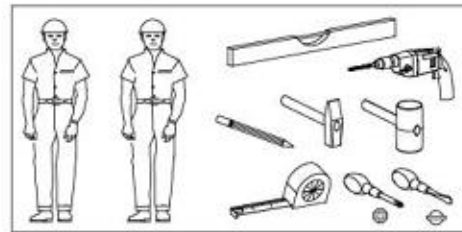

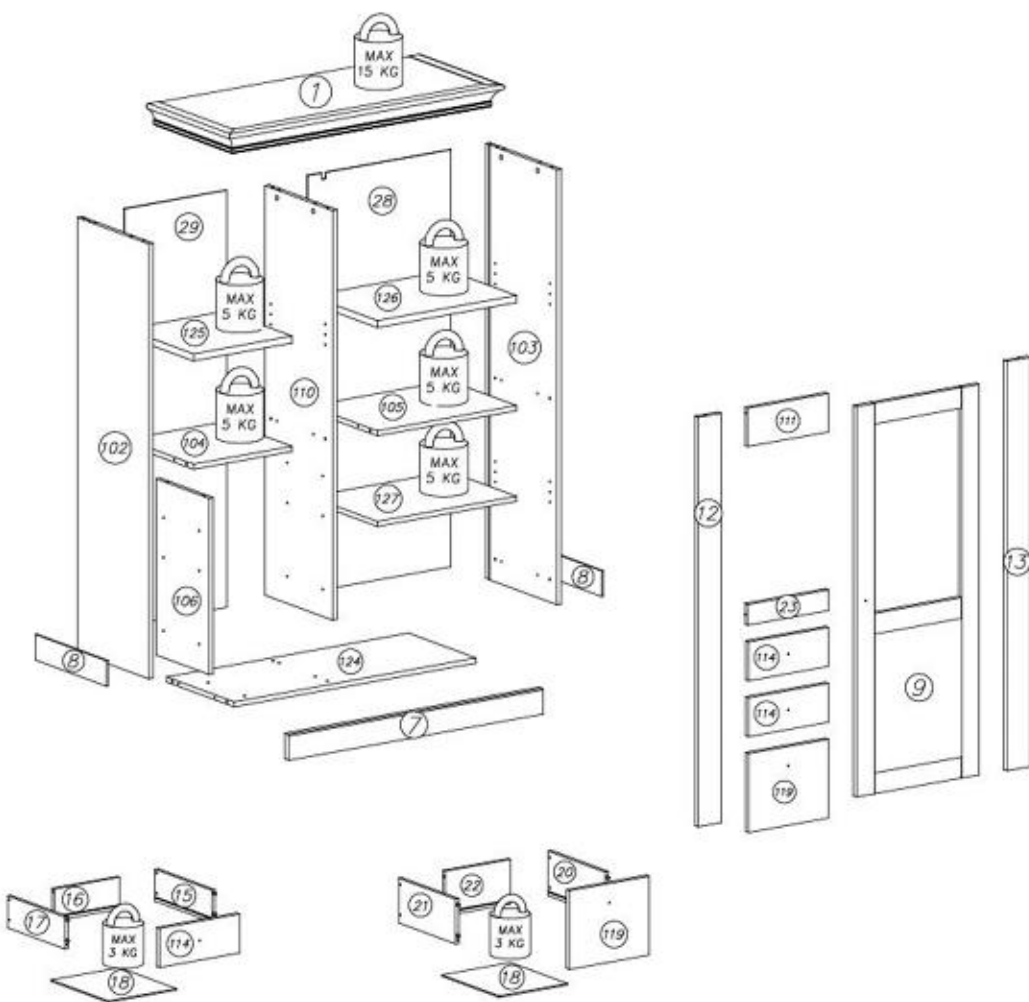

nr	L[mm]	B[mm]	T[mm]	Menge	Cat
1	1017	439	70	1	2/2
102	1363	376	16	1	1/2
103	1363	376	16	1	1/2
104	364	356	16	1	2/2
105	514	356	16	1	2/2
106	553	278	16	1	2/2
7	940	80	22	1	2/2
8	376	80	6	2	1/2
9	1223	454	18	1	1/2

nr	L[mm]	B[mm]	T[mm]	Menge	Cat
110	1284	356	16	1	1/2
111	298	120	16	1	1/2
12	1283	85	18	1	1/2
13	1283	85	18	1	1/2
114	295	122	16	2	2/2
15	300	100	12	2	2/2
16	241	100	12	2	1/2
17	300	100	12	2	2/2
18	251	301	3	3	2/2
119	295	247	16	1	2/2

nr	L[mm]	B[mm]	T[mm]	Menge	Cat
20	300	140	12	1	1/2
21	300	140	12	1	1/2
22	241	140	12	1	1/2
23	298	65	16	1	2/2
124	894	356	16	1	2/2
125	364	351	22	1	2/2
126	514	336	22	1	2/2
127	514	351	16	1	2/2
28	1306	530	3	1	1/2
29	1306	378	3	1	1/2

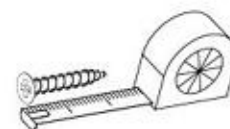
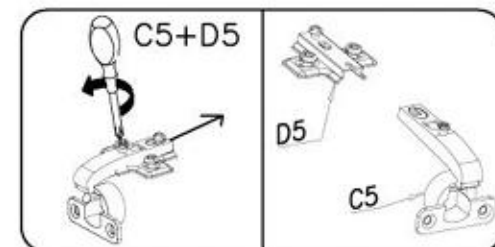

S2		x12	F4		x1	G56		4x16	x60	P27		x1	
C5+D5		x3	W1		x2	A1		ø7x50	x4	M1		x1	
A6		ø7x40	x12	W2		x1	N15		M4x25	x4	E93		x4
K1		ø15x12	x18	H23		x3	G20		5x13	x24	F2		x12
K15		ø15x12	x18	I7		x18	M11		x1	P4		x5	
				I1		x12	P4		x5	F12		x15	
				B1		ø8x35	x22	G34		3,5x16	x50		

4/21

LANDHAUS 22



I

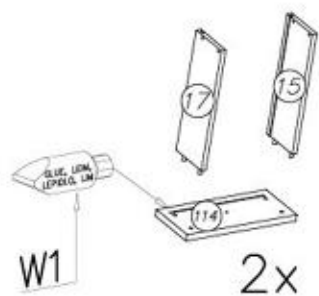

W1 2x

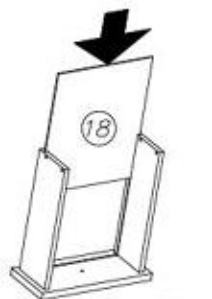

2x



0,5h

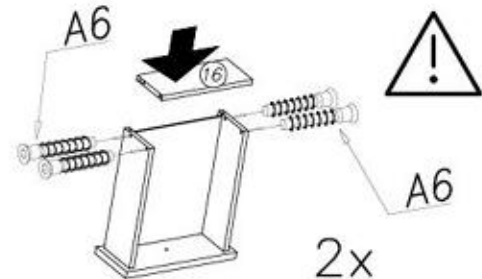

2x

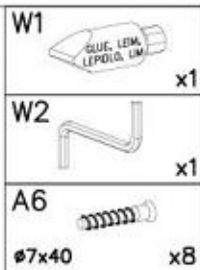

W1 x1

W2 x1

A6 $\phi 7 \times 40$ x8

II

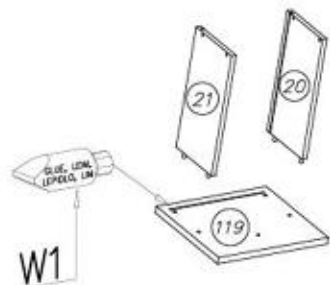

W1

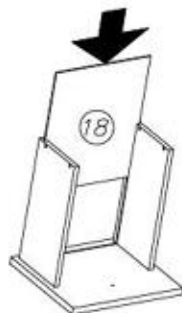

0,5h

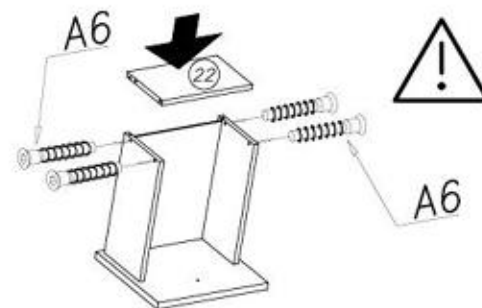

A6

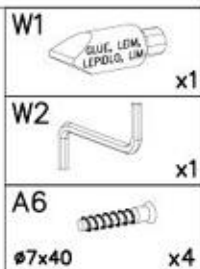

W1 x1

W2 x1

A6 $\phi 7 \times 40$ x4

5/21

LANDHAUS 22

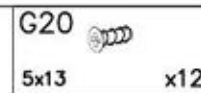
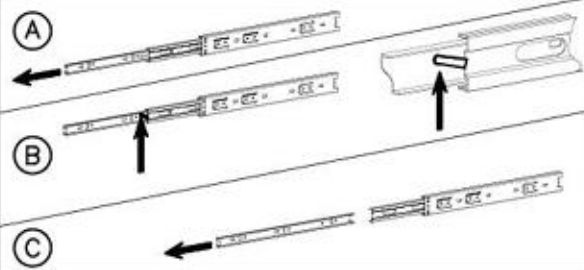

G20 5x13 x12



H23 H35-300mm x3

III

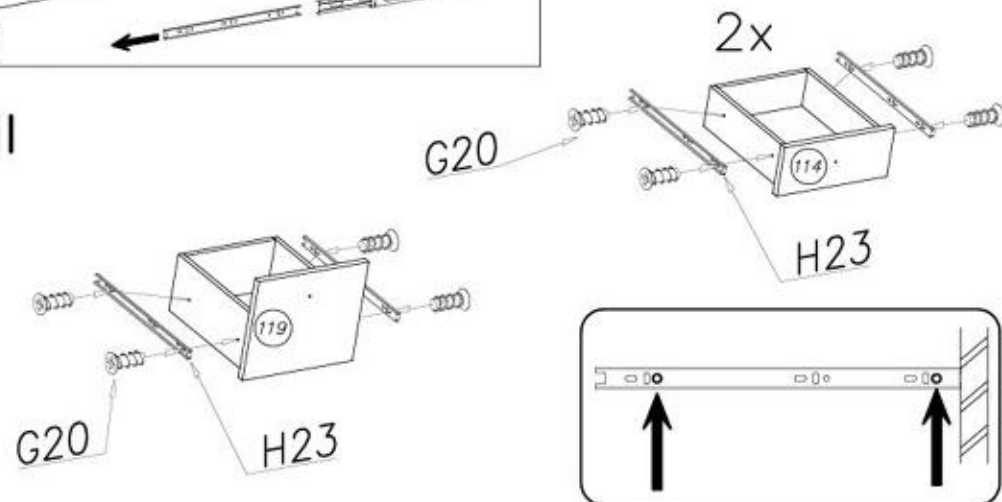

G20

2x

H23

G20

H23

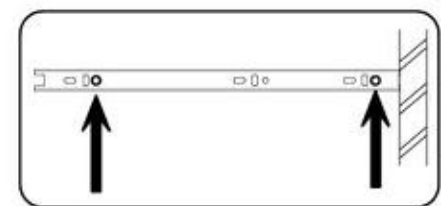

IV

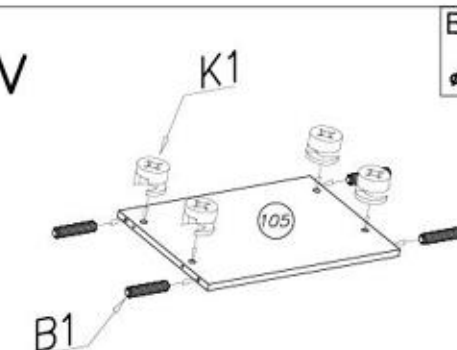

B1

K1

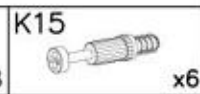
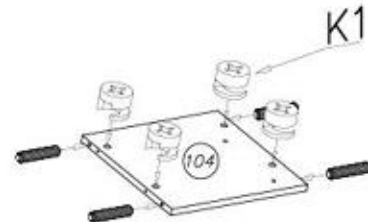
B1 $\phi 8 \times 35$ x8K1 $\phi 15 \times 12$ x8K15 $\phi 8 \times 15$ x6

K1

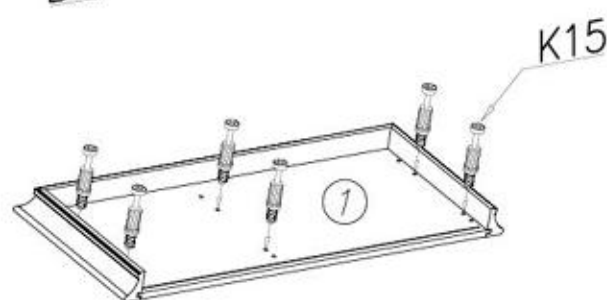

K15

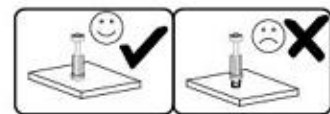
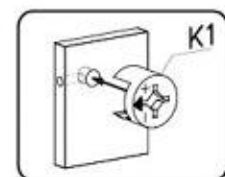

6/21

LANDHAUS 22



V

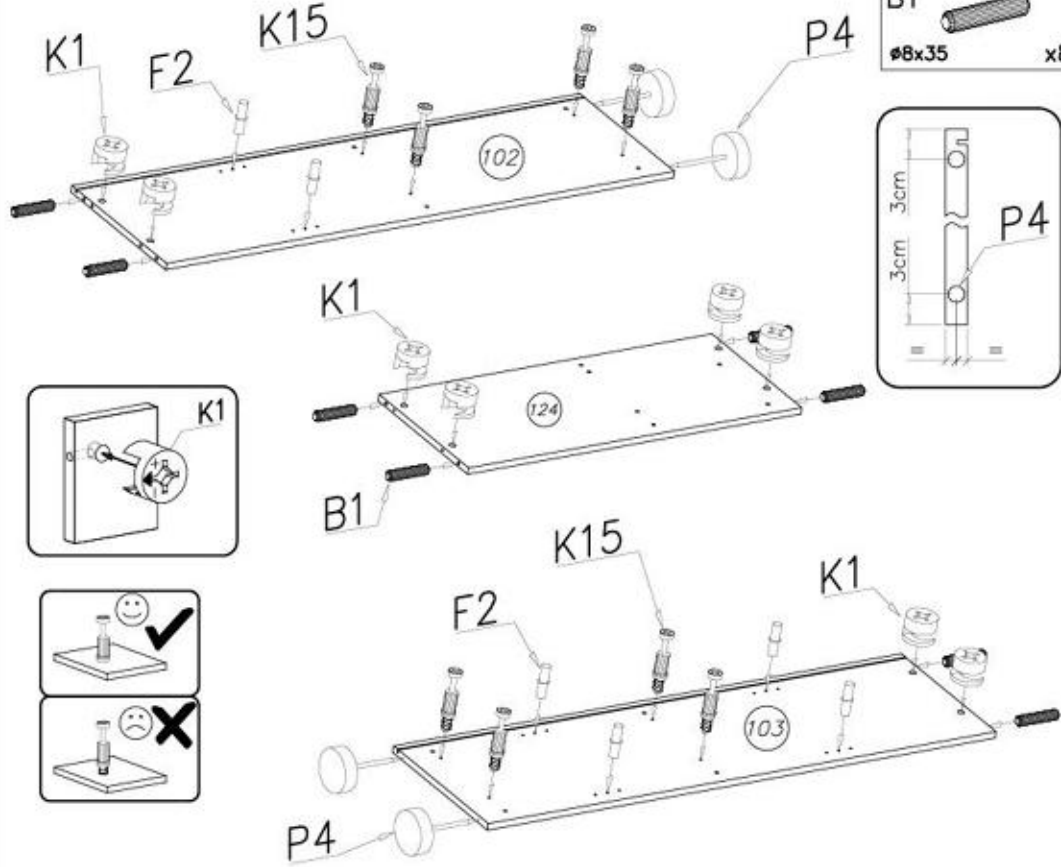
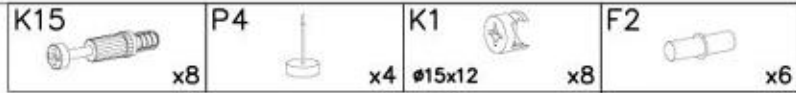

VI

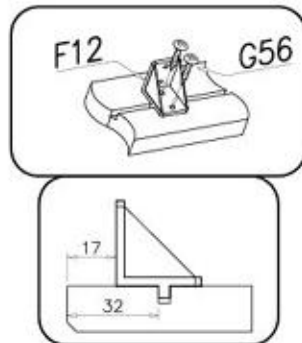
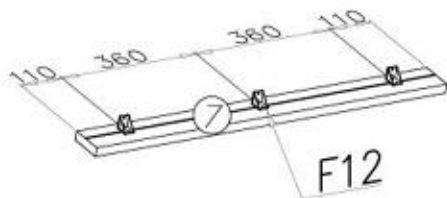
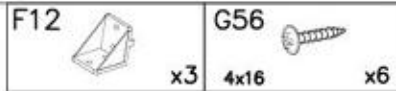

7/21

LANDHAUS 22



VII

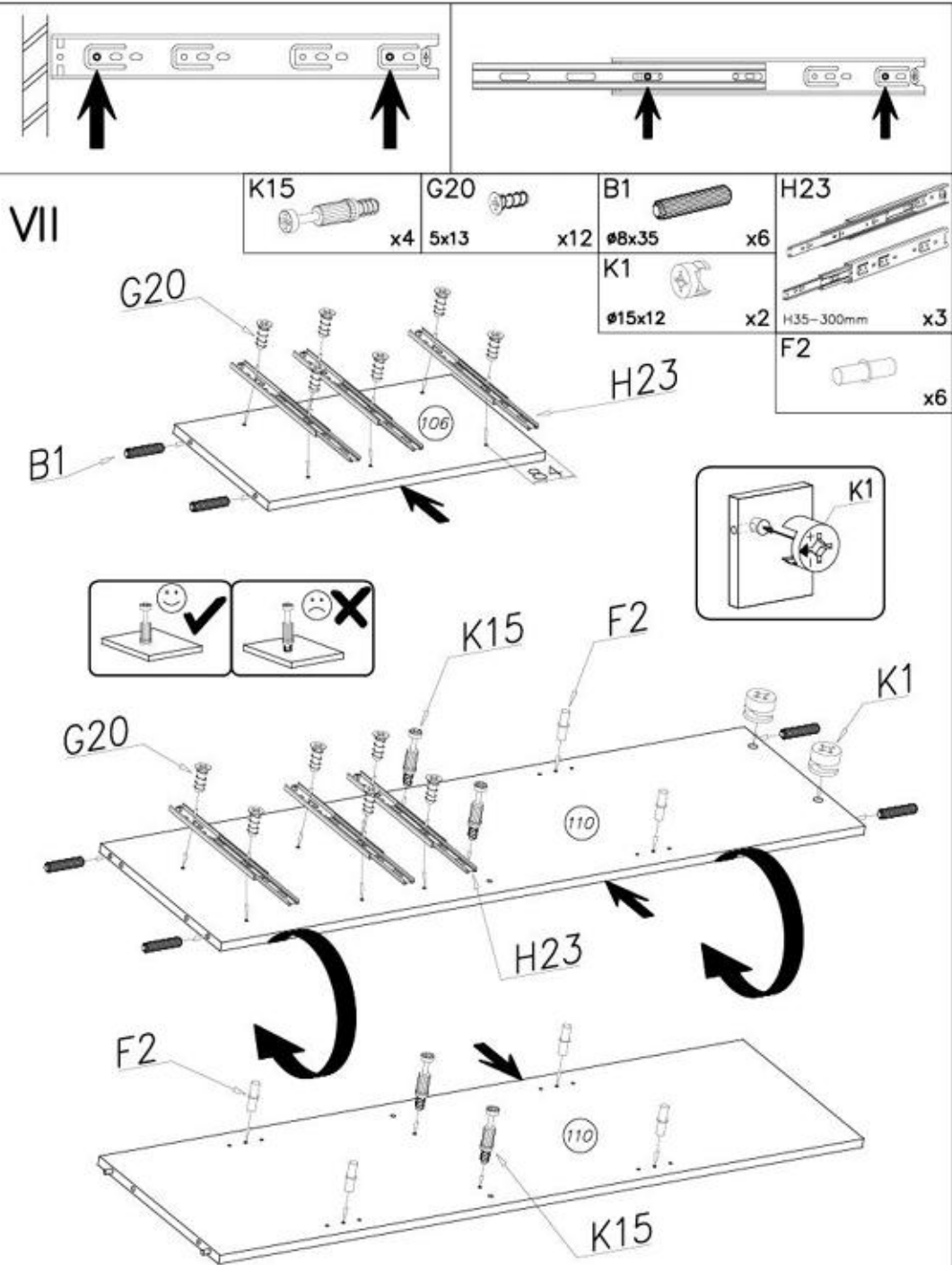

8/21

LANDHAUS 22



VIII

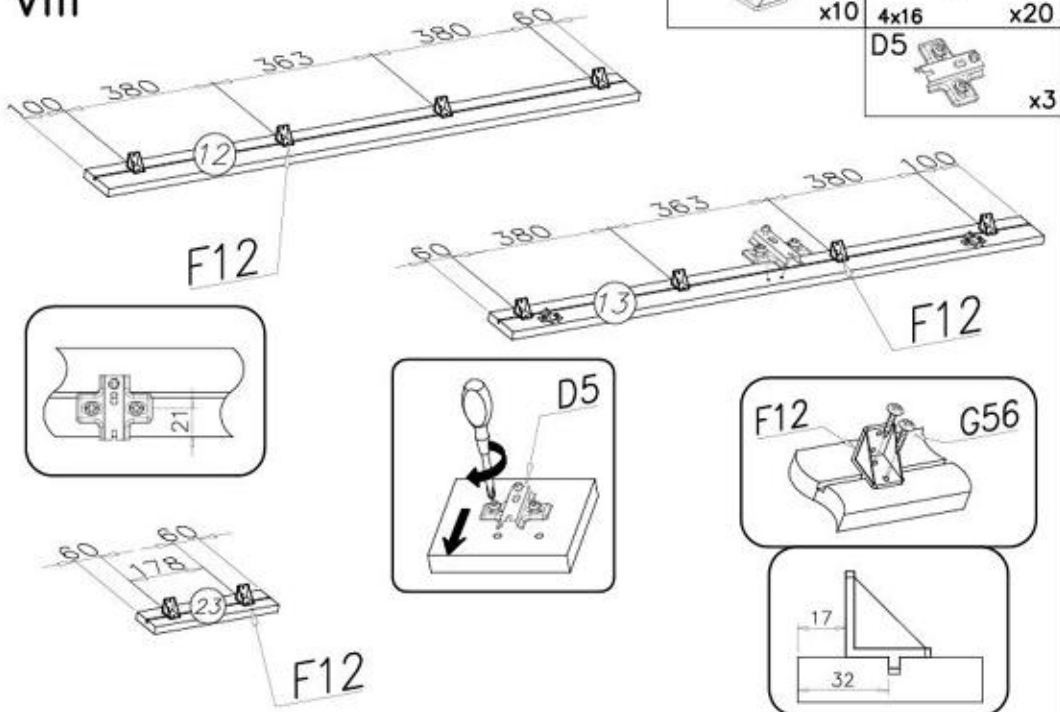

9/21

LANDHAUS 22



XI

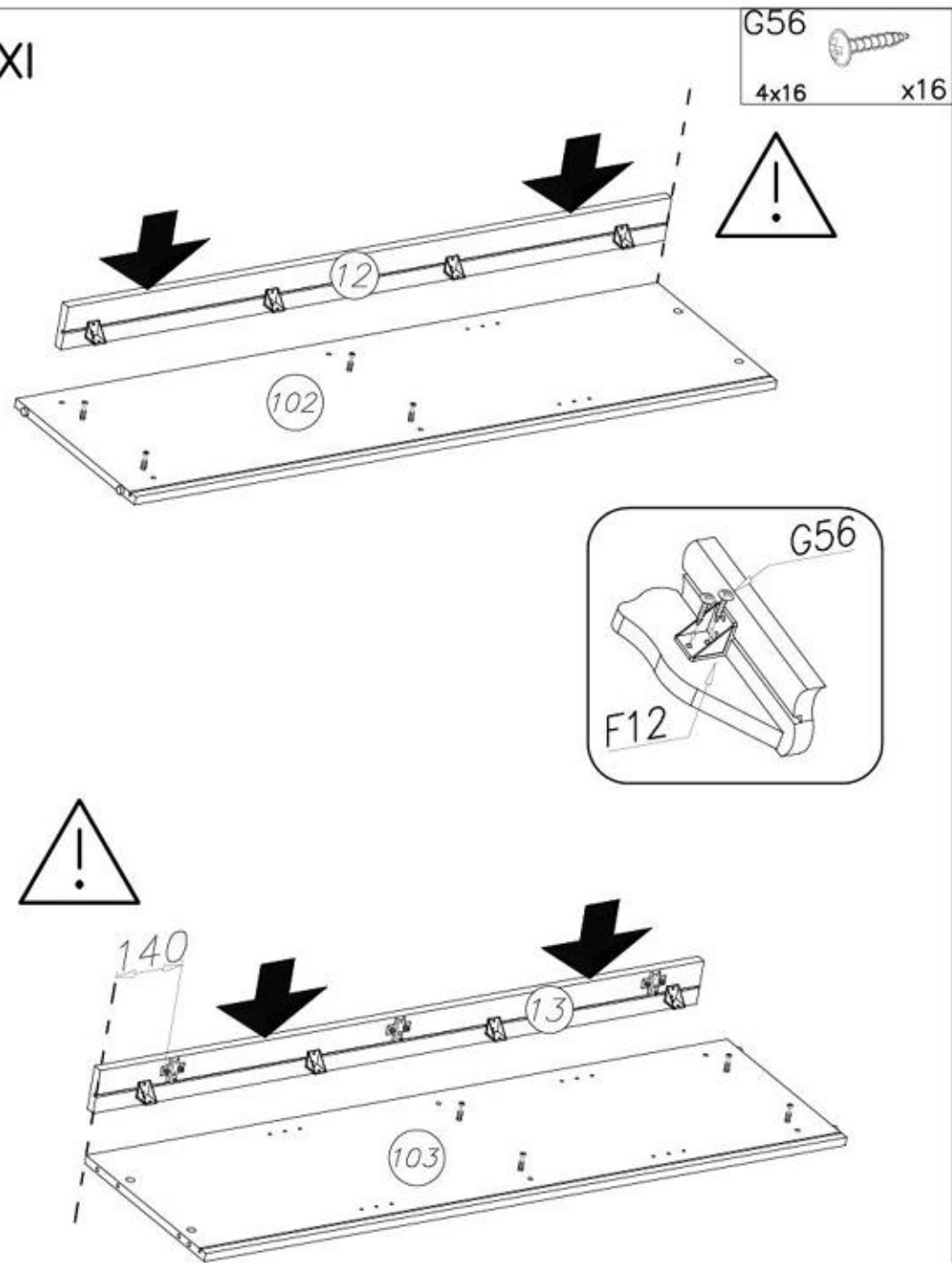

IX

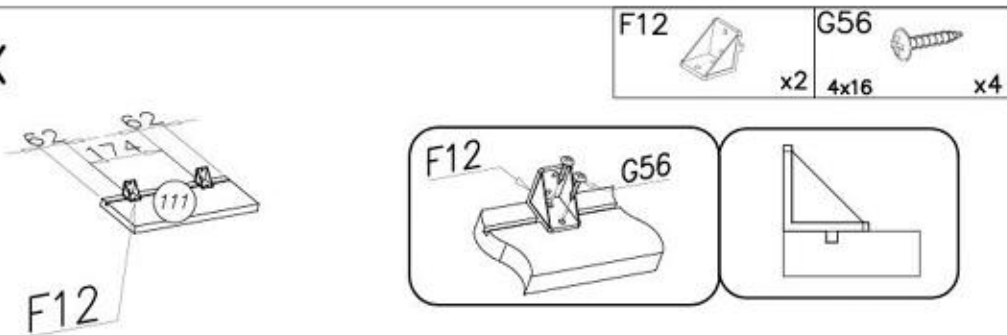

X

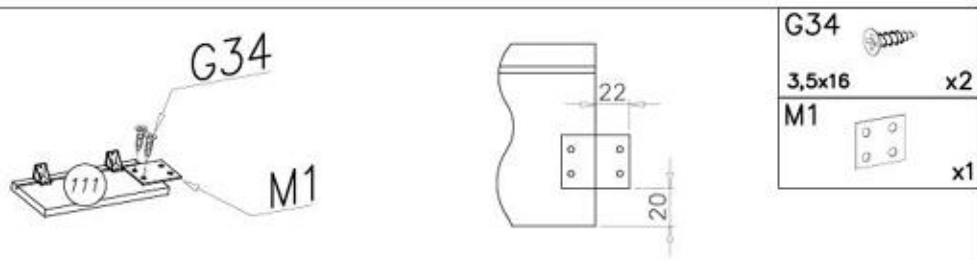

10/21

LANDHAUS 22



XII

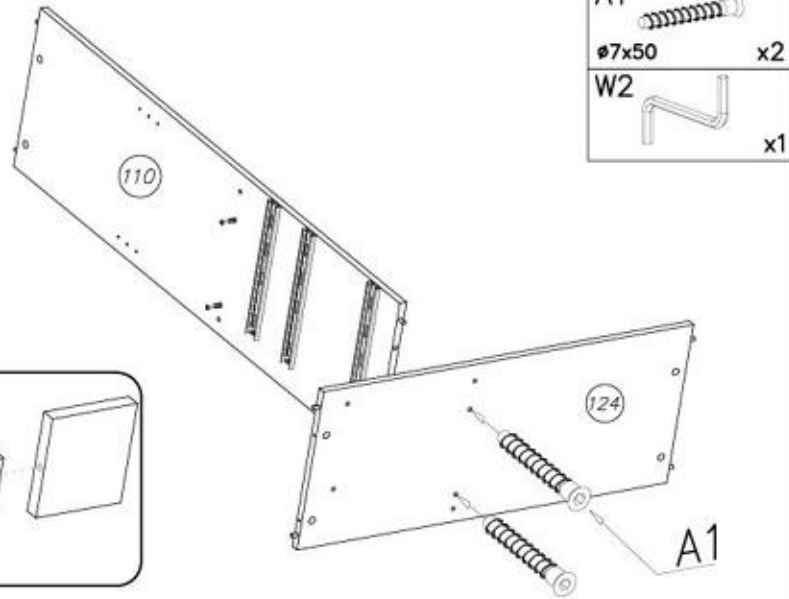

11/21

LANDHAUS 22



XIV

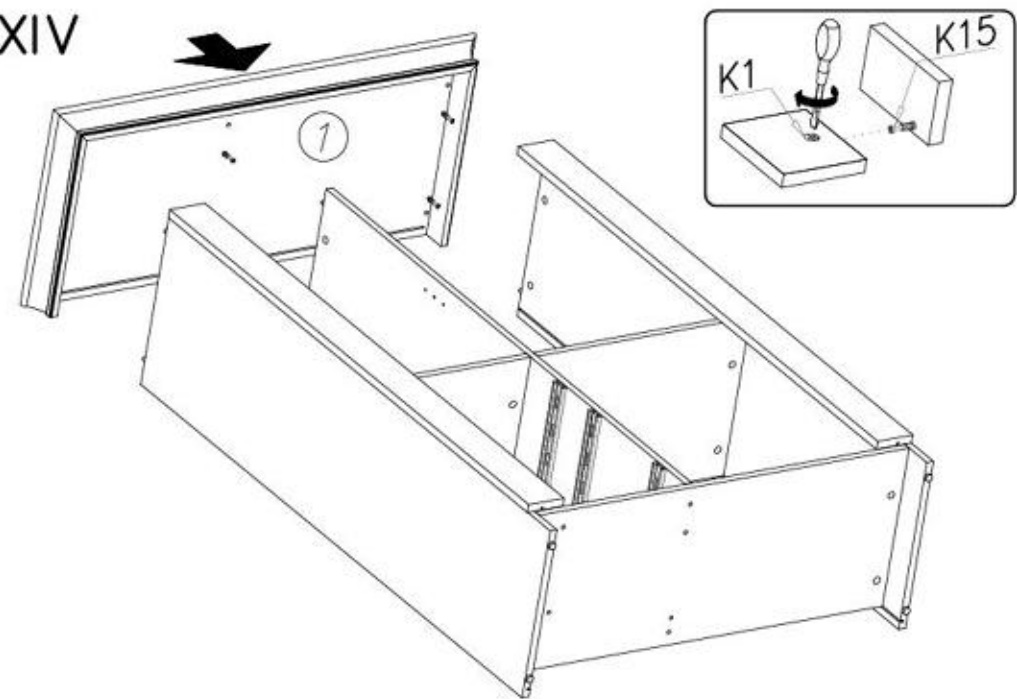

XIII

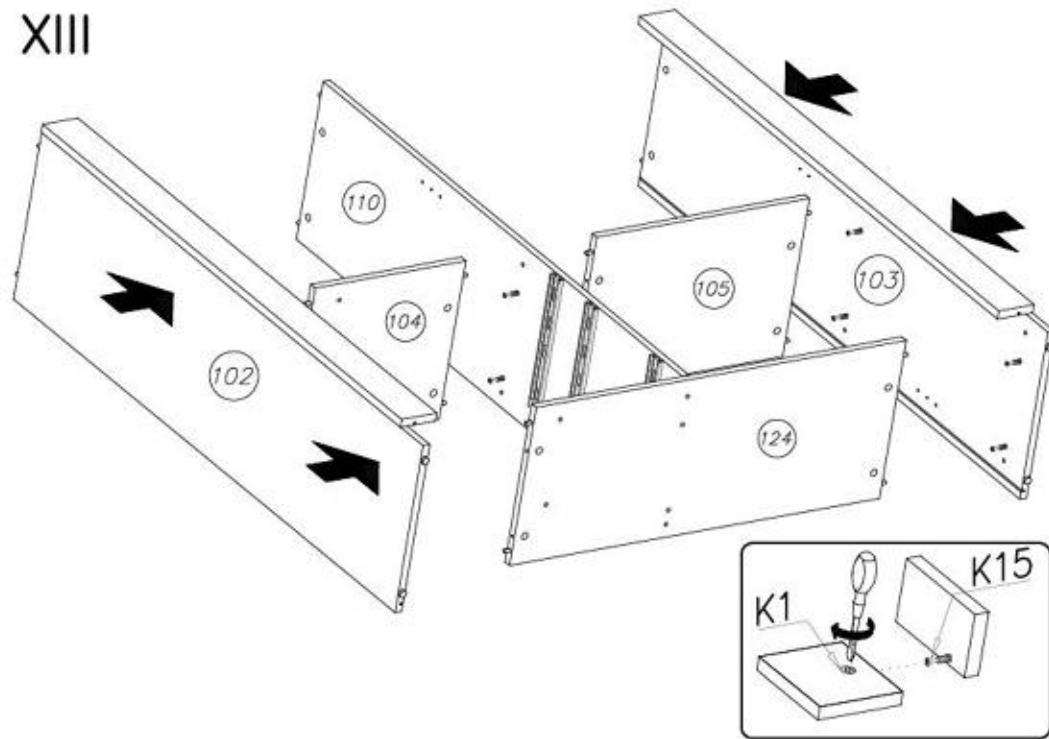

XV

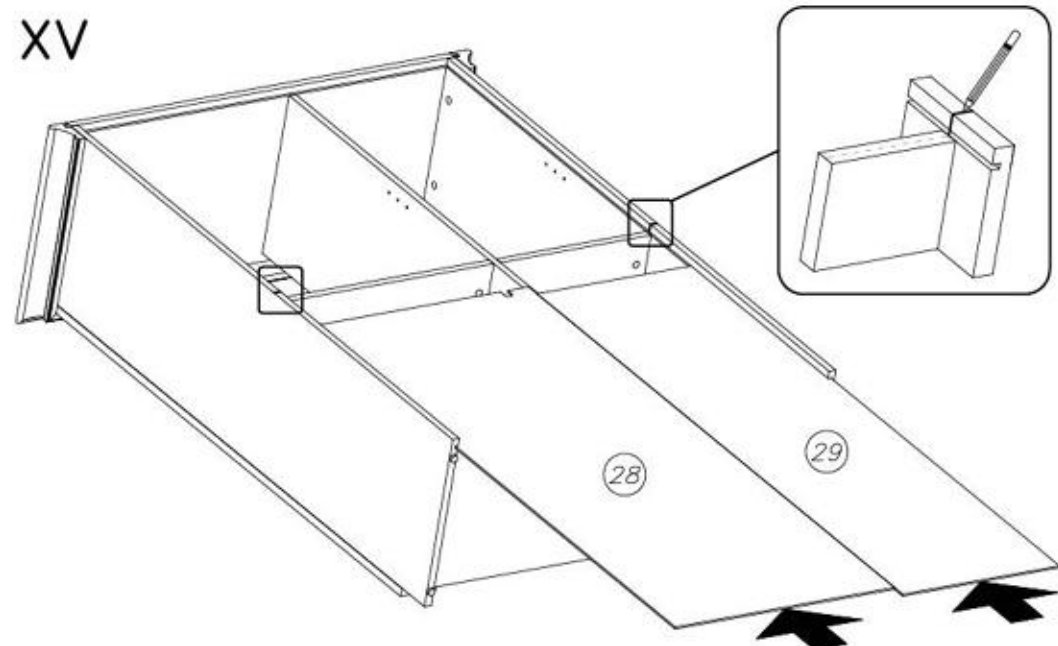

12/21

LANDHAUS 22



XVI

P27



x1

S2



x12

I1



x12

G34



3,5x16

x36

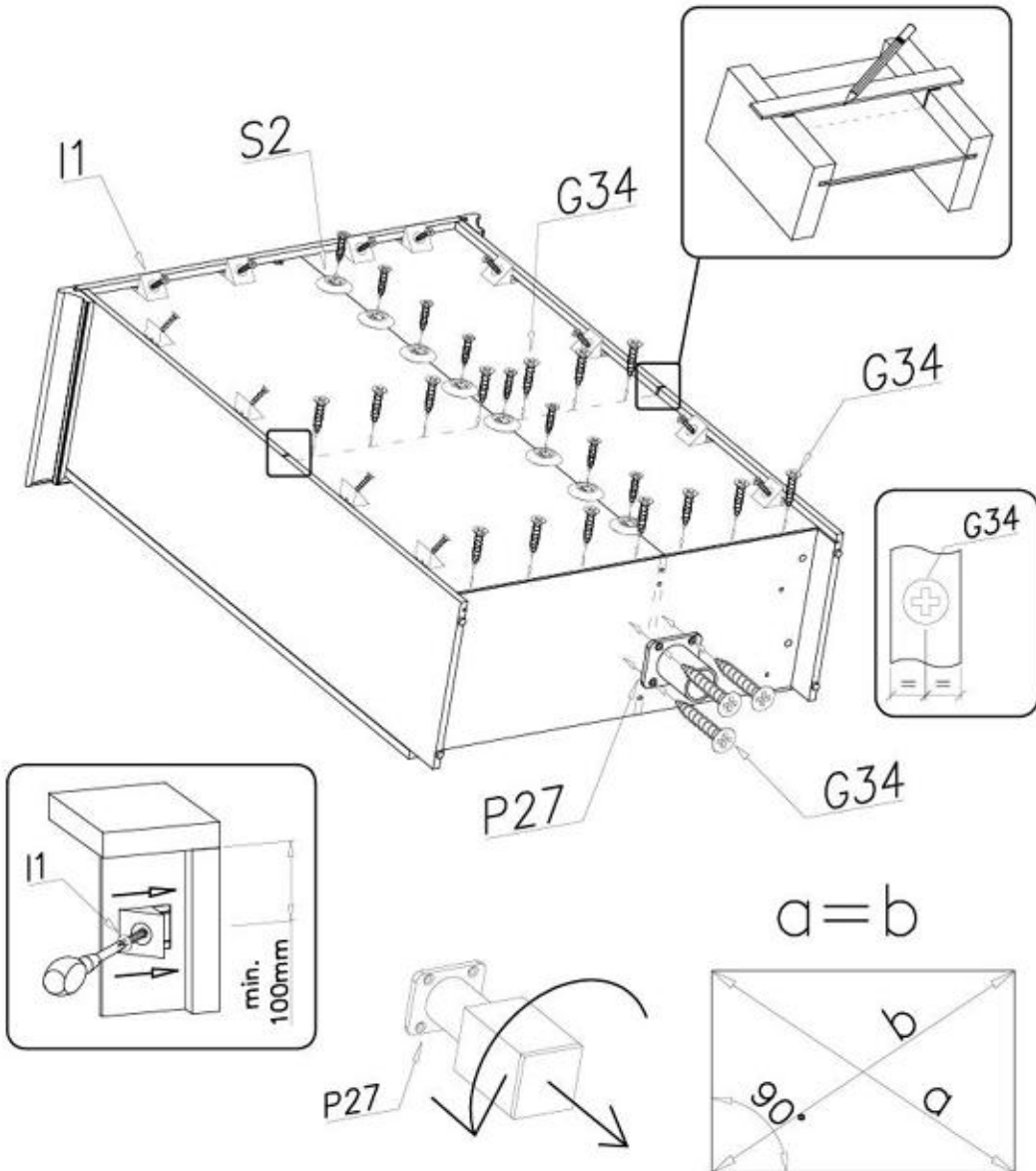

13/21

LANDHAUS 22



XVII

P27



x1

P27

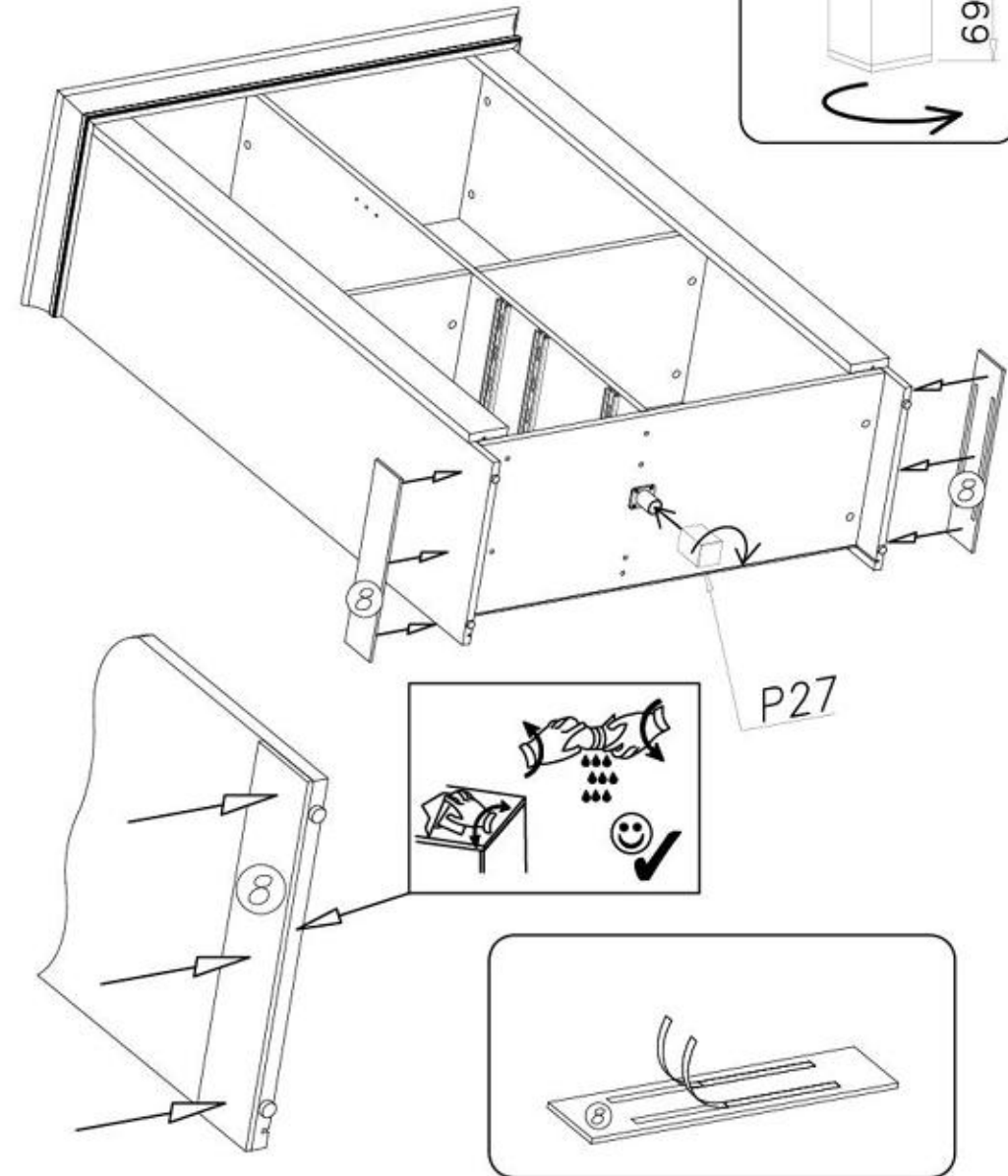
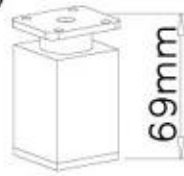

14/21

LANDHAUS 22



XVIII

1

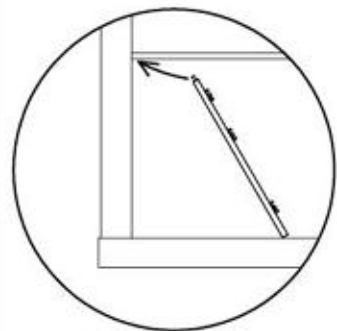

2

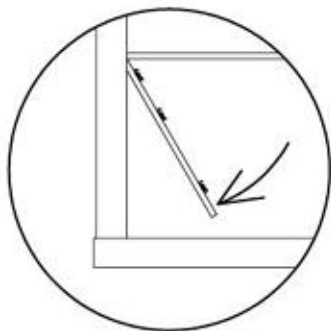

3

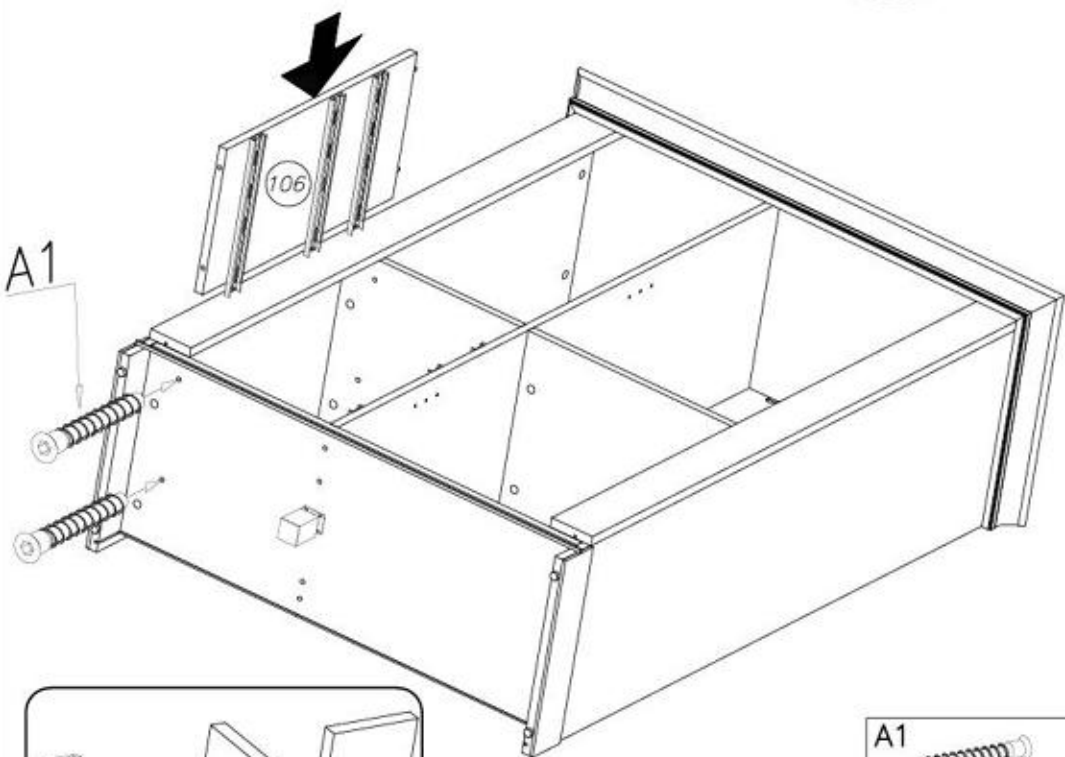
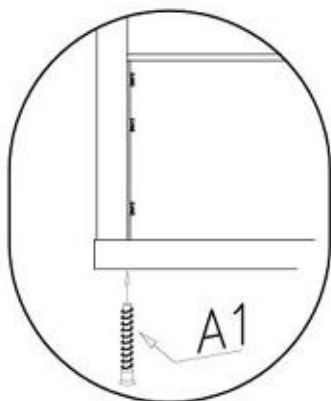

A1

Ø7x50

x4

W2

x1

15/21

LANDHAUS 22



XIX

G56

4x16

x6

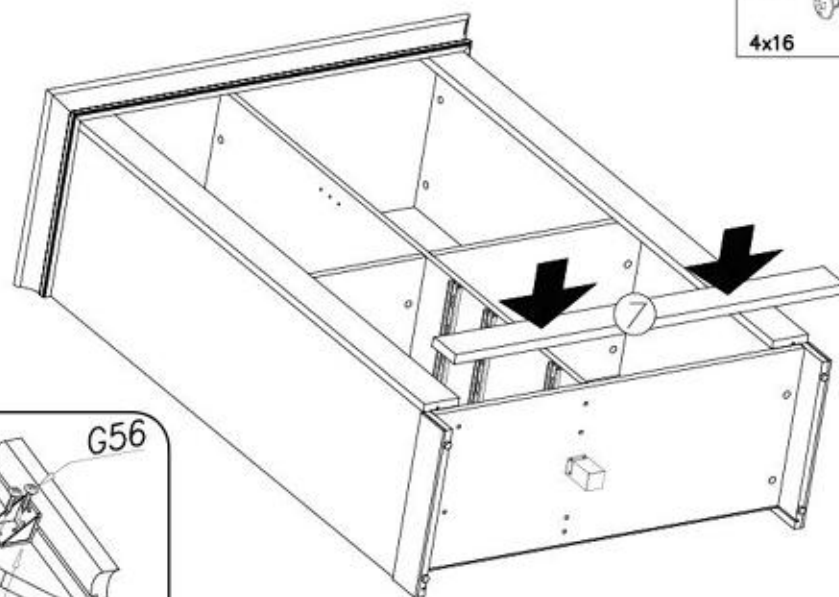

F12

G56

XX

G56

4x16

x4

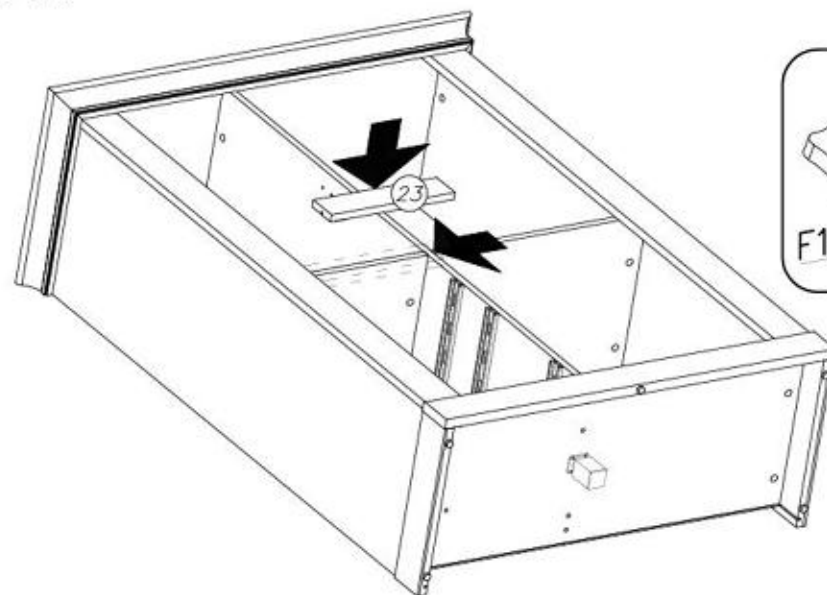

F12

G56

16/21

LANDHAUS 22



XXI

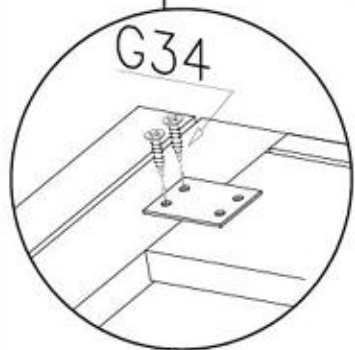
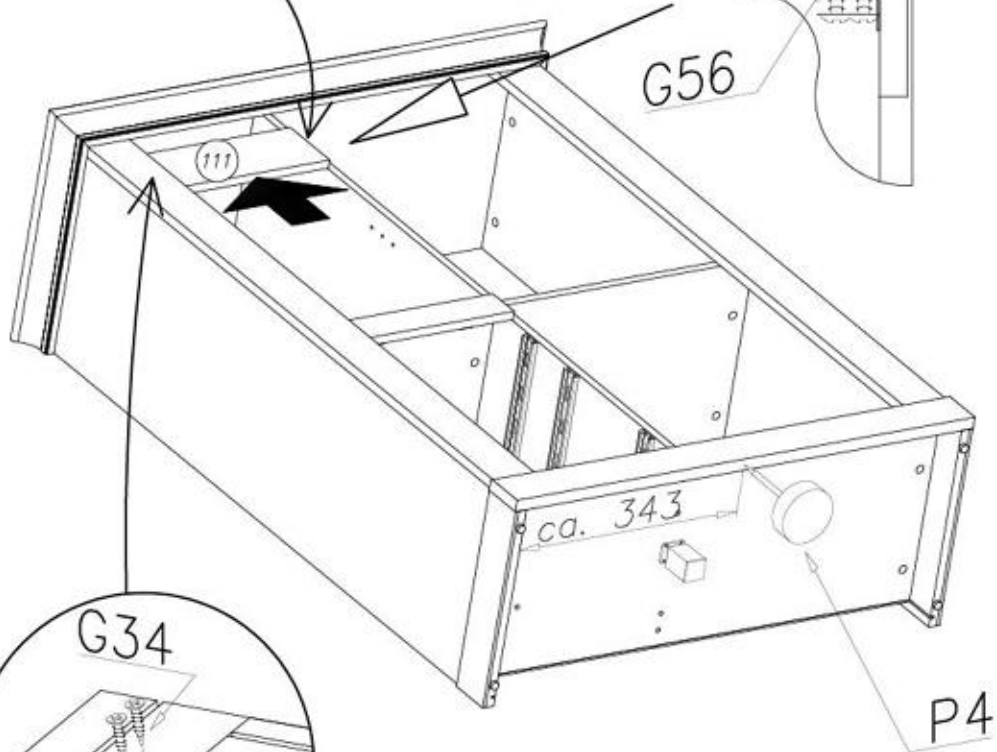
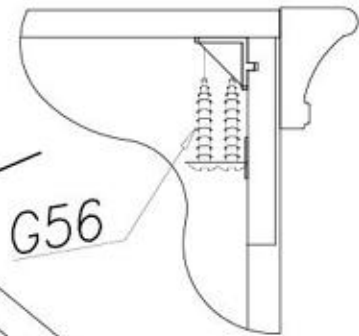
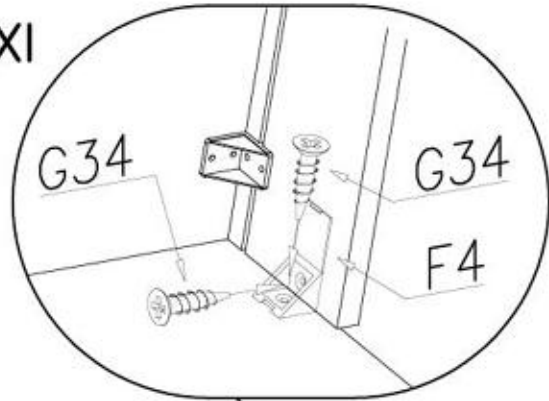
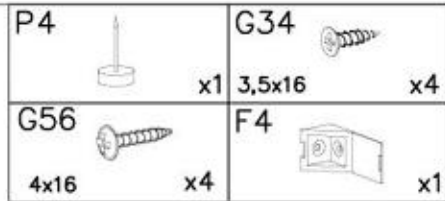

17/21

LANDHAUS 22



XXII

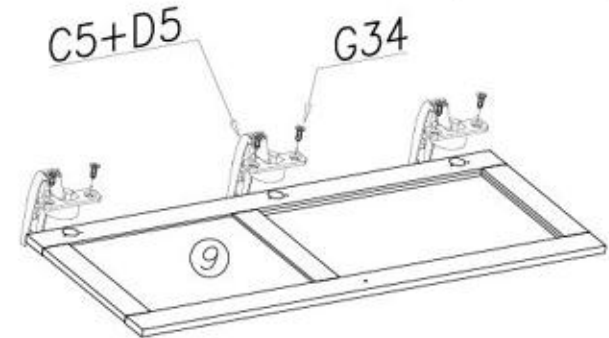
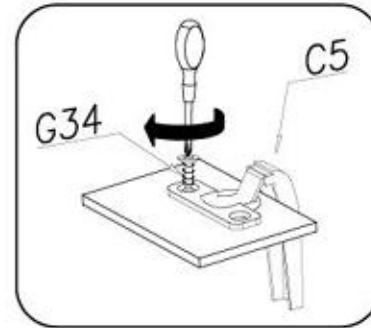
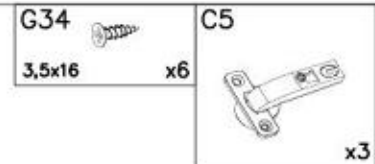

XXIII

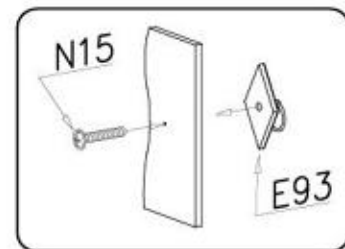
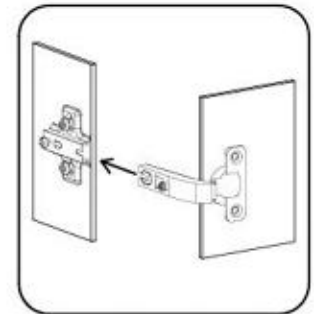
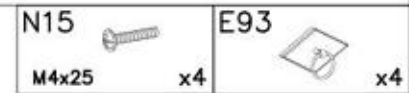



XXIV

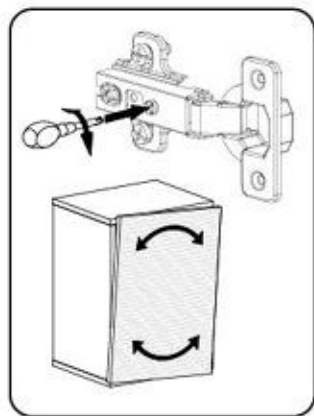
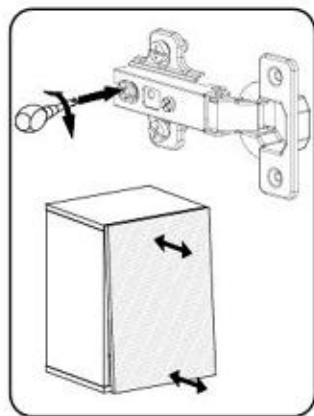
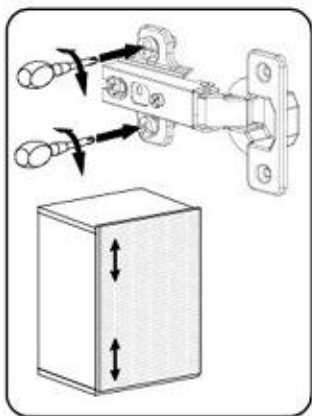
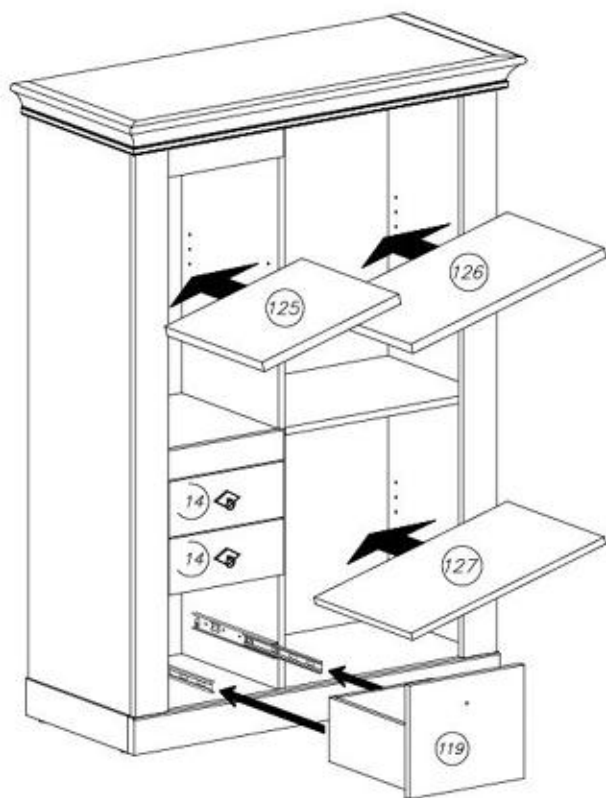

XV

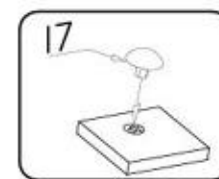
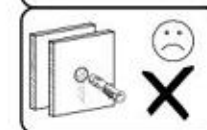
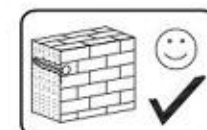
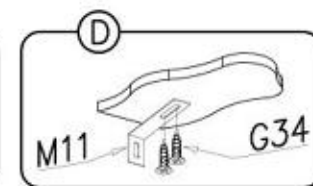
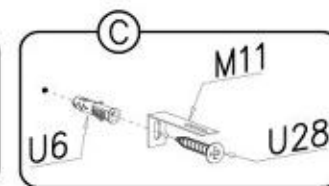
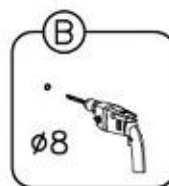
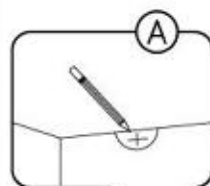
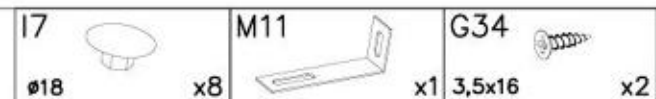

LANDHAUS

22

D Unser Direktservice für Beschädigte
Sollte Ihnen ein Beschädigter Schaden, können Sie diese Servicekarte direkt an die unversehrte Nummer senden. Wir können allerdings nur Beschädigte auf diesem Weg verschicken. Sollen Sie eine andere Beanstandung an Ihrem Möbelstück haben, so wenden Sie sich bitte direkt an Ihr Möbelhaus.

GB Our direct order service for fitting
If a fitting should be missing to you, you know this service card directly following number boxes, we can in this way send away however only fitting. If you should have another objection to your piece of furniture, then they turn please to your furniture house.

CZ Naše přímá služba pro školení
Čtyři číselníky a 1 kování, můžete tuto službu využít pouze tehdy pokud máte nějakou vadu. Pokud máte nějakou jinou vadu, obraťte se přímo na svého prodejce nábytku.

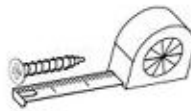

F Bien étudier le notice de montage
Après les pièces correspondantes vous meubles. Répétez et contrôler le qu'il faut. Ensuite - vous de l'assemblage nécessaires. Aménager - vous une zone de montage. Procédez au montage. Ne jamais forcer les assemblages. Remarque: les vis sont quelques temps d'usage. Garder votre notice de montage, si une pièce venait à manquer, elle serait le plus sûr moyen de communiquer avec votre magasin.

I Il nostro servizio diretto per l'ordine delle forniture
In caso di mancanza di una parte, potete spedire fax questa carta di servizio direttamente al seguente numero. Per altri problemi al vostro mobile, potete rivolgervi al vostro mobilificio.

BG Директно обслужаване при повреждение
Ако имате повреждение на мебел, можете да изпратите директно тази карта за поръчка на частите. Можем да ви предоставим само частите. Ако имате друг проблем с мебел, моля да се свържете директно с вашия магазин.

NL Onze directservice voor lokale onderdelen
Wanneer er een onderdeel mist kunt u deze servicekaart direct aan onderdelen bezorgers sturen. Wij kunnen alleen langa deze weg onderdelen verschaffen. Mocht u een ander probleem aan uw meubel hebben, verzoeken wij u contact op te nemen met uw meubelbedrijf.

PL Należy bezpośrednio serwis części montażowych
Jeżeli brakuje części koniecznych do montażu, prosimy o przesłanie nam tej karty serwisowej na niżej podany numer faxu. Materiały w ten sposób przysyłane będą tylko niezbędne części. W przypadku innych problemów dotyczących mebli, prosimy o bezpośredni kontakt do salonu meblowego w którym został dokonany zakup.

HR Servis za dijelove
U slučaju da nedostaje neki od dijelova meblu, možete nam ovaj servisni karticu poslati direktno na ovaj broj pozivanja ovog servisa. Na ovaj način mogu se dostaviti samo dijelovi. U slučaju da imate dodatne prigovore vezane uz komad namještaja, molimo vas da se obratite izravno trgovini namještaja gdje je isti kupljen.

HU Direktáruszállású részletek esetén
Ha hiányzik egy részlet, ezt a felhívást közvetlenül a részletekért az alábbi telefonszáma felé kell elküldeni. Csak az alábbi részletek tudunk így szállítani. Amennyiben másféle reklamációt áll fel balesetmentesítés, forduljon közvetlenül a boltjához.

SK Naše priamo servis pro školenie
Ak by Vám chýbalo nejaké súčiastky, môžete poslať túto servisnú kartu priamo priamo na nižšie uvedené číslo s fax. Táto služba je určená výhradne pre školenie. Ak by ste mali iný problém s nábytkom, obráťte sa priamo na Vašu predajňu nábytku.

SLO Naše direktno službo strahovno za dijelove
Če vam manjka kakikoli delov, lahko to servisu kartico pošljete po faxu direktno na spodnje število. Po tej poti vam lahko pošljemo samo dijelove. Če imate kakikoli drugi problem, se obrnite neposredno na vašo trgovino poharbo.

RO Servis-ul nostru direct pentru furneturile
In cazul in care va lipseste o piesa de mobilier, puteti sa trimiti direct acest card de service pe fax la numarul de mai jos. Noi nu putem furniza piese de mobilier decât pe acest fel de card. Servis-ul este destinat referentelor la piese de mobilier, atunci va rugam să va adresati direct la magazinul dvs. de mobilă.

RUS Наш прямой сервис для поставки фурнитуры
Если окажется, что Вам не хватает той или иной детали фурнитуры, Вы можете отправить сервисную карту по факсу непосредственно на нижеприведенный номер. Однако, только по этому каналу мы можем предоставлять лишь фурнитуру. Если же у Вас возникнут иные претензии относительно приобретенной мебели, пожалуйста, обращайтесь непосредственно в организационно-сервисный отдел.

S Vår direktservice för beskadigade
Om du skickar en beskadigad karta till följande servicekort direkt till nummer som anges ned. Då kan vi skicka till dig den enda möjligheten att skicka beskadigade till dig. Om du vill reklamera din möbel är en annan anledning tillika du kontakta ditt möbelhus direkt.

ES Nuestro servicio directo para averías
Si le falta algún accesorio, puede enviar esta tarjeta de servicio directamente a la siguiente dirección. No obstante, por esta vía sólo podemos enviar accesorios. Si tiene alguna otra objeción sobre su mueble, consulte directamente con su mueblera.

TR Doğrudan için doğrudan servisi
Bir eşyanın aksesuarı ya da servisi için doğrudan eşyanın bulunduğu adrese doğrudan mail gönderilebilir. Ancak bu yolla doğrudan gönderilebilir. Mobilyanızla ilgili diğer sorularınız varsa lütfen doğrudan mobilya satışınıza danışın.

			G56		4x16	x...
F4		A1		M1		x...
W1		N15		E93		x...
W2		G20		F2		x...
H23		I7		M11		x...
H35=300mm		I1		P4		x...
B1		G34		F12		x...
A6		C5+D5		P27		x...
K1		K15				x...
S2						x...

+49 5233 95 290 10

service@imv-steinheim.de

LANDHAUS

22

D Unser Direktservice für Beschädigte
Sollte Ihnen ein Beschädigter Schaden, können Sie diese Servicekarte direkt an die unversehrte Nummer senden. Wir können allerdings nur Beschädigte auf diesem Weg verschicken. Sollen Sie eine andere Beanstandung an Ihrem Möbelstück haben, so wenden Sie sich bitte direkt an Ihr Möbelhaus.

GB Our direct order service for fitting
If a fitting should be missing to you, you know this service card directly following number boxes, we can in this way send away however only fitting. If you should have another objection to your piece of furniture, then they turn please to your furniture house.

CZ Naše přímá služba pro školení
Čtyři číselníky a 1 kování, můžete tuto službu využít pouze tehdy pokud máte nějakou vadu. Pokud máte nějakou jinou vadu, obraťte se přímo na svého prodejce nábytku.

F Bien étudier le notice de montage
Après les pièces correspondantes vous meubles. Répétez et contrôler le qu'il faut. Ensuite - vous de l'assemblage nécessaires. Aménager - vous une zone de montage. Procédez au montage. Ne jamais forcer les assemblages. Remarque: les vis sont quelques temps d'usage. Garder votre notice de montage, si une pièce venait à manquer, elle serait le plus sûr moyen de communiquer avec votre magasin.

I Il nostro servizio diretto per l'ordine delle forniture
In caso di mancanza di una parte, potete spedire fax questa carta di servizio direttamente al seguente numero. Per altri problemi al vostro mobile, potete rivolgervi al vostro mobilificio.

BG Директно обслужаване при повреждение
Ако имате повреждение на мебел, можете да изпратите директно тази карта за поръчка на частите. Можем да ви предоставим само частите. Ако имате друг проблем с мебел, моля да се свържете директно с вашия магазин.

NL Onze directservice voor lokale onderdelen
Wanneer er een onderdeel mist kunt u deze servicekaart direct aan onderdelen bezorgers sturen. Wij kunnen alleen langa deze weg onderdelen verschaffen. Mocht u een ander probleem aan uw meubel hebben, verzoeken wij u contact op te nemen met uw meubelbedrijf.

PL Należy bezpośrednio serwis części montażowych
Jeżeli brakuje części koniecznych do montażu, prosimy o przesłanie nam tej karty serwisowej na niżej podany numer faxu. Materiały w ten sposób przysyłane będą tylko niezbędne części. W przypadku innych problemów dotyczących mebli, prosimy o bezpośredni kontakt do salonu meblowego w którym został dokonany zakup.

HR Servis za dijelove
U slučaju da nedostaje neki od dijelova meblu, možete nam ovaj servisni karticu poslati direktno na ovaj broj pozivanja ovog servisa. Na ovaj način mogu se dostaviti samo dijelovi. U slučaju da imate dodatne prigovore vezane uz komad namještaja, molimo vas da se obratite izravno trgovini namještaja gdje je isti kupljen.

HU Direktáruszállású részletek esetén
Ha hiányzik egy részlet, ezt a felhívást közvetlenül a részletekért az alábbi telefonszáma felé kell elküldeni. Csak az alábbi részletek tudunk így szállítani. Amennyiben másféle reklamációt áll fel balesetmentesítés, forduljon közvetlenül a boltjához.

SK Naše priamo servis pro školenie
Ak by Vám chýbalo nejaké súčiastky, môžete poslať túto servisnú kartu priamo priamo na nižšie uvedené číslo s fax. Táto služba je určená výhradne pre školenie. Ak by ste mali iný problém s nábytkom, obráťte sa priamo na Vašu predajňu nábytku.

SLO Naše direktno službo strahovno za dijelove
Če vam manjka kakikoli delov, lahko to servisu kartico pošljete po faxu direktno na spodnje število. Po tej poti vam lahko pošljemo samo dijelove. Če imate kakikoli drugi problem, se obrnite neposredno na vašo trgovino poharbo.

RO Servis-ul nostru direct pentru furneturile
In cazul in care va lipseste o piesa de mobilier, puteti sa trimiti direct acest card de service pe fax la numarul de mai jos. Noi nu putem furniza piese de mobilier decât pe acest fel de card. Servis-ul este destinat referentelor la piese de mobilier, atunci va rugam să va adresati direct la magazinul dvs. de mobilă.

RUS Наш прямой сервис для поставки фурнитуры
Если окажется, что Вам не хватает той или иной детали фурнитуры, Вы можете отправить сервисную карту по факсу непосредственно на нижеприведенный номер. Однако, только по этому каналу мы можем предоставлять лишь фурнитуру. Если же у Вас возникнут иные претензии относительно приобретенной мебели, пожалуйста, обращайтесь непосредственно в организационно-сервисный отдел.

S Vår direktservice för beskadigade
Om du skickar en beskadigad karta till följande servicekort direkt till nummer som anges ned. Då kan vi skicka till dig den enda möjligheten att skicka beskadigade till dig. Om du vill reklamera din möbel är en annan anledning tillika du kontakta ditt möbelhus direkt.

ES Nuestro servicio directo para averías
Si le falta algún accesorio, puede enviar esta tarjeta de servicio directamente a la siguiente dirección. No obstante, por esta vía sólo podemos enviar accesorios. Si tiene alguna otra objeción sobre su mueble, consulte directamente con su mueblera.

TR Doğrudan için doğrudan servisi
Bir eşyanın aksesuarı ya da servisi için doğrudan eşyanın bulunduğu adrese doğrudan mail gönderilebilir. Ancak bu yolla doğrudan gönderilebilir. Mobilyanızla ilgili diğer sorularınız varsa lütfen doğrudan mobilya satışınıza danışın.

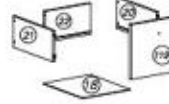
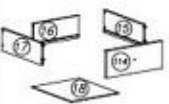
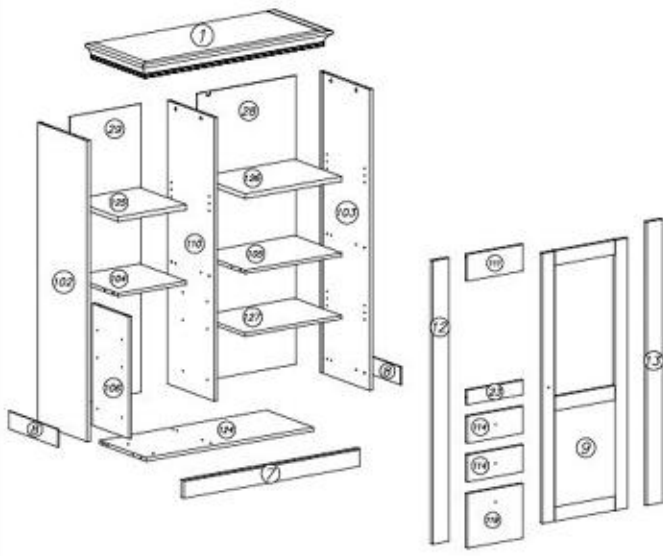

nr	[mm]	[mm]	[mm]	menge	cat
1	1017	439	70	2/2	
2	111	298	120	16	1/2
3	123	1263	85	18	1/2
4	104	364	356	16	2/2
5	114	295	122	16	2/2
6	106	553	278	16	2/2
7	8	940	80	22	2/2
8	17	300	100	12	2/2
9	18	376	80	6	1/2
10	9	1223	454	18	1/2

nr	[mm]	[mm]	[mm]	menge	cat
11	20	300	140	12	1/2
12	21	300	140	12	1/2
13	22	241	140	12	1/2
14	23	298	65	16	2/2
15	124	894	356	16	2/2
16	125	364	351	22	2/2
17	127	514	351	16	2/2
18	28	1306	530	3	1/2
19	29	1306	378	3	1/2

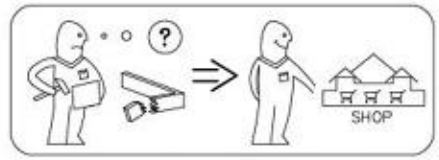



- Ⓛ Montageanleitung
- Ⓝ Handleiding voor de montage
- Ⓜ Montaj talimatı
- Ⓧ Notice de montage
- Ⓢ Montážní návod
- Ⓡ Szereelési útmutató
- Ⓚ Assembly Instructions
- Ⓟ Instrukcja montażu
- ⓇⓇ Инструкция по монтажу
- Ⓡ Istruzioni di montaggio
- Ⓢ Návod na montáž
- Ⓡ Instrucțiuni de montaj
- Ⓧ Instrucciones de montaje
- Ⓜ Montaj Talimatı

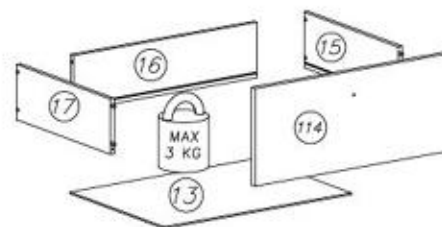
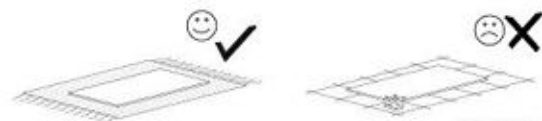
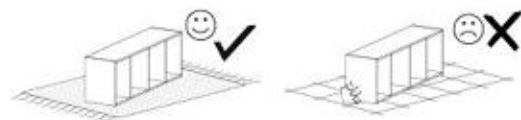
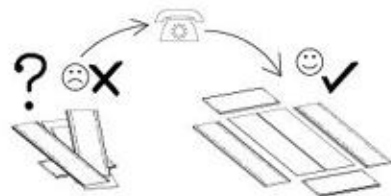
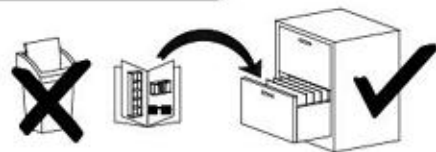
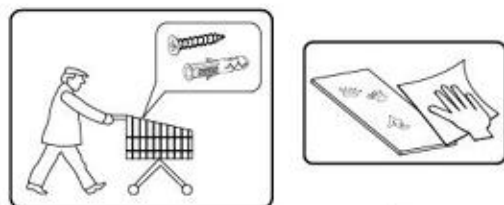
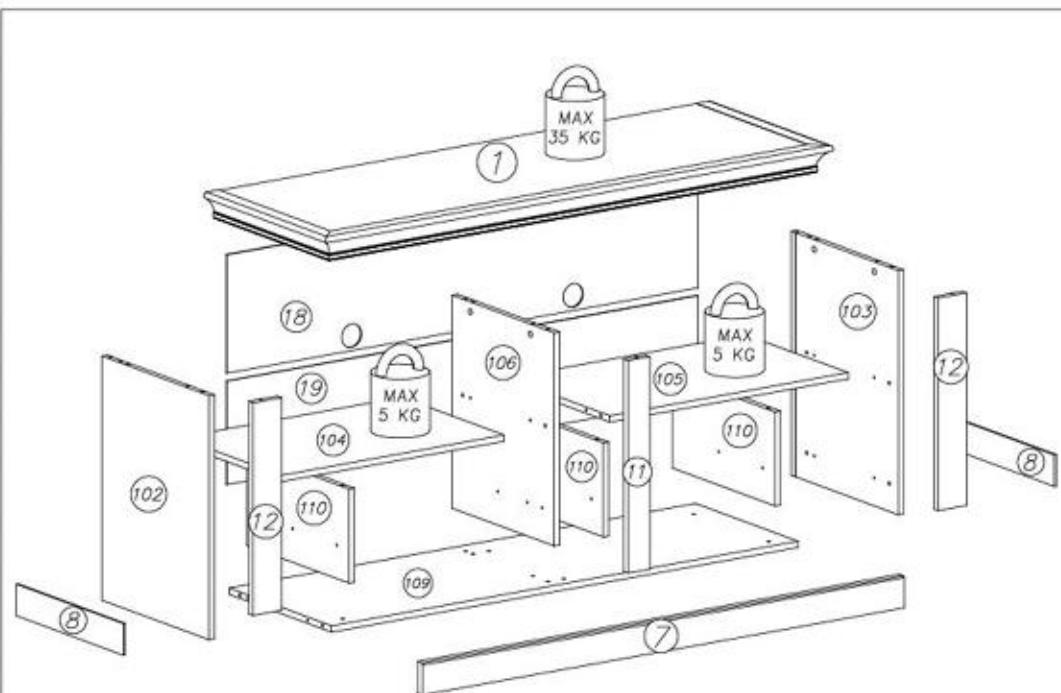

nr	L[mm]	B[mm]	T[mm]	Menge	Coll
1	1514	519	70	1	2/2
102	618	456	16	1	2/2
103	618	456	16	1	2/2
104	664	436	16	1	2/2
105	711	436	16	1	2/2
106	539	436	16	1	2/2
7	1438	80	22	1	1/2
8	456	80	6	2	1/2
109	1391	436	16	1	1/2
110	238	436	16	3	2/2
11	538	65	18	1	2/2
12	538	85	18	2	1/2
13	557	401	3	1	2/2
114	589	247	16	2	1/2
15	400	140	12	2	1/2
16	547	140	12	2	1/2
17	400	140	12	2	1/2
18	1403	299	3	1	1/2
19	1403	262	3	1	1/2

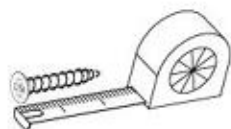
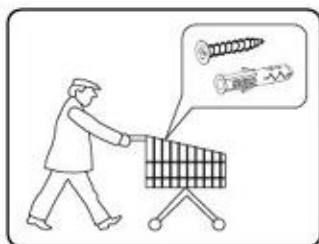

G56
4x16 x44

A1 Ø7x50 x8	W1 GLUE, LEIM, LEPIDLO, LIM x2	N15 M4x25 x2	E93 x2
S2 x13	W2 x1	G20 5x13 x16	P27 x1
A6 Ø7x40 x8	H24 H35-400mm x2	I7 Ø18 x18	M11 x1
K1 Ø15x12 x18	I1 x8	P4 x5	
K15 x18	B1 Ø8x35 x26	G34 3,5x16 x36	F12 x11

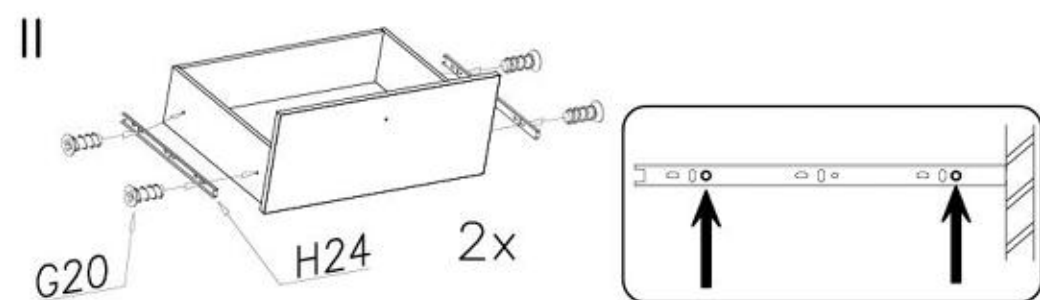
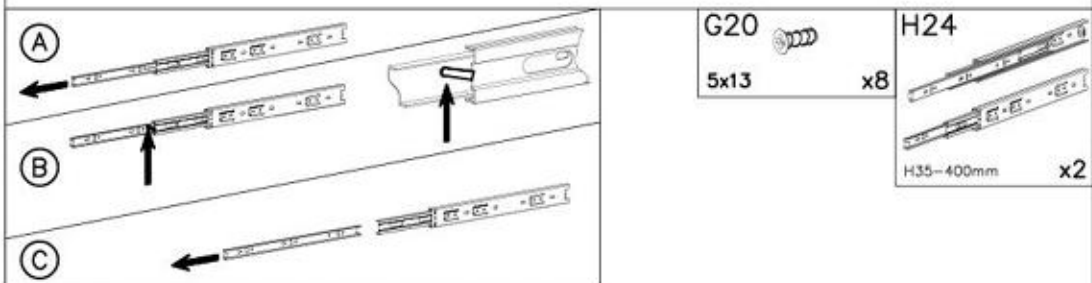
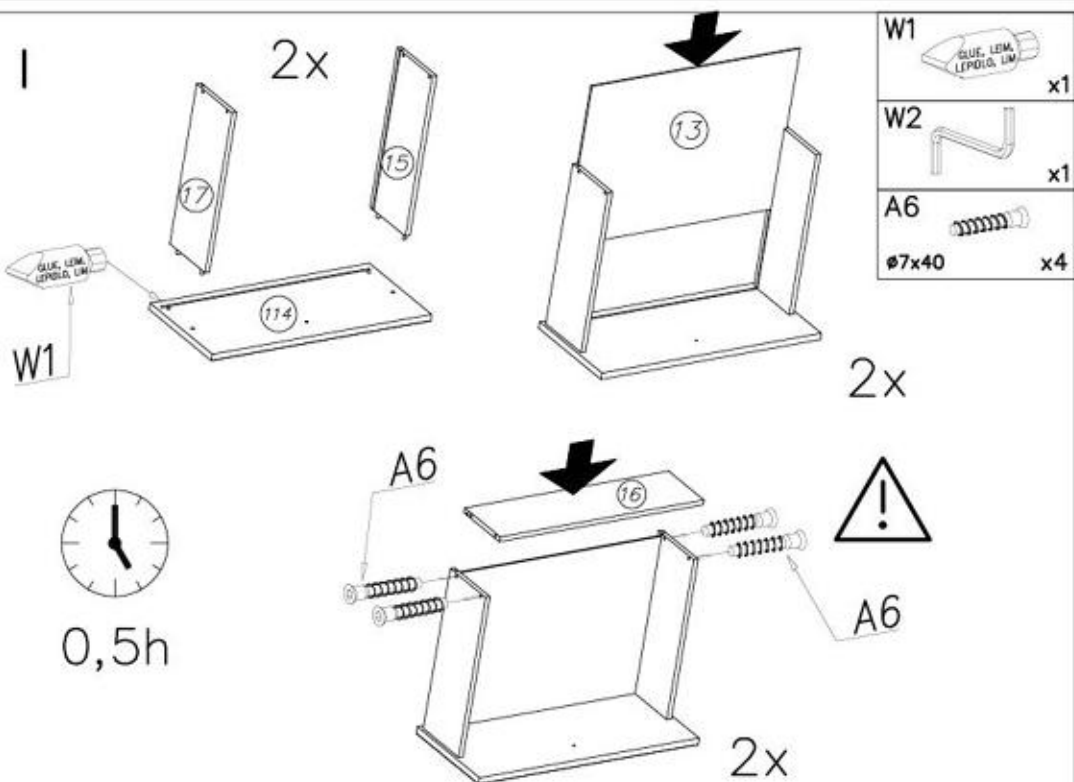

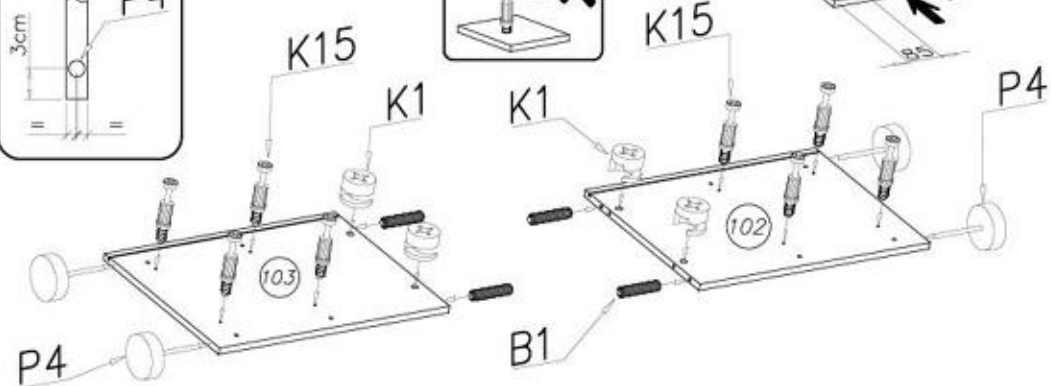
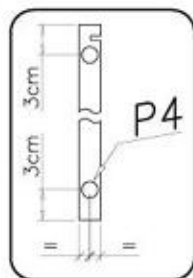
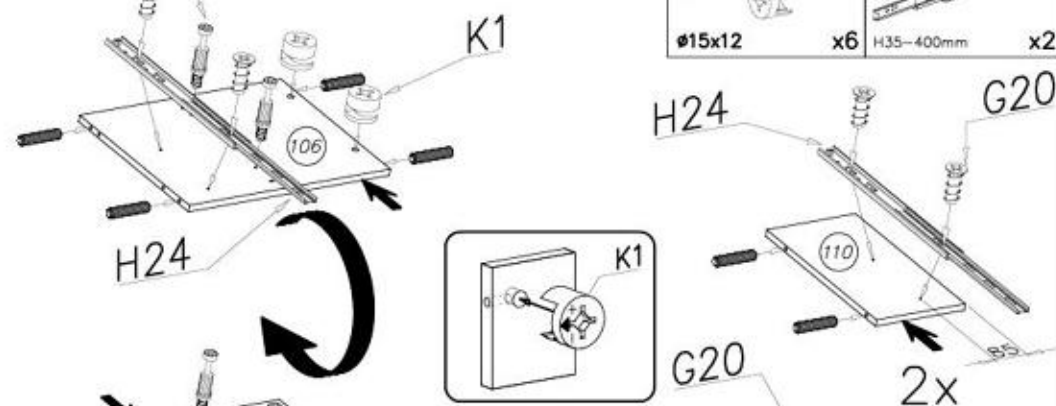
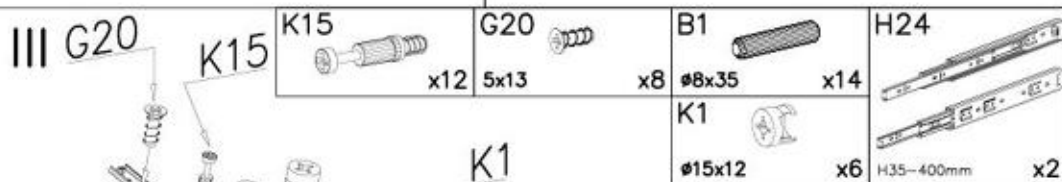
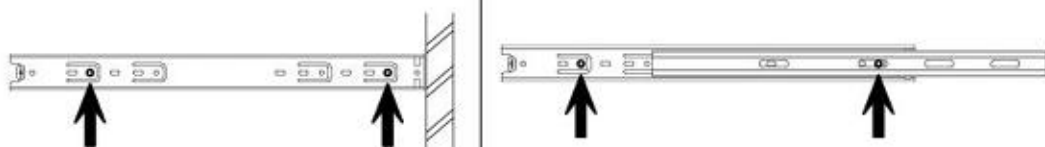

IV

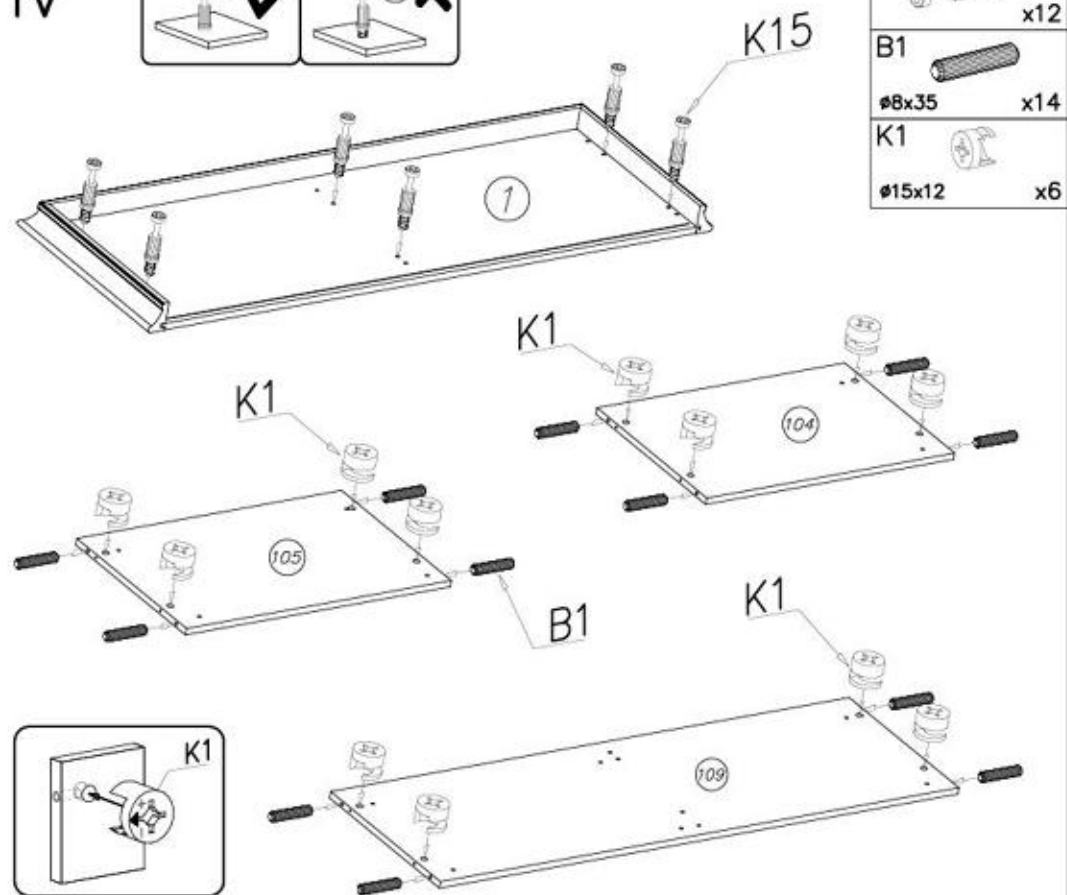
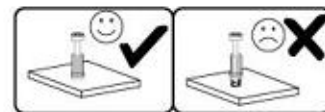

V

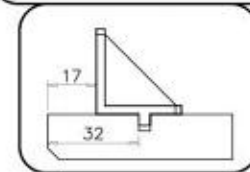
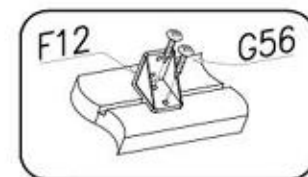
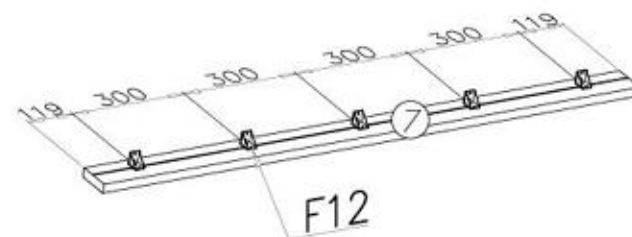
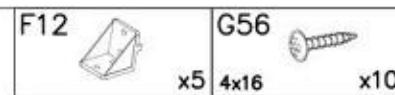

7/17

LANDHAUS 32



VI

F12



x6

G56



4x16

x12

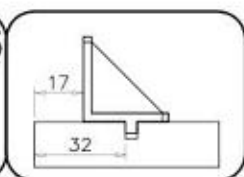
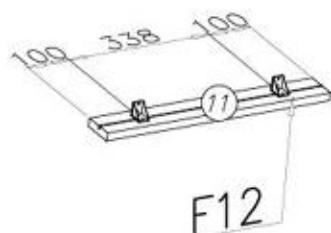
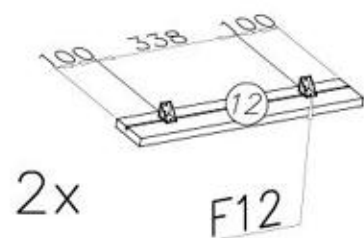

VII

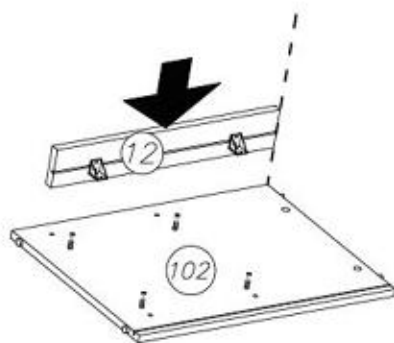

G56



4x16

x8

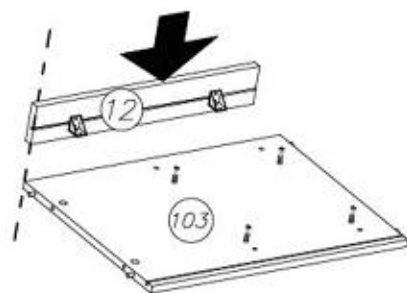
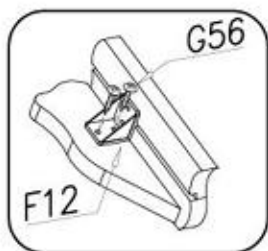

8/17

LANDHAUS 32



VIII

A1

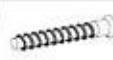

ø7x50

x2

W2



x1

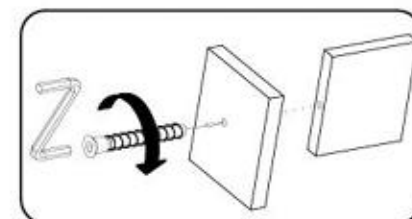
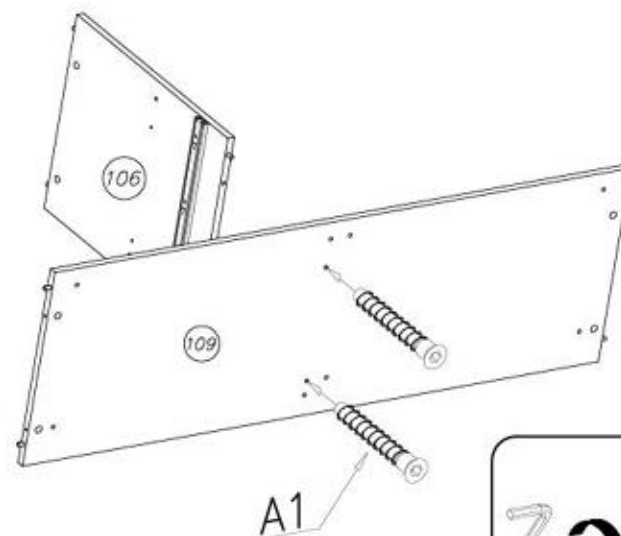

IX

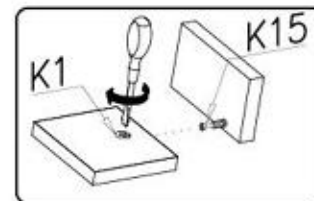
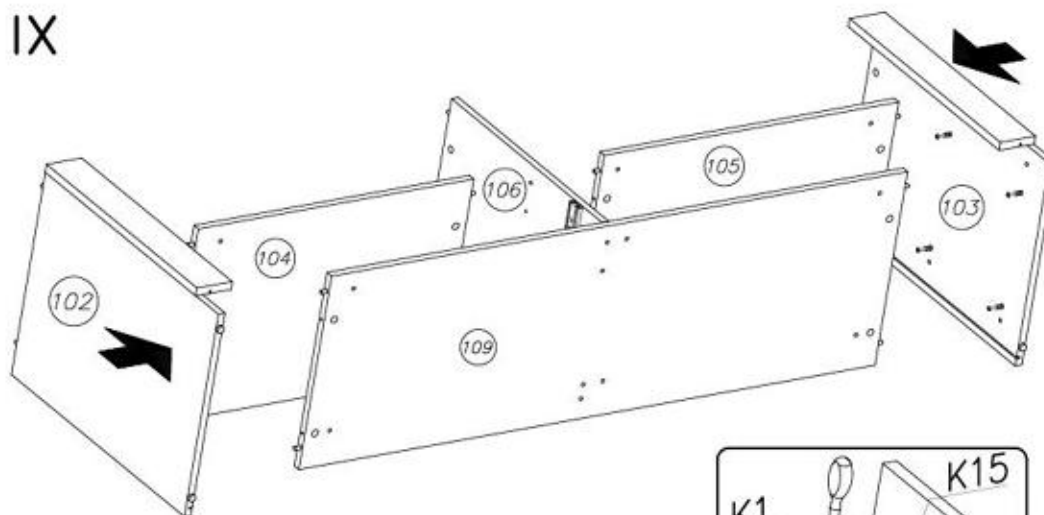

9/17

LANDHAUS 32



X

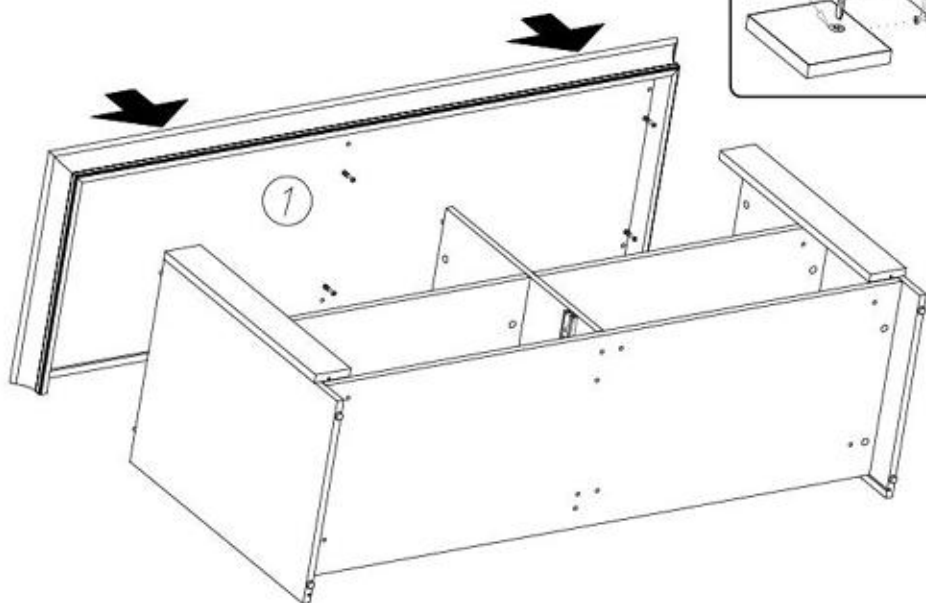

XI

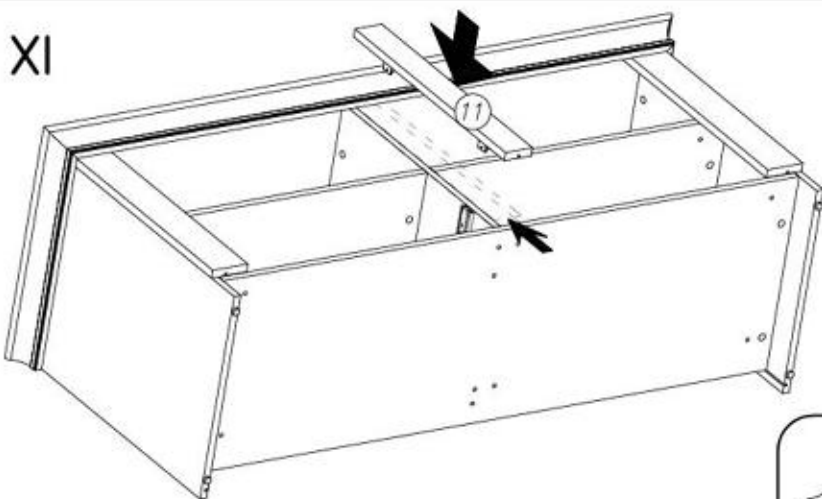

G56
4x16 x4

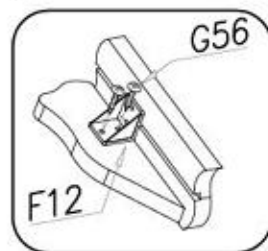

10/17

LANDHAUS 32



XII

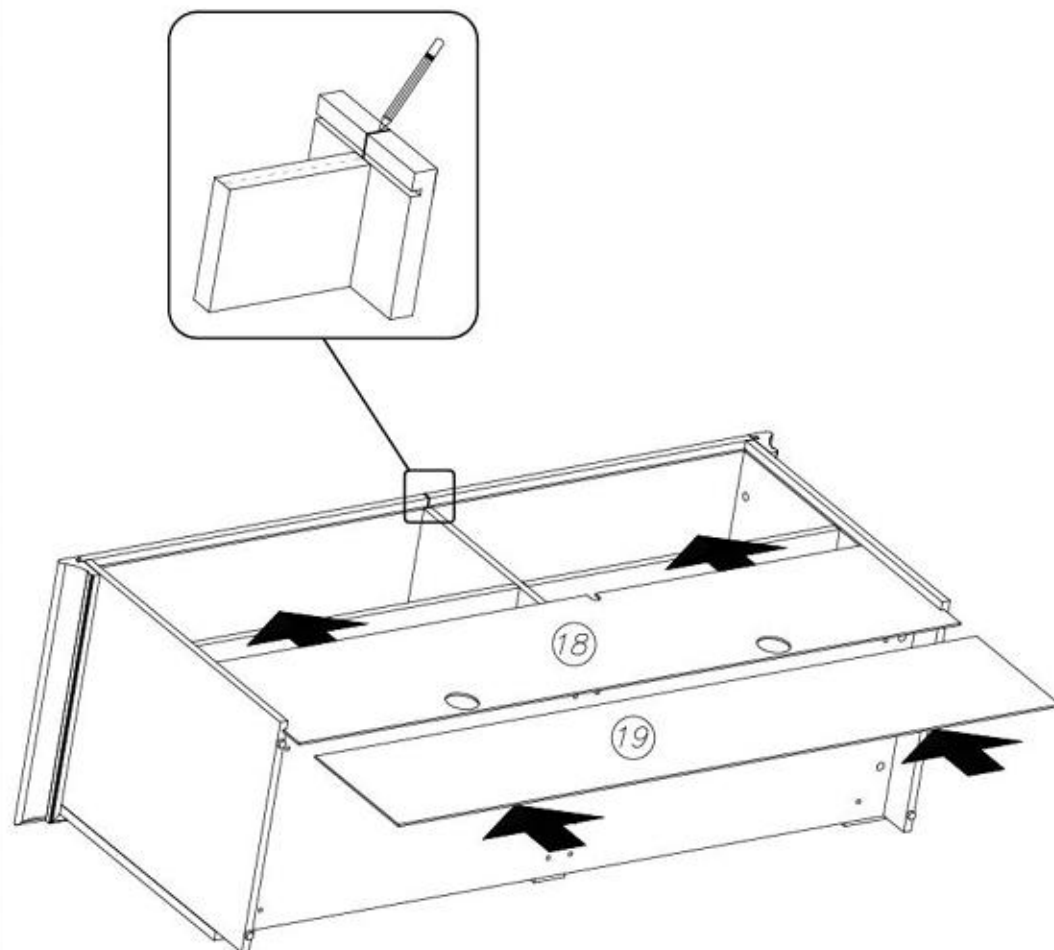



XIII

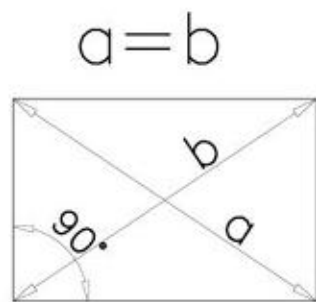
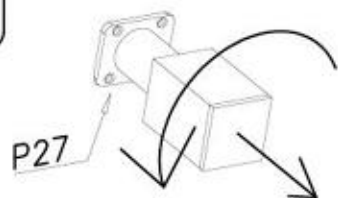
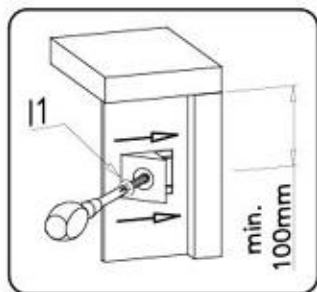
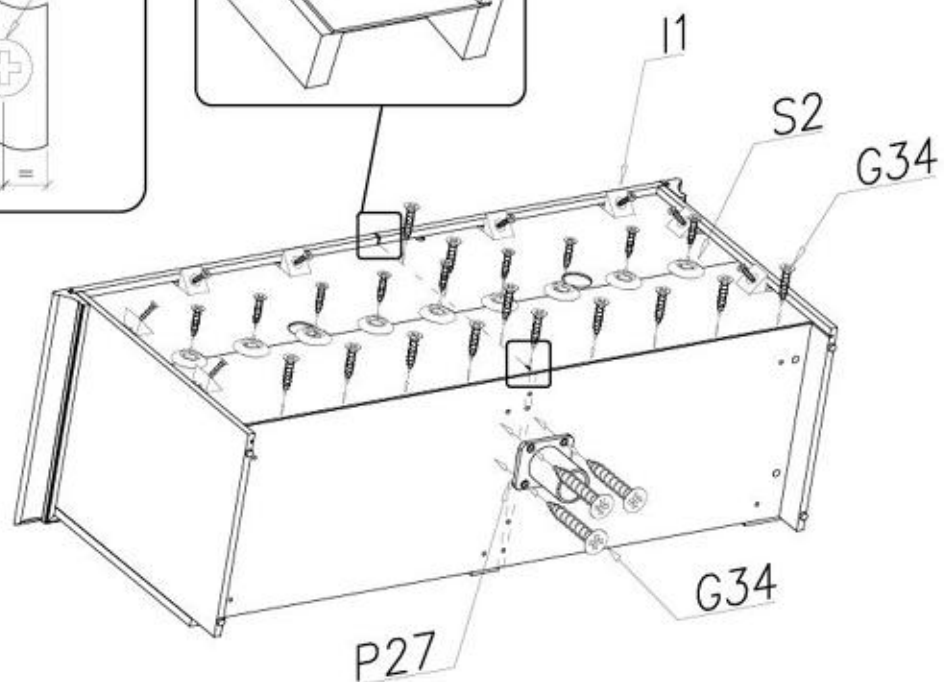
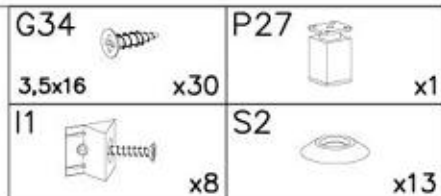
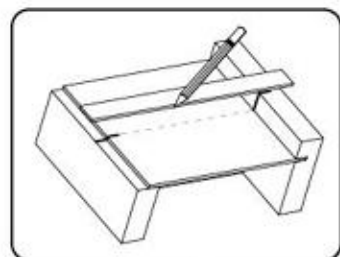
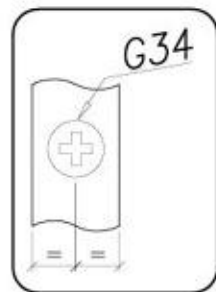

XIV

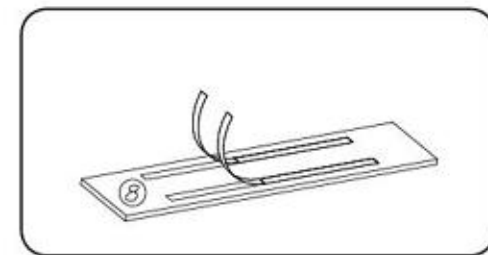
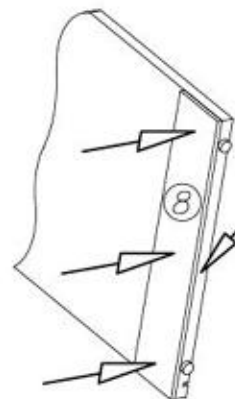
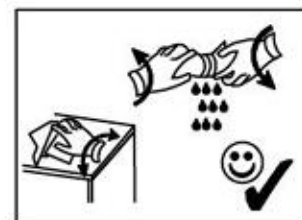
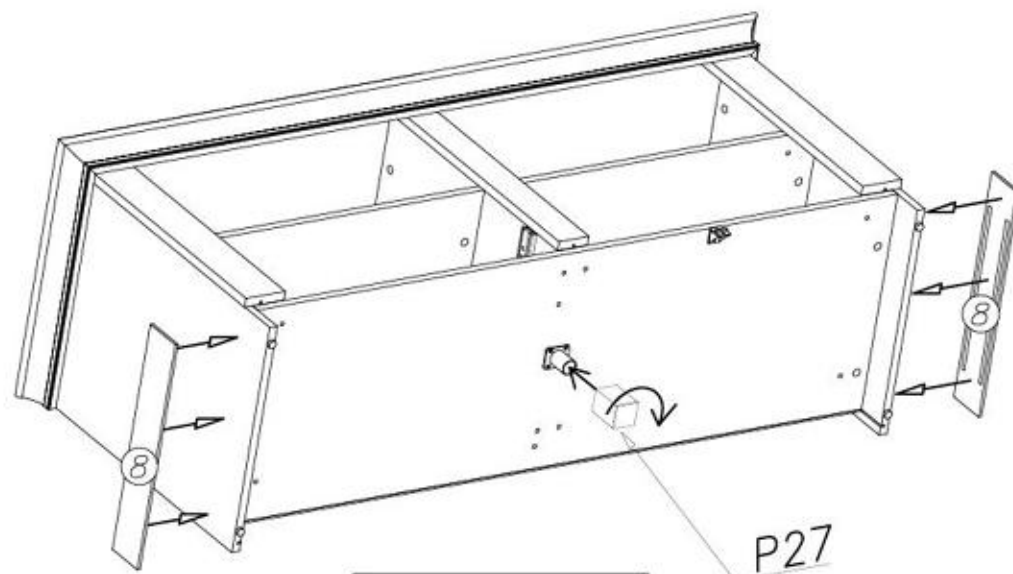
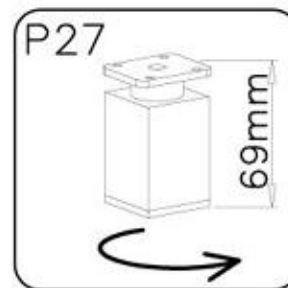



XV

1

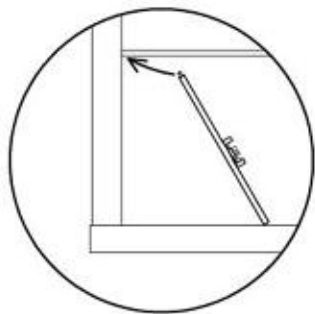

2

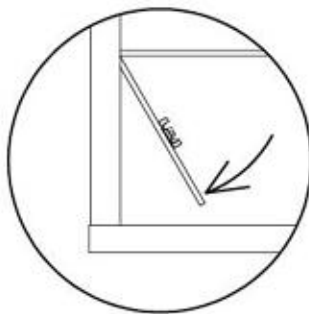

3

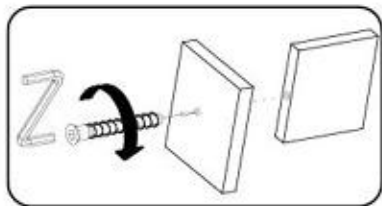
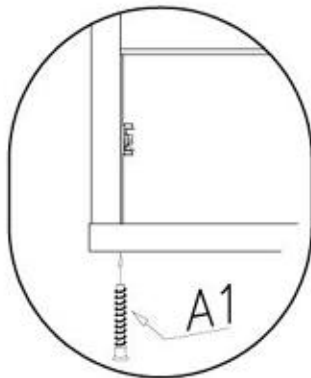

x1

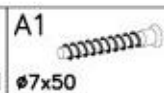

x6

A1

x6

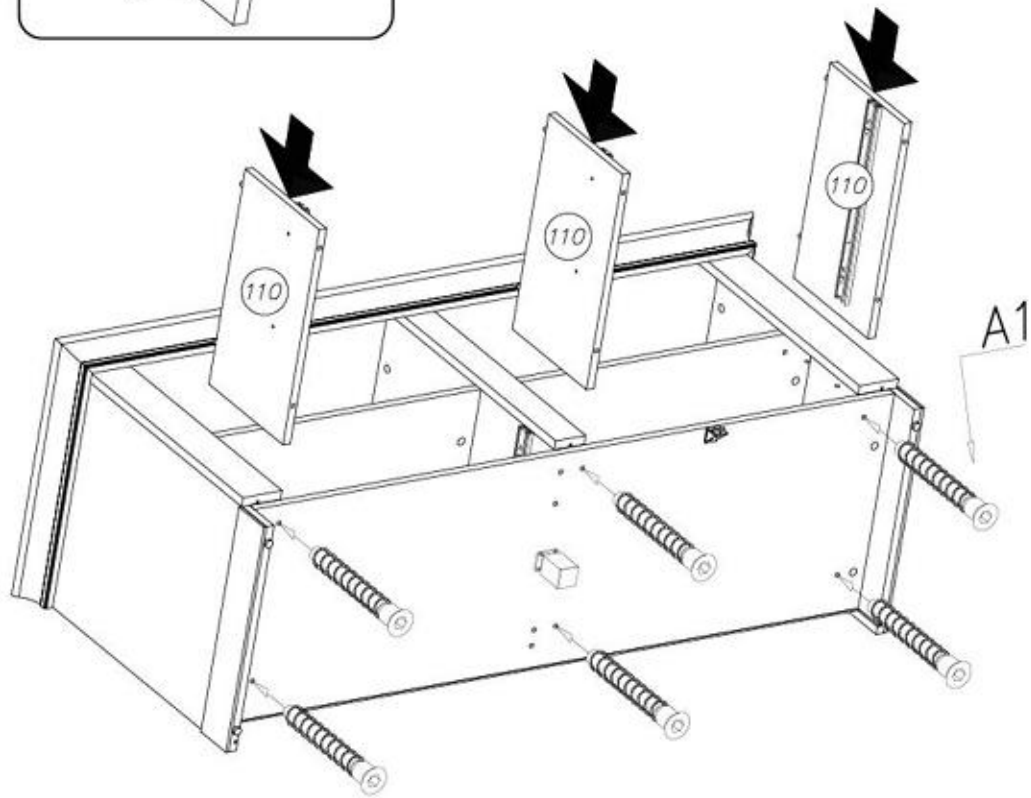

XVI

G56



4x16

x10

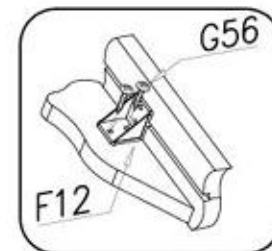
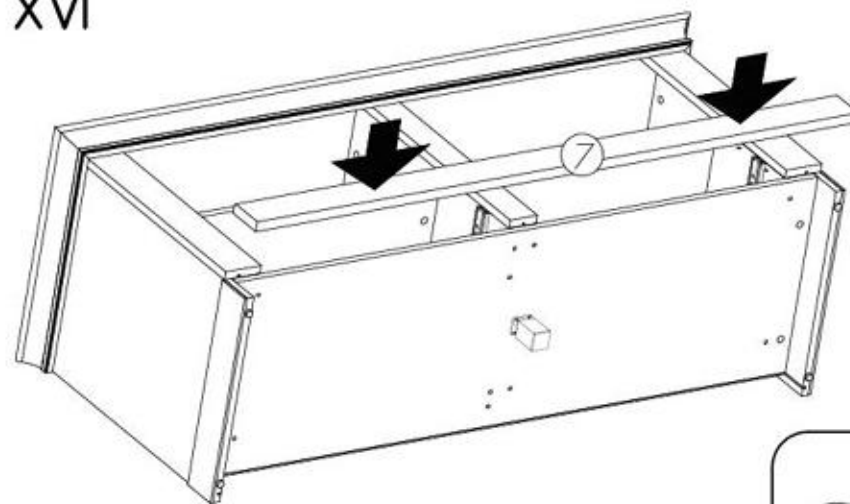

XVII

P4



x1

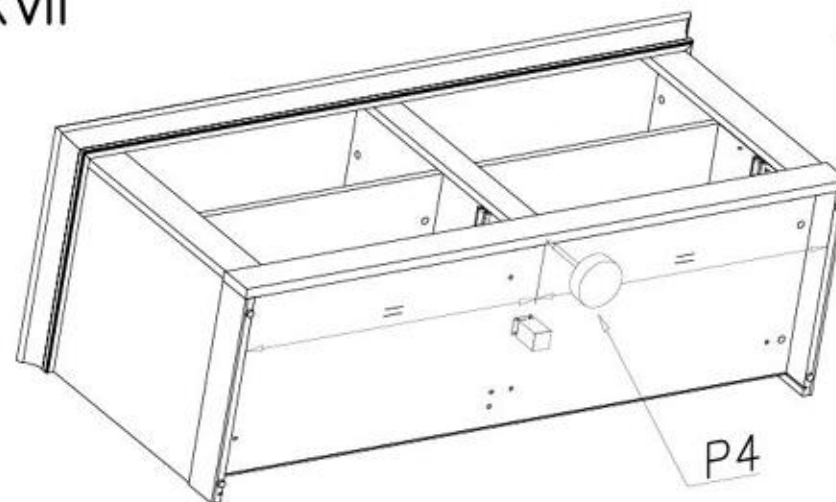



N15 M4x25 x2	E93 x2	I7 ø18 x18	M11 x1	G34 3,5x16 x2
--------------------	-----------	------------------	-----------	---------------------

XVIII

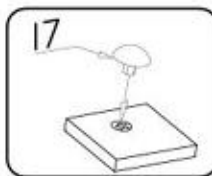
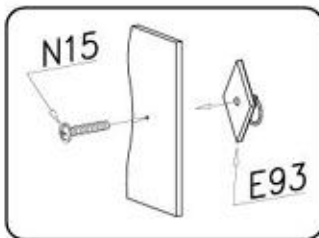
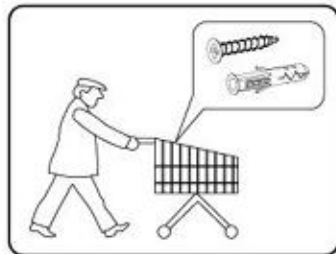
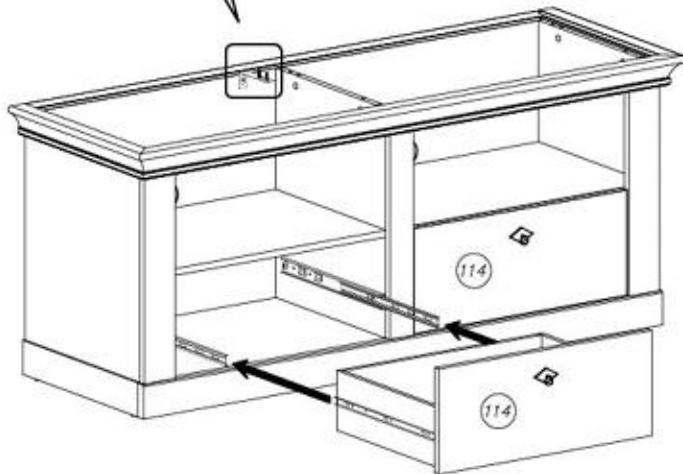
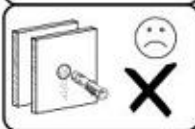
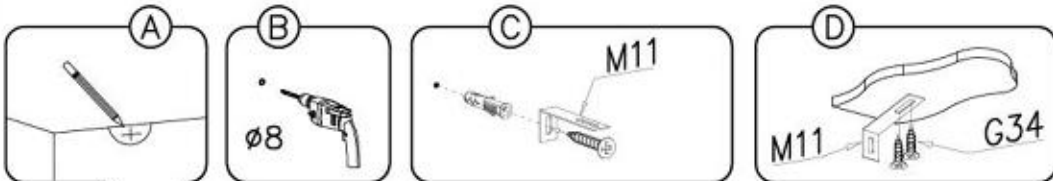

Name • Nom • Nome • Naom • Nazwa • Jméno • Νόζov • Νέv • Denumire • Isim • И́звaние	Nr • No • N° • Номер • Č • Sz	Typ • Type • Tip • Típus • Típo • Tun
LANDHAUS	--	32

D Unser Dienstservice für Beschädigte
 Sollte Ihnen ein Beschädigter fallen, können Sie diese Servicekarte direkt an die unterstehende Nummer senden. Wir können allerdings nur Beschädigte auf diesem Weg verschicken. Sollen Sie eine andere Beanstandung an Ihrem Möbelstück haben, so wenden Sie sich bitte direkt an Ihr Möbelhaus.

GB Our direct order service for fitting
 If a fitting should be missing to you, you know this service card directly following number boxes, you can in this way send away however only fitting. If you should have another objection to your piece of furniture, then they turn please to your furniture house.

CZ Nežte přímé služby pro kování
 Když-li vám nějaký díl z kování, můžete tuto službu kartou odeslat přímo na níže uvedenou adresu. Tuto službu však můžeme poskytnout jen díky kování. Pokud byste měli nějaký jiný problém, obraťte se přímo na svého prodejce nábytku.

F Nosre service direct pour l'entretien de la menuiserie
 Si vous avez un problème de menuiserie, vous pouvez envoyer cette carte de service directement à l'adresse indiquée. Nous ne pouvons cependant intervenir que pour les problèmes de menuiserie. Pour tout autre problème, veuillez vous adresser à votre magasin.

I Il nostro servizio diretto per l'ordine delle forniture
 Nel caso di mancanza del pezzo, potete spedire fax questa carta di servizio direttamente al seguente numero. Per altri problemi al vostro mobile, potete rivolgervi al vostro mobilista.

BG Издигно обслужаване на повреден обзект
 Ако имате повреден обзект, можете да изпратите тази карта за директен поръчка на адреса, който е посочен на картата. Можем да предоставим услуги само за повреди на обзекта. За всички други проблеми, моля, обърнете се директно към вашия магазин.

NL Onze directservice voor beschadigingen
 Wanneer er een onderdeel mist komt u deze servicekaart direct aan onderstaand telefoonnummer. Wij kunnen alleen fax deze kaart weg verzenden voorstellen. Mocht u een ander probleem aan uw meubel hebben, verzoeken wij u contact op te nemen met uw meubelwiel.

PL Nasz bezpośredni serwis części montażowych
 Jeżeli brakuje części koniecznych do montażu, prosimy o przesłanie nam tej karty serwisowej na niżej podany numer faxu. Materiały w ten sposób przysyłane będą tylko w przypadku uszkodzeń. W przypadku innych ewentualnych doległości, prosimy o skierowanie ich do naszego meblowego w którym został dokonany zakup.

HR Servis za dijelove
 U slučaju da nedostaje neki od dijelova molimo vas da na ovoj kartici obavijestite naš broj poslovanja ovaj servis obrascem. Na ovaj način mogu se dostaviti samo dijelovi. U slučaju da imate dodatne prigovore vezane uz komad namještaja molimo vas da se obratite izravno trgovini namještaja gdje ste ih kupili.

HU Díszolgáltatásunk sérült részre
 Ha sérült részre van szükség, ezt a kártyát közvetlenül a felsorolt címre küldheti meg. Csak a kártyán keresztül tudunk szolgáltatást nyújtani. Minden egyéb problémát, kérjük, forduljon közvetlenül a boltunkhoz.

SK Naše priamo služby pre škodenie
 Ak by Vám chýbala niekajá časť, môžete poslať túto službu kartu priamo na nižšie uvedenú adresu. Táto služba sa poskytuje iba v prípade škodení. Všetky ostatné problémy, prosíme, aby ste mali na mysli náš predajcu nábytku.

SLO Naše direktno službe za škodila
 Če vam manjka kakikoli delov, lahko to storimo kartico pošljete po faxu direktno na spodnjo številko. Po tej poti vam lahko pošljemo samo delovce. Če imate kakikoli drugo težavo, se obrnite neposredno na vašo trgovino pohištva.

RO Servisul nostru direct pentru repararea
 În cazul în care vă lipsește o piesă de mobilier, puteți să trimiteți direct această card de servis pe fax la numărul de mai jos. Noi nu putem accepta plase de mobilier decât pe această cale. Dacă aveți o altă reclamație referitoare la piesa de mobilier, atunci vă rugăm să vă adresați direct la magazinul dvs. de mobilă.

RUS Наш прямой сервис для устранения повреждений
 Если поврежден какой-либо элемент мебели, вы можете отправить сервисную карту по факсу непосредственно на нижеприведенный номер. Однако, только по почте мы можем предоставлять услуги по ремонту. Если у вас возникли иные претензии относительно приобретения мебели, пожалуйста, обращайтесь непосредственно в организацию, осуществляющую продажу.

S Vår direkte service for beskadigelse
 Om du sender en beskadiget karte du får dette servicekort direkte til nummeret som angives ned. Kun på det måde kan det sende møbelpartier til vores beskadigelse på fax. Om du vil reklamere dit møbel er en anden anledning måske du forstaae dit møbelhus direkte.

ES Nuestro servicio directo para reparaciones
 Si le falta algún accesorio, puede enviar esta tarjeta de servicio directamente a la siguiente dirección. No obstante, por esta vía solo podemos enviar accesorios. Si tiene alguna otra objeción sobre su mueble, consulte directamente con su mueblera.

TR Donatılar için doğrudan servisi
 Bir donatıya ihtiyaç duvarsanız servisi doğrudan aşağıdaki bulan adres üzerinden mail vasıtasıyla gönderebilirsiniz. Ancak, bu yolla donatılar gönderilemez. Mobilyanızda başka bir sorun varsa, lütfen doğrudan mobilya satışınıza danışın.

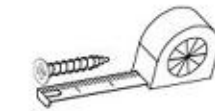

A1 ø7x50 x...	W1 ø16x160 x...	G56 4x16 x...
S2 x...	W2 x...	N15 M4x25 x...
A6 ø7x40 x...	H24 H35-400mm x...	G20 5x13 x...
K1 ø15x12 x...	I7 ø18 x...	I1 x...
K15 ø8x35 x...	B1 x...	G34 3,5x16 x...
M11 x...	P27 x...	E93 x...
P4 x...	F12 x...	

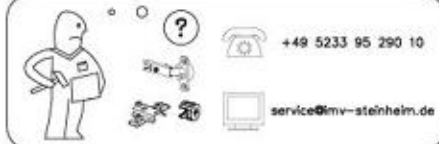

Name • Nom • Nome • Naam • Nazwa • Иméно • Νόζον • Névn • Denumire • Isim • Извание	Nr • No • N° • Номер • Č • Sz	Typ • Type • Tip • Típus • Тíро • Tun
LANDHAUS	--	32

D Unser Direktservice für Beschädigte
Sollte Ihnen ein Beschädigter Schaden, können Sie diese Servicekarte direkt an die unternahmende Hersteller senden. Wir können allerdings nur Beschädigte auf diesem Weg verschicken. Sollen Sie eine andere Beanstandung an Ihrem Möbelstück haben, so wenden Sie sich bitte direkt an Ihr Möbelhaus.

GB Our direct order service for fitting
If a fitting should be missing to you, you know this service card directly following number boxes, we can in this way send away however only fitting. If you should have another objection to your piece of furniture, then they turn please to your furniture house.

CZ Nežte přímé služby pro lování
Chybi-li vám nějaký díl z lovení, můžete tuto službu kartu odložit přímo na náš úvazek. Tuto osobu však můžeme poslat jen díky lovení. Pokud byste měli další problém, obraťte se přímo na svého prodejce nábytku.

F Ne pas étudier le notice de montage
Ne pas les pièces composées votre meuble. Rejoindre et contrôler le fournisseur. Montage - vous de l'aide nécessaire. Aménager - vous une zone de montage. Procéder au montage. Ne jamais forcer les assemblages. Remettre les vis dans quelques temps d'usage. Garder votre notice de montage, si une pièce venait à manquer, elle serait le plus sûr moyen de communiquer avec votre magasin.

I Il nostro servizio diretto per l'ordine delle forniture
Nel caso di mancanza del pezzo, potete spedire fax questa carta di servizio direttamente al seguente numero. Per altri problemi al vostro mobile, potete rivolgervi al vostro mobilificio.

BG Директно обслужаване на повреден обект
Ако обектът ви е повреден, можете да изпратите тази директна карта за услуги директно на следния номер. За всички други проблеми относно обекта ви, моля да се свържете с вашия магазин.

NL Directe dienstverlening voor schade
Wanneer er een onderdeel mist kunt u deze servicekaart direct aan onze afdeling Beschadigd sturen. Wij kunnen alleen langs deze weg onderdeel versturen. Mocht u een ander probleem aan uw meubel hebben verstaan wij u contact op te nemen met uw meubelwiel.

PL Należy bezpośrednio serwisować uszkodzony obiekt
Jeżeli brakuje części koniecznych do montażu, prosimy o przesłanie nam tej karty serwisowej na niżej podany numer faxu. Możemy w ten sposób przysłać potrzebne tylko brakujące części. W przypadku innych szkód dotyczących mebla, prosimy o zgłoszenie ich do naszego meblowego w którym został dokonany zakup.

HR Servis za štete
U slučaju da nedostaje neki od dijelova mebla vas da ne dalje navestiti fax broj poslate ovaj servisni obrazac. Na ovaj način mogu se dostaviti samo dijelovi. U slučaju da imate dodatne prigovore vezane uz instalaciju mebla vas da se konsultiramo telefonom ili putem naše kartice za štete na 1403.

HU Direktrendelésű károsított objektus
Ha sérült egy részecskét, ezt a károsított objektusokhoz az eladó vállalkozásunknak, közvetlen módon meg kell küldeni. Minden más problémát a károsított objektusokhoz, forduljon közvetlenül a boltunkhoz.

SK Náš priamy servis pre škodu
Ak by Vám chýbala niektorá časť mebla, môžete poslať túto službu kartu priamo na náš úvazok. Tuto osobu však môžeme poslať c iba vďaka škodám. Ak by ste mali iný problém súvisiaci s inštaláciou nábytku, obráťte sa priamo na vášho predajcu nábytku.

SLO Nežte direktno službu štete
Če vam manjka kakšno delce, lahko to servisu kartico pošljete po faxu direktno na našo službo. Tuto osebo lahko pošljemo samo obtožbo. Če imate kakšne druge pritožbe, se obrnite neposredno na vašo trgovino pohištva.

RO Serviciu directă pentru furnitură
În cazul în care vă lipsește o piesă de furnitură puteți să trimiteți direct această card de servicii pe fax la numărul de mai jos. Noi nu putem trimite piese de furnitură decât pe această cale. Dacă aveți o altă reclamație referitoare la piesa de mobilier, atunci vă rugăm să vă adresați direct la magazinul dvs. de mobilă.

RUS Наш прямой сервис для поврежденных объектов
Если имеется повреждение, то мы можем отправить вам только необходимые детали. Все остальные претензии по поводу мебели мы можем отправить только напрямую. Для получения информации или консультации обращайтесь непосредственно в магазин, осуществляющий продажу.

S Vår direkte service for beskadigelse
Om du sender en beskadigelse kan du få de nødvendige dele direkte til os. Vi kan kun sende dele på denne måde. Hvis du har andre spørgsmål om møbler, skal du direkte til din møbelbutik.

ES Nuestro servicio directo para averías
Si te falta algún accesorio, puede enviar esta tarjeta de servicio directamente a la siguiente dirección. No obstante, por esta vía solo podemos enviar accesorios. Si tienes alguna otra objeción sobre tu mueble, consulta directamente con tu mueblero.

TR Donatılar için doğrudan servisi
Bir donatıya ihtiyacınız varsa veya mobilyanızda bir parçanın kırıldığını düşünüyorsanız, bu parçaları doğrudan bizimle iletişime geçerek talep edebilirsiniz. Diğer tüm mobilya sorunlarınızı doğrudan mağazanızla iletişime geçiniz.

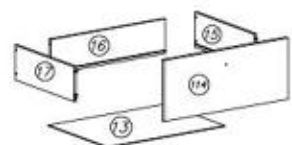
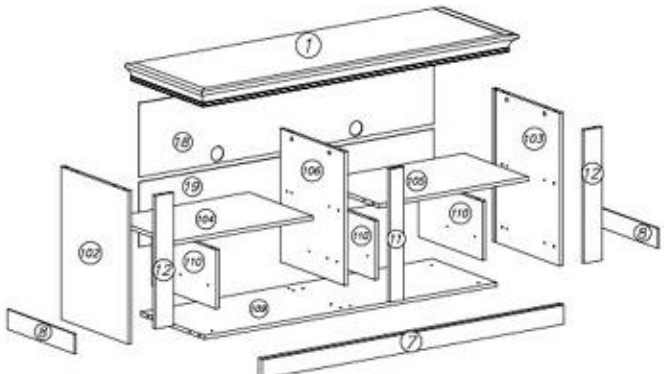

Nr	L[mm]	H[mm]	T[mm]	Stange	Q[mm]
1	1514	510	70		2/2
102	618	456	16		2/2
103	618	456	16		2/2
104	664	436	16		2/2
105	711	436	16		2/2
106	539	436	16		2/2
7	1436	80	22		1/2
8	456	80	6		1/2
109	1391	436	16		1/2
110	238	436	16		2/2
11	538	65	18		2/2
12	538	85	18		1/2
13	557	401	3		2/2
114	569	247	16		1/2
15	400	140	12		1/2
16	347	140	12		1/2
17	400	140	12		1/2
18	1403	299	3		1/2
19	1403	262	3		1/2

