

TV-Schrank-N621P172788/N621P72796

- Assembly instructions. Please keep them for future reference.
- Montageanweisungen. Bitte bewahren Sie sie für zukünftige Referenzen auf.
- Instructions de montage. Veuillez les garder pour vérification.

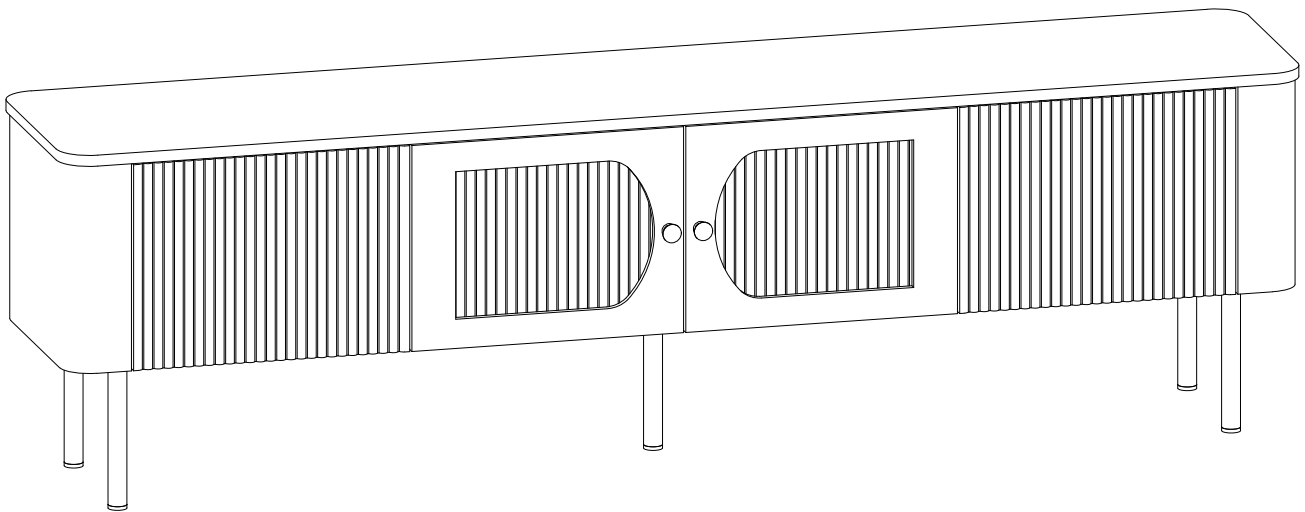

- This product is divided into two packages.
- Dieses Produkt ist in zwei Packungen unterteilt.
- Ce produit est livré en deux packs.
- Important - Please read these instructions fully before starting assembly.
- Wichtig: Bitte lesen Sie diese Anleitung vollständig durch, bevor Sie mit der Montage beginnen.
- Important - Lisez ces instructions dans leur intégralité avant de commencer l'assemblage.

-Components - fittings

Please check you have all the panels listed below.

Note: The quantitie below are the correct amount to complete the assembly. In some cases more fittings may be supplied than are required.

-Komponenten Verschraubungen

Bitte überprüfen Sie, ob Sie alle unten aufgeführten Panels haben.









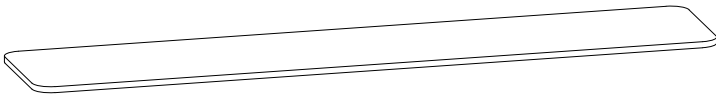

Hinweis: Die folgende Menge ist die richtige Menge, um die Montage abzuschließen. In einigen Fällen können mehr Armaturen geliefert werden, als erforderlich.

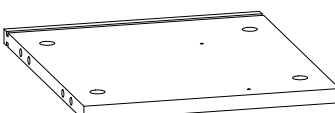
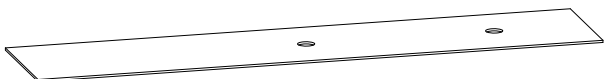
-Composants - accessoires

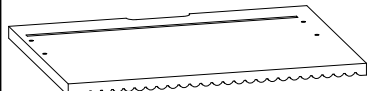
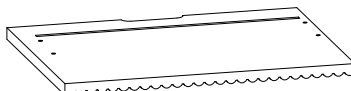

Veillez vérifier que vous possédez tous les panneaux énumérés ci - dessous.

Remarque: les quantités ci - dessous sont les quantités correspondantes nécessaires pour terminer l'assemblage. Dans certains cas, plus d'accessoires que nécessaire peuvent être fournis.

N621P172788 - Box:1/2

			
① x 1pc		② x 1pc	
			
⑤ x 1pc	⑥ x 1pc	⑦ x 1pc	
			
⑧ x 1pc	⑨ x 1pc	⑩ x 1pc	⑪ x 2pcs
			
⑫ x 2pcs	⑬ x 2pcs	⑭ x 2pcs	⑮ x 2pcs

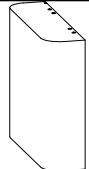
N621P72796 - Box:2/2

	
③ x 1pc	④ x 1pc

·Components - fittings

Please check you have all the panels listed below.

Note: The quantitie below are the correct amount to complete the assembly. In some cases more fittings may be supplied than are required.

·Komponenten Verschraubungen

Bitte überprüfen Sie, ob Sie alle unten aufgeführten Panels haben.









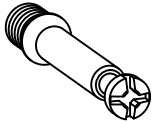

Hinweis: Die folgende Menge ist die richtige Menge, um die Montage abzuschließen. In einigen Fällen können mehr Armaturen geliefert werden, als erforderlich.

·Composants - accessoires

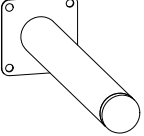
Veuillez vérifier que vous possédez tous les panneaux énumérés ci - dessous.

Remarque: les quantités ci - dessous sont les quantités correspondantes nécessaires pour terminer l'assemblage. Dans certains cas, plus d'accessoires que nécessaire peuvent être fournis.

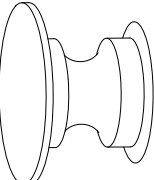
Hardware-Liste :N621P72796

 M6x35mm	 Φ15x9mm	 Φ8x30mm	 M3x12mm
A x 24pcs	B x 24pcs	C x 16pcs	D x 16pcs
		 M4x12mm	 M4x25mm
E x 4pcs	F x 5pcs	G x 44pcs	H x 8pcs
		 M4x22mm	
I x 4pcs	J x 2pcs	K x 2pc	L x 1pc

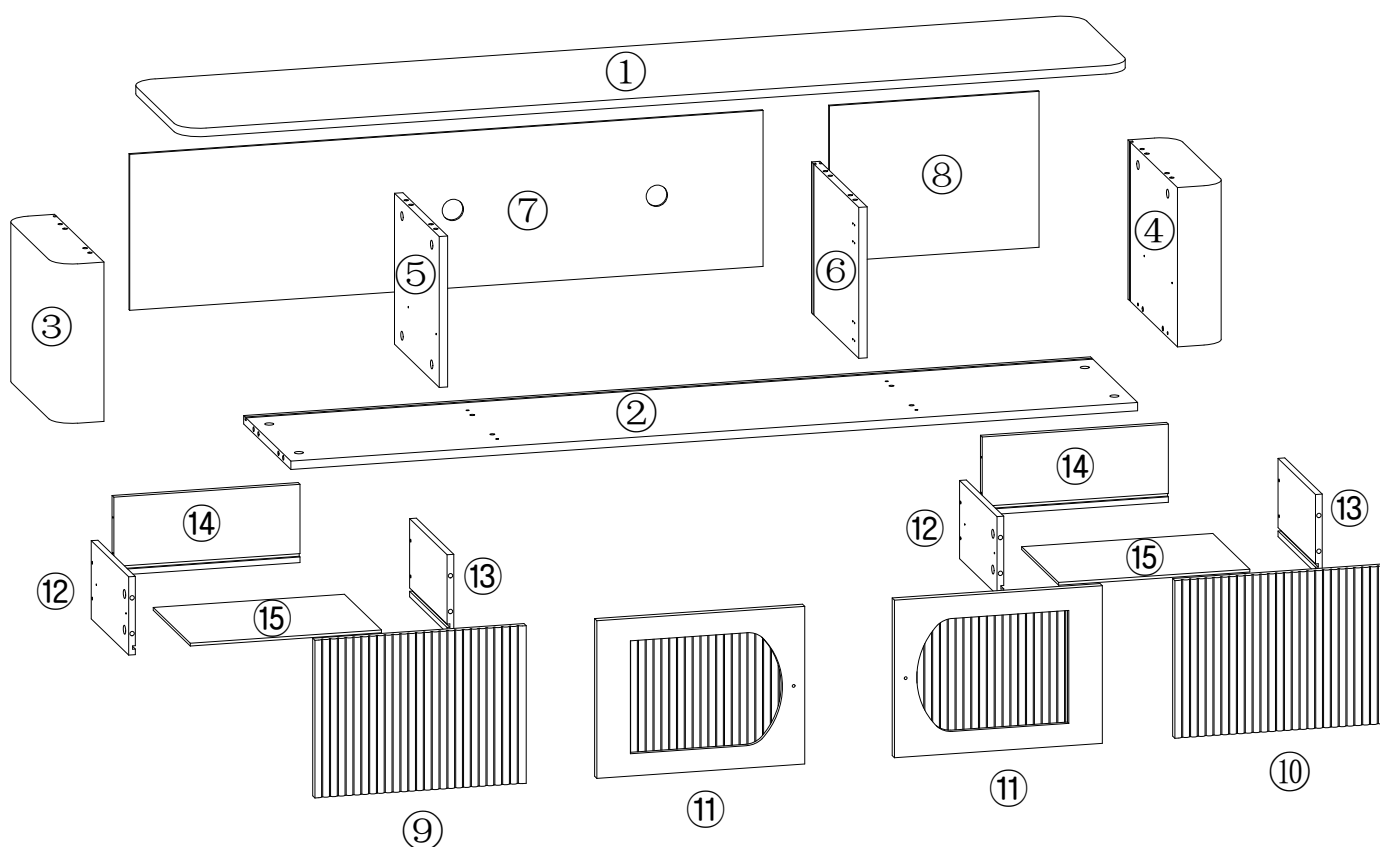

Importeur	Decobus Handel GmbH		
Adresse	Innungsstraße 9, 21244 Buchholz, Deutschland		
URL	https://www.decobusgroup.de		
Hersteller	SILVER UNION INVESTMENTS LIMITED		
Adresse	PORTCULLIS CHAMBERS, P.O. BOX 1225, APIA, SAMOA		
Email/URL	372726447@QQ.COM		
<table border="1" style="display: inline-table; vertical-align: middle;"> <tr> <td style="text-align: center;">EC</td> <td style="text-align: center;">REP</td> </tr> </table>	EC	REP	Decobus Handel GmbH
	EC	REP	
	Innungsstraße 9, 21244 Buchholz, Deutschland		
https://www.decobusgroup.de			

Assembly Instructions/Montageanleitung/Instructions de montage

STEP 1/SCHRITT 1/Étapes 1

- Slides Must Be Separated Before Assembly.
- After Separated, Set Aside Until Needed for Assembly.
- Folien müssen vor der Montage getrennt werden.
- Nach der Trennung beiseite stellen, bis zur Montage benötigt wird.
- Les diapositives doivent être séparées avant l'assemblage.
- Une fois séparés, mettez de côté jusqu'à ce que vous ayez besoin de les assembler.

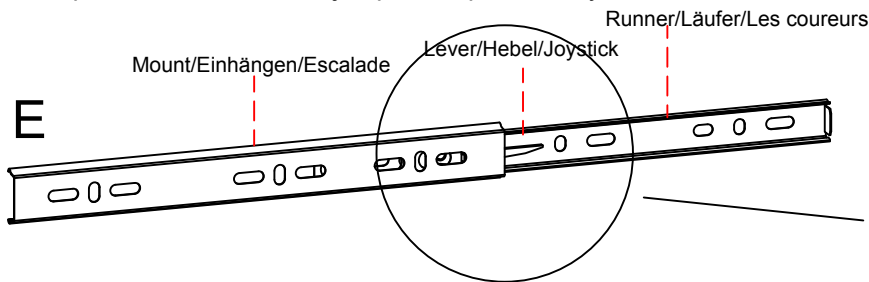

STEP 1: Extend Slide
SCHRITT 1: Slide erweitern
Étape 1: étirer la diapositive

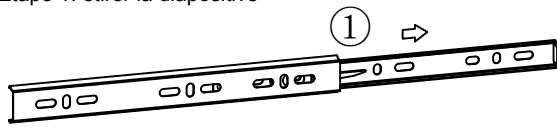

STEP 3: Remove Runner
SCHRITT 3: Läufer entfernen
Étape 3: retirer la roue tournante

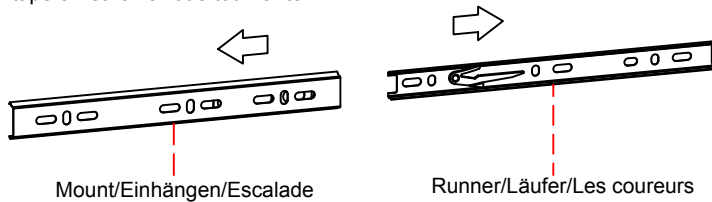

STEP 2: Push Lever UP
Schritt 2: Hebel nach oben drücken
Étape 2: Poussez le joystick vers le Haut

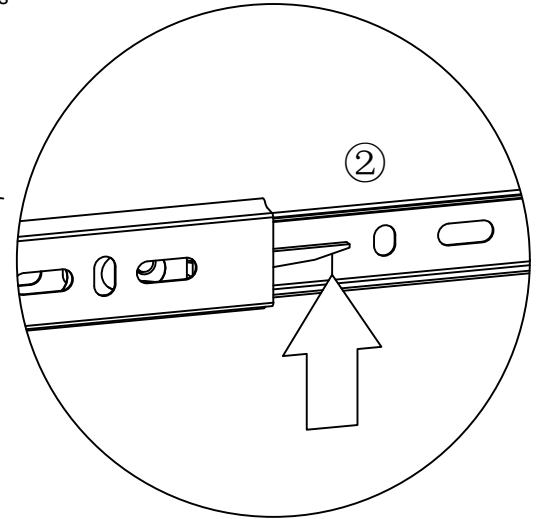

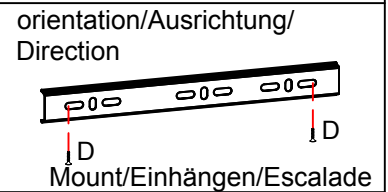
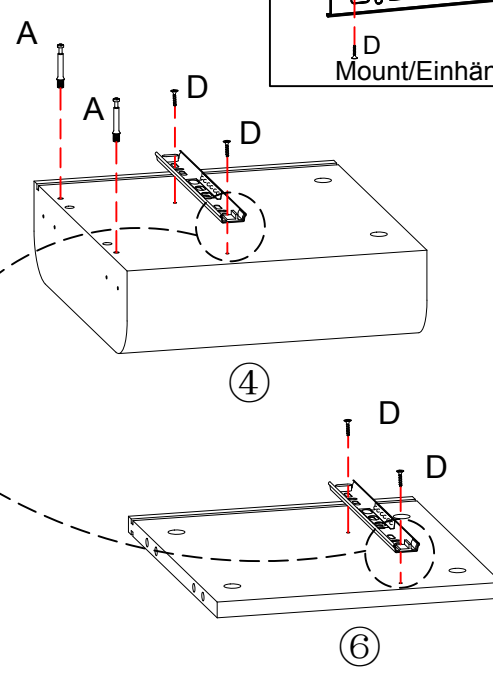
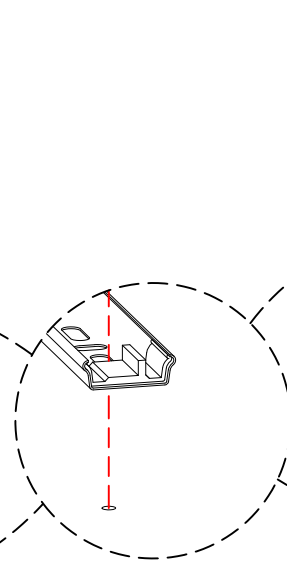
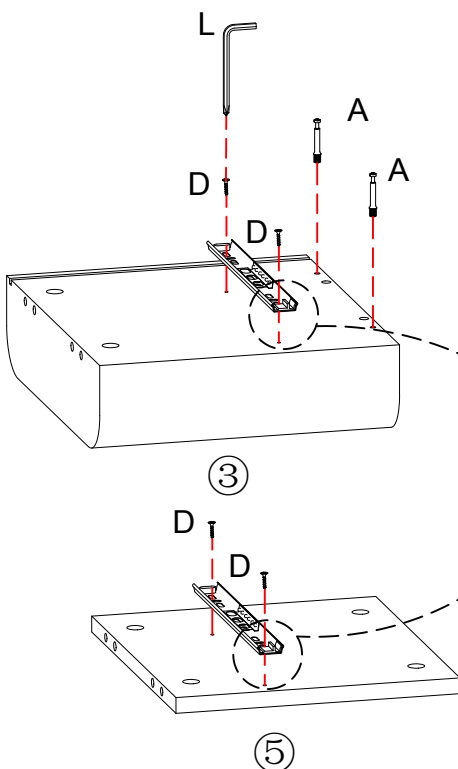

STEP 2/SCHRITT 2/Étapes 2



A x4pcs	D x8pcs	E x 4pcs	L x1pc

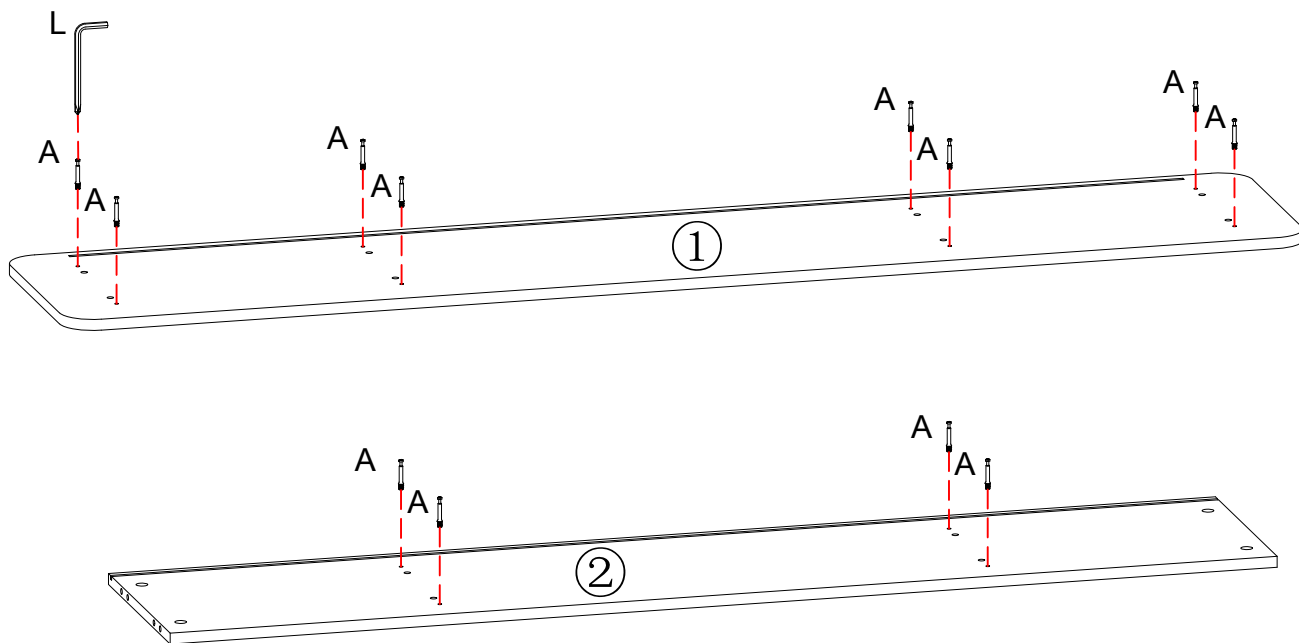

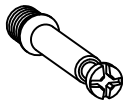
STEP 3/SCHRITT 3/Étapes 3

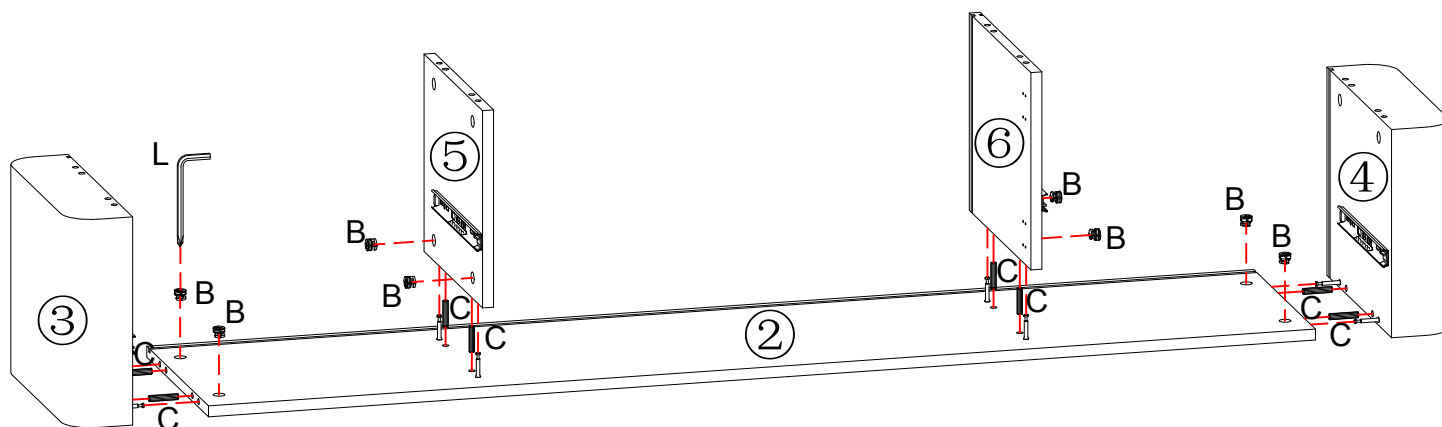

	
A x12pcs	L x1pc

STEP 4/SCHRITT 4/Étapes 4



		
B x8pcs	C x 8pcs	L x1pc

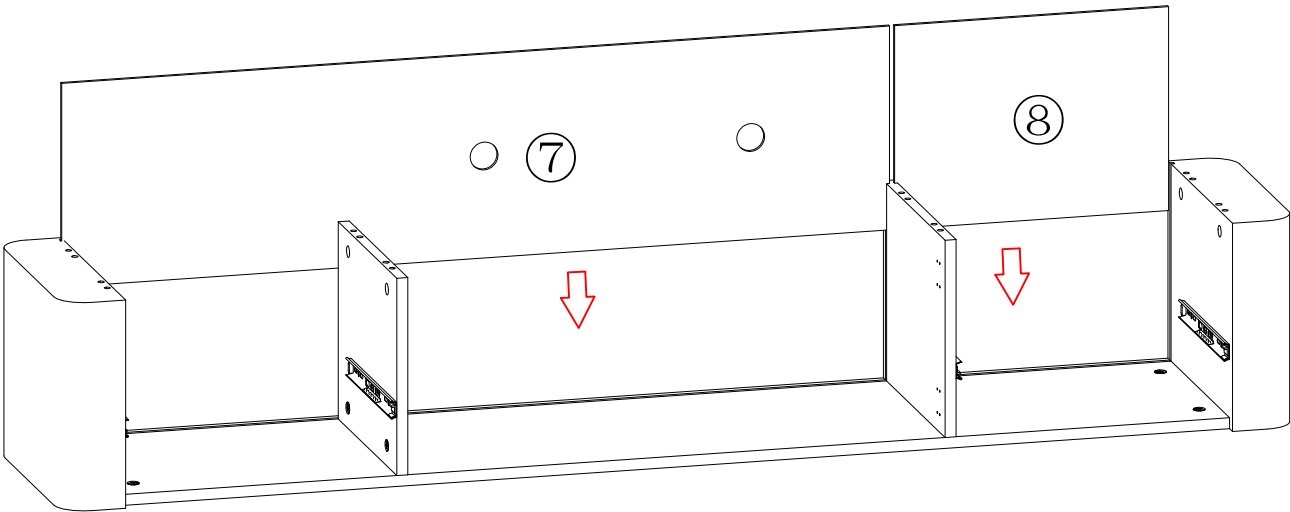

Assembly Instructions/Montageanleitung/Instructions de montage

STEP 5/SCHRITT 5/Étapes 5

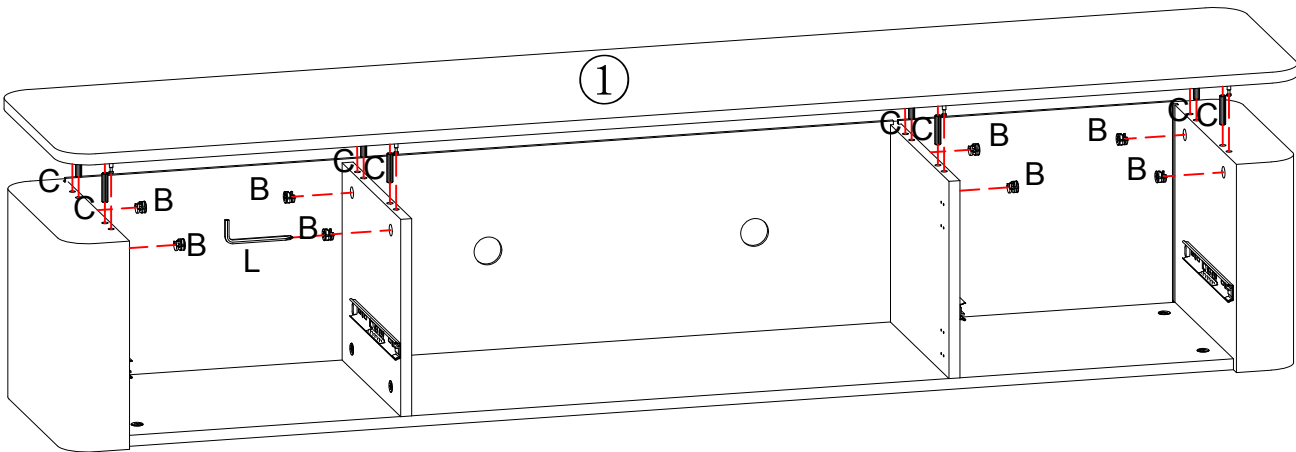

STEP 6/SCHRITT 6/Étapes 6



		
B x8pcs	C x 8pcs	L x1pc

STEP 7/SCHRITT 7/Étapes 7

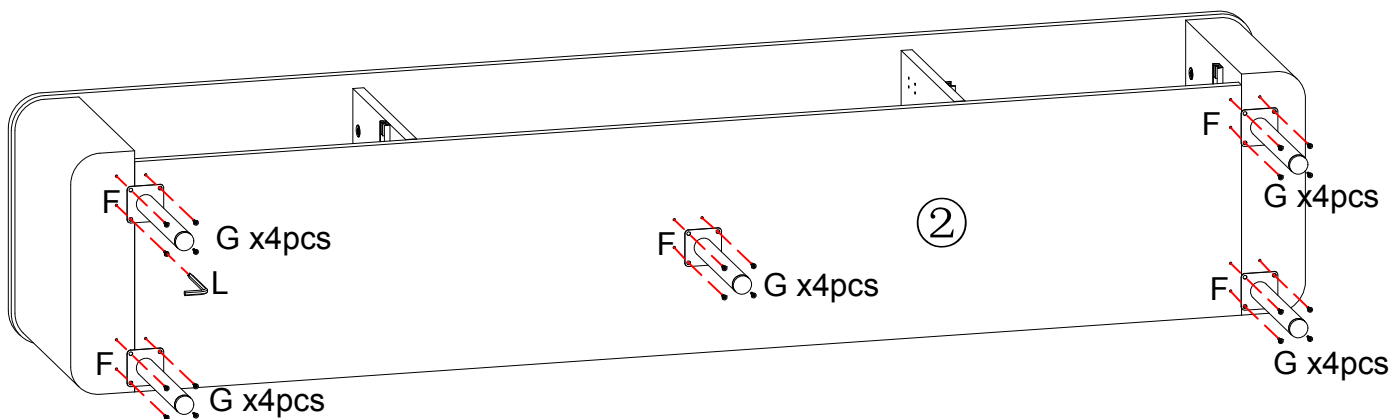

		
F x 5pcs	G x 20pcs	L x 1pc

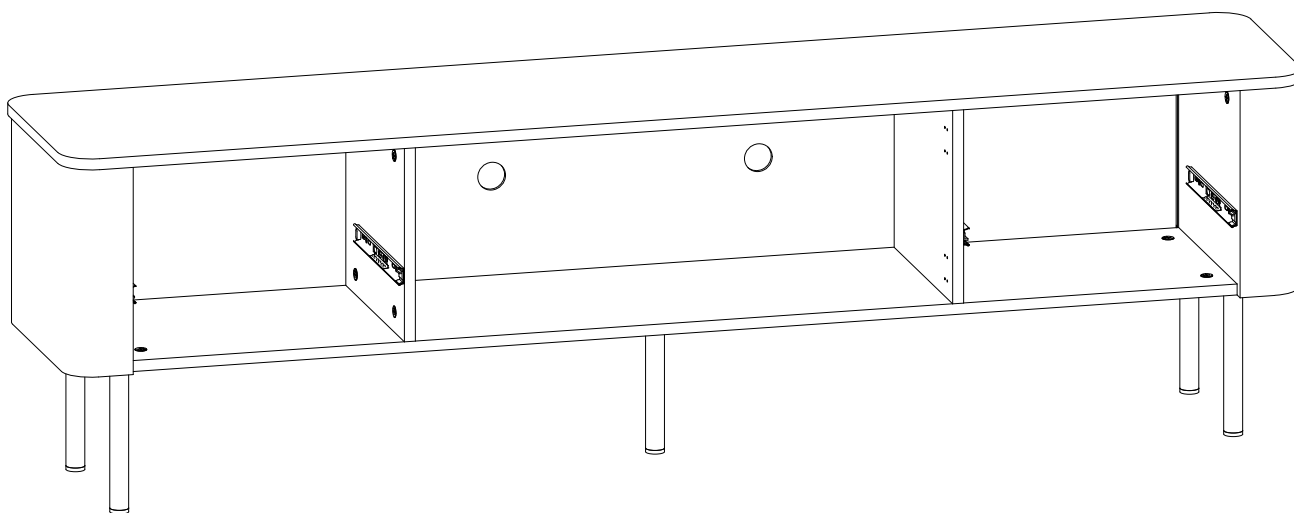

STEP 8/SCHRITT 8/Étapes 8



Assembly Instructions/Montageanleitung/Instructions de montage

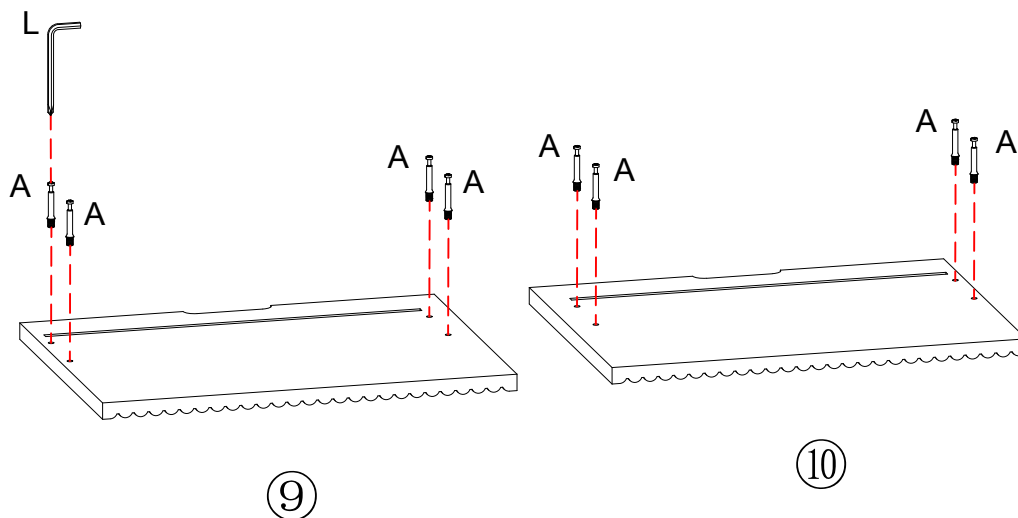

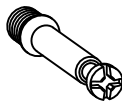
STEP 9/SCHRITT 9/Étapes 9

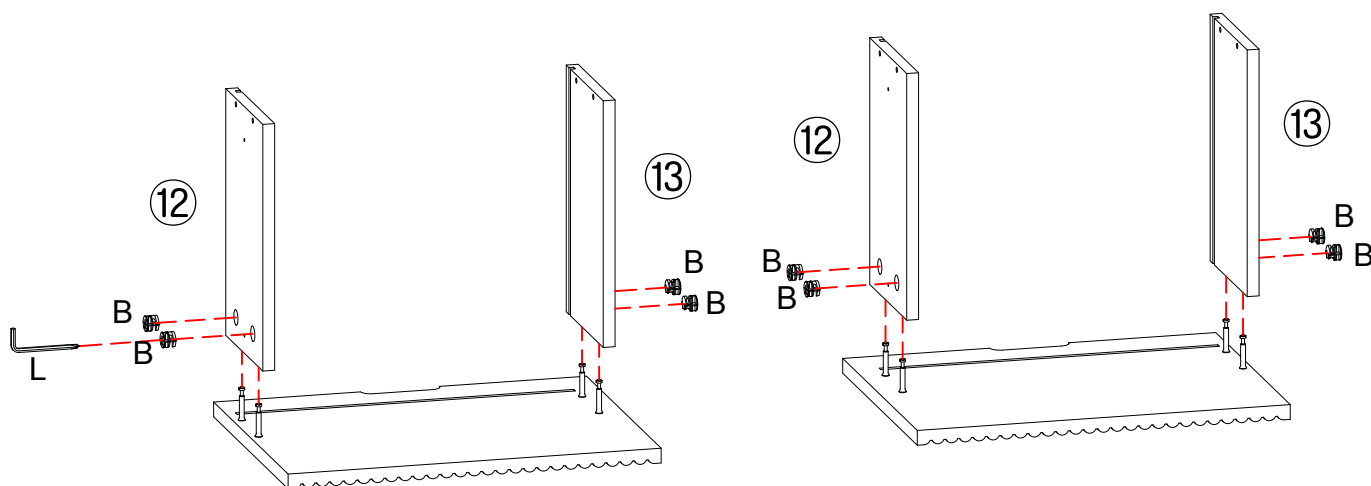

	
A x 8pcs	L x1pc

STEP 10/SCHRITT 10/Étapes 10





	
B x 8pcs	L x1pc

Assembly Instructions/Montageanleitung/Instructions de montage

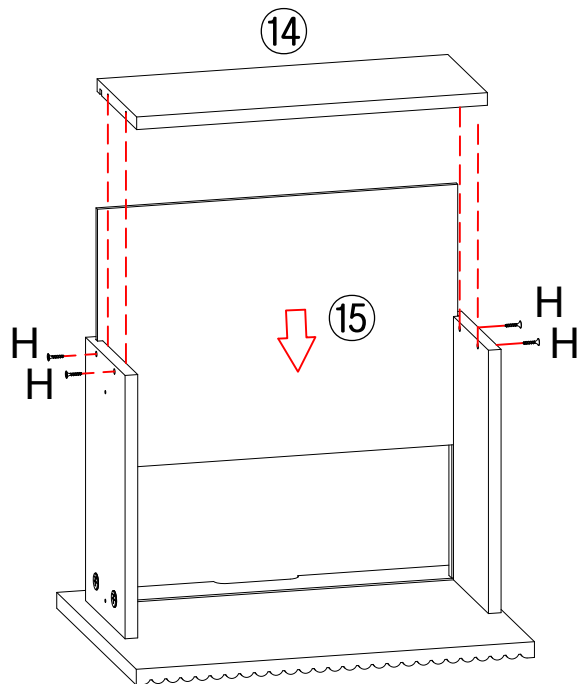
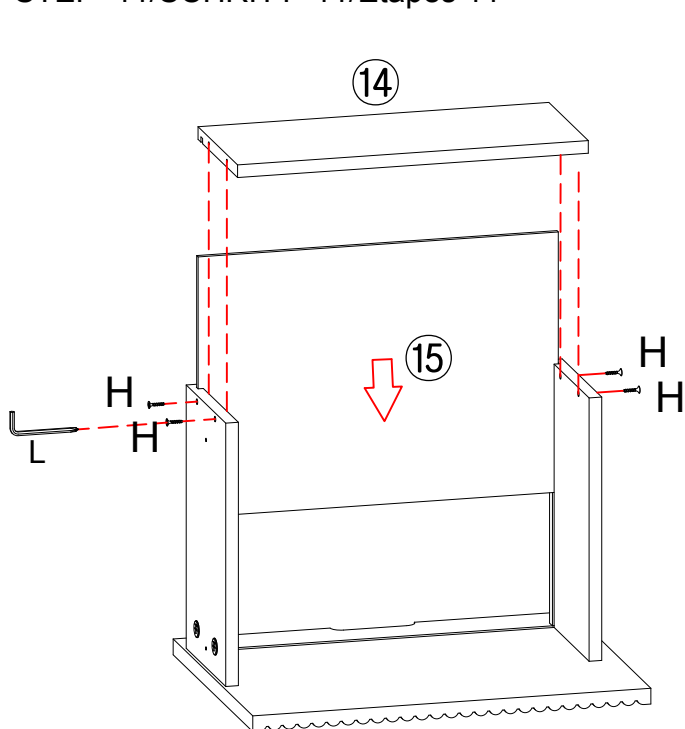
STEP 11/SCHRITT 11/Étapes 11



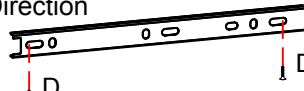

	
H x 8pcs	L x1pc

STEP 12/SCHRITT 12/Étapes 12

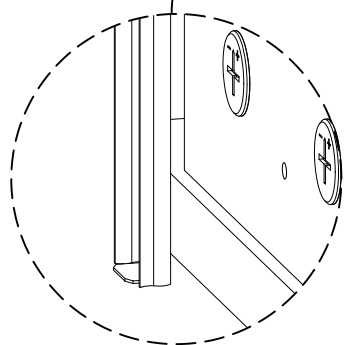
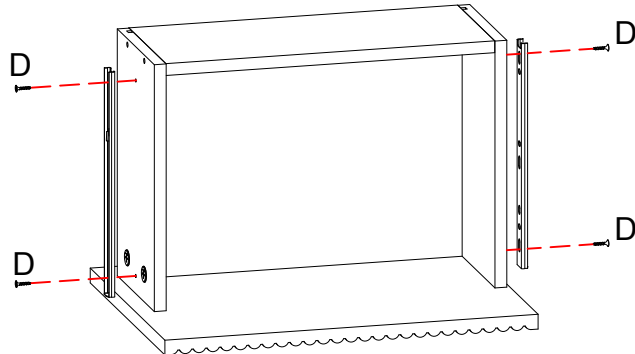
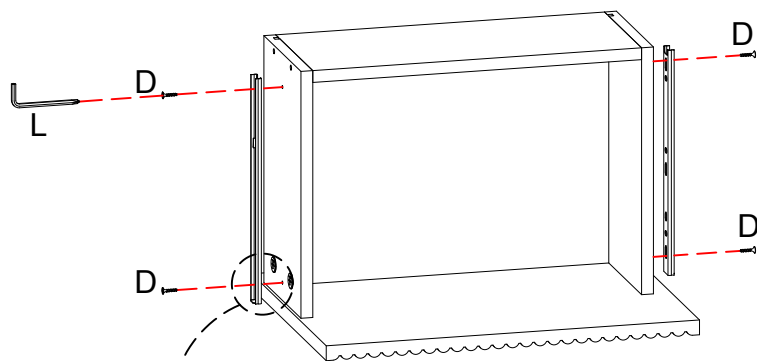
orientation/Ausrichtung/ Direction

Runner/Läufer/Les coureurs



		
D x 8pcs	Runner/Läufer/ Les coureurs E x4pcs	L x1pc



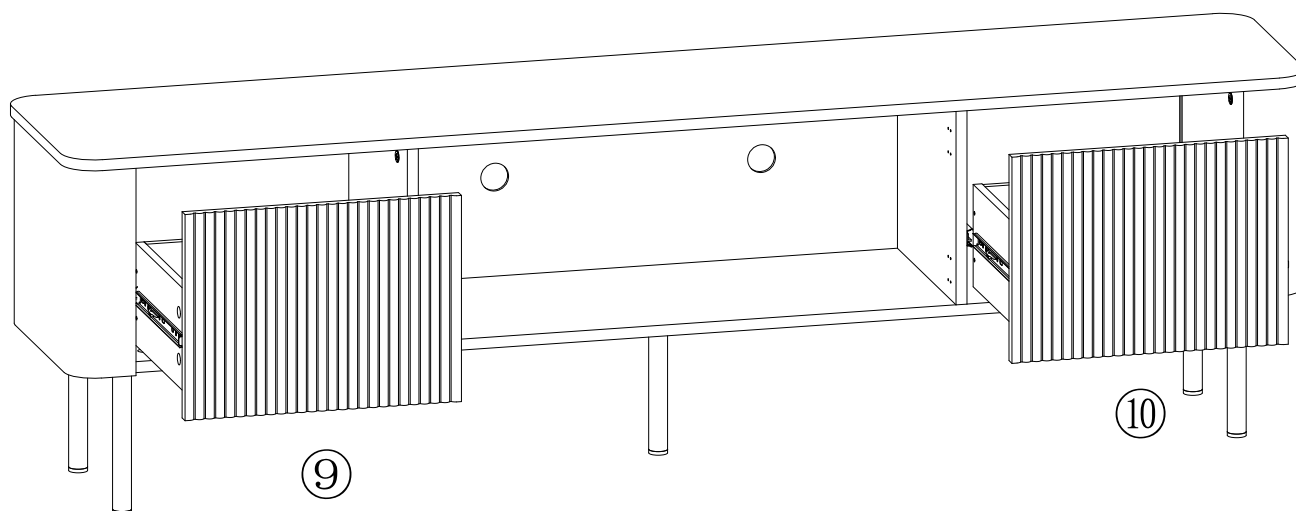

Assembly Instructions/Montageanleitung/Instructions de montage

STEP 13/SCHRITT 13/Étapes 13

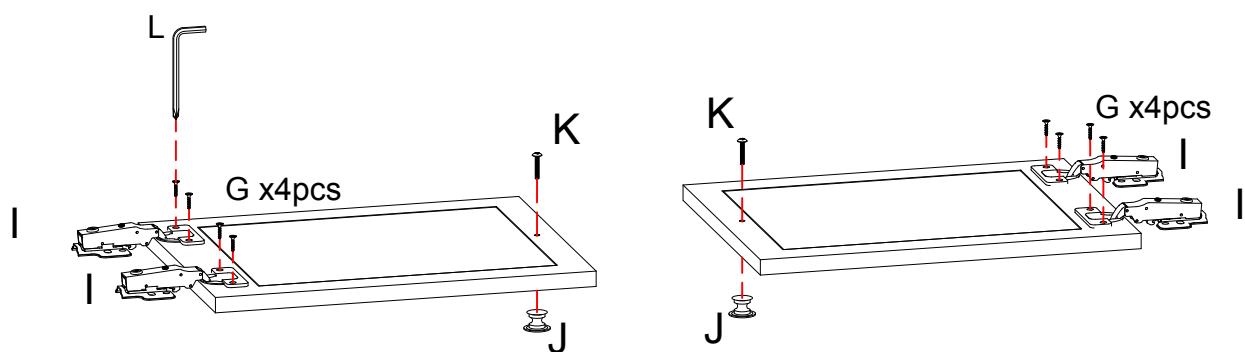

STEP 14/SCHRITT 14/Étapes 14



				
G x 8pcs	I x 4pcs	J x 2pcs	K x 2pcs	L x 1pc

Assembly Instructions/Montageanleitung/Instructions de montage

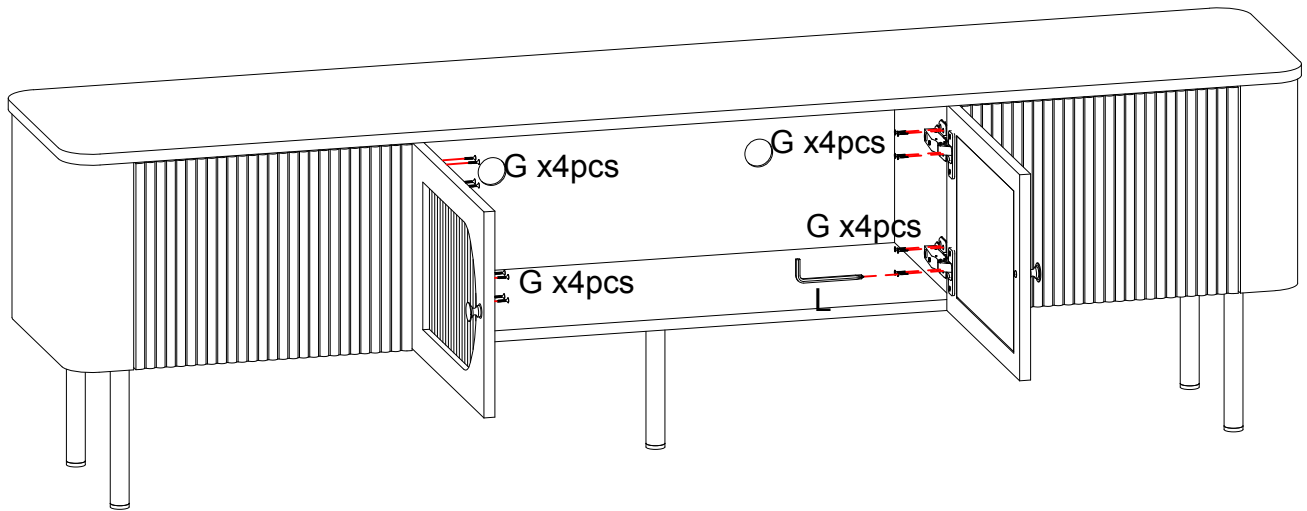

STEP 15/SCHRITT 15/Étapes 15

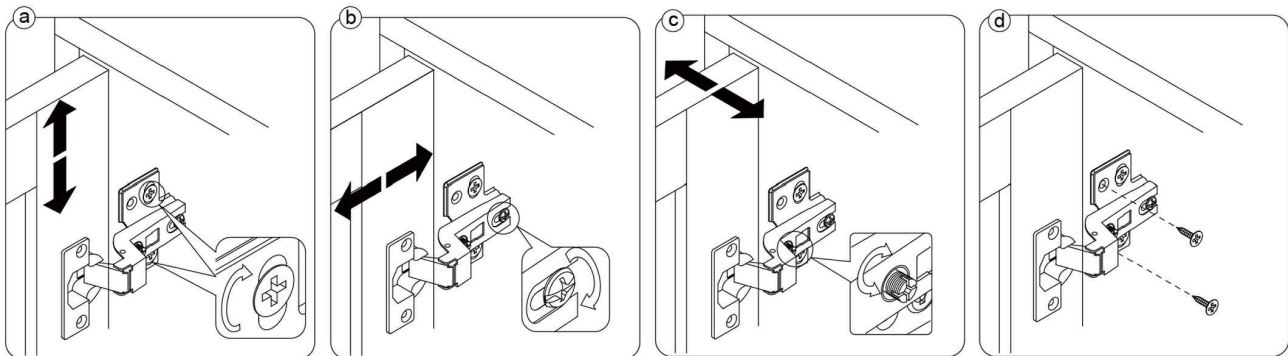

- When the hinges are installed, you can refer to the pictures to adjust crevice of the doors till it's perfect:
- Wenn die Scharniere installiert sind, können Sie sich die Bilder ansehen, um den Spalt der Türen anzupassen, bis es perfekt ist:
- Lorsque la charnière est installée, vous pouvez vous référer à l'image pour ajuster la fente de la porte jusqu'à ce qu'elle soit parfaite:



1. To adjust the doors up and down, please refer to step (a)
 2. To adjust the distance between the doors and side panels, please refer to step (b)
 3. To adjust the gap between two doors, please refer to step (c)
 4. After the adjustment finished, please tighten the screws, refer to step (d)
1. Um die Türen nach oben und unten einzustellen, siehe Schritt (a)
 2. Um den Abstand zwischen den Türen und den Seitenwänden einzustellen, lesen Sie bitte Schritt (b)
 3. Um den Abstand zwischen zwei Türen einzustellen, siehe Schritt (c)
 4. Nachdem die Einstellung beendet ist, ziehen Sie bitte die Schrauben fest, siehe Schritt (d)
1. Pour régler les portes de haut en bas, reportez - vous à l'étape (A)
 2. Pour régler la distance entre la porte et le panneau latéral, reportez - vous à l'étape (b)
 3. Pour régler l'écart entre les deux portes, reportez - vous à l'étape (c)
 4. Une fois le réglage terminé, serrez les vis, voir étape (d)

	
G x 16pcs	L x 1pc