



CBA MEUBLES

178 à 184 rue de la Prévôté

BP 49

59840 PERENCHIES

FRANCE

SAV
SPAREPARTS
KUNDERDIENST
POS VENTAS
SERVICE NA VERKOOP
SERVIZIO POST-VENDITA
SERVICO DEPOIS DE VENDA
ÉRTÉKESÍTÉS UTÁN
NAKON PRODAJE
بعد البيع

287 788-00

**LONGANE
SLIDE BED**

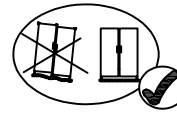
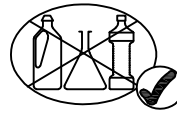

Option 1
(90x200 cm)

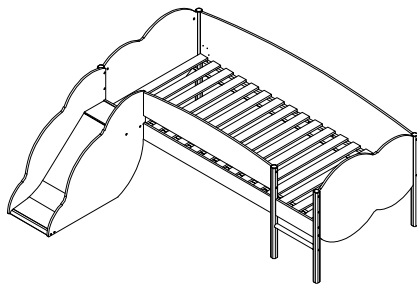

Option 2
(90x200 cm)

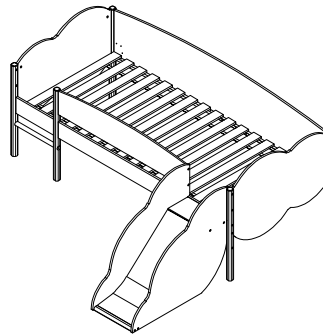

Option 3
(90x190 cm)

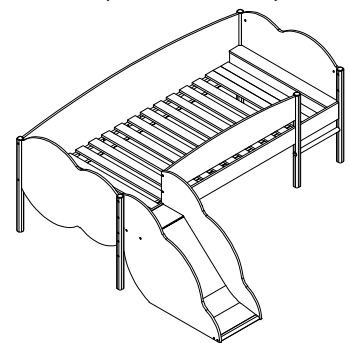

Option 4
(90x190 cm)

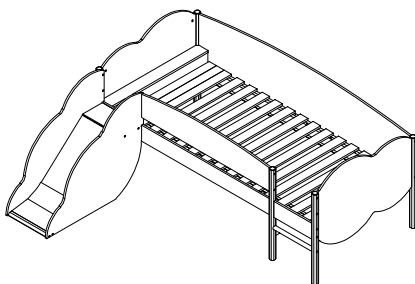

Option 5
(90x190 cm)

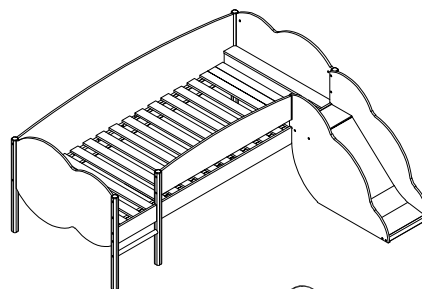

Option 6
(90x190 cm)

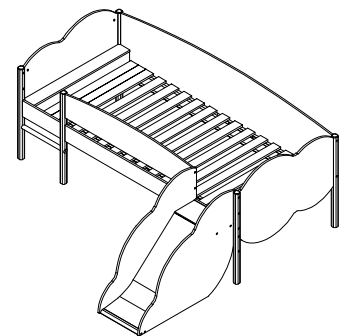

4H 00MN



(FR) SECURITE

RESPECTER LES INSTRUCTIONS DE MONTAGE DECRITES DANS LA NOTICE.
CE LIT N'EST PAS UN JOUET. NE LAISSEZ PAS UN ENFANT ESCALADER LA STRUCTURE AU DESSUS DU COUCHAGE.

(EN) CAUTION

FOLLOW CAREFULLY THE ASSEMBLY INSTRUCTIONS DESCRIBED IN THE DIRECTION
BED NOT TO BE USED AS A GAME. DO NOT ALLOW THE CHILDREN TO CLIMB ONTO THE ROOF OF THE BED.

(DE) SICHERHEITSVORSCHRIFTEN

BEACHTEN SIE BITTE UNBEDING DIE ANGEGBENEN AUFBAUVORSCHRIFTEN
NICHT ALS SPIELGERÄT ZU VERWENDEN. LASSEN SIE DIE KINDER NICHT AUF DAS DACH DES BETTES STEIGEN.

(ES) SEGURIDAD

RESPECTAR LAS INSTRUCCIONES DE MONTAJE DESCRIBIDAS EN EL FOLLETO
ESTA CAMA NO ES UN JUEGO. NO DEJAD UN NIÑO SUBIR POR ENCIMA DE LA ESTRUCTURA DE LA CAMA.

(NL) VEILIGHEID

DE IN DE GEBRUIKSAANWIJZING BESCHREVEN INSTRUCTIE RESPECTEREN
HET BED IS GEEN SPEELGOED. KINDEREN MOGEN NIET OP HET DAK VAN HET BED KLIMMEN.

(IT) SICUREZZA

RISPETTARE LE ISTRUZIONI DI MONTAGGIO DESCRITTE NEEL'AVVERTENZA
QUESTO LETTO NON È UN GIOCATTOLO. NON LASCIATE UN BAMBINO SCALARE LA STRUTTURA SOPRA IL LETTO.

(PT) SEGURANCA

RESPEITAR AS INSTRU ÇOS DE MONTAGEH DESCRVEDAS NA INSTRU ÇOES DE USO
ESTA CAMA NÃO É UM JOGO. NÃO DEIXEM UMA CRIANÇA ESCALAR A ESTRUTURA EM CIMA DA DORMIDA.

(HU) BIZTONSÁG

KÖVESSE A KÉZIKÖNYVBEN LEÍRT ÖSSZESZERELÉSI UTASÍTÁSOKAT.
EZ ÁGY NEM JÁTÉK. NE ENGEDJÉ GYERMEKET, HOGY AZ ÁGYFELÜLET FÖLTI SZERKEZETE MÁSSZA.

(CR) SIGURNOST

SLJEDITE UPUTE ZA SASTAVLJANJE OPISANE U PRIRUČNIKU.
OVAJ KREVET NIJE IGRACKA. NE DOPUSTITE DJETETU DA SE PENJE NA KONSTRUKCIJU IZNAD POSTELJINE.

(AR) الحذر

اتبع بعناية تعليمات التجميع الموضحة في الاتجاه
لا ينبغي استخدام السرير كلعبة. لا تسمح للأطفال بالتسلق على سطح السرير.



MADE IN VIET NAM

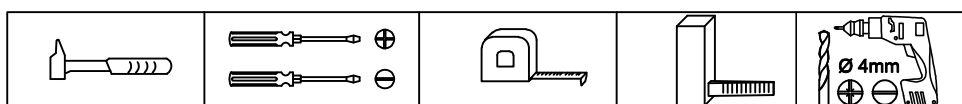

Français :

- Notice à conserver.
- En cours du montage, prenez garde aux risques de pincement et de cisaillement.
- Ne pas mettre le lit à proximité d'une source de chaleur.
- Ne pas s'asseoir à plusieurs sur le lit.
- Ne pas sauter sur le lit.
- Stocker le lit dans un endroit sec.
- Ne convient pas à un enfant de moins de 4 ans.
- Les meubles contenant des panneaux à base de bois (panneaux de particules, panneaux de fibres, contreplaqué...) peuvent émettre des substances polluantes dans l'air intérieur . Il est ainsi recommandé , après l'installation du meuble dans son logement, d'aérer fréquemment la pièce concernée pendant au moins quatre semaines afin de réduire son exposition aux polluants émis par le meuble.*

English :

- Retain the instructions for future reference.
- During the assembly, beware the risks of pinching and shearing.
- Keep the product away from heat sources.
- Do not sit on the bed several.
- Do not jump on the bed.
- Store the bed in a dry place.
- Not suitable for children under 4 years old.

Deutsch :

- Notiz zum Aufbewahren.
- Während der Montage bitte darauf achten sich nicht zu -schneiden oder einzuklemmen das Bett nicht zu Nahe an einen Heizkoerper stellen.
- Sich nicht gleichzeitig zu mehreren auf das Bett setzen.
- Nicht springen auf dem Bett.
- Das Bett an einem trockenen Platz aufbewahren.
- Nicht geeignet für Kinder unter 4 Jahren.

Español :

- Aviso .
- Durante el montaje, tenga cuidado con los riesgos de aplastamiento y cizallamiento.
- Fuente de fuego.
- No sentarse varias personas en la cama.
- No salte en la cama.
- Poner la cama en un lugar seco.
- No apto para niños menores de 4 años.

Nederlands :

- Bewaar deze instructie goed.
- Tijdens de montage, vermijd persen en drukken.
- Het bed niet naast een verwarmingsbron plaatsen.
- Niet met meerdere personen op het bed zitten.
- Niet op het bed springen.
- Het bed in een droge plaats bewaren.
- Niet geschikt voor kinderen jonger dan 4 jaar.

Italy:

- Conservare le istruzioni per riferimenti futuri.
- Durante l'assemblea, attenzione i rischi di schiacciamento e di taglio.
- Tenere il prodotto lontano da fonti di calore .
- Non sedersi sul letto parecchi.
- Non saltare sul letto.
- Conservare il letto in un luogo asciutto.
- Non adatto a bambini sotto i 4 anni.

Portugal :

- Guarde as instruções para referência futura.
- Durante a montagem, tenha cuidado com os riscos de beliscadura e de corte.
- Mantenha o produto longe de fontes de calor.
- Não se sentar na cama vários.
- Não pule na cama.
- Guarde a cama em um local seco.
- Não recomendado para crianças menores de 4 anos de idade.

Hungary :

- Őrizze meg az utasításokat későbbi használatra.
- Az összeszerelés során ügyeljen a becsípődés és a nyírás veszélyére.
- Tartsa távol a terméket hőforrásoktól.
- Ne üljön az ágyon többször.
- Ne ugorj az ágyra.
- Az ágyat száraz helyen tárolja.
- 4 év alatti gyermekek számára nem alkalmas.

Hrvatski :

- Sačuvajte upute za buduću upotrebu.
- Tijekom sastavljanja pazite na rizike od priklještenja i posjekotine.
- Proizvod držite podalje od izvora topline.
- Ne sjedite nekoliko puta na krevetu.
- Ne skačite po krevetu.
- Krevet čuvajte na suhom mjestu.
- Nije prikladno za djecu mlađu od 4 godina.

عربي :

احتفظ بالتعليمات للرجوع إليها في المستقبل
أثناء التجميع ، احذر من مخاطر القرص والقص
احتفظ بالمنتج بعيداً عن مصادر الحرارة
لا تجلس على السرير عدة
لا تقفز على السرير
قم بتخزين السرير في مكان جاف
سنوات 4 غير مناسب للأطفال دون سن

FR ATTENTION :

Age minimum : 4 ans.
Poids maximum : 50kg.
Le toboggan est destiné à une utilisation intérieure uniquement.
Attention. Réservé à un usage familial.

EN WARNING :

Minimum age: 4 years old.
Maximum weight: 50kg.
The slide is intended for indoor use only.
Warning. For family use only.

DE WARNUNG :

Mindestalter: 4 Jahre alt.
Maximales Gewicht: 50 kg.
Der Schlitten ist nur für den Innenbereich bestimmt.
Warnung. Nur für Familien.

ES ATENCIÓN :

Edad mínima: 4 años.
Peso máximo: 50 kg.
El tobogán está diseñado para uso en interiores únicamente.
Atención. Solo para uso familiar.

NL WAARSCHUWING :

Minimumleeftijd: 4 jaar.
Maximaal gewicht: 50 kg.
De glijbaan is alleen bedoeld voor gebruik binnenshuis.
Waarschuwing. Alleen voor gezinsgebruik.

IT AVVERTIMENTO :

Età minima: 4 anni.
Peso massimo: 50 kg.
Lo scivolo è inteso solo per uso interno.
Avvertimento. Solo per uso familiare.

PT AVISO :

Idade mínima: 4 anos.
Peso máximo: 50kg.
O slide é destinado apenas para uso interno.
Aviso. Apenas para uso familiar.

HU FIGYELMEZTETÉS:

Minimális életkor: 4 éves.
Maximális súly: 50 kg.
A csúszda beltéri használatra készült
Csak használatra.
Figyelem. Csak családi használatra.

CR UPOZORENJE:

Minimalna dob: 4 godine.
Maksimalna težina: 50 kg.
Tobogan je namijenjen za unutarnju upotrebu
koristiti samo.
Upozorenje. Samo za obiteljsku upotrebu.

AR تحذير :

الحد الأدنى للسّن: 4 سنوات.
الوزن الأقصى: 50 كجم.
الشريحة مخصصة للاستخدام الداخلي فقط.
تحذير . للاستخدام العائلي فقط.

**FRANCAIS: / IMPORTANT – LIRE ATTENTIVEMENT – À CONSERVER POUR RÉFÉRENCE
ULTÉRIEURE**

- a) Installer le lit et toboggan sur une surface horizontale en prévoyant une zone minimale de 1 m entre celui-ci et toute structure ou obstacle tel qu'une armoire ; etc. ;
- b) Le lit et toboggan ne doit pas être installés sur du béton ou tout autre revêtement en dur .
- c) Le toboggan ne doit pas être modifié et aucun accessoire ne doit être ajouté, cela pourrait être dangereux.
- d) Vérifier régulièrement que tous les éléments de fixation sont correctement serrés. e) vérifier tous les caches des boulons ou des bords coupants et les remplacer si nécessaire ;
- f) remplacer les éléments défectueux conformément aux instructions du fabricant;

ENGLISH: / IMPORTANT – READ CAREFULLY – RETAIN FOR FUTURE REFERENCE

- a) The bed and slide must be installed on a horizontal surface with a minimum distance of 1 m between the bed and any structure or obstacle such as a cabinet, etc;
- b) The bed and slide must not be installed on concrete or any other hard surface.
- c) The slide must not be modified and no accessories must be added, as this could be dangerous.
- d) Regularly check that all fasteners are properly tightened.
- e) Check all bolt covers or sharp edges and replace them if necessary;
- f) Replace defective components according to the manufacturer's instructions

**DEUTSCH : / WICHTIG - AUFMERKSAM LESEN - ZUR SPÄTEREN EINSICHTNAHME
AUFZUBEWAHREN**

- a) Das Bett und der Schlitten müssen auf einer horizontalen Fläche mit einem Mindestabstand von 1 m zwischen dem Bett und einer Struktur oder einem Hindernis wie einem Schrank usw. aufgestellt werden;
- b) Das Bett und der Schlitten dürfen nicht auf Beton oder einer anderen harten Oberfläche aufgestellt werden.
- c) Die Rutsche darf nicht verändert werden und es darf kein Zubehör hinzugefügt werden, da dies gefährlich sein könnte.
- d) Überprüfen Sie regelmäßig, ob alle Befestigungselemente richtig angezogen sind. e) Überprüfen Sie alle Schraubenabdeckungen oder scharfen Kanten und ersetzen Sie diese gegebenenfalls;
- f) Ersetzen Sie defekte Teile nach den Anweisungen des Herstellers.

ESPAÑOL: / IMPORTANTE - LEER CON ATENCION -CONSERVAR PARA FUTURAS ERENCIAS

- a) La cama y el tobogán deben instalarse en una superficie horizontal con una distancia mínima de 1 m entre la cama y cualquier estructura u obstáculo como un armario, etc;
- b) La cama y el tobogán no deben instalarse sobre hormigón o cualquier otra superficie dura.
- c) El tobogán no debe modificarse ni añadirse ningún accesorio, ya que podría ser peligroso.
- d) Compruebe regularmente que todas las fijaciones están bien apretadas.
- e) Compruebe todas las tapas de los tornillos o los bordes afilados y sustitúyalos si es necesario;
- f) Sustituya los componentes defectuosos según las instrucciones del fabricante.

NEDERLANDS : / BELANGRIJK - AANDACHTIG LEZEN - TE BEWAREN VOOR LATERE ADPLEGING

- a) Het bed en de glijbaan moeten worden geïnstalleerd op een horizontaal oppervlak met een minimumafstand van 1 m tussen het bed en een structuur of obstakel zoals een kast, enz;
- b) Het bed en de glijbaan mogen niet op beton of een ander hard oppervlak worden geïnstalleerd.
- c) De glijbaan mag niet worden gewijzigd en er mogen geen accessoires worden toegevoegd, aangezien dit gevaarlijk kan zijn.
- d) Controleer regelmatig of alle bevestigingsmiddelen goed zijn vastgedraaid.
- e) Controleer alle boutdeksels of scherpe randen en vervang deze indien nodig;
- f) Vervang defecte onderdelen volgens de instructies van de fabrikant.

ITALY : / IMPORTANTE - LEGGERE ATTENTAMENTE - DA CONSERVARE PER UN'ULTERIORE CONSULTAZIONE

- a) Il letto e lo scivolo devono essere installati su una superficie orizzontale con una distanza minima di 1 m tra il letto e qualsiasi struttura o ostacolo come un armadio, ecc;
- b) Il letto e la guida non devono essere installati su cemento o qualsiasi altra superficie dura.
- c) La guida non deve essere modificata e non devono essere aggiunti accessori, in quanto ciò potrebbe essere pericoloso.
- d) Controllare regolarmente che tutti gli elementi di fissaggio siano ben serrati.
- e) Controllare tutte le coperture dei bulloni o i bordi taglienti e sostituirli se necessario;
- f) Sostituire i componenti difettosi secondo le istruzioni del produttore.

PORTUGUÊS: / IMPORTANTE – LEIA ATENTAMENTE – GARDE PARA REFERÊNCIA FUTURA

- a) A cama e o escorregador devem ser instalados em uma superfície horizontal com distância mínima de 1 m entre a cama e qualquer estrutura ou obstáculo como armário, etc;
- b) A cama e o escorregador não devem ser instalados sobre concreto ou qualquer outra superfície dura.
- c) A corrediça não deve ser modificada e nenhum acessório deve ser adicionado, pois isso pode ser perigoso.
- d) Verifique regularmente se todos os fixadores estão bem apertados.
- e) Verifique todas as tampas dos parafusos ou arestas vivas e substitua-as se necessário;
- f) Substitua os componentes defeituosos de acordo com as instruções do fabricante

HUNGARY : / FONTOS – OLVASSA EL FIGYELMESEN – ŐRIZZE MEG A KÉSŐBBI HSZNÁLATHOZ

- a) Az ágyat és a csúszdát vízszintes felületre kell felszerelni úgy, hogy az ágy és bármilyen szerkezet vagy akadály, például szekrény stb. között legalább 1 m távolság legyen;
- b) Az ágyat és a csúszdát nem szabad betonra vagy más kemény felületre felszerelni.
- c) A csúszdát nem szabad módosítani, és semmilyen kiegészítőt nem szabad hozzáadni, mert ez veszélyes lehet.
- d) Rendszeresen ellenőrizze, hogy minden rögzítőelem megfelelően meg van-e húzva.
- e) Ellenőrizze az összes csavarfedelelet vagy éles szélét, és szükség esetén cserélje ki őket;
- f) Cserélje ki a hibás alkatrészeket a gyártó utasításai szerint

HRVATSKI : / VAŽNO – PAŽLJIVO PROČITAJTE – ZADRŽITE ZA BUDUĆU REFERENCU

- a) Krevet i tobogan moraju biti postavljeni na vodoravnu površinu s minimalnom udaljenosti od 1 m između kreveta i bilo koje strukture ili prepreke kao što je ormarić, itd.;
- b) Krevet i tobogan ne smiju se postavljati na beton ili bilo koju drugu tvrdu površinu.
- c) Tobogan se ne smije modificirati i ne smije se dodavati nikakav pribor jer bi to moglo biti opasno.
- d) Redovito provjeravajte jesu li svi pričvršni elementi dobro zategnuti.
- e) Provjerite sve poklopce vijaka ili oštre rubove i zamijenite ih ako je potrebno;
- f) Zamijenite neispravne komponente prema uputama proizvođača

هام - اقرأ بعناية - احتفظ به للرجوع إليه في المستقبل / عربي

أ) يجب تثبيت السرير والشريحة على سطح أفقي بمسافة لا تقل عن 1 متر بين السرير وأي هيكل أو عائق مثل الخزانة وما إلى ذلك ؛

ب) يجب عدم تركيب الفرشة والشريحة على الخرسانة أو أي سطح صلب آخر

ج) يجب عدم تعديل الشريحة وعدم إضافة ملحقات ، فقد يكون ذلك خطيرًا

د) تحقق بانتظام من أن جميع أدوات التثبيت مشدودة بشكل صحيح

هـ) افحص جميع أغطية البراغي أو الحواف الحادة واستبدالها إذا لزم الأمر ؛

و) استبدل المكونات المعيبة وفقًا لتعليمات الشركة الصانعة

ب) يجب عدم تركيب الفرشة والشريحة على الخرسانة أو أي سطح صلب آخر

ج) يجب عدم تعديل الشريحة وعدم إضافة ملحقات ، فقد يكون ذلك خطيرًا







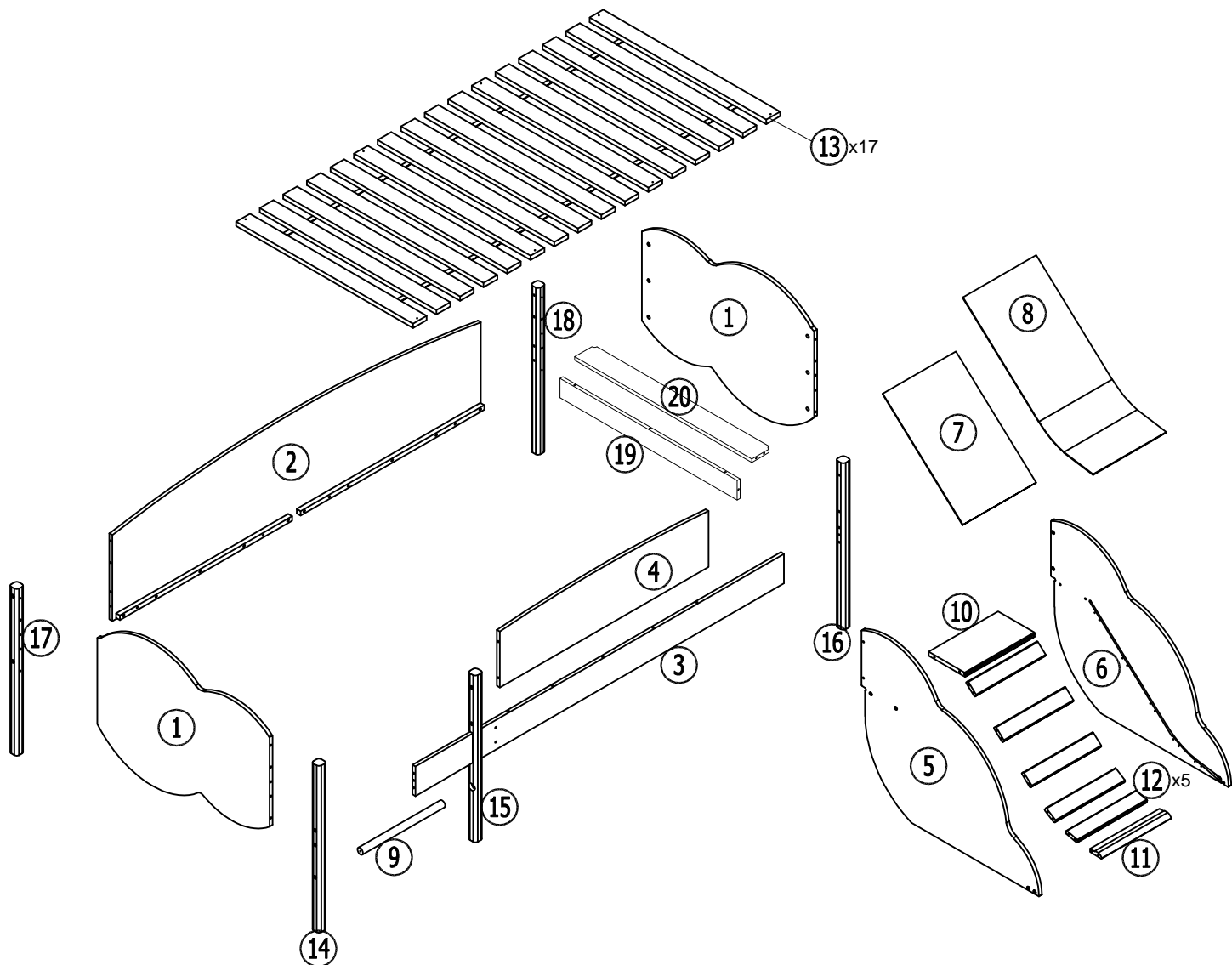

د) تحقق بانتظام من أن جميع أدوات التثبيت مشدودة بشكل صحيح



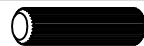

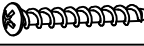

هـ) افحص جميع أغطية البراغي أو الحواف الحادة واستبدالها إذا لزم الأمر ؛

و) استبدل المكونات المعيبة وفقًا لتعليمات الشركة الصانعة



REF	Dimension (mm)	Qt'y	REF	Dimension (mm)	Qt'y	REF	Dimension (mm)	Qt'y
1	877*630*15	2	8	825*370*3	1	15	731*40*40	1
2	1977*460*15	1	9	372*Ø30	1	16	731*40*40	1
3	1977*130*15	1	10	354*187*18	1	17	731*40*40	1
4	1196*234*15	1	11	354*60*18	1	18	731*40*40	1
5	905*757*15	1	12	354*60*15	5	19	902*86*15	1
6	905*757*15	1	13	900*70*15	17	20	902*100*15	1
7	550*370*3	1	14	731*40*40	1			

ITEM	HARDWARE	DESCRIPTION	Q'TY
A		Ø5 x 45 mm	23 PCS
B		Ø14.5x11.9 mm	31 PCS
E		Ø8 x 30 mm	14 PCS
F		Ø6 x 30 mm	6 PCS
G			2 PCS
H		Ø4 X 30 mm	8 PCS
J		Ø6x50 mm	12 PCS
K		Ø6x70 mm	10 PCS
L		Ø9.5 x 11 mm	22 PCS

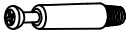
ITEM	HARDWARE	DESCRIPTION	Q'TY
M			5 PCS
N		Ø3 X 12 mm	2 PCS
Q		Ø6 x 70 mm	2 PCS
R		Ø6x30 mm	2 PCS
T		Ø6 x 20 mm	3 PCS
U		Ø6 x 45 mm	2 PCS
V		Ø5x42 mm	8 PCS

1

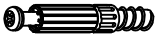
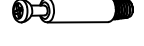
A	x20	V	x 8
	Ø5 x 45		Ø5x42 mm

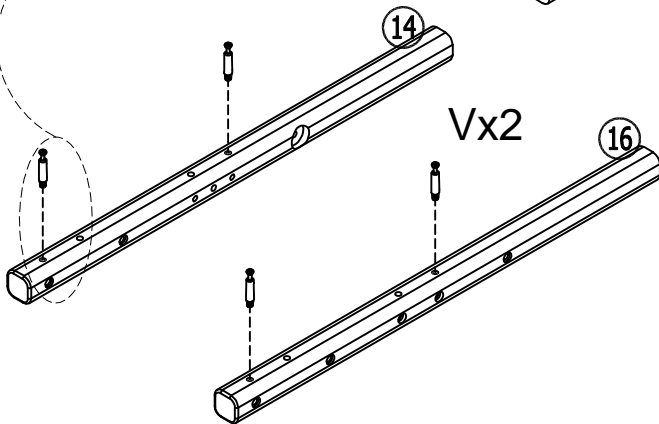
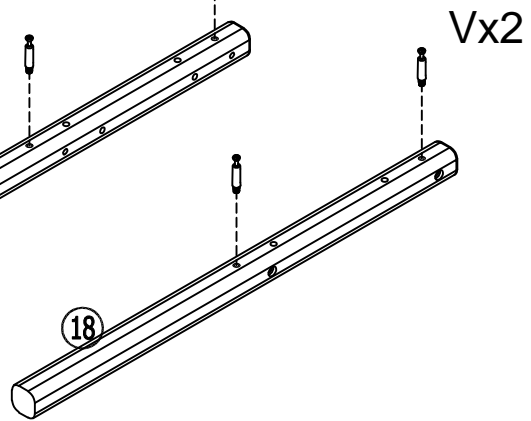
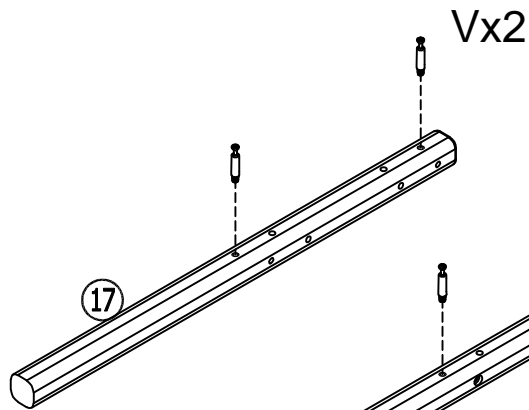
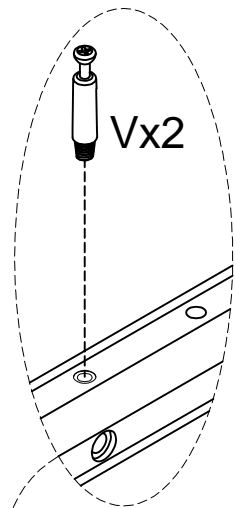
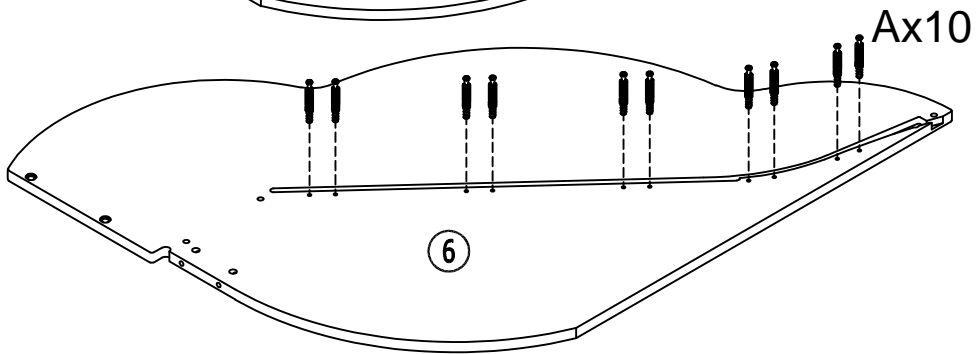
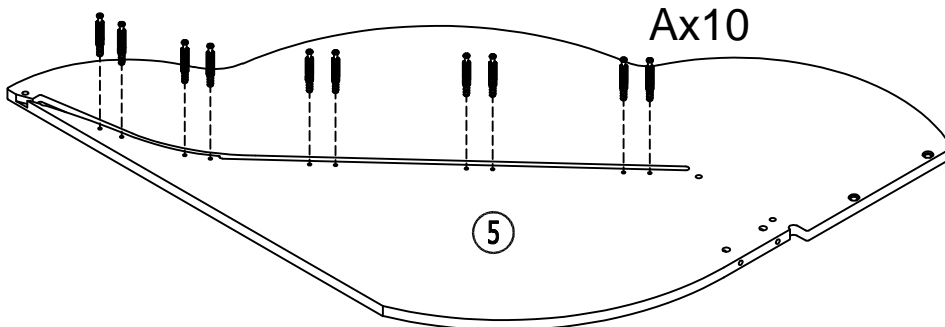
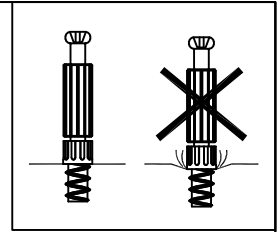

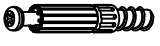
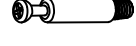

1

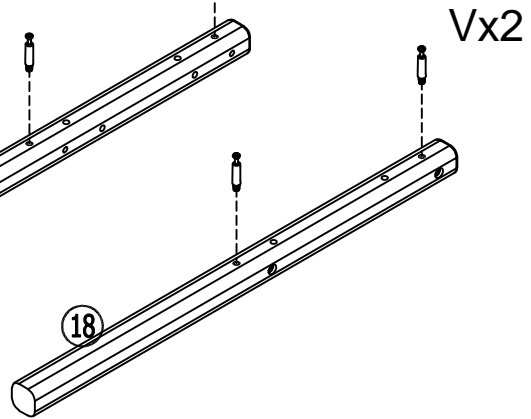
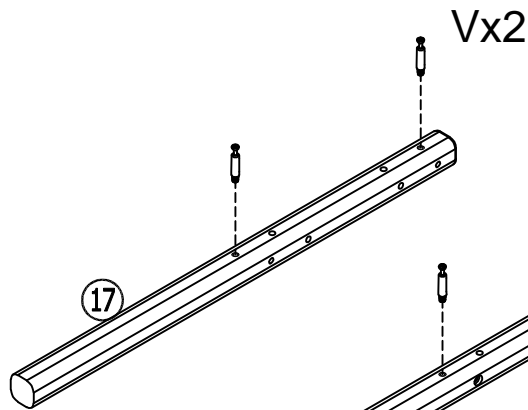
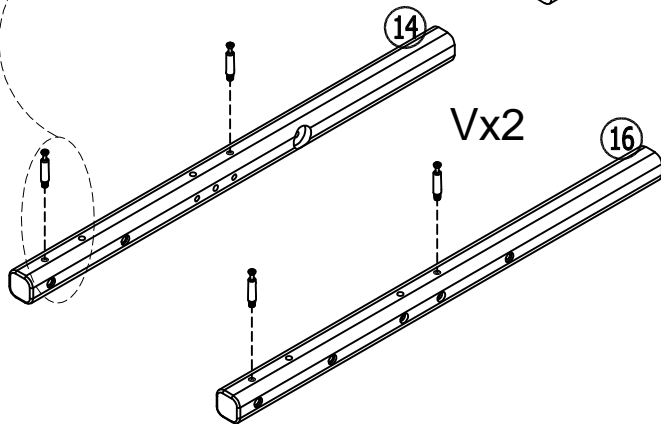
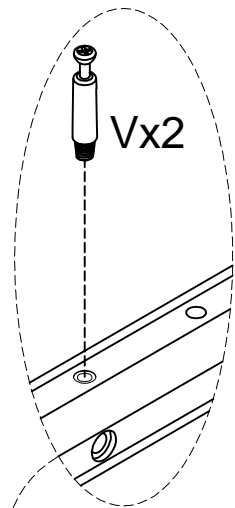
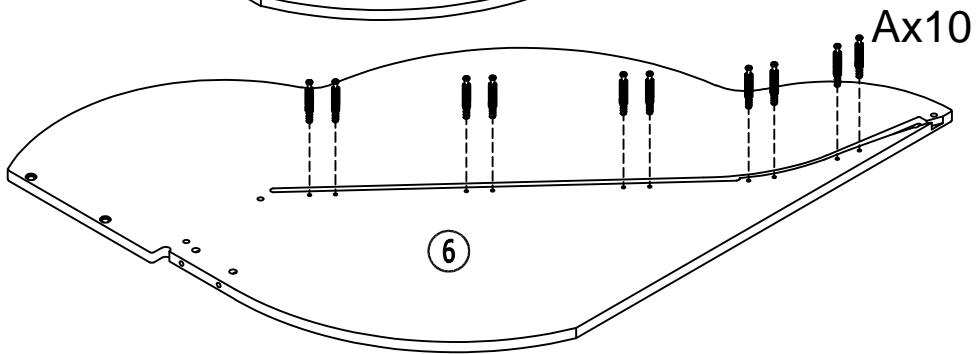
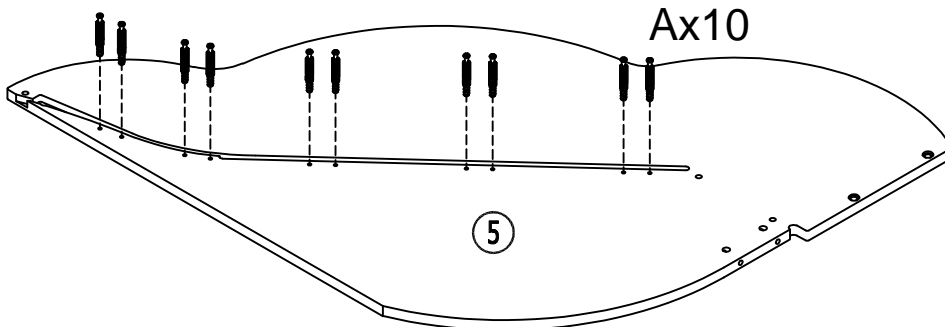
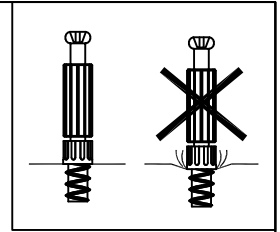
A	x20	V	x 8
	Ø5 x 45		Ø5x42 mm



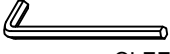

2

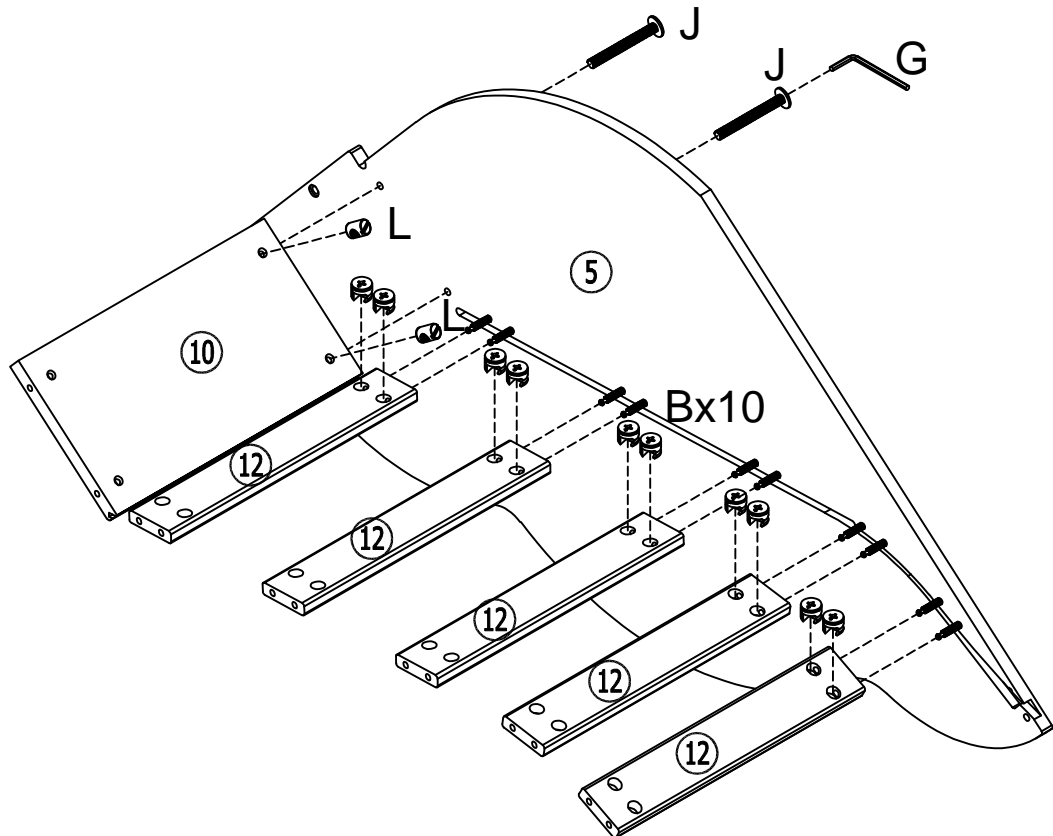
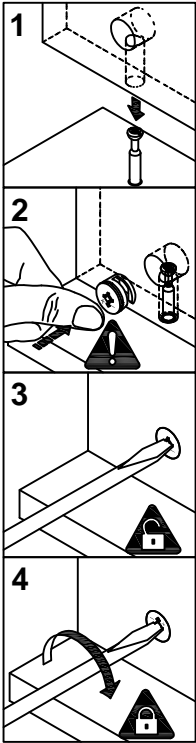
B	x10	J	x2	L	x2	G	x1
							
Ø14.5x11.9		Ø6x50		Ø9.5 x 11		CLEF ALLEN	

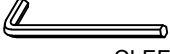

3

B	x10	J	x2	L	x2	G	x1
							
Ø14.5x11.9		Ø6x50		Ø9.5 x 11		CLEF ALLEN	

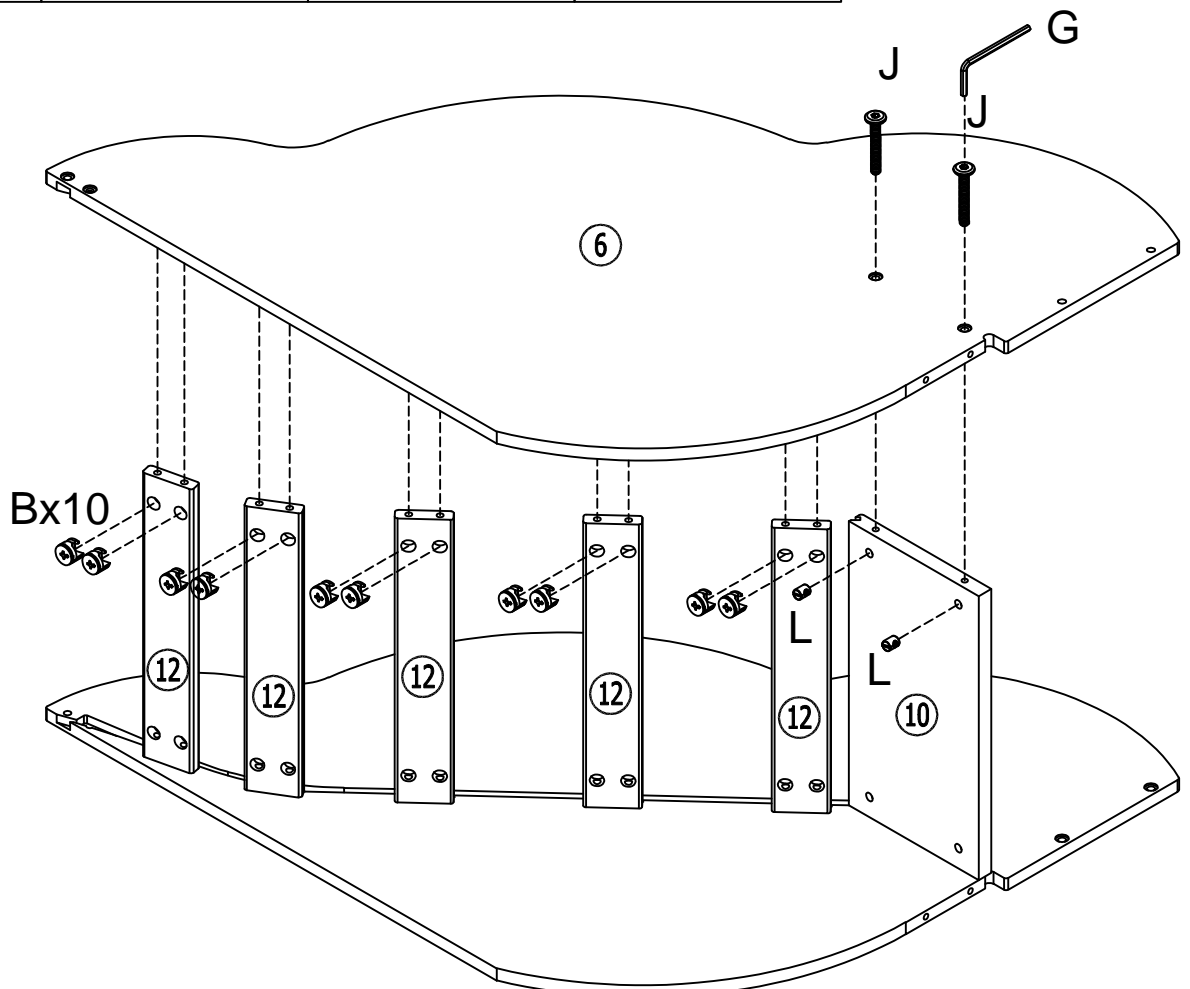
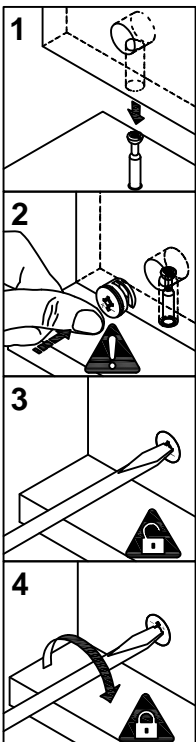

4

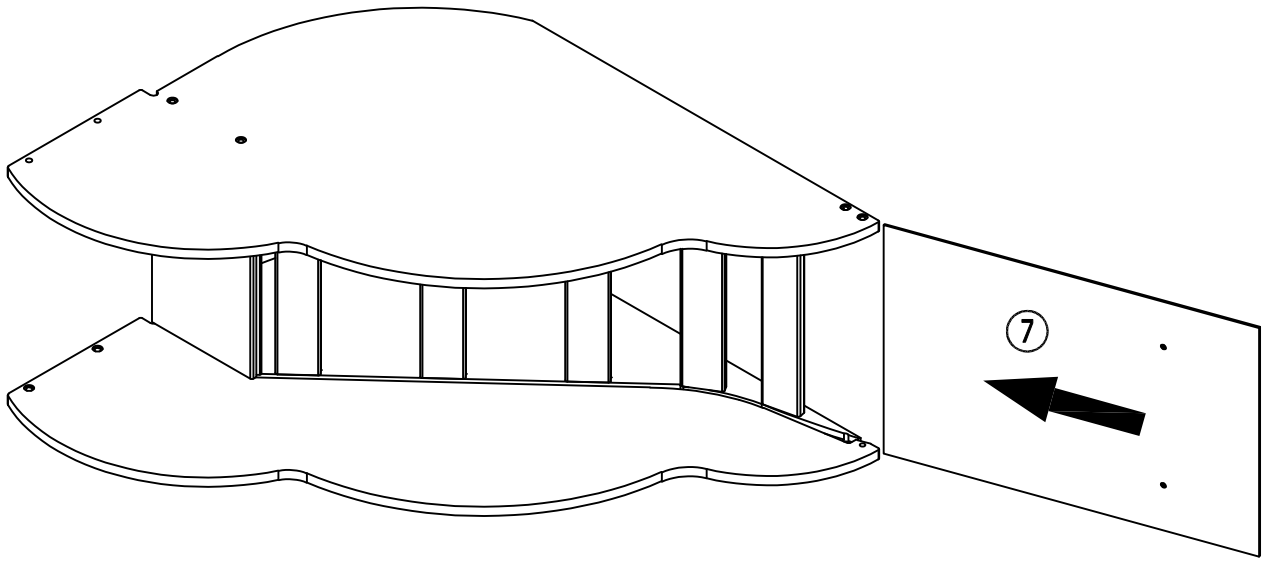

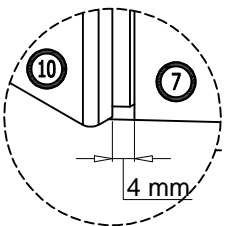
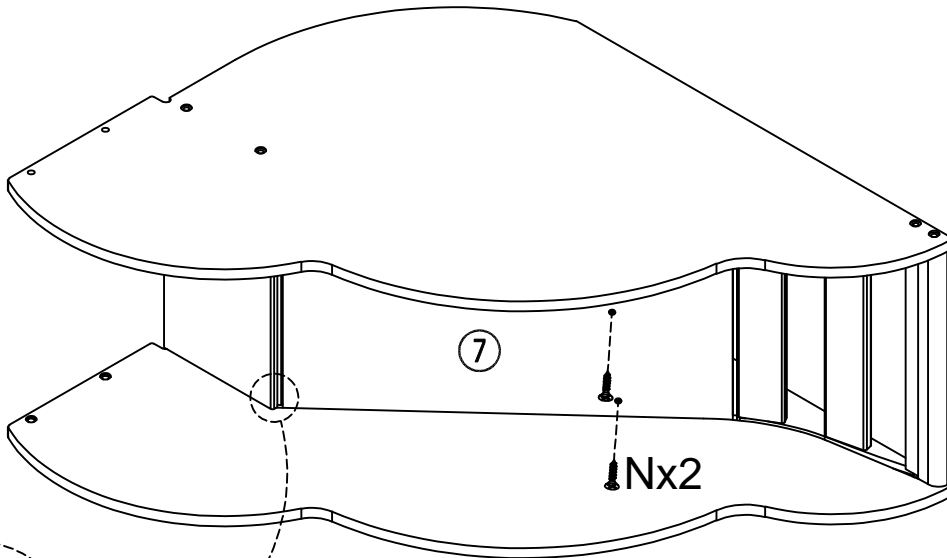
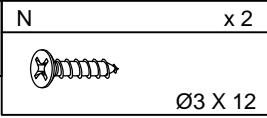

5

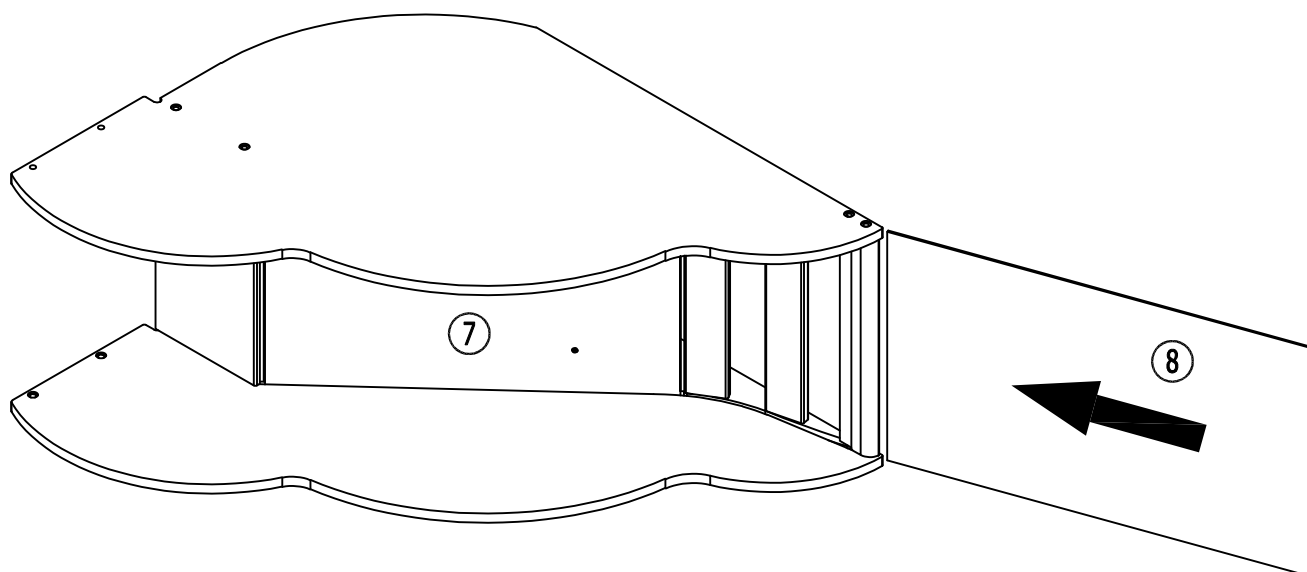

6



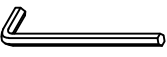

7

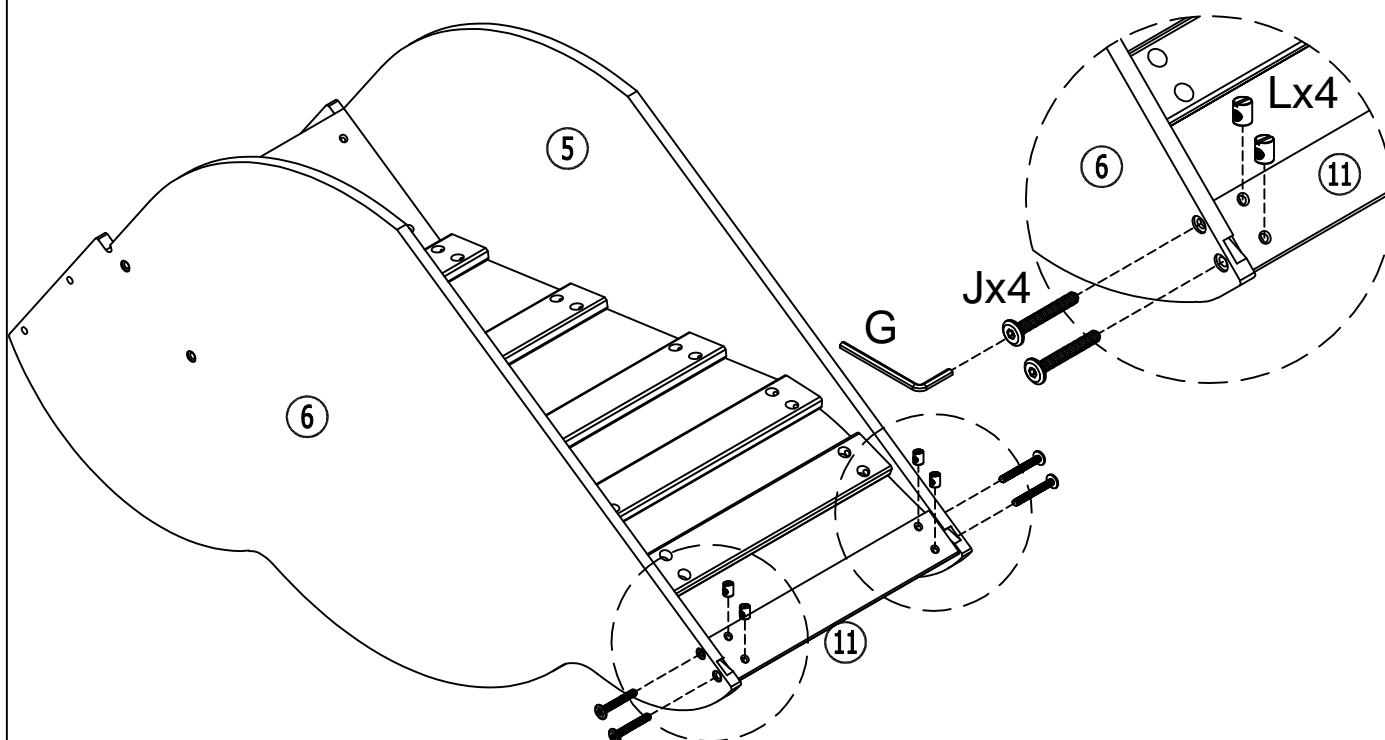
J	x4	L	x4	G	x1
					
	Ø6x50		Ø9.5 x 11		

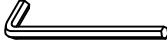

8

L	x 4	E	x 4	K	x 4	G	x 1
							
	Ø9.5 x 11		Ø8 x 30		Ø6x70		

Option 1

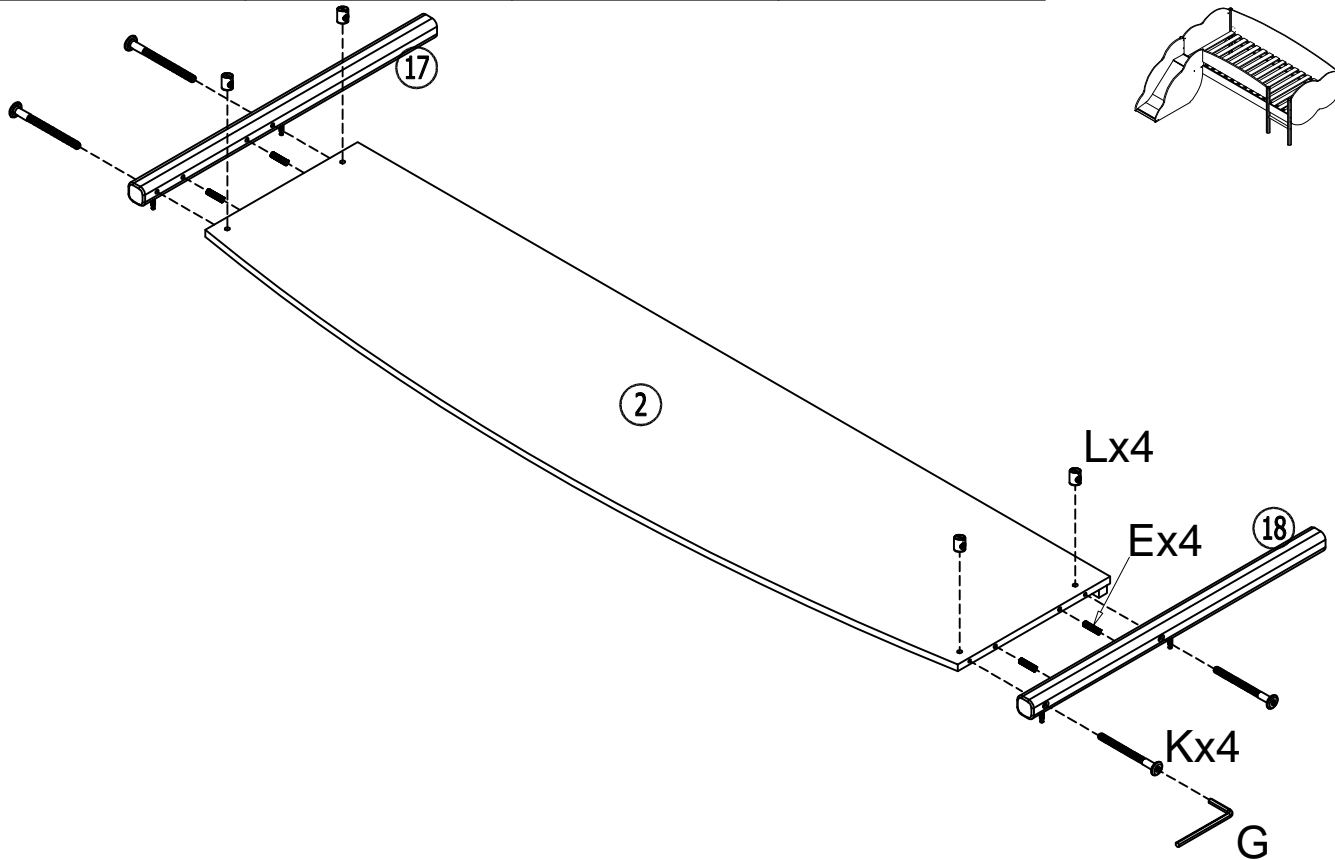
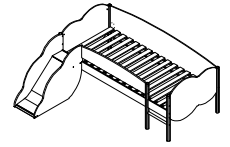

9

Q	x 1
	
	Ø6 x 70

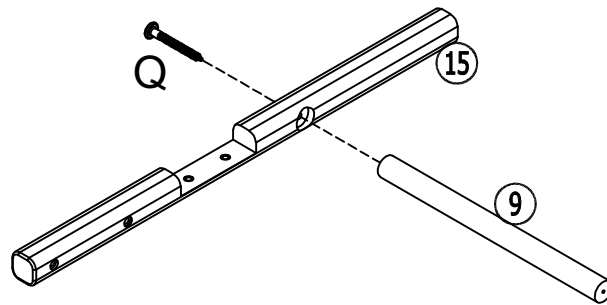





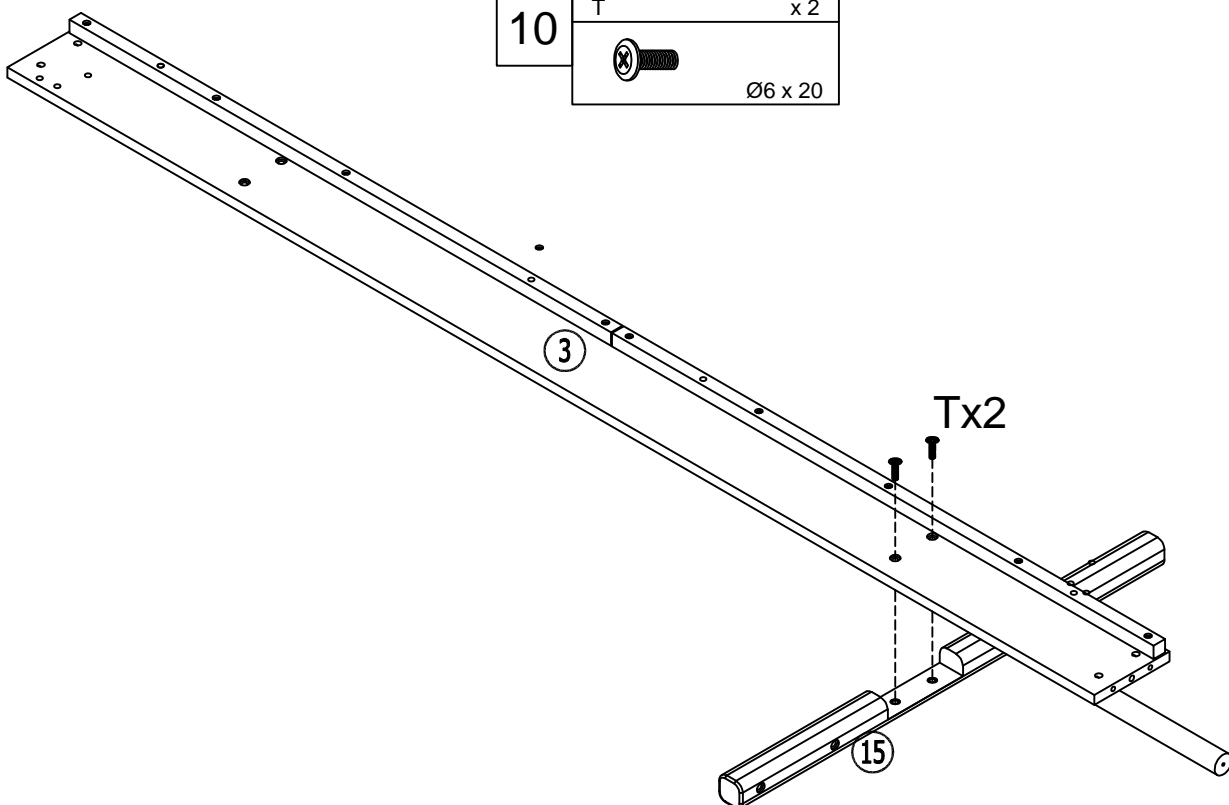

10

T	x 2
	
	Ø6 x 20

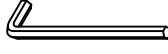

11

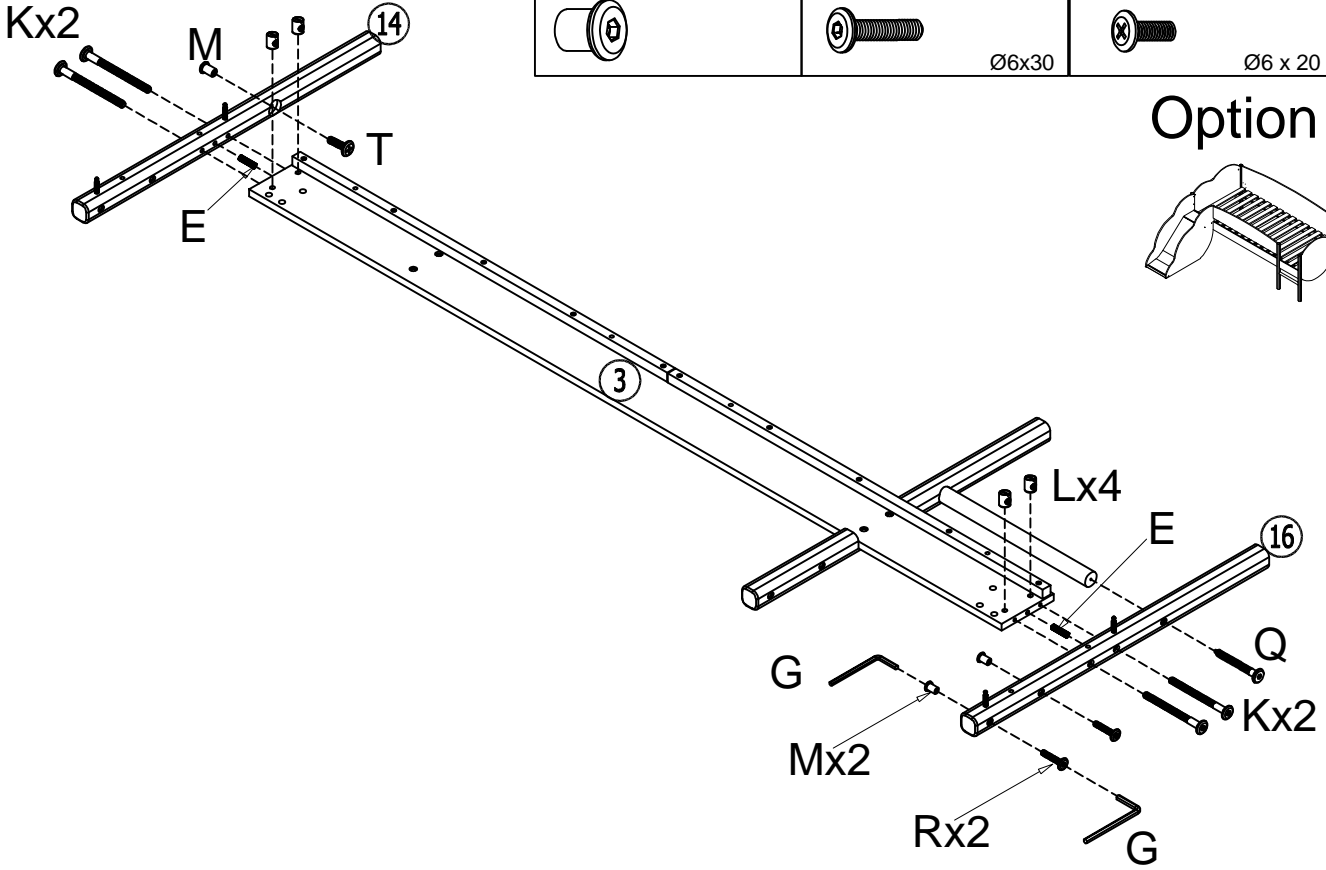

L	x 4	E	x 2	K	x 4	G	x 2	Q	x 1
									
	Ø9.5 x 11		Ø8 x 30		Ø6x70				Ø6 x 70
M	x 3	R	x 2	T	x 1				
									
			Ø6x30		Ø6 x 20				

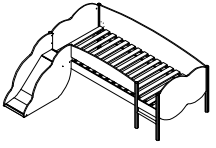

Option 1



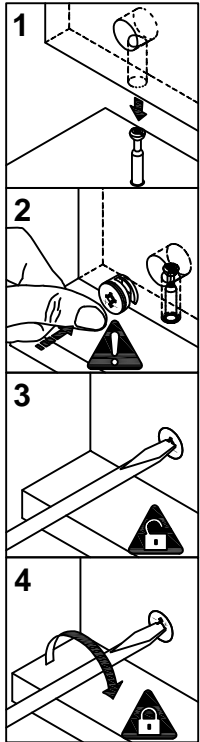
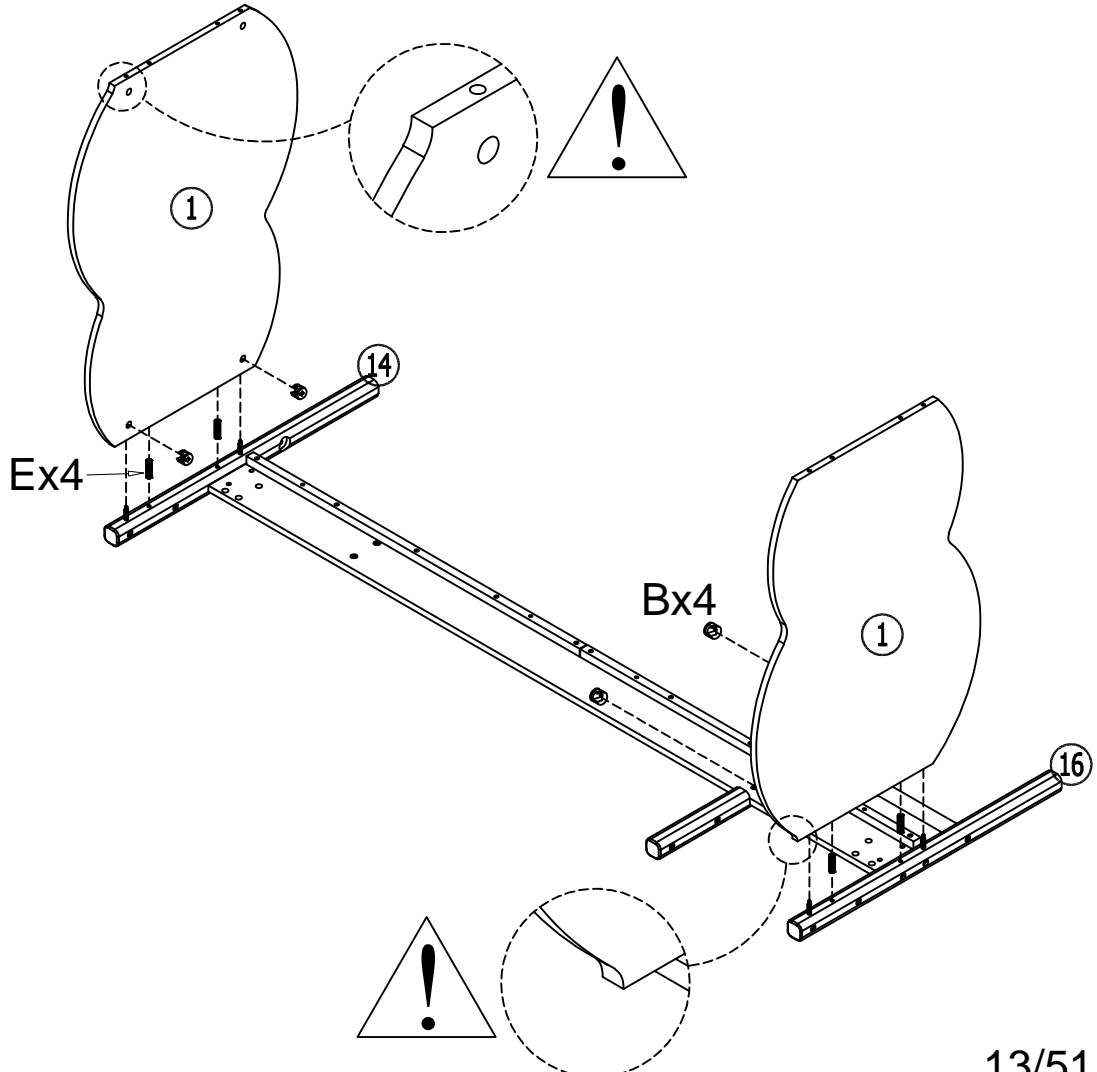

12

B	x 4
	
	Ø14.5x11.9
E	x 4
	
	Ø8 x 30





13

B	x4
	Ø14.5x11.9
E	x4
	Ø8 x 30

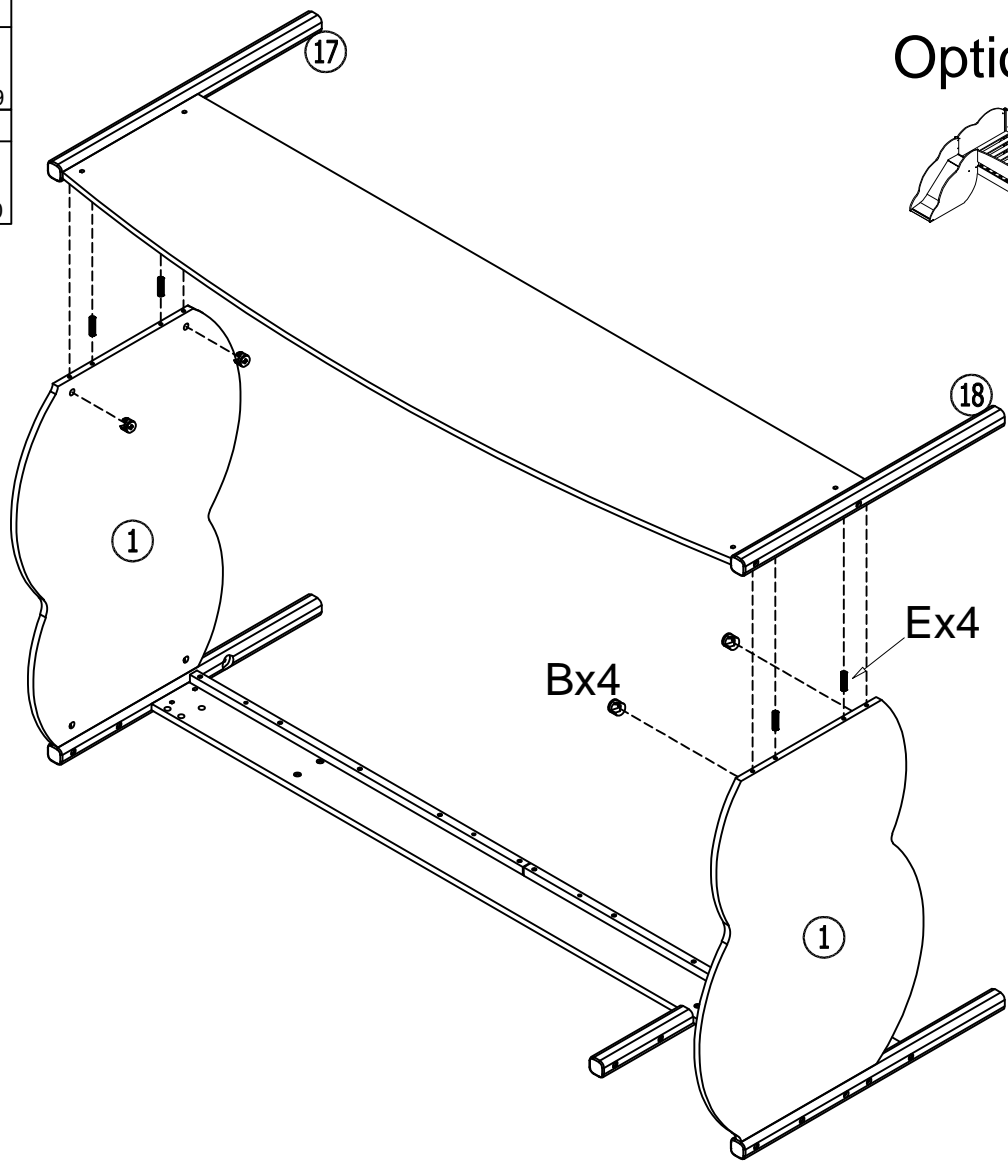
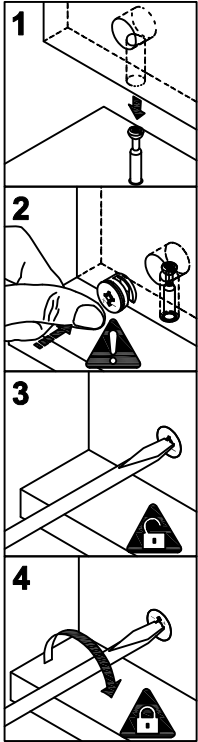
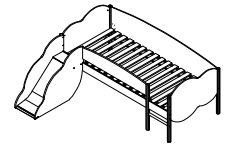
Option 1



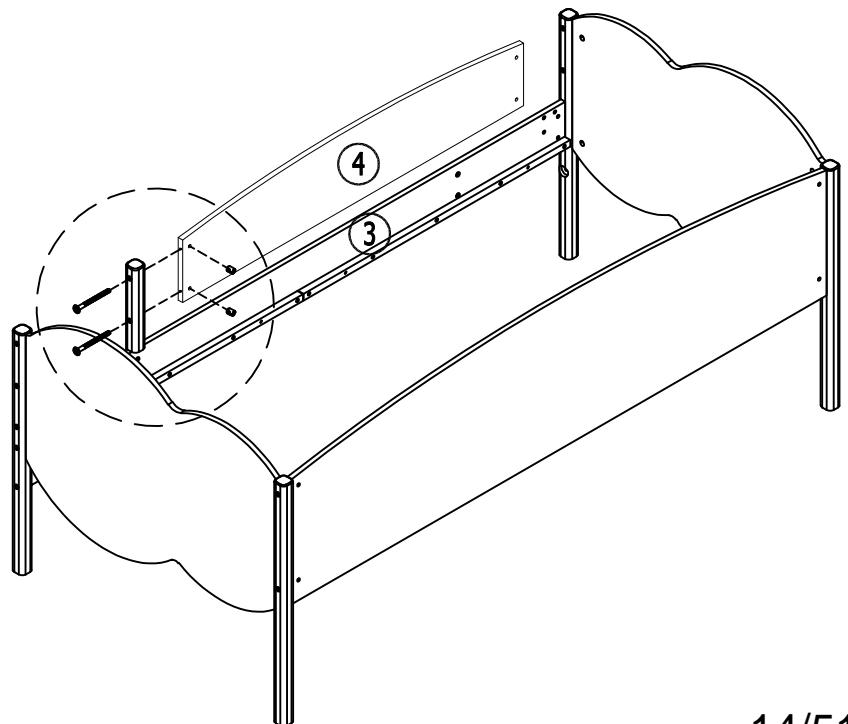
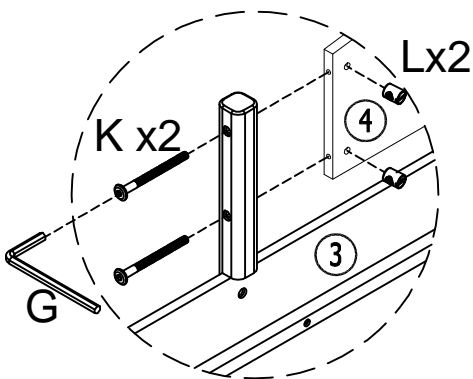

14

L	x2	K	x2	G	x1
	Ø9.5 x 11		Ø6x70		





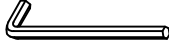

15

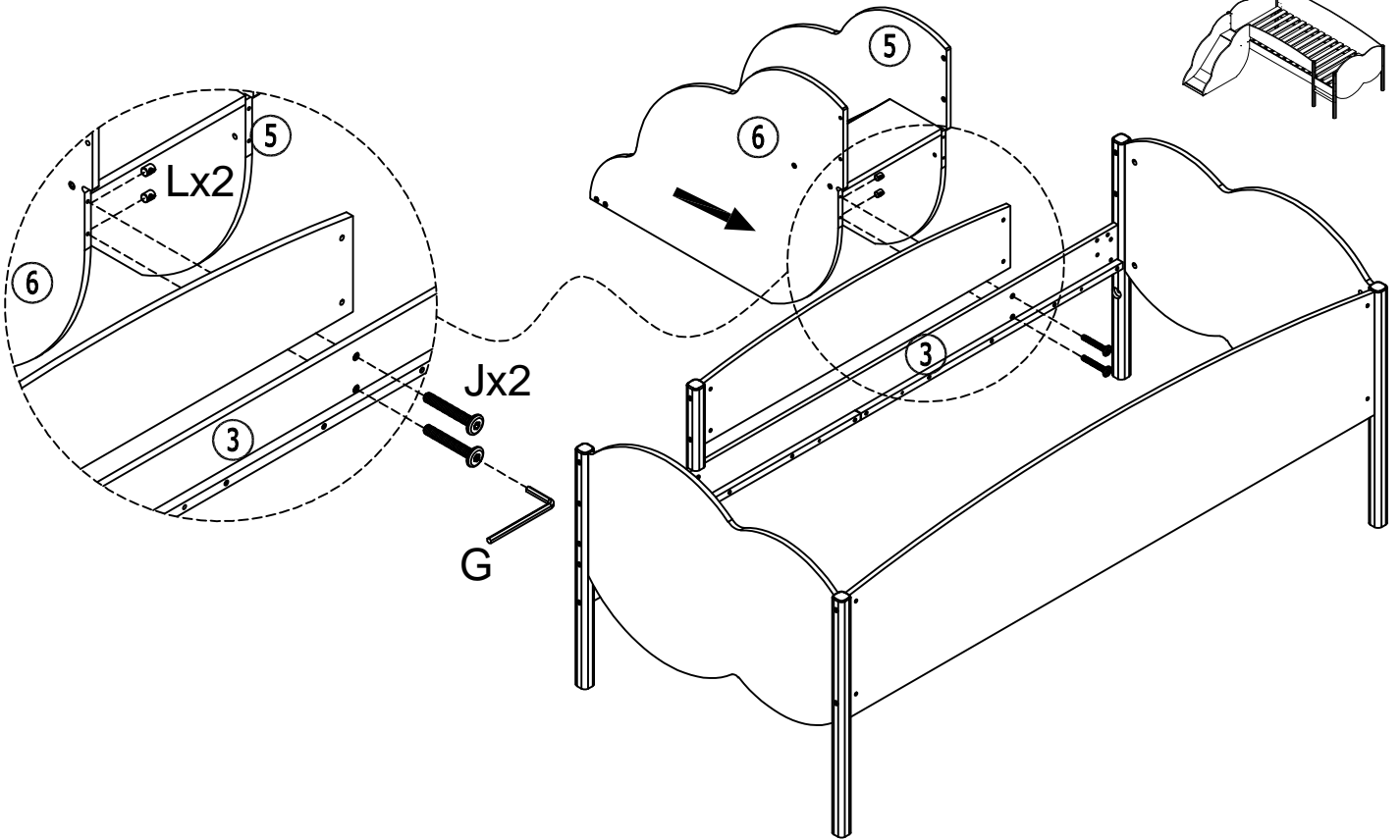
L	x2	J	x2	G	x1
					
Ø9.5 x 11		Ø6x50			

Option 1

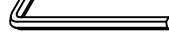

16

L	x2	J	x2	M	x2	G	x2	U	x2
									
Ø9.5 x 11		Ø6x50						Ø6x45	

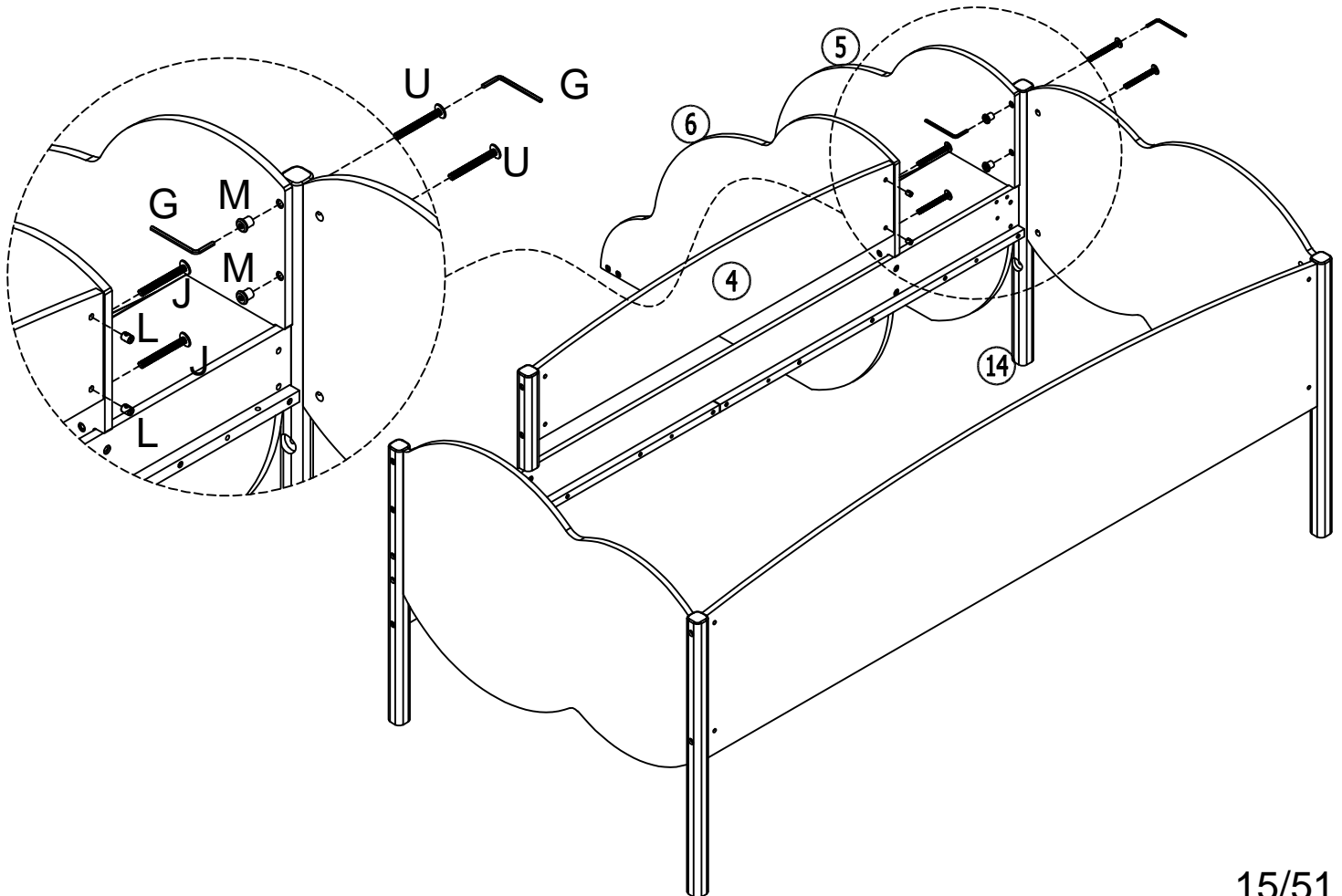

17

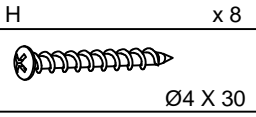



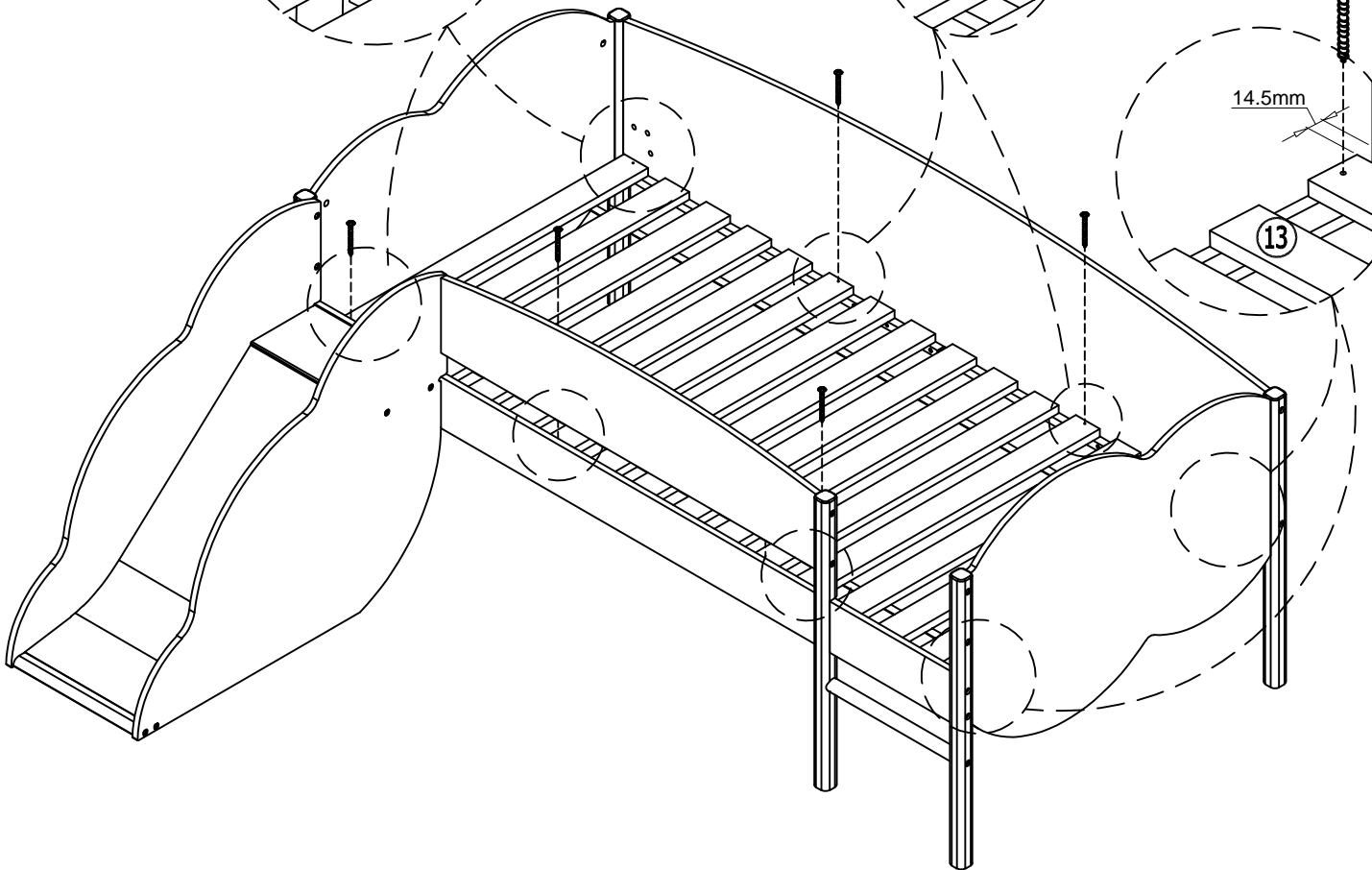
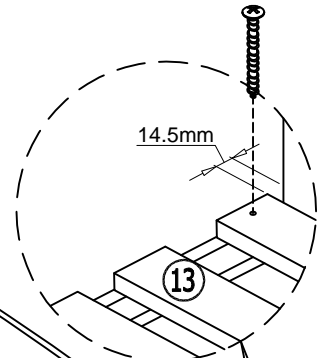
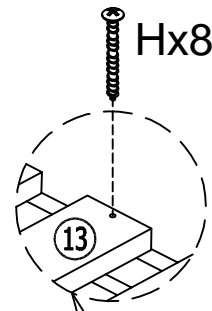
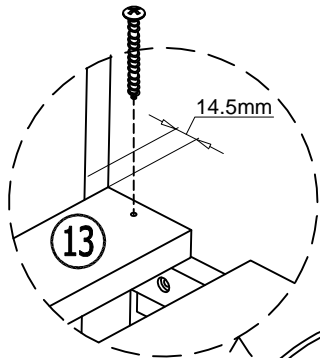
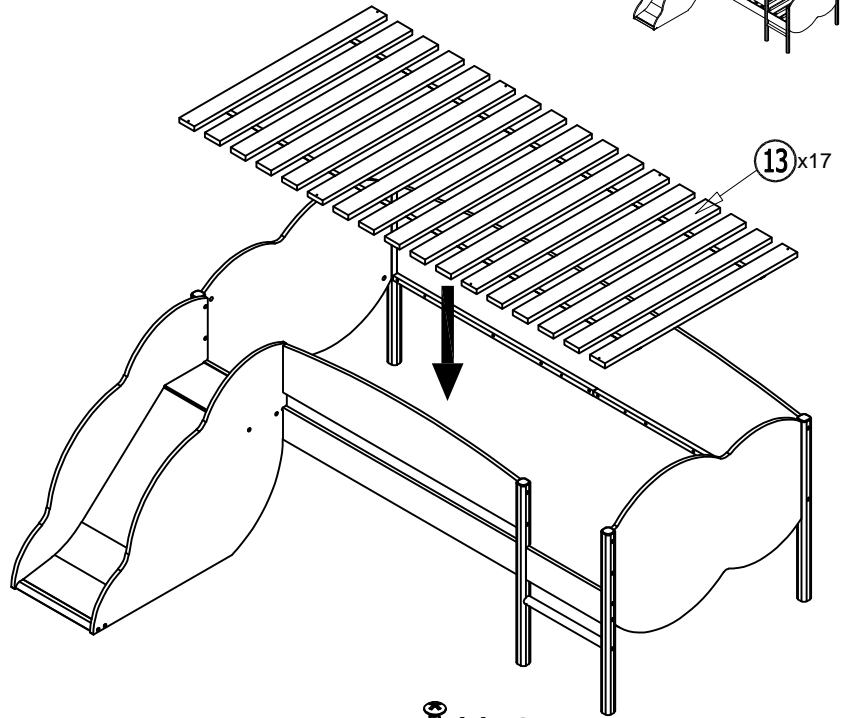
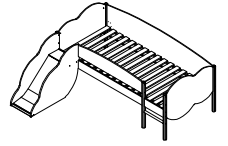

Option 1

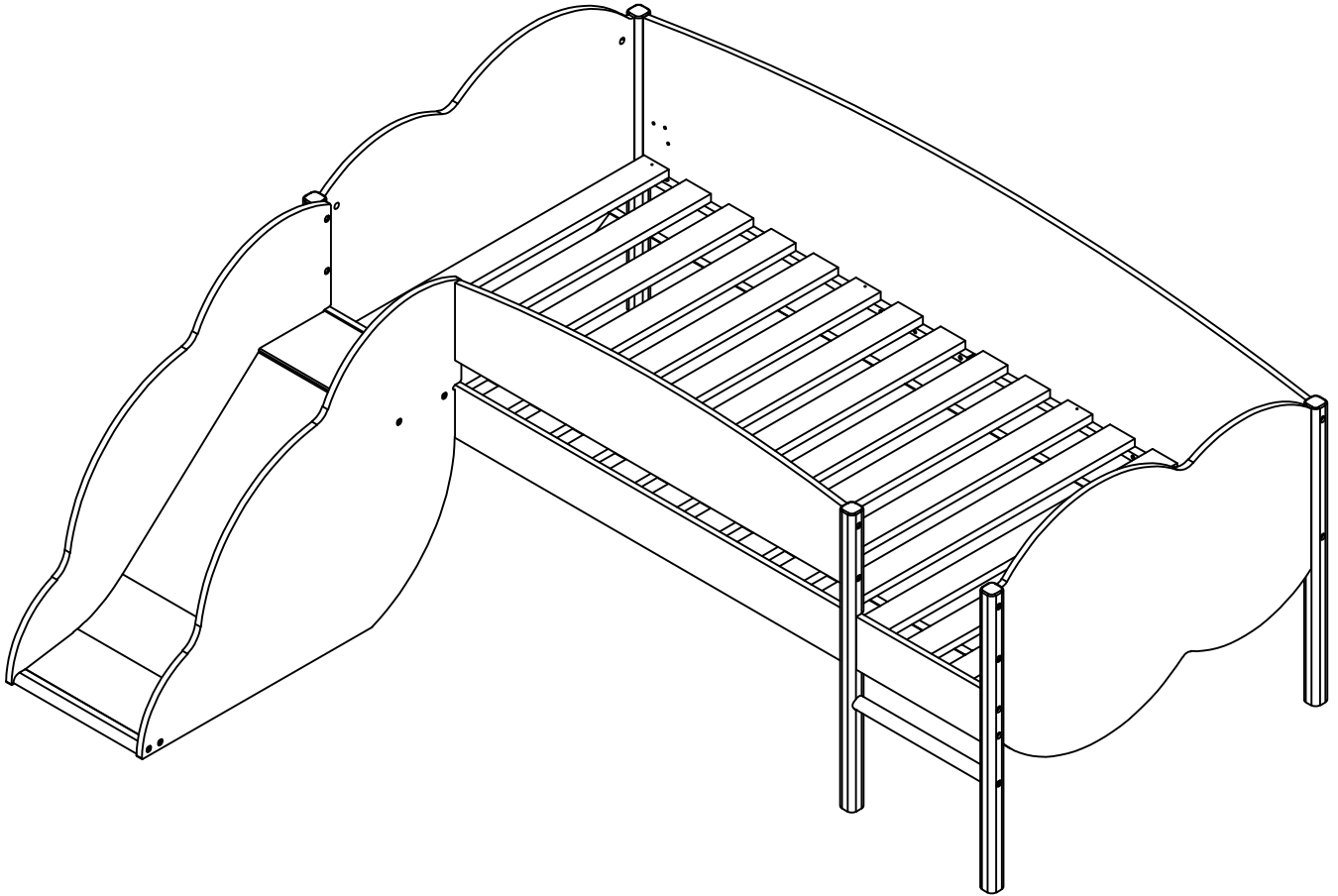

End Option 1



8

L	x 4	E	x 4	K	x 4	G	x 1
							
Ø9.5 x 11		Ø8 x 30		Ø6x70			

Option 2

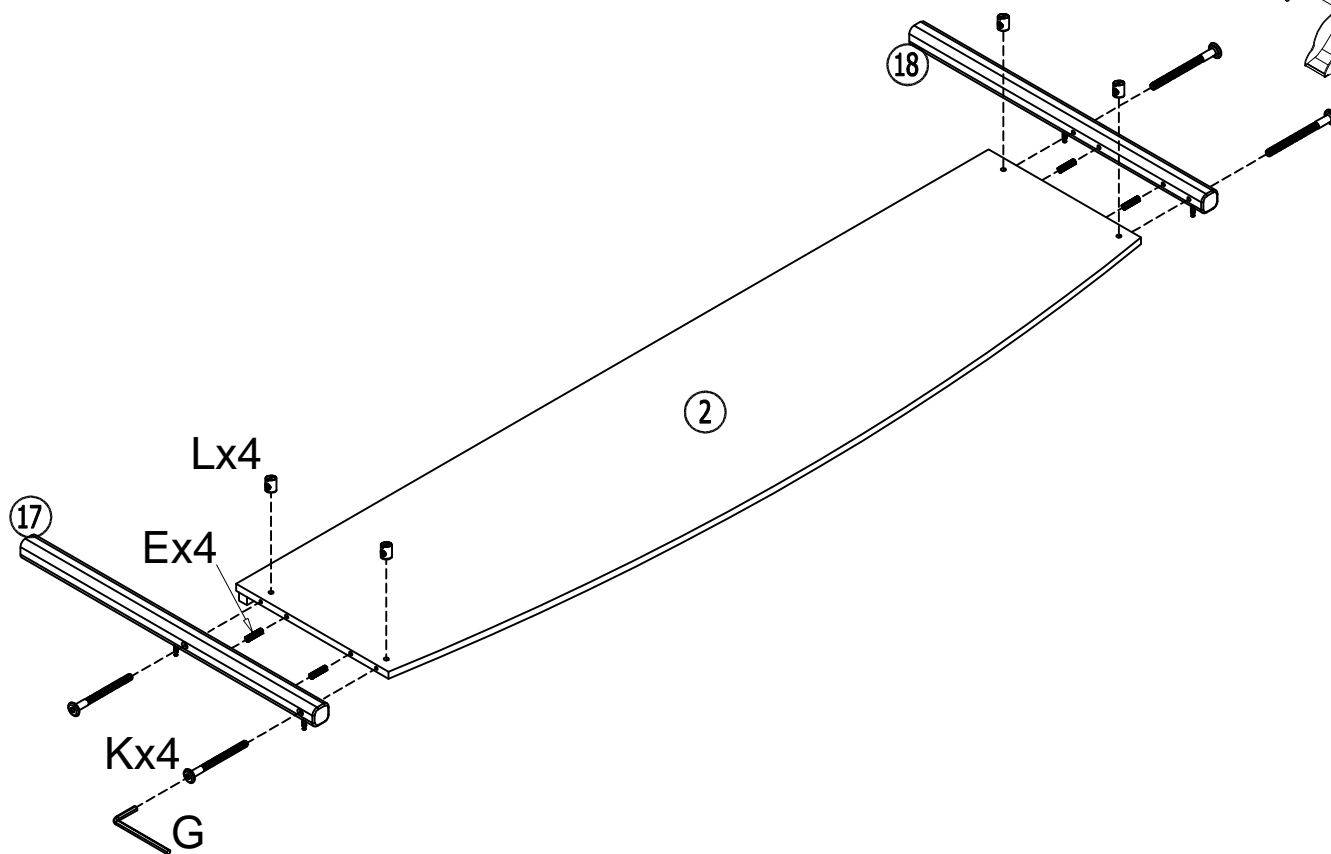
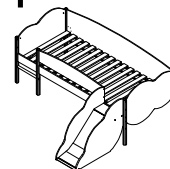

9

Q	x 1
	
Ø6 x 70	

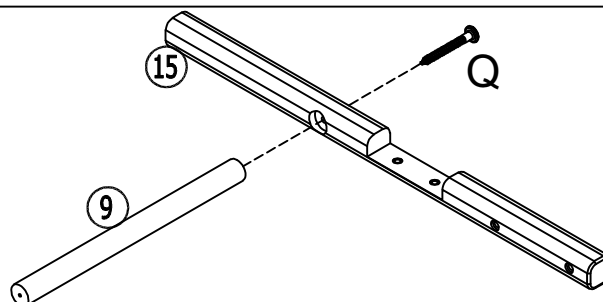





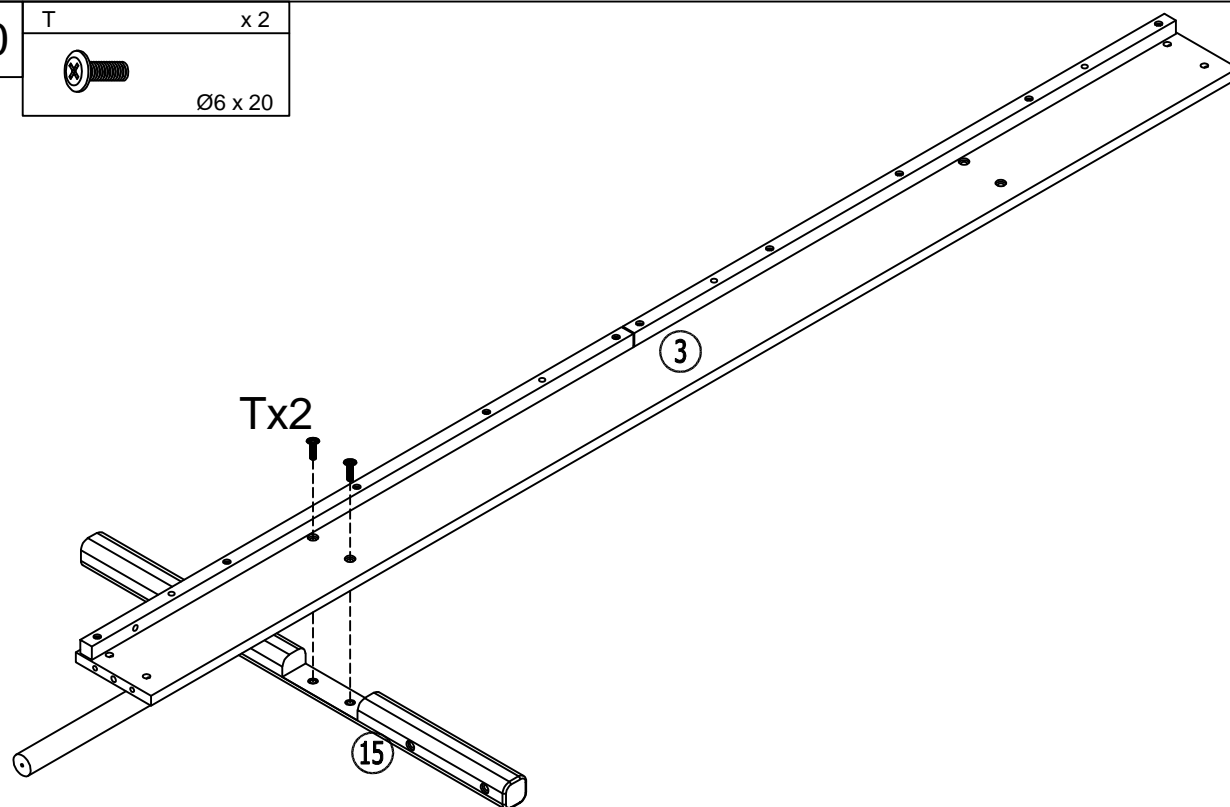

10

T	x 2
	
Ø6 x 20	

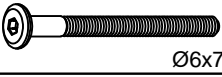
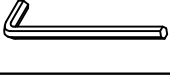

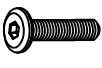

11

L	x 4	E	x 2	K	x 4	G	x 2
	Ø9.5 x 11		Ø8 x 30		Ø6x70		
M	x 3	R	x 2	T	x 1	Q	x 1
			Ø6x30		Ø6 x 20		Ø6 x 70

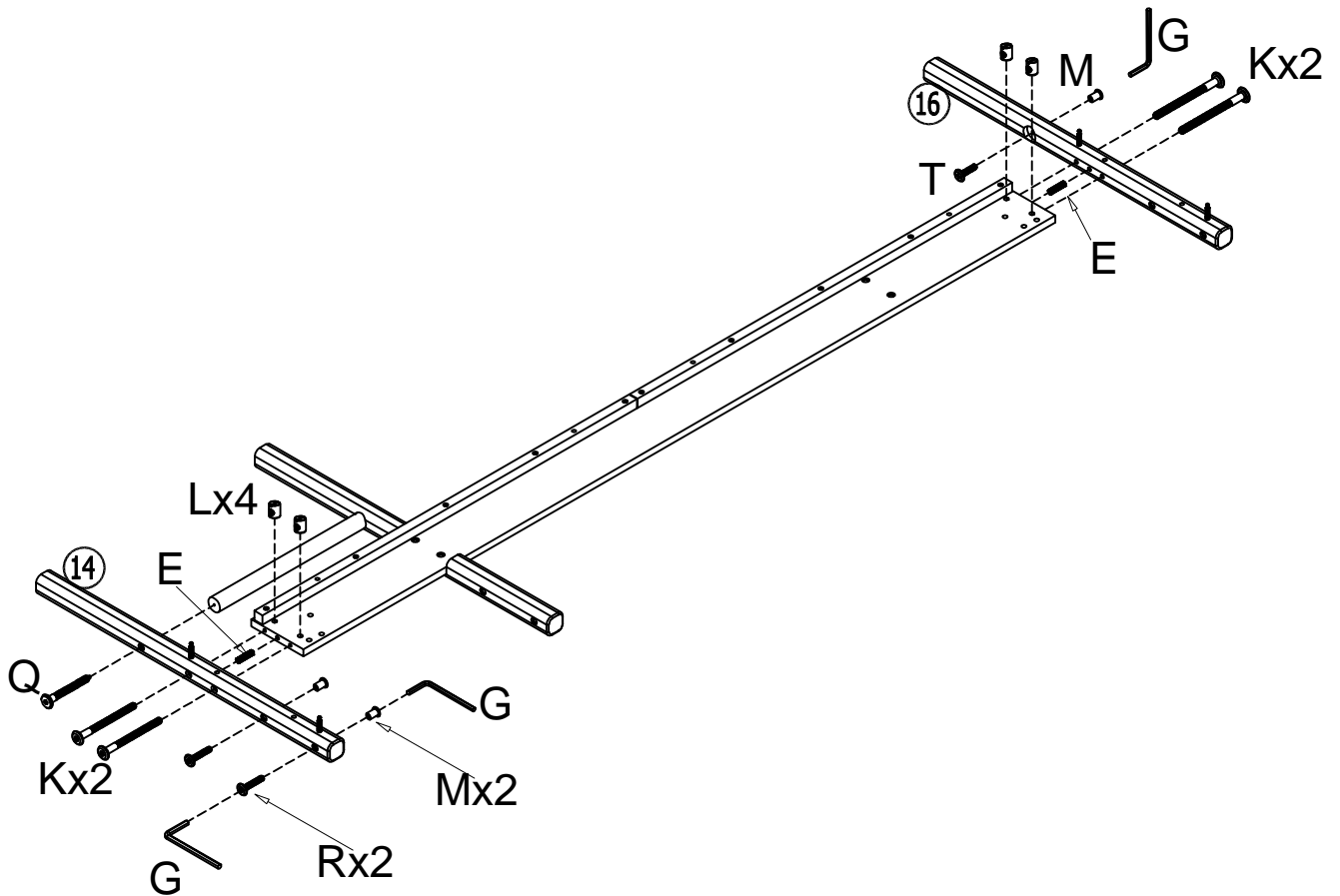
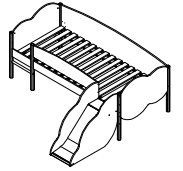
Option 2



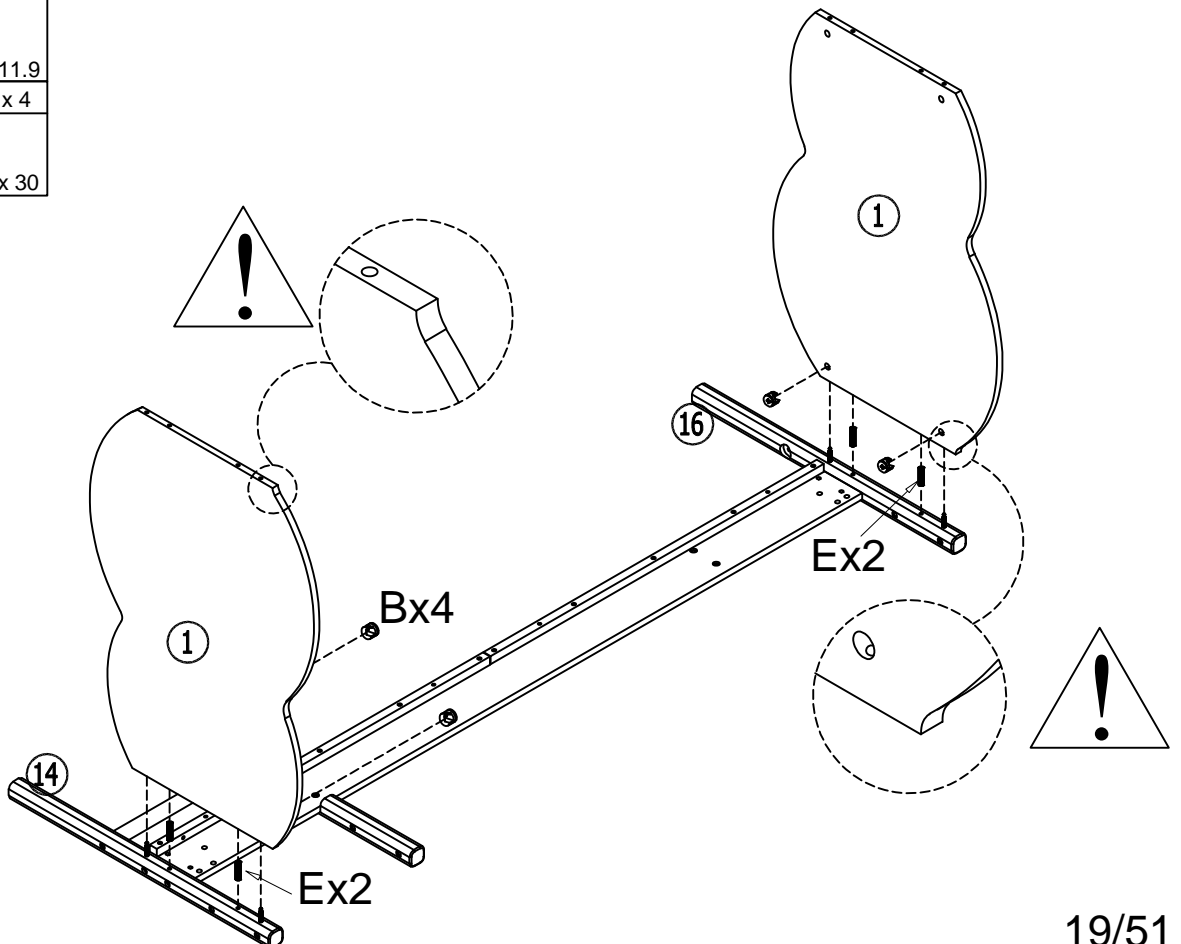
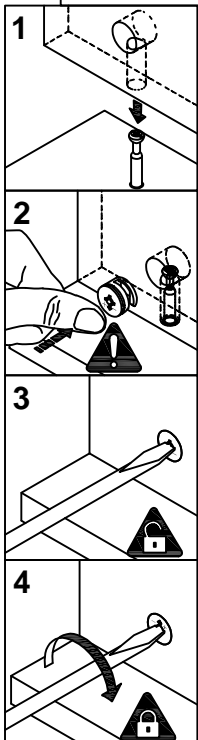

12

B	x 4
	Ø14.5x11.9
E	x 4
	Ø8 x 30





13

B	x4
	Ø14.5x11.9
E	x4
	Ø8 x 30

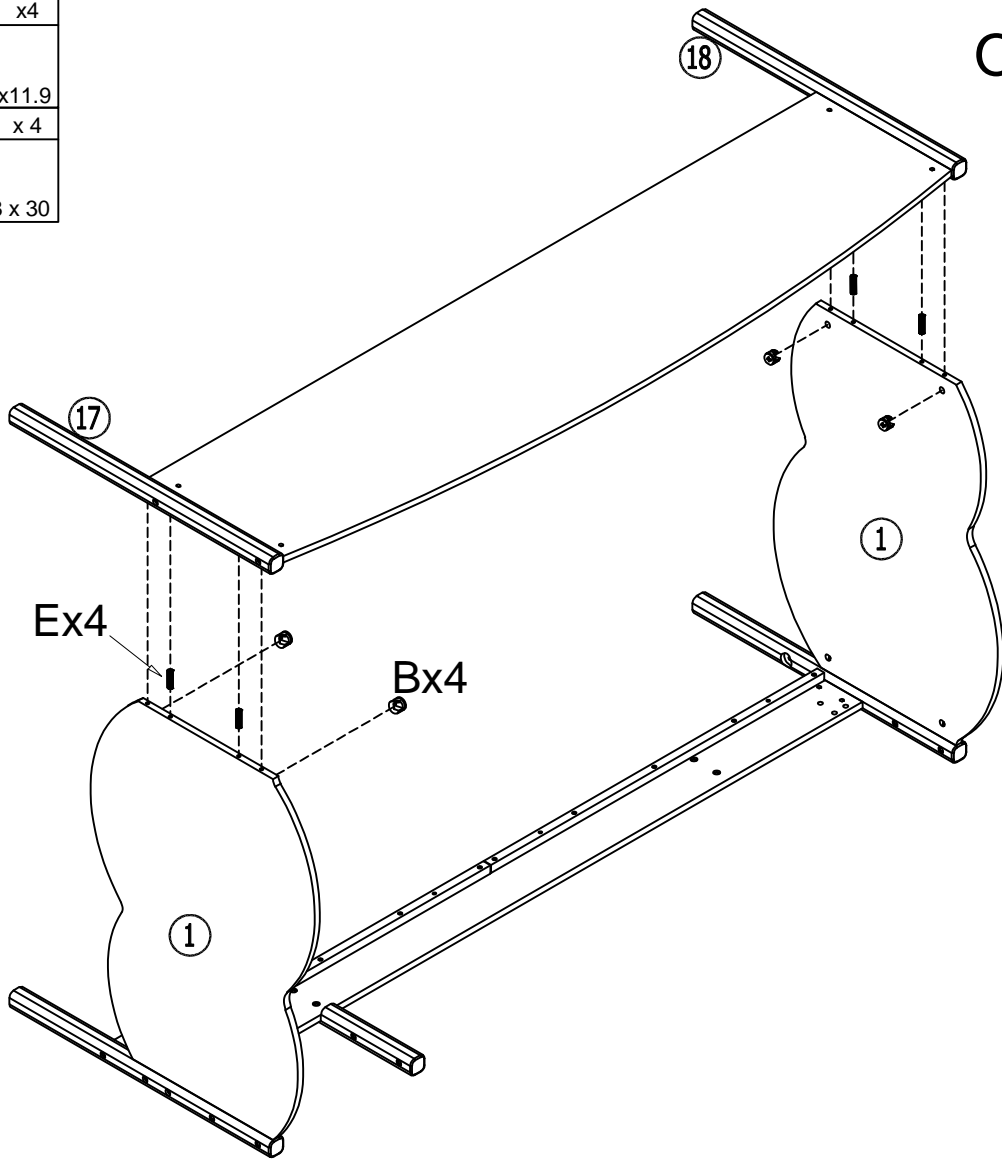
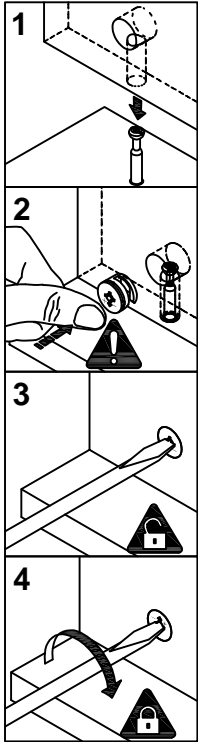
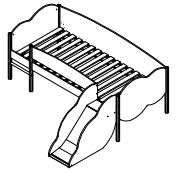
Option 2



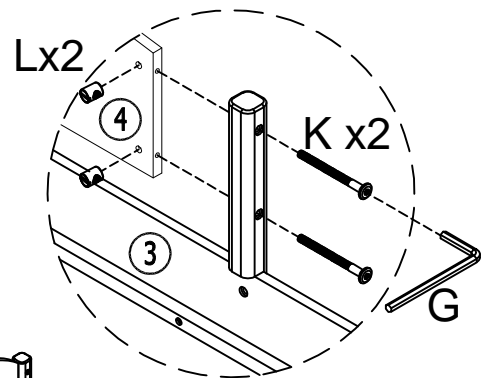
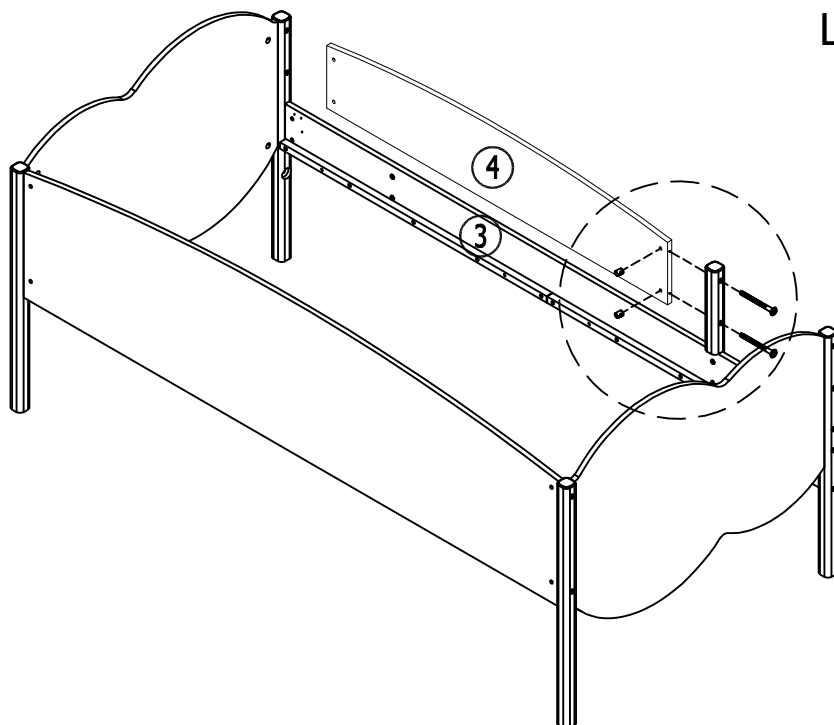

14

L	x2	K	x2	G	x1
	Ø9.5 x 11		Ø6x70		



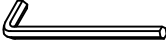

14

L	x2	J	x2	G	x1
					
Ø9.5 x 11		Ø6x50			

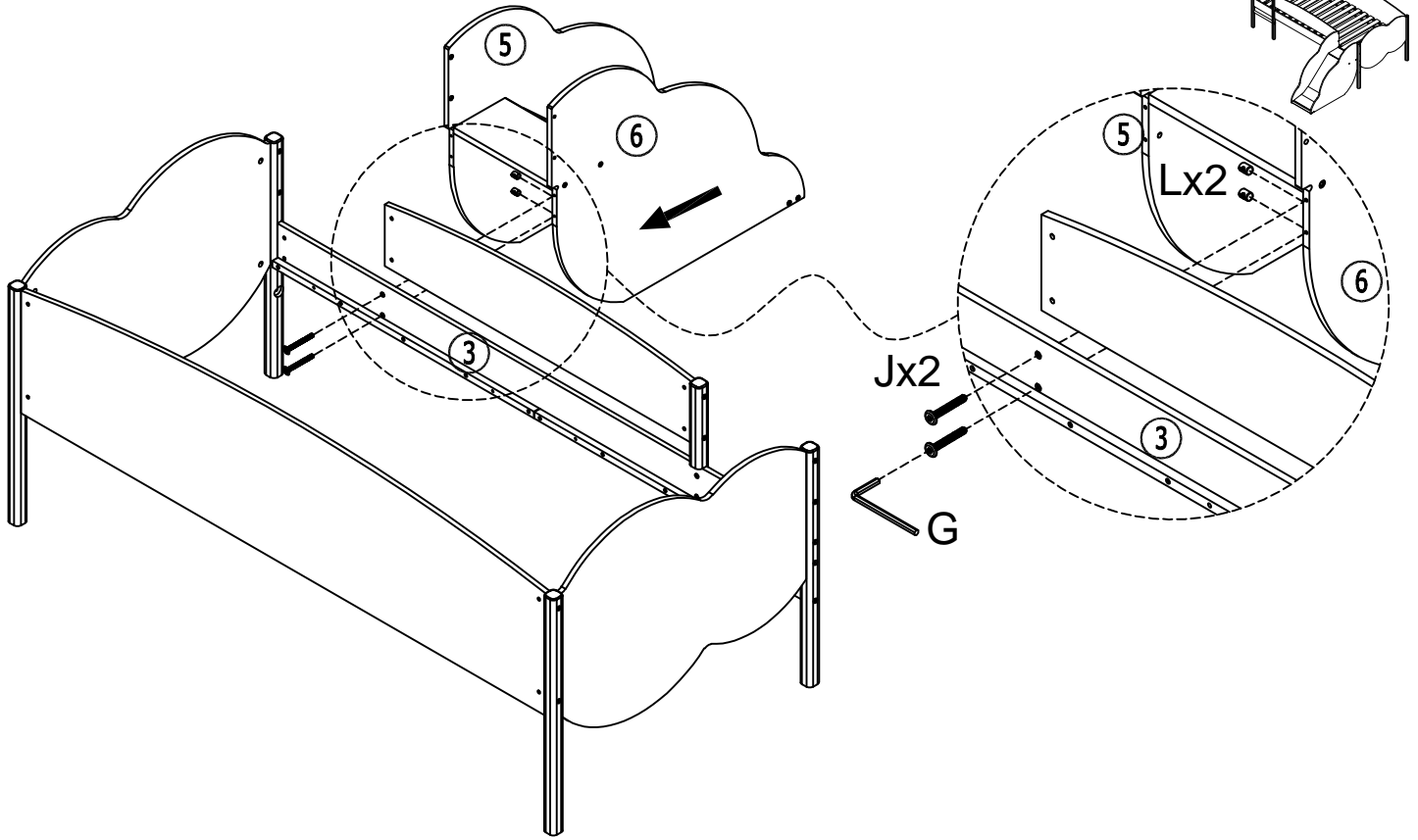
Option 2

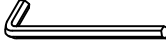
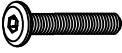

15

L	x2	J	x2	M	x2	G	x2	U	x2
									
Ø9.5 x 11		Ø6x50						Ø6x45	

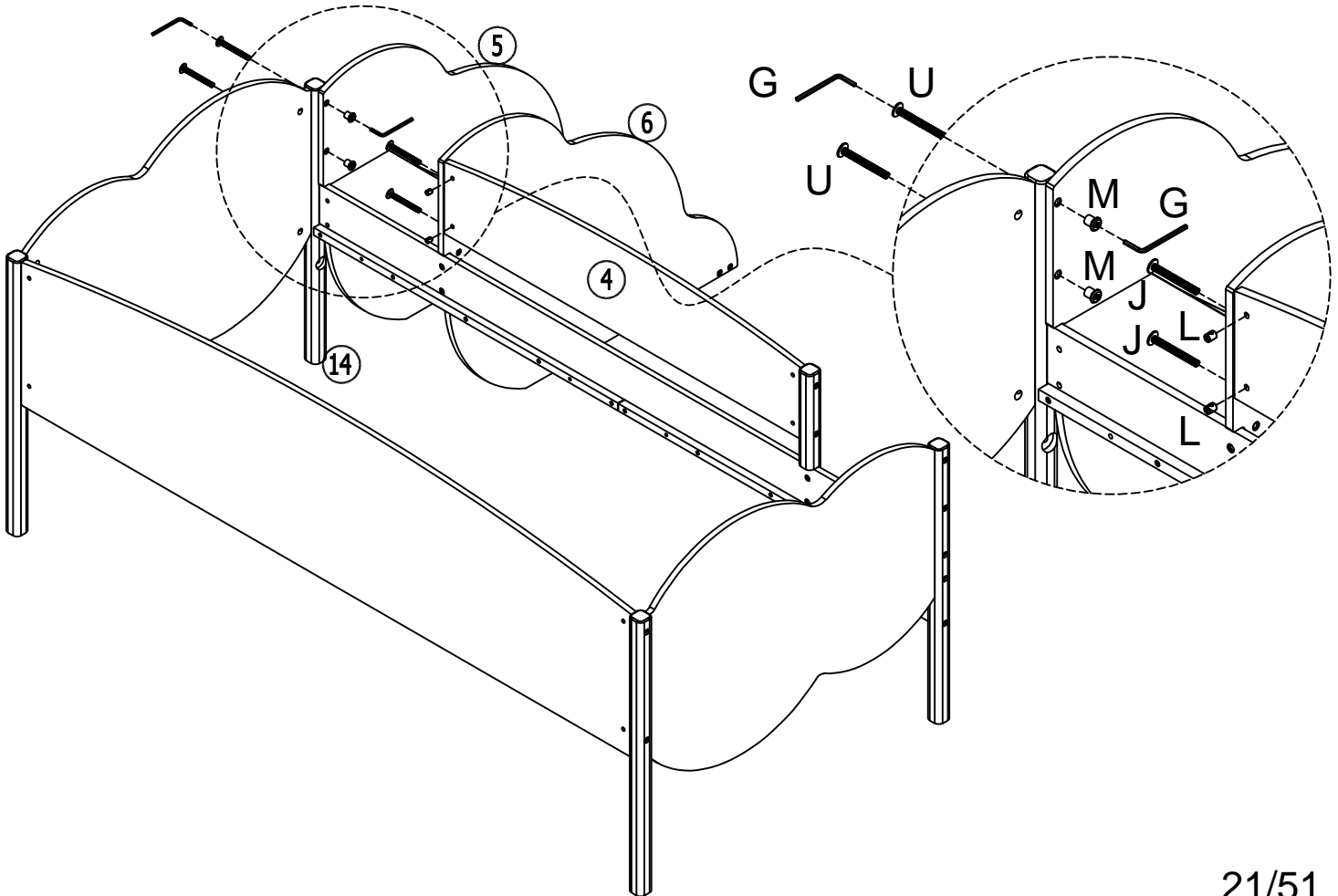

16

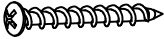
H	x 8
	
Ø4 X 30	

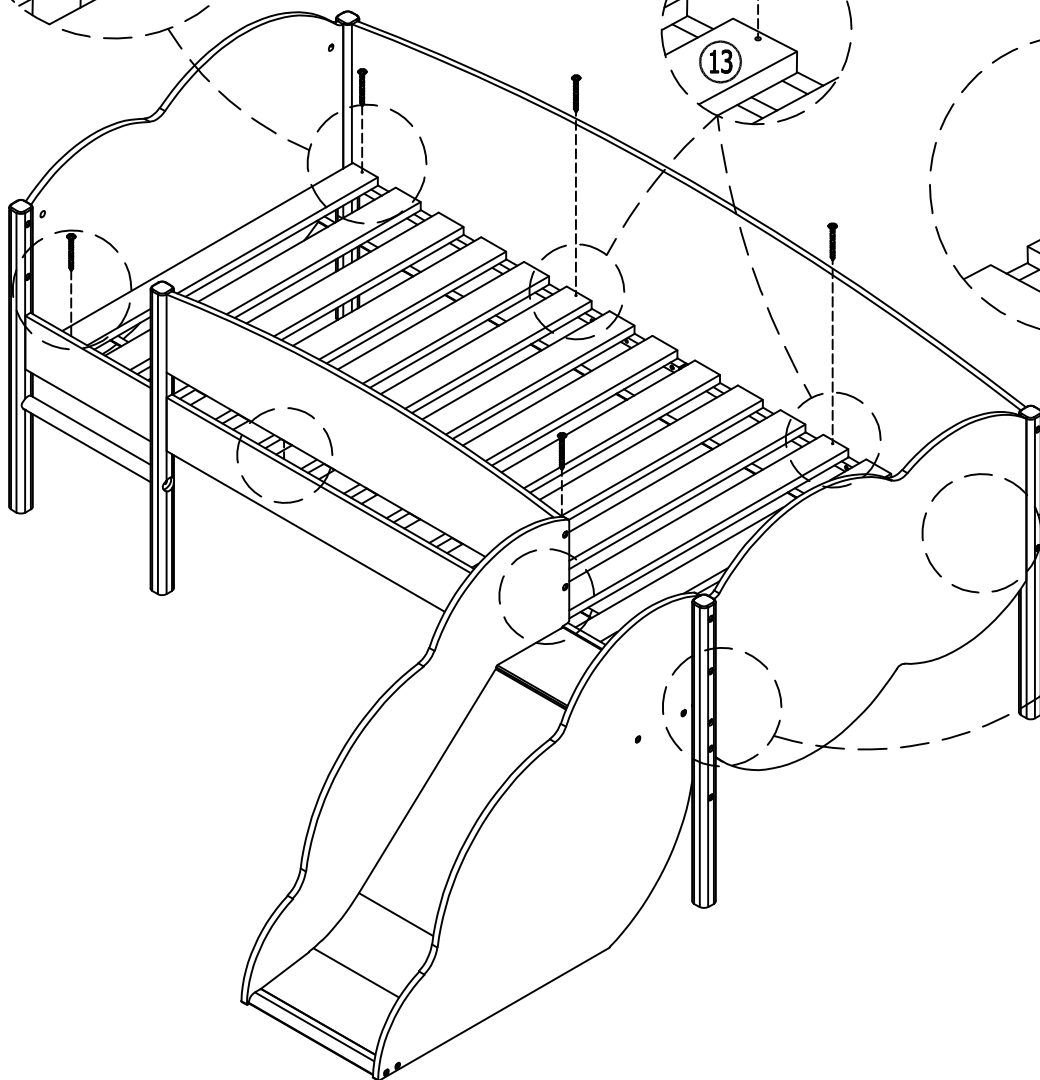
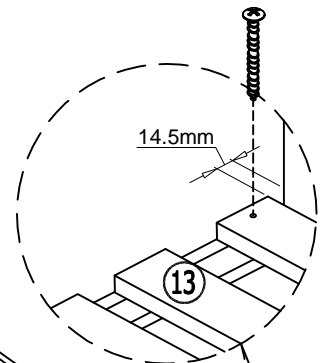
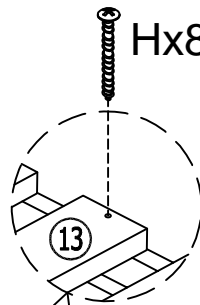
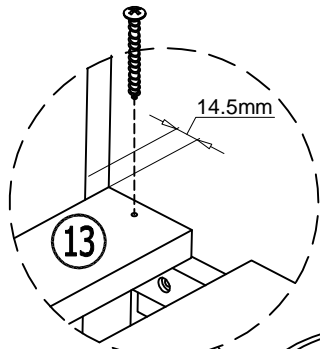
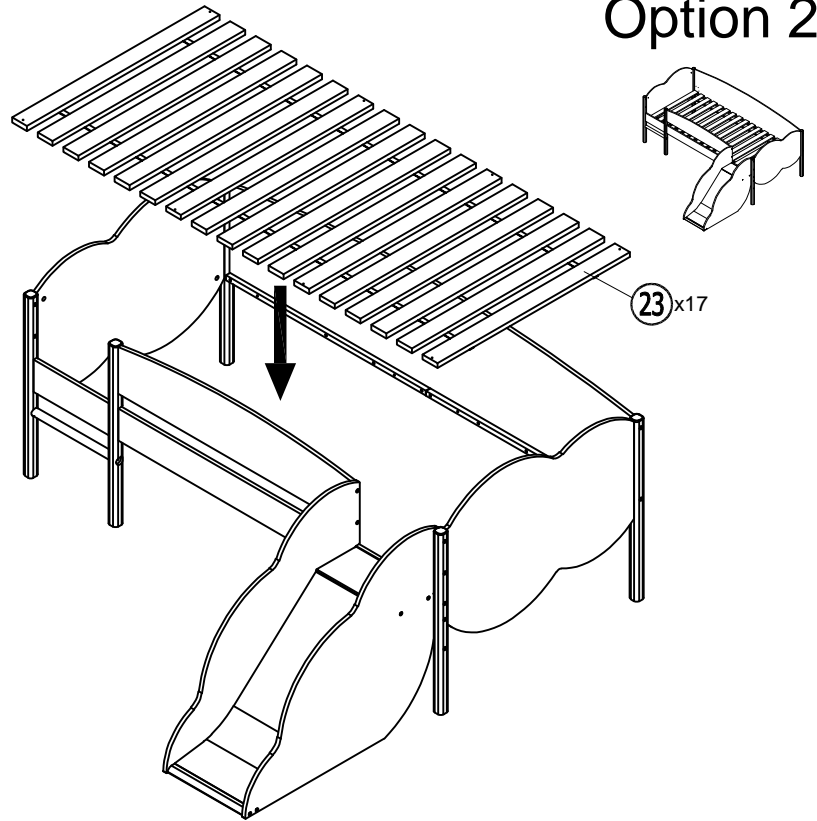

Option 2

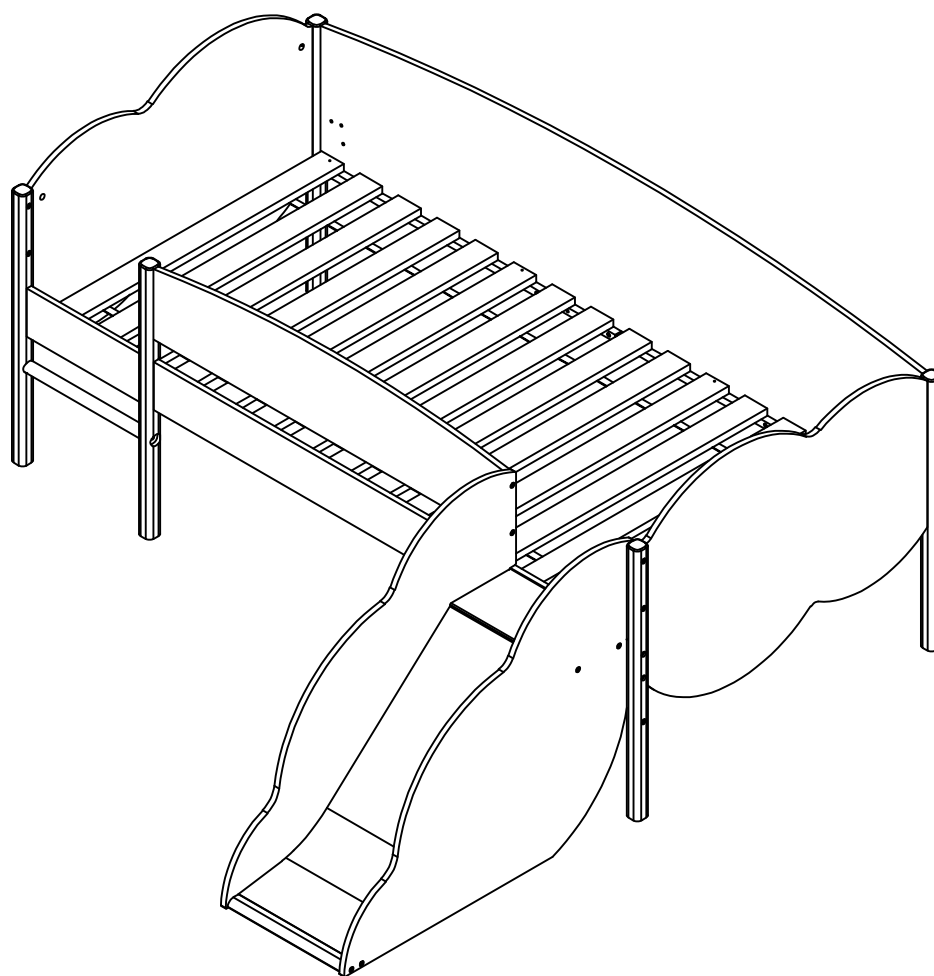

End Option 2

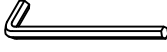

8

L	x 4	E	x 4	K	x 4	G	x 1
							
	Ø9.5 x 11		Ø8 x 30		Ø6x70		

Option 3

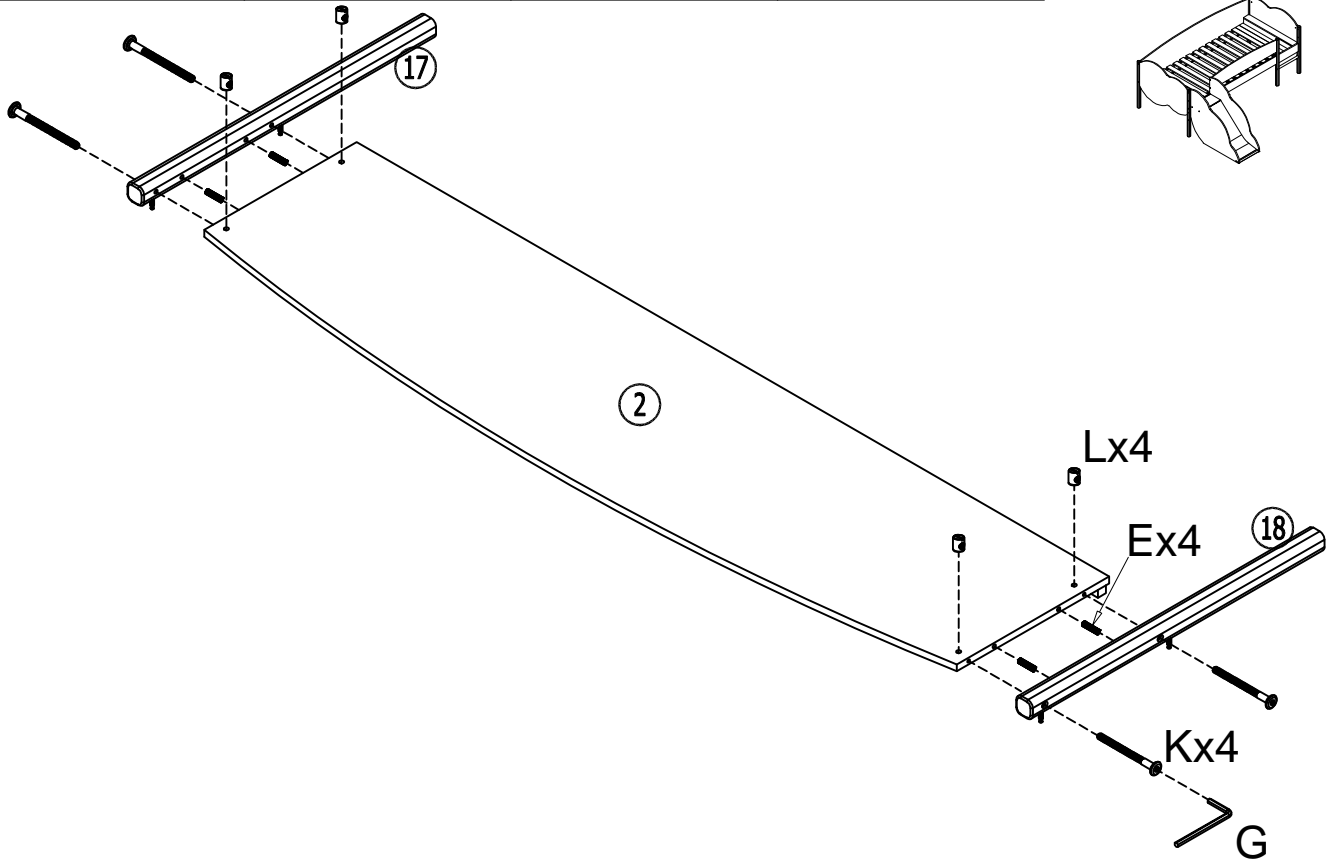
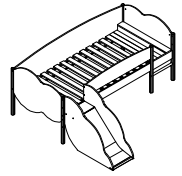

9

Q	x 1
	
	Ø6 x 70

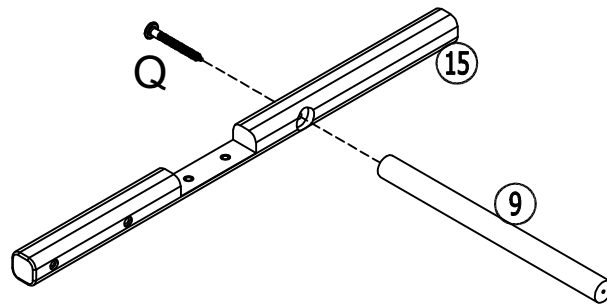





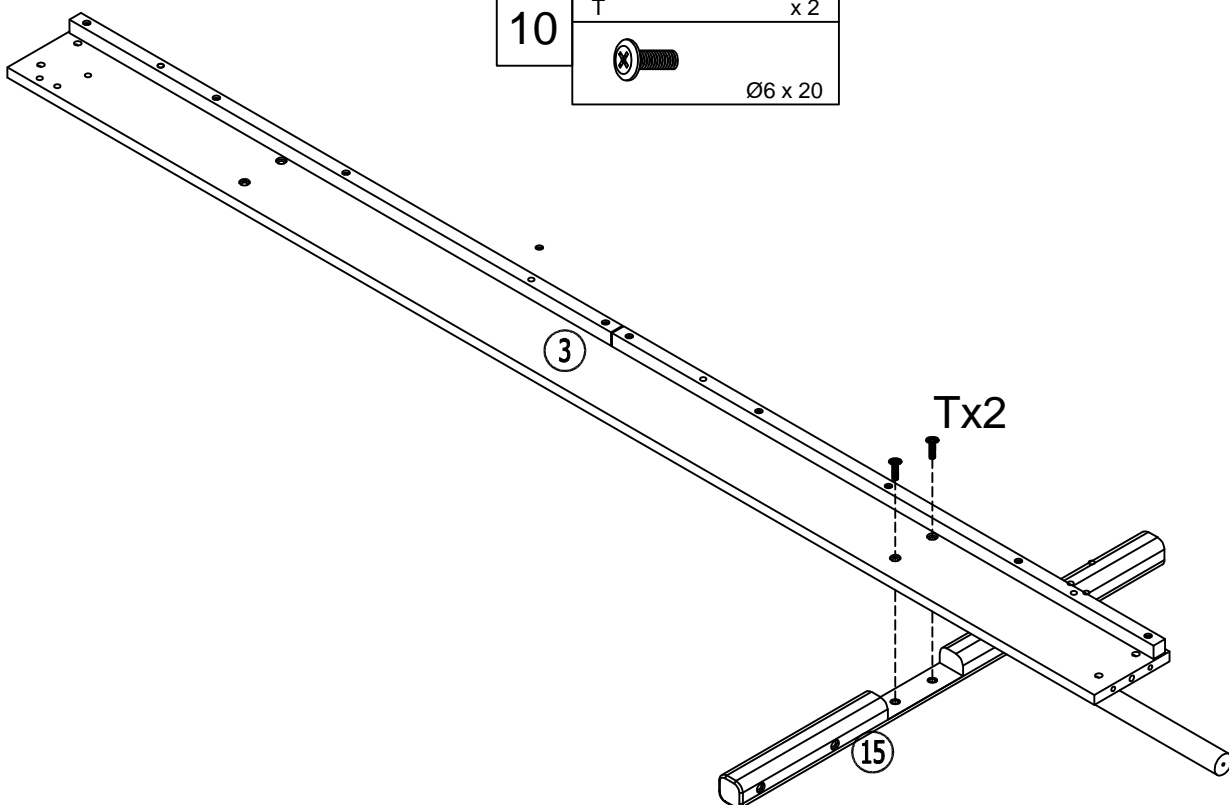

10

T	x 2
	
	Ø6 x 20

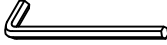

11

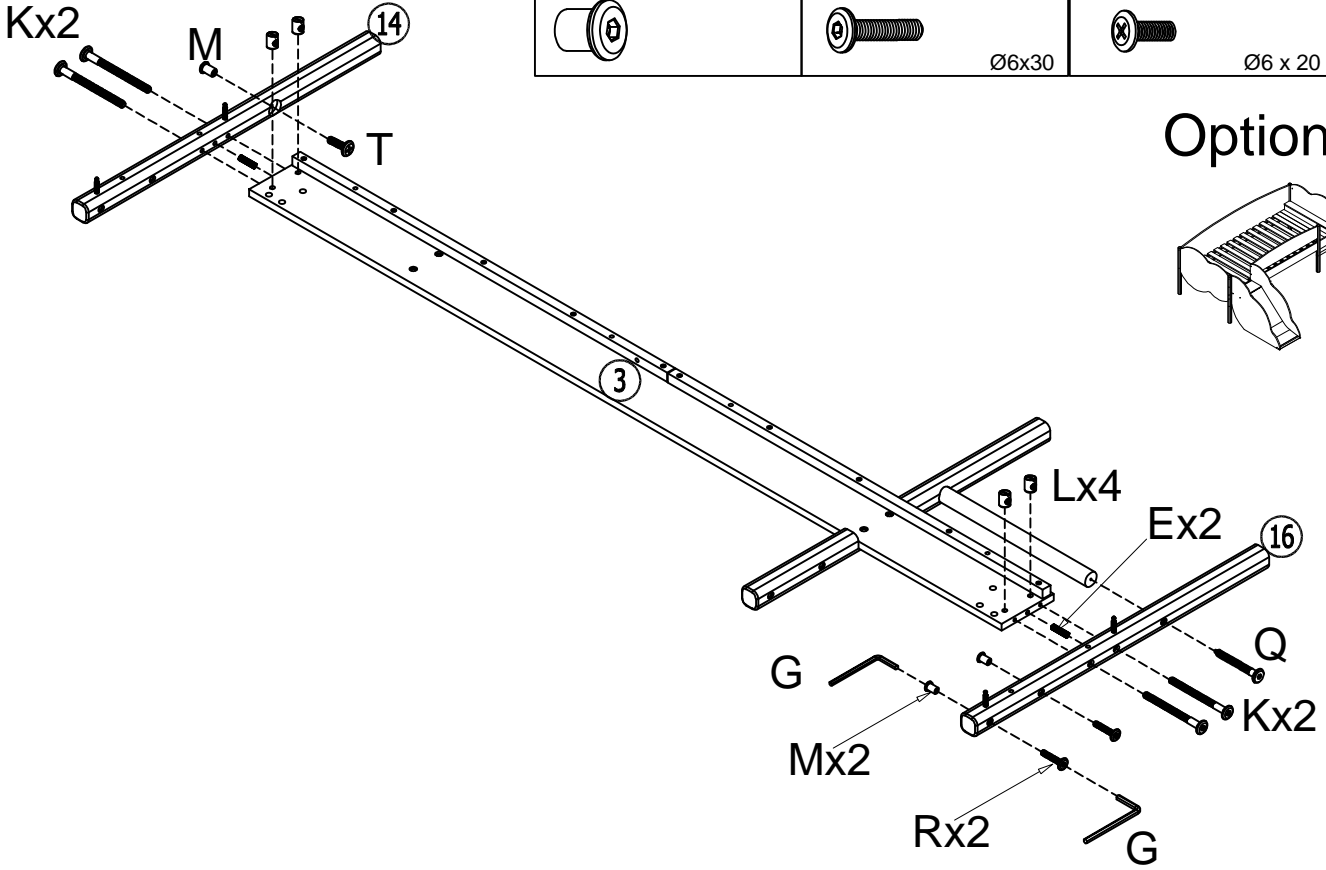

L	x 4	E	x 2	K	x 4	G	x 2	Q	x 1
									
	Ø9.5 x 11		Ø8 x 30		Ø6x70				Ø6 x 70
M	x 3	R	x 2	T	x 1				
									
			Ø6x30		Ø6 x 20				

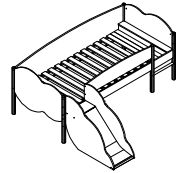

Option 3



12

B	x 4
	
	Ø14.5x11.9
E	x 4
	
	Ø8 x 30

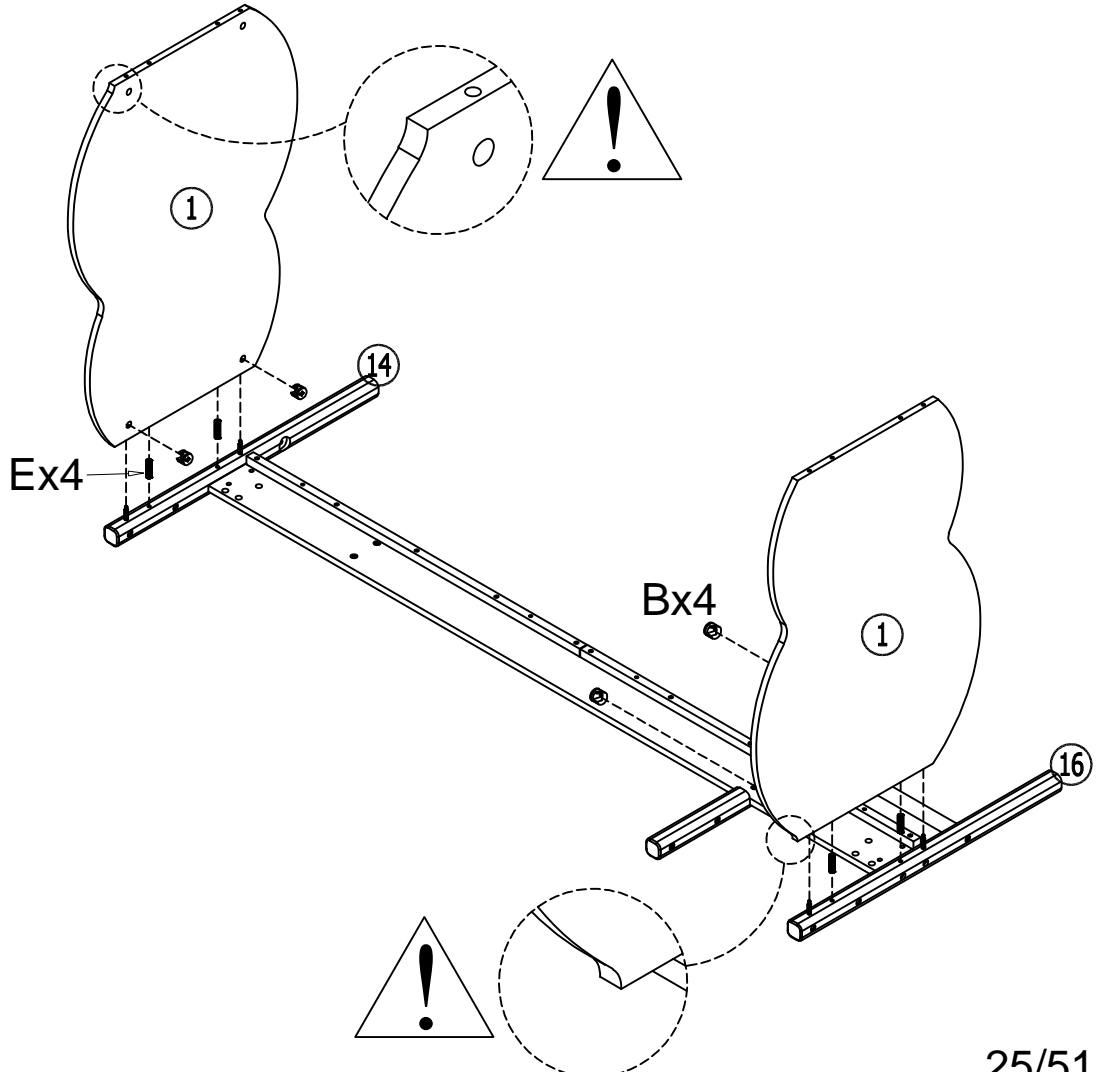
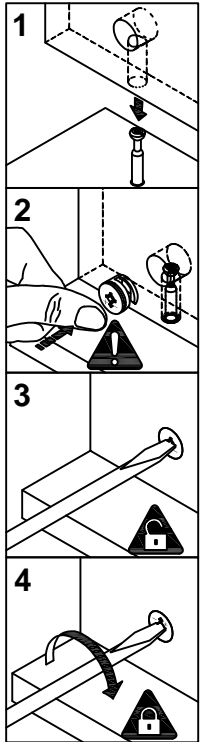

13

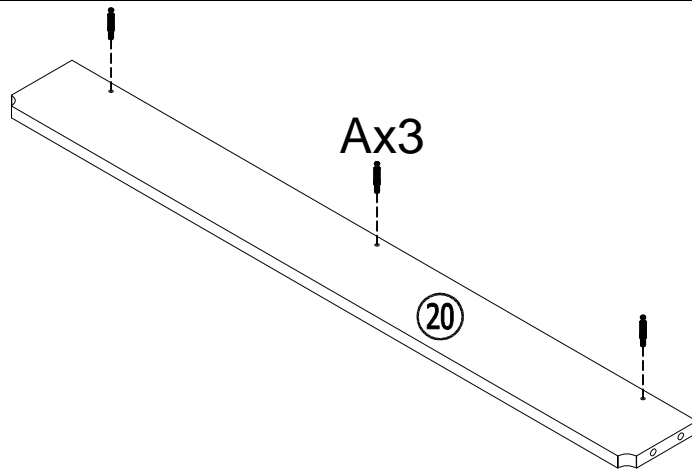
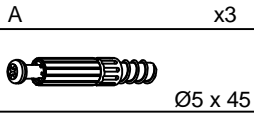

Option 3

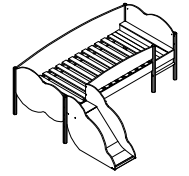

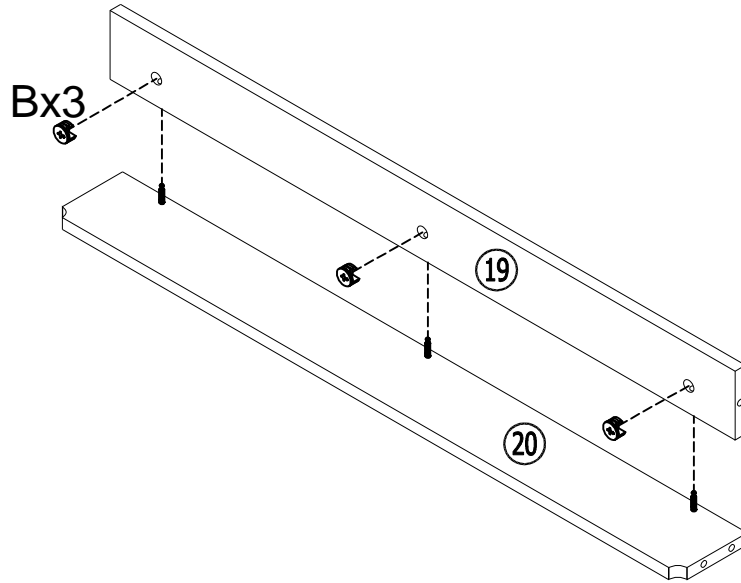
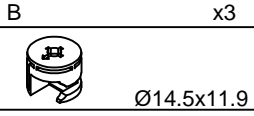

14

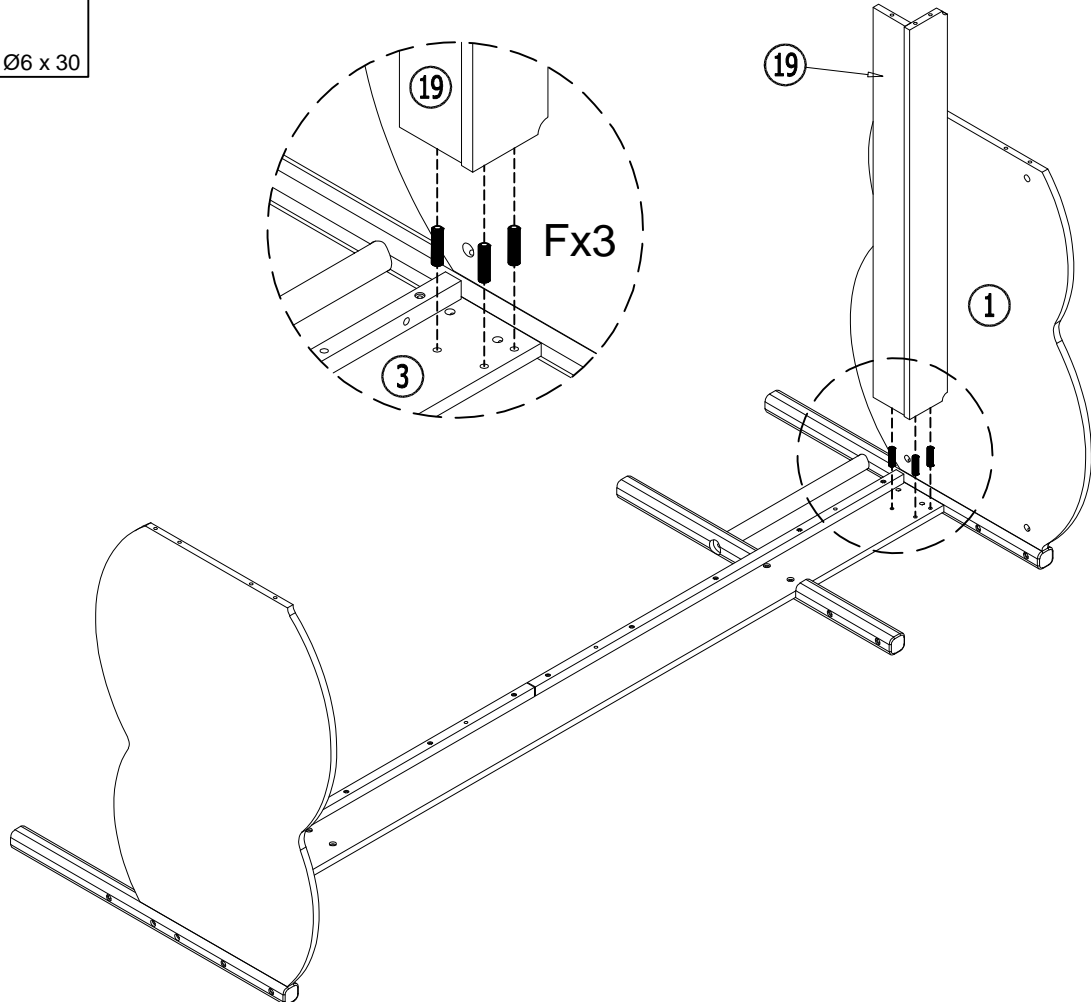
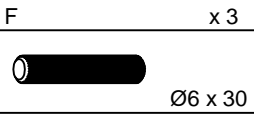

15





16

B	x4
	Ø14.5x11.9
E	x4
	Ø8 x 30
F	x3
	Ø6 x 30

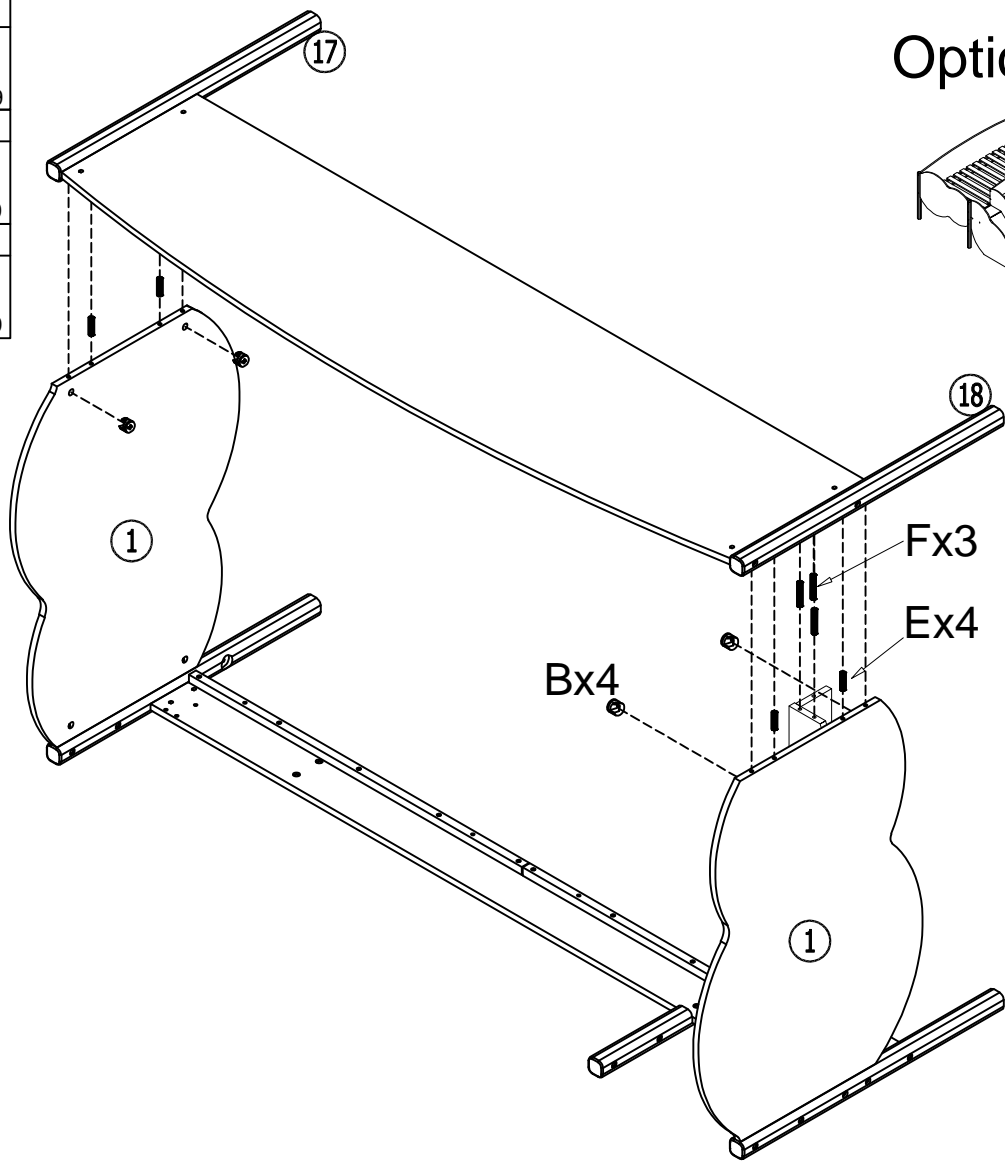
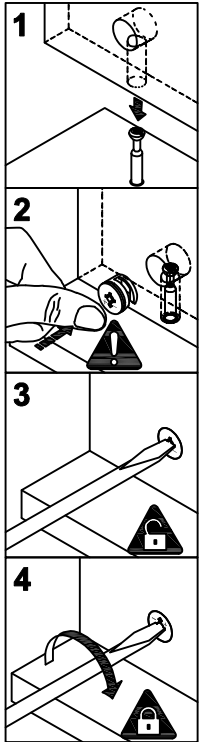
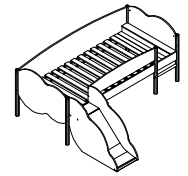
Option 3



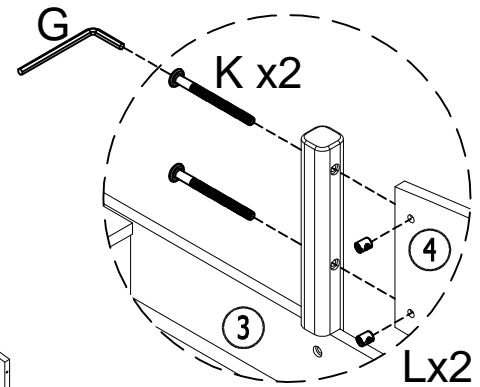
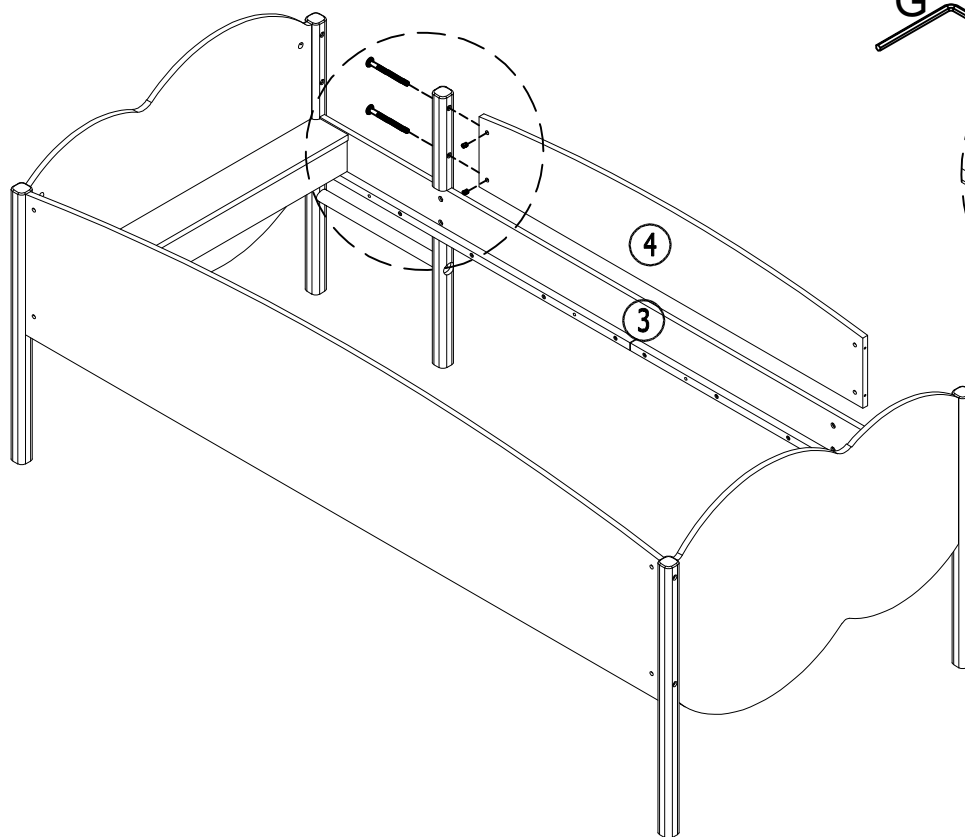

17

L	x2	K	x2	G	x1
	Ø9.5 x 11		Ø6x70		





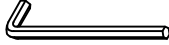

18

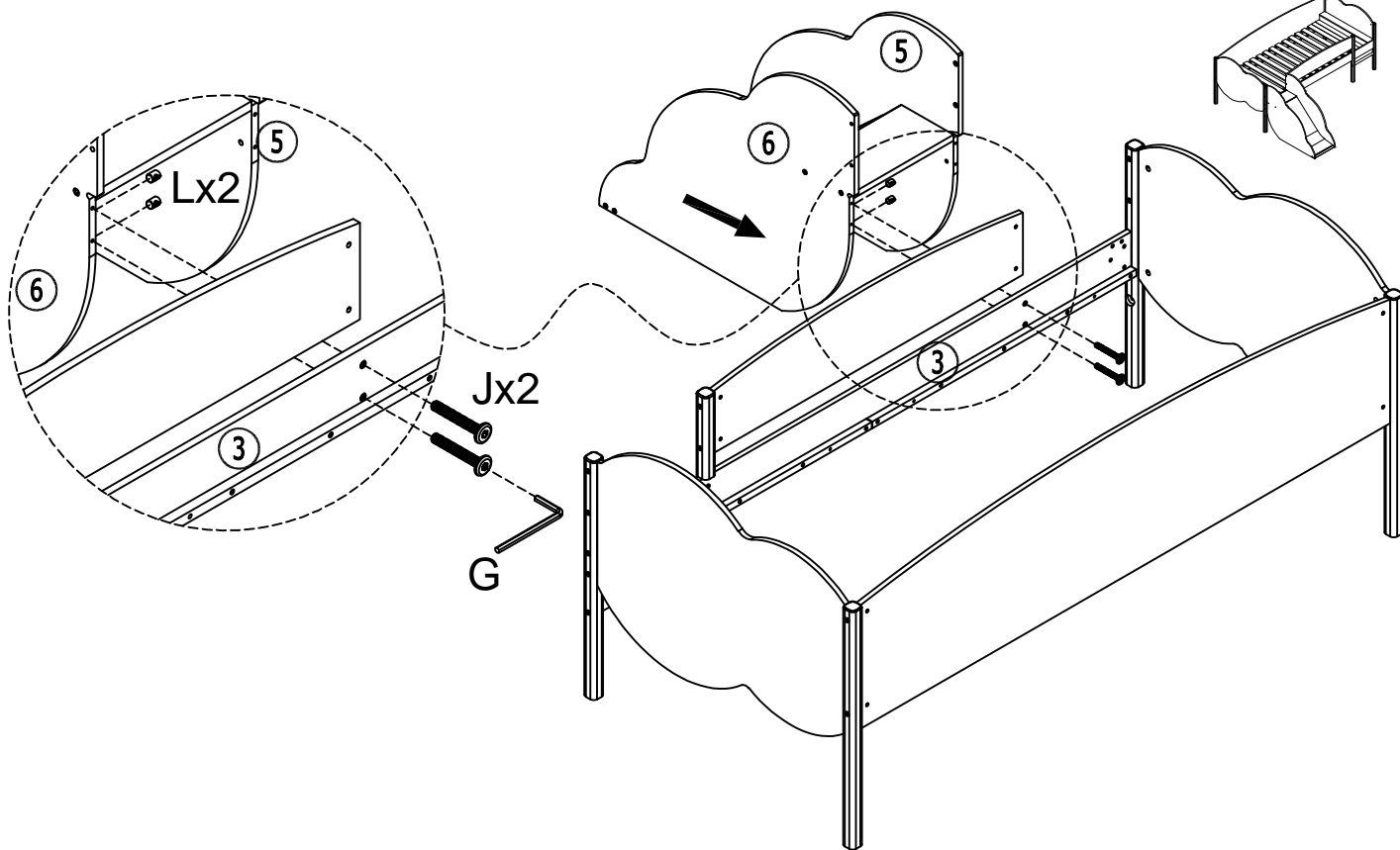
L	x2	J	x2	G	x1
					
Ø9.5 x 11		Ø6x50			

Option 3

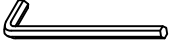

19

L	x2	J	x2	M	x2	G	x2	U	x2
									
Ø9.5 x 11		Ø6x50						Ø6x45	

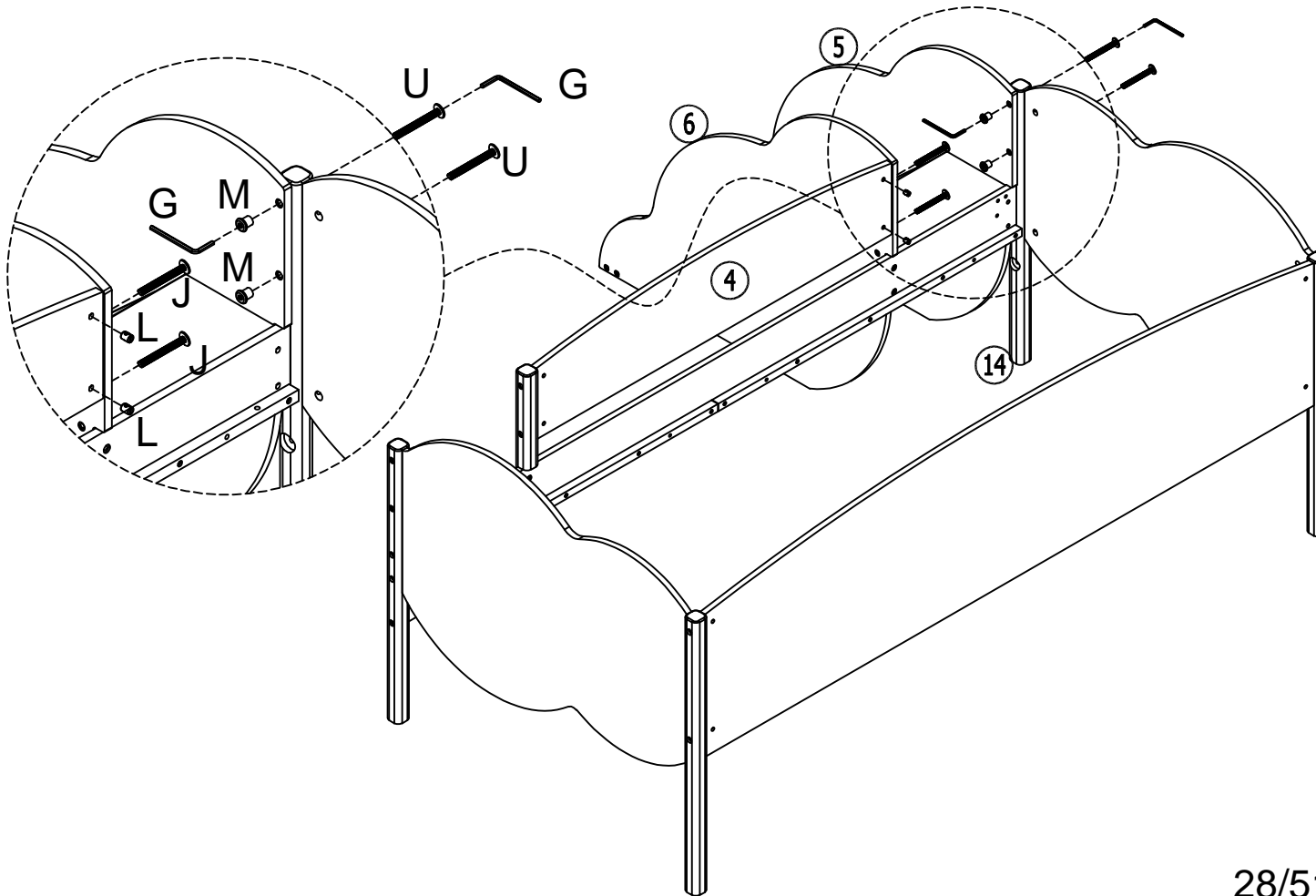

20

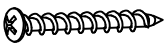
H	x 8
	
Ø4 X 30	



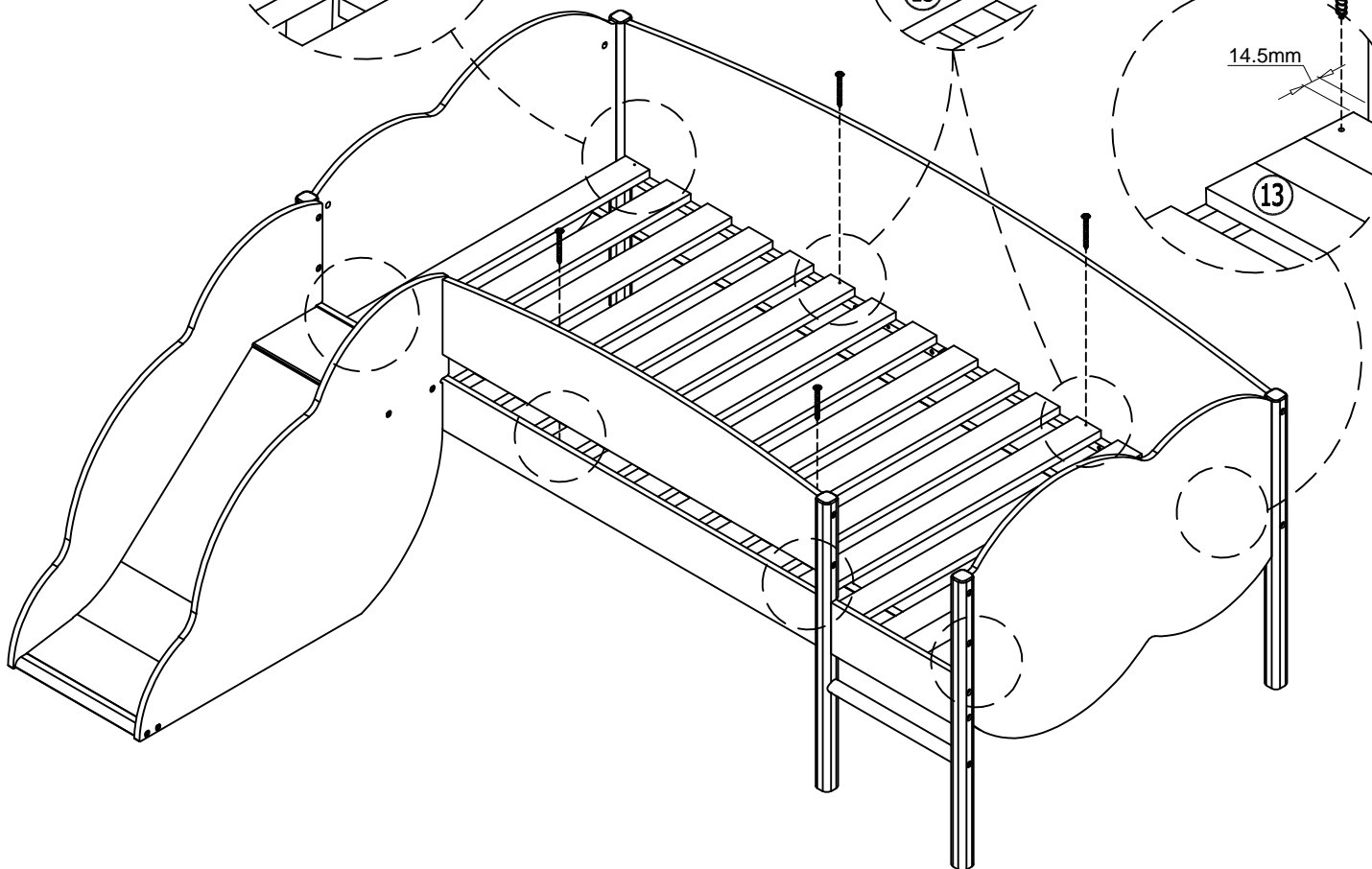
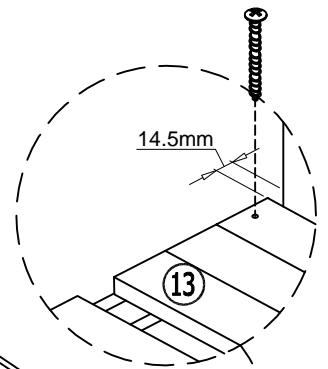
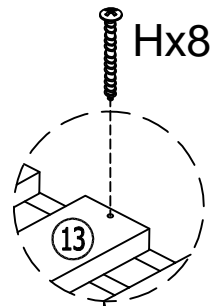
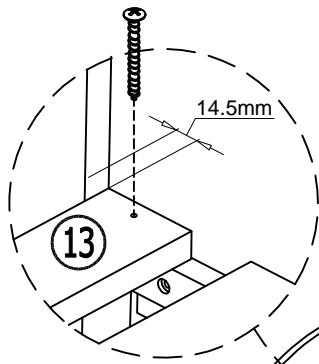
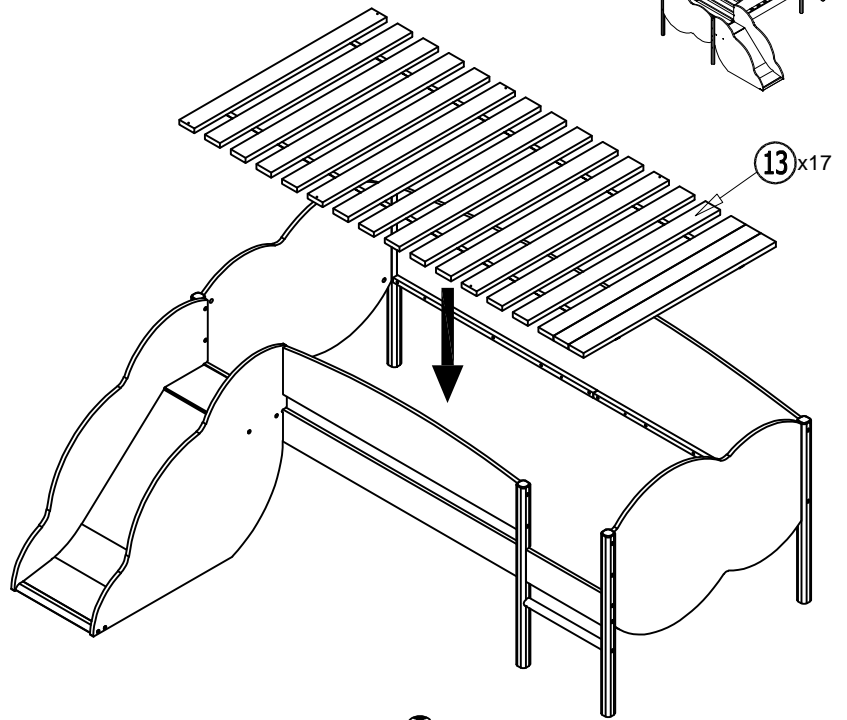
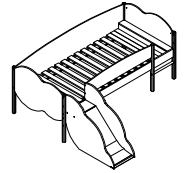

Option 3

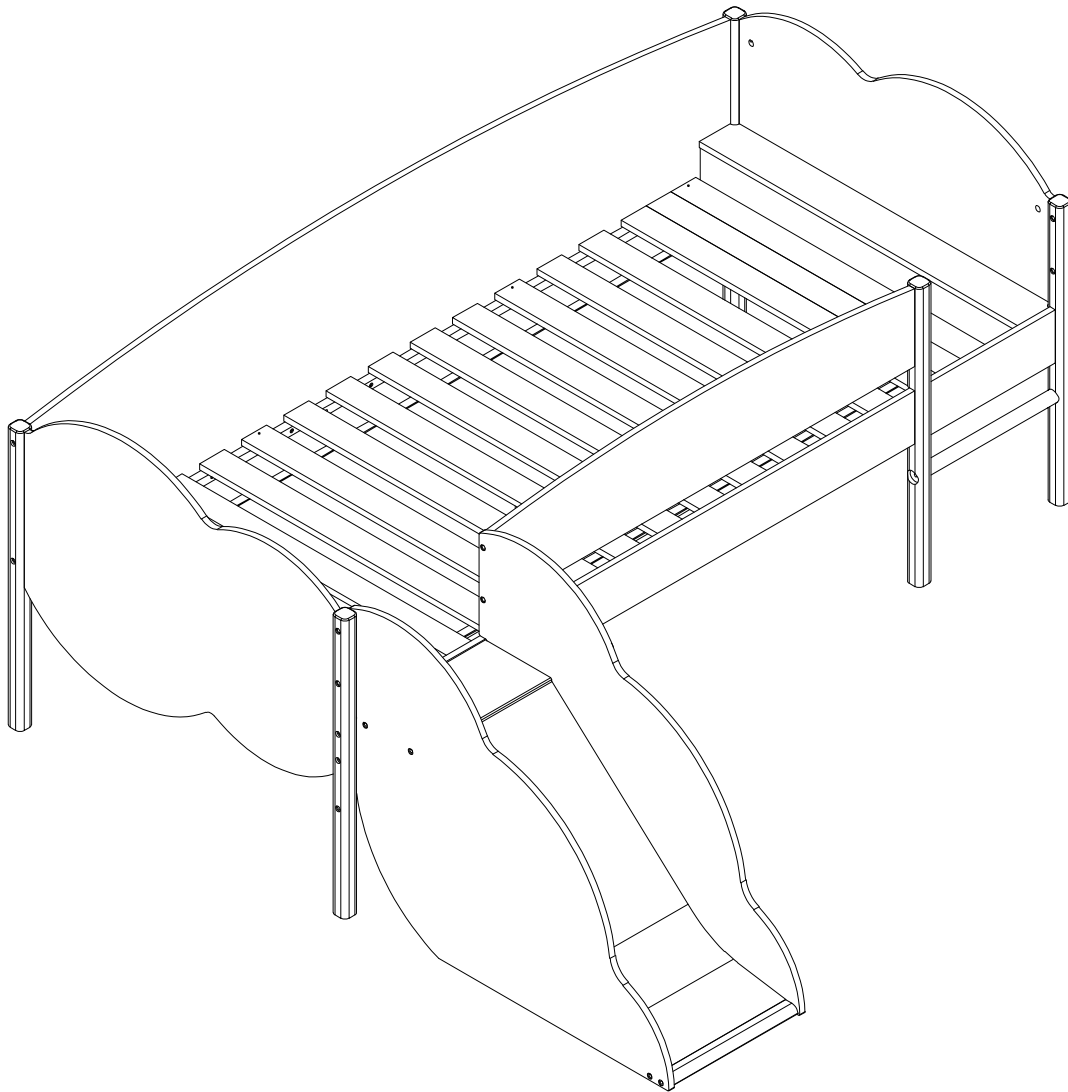

End Option 3



8

L	x 4	E	x 4	K	x 4	G	x 1
							
Ø9.5 x 11		Ø8 x 30		Ø6x70			

Option 4

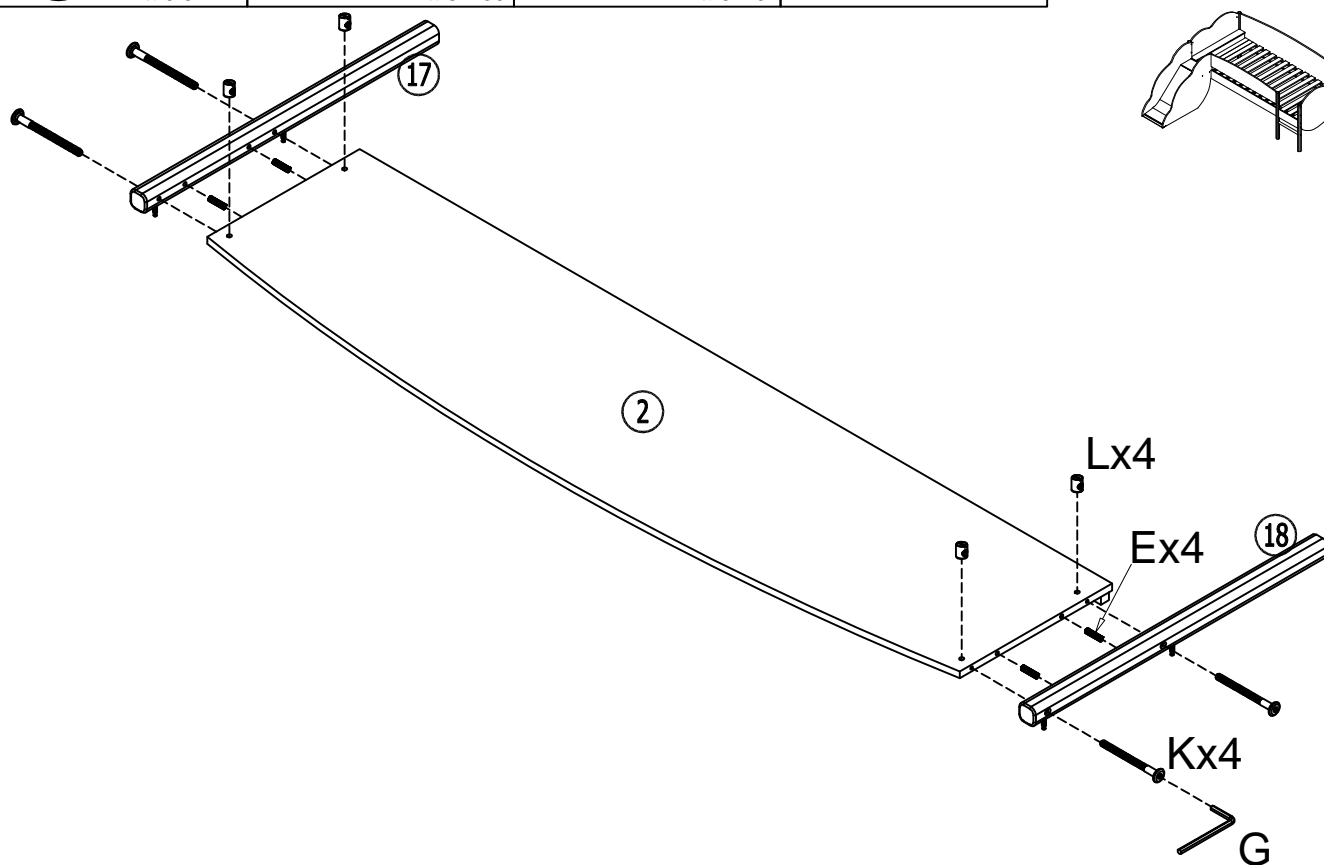
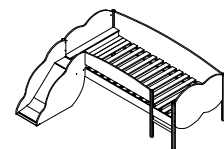

9

Q	x 1
	
Ø6 x 70	

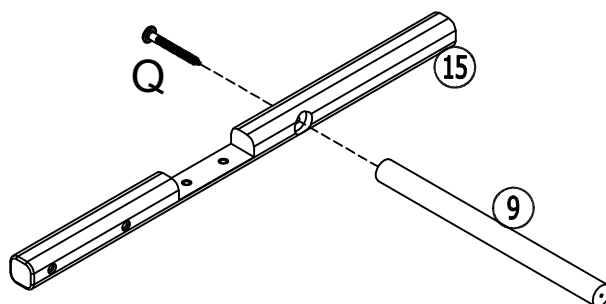





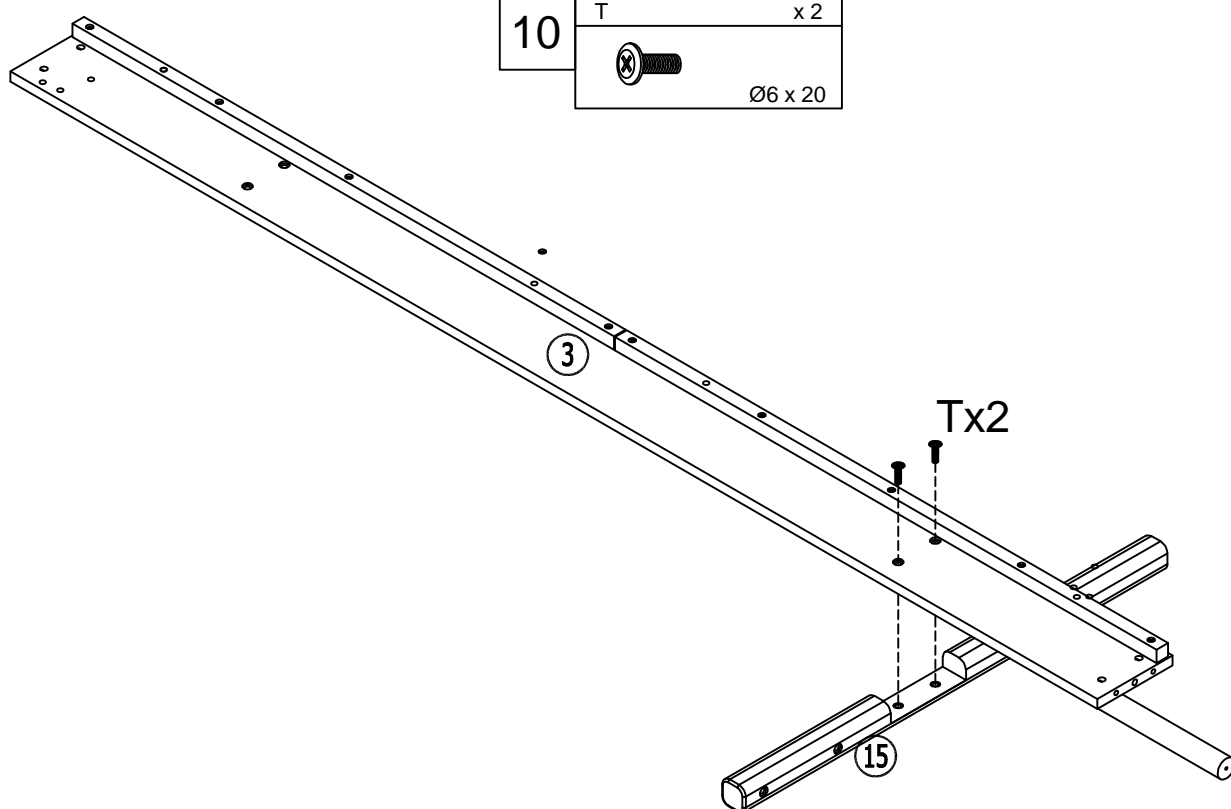

10

T	x 2
	
Ø6 x 20	

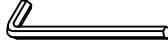

11

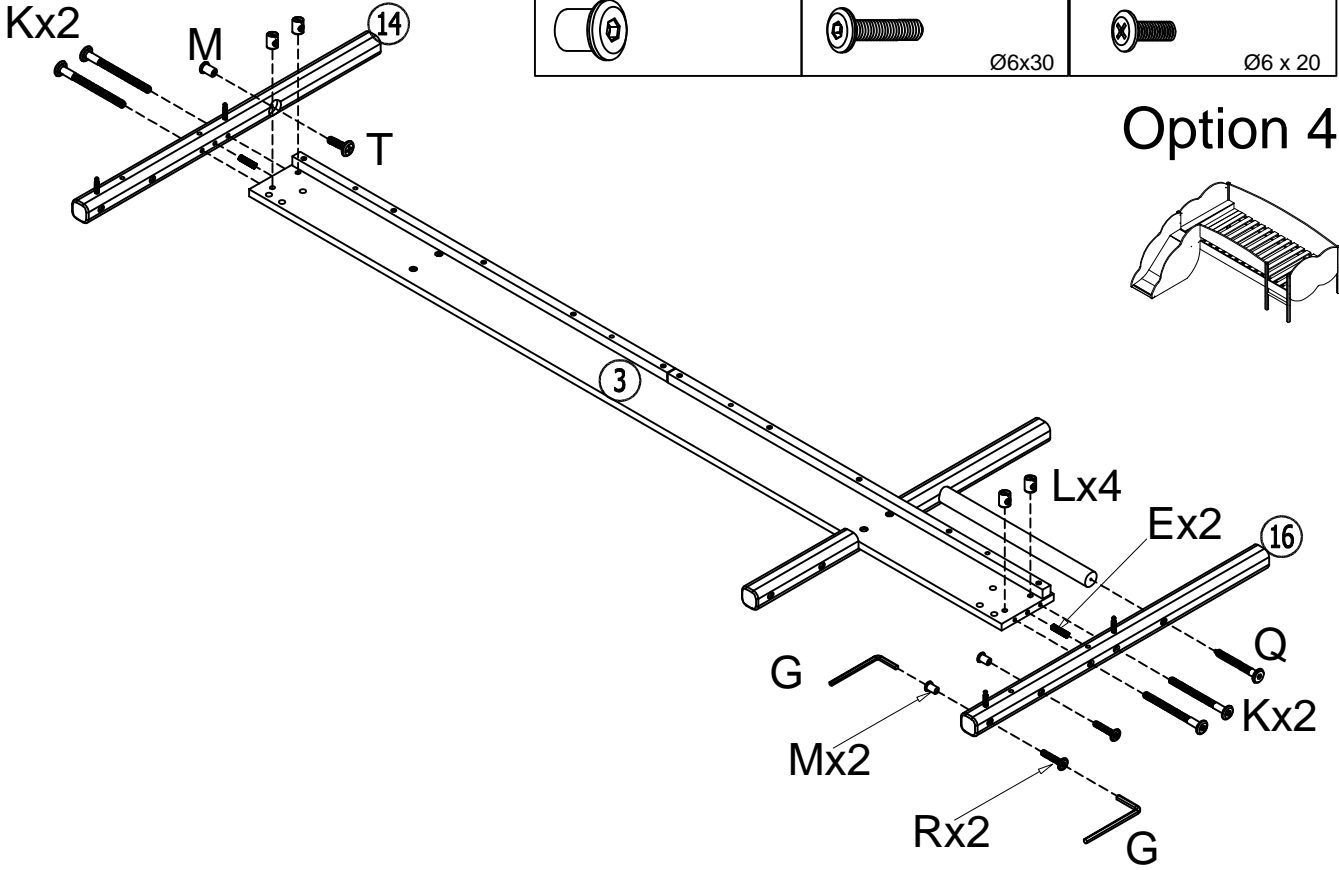

L	x 4	E	x 2	K	x 4	G	x 2	Q	x 1
									
	Ø9.5 x 11		Ø8 x 30		Ø6x70				Ø6 x 70
M	x 3	R	x 2	T	x 1				
									
			Ø6x30		Ø6 x 20				

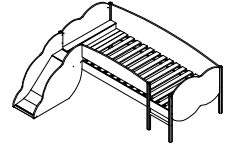

Option 4



12

B	x 4
	
	Ø14.5x11.9
E	x 4
	
	Ø8 x 30

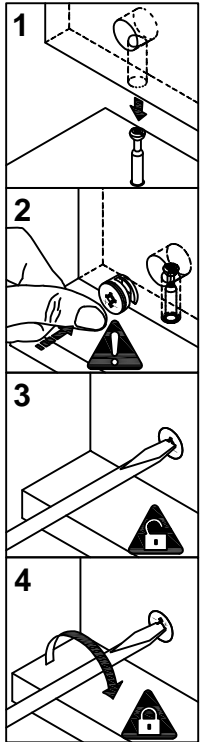
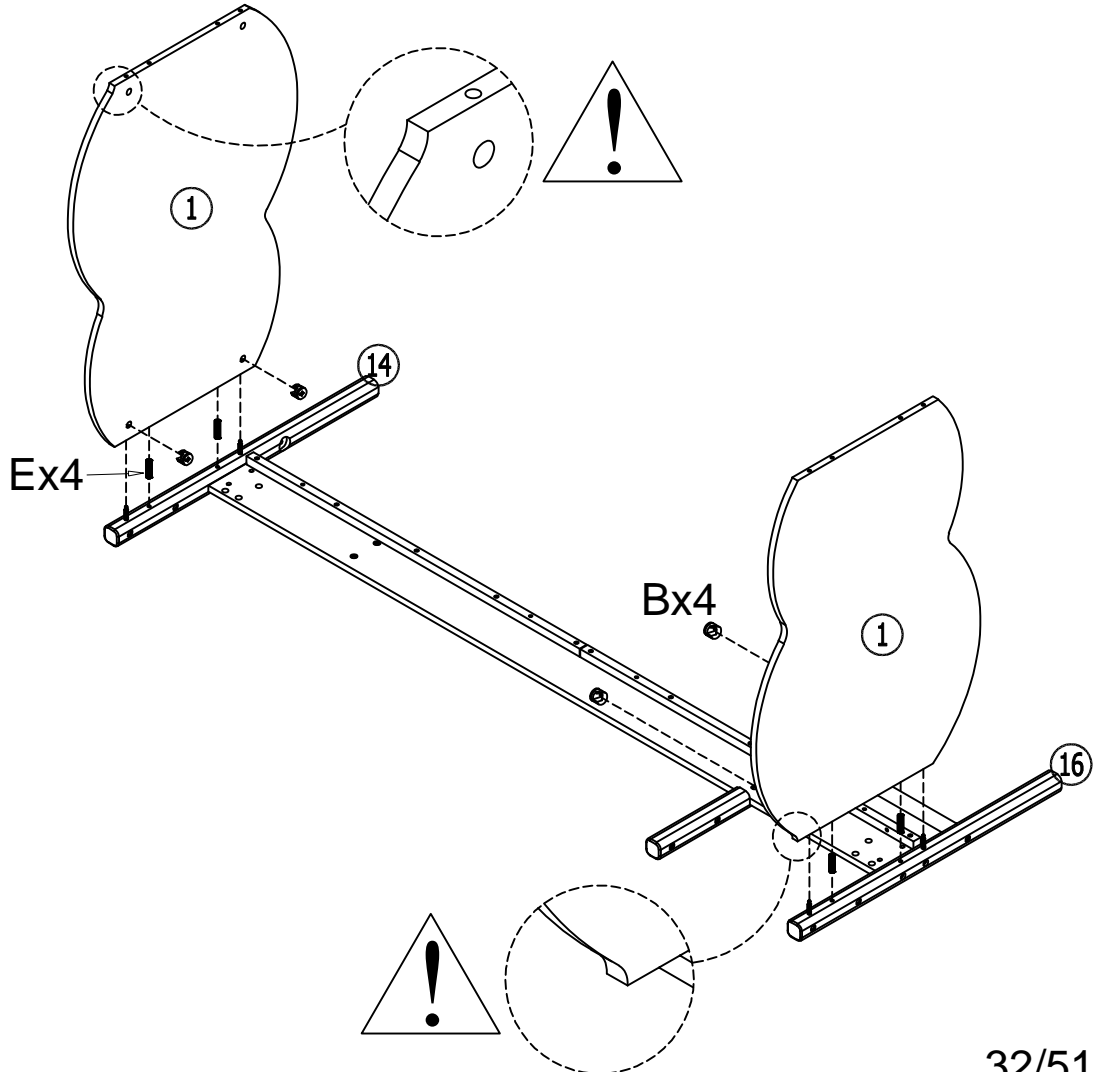

13

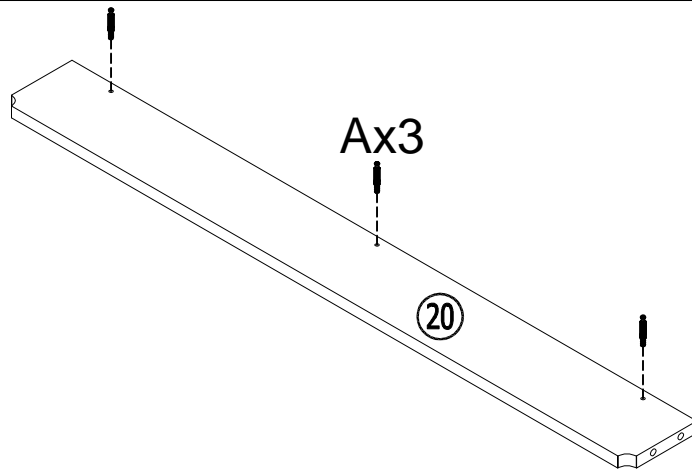
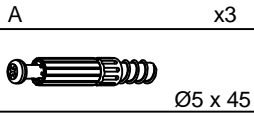

Option 4

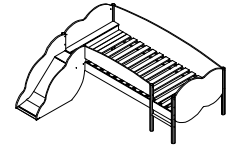

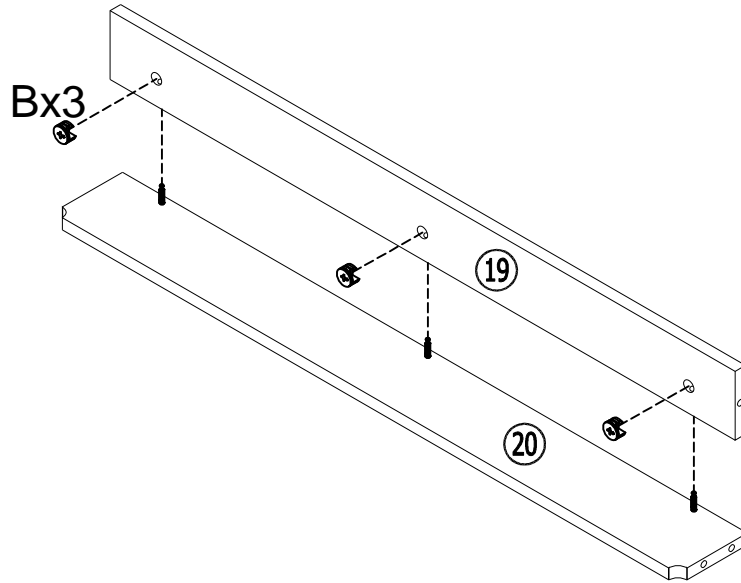
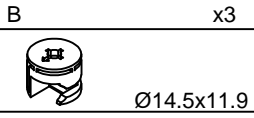

14

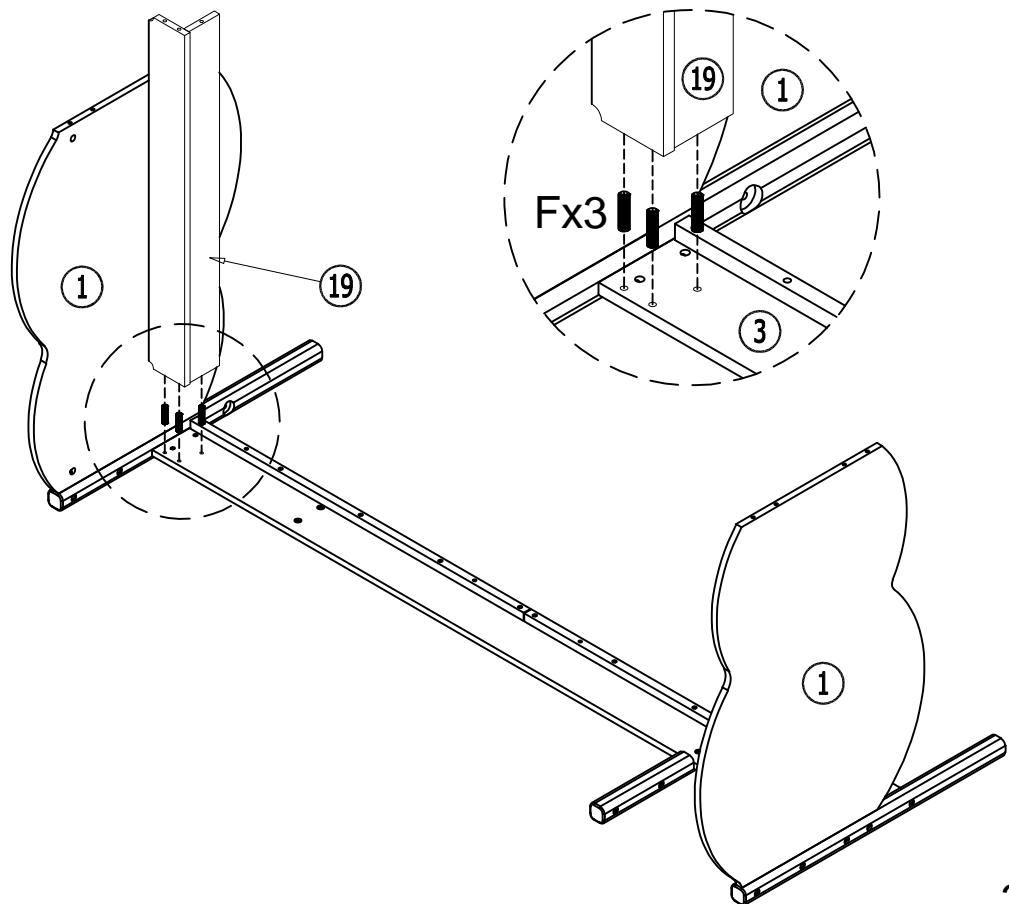
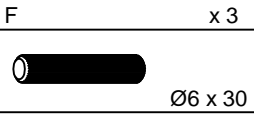

15





16

B	x4
	Ø14.5x11.9
E	x4
	Ø8 x 30
F	x3
	Ø6 x 30

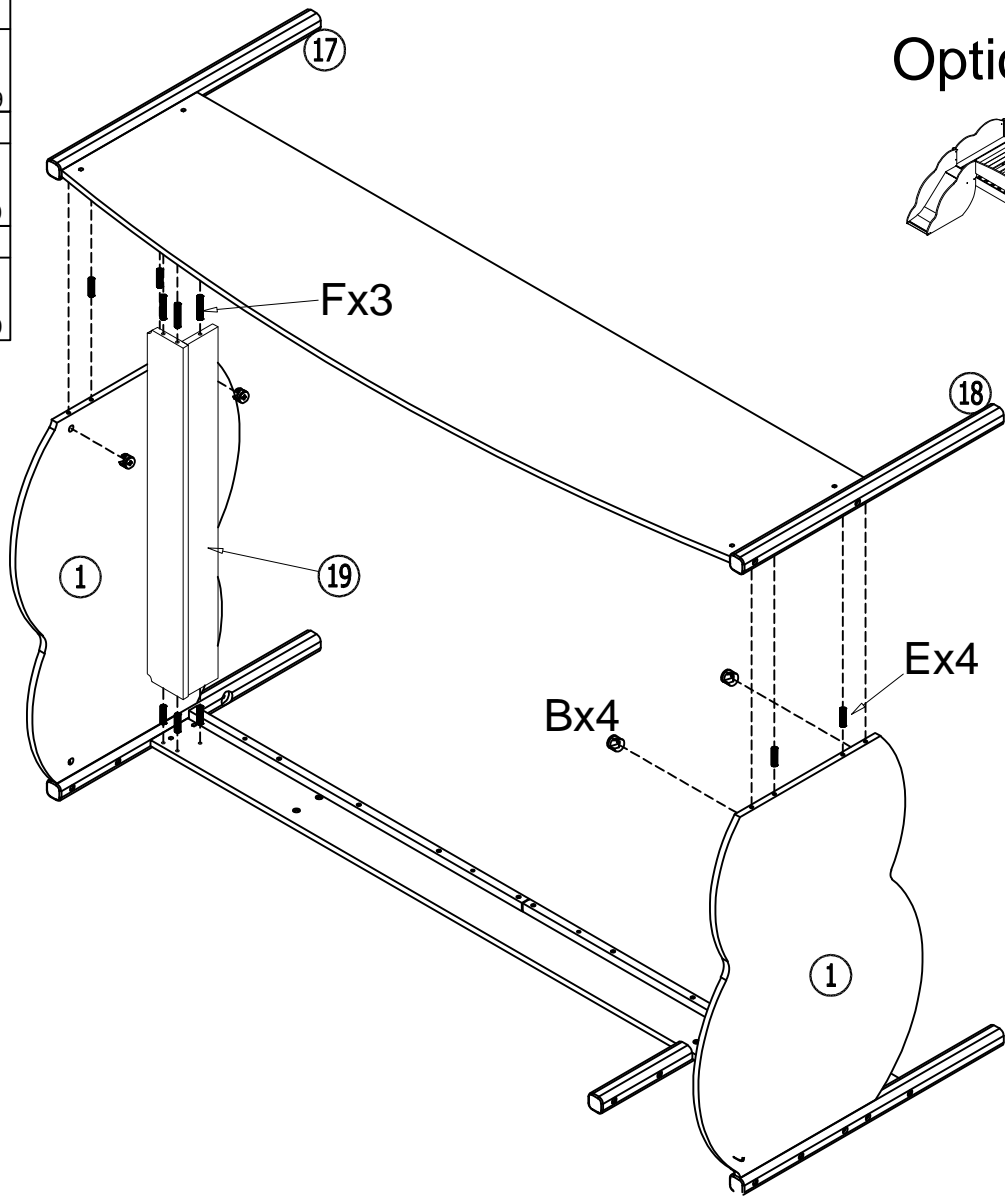
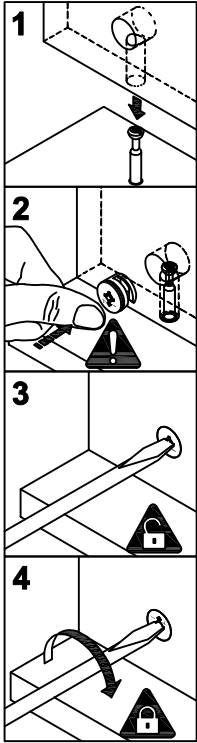
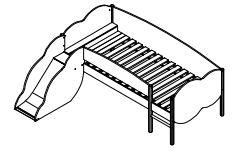
Option 4



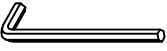

17

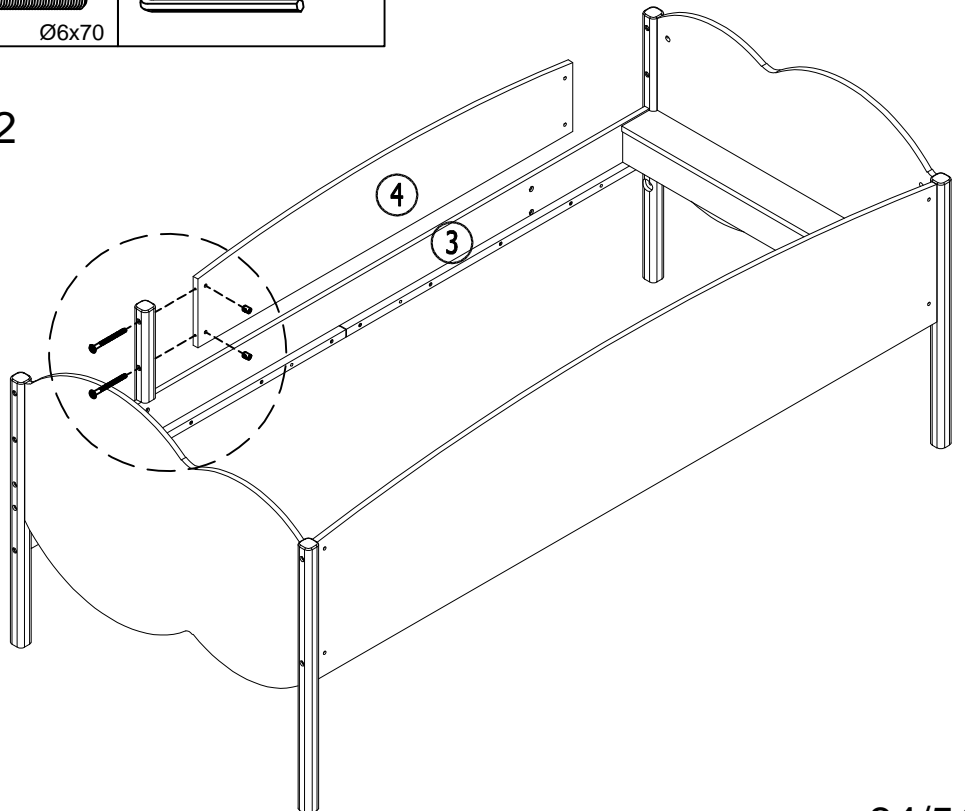
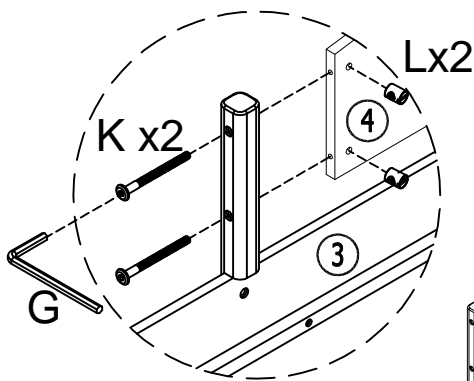
L	x2	K	x2	G	x1
	Ø9.5 x 11		Ø6x70		





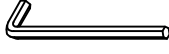

18

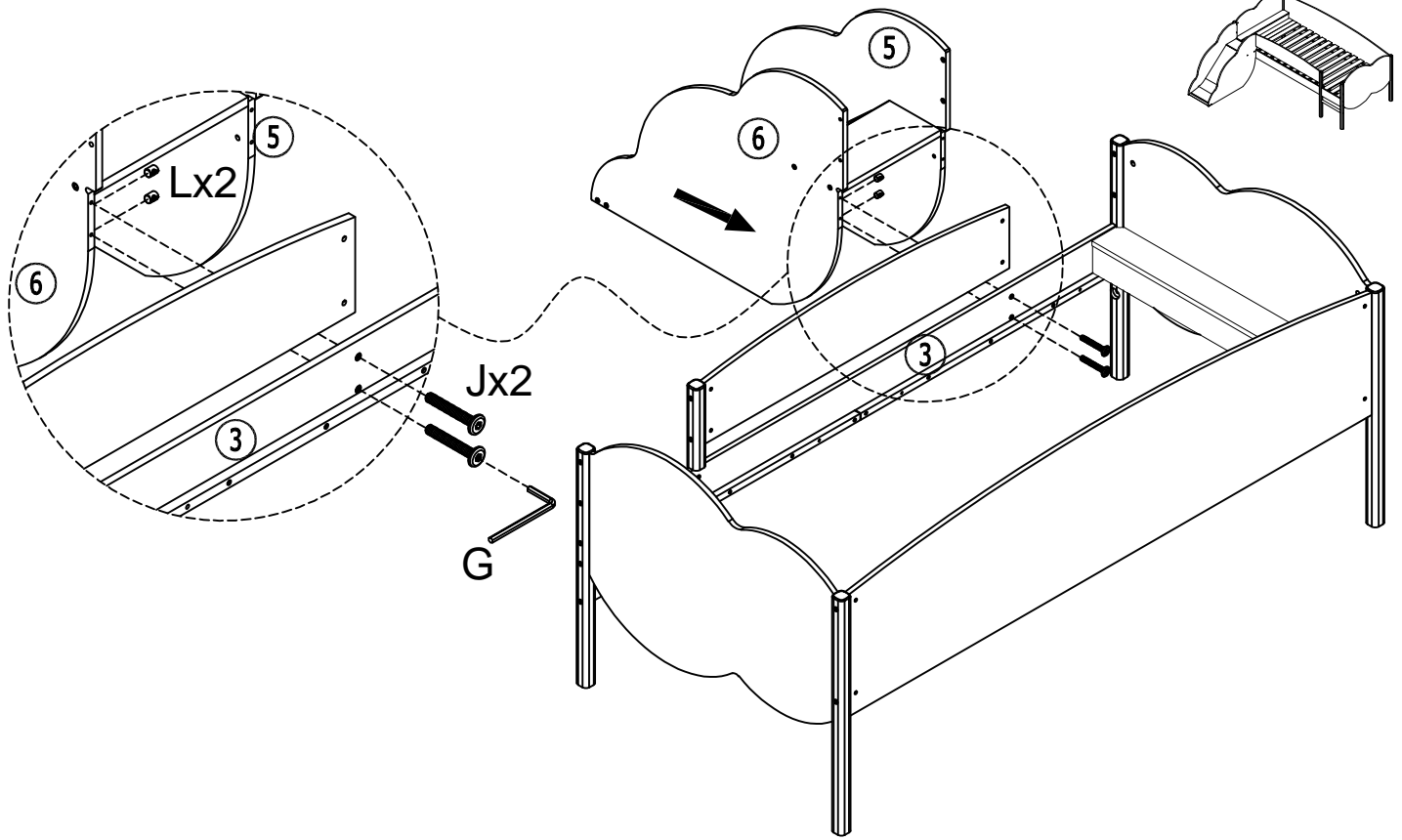
L	x2	J	x2	G	x1
					
Ø9.5 x 11		Ø6x50			

Option 4

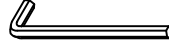

19

L	x2	J	x2	M	x2	G	x2	U	x2
									
Ø9.5 x 11		Ø6x50						Ø6x45	

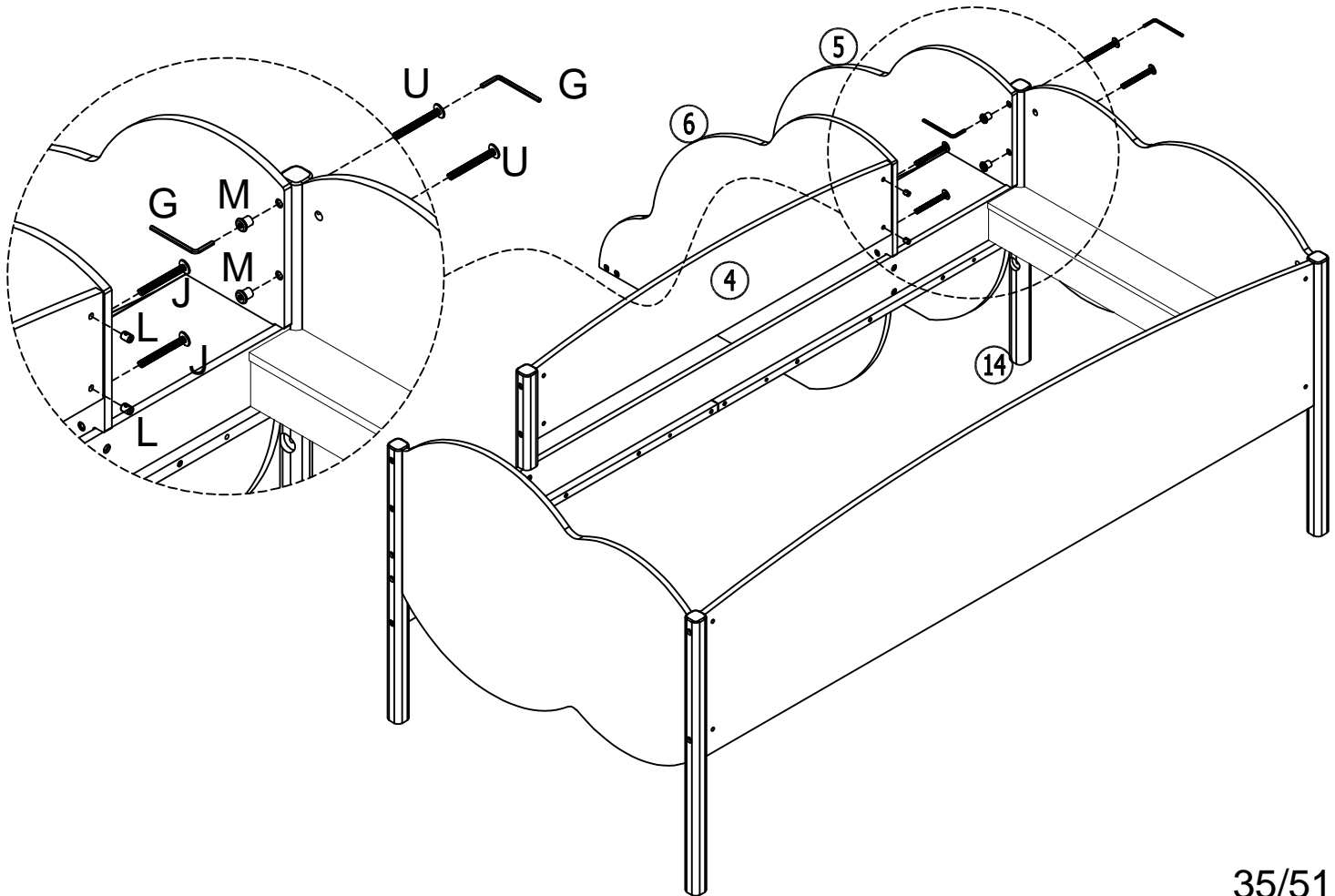

20

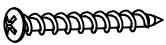
H	x 8
	
Ø4 X 30	



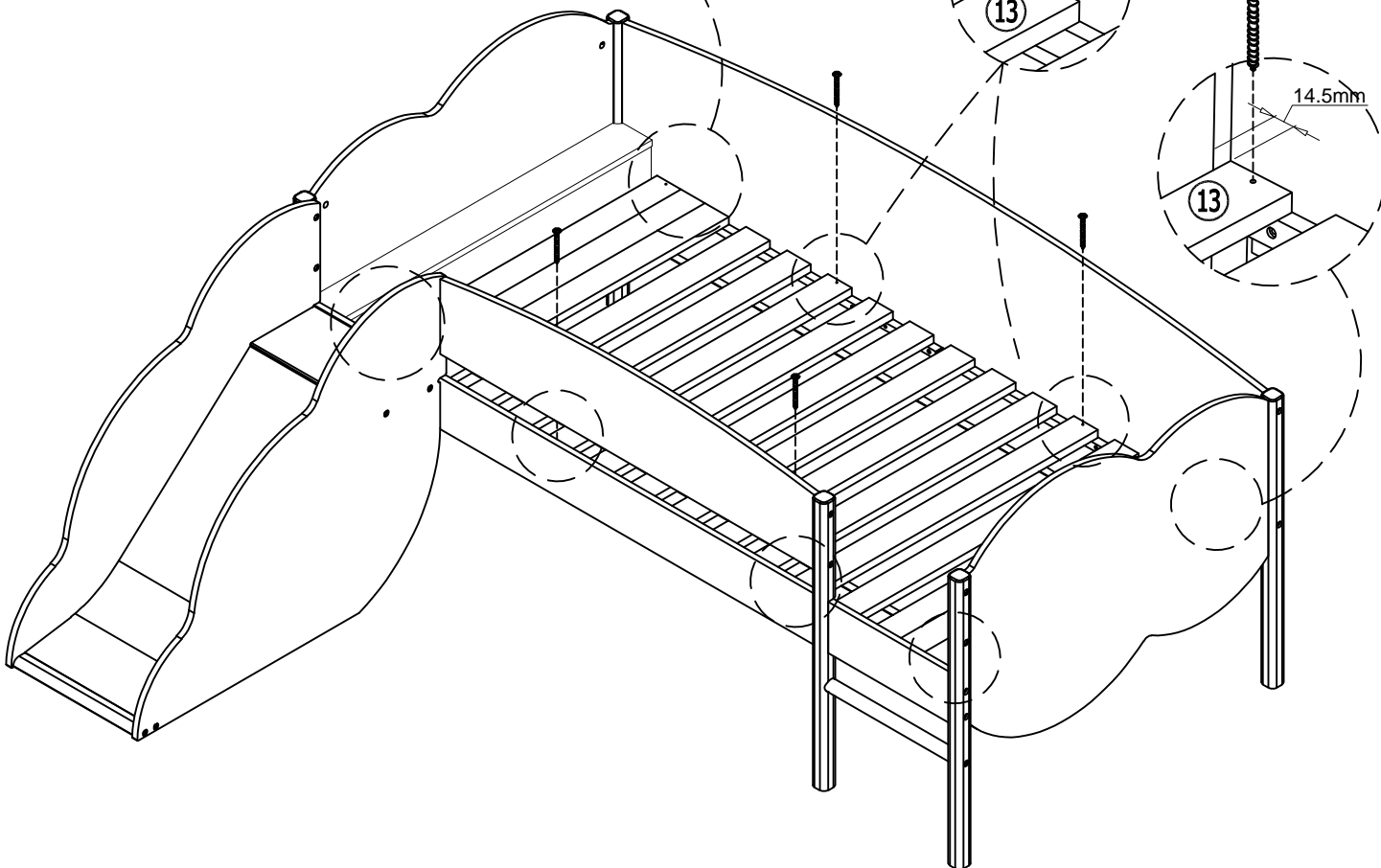
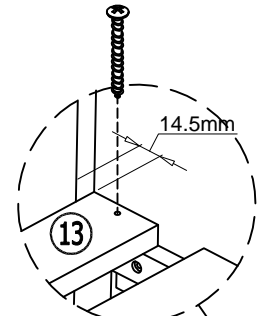
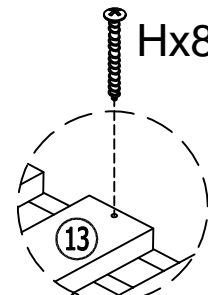
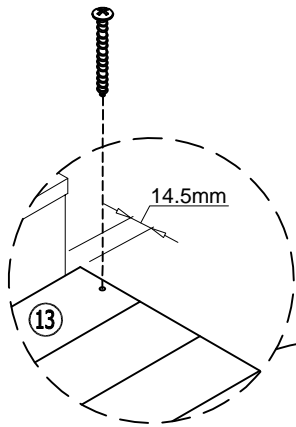
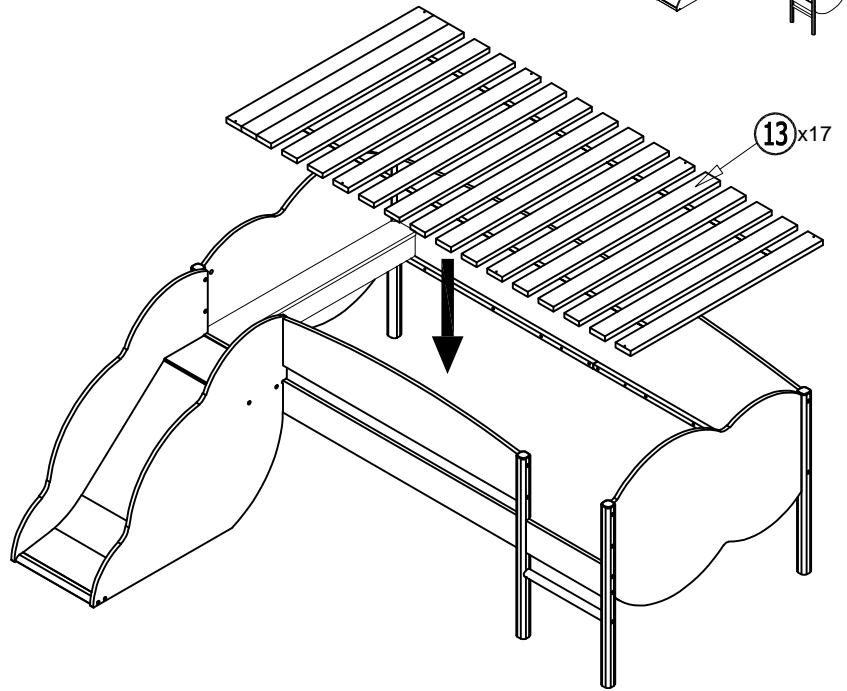
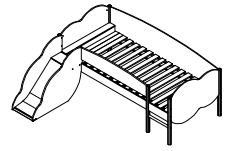

Option 4

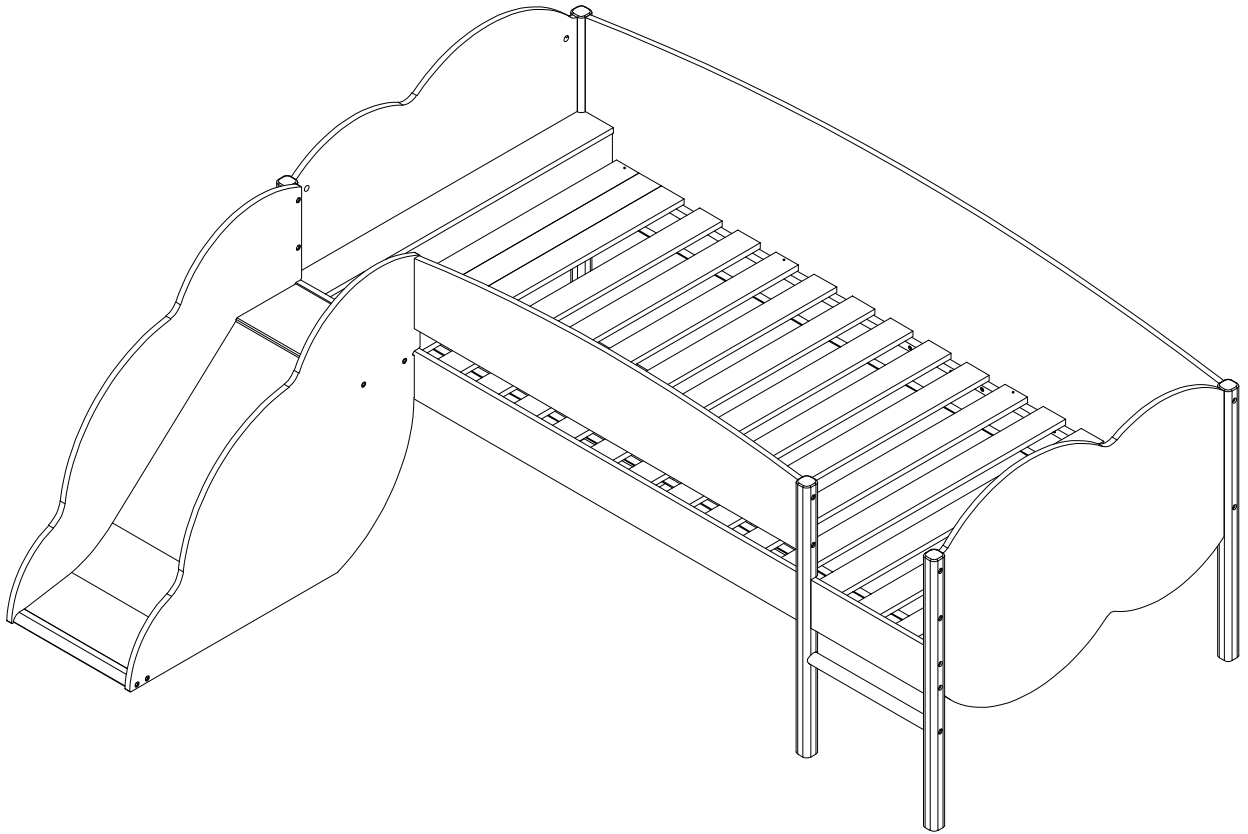

End Option 4



8

L	x 4	E	x 4	K	x 4	G	x 1
							
Ø9.5 x 11		Ø8 x 30		Ø6x70			

Option 5

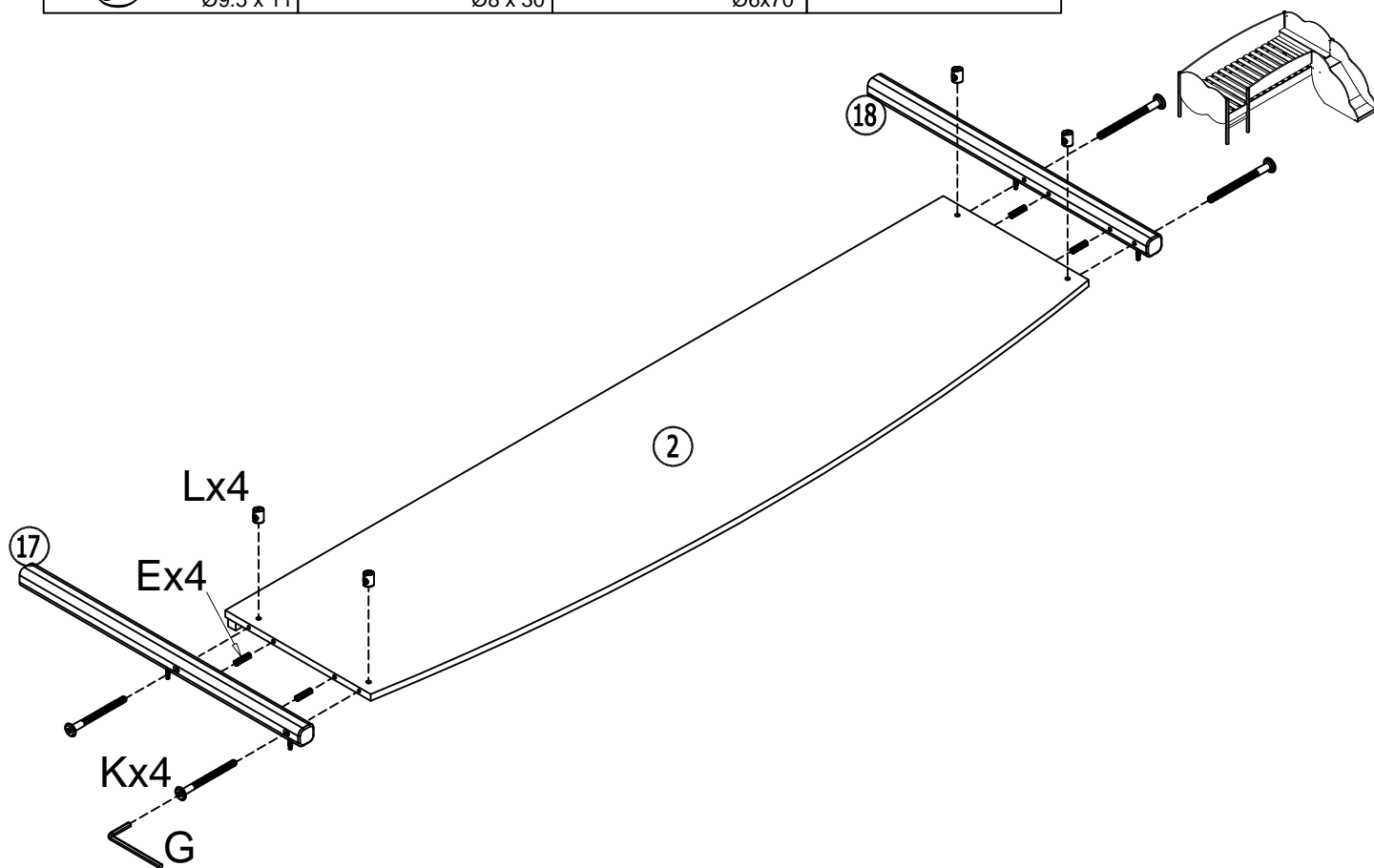

9

Q	x 1
	
Ø6 x 70	

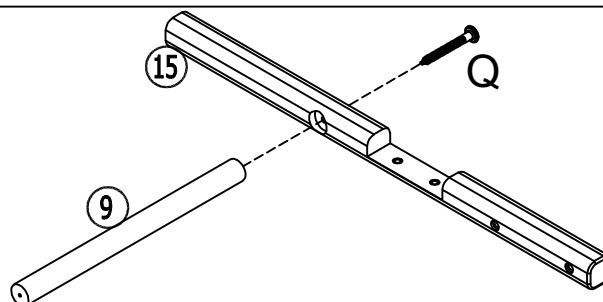





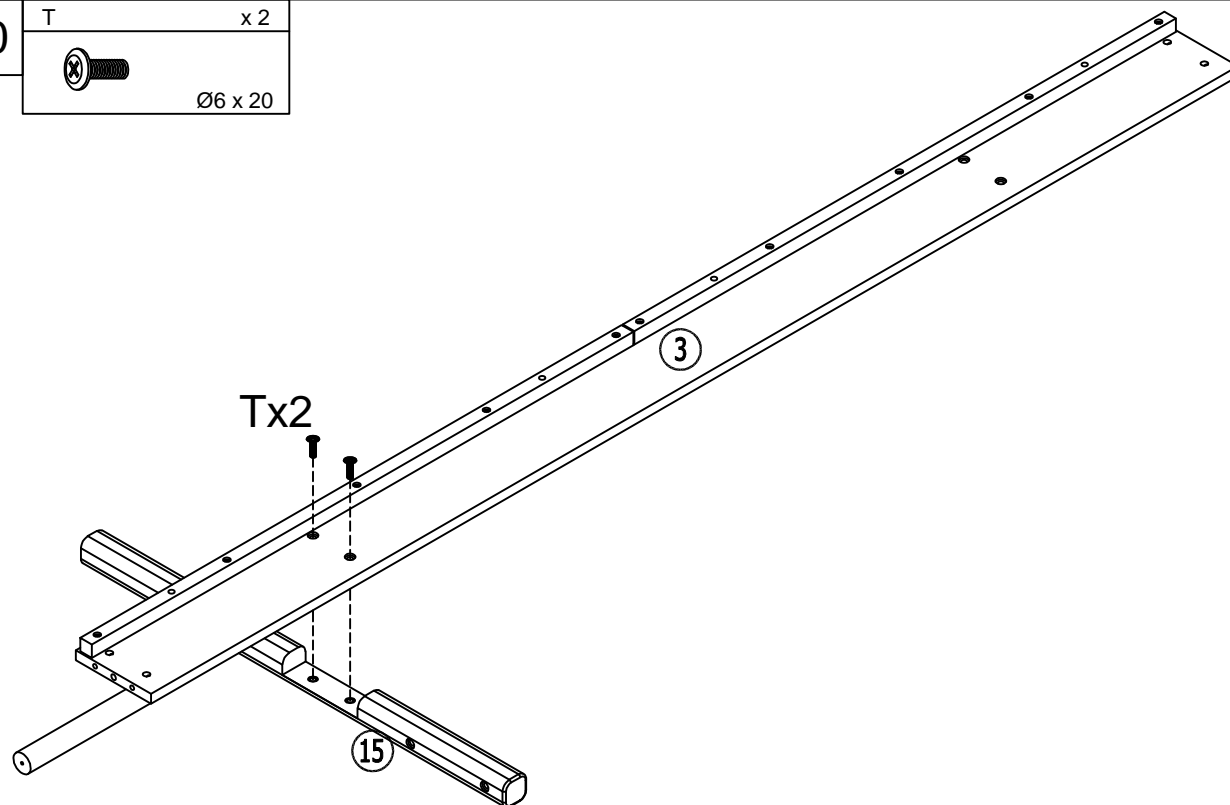

10

T	x 2
	
Ø6 x 20	

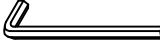



11

L	x 4	E	x 2	K	x 4	G	x 2
	Ø9.5 x 11		Ø8 x 30		Ø6x70		
M	x 3	R	x 2	T	x 1	Q	x 1
			Ø6x30		Ø6 x 20		Ø6 x 70

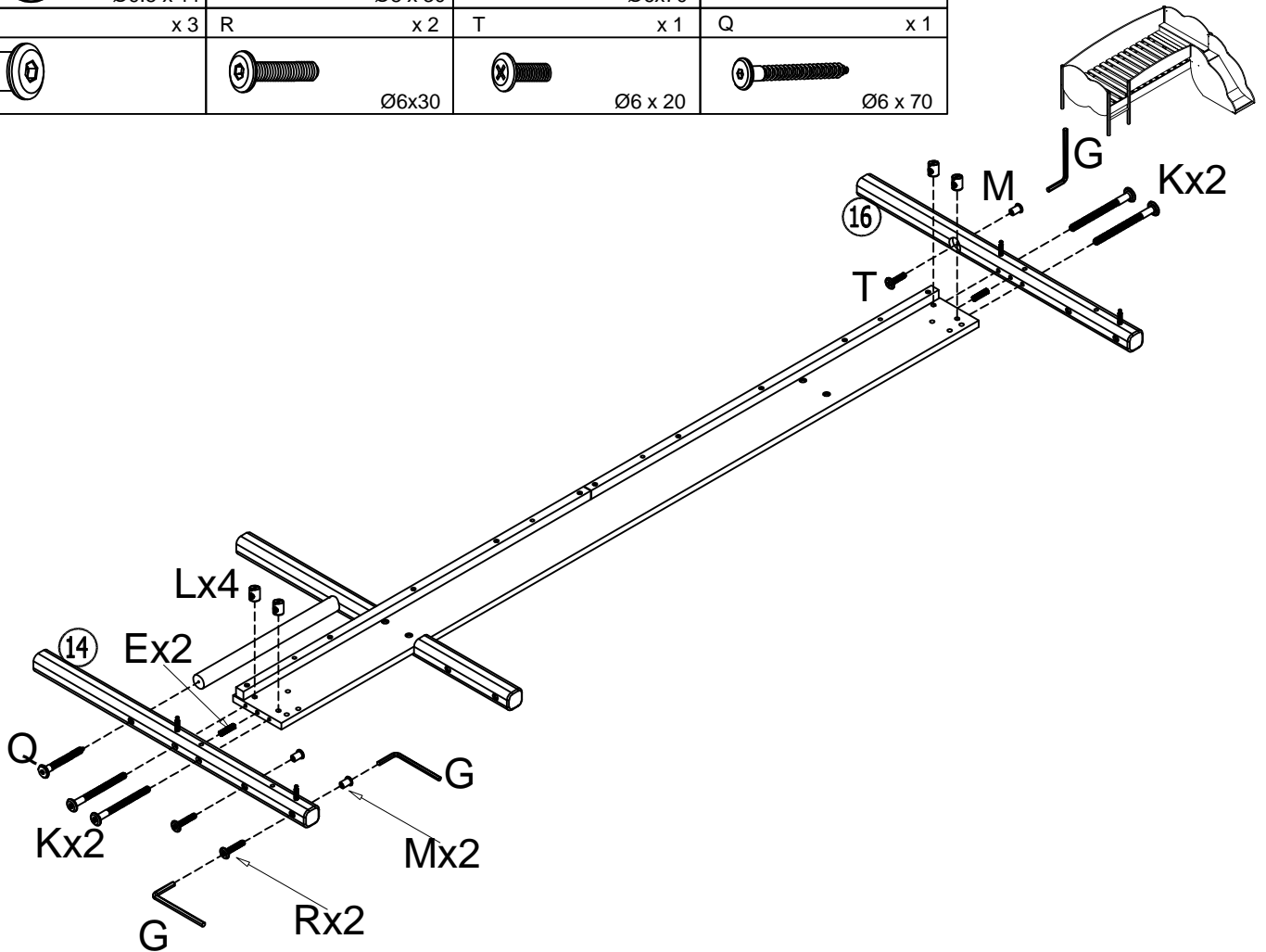
Option 5



12

B	x 4
	Ø14.5x11.9
E	x 4
	Ø8 x 30

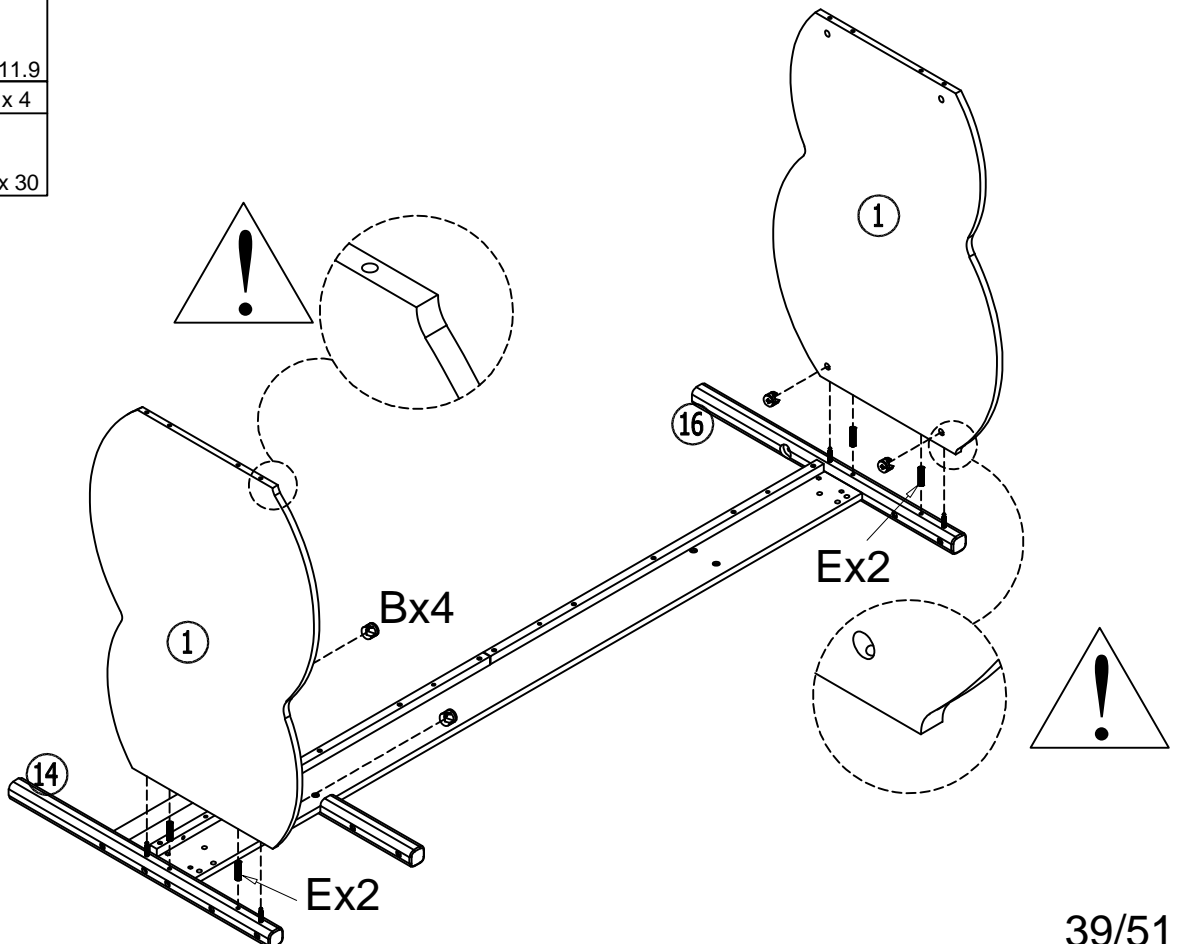
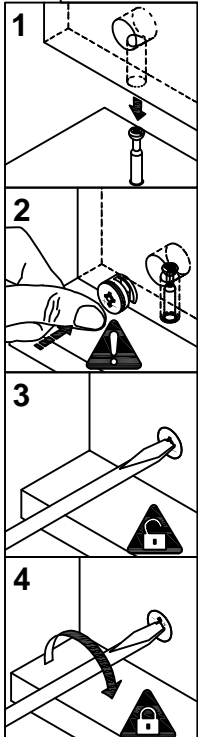

13

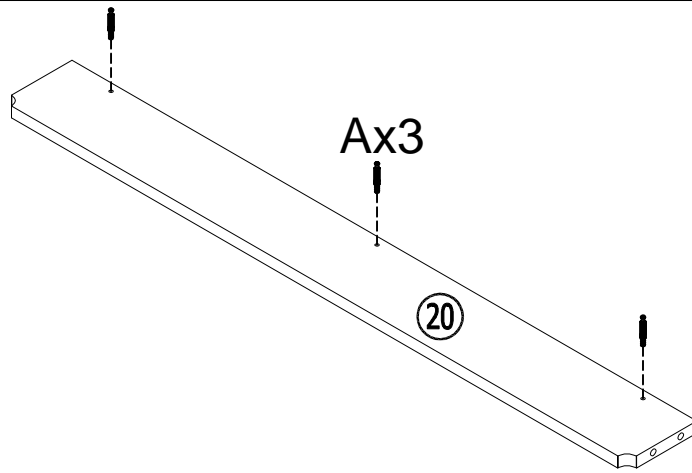
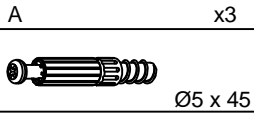

Option 5

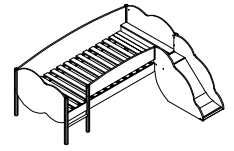

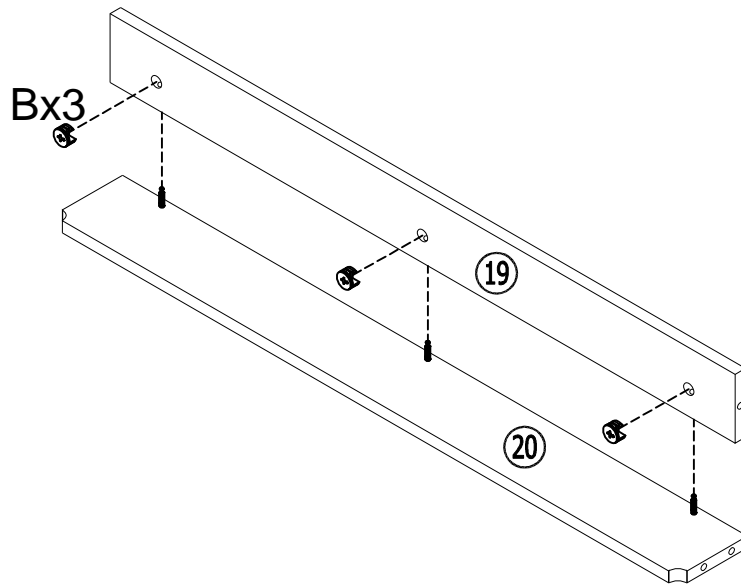
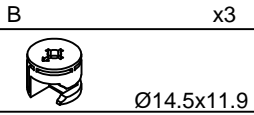

14

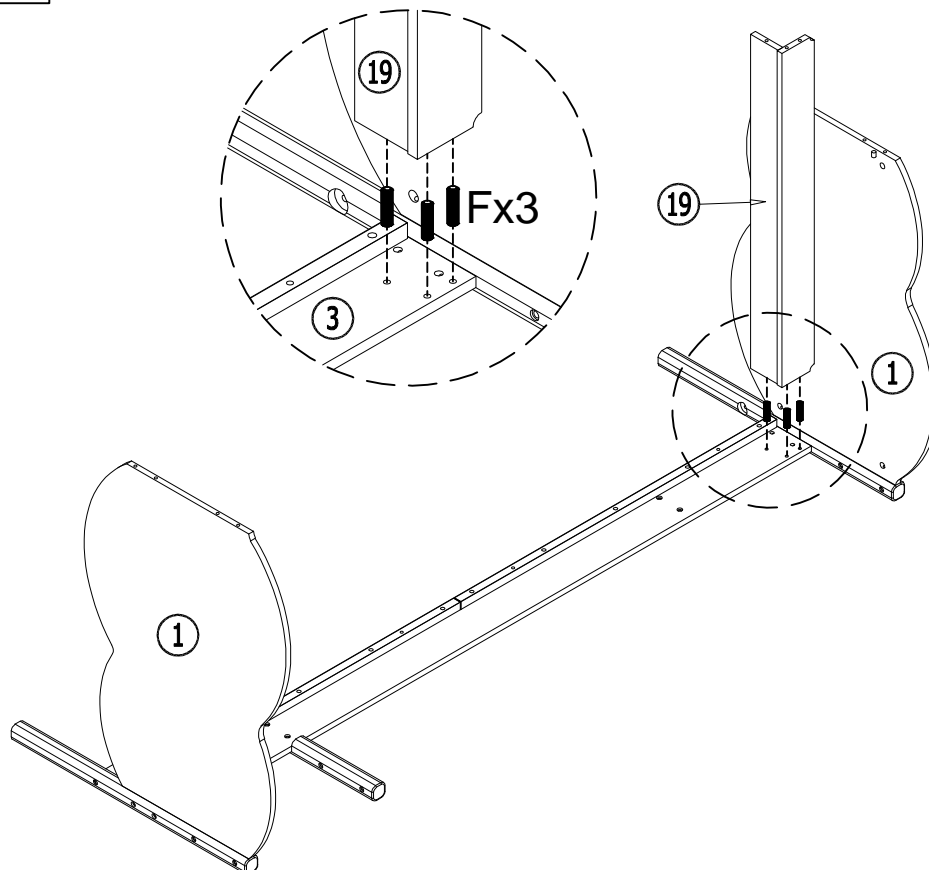
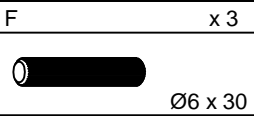

15





16

B	x4
	Ø14.5x11.9
E	x4
	Ø8 x 30
F	x3
	Ø6 x 30

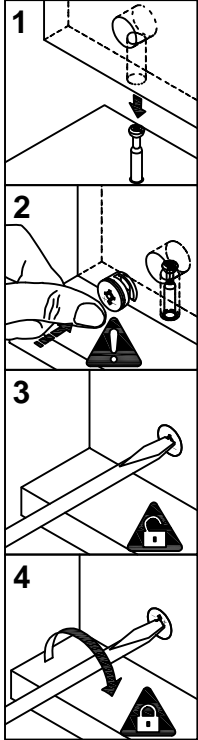
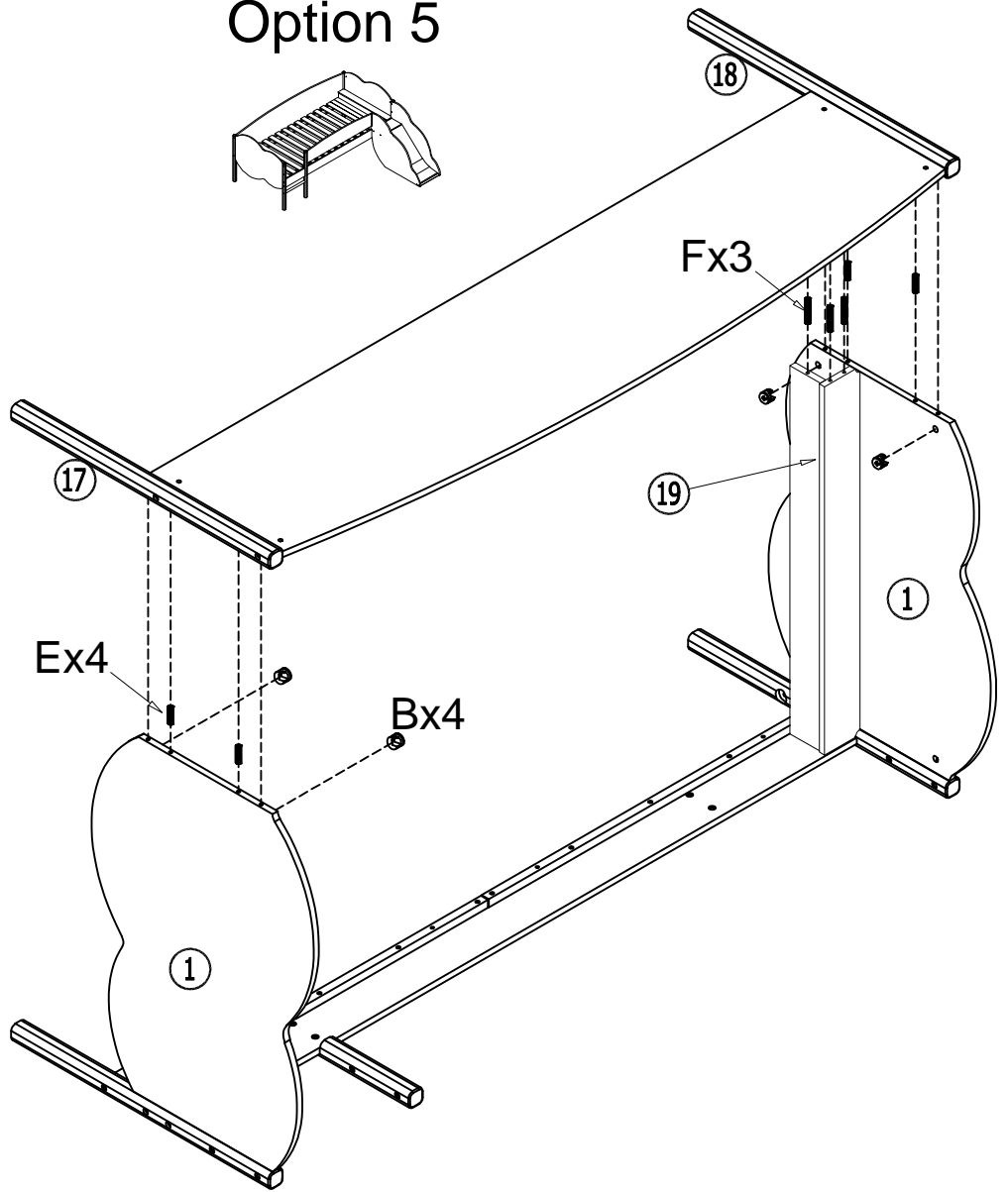
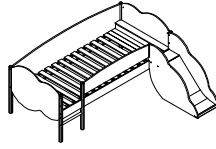
Option 5



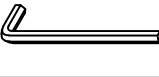

17

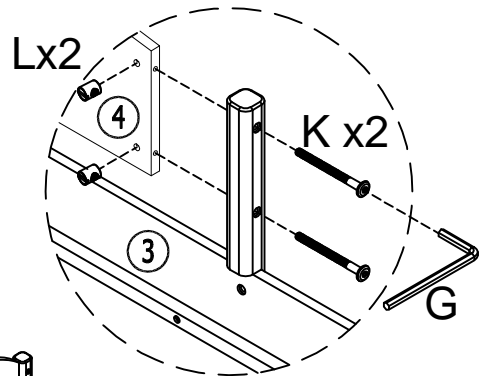
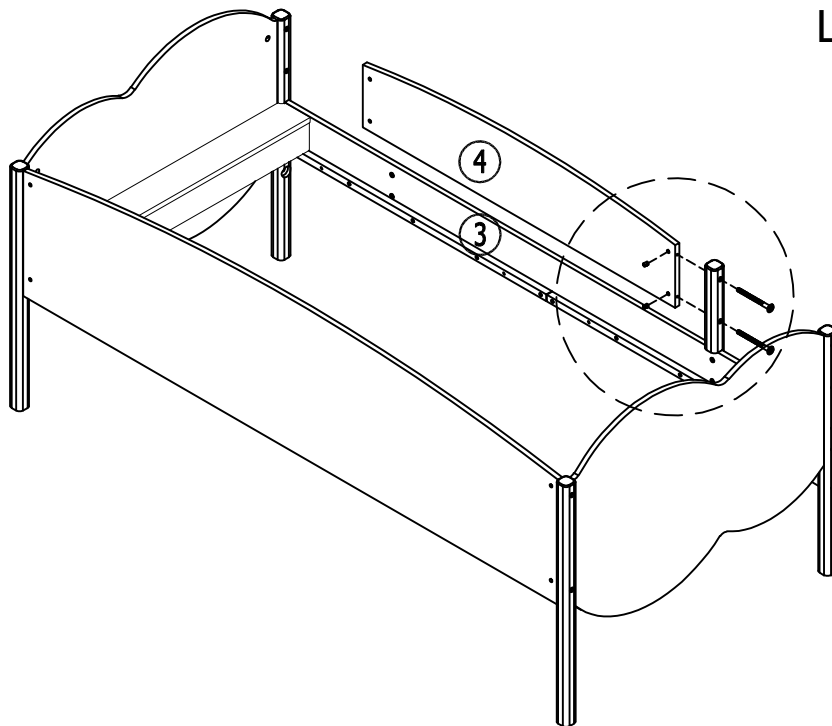
L	x2	K	x2	G	x1
	Ø9.5 x 11		Ø6x70		





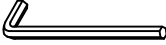

16

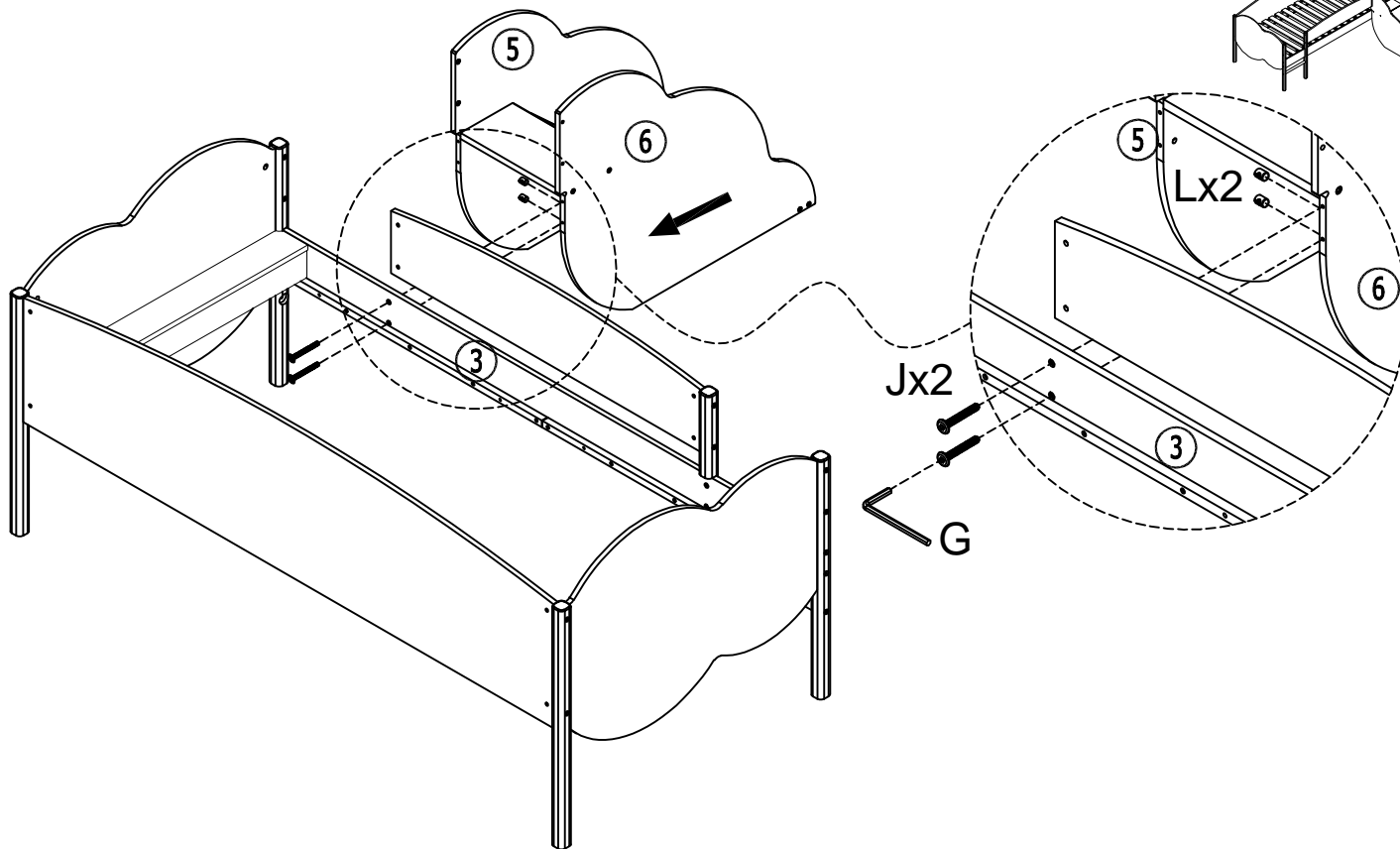
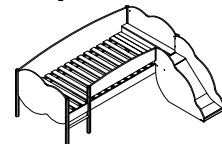
L	x2	J	x2	G	x1
					
Ø9.5 x 11		Ø6x50			

Option 5



17

L	x2	J	x2	M	x2	G	x2	U	x2
									
Ø9.5 x 11		Ø6x50						Ø6x45	

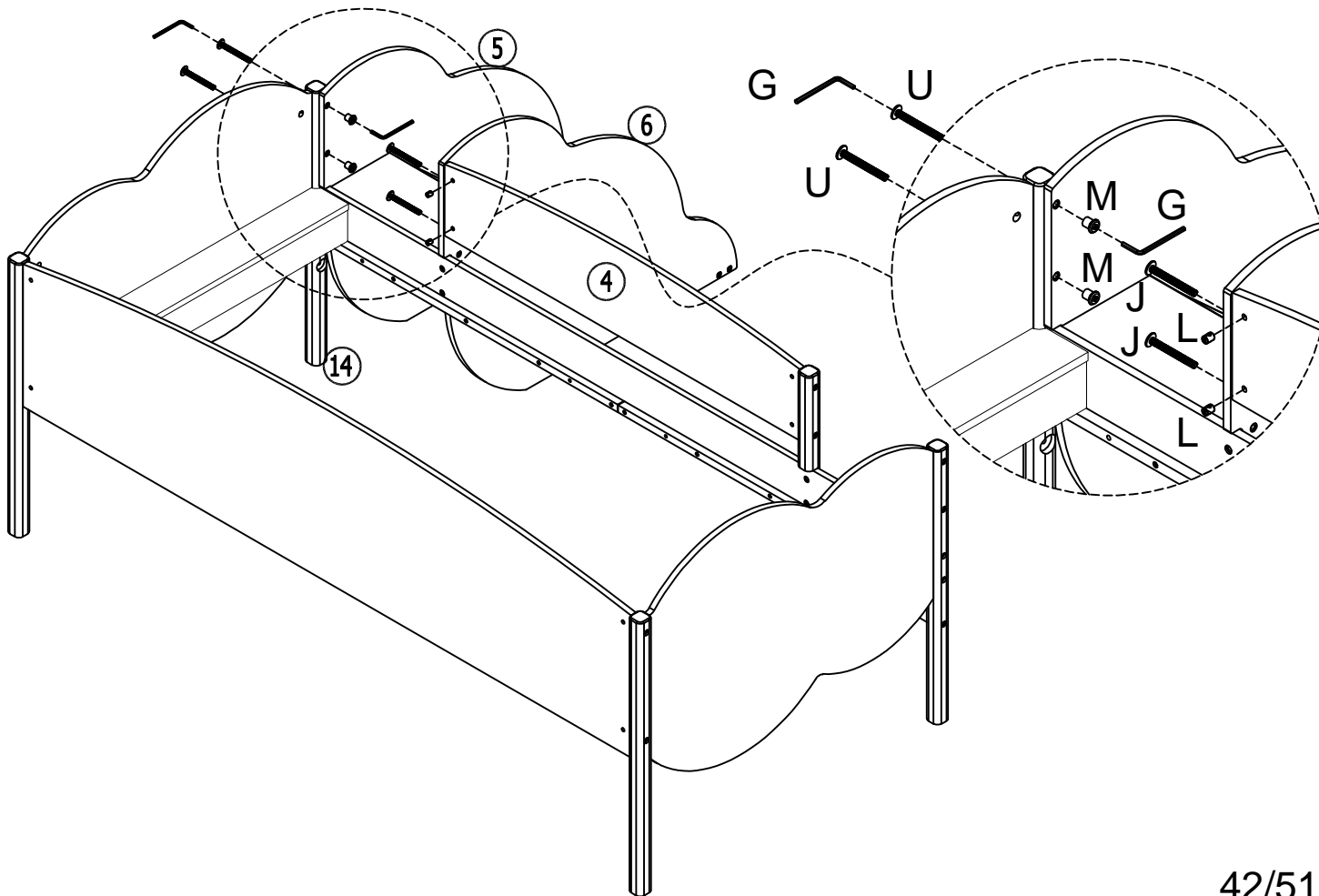

18

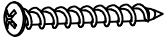
H	x 8
	
Ø4 X 30	

Option 5

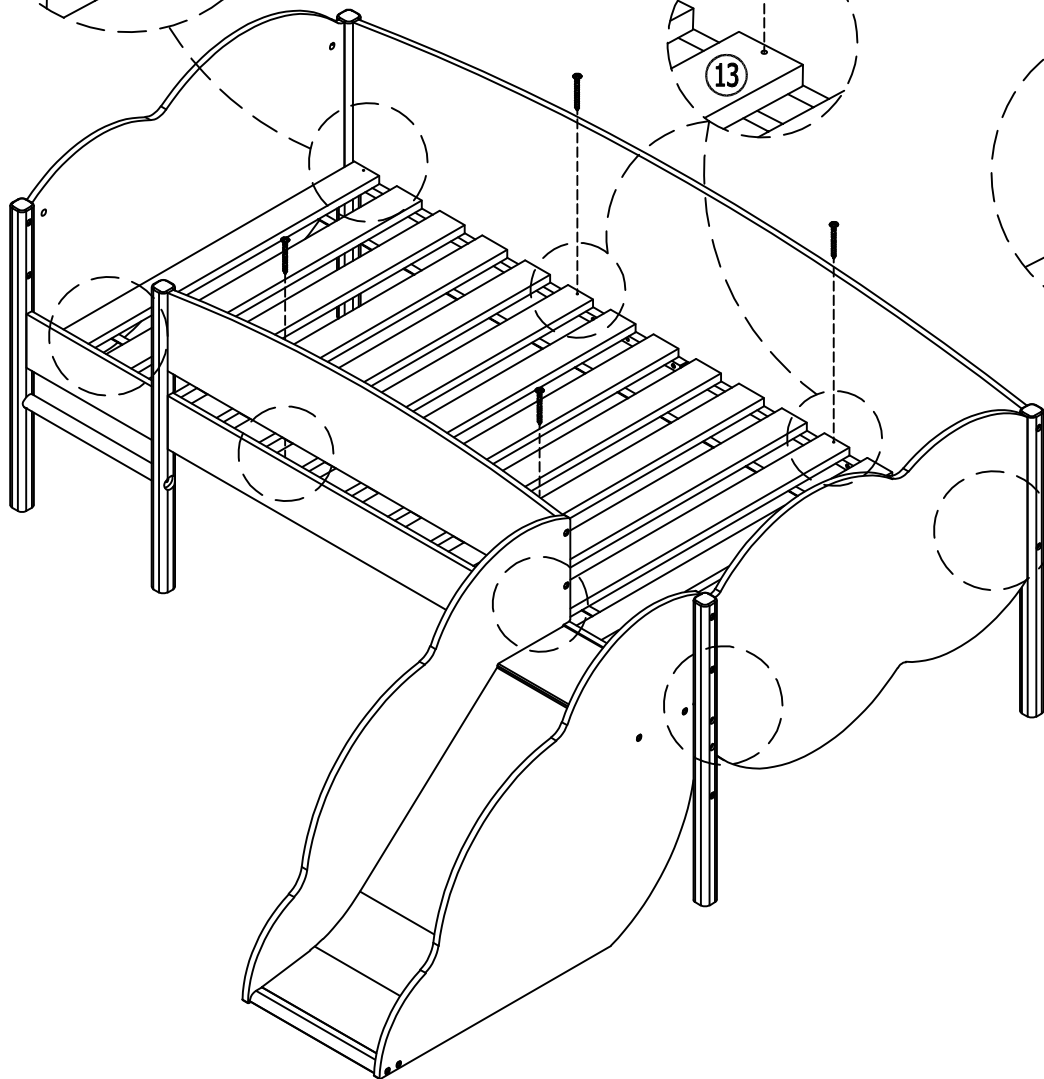
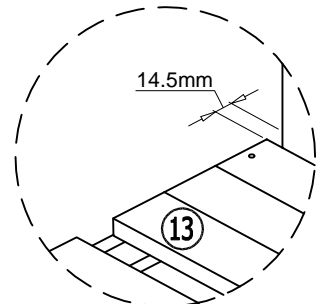
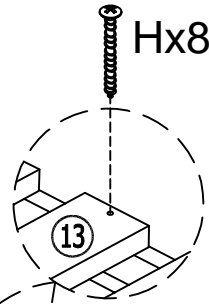
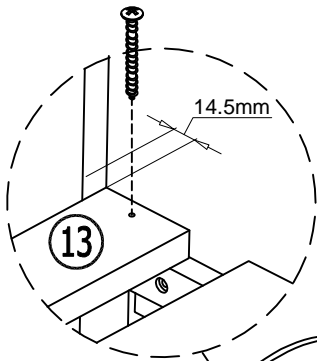
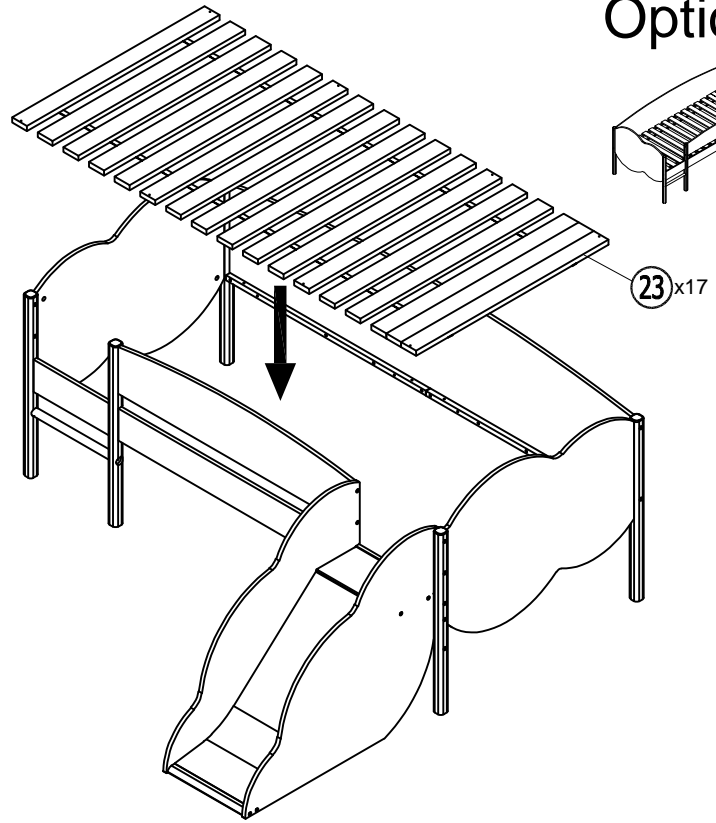
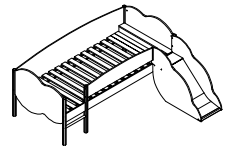

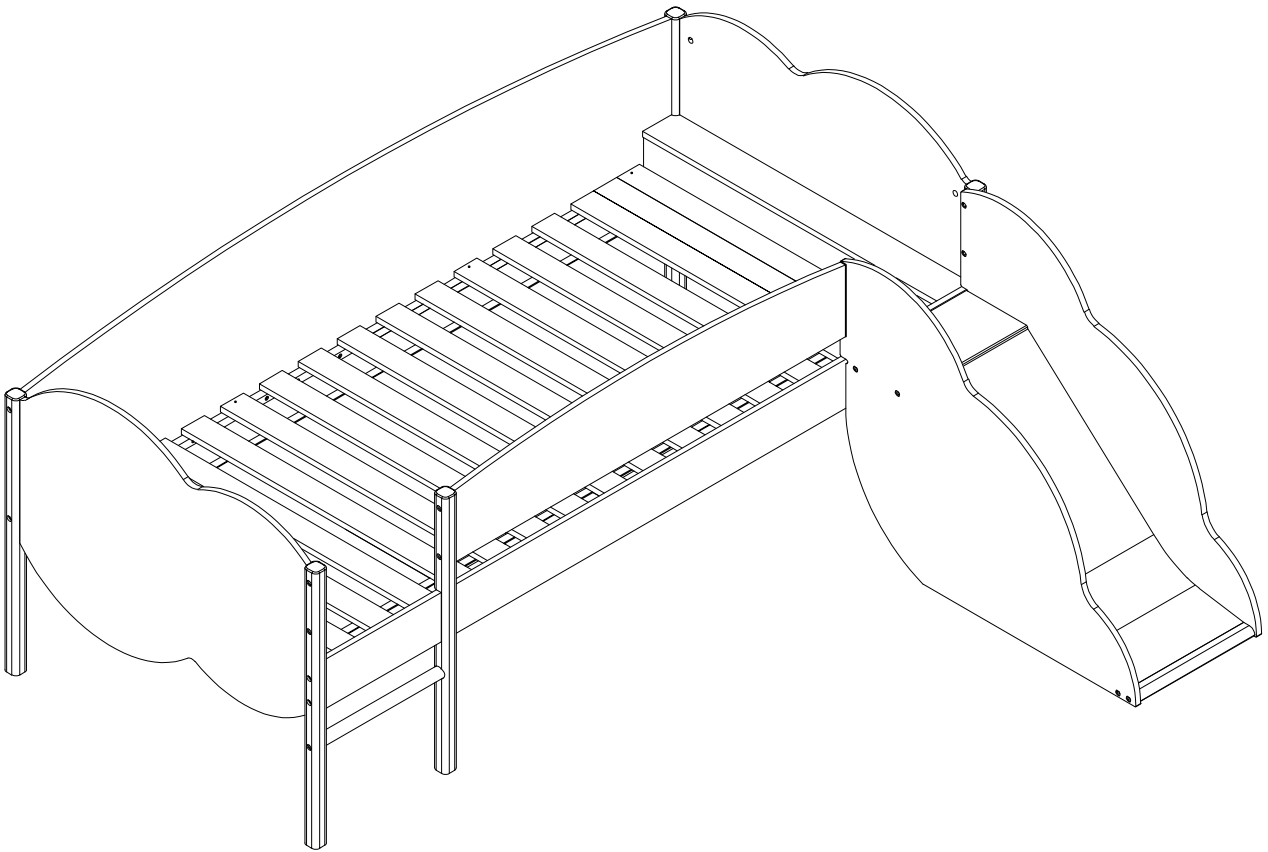

End Option 5



Option 6

8

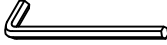
L	x 4	E	x 4	K	x 4	G	x 1
							
Ø9.5 x 11		Ø8 x 30		Ø6x70			

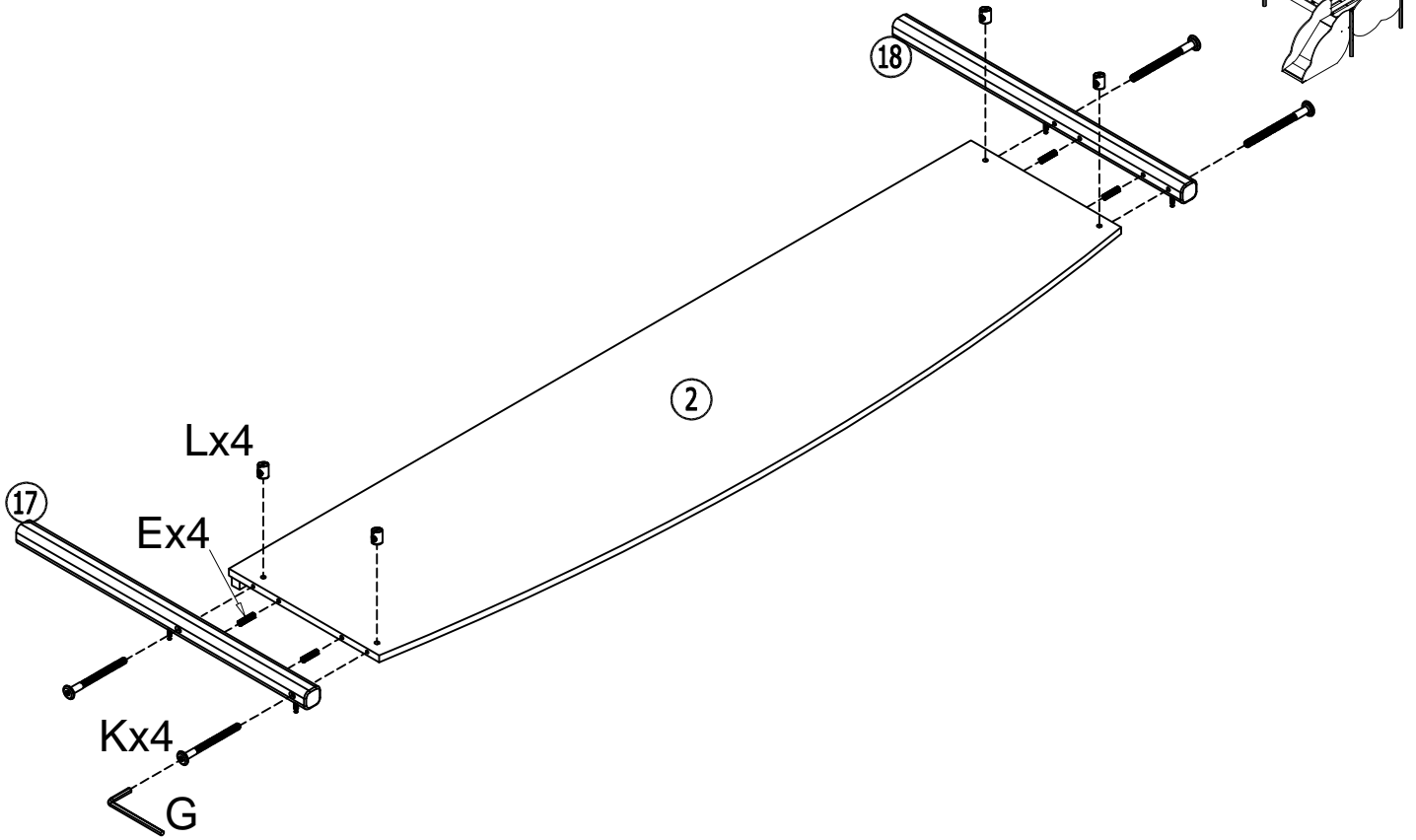

9

Q	x 1
	
Ø6 x 70	

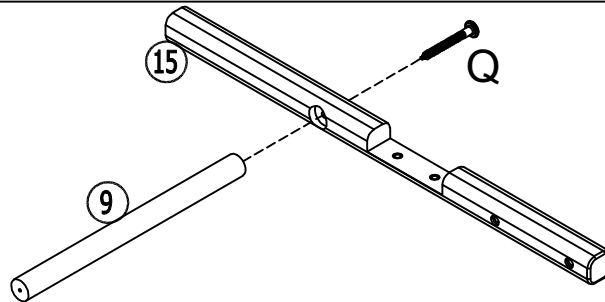





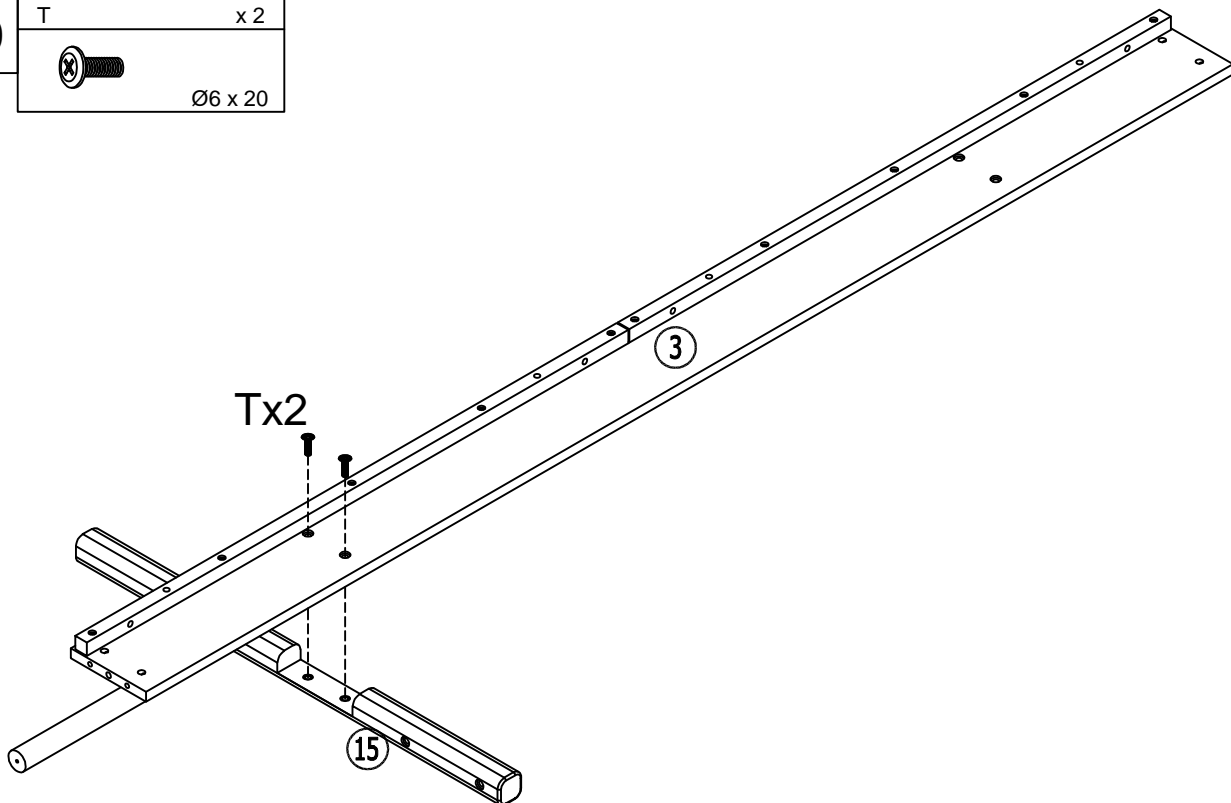

10

T	x 2
	
Ø6 x 20	

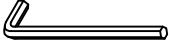

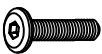

11

L	x 4	E	x 2	K	x 4	G	x 2
	Ø9.5 x 11		Ø8 x 30		Ø6x70		
M	x 3	R	x 2	T	x 1	Q	x 1
			Ø6x30		Ø6 x 20		Ø6 x 70

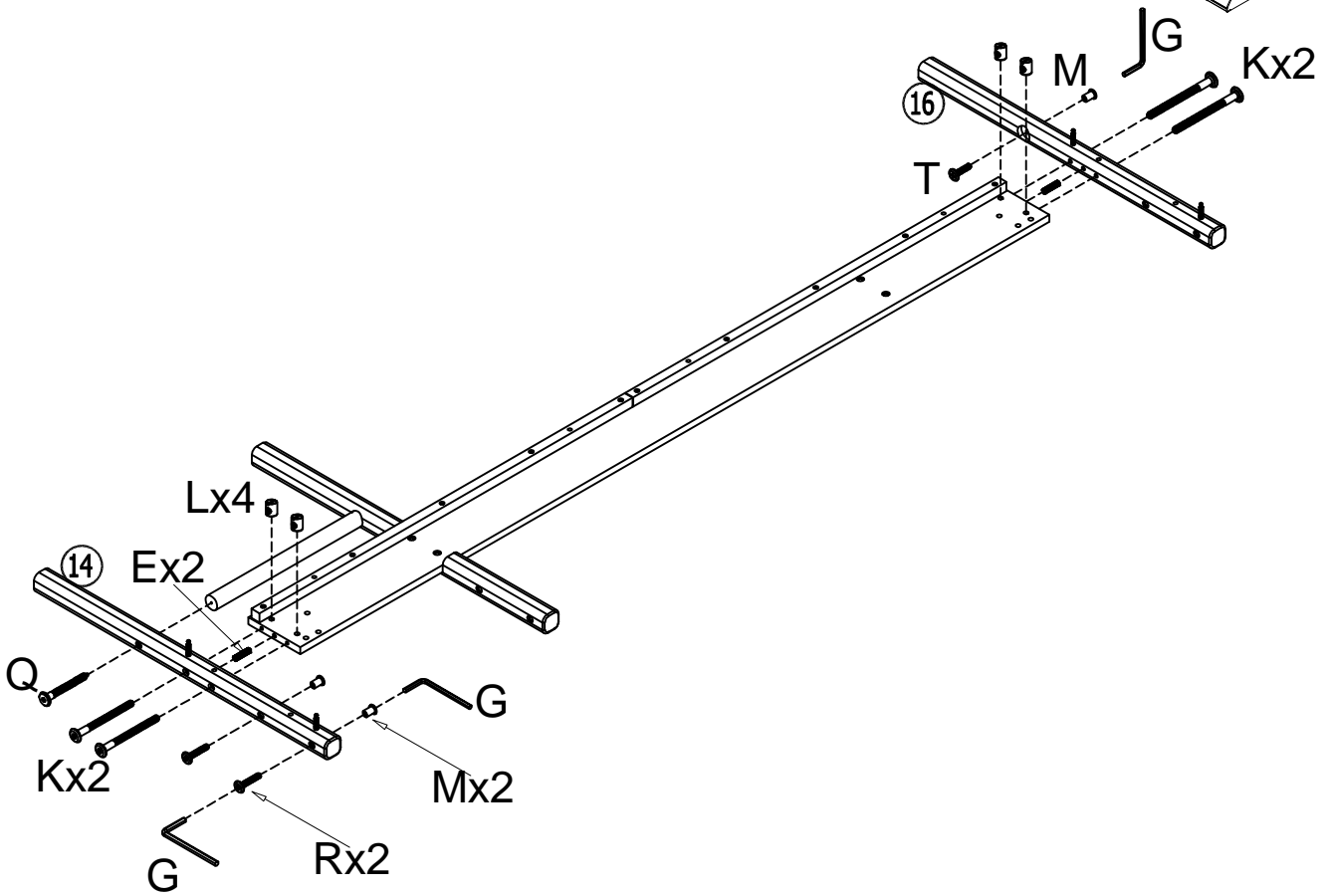
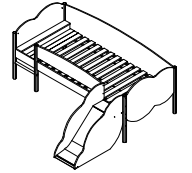
Option 6



12

B	x 4
	Ø14.5x11.9
E	x 4
	Ø8 x 30

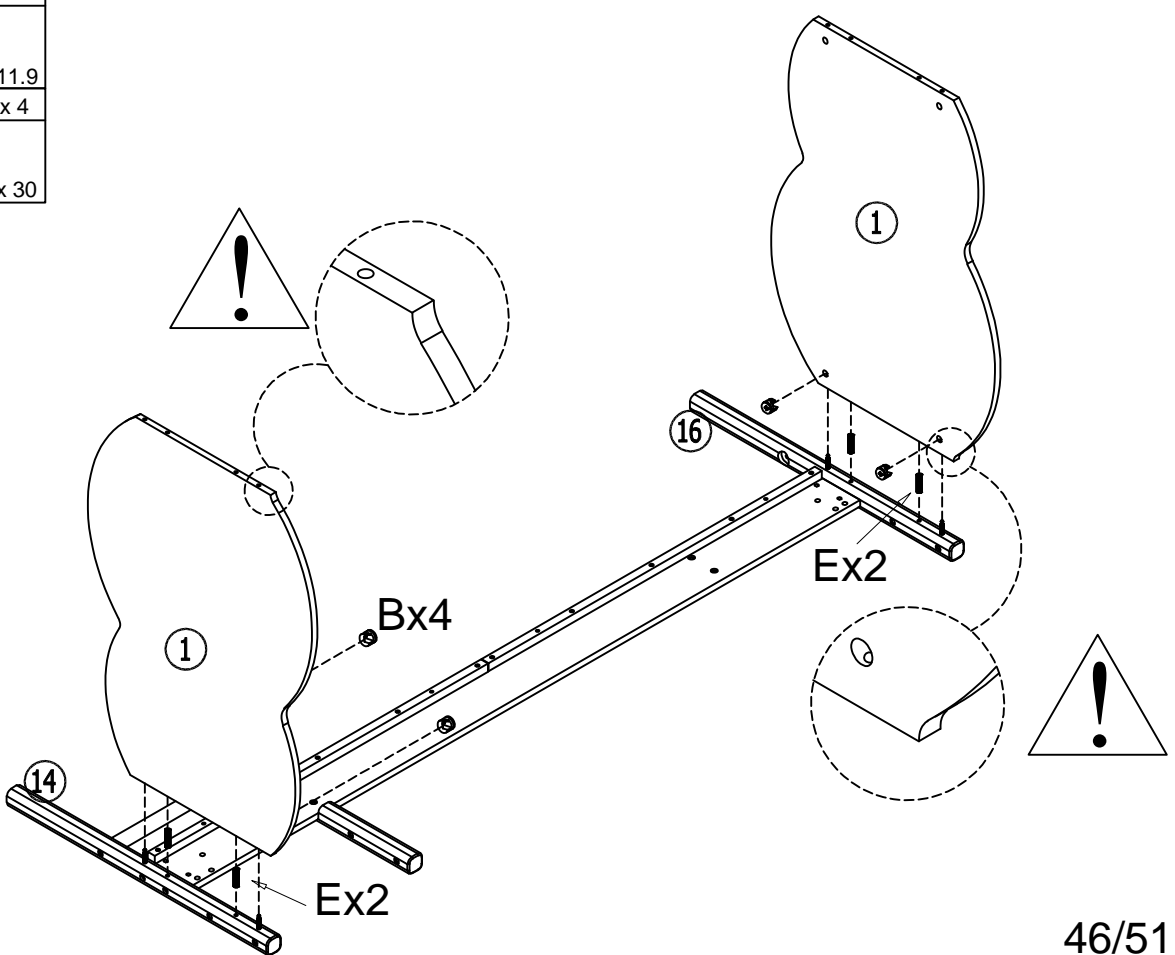
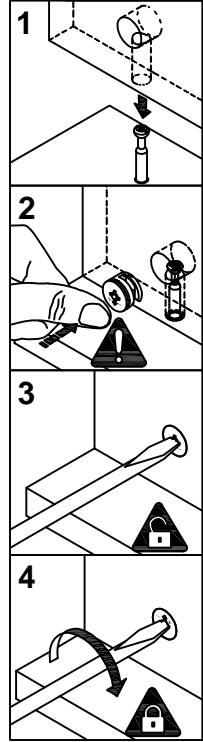

13

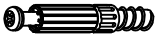
A	x3
	
Ø5 x 45	

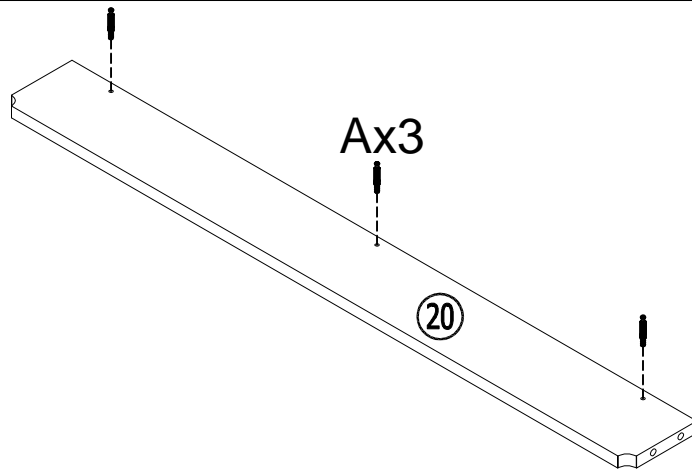

Option 6

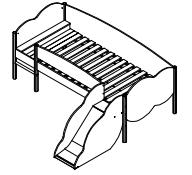

14

B	x3
	
Ø14.5x11.9	

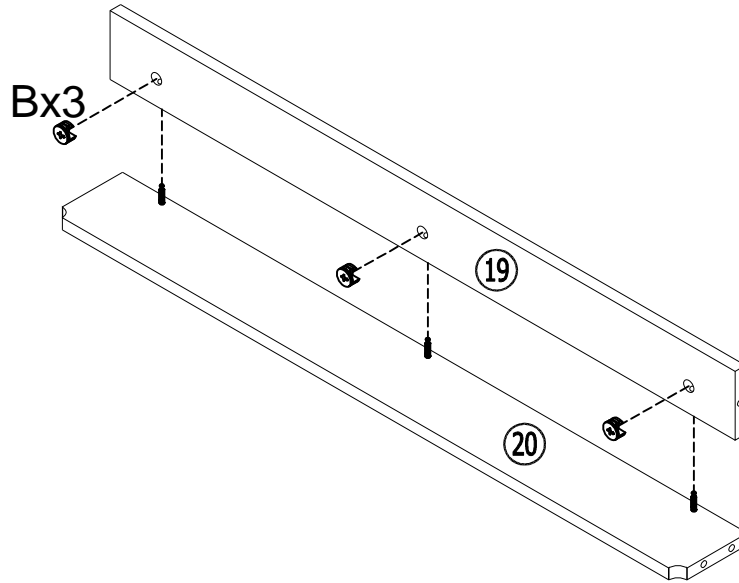

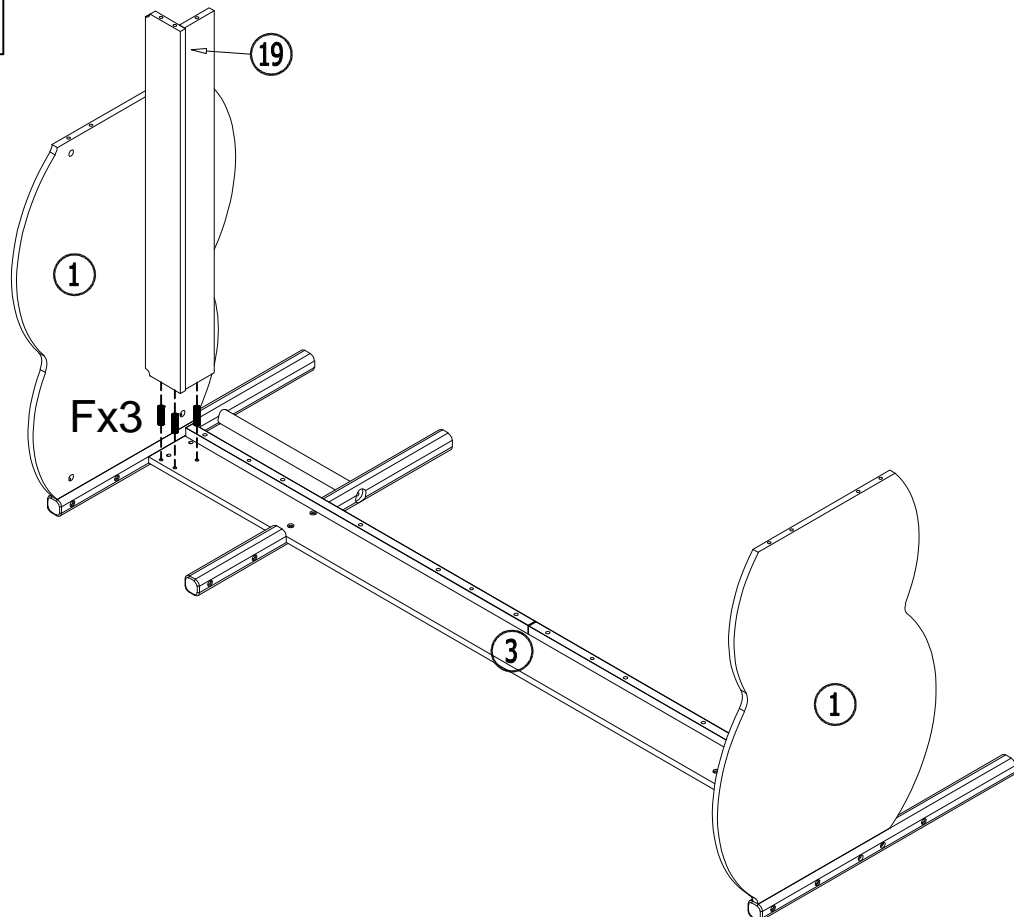

15

F	x3
	
Ø6 x 30	





16

B	x4
	Ø14.5x11.9
E	x4
	Ø8 x 30
F	x3
	Ø6 x 30

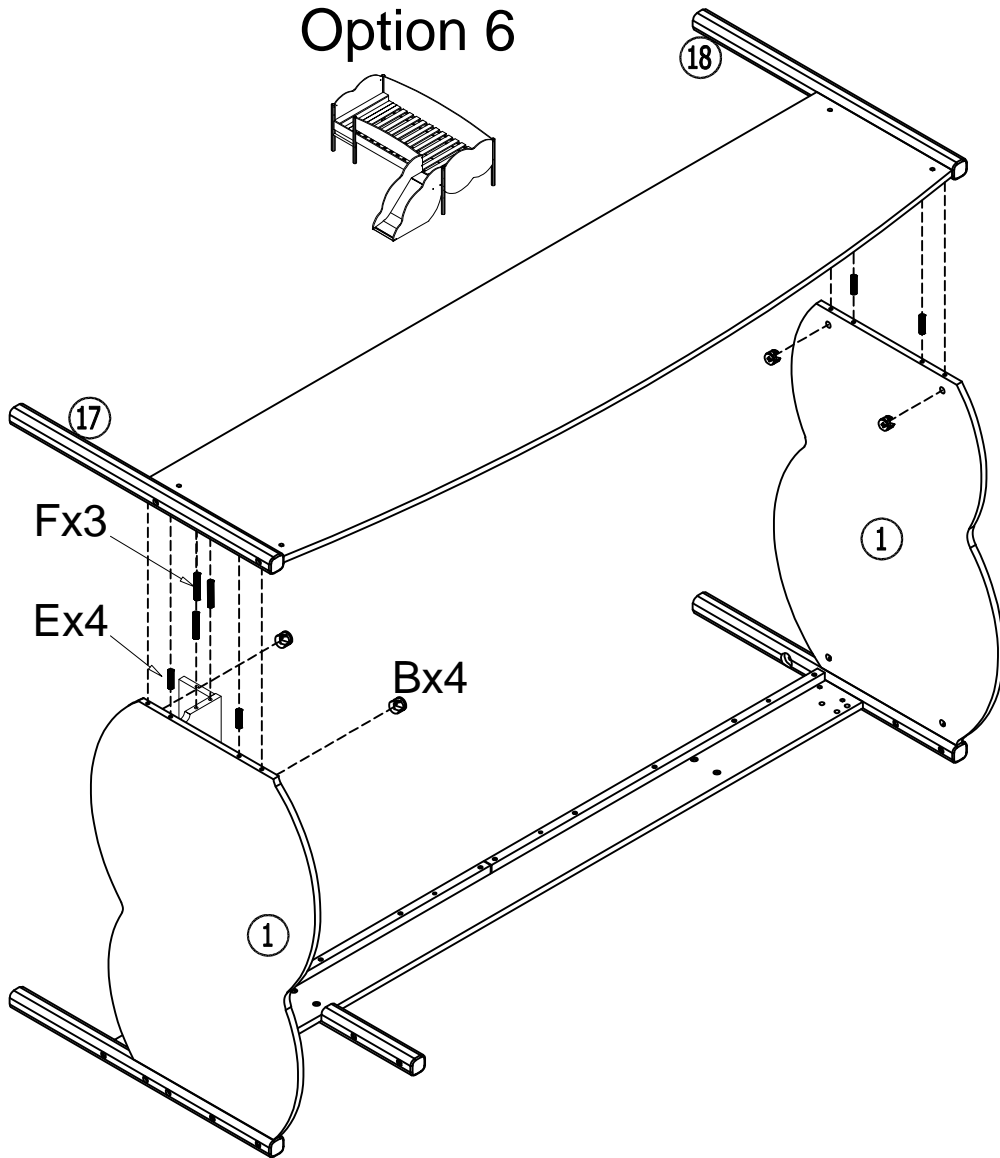
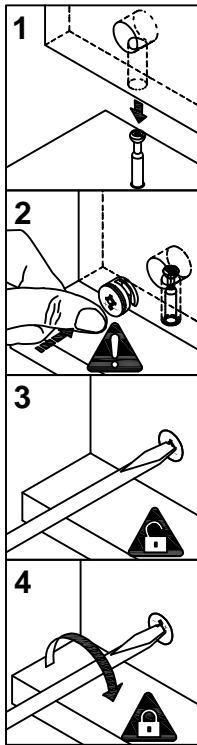
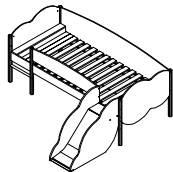
Option 6



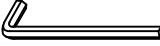

17

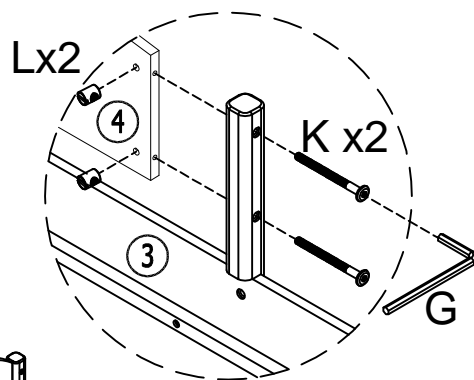
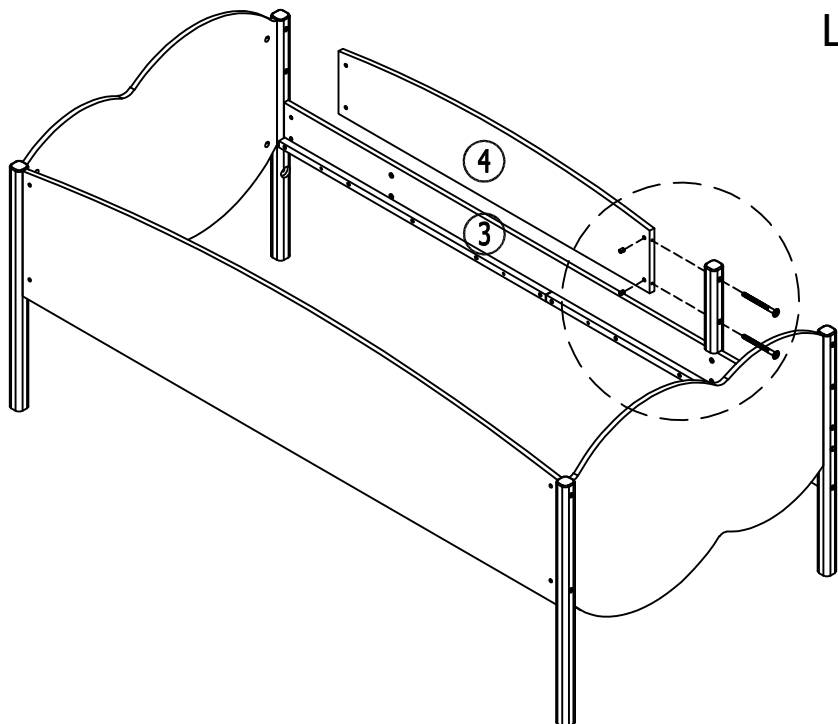
L	x2	K	x2	G	x1
	Ø9.5 x 11		Ø6x70		





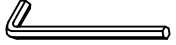

16

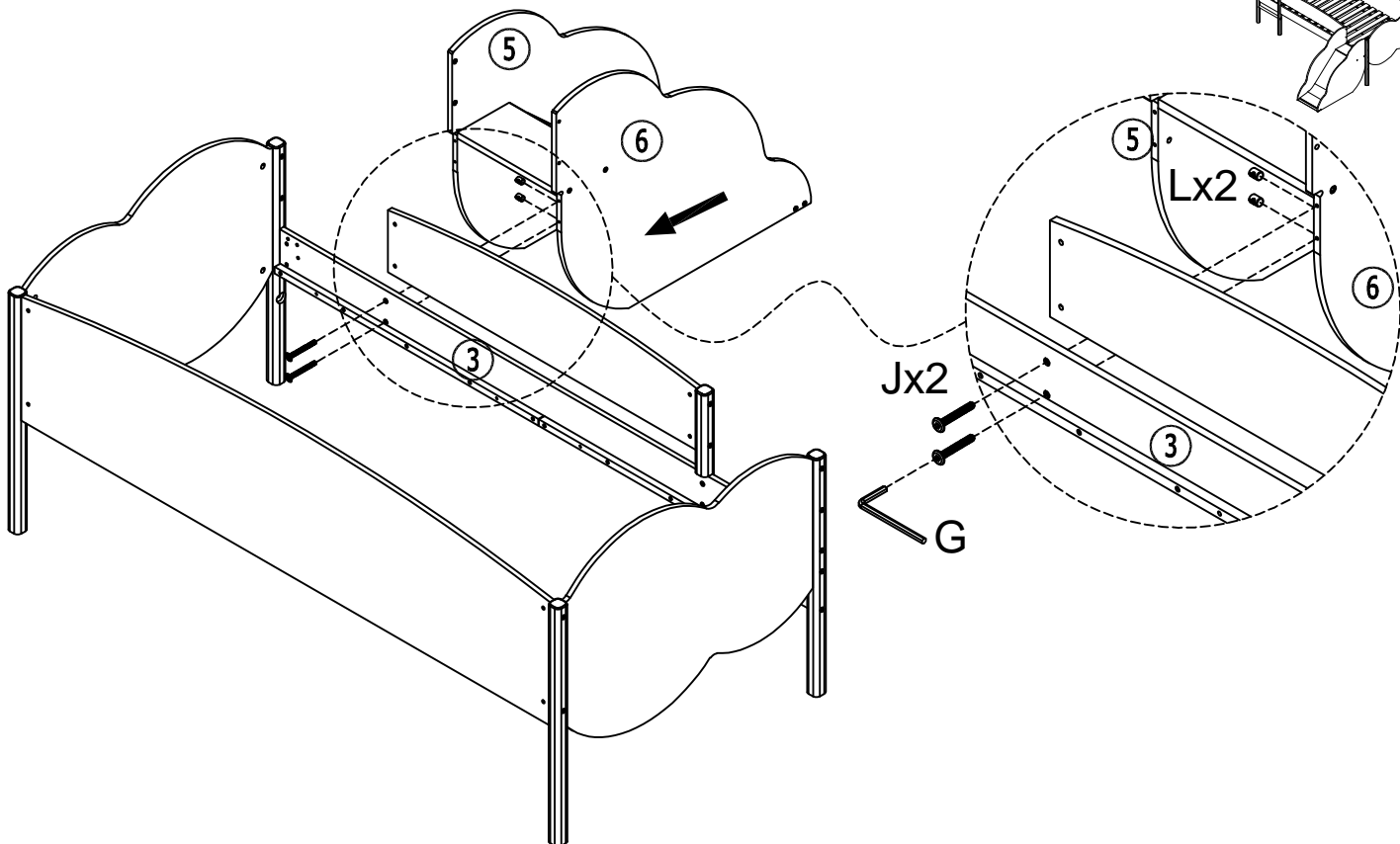
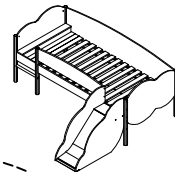
L	x2	J	x2	G	x1
					
Ø9.5 x 11		Ø6x50			

Option 6

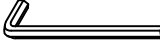

17

L	x2	J	x2	M	x2	G	x2	U	x2
									
Ø9.5 x 11		Ø6x50						Ø6x45	

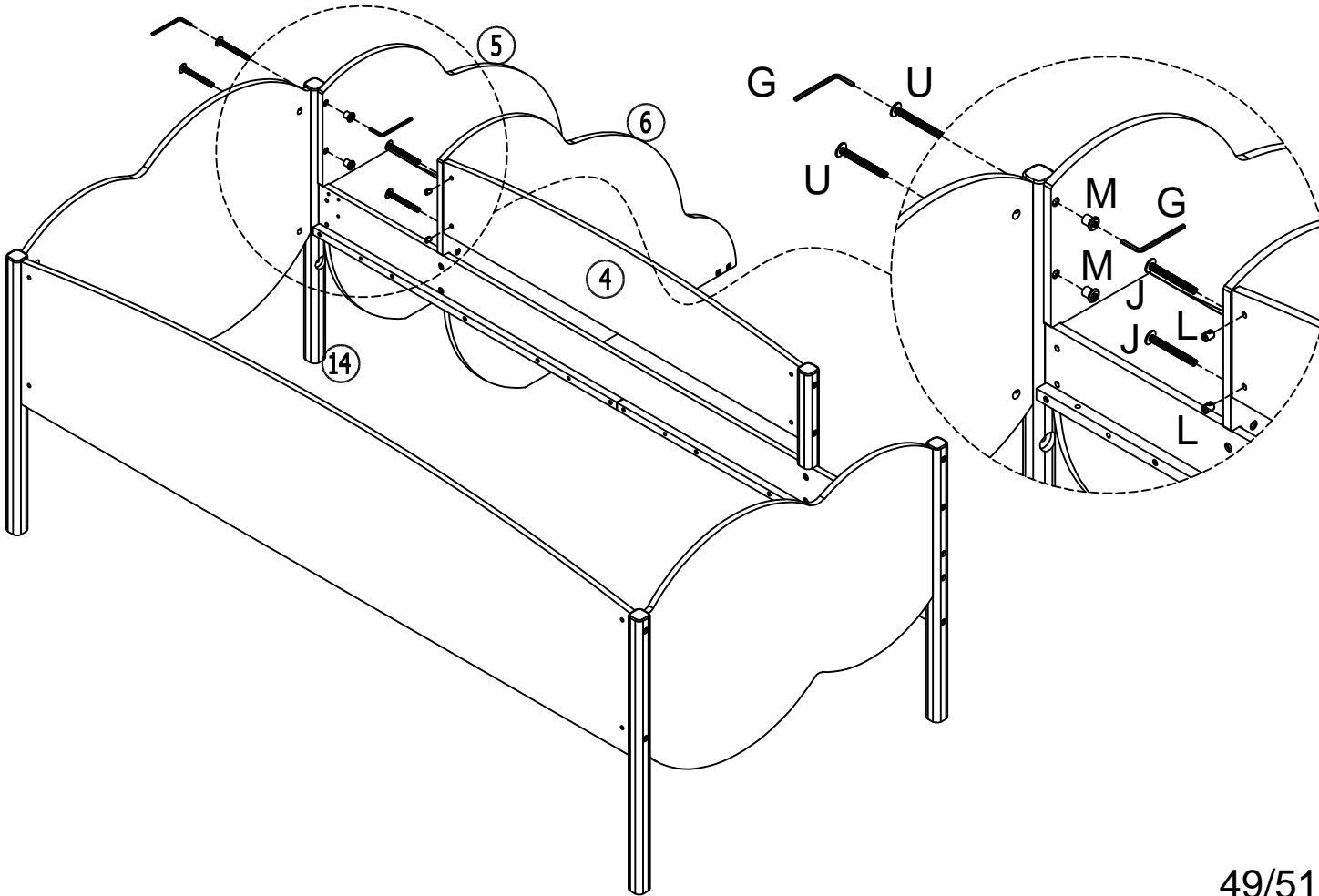

18

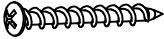
H	x 8
	
Ø4 X 30	

Option 6

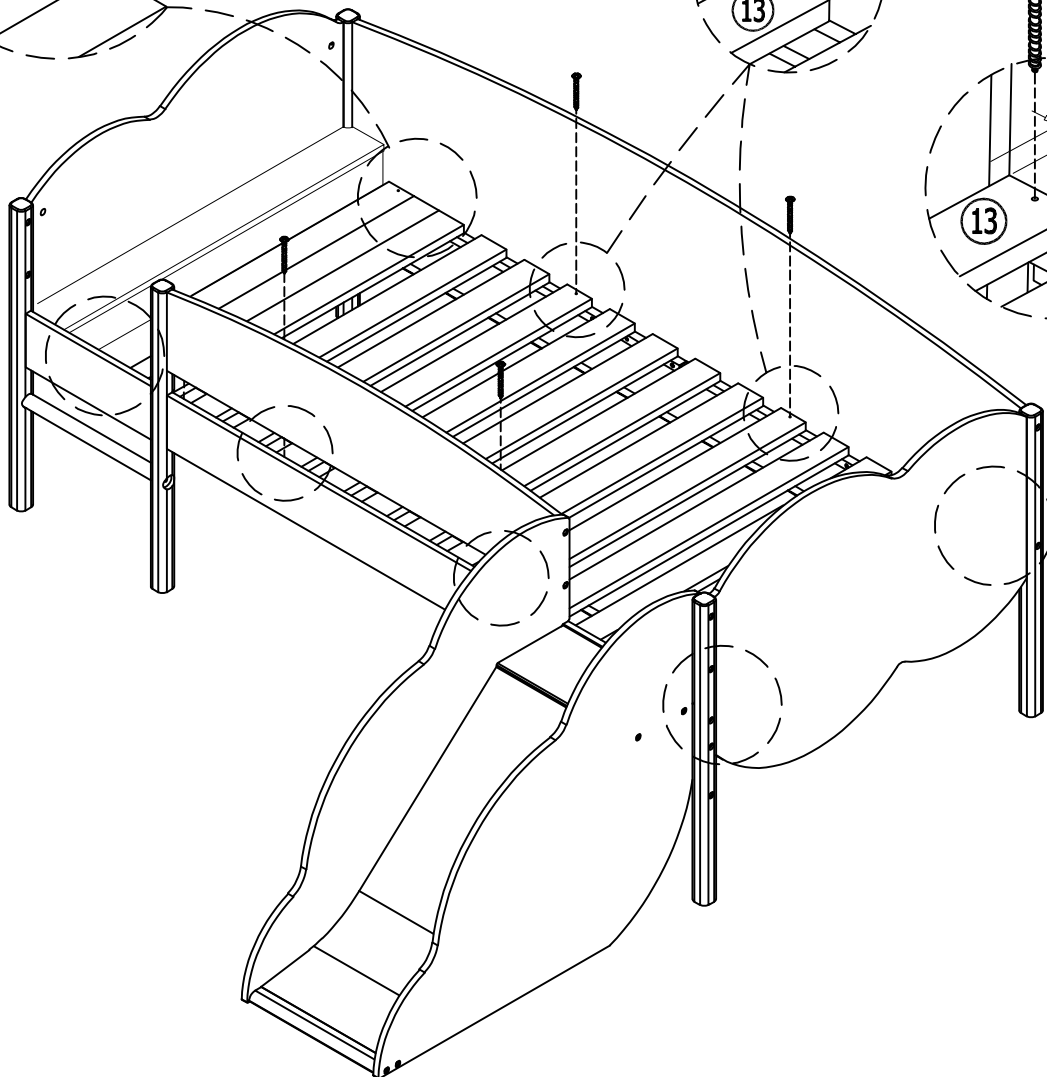
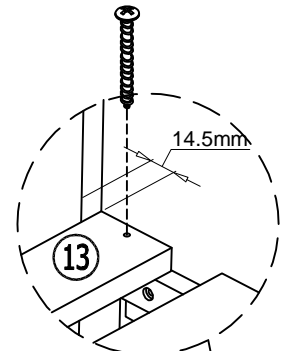
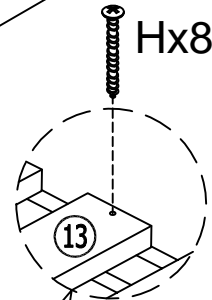
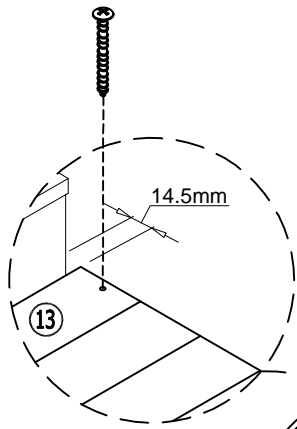
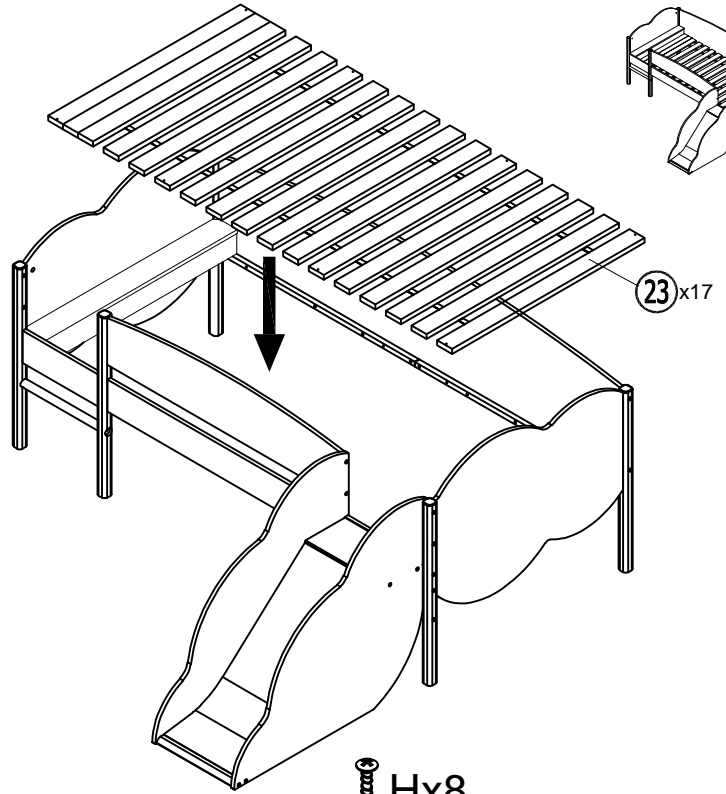
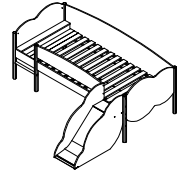

End Option 6

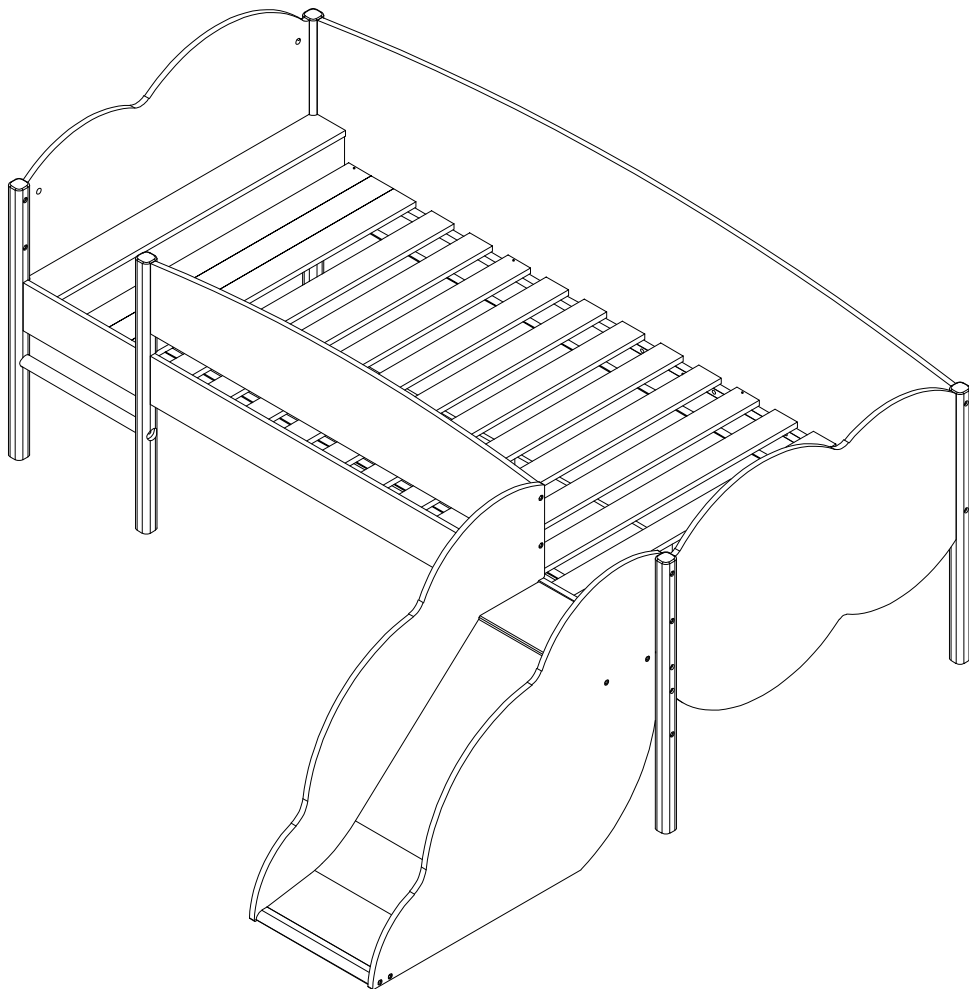

FR

Donnez ou recyclez vos meubles.

Association ou Magasin ou Déchèterie

<https://quefairede mesdechets.fr>

FR