

Installation sanleitung Installation Instruction Instruction d'installation

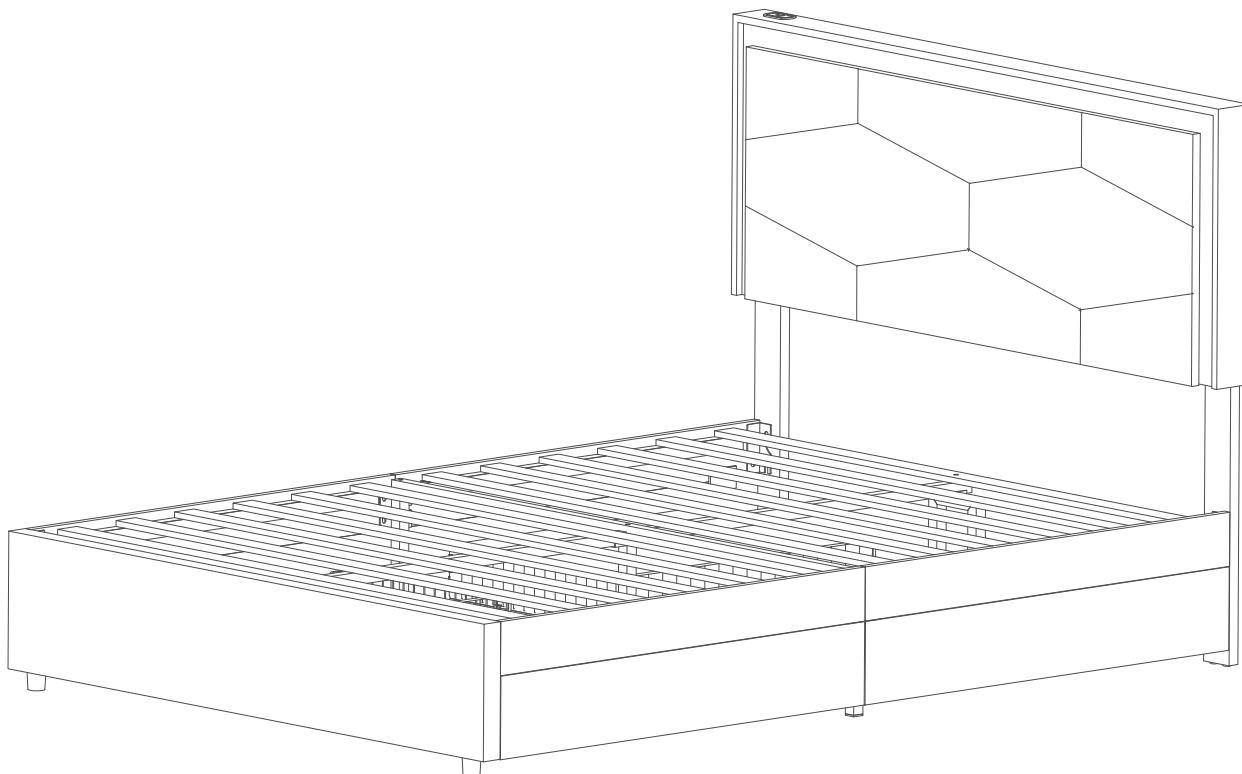

FR

Vous êtes responsable de remettre tous les appareils électriques et électroniques usagés à des points de collecte correspondants.

Pour en savoir plus:
www.quefairedesdechets.fr



Unser Produkt wird Ihnen in 2 Paketen geliefert. Die Lieferzeiten dieser 2 Pakete können abweichen, bitte haben Sie etwas Geduld und vielen Dank für Ihr Verständnis.

Our product will be delivered to you in 2 packages. The delivery times of these 2 packages may differ, please be patient and thank you for your understanding.

Notre produit vous sera livré en 2 colis. Les délais de livraison de ces 2 colis peuvent différer, soyez patient et merci pour votre compréhension.

N636P185484/N636P185485

Warnung

- 1 Die maximale Tragfähigkeit des Produkts beträgt 225 kg Überlastung vermeiden
- 2 Zur Sicherheit bitte die Anweisungen korrekt befolgen und gegebenenfalls professionelle Hilfe in Anspruch nehmen
- 3 Das Möbel nicht in der Nähe von Hitzequellen oder heißen Gegenständen platzieren, um Brandgefahr zu vermeiden
- 4 Das Möbel nicht in feuchten Umgebungen aufstellen, um Schäden am Material zu vermeiden
- 5 Regelmäßige Überprüfung aller Verbindungsstücke und Befestigungen, um sicherzustellen, dass sie fest sitzen und unerwartete Unfälle zu verhindern

Warning

- 1 The maximum load capacity of the product top panel is 225 kg Do not overload
- 2 For safety, please follow the instructions correctly and seek professional assistance if necessary
- 3 Do not place furniture near heat sources or hot items to avoid the risk of fire
- 4 Do not place furniture in damp environments to prevent material damage
- 5 Regelmäßige Überprüfung aller Verbindungsstücke und Befestigungen, um sicherzustellen, dass sie fest sitzen und unerwartete Unfälle zu verhindern

Avertissement

- 1 La capacité de charge maximale du produit est de 225 kg Ne pas surcharger
- 2 Zur Sicherheit bitte die Anweisungen korrekt befolgen und gegebenenfalls professionelle Hilfe in Anspruch nehmen
- 3 Ne pas placer les meubles près de sources de chaleur ou d'objets chauds pour éviter tout risque d'incendie
- 4 Ne pas placer les meubles dans des environnements humides pour éviter les dommages matériels
- 5 Vérifiez régulièrement tous les raccords et fixations pour vous assurer qu'ils sont bien serrés et pour éviter les accidents

Avviso

- 1 La capacità massima di carico del prodotto è di 225 kg Non sovraccaricare
- 2 Per motivi di sicurezza, seguire correttamente le istruzioni e richiedere assistenza professionale se necessario
- 3 Non posizionare i mobili vicino a fonti di calore o oggetti caldi per evitare il rischio di incendio
- 4 Non posizionare i mobili in ambienti umidi per evitare danni al materiale
- 5 Controllare regolarmente tutti i raccordi e i fissaggi per assicurarsi che siano saldi e per evitare incidenti





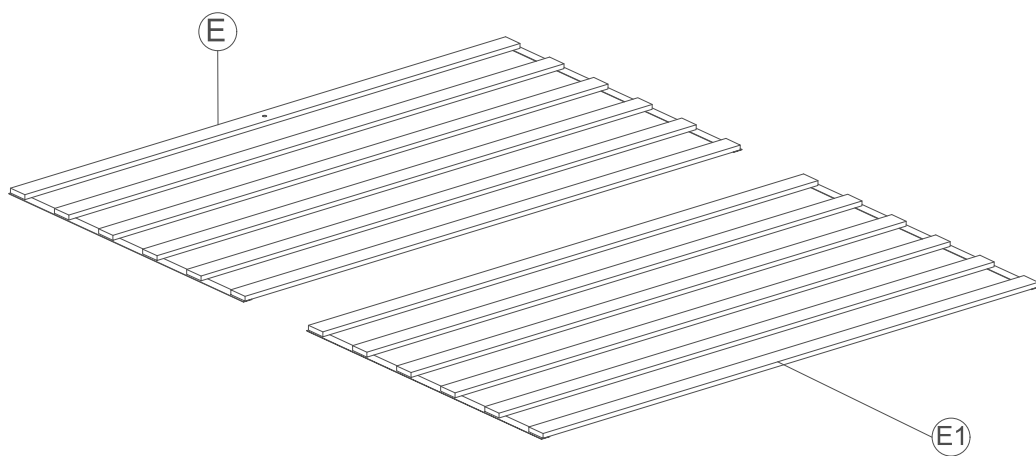
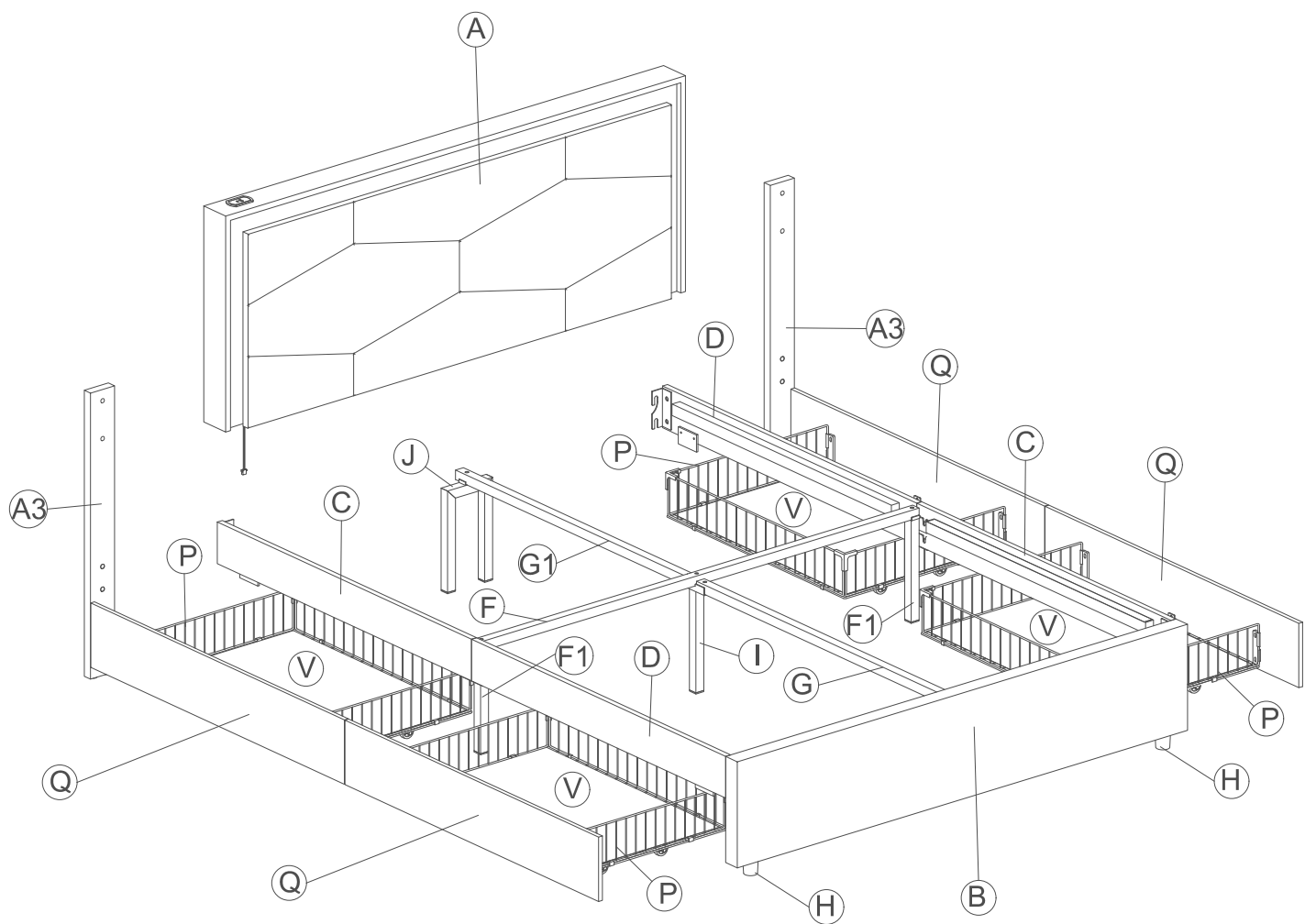

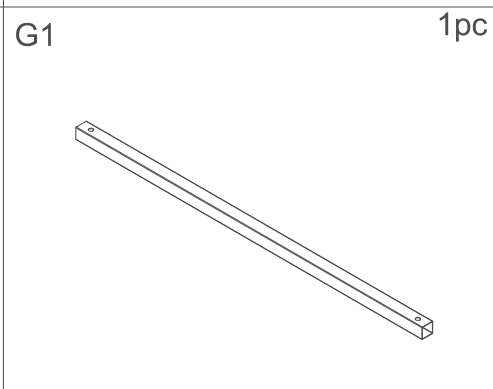
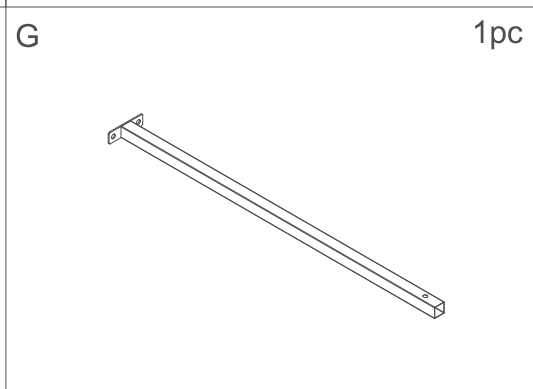
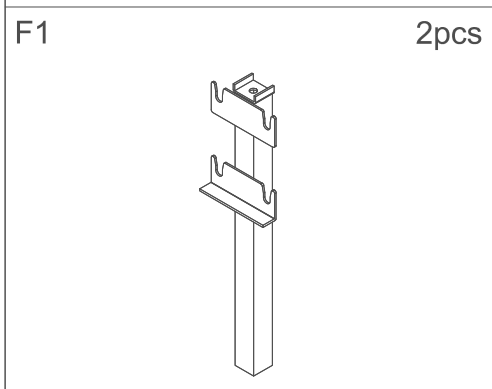
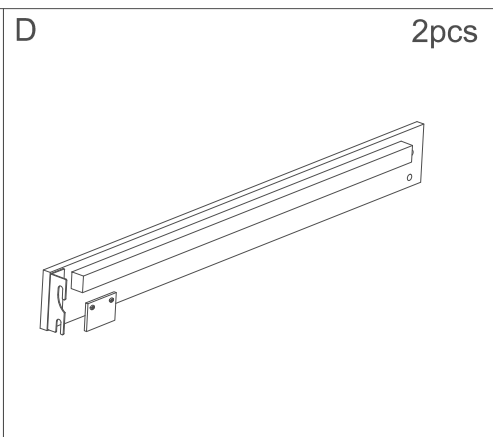
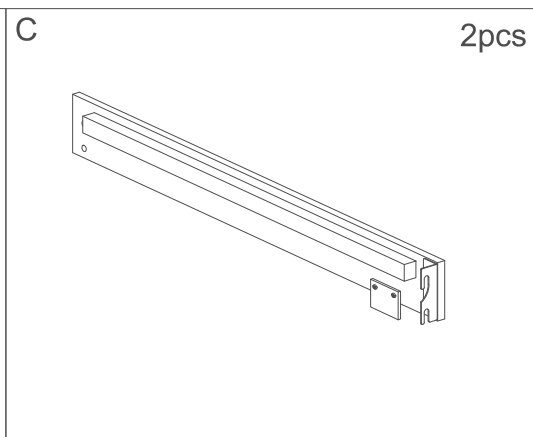
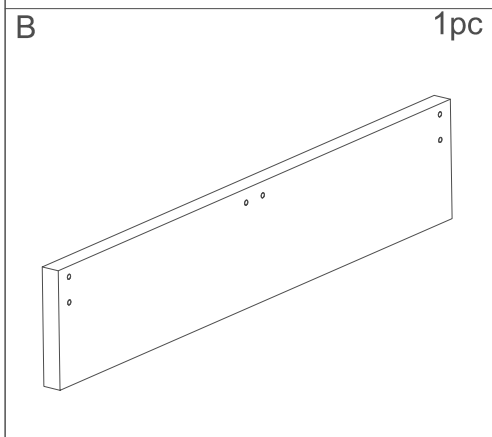
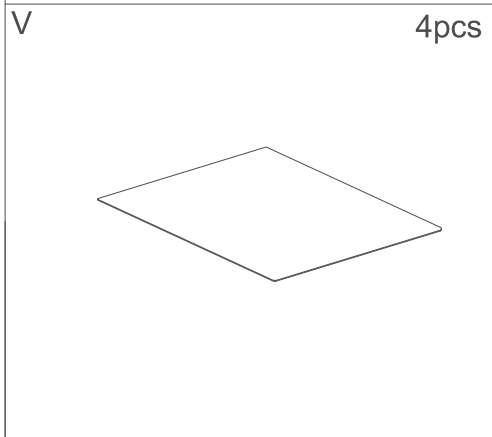
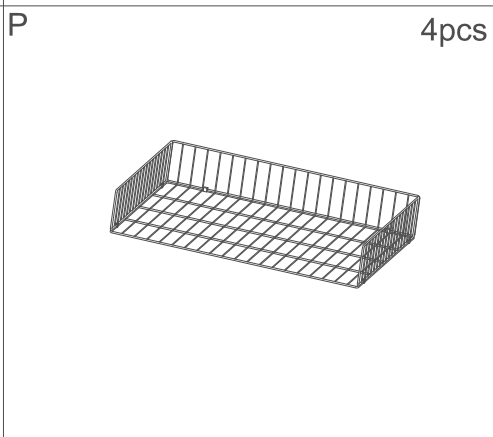
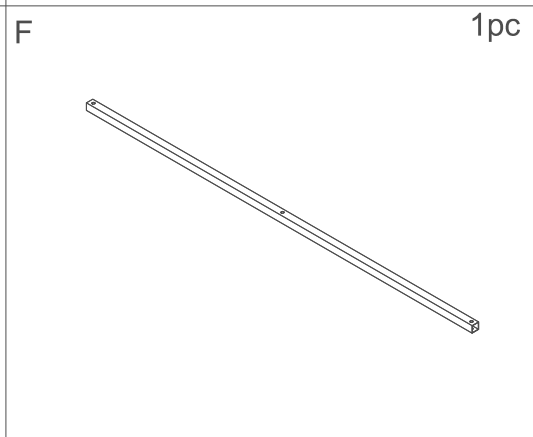
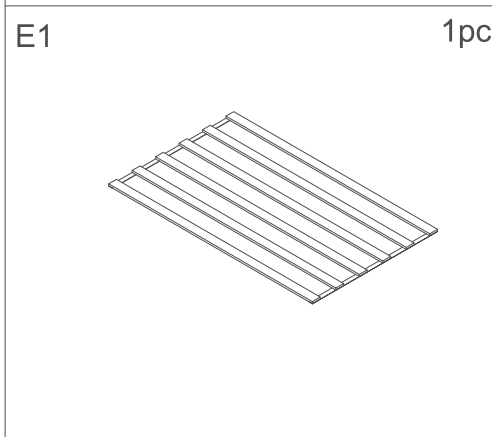
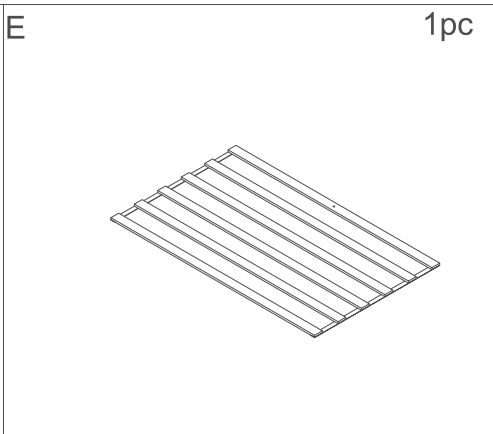
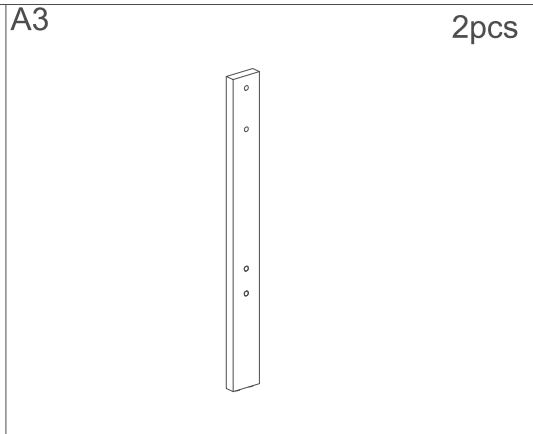
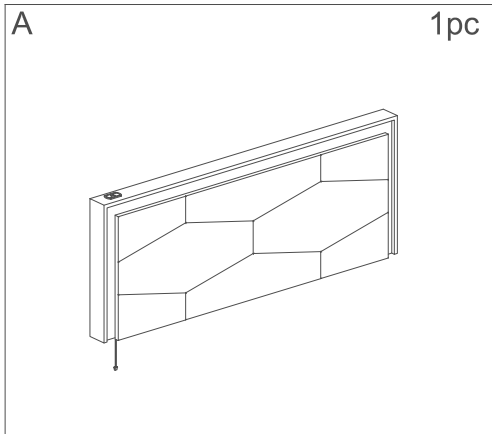
Aviso

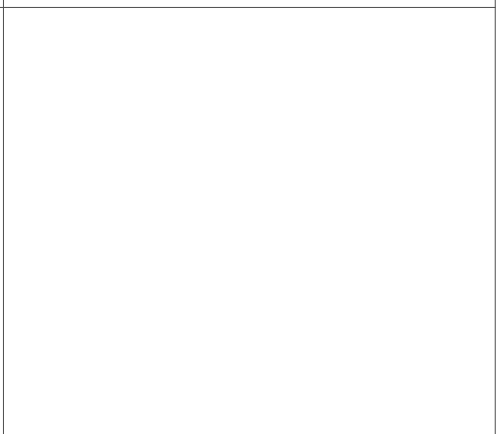
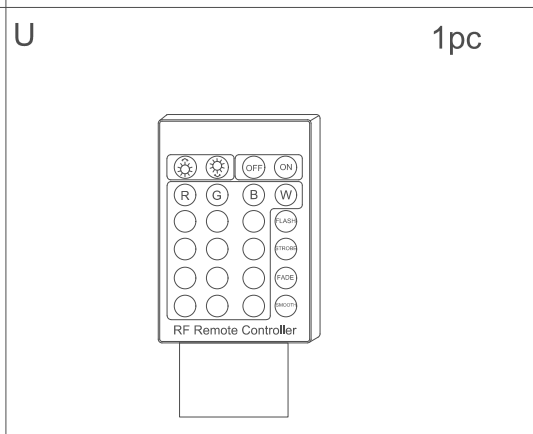
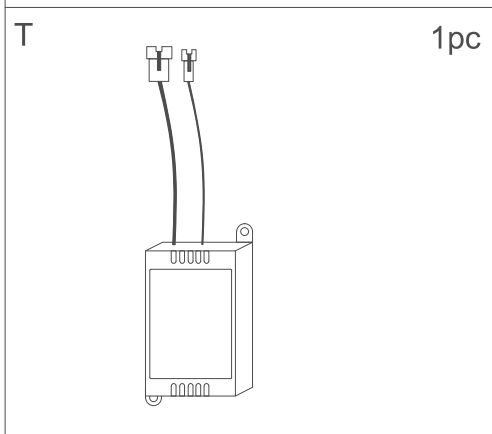
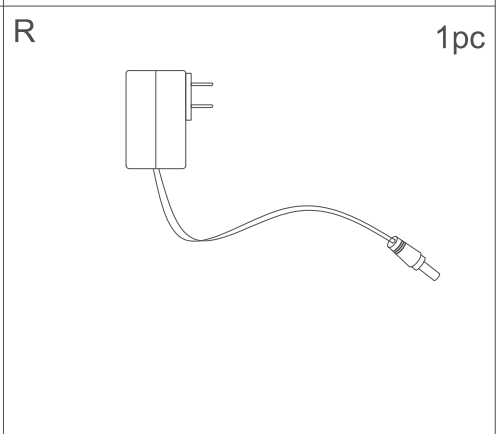
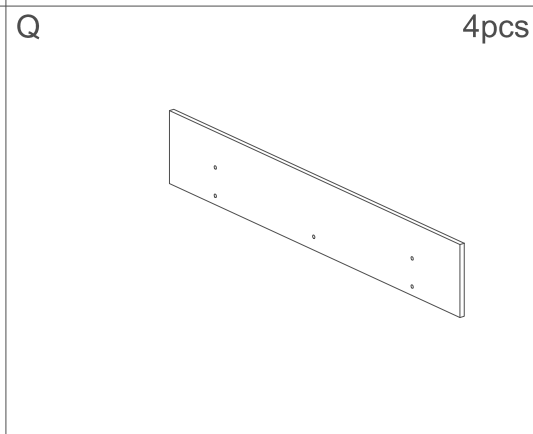
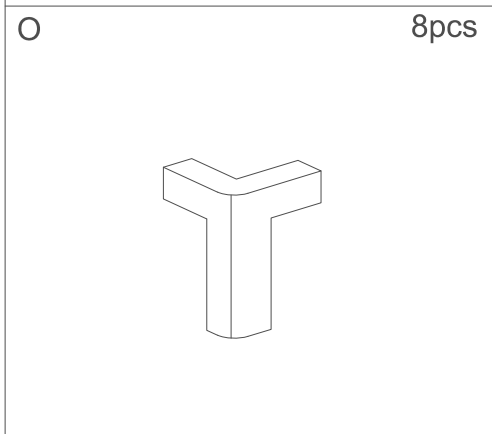
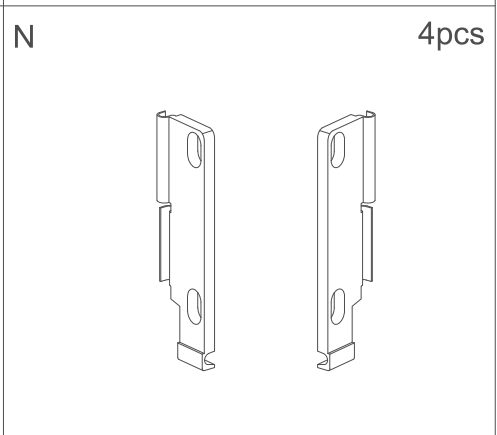
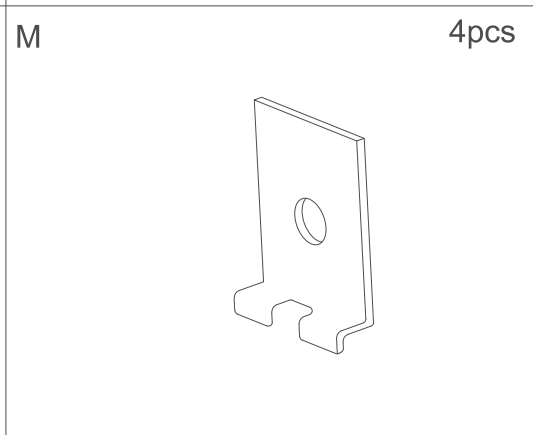
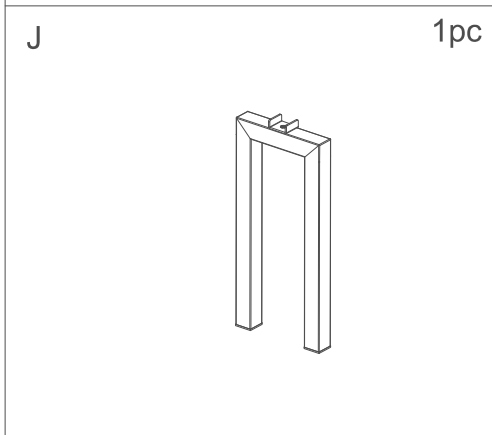
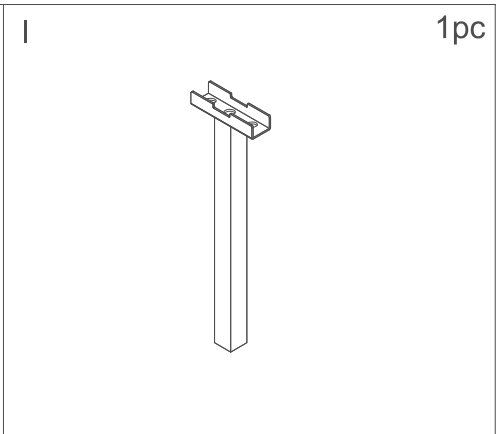
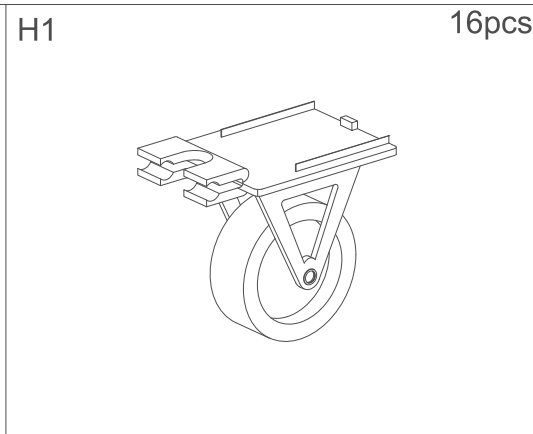
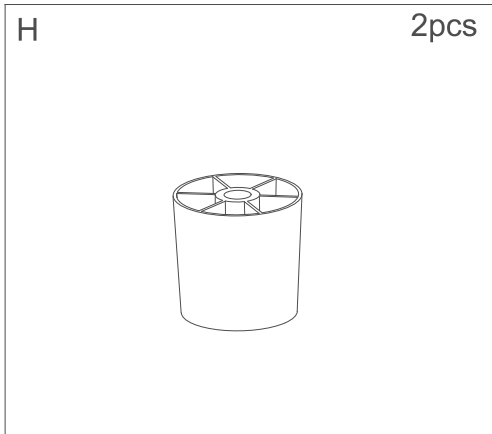
- 1 La capacidad máxima de carga del producto es de 225 kg No sobrecargar
- 2 Por seguridad, siga correctamente las instrucciones y solicite ayuda profesional si es necesario
- 3 No coloque los muebles cerca de fuentes de calor o objetos calientes para evitar el riesgo de incendio
- 4 No coloque los muebles en entornos húmedos para evitar daños en el material
- 5 Revise regularmente todas las conexiones y sujeciones para asegurarse de que estén firmes y para evitar accidentes

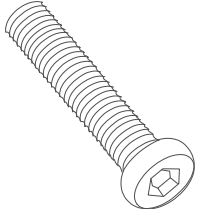

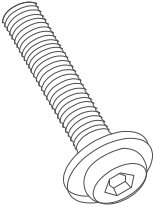
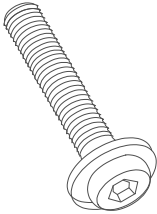
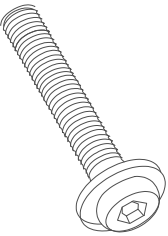



<p>1</p> <p>20pcs</p>  <p>M6*15</p>	<p>2</p> <p>2pcs</p>  <p>M6*30</p>	<p>3</p> <p>8pcs</p>  <p>M8*16</p>
<p>4</p> <p>10pcs</p>  <p>M8*25</p>	<p>5</p> <p>4pcs</p>  <p>M8*35</p>	<p>6</p> <p>4pcs</p>  <p>M8*40</p>
<p>7</p> <p>2pcs</p>  <p>M8*50</p>	<p>8</p> <p>2pcs</p>  <p>M2.6*10</p>	<p>9</p> <p>1pc</p>  <p>25*70*M4</p>
<p>10</p> <p>1pc</p>  <p>35*70*M5</p>		

1

20pcs



M6*15

2

2pcs

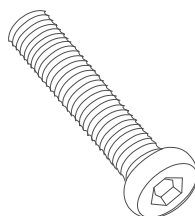

M6*30

Bitte beachten Sie, dass die Formen der Schrauben 1 und 2 ähnlich sind. Bitte installieren Sie entsprechend der Anleitung und unterscheiden Sie sie!

Please note that the shapes of screws 1 and 2 are similar. Please install according to the instructions and distinguish them!

Notez que les vis 1 et 2 ont des formes similaires. Veuillez les installer en suivant les instructions pour les séparer!

3

8pcs

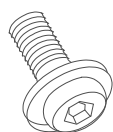

M8*16

4

10pcs

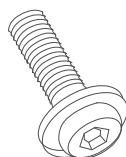

M8*25

5

4pcs

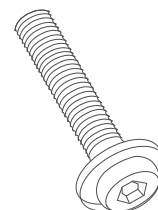

M8*35

6

4pcs

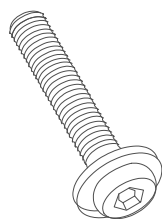

M8*40

7

2pcs

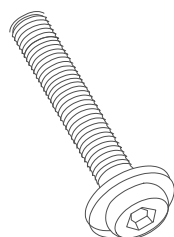

M8*50

Bitte beachten Sie, dass die Formen der Schrauben 3 und 4 und 5 und 6 und 7 ähnlich sind. Bitte installieren Sie entsprechend der Anleitung und unterscheiden Sie sie!

Please note that the shapes of screws 3 and 4 and 5 and 6 and 7 are similar. Please install according to the instructions and distinguish them!

Notez que les vis 3 et 4 et 5 et 6 et 7 ont des formes similaires. Veuillez les installer en suivant les instructions pour les séparer!

1

Vor dem Einbau die Schrauben in die Löcher stecken und festziehen, aber nicht bis 100%, 70% bis 80% anziehen reicht aus. Schließlich, nachdem alle Schrauben installiert sind, ziehen Sie alle Schrauben auf 100%. Wenn Sie auf diese Probleme stoßen, wie z. B. Fehlausrichtung der Löcher oder Unfähigkeit, bestimmte Teile zu installieren, überprüfen Sie bitte, ob die Schrauben korrekt verwendet werden und passen Sie die Dichtigkeit der Schrauben an.

Before installation, insert the screws into the holes and tighten them, but do not tighten them to 100%, 70% to 80% is sufficient. Finally, after all screws are installed, tighten all screws to 100%. If you encounter these issues, such as if the holes cannot be aligned or some parts cannot be installed, please check if the screws are used correctly and adjust the tightness of the screws.

Insérer la vis dans le trou avant la fin de l'assemblage, serrer la vis, mais ne pas serrer à 100%, 70% ~ 80% est correct. Enfin, une fois que toutes les vis sont bien serrées, toutes les vis sont serrées à 100%. Si vous rencontrez ces problèmes, par exemple si les trous ne sont pas alignés ou si certaines pièces ne peuvent pas être montées, vérifiez que les vis sont utilisées correctement et ajustez leur serrage.

2

Das Kopfteil (A) kann nach oben und unten verstellt werden, indem die Position mit Schrauben Nr. 3 fixiert wird.
The headboard (A) can be adjusted up and down by fixing the position with NO.3 screws.
La tête de lit (A) peut être réglée vers le haut et vers le bas en fixant la position à l'aide des vis NO.3.

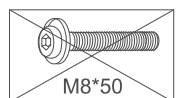
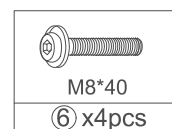
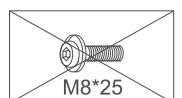
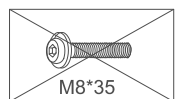
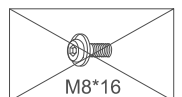
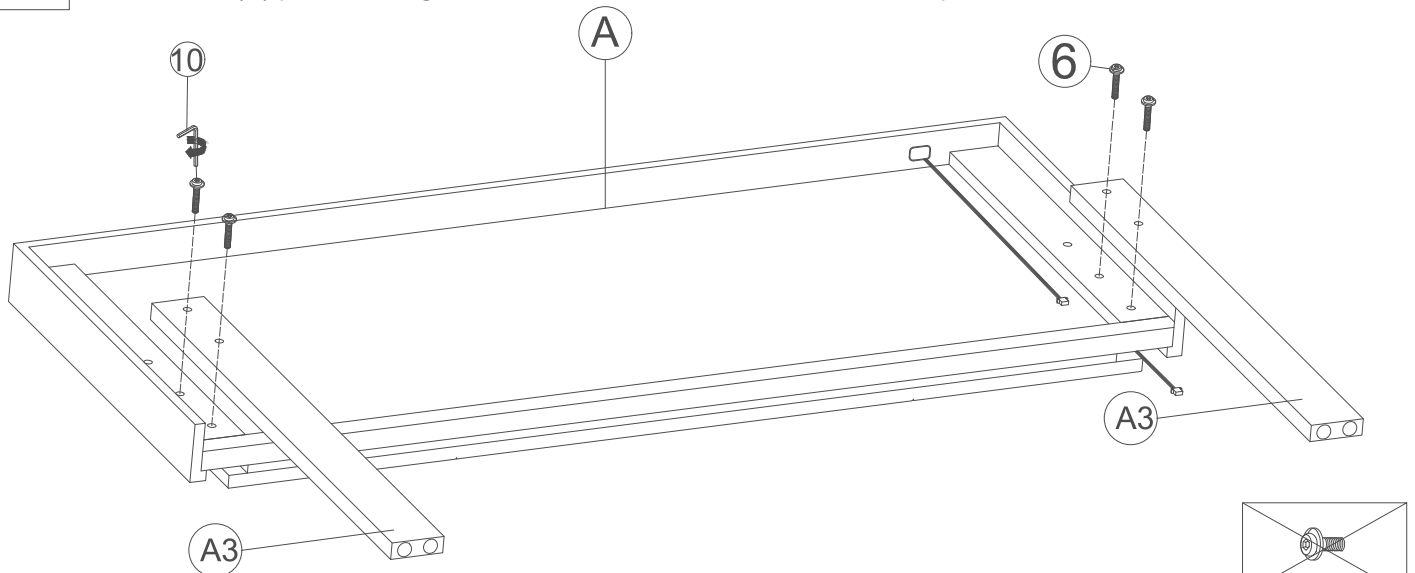

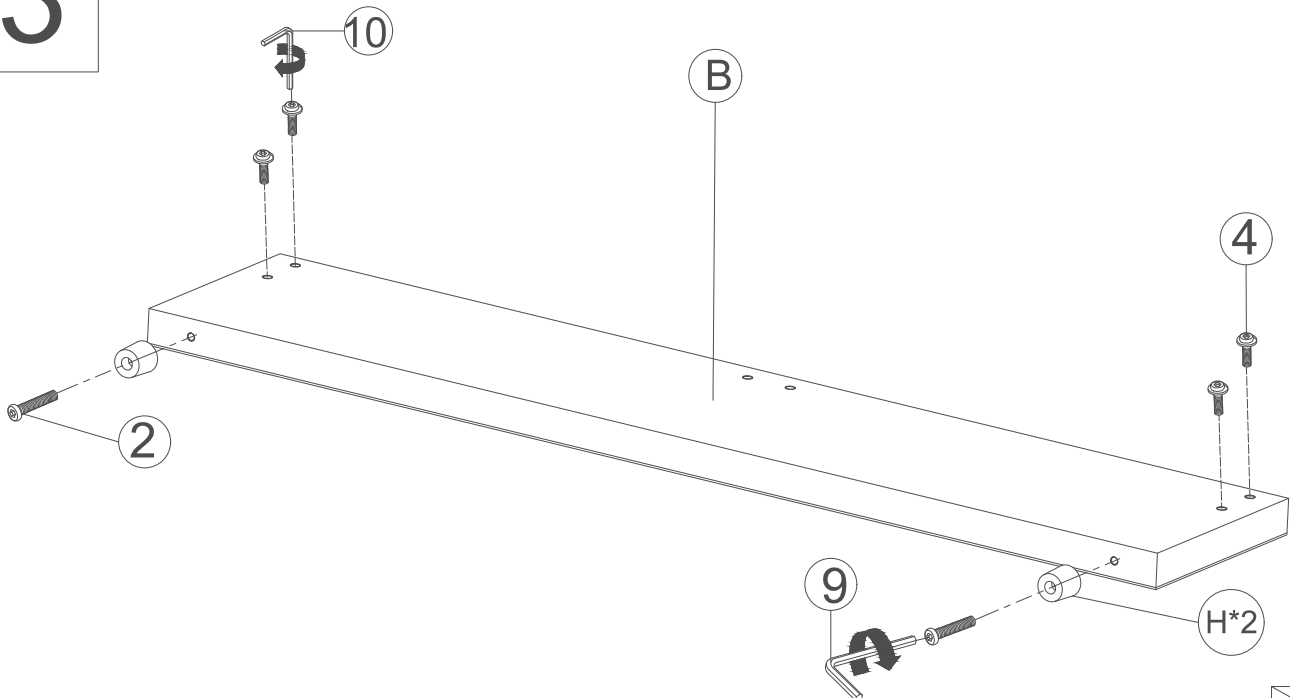

3





M8*25
④ x4pcs



M6*15

M8*16



M8*40



M6*30
② x2pcs

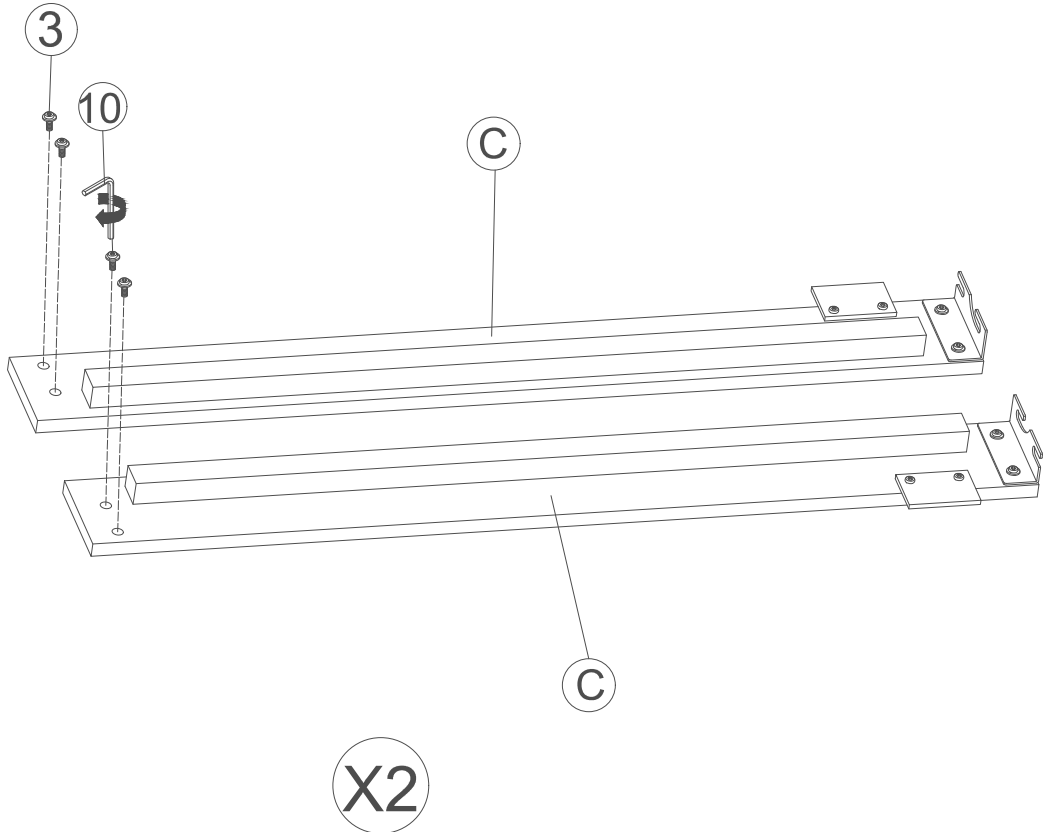

M8*35



M8*50

4





M8*40



M8*35

M8*25

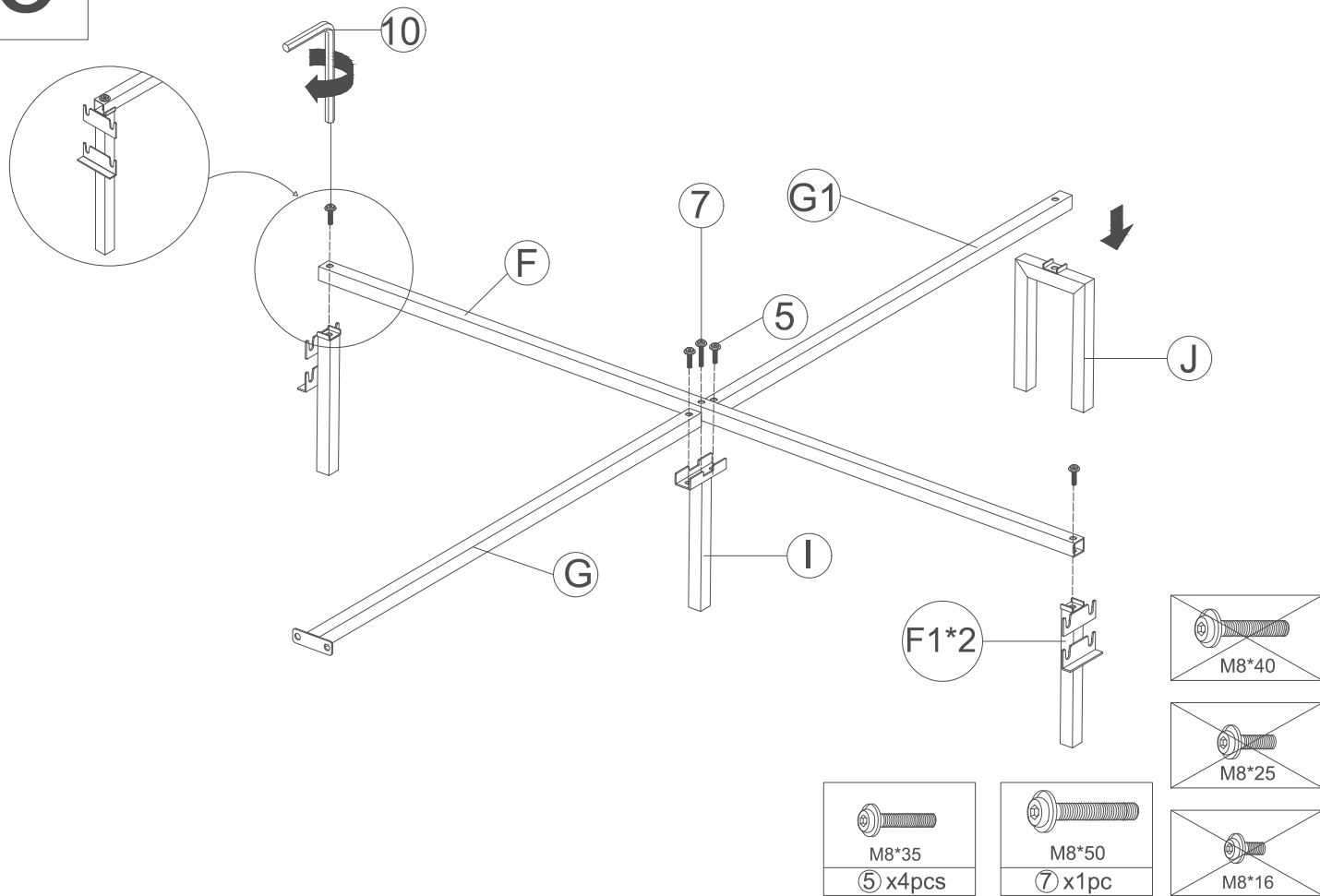

M8*16
③ x8pcs

M8*50

5

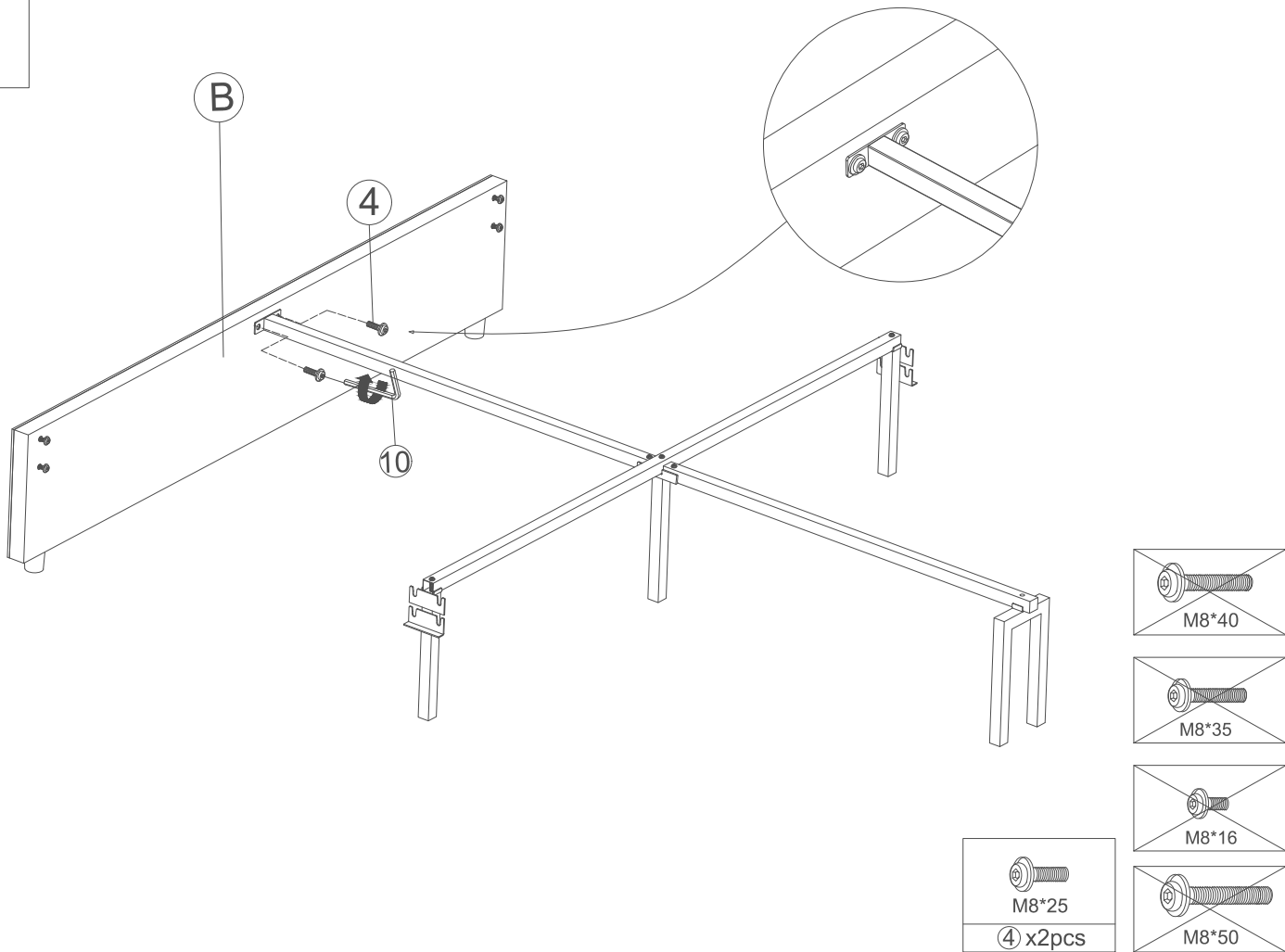

6



7

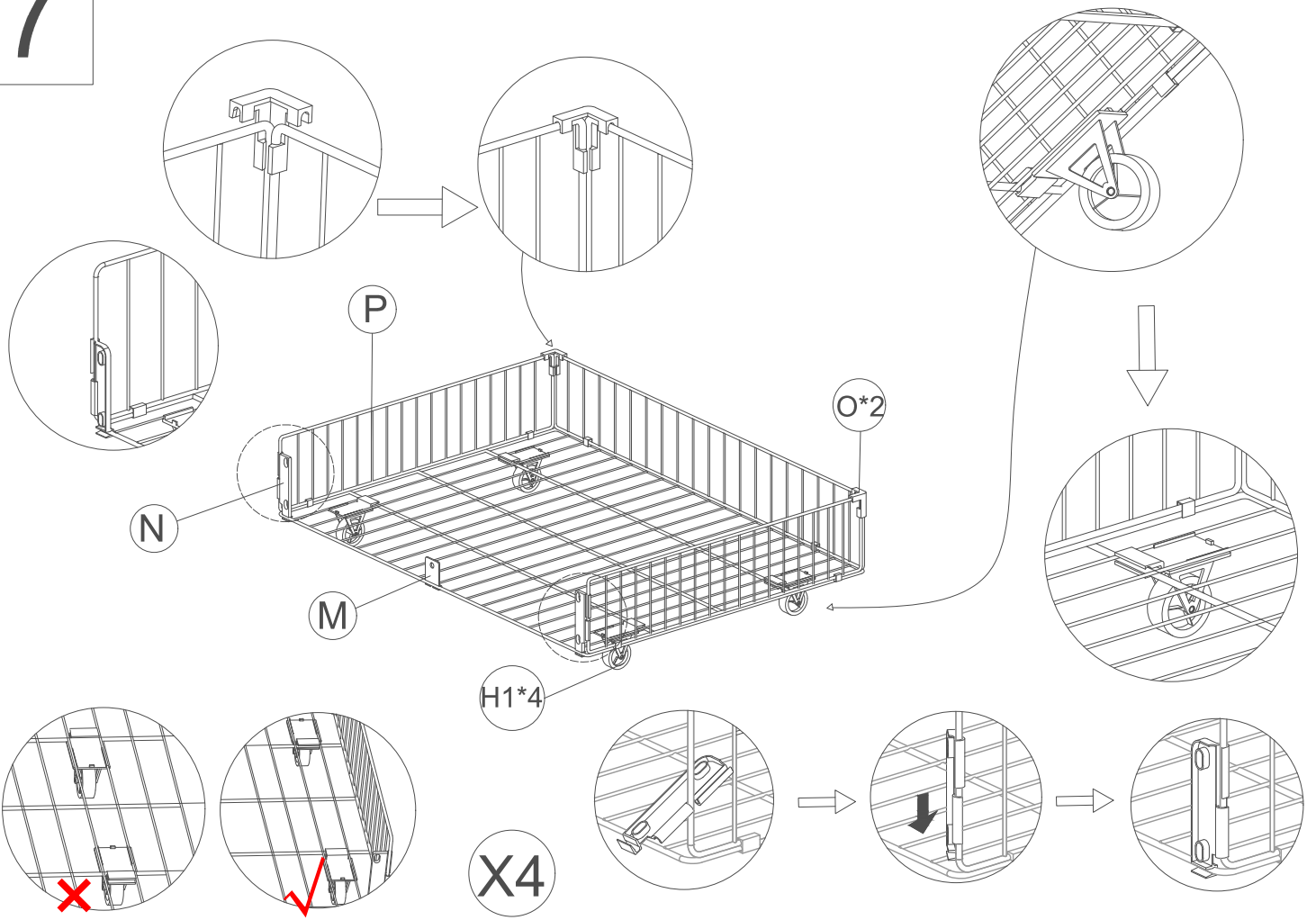

8

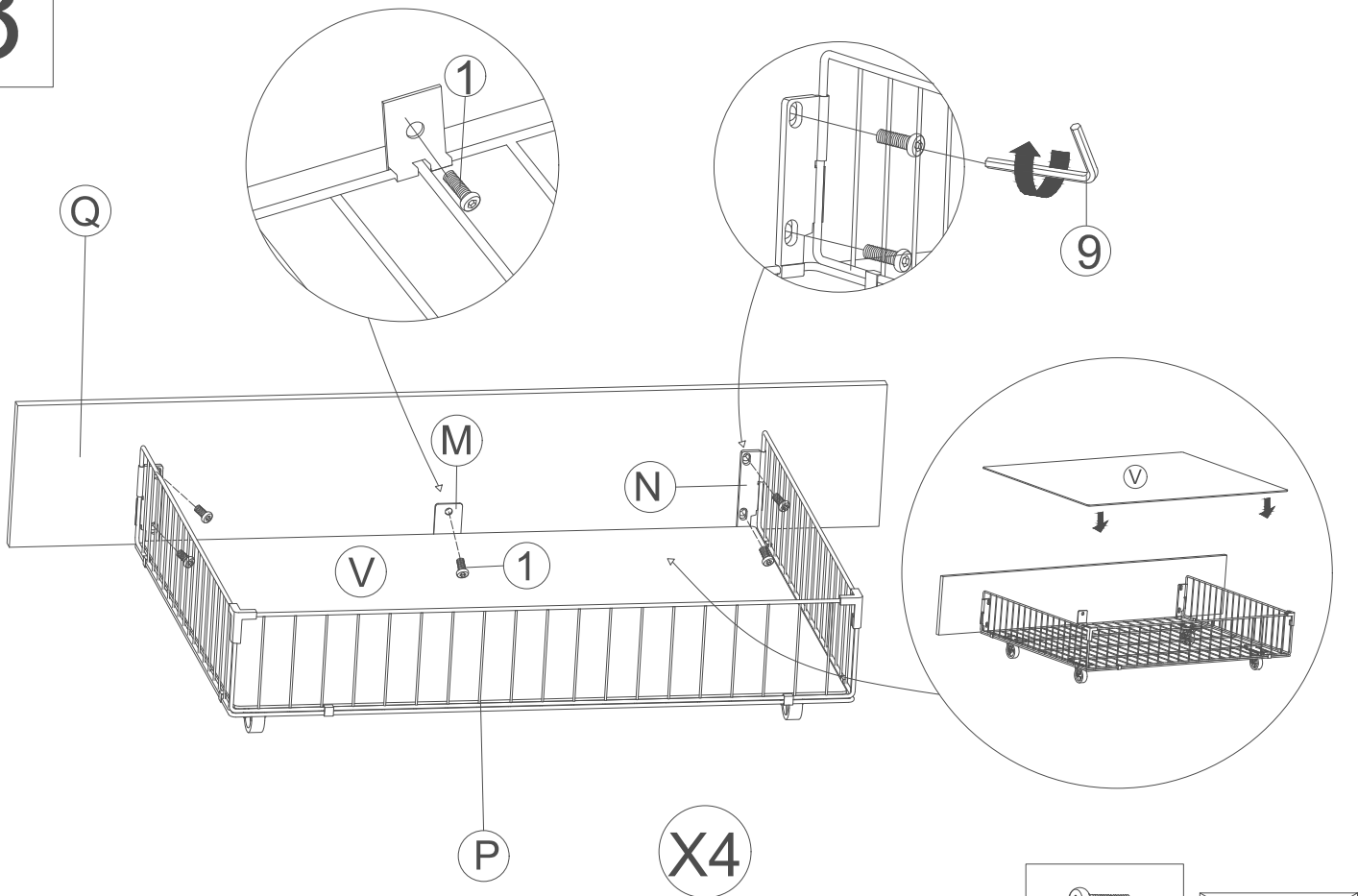

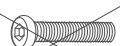
	
M6*15	M6*30
① x20pcs	

9

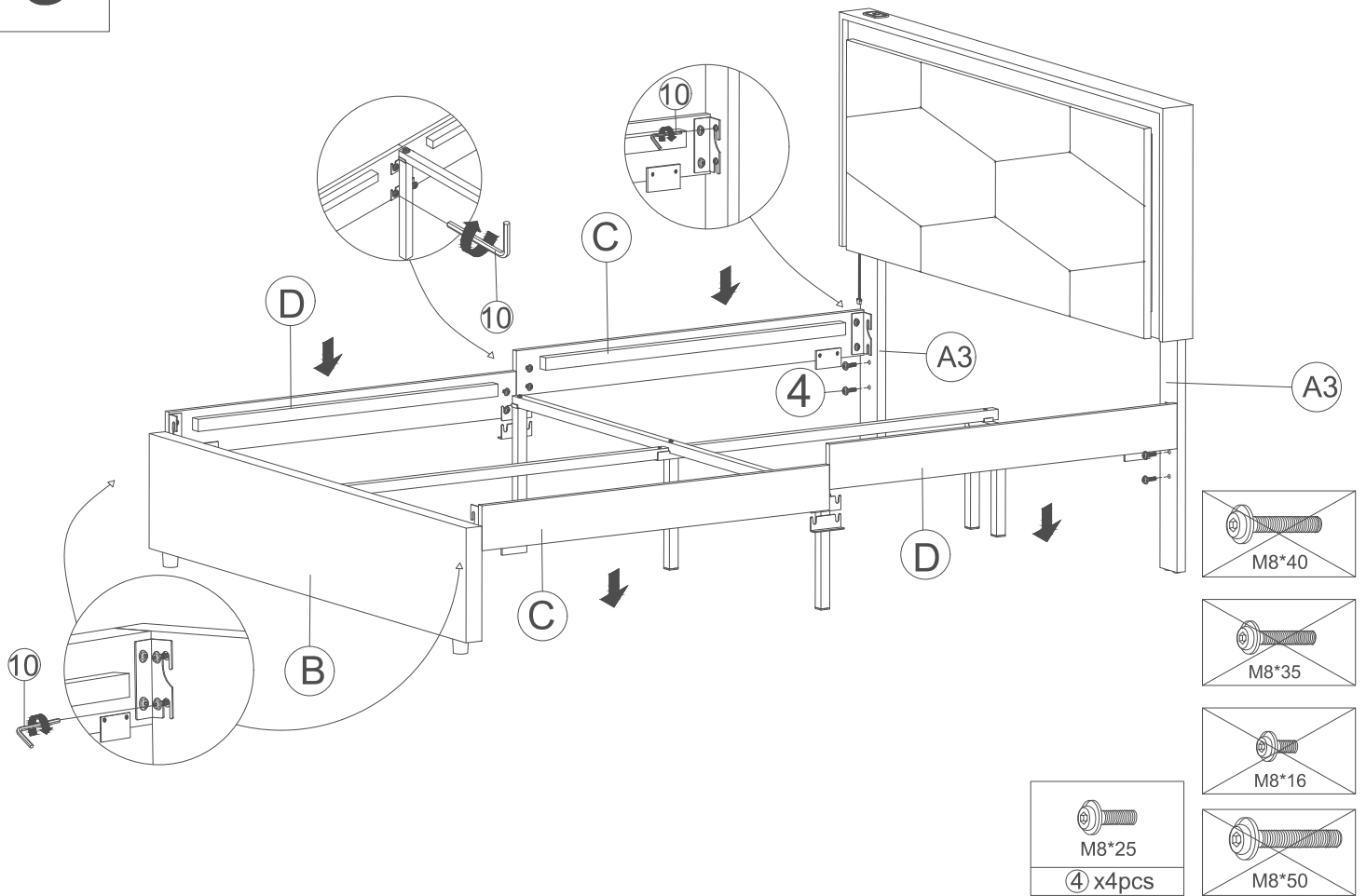

10

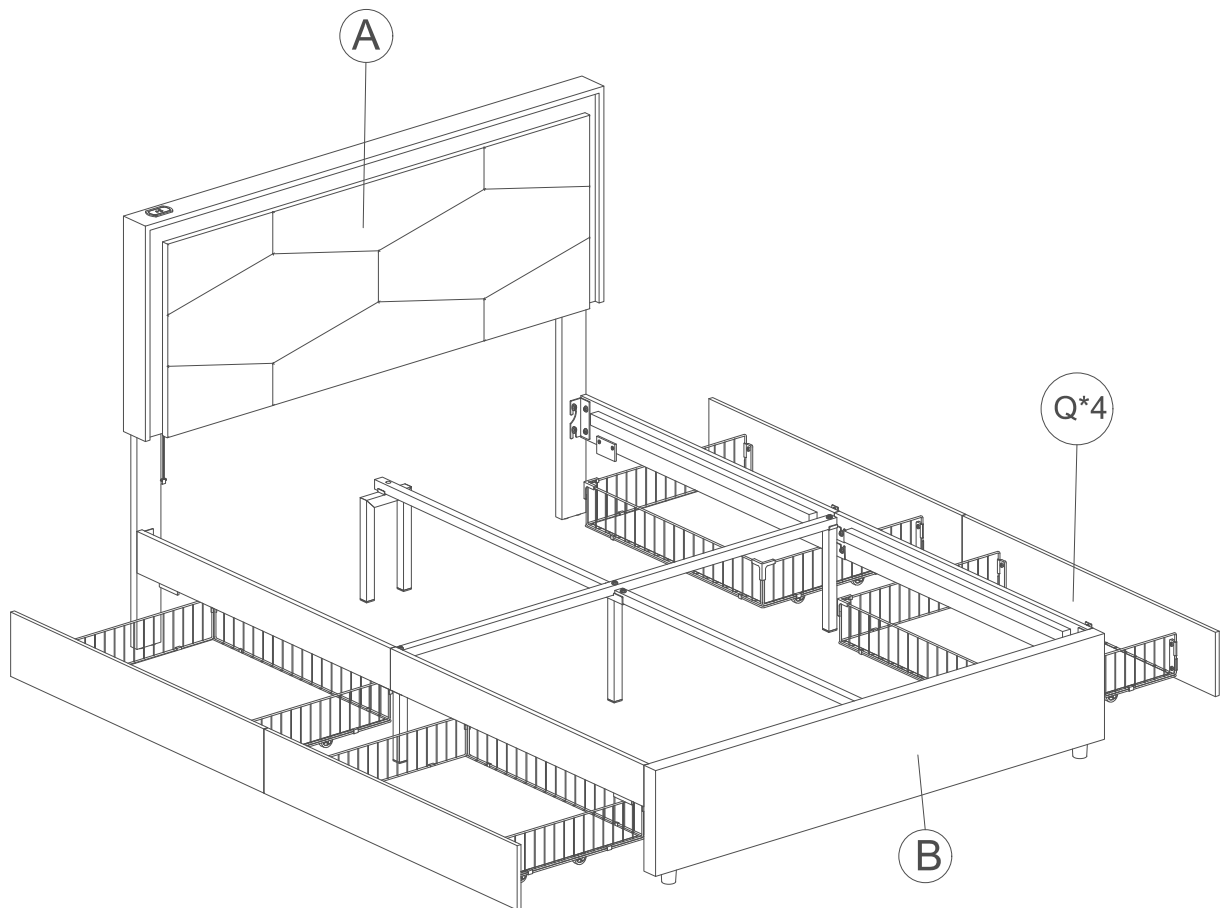

11

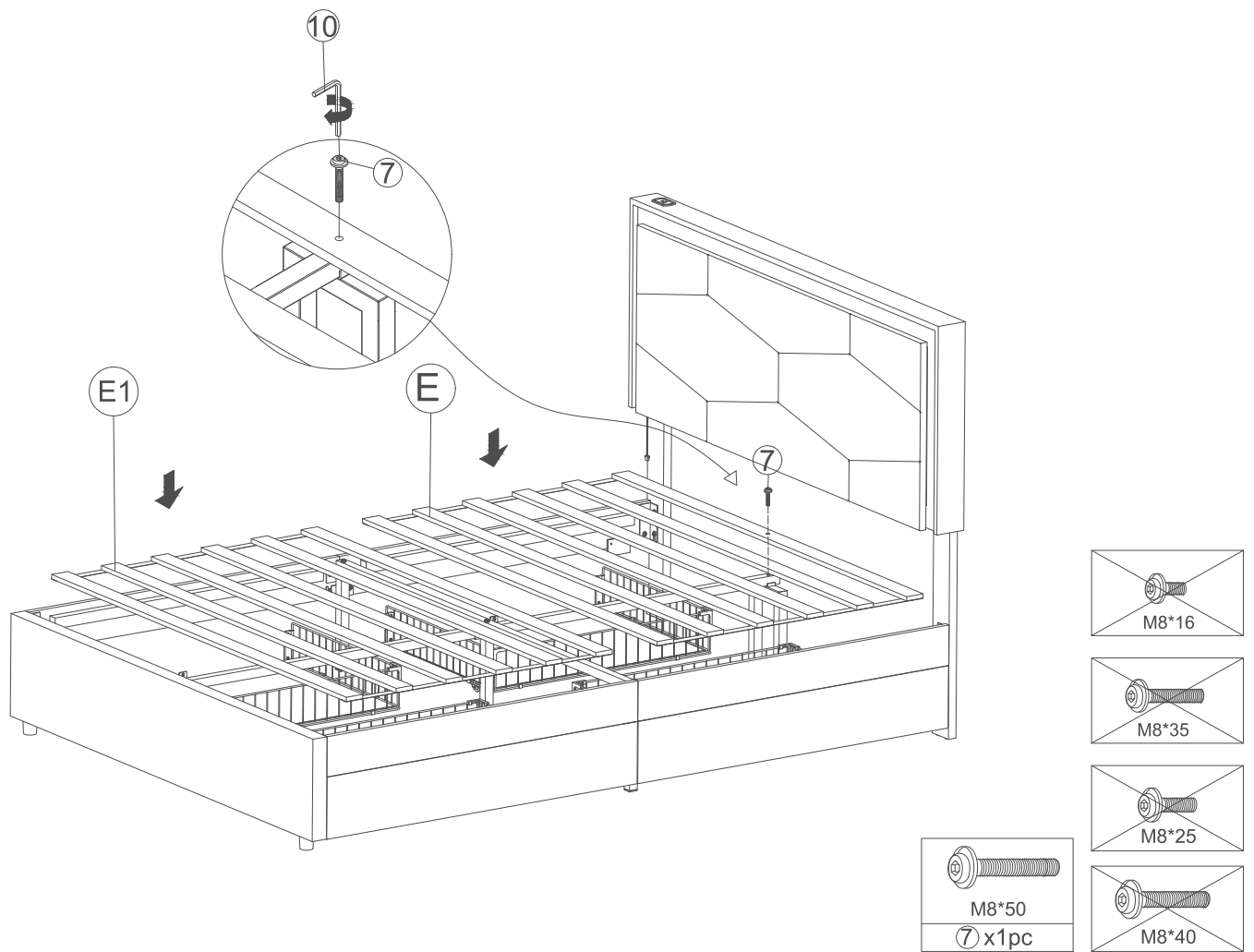

12

