

<b>DE</b>	Gebrauchsanleitung / Montageanleitung	2
<b>FR</b>	Mode d'emploi / Instructions de montage	2
<b>EN</b>	Instructions for use / Assembly instructions	3
<b>IT</b>	Istruzioni per l'uso / Istruzioni per Installazione	3
<b>ES</b>	Modo de empleo / Instrucciones de montaje	4
<b>NL</b>	Gebruiksaanwijzing / Handleiding	4
<b>DK</b>	Brugsanvisning / Monteringsvejledning	5
<b>PT</b>	Instruções para uso / Manual de Instalação	5
<b>PL</b>	Instrukcja obsługi / Instrukcja montażu	6
<b>CS</b>	Návod k použití / Montážní návod	6
<b>SK</b>	Návod na použitie / Montážny návod	7
<b>ZH</b>	用户手册 / 组装说明	7
<b>RU</b>	Руководство пользователя / Инструкция по монтажу	8
<b>FI</b>	Käyttöohje / Asennusohje	8
<b>SV</b>	Bruksanvisning / Monteringsanvisning	9
<b>LT</b>	Vartotojo instrukcija / Montavimo instrukcijos	9
<b>HR</b>	Upute za uporabu / Uputstva za instalaciju	10
<b>RO</b>	Manual de utilizare / Instrucțiuni de montare	10
<b>EL</b>	Οδηγίες χρήσης / Οδηγία συναρμολόγησης	11
<b>SL</b>	Navodilo za uporabo / Navodila za montažo	11
<b>ET</b>	Kasutusjuhend / Paigaldusjuhend	12
<b>LV</b>	Lietošanas pamācība / Montāžas instrukcija	12
<b>SR</b>	Uputstvo za upotrebu / Uputstvo za montažu	13
<b>NO</b>	Bruksanvisning / Montasjeveiledning	13
<b>BG</b>	Инструкция за употреба / Ръководство за монтаж	14
<b>JP</b>	取扱説明書 / 施工説明書	14
<b>SQ</b>	Udhëzuesi i përdorimit / Udhëzime rreth montimit	15
<b>AR</b>	دليل الاستخدام / تعليمات التجميع	15
<b>TR</b>	Kullanım kılavuzu / Montaj kılavuzu	16
<b>HU</b>	Használati útmutató / Szerelési útmutató	17
<b>HE</b>	הוראות שימוש / הוראות הרכבה	17

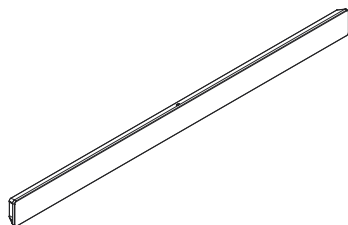

**WallStoris**  
27902XXX / 27904XXX

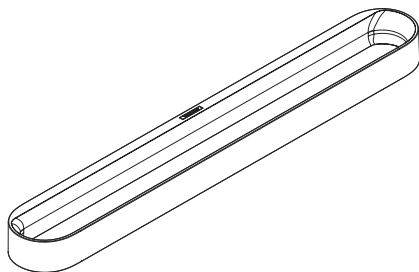

**WallStoris**  
27926XXX

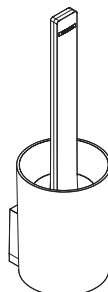

**WallStoris**  
27927XXX

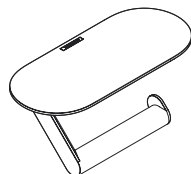

**WallStoris**  
27928XXX



## Sicherheitshinweise

- ⚠ Bei der Montage müssen zur Vermeidung von Quetsch- und Schnittverletzungen Handschuhe getragen werden.
- ⚠ Das Produkt darf nicht als Haltegriff benutzt werden. Es muss ein separater Haltegriff montiert werden.
- ⚠ Darf nicht in Hände von Kindern gelangen.

## Montagehinweise

- Vor der Montage muss das Produkt auf Transportschäden untersucht werden. Nach dem Einbau werden keine Transport- oder Oberflächenschäden anerkannt.
- Die Haftflächen müssen tragfähig, frei von Trennmitteln, sauber, trocken, wachs- und fettfrei sein. In den meisten Fällen ist es am besten, die Fläche nur mit einem sauberen und trockenen Tuch fest abzureiben. Keine konventionellen, trennmittelhaltigen Reiniger verwenden. Bei Bedarf reine Alkohol-Reiniger und bei gewachsenen Natursteinen wachslösende Reiniger verwenden. Vor Verdunstung mit einem sauberen trockenen Tuch nachreiben.
- Die ordnungsgemäße Befestigung und der feste Sitz der montierten Produkte ist in periodischen Abständen (jährlich) zu überprüfen.

## Symbolerklärung

 Kein essigsäurehaltiges Silikon verwenden!

 **Maße** (siehe Seite 29)

 **Montagebeispiele** (siehe Seite 18)

 **Demontage** (siehe Seite 28)

 **Serviceteile** (siehe Seite 30)

XXX = Farbcodierung

670 = Mattschwarz

700 = Mattweiß

 **Sonderzubehör**  
(nicht im Lieferumfang enthalten)

 • Befestigungsteile #96179000  
(siehe Seite 30)

 • Befestigungsteile #94268000  
(siehe Seite 30)

 **Reinigung** (siehe Seite 31)

## Consignes de sécurité

- ⚠ Lors du montage, porter des gants de protection pour éviter toute blessure par écrasement ou coupure.
- ⚠ Le produit ne doit pas servir de poignée. Monter pour cela une poignée séparée.
- ⚠ Tenir hors de portée des enfants.

## Instructions pour le montage

- Avant son montage, s'assurer que le produit n'a subi aucun dommage pendant le transport. Après le montage, tout dommage de transport ou de surface ne pourra pas être reconnu.
- Les surfaces à coller doivent être libres de tout agent séparateur, propre, sèches, et sans cire ou graisse. Dans la plupart des cas, le mieux est de frotter les surfaces avec un chiffon sec et propre. N'utiliser aucun nettoyeur conventionnel contenant des séparateurs. En cas de besoin, utiliser un nettoyeur hydroalcoolique et un nettoyeur dissolvant la cire pour la pierre naturelle cirée. Avant la vaporisation, frotter avec un chiffon propre et sec.
- Vérifier à intervalles réguliers (une fois par an) la fixation correcte et la bonne assise des produits montés

## Description du symbole

 Ne pas utiliser de silicone contenant de l'acide acétique!

 **Dimensions** (voir pages 29)

 **Exemples de montage**  
(voir pages 18)

 **Démontage** (voir pages 28)

 **Pièces détachées** (voir pages 30)

XXX = Couleurs

670 = Matt Black

700 = Matt White

 **Accessoires en option**  
(ne fait pas partie de la fourniture)

 • set de fixation #96179000 (voir pages 30)

 • set de fixation #94268000 (voir pages 30)

 **Nettoyage** (voir pages 31)

**Montage**  
(siehe Seite 19) 

**Montage**  
(voir pages 19) 

**Safety Notes**

- ⚠ Gloves should be worn during installation to prevent crushing and cutting injuries.
- ⚠ The product may not be used as a holding handle. A separate handle must be installed.
- ⚠ Keep out of the reach of children!

**Installation Instructions**

- Prior to installation, inspect the product for transport damages. After it has been installed, no transport or surface damage will be honoured.
- The bonding surfaces must be clean, dry, wax and grease-free, able to bear weight and free of release agents. In most case it is best to wipe down the surface with a clean dry cloth. Do not use any conventional cleansers containing releaseagents. If necessary, use an alcohol cleaner or in the case of waxy natural stone, use a wax-removing cleaner. Rub this off with a clean, dry cloth before it evaporates.
- Check the proper attachment and tight seating of the installed products periodically (annually).

**Symbol description**

Do not use silicone containing acetic acid!



**Dimensions** (see page 29)



**Installation example** (see page 18)



**Dismounting** (see page 28)



**Spare parts** (see page 30)

XXX = Colors

670 = Matt Black

700 = Matt White



**Special accessories**  
(order as an extra)



• mounting set #96179000 (see page 30)

• mounting set #94268000 (see page 30)



**Cleaning** (see page 31)

**Indicazioni sulla sicurezza**

- ⚠ Durante il montaggio, per evitare ferite da schiacciamento e da taglio bisogna indossare guanti protettivi.
- ⚠ Il prodotto non deve essere utilizzato come maniglia, questa deve essere montata separatamente.
- ⚠ tenere fuori dalla portata dei bambini.

**Istruzioni per il montaggio**

- Prima del montaggio è necessario controllare che non ci siano stati danni durante il trasporto. Una volta eseguito il montaggio, non verranno riconosciuti eventuali danni di trasporto o delle superfici.
- La superficie deve essere appropriata per il fissaggio di oggetti pesanti, deve essere ben pulita, asciutta e priva di cere o grassi. Nella maggioranza dei casi è la miglior cosa strofinare con vigore la superficie tramite un panno pulito e asciutto. Non utilizzare prodotti di pulizia convenzionali con agenti tensioattivi (come detersivi). In caso di necessità utilizzare un prodotto per la pulizia contenente alcool e per le pietre naturali cerate un prodotto decerante. Prima dell'evaporazione strofinare con un panno pulito e asciutto.
- Il fissaggio a regola d'arte e la sede fissa dei prodotti montati va controllato a intervallo periodico (annualmente).

**Descrizione simbolo**

Non utilizzare silicone contenente acido acetico!



**Ingombri** (vedi pagg. 29)



**Esempio di installazione**  
(vedi pagg. 18)



**Smontaggio** (vedi pagg. 28)



**Parti di ricambio** (vedi pagg. 30)

XXX = Trattamento

670 = Matt Black

700 = Matt White



**Accessori speciali**  
(non contenuto nel volume di fornitura)



• set di fissaggio #96179000 (vedi pagg. 30)

• set di fissaggio #94268000 (vedi pagg. 30)



**Pulitura** (vedi pagg. 31)

**Assembly**  
(see page 19)



**Montaggio**  
(vedi pagg. 19)





## Indicaciones de seguridad

- ⚠ Durante el montaje deben utilizarse guantes para evitar heridas por aplastamiento o corte.
- ⚠ El producto no debe ser utilizado como un elemento de sujeción. Debe montarse un elemento de sujeción separado.
- ⚠ Mantener fuera del alcance de los niños.

## Indicaciones para el montaje

- Antes del montaje se debe examinarse el producto contra daños de transporte. Después de la instalación no se reconoce ningún daño de transporte o de superficie.
- La superficie en donde se fijará el objeto debe ser capaz de soportar el peso de éste. También deberá estar limpio, seco y libre de grasa o cera. Generalmente, lo mejor es limpiar la superficie con un paño limpio y seco y sin uso de detergentes que contengan deslizantes. Si es necesario, utilizar un limpiador a base de alcohol y para piedras enceradas un removedor de cera. Antes que se seque, frotar con un paño limpio y seco.
- Debe comprobarse en intervalos periódicos (anualmente) que los productos montados estén bien fijados y asentados.

## Descripción de símbolos

 No utilizar silicona que contiene ácido acético!

 **Dimensiones** (ver página 29)

 **Ejemplos de montaje** (ver página 18)

 **Despiece** (ver página 28)

 **Repuestos** (ver página 30)

XXX = Acabados  
670 = Matt Black  
700 = Matt White

 **Opcional** (no incluido en el suministro)

- Set de fijación #96179000 (ver página 30)
- Set de fijación #94268000 (ver página 30)

 **Limpiar** (ver página 31)

## Veiligheidsinstructies

- ⚠ Bij de montage moeten ter voorkoming van knel- en snijwonden handschoenen worden gedragen.
- ⚠ Het product mag niet als handgreep worden gebruikt. Er moet een aparte handgreep gemonteerd worden.
- ⚠ Mag niet in handen van kinderen terechtkomen.

## Montage-instructies

- Vóór de montage moet het product gecontroleerd worden op transportschade. Na de inbouw wordt geen transport- of oppervlakeschade meer aanvaard.
- De hechtingsvlakken moeten draagkrachtig, vrij van scheidingsmiddelen, proper, droog, wax- en vetvrij zijn. In de meeste gevallen wordt het oppervlak best gewoon met een propere en droge doek schoon te wrijven. Gebruik geen conventionele, scheidingsmiddelhoudende reinigingsmiddelen. Gebruik indien nodig zuivere alcoholreiniger en bij gewaxte natuursteen waxoplossende reinigingsmiddelen. Wrijf vóór de verdamping op met een propere en droge doek.
- De reglementaire bevestiging en de vaste zitting van de gemonteerde producten moet regelmatig (jaarlijks) gecontroleerd worden.

## Symboolbeschrijving

 Gebruik geen zuurhoudende silicone!

 **Maten** (zie blz. 29)

 **Montagevoorbeelden** (zie blz. 18)

 **Demontage** (zie blz. 28)

 **Service onderdelen** (zie blz. 30)

XXX = Kleuren  
670 = Matt Black  
700 = Matt White

 **Toebehoren**  
(behoort niet tot het leveringspakket)

 • bevestigingsmateriaal #96179000  
(zie blz. 30)

 • bevestigingsmateriaal #94268000  
(zie blz. 30)

 **Reinigen** (zie blz. 31)

**Montaje**  
(ver página 19) 

**Montage**  
(zie blz. 19) 





## Sikkerhedsanvisninger

- ⚠ Ved monteringen skal der bruges handsker for at undgå kvæstelser og snitsår.
- ⚠ Produktet må ikke bruges som håndtag. Der skal monteres et separat håndtag.
- ⚠ Opbevares utilgængeligt for børn.

## Monteringsanvisninger

- Før monteringen skal produktet kontrolleres for transportskader. Efter monteringen godkendes transportskader eller skader på overfladen ikke længere.
- Overfladen skal være holdbar, fri for opløsningsmidler, ren, tør, voks og fedtfri. Dette opnåes ved at anvende en alkoholbaseret rengøringsvæske. F.eks. Kemisk ren acetone eller lign. Anvend aldrig konventionelle, eller olieholdige rengøringsmidler. Ved montage på voksbehandlede natursten skal et voksopløsende rengøringsmiddel anvendes.
- Den korrekte montering og position af monterede produkter skal kontrolleres i regelmæssige afstande (årligt).

## Symbolbeskrivelse

 Der må ikke benyttes eddikesyreholdig silikone!

 **Målene** (se s. 29)

 **Monteringseksempler** (se s. 18)

 **Afmontere** (se s. 28)

 **Reservevedle** (se s. 30)

XXX = Overflade  
670 = Matt Black  
700 = Matt White

 **Specialtilbehør**  
(ikke med i leveringsomfang)

- Befæstigelsessæt #96179000 (se s. 30)
- Befæstigelsessæt #94268000 (se s. 30)

 **Rengøring** (se s. 31)

## Montering

(se s. 19) 

## Avisos de segurança

- ⚠ Durante a montagem devem ser utilizadas luvas de protecção, de modo a evitar ferimentos resultantes de entalamentos e de cortes.
- ⚠ O produto não pode ser utilizado como pega de apoio. Tem que ser montada uma pega separada.
- ⚠ Manter fora do alcance das crianças.

## Avisos de montagem

- Antes da montagem deve-se controlar o produto relativamente a danos de transporte. Após a montagem não são aceites quaisquer danos de transporte ou de superfície.
- As superfícies adesivas devem ser apropriadas para a fixação, estar livres de antiaglomerantes, cera, gordura e devem estar limpas e secas. Na maior parte dos casos, é aconselhável limpar a superfície apenas com um pano limpo e seco. Não utilizar nenhum produto de limpeza convencional, com agentes tensoativos (detergentes). Se necessário, utilizar um produto de limpeza à base de álcool puro (ver "Conselhos para profissionais") e, para as pedras naturais enceradas, utilizar um produto de limpeza com características decapantes. Antes da evaporação, esfregar com um pano limpo e seco.
- A fixação e encaixe correctos dos produtos montados devem ser verificados periodicamente (anualmente).

## Descrição do símbolo

 Não utilizar silicone que contenha ácido acético!

 **Medidas** (ver página 29)

 **Exemplos de montagem**  
(ver página 18)

 **Desmontar** (ver página 28)

 **Peças de substituição**  
(ver página 30)

XXX = Acabamentos  
670 = Matt Black  
700 = Matt White

 **Acessórios especiais**  
(não incluído no volume de fornecimento)

- Peças da instalação #96179000 (ver página 30)
- Peças da instalação #94268000 (ver página 30)

 **Limpeza** (ver página 31)

## Montagem

(ver página 19) 

**Wskazówki bezpieczeństwa**

- △ Aby uniknąć zranień na skutek zgniecenia lub przecięcia, podczas montażu należy nosić rękawice ochronne.
- △ Produktu nie wolno używać jako uchwytu do trzymania się. Należy zamontować osobny uchwyt.
- △ Przechowywać z dala od dzieci.

**Wskazówki montażowe**

- Przed montażem należy skontrolować produkt pod kątem szkód transportowych. Po montażu nie widać żadnych szkód transportowych ani szkód na powierzchni.
- Powierzchnie przylegania muszą posiadać odpowiednią nośność, być wolne od środków antyadhezyjnych, wosku, smaru oraz być czyste i suche. W większości przypadków najlepszą opcją jest po prostu mocne przetarcie powierzchni czystą i suchą szmatką. Nie stosować konwencjonalnych czyszczaczy zawierających środki antyadhezyjne. W razie potrzeby używać czyszczaczy na bazie czystego alkoholu, a w przypadku woskowanych kamieni naturalnych czyszczaczy rozpuszczających wosk. Przed ewaporacją przetrzeć czystą, suchą szmatką.
- W określonym czasie (co roku) należy sprawdzać właściwe zamocowanie i odpowiednie osadzenie zamontowanych produktów.

**Opis symbolu**

Nie stosować silikonów zawierających kwas octowy!



**Wymiary** (patrz strona 29)



**Przykłady montażowe**  
(patrz strona 18)



**Demontaż** (patrz strona 28)



**Części serwisowe** (patrz strona 30)

XXX = Kody kolorów  
670 = Matt Black  
700 = Matt White



**Wyposażenie specjalne**  
(Nie jest częścią dostawy)



- Elementy mocujące #96179000 (patrz strona 30)



- Elementy mocujące #94268000 (patrz strona 30)



**Czyszczenie** (patrz strona 31)

**Montaż**

(patrz strona 19)

**Bezpečnostní pokyny**

- △ Pro zabránění řezným zraněním a pohmožděninám je nutné při montáži nosit rukavice.
- △ Produkt nesmí být používán jako madlo. Je nutné namontovat samostatné madlo.
- △ Nesmí se dostat dětem do rukou.

**Pokyny k montáži**

- Před montáží je třeba produkt zkontrolovat, zda nebyl při transportu poškozen. Po zabudování nebudou uznány žádné škody způsobené transportem nebo poškození povrchu.
- Styčné plochy musí mít dostatečnou nosnost, nesmí se na nich vyskytovat separační látky, musí být suché, čisté a bez zbytků vosku a tuků. Ve většině případů je nejlepší, plochu pouze pevně vydrhnout suchým a čistým hadrem. Nepoužívejte běžné čisticí prostředky obsahující separační látky. V případě potřeby použijte na čištění čistý alkohol a na voskovaných přírodních kamenech čisticí prostředek rozpouštějící vosk. Před odpařením vydrhněte čistým suchým hadrem.
- Upevnění podle předpisů a pevně usazení montovaných produktů je třeba kontrolovat v periodických časových intervalech (ročně).

**Popis symbolů**

Nepoužívat silikon s obsahem kyseliny octové!



**Rozměry** (viz strana 29)



**Příklady montáže** (viz strana 18)



**Demontáž** (viz strana 28)



**Servisní díly** (viz strana 30)

XXX = Kód povrchové úpravy  
670 = Matt Black  
700 = Matt White



**Zvláštní příslušenství**  
(není součástí dodávky)



- montážní díly #96179000 (viz strana 30)



- montážní díly #94268000 (viz strana 30)



**Čištění** (viz strana 31)

**Montáž**

(viz strana 19)



**Bezpečnostné pokyny**

- △ Pri montáži musíte nosiť rukavice, aby ste predišli pomliaždeninám a rezným poraneniam.
- △ Výrobok sa nesmie používať ako držadlo. K tomu účelu sa musí namontovať samostatné držadlo.
- △ Nesmie sa dostať do rúk deťom.

**Pokyny pre montáž**

- Pred montážou musíte produkt skontrolovať, či nebol počas transportu poškodený. Po zabudovaní nebudú uznané žiadne škody spôsobené transportom alebo poškodenia povrchu.
- Plochy určené na prifínutie musia byť únosné, bez uvoľňovacích prostriedkov, čisté, suché, bez voskov a tukov. Vo väčšine prípadov je najlepšie vhodné vyutierať plochu iba pomocou čistej a suchej handričky. Nepoužívajte bežné čističe s obsahom uvoľňovacích prostriedkov. V prípade potreby použite čistý alkoholový čistič a pri voskovaných prírodných kameňoch čističe rozpúšťajúce vosk. Pred odparovaním pretrite čistou, suchou handričkou.
- Upevnenie podľa predpisov a pevné osadenie montovaných produktov treba kontrolovať v periodických časových intervaloch (ročne).

**Popis symbolov**

 Nepoužívať silikón s obsahom kyseliny octovej!

 **Rozmery** (viď strana 29)

 **Príklady montáže** (viď strana 18)

 **Demontáž** (viď strana 28)

 **Servisné diely** (viď strana 30)

XXX = Farebné označenie

670 = Matt Black

700 = Matt White

 **Zvláštne príslušenstvo**

(nie je súčasťou dodávky)

 • montážne diely #96179000 (viď strana 30)

 • montážne diely #94268000 (viď strana 30)

 **Čistenie** (viď strana 31)

**安全技巧**

- △ 装配时为避免挤压和切割受伤, 必须戴上手套.
- △ 该产品不得作扶柄使用. 必须安装单独的扶柄.
- △ 儿童请勿触及.

**安裝提示**

- 安装前必须检查产品是否受到运输损害. 安装后将不认可运输损害或表面损伤.
- 表面必须稳定, 无脱模剂, 洁净, 干燥, 无蜡无油脂. 针对多数表面, 最好使用洁净干燥的毛巾用力擦拭. 请勿使用常规, 含脱模剂的清洁剂. 必要时可使用纯酒精清洁剂, 针对打蜡的天然石材可使用可溶解蜡质的清洁剂. 在汽化处理前先用洁净干燥的毛巾擦拭.
- 应定期 (每年) 检查已装配好的产品是否正常固定和固定定位.

**符号说明**

 请勿使用含有乙酸的硅胶!

 大小 (参见第页 29)

 安装示意 (参见第页 18)

 拆卸 (参见第页 28)

 备用零件 (参见第页 30)

XXX = 颜色代码

670 = Matt Black

700 = Matt White

 选装附件 (不在供货范围内)

• 安装附件 #96179000 (参见第页 30)

• 安装附件 #94268000 (参见第页 30)

 清洗 (参见第页 31)

**Montáž**  
(viď strana 19) 

**安裝**  
(参见第页 19) 

**Указания по технике безопасности**

- △ Во время монтажа следует надеть перчатки во избежание прищемления и порезов.
- △ Изделие запрещается использовать в качестве рукоятки. Следует устанавливать специальную рукоятку.
- △ Хранить в местах, не доступных детям.

**Указания по монтажу**

- Перед монтажом следует проверить изделие на предмет повреждений при перевозке. После монтажа претензии о возмещении ущерба за повреждения при перевозке или повреждения поверхностей не принимаются.
- Склеиваемые поверхности должны быть прочными, чистыми, сухими, на них не должно быть разделительных материалов, воска и жира. В большинстве случаев поверхность лучше всего только протереть куском чистой, сухой ткани. Не используйте обычные чистящие средства, содержащие разделительные вещества. При необходимости используйте чистящие средства из чистого спирта. Для ошлого природного камня используйте чистящие средства, растворяющие воск. До испарения дополнительно протрите куском чистой, сухой ткани.
- Надлежащее крепление и плотность посадки установленных изделий следует проверять регулярно (ежегодно).

**Описание символов**

 Не применяйте силикон, содержащий уксусную кислоту.

 **Размеры** (см. стр. 29)

 **варианты установки** (см. стр. 18)

 **Демонтаж** (см. стр. 28)

 **Комплект** (см. стр. 30)

XXX = Цветная кодировка  
670 = Matt Black  
700 = Matt White

 **Специальные принадлежности** (не включено в объем поставки!)

 • Крепежные детали #96179000 (см. стр. 30)

 • Крепежные детали #94268000 (см. стр. 30)

 **Очистка** (см. стр. 31)

**Монтаж**

(см. стр. 19)

**Turvallisuusohjeet**

- △ Asennuksessa on käytettävä käsiineitä puristumien ja viiltojen aiheuttamien tapaturmien estämiseksi.
- △ Tuotetta ei saa käyttää kädensijana. On asennettava erillinen kädensija.
- △ Ei saa joutua lasten käsiin.

**Asennusohjeet**

- Ennen asennusta on tarkastettava tuotteen mahdolliset kuljetusvahingot. Asennuksen jälkeen kuljetus- ja pintavaurioita ei hyväksytä.
- Tartuntapintojen tulee olla kantokykyisiä, vapaita erotusaineista, puhtaita, kuivia, vaha- ja rasvavapaita. Useimmissa tapauksissa on parasta, että pinnat hangataan puhtaaksi puhtaalla kuivalla liinalla. Älä käytä mitään tavanomaista irrotusainepitoista puhdistusainetta. Käytä tarvittaessa alkoholi-puhdistusainetta ja vahatuille luonnonkiville vahaapoistavaa puhdistusainetta. Jälkihankaa puhtaalla kuivalla liinalla ennen aineen haihtumista.
- Asennettujen tuotteiden asianmukainen kiinnitys ja tiukkuus on tarkastettava säännöllisin väliajoin (vuosittain).

**Merkin kuvaus**

Älä käytä etikkahappopitoista silikonia!

**Mitat** (katso sivu 29)**Asennusesimerkkejä** (katso sivu 18)**Irrotus** (katso sivu 28)**Varaosat** (katso sivu 30)

XXX = Värikoodaus  
670 = Matt Black  
700 = Matt White

**Eriyisvaruste** (ei kuulu toimitukseen)

• Kiinnitysosat #96179000 (katso sivu 30)

• Kiinnitysosat #94268000 (katso sivu 30)

**Puhdistus** (katso sivu 31)**Asennus**

(katso sivu 19)



**Säkerhetsanvisningar**

- △ Handskar ska bäras under monteringsarbetet så att man kan undvika kläm- och skärskador.
- △ Produkten får inte användas som handtag. Ett separat handtag måste monteras.
- △ Förvaras oåtkomligt för barn.

**Monteringsanvisningar**

- Det måste undersökas om produkten har transportskador innan den monteras. Efter monteringen accepteras inga transport- eller ytskiktsskador.
- Fästytan måste vara hållbar, fri från lösningsmedel, ren, torr, vax- och fettfri. I de flesta fall är det enklast att torka av fästytan med en ren och torr trasa. Använd inga konventionella rengöringsmedel. Vid behov kan en alkoholhaltig rengöringsvätska användas, för vaxad natursten skall ett vaxlösande rengöringsmedel användas. Torka av ytan med en ren, torr trasa innan rengöringsvätskan förångas.
- Alla monterade produkter ska kontrolleras regelbundet (varje år) så att de sitter fast ordentligt.

**Symbolförklaring**

Använd inte silikon som innehåller ättiksyra!



**Måtten** (se sidan 29)



**Monteringsexempel** (se sidan 18)



**Demontering** (se sidan 28)



**Reservdelar** (se sidan 30)

XXX = Färgkodning  
670 = Matt Black  
700 = Matt White



**Specialtillbehör**

(medföljer ej leveransen)



• Monteringsdelar #96179000 (se sidan 30)

• Monteringsdelar #94268000 (se sidan 30)



**Rengöring** (se sidan 31)

**Saugumo technikos nurodymai**

- △ Apsaugai nuo užspaudimo ir įsijovimo montavimo metu mūvėkite pirštines.
- △ Gaminys neturi būti naudojamas kaip rankena. Rankena montuojama atskirai.
- △ Laikykite vaikams neprieinamoje vietoje.

**Montavimo instrukcija**

- Prieš montuojant būtina patikrinti, ar gaminys nebuvo pažeistas transportavimo metu. Sumontavus pretenzijos dėl transportavimo ir paviršiaus pažeidimų nepriimamos.
- Klijuojami paviršiai turi būti pakankamai tvirti, nepadengti skiriamosiomis medžiagomis, švarūs, sausi, nevaškuoti ir neriebaluoti. Dauguma atvejų prieš klijavimą juos geriausia nutrinti švaria ir sausa šluoste. Nenaudokite įprastinių, skiriamųjų medžiagų sudėtyje turinčių valiklių. Jei reikia, naudokite gryno alkoholio valiklius, o vaškuotiems natūralaus akmens paviršiams – vašką tirpdančius valiklius. Prieš išgaruojant, nutrinkite švaria ir sausa šluoste.
- Gaminį pritvirtinimo teisingumą ir patikimumą būtina periodiškai (kasmet) tikrinti.

**Simbolio aprašymas**

Nenaudokite silikono, kurio sudėtyje yra acto rūgšties!



**Išmatavimai** (žr. psl. 29)



**Montavimo pavyzdžiai** (žr. psl. 18)



**Išmontavimas** (žr. psl. 28)



**Atsarginės dalys** (žr. psl. 30)

XXX = Spalvos  
670 = Matt Black  
700 = Matt White



**Specialūs priedai** (nėra pridedama)

• Tvirtinimo detalės #96179000 (žr. psl. 30)

• Tvirtinimo detalės #94268000 (žr. psl. 30)



**Valymas** (žr. psl. 31)

**Montering**

(se sidan 19)



**Montavimas**

(žr. psl. 19)



**Sigurnosne upute**

- ⚠ Prilikom montaže se radi sprječavanja prignječenja i posjekotina moraju nositi rukavice.
- ⚠ Proizvod ne smije služiti za pridržavanje. U tu se svrhu mora postaviti zaseban rukohvat.
- ⚠ Čuvati izvan dohvata djece.

**Upute za montažu**

- Prije montaže mora se provjeriti je li proizvod oštećen prilikom transporta. Nakon ugradnje se ne priznaju nikakve reklamacije koje se odnose na površinska i transportna oštećenja.
- Površine koje se lijepe moraju biti nosive, bez separatora, čiste, suhe i očišćene od eventualnih masnoća i voska. U većini slučajeva najbolje je površine dobro prebrisati samo čistom i suhom krpom. Nemojte rabiti uobičajena sredstva za čišćenje koja sadrže separatore. Ako je to potrebno, možete upotrijebiti čisto alkoholno sredstvo za čišćenje, a kod voskiranog prirodnog kamena sredstvo za čišćenje koje otapa i uklanja vosak. Prije isparavanja prebrišite suhom i čistom krpom.
- U redovitim vremenskim razmacima (jednom godišnje) valja provjeravati propisnu pričvršćenost i stabilnost postavljenih proizvoda.

**Opis simbola**

 Nemojte koristiti silikon koji sadrži octenu kiselinu!

 **Mjere** (pogledaj stranicu 29)

 **Primjeri instalacija**  
(pogledaj stranicu 18)

 **rastavljanje** (pogledaj stranicu 28)

 **Rezervni djelovi**  
(pogledaj stranicu 30)

XXX = Boje

670 = Matt Black

700 = Matt White

 **Posebni pribor**  
(Nije sadržano u isporuci!)

 • Dijelovi za učvršćivanje #96179000  
(pogledaj stranicu 30)

 • Dijelovi za učvršćivanje #94268000  
(pogledaj stranicu 30)

 **Čišćenje** (pogledaj stranicu 31)

**Sastavljanje**

10 (pogledaj stranicu 19) 

**Instrucțiuni de siguranță**

- ⚠ La montare utilizați mănuși pentru evitarea contuziunilor și tăierii mâinilor.
- ⚠ Nu este permisă utilizarea produsului pe post de mâner. este nevoie de montarea unui mâner corespunzător.
- ⚠ Nu lăsați produsul la îndemâna copiilor.

**Instrucțiuni de montare**

- Înainte de instalare verificați, dacă produsul prezintă deteriorări de transport. După instalare garanția nu acoperă deteriorările de transport și cele de suprafață.
- Suprafețele de suport trebuie să fie stabile, curate, nu trebuie să fie acoperite cu materiale antiaderente, ceară sau unsoare. În majoritatea cazurilor este de ajuns să curățați suprafața cu o cârpă curată și uscată. Nu utilizați soluții de curățat convenționale, care ar putea eventual să conțină materiale antiaderente. Dacă este nevoie utilizați soluție de curățat pe bază de alcool, iar în cazul suprafețelor de piatră cerată o soluție de curățat cu proprietăți de dizolvare a cerii. Înainte de evaporare ștergeți suprafața temeinic cu o cârpă curată și uscată.
- Fixarea corespunzătoare și poziția fixă a produselor montate trebuie verificate la intervale regulate (anual).

**Descrierea simbolurilor**

 Nu utilizați silicon cu conținut de acid acetic!

 **Dimensiuni** (vezi pag. 29)

 **Exemple de montare** (vezi pag. 18)

 **Demontare** (vezi pag. 28)

 **Piese de schimb** (vezi pag. 30)

XXX = Coduri de culori

670 = Matt Black

700 = Matt White

 **Accesorii opționale**  
(nu este inclus în setul livrat)

 • Piese pentru montare #96179000  
(vezi pag. 30)

 • Piese pentru montare #94268000  
(vezi pag. 30)

 **Curățare** (vezi pag. 31)

**Montare**

(vezi pag. 19) 

**Υποδειξεις ασφαλείας**

- ⚠ Για να αποφύγετε τραυματισμούς κατά τη συναρμολόγηση πρέπει να φοράτε γάντια.
- ⚠ Το προϊόν δεν επιτρέπεται να χρησιμοποιείται σαν λαβή στήριξης. Για τον σκοπό αυτό πρέπει να τοποθετηθεί ξεχωριστή λαβή στήριξης.
- ⚠ Να φυλάσσεται μακριά από παιδιά.

**Οδηγίες συναρμολόγησης**

- Πριν τη συναρμολόγηση πρέπει να εξεταστεί το προϊόν για ζημιές μεταφοράς. Μετά την εγκατάσταση δεν αναγνωρίζονται ζημιές από τη μεταφορά ή επιφανειακές ζημιές.
- Οι επιφάνειες πρέπει να είναι σταθερές, απαλλαγμένες από παράγοντες αποδέσμευσης, και καθαρές και στεγνές από κηλίδα και λίπος. Στις περισσότερες περιπτώσεις το καλύτερο είναι να τρίψετε σταθερά όλη την επιφάνεια με ένα καθαρό και στεγνό πανί. Μην χρησιμοποιείτε τα συμβατικά καθαριστικά που περιέχουν απορρυπαντικά. Καθαρίστε με καθαριστικά που περιέχουν αλκοόλη εάν είναι απαραίτητο και με καθαριστικά μέσα κεριών για κερωμένες φυσικές πέτρες. Τρίψτε πριν εξατμισθεί με ένα καθαρό και στεγνό πανί.
- Θα πρέπει να ελέγχετε ανά διαστήματα (ετησίως) αν η στερέωση εξακολουθεί να είναι επαρκής και αν τα τοποθετημένα προϊόντα στηρίζονται καλά.

**Περιγραφή συμβόλων**

 Μην χρησιμοποιείτε σιλικόνη που περιέχει οξικό οξύ!

**Διαστάσεις** (βλ. Σελίδα 29)

 **Παραδείγματα συναρμολόγησης**  
(βλ. Σελίδα 18)

 **Αποσυναρμολόγηση**  
(βλ. Σελίδα 28)

 **Ανταλλακτικά** (βλ. Σελίδα 30)  
XXX = Χρώματα  
670 = Matt Black  
700 = Matt White

 **Ειδικά αξεσουάρ** (δεν περιλαμβάνεται στον παραδοτέο εξοπλισμό)

- εξαρτήματα στερέωσης #96179000 (βλ. Σελίδα 30)
- εξαρτήματα στερέωσης #94268000 (βλ. Σελίδα 30)

 **Καθαρισμός** (βλ. Σελίδα 31)

**Συναρμολόγηση**  
(βλ. Σελίδα 19) 

**Varnostna opozorila**

- ⚠ Pri montaži je treba nositi rokavice, da se preprečijo poškodbe zaradi zmečkanja ali urezov.
- ⚠ Proizvoda ne smete uporabljati kot držalnega ročaja. V ta namen je treba montirati poseben ročaj.
- ⚠ Ne sme priti v roke otrokom.

**Navodila za montažo**

- Pred montažo je treba izdelek preveriti glede morebitnih transportnih poškodb. Po vgradnji transportne ali površinske poškodbe ne bodo več priznane.
- Oprijemalne površine morajo biti dovolj nosilne, brez ločevalnih slojev, čiste, suhe, brez voska in maščob. V večini primerov je najbolje površino temeljito zdrgniti le s suho in čisto krpo. Ne uporabljajte običajnih čistil za ločilna sredstva. Po potrebi uporabite čista alkoholna čistila in pri naravnem kamnu čistila za vosek. Pred izhlapevanjem obrišite s suho in čisto krpo.
- V periodičnih presledkih (letno) je treba preverjati pravilno pritrditev in trdnost naseda montiranih proizvodov.

**Opis simbola**

Ne smete uporabiti silikona, ki vsebuje ocetno kislino!



**Mere** (glejte stran 29)



**Primeri montaže** (glejte stran 18)



**Demontaža** (glejte stran 28)



**Rezervni deli** (glejte stran 30)

XXX = Barve  
670 = Matt Black  
700 = Matt White



**Poseben pribor** (Ni vključeno)



- Pritrdilni deli #96179000 (glejte stran 30)
- Pritrdilni deli #94268000 (glejte stran 30)



**Čiščenje** (glejte stran 31)

**Montaža**

(glejte stran 19) 



## Ohutusjuhised

- △ Kandke paigaldamisel muljumis- ja löikevigastuste vältimiseks kindaid.
- △ Toodet ei tohi kasutada käepidemena. Paigaldage eraldi käepide.
- △ Hoidke laste käeulatusest väljas.

## Paigaldamisjuhised

- Enne paigaldamist tuleb toodet kontrollida transpordikahjustuste osas. Pärast paigaldamist ei tunnustata enam transpordi- või pinnakahjustuste kaebuseid.
- Nakkumispiinnad peavad olema kandevoimelised, eraldusaineta, puhtad, kuivad ja vahata ja määrdata. Enamikul juhtudel on parim hõõruda pinda üksnes puhta ja kuiva riidega. Mitte kasutada tavapäraseid, eraldusainet sisaldavaid puhastusvahendeid. Vajadusel kasutada alkoholivaba ja vahatatud loodusliku kivi puhul vaha lahustavat puhastusvahendit. Enne aurustumist hõõruda puhta ja kuiva riidega.
- Monteeritud toote nõuetekohast paigaldust ja kinnitust tuleb korrapäraselt (kord aastas) kontrollida.

## Sümbolite kirjeldus

 Ärge kasutage äädikhapet sisaldavat silikooni!

 **Mõõtude** (vt lk 29)

 **Paigalduse näited** (vt lk 18)

 **Mahamonteerimine** (vt lk 28)

 **Varuosad** (vt lk 30)

XXX = Värvid  
670 = Matt Black  
700 = Matt White

 **Spetsiaalne lisavarustus**  
(ei sisaldu komplektis)

- Kinnitusdetailid #96179000 (vt lk 30)
- Kinnitusdetailid #94268000 (vt lk 30)

 **Puhastamine** (vt lk 31)

## Drošības norādes

- △ Montāžas laikā, lai izvairītos no saspiedumiem un iegriezumiem, nepieciešams nēsāt cimdus.
- △ Šo produktu nedrīkst izmantot kā roku balstu. Nepieciešams uzmontēt atsevišķu roku balstu.
- △ Uzglabājiet bērniem nepieejamās vietās.

## Norādījumi montāžai

- Pirms montāžas nepieciešams pārbaudīt, vai produktam transportēšanas laikā nav radušies bojājumi. Pēc iebūvēšanas bojājumi, kas radušies transportēšanas laikā, vai virsmas bojājumi netiek atzīti.
- Līmējamām virsmām jābūt izturīgām, tīrām, sausām, atdalosiem slāņiem, vaskam un taukiem jābūt noņemtiem. Parasti pietiek kārtīgi noslaucīt virsmu ar tīru un sausu auduma gabalu. Nelietojiet parastos tīrīšanas līdzekļus, kas satur atdalošas vielas. Nepieciešamības gadījumā lietojiet tīrīšanas līdzekli uz tīra alkohola bāzes. Pirms izvaiķošanas noslaucīt ar tīru, sausu auduma gabalu.
- Nepieciešams periodiski (reizi gadā) pārbaudīt, vai uzmontētie produkti ir pareizi piestiprināti un labi turas.

## Simbolu nozīme

 Neizmantojiet silikonu, kas satur etiķskābi!

 **Izmērus** (skat. lpp. 29)

 **Montāžas piemēri** (skat. lpp. 18)

 **Demontāža** (skat. lpp. 28)

 **Rezerves daļas** (skat. lpp. 30)

XXX = Krāsu kodi  
670 = Matt Black  
700 = Matt White

 **Speciāli aksesuāri**  
(komplektā netiek piegādāts)

 • Stiprinājuma daļas #96179000 (skat. lpp. 30)

 • Stiprinājuma daļas #94268000 (skat. lpp. 30)

 **Tīršana** (skat. lpp. 31)

## Paigaldamine

(vt lk 19) 

## Montāža

(skat. lpp. 19) 



**Sigurnosne napomene**

- ⚠ Prilikom montaže se radi sprečavanja prignječenja i posekotine moraju nositi rukavice.
- ⚠ Proizvod se ne sme koristiti za kao ručka za pridržavanje. U tu svrhu se mora postaviti zaseban rukohvat.
- ⚠ Čuvati van domašaja dece.

**Instrukcije za montažu**

- Pre montaže se mora proveriti da li je proizvod oštećen pri transportu. Nakon ugradnje se ne priznaju nikakve reklamacije koje se odnose na površinska i transportna oštećenja.
- Površine koje se lepe moraju da budu nosive, bez separatora, čiste, suve i očišćene od eventualnih masnoća i voska. U većini slučajeva najbolje je površine dobro prebrisati samo čistom i suvom krpom. Nemojte upotrebljavati ubičajena sredstva za čišćenje koja sadrže separatore. Ako je neophodno, možete upotrebiti čisto alkoholno sredstvo za čišćenje, a kod voskiranog prirodnog kamena sredstvo za čišćenje koje rastvara i uklanja vosak. Pre isparavanja prebršite suvom i čistom krpom.
- Propisna pričvršćenost i stabilnost postavljenih proizvoda treba redovno da se proverava (jednom godišnje).

**Opis simbola**

Nemojte koristiti silikon koji sadrži sirćetnu kiselinu!



**Mere** (vidi stranu 29)



**Primeri montaže** (vidi stranu 18)



**rastavljanje** (vidi stranu 28)



**Rezervni delovi** (vidi stranu 30)

XXX = Oznake boja

670 = Matt Black

700 = Matt White



**Poseban pribor**

(Nije sadržano u isporuci)



- Delovi za pričvršćivanje #96179000 (vidi stranu 30)



- Delovi za pričvršćivanje #94268000 (vidi stranu 30)



**Čišćenje** (vidi stranu 31)

**Montaža**

(vidi stranu 19)

**Sikkerhetshenvisninger**

- ⚠ Bruk hansker under montasjen for å unngå klem- og kuttskader.
- ⚠ Produktet skal ikke brukes som holdegrep. Det skal monteres en separat holdegrep.
- ⚠ Oppbevares utilgjengelig for barn.

**Montagehenvisninger**

- Før montasjen skal produktet sjekkes for transportskader. Etter monteringen aksepteres ikke noen transport- eller overflateskader.
- Overflaten må ha bæreevne, vre fri for slippmidler, rene, tørre og fri for voks og fett. I de fleste tilfelle er det best å gni overflaten godt med en ren, tørr klut. Ikke bruk vanlige rengjøringsmidler som inneholder skillemidler. Ved behov kan ren alkohol brukes, og ved vokset naturstein brukes et voksløsende rengjøringsmiddel. Gni før fordamping med en ren, tørr klut.
- De monterte produktene skal regelmessig sjekkes om de er ordentlig festet og om de sitter fast.

**Symbolbeskrivelse**

Ikke bruk silikon som inneholder eddiksyre!



**Mål** (se side 29)



**Montasje-eksempel** (se side 18)



**Demontasje** (se side 28)



**Service deler** (se side 30)

XXX = Fargekode

670 = Matt Black

700 = Matt White



**Ekstratilbehør** (ikke med i leveransen)



- Fstedeler #96179000 (se side 30)



- Fstedeler #94268000 (se side 30)



**Rengjøring** (se side 31)

**Montasje**

(se side 19)





## Указания за безопасност

- △ При монтажа трябва да се носят ръкавици, за да се избегнат наранявания поради притискане или порязване.
- △ Продуктът не бива да се използва като дръжка. Трябва да се монтира отделна дръжка.
- △ Не бива да попада в ръцете на деца.

## Указания за монтаж

- Преди монтажа продуктът трябва да се провери за транспортни щети. След монтажа не се признават транспортни или повърхностни щети.
- Повърхностите за слепване трябва да са товароосими, без разделителни средства, чисти, сухи, без вакса и мазнини. В повечето случаи е най-добре, повърхността да бъде изтрита добре с чиста и суха кърпа. Не използвайте конвенционални почистващи препарати, съдържащи разделителни средства. При нужда използвайте чисти почистващи препарати със съдържание на алкохол, а при намазан с вакса естествен камък използвайте почистващи препарати, които разтварят въска. Преди изпаряване изтъркайте допълнително с чиста суха кърпа.
- Правилното закрепване и правилното разположение на монтираните продукти трябва да се проверява периодично (ежегодно).

## Описание на символите

 Не използвайте силикон, съдържащ оцетна киселина!

 **Размери** (вижте стр. 29)

 **Примери за монтаж** (вижте стр. 18)

 **Демонтаж** (вижте стр. 28)

 **Сервизни части** (вижте стр. 30)

XXX = Цветово кодиране  
670 = Matt Black  
700 = Matt White

 **Специални принадлежности**  
(не се съдържа в обема на доставка)

 • Закрепващи части #96179000  
(вижте стр. 30)

 • Закрепващи части #94268000  
(вижте стр. 30)

 **Почистване** (вижте стр. 31)

## Монтаж

(вижте стр. 19) 

## 安全上の注意

- △ 施工の際は手を挟んだり怪我をしないように、手袋をはめてください。
- △ 製品は取っ手として使用できません。必要に応じて別途取っ手を設置してください。
- △ 子供の手の届かないところに保管してください。

## 施工上の注意

- 製品の施工前に輸送でのダメージがないか確認してください。施工後のキズ等のお申し出はお断りさせていただきます。
- 接着面は、耐荷重が高く、きれいで特殊なコーティングが無く、乾燥しており、ワックスやグリースが付いていない必要があります。通常、きれいな乾いた布で表面をきれいにしてください。界面活性剤を含む洗剤は使用しないでください。必要に応じて、純粋なアルコール系のクリーナー や石材の場合は材質に応じて天然石用のワックスクリナーを使用します。乾燥前にきれいな乾いた布で作業をしてください。
- 取付金具や固定ネジなど、製品の取付状態を定期的に (年に一度) チェックしてください。

## アイコンの説明



酢酸系シリコンをご使用にならないでください!



**寸法** (次のページを参照 29)



**施工例** (次のページを参照 18)



**取り外し** (次のページを参照 28)



**スペアパーツ** (次のページを参照 30)

XXX = 仕上げ色  
670 = Matt Black  
700 = Matt White



**スペシャルパーツ** (別手配部品)



• 取付金具セット #96179000  
(次のページを参照 30)



• 取付金具セット #94268000  
(次のページを参照 30)



**お手入れ方法** (次のページを参照 31)

## 施工方法

(次のページを参照 19) 

**Udhëzime sigurie**

- △ Për të evituar lëndimet e pickimeve ose të prerjeve gjatë procesit të montimit duhet që të vishni doreza.
- △ Produkti nuk duhet të përdoret si dorëzë mbajtëse. Duhet të montohet një dorëzë mbajtëse e veçantë
- △ Nuk lejohet të bie në duart e fëmijëve.

**Udhëzime për montimin**

- Përpara montimit duhet që produkti të kontrollohet për dëmtime nga transporti. Pas instalimit nuk do të njihet asnjë dëmtim nga transporti ose dëmtim i sipërfaqes.
- Sipërfaqet e ngjitjes duhet të jenë të afta për të mbajtur, të lira nga substancat ndarëse, të pastra, të thata, pa rrëshirë dhe yndyrë. Në shumicën e rasteve është më mirë ta fërkoni fort sipërfaqen vetëm me një leckë të pastër dhe të thatë. Mos përdorni asnjë pastrues konvencional që përmban substanca ndarëse. Në rast nevojë përdorni pastrues të pastër alkooli dhe tek gurët natyror përdorni pastrues që lahen me ujë. Para avullimit fërkoheni me një leckë të pastër të thatë.
- Montimi dhe pozicioni sipas rregullave i produkteve të montuara duhet verifikuar periodikisht (një herë në vit).

**Përshkrimi i simbolit**

Mos përdorni silikon që në përbërje ka acid acetik.



**Përmasat** (shih faqen 29)



**Shembuj të montimit** (shih faqen 18)



**Çmontimi** (shih faqen 28)



**Pjesët e servisit** (shih faqen 30)

XXX = Kodimi me anë të ngjyrave  
670 = Matt Black  
700 = Matt White



**Pajisje të posaçme**

(nuk përfshihet në vëllimin e furnizimit)



• Pjesët mbërthëse #96179000  
(shih faqen 30)



• Pjesët mbërthëse #94268000  
(shih faqen 30)



**Pastrimi** (shih faqen 31)

**Montimi**

(shih faqen 19)

**تعليمات الأمان**

- △ يجب ارتداء قفازات لليد أثناء التركيب لتجنب حدوث أخطار الإنحشار أو الجروح.
- △ ممنوع استخدام المنتج كمقبض. يجب تركيب مقبض منفصل.
- △ يُحفظ بعيدًا عن متناول الأطفال.

**تعليمات التركيب**

- قبل القيام بعملية التركيب، يجب فحص المنتج للتأكد من خلوه من أية تالفات ناتجة عن النقل. بعد القيام بعملية التركيب، لن يتم الاعتراف بوجود أية تالفات سطحية أو تالفات ناتجة عن عملية النقل.
- يجب أن تكون أسطح التلاصق صلبة وخالية من مواد الفصل ونظيفة وجافة وخالية من الشمع والشحوم. في معظم الحالات من الأفضل مسح وفرك الأسطح باستخدام قطعة قماش نظيفة وجافة. لا يتم استخدام المنظفات التقليدية التي تحتوي على مواد فصل. عند الحاجة يتم استخدام منظفات كحولية والمنظفات المذيبة للشمع في حالة الأحجار الطبيعية المغطاة بالشمع. يتم الفرك قبل التبخر باستخدام قطعة قماش جافة ونظيفة.
- يتعين التأكد من أن حالة التثبيت مطابقة للشروط المحددة والتأكد من الوضع الثابت للمنتجات المركبة على فترات منتظمة (سنويًا)

**وصف الرمز**

هام! لا تستخدم السليكون الذي يحتوي على أحماض!



**أبعاد** (راجع صفحة 29)



**مثال على التركيب** (راجع صفحة 18)



**فك التركيب** (راجع صفحة 28)



**قطع الغيار** (راجع صفحة 30)



XXX = الألوان  
Matt Black = 670  
Matt White = 700

**ملحقات خاصة**



(غير مدرج مع المحتويات المسلمة)

• طقم التركيب #96179000  
(راجع صفحة 30)



• طقم التركيب #94268000  
(راجع صفحة 30)



**التنظيف** (راجع صفحة 31)

**التركيب**

(راجع صفحة 19)











**Güvenlik uyarıları**

- △ Montaj esnasında ezilme ve kesilme gibi yaralanmaları önlemek için eldiven kullanılmalıdır.
- △ Ürün tutma kolu olarak kullanılmamalıdır. Ayrı bir tutma kolu monte edilmelidir.
- △ Çocukların eline geçmemelidir.

**Montaj açıklamaları**

- Montaj işleminden önce ürün nakliye hasarları yönünden kontrol edilmelidir. Montaj işleminden sonra nakliye veya yüzey hasarları için sorumluluk üstlenilmemektedir.
- Yarışma yüzeyleri yüklenebilir, ayırıcılardan arınmış, temiz, kuru, parafin ve yağdan arınmış olmalıdır. Birçok durumda, yüzeyi sadece temiz ve kuru bir bezle iyice ovalamak en iyi çözümdür. Geleneksel, ayırıcı içeren temizleyiciler kullanmayın. Gerekirse saf alkollü temizleyiciler ve parafinli doğal taşlarda parafin çözücü temizleyiciler kullanın. Buharlaşmadan önce temiz ve kuru bir bezle ovalayın.
- Monte edilmiş ürünlerin talimatlara uygun sabitliği ve sıkı duruşu düzenli aralıklarla (yıllık) kontrol edilmelidir.

**Simge açıklaması**

-  Asetik asit içeren silikon kullanmayın!
-  **Ölçüleri** (bakınız sayfa 29)
-  **Montaj Örneği** (bakınız sayfa 18)
-  **Sökme** (bakınız sayfa 28)
-  **Yedek Parçalar** (bakınız sayfa 30)  
XXX = Renkler  
670 = Matt Black  
700 = Matt White
-  **Özel aksesuarlar**  
(Teslimat kapsamına dahil değildir)
-  • Sabitleme parçaları #96179000  
(bakınız sayfa 30)
-  • Sabitleme parçaları #94268000  
(bakınız sayfa 30)
-  **Temizleme** (bakınız sayfa 31)

**Garanti Belgesi****Üretici veya İthalatçı Firmasının**

Unvanı: Hansgrohe Armatür Ltd. Şti  
Adresi: Fulya Mahallesi Bahçeler Sokak Efe han 20/C  
Mecidiyeköy Şişli İstanbul  
Telefonu: (0-212) 273 07 30  
Faks: (0-212) 273 07 40  
web adresi: www.hansgrohe.com.tr

**Malın**

Markası: Hansgrohe  
Cinsi: Sıhhi tesisat malzemesi  
Garanti Süresi: 2 YIL  
Azami Tamir Süresi: 20 İş günü

**Genel Müdür**

Albert Emlek



Satıcı Firmasının:  
Unvanı:  
Adresi:  
Telefonu:  
Faks:  
e-posta:  
Fatura Tarih ve Sayısı:  
Marka ve Modeli:  
Teslim Tarihi ve Yeri:  
Yetkilinin İmzası:  
Firmanın Kaşesi:  
Bu bölümü, ürünü aldığınız Yetkili Satıcı imzalayacak ve kaşeleyecektir.



## Biztonsági utasítások

- ⚠️ A szerelésnél a zúzdások és vágási sérülések elkerülése érdekében kesztyűt kell viselni.
- ⚠️ A terméket nem szabad kapaszkodónak használni. Ehhez külön kapaszkodót kell felszerelni.
- ⚠️ Nem szabad, hogy gyermekek kezébe kerüljön.

## Szerelési utasítások

- A szerelés előtt ellenőrizni kell, hogy a terméknek nincs-e szállítási sérülése. Beépítés után a szállítási-vagy felületi sérüléseket nem ismerik el.
- A ragasztási felületeknek szilárdnak, elválasztóanyagtól mentesnek, tisztának, száraznak, viasz- és zsírmentesnek kell lennie. A legtöbb esetben az a legjobb, ha a felületet csak egy tiszta és száraz ronggyal erősen átdörzsöljük. Nem szabad hagyományos, elválasztóanyag tartalmú tisztítószer használni. Szükség esetén használjunk tiszta alkoholos tisztítószeret és viazzal bevont természetes kövek esetén viaszoldó tisztítót. Elpárolgás előtt egy tiszta, száraz ronggyal dörzsöljük át.
- A felszerelt termékek szabályszerű rögzítését és szilárd elhelyezkedését rendszeres időközönként (évente) ellenőrizni kell.

## Szimbólumok leírása

 Ne használjon ecetsavtartalmú szilikont!

 **Méretet** (lásd a oldalon 29)

 **Szerelési példák** (lásd a oldalon 18)

 **Leszerelés** (lásd a oldalon 28)

 **Tartozékok** (lásd a oldalon 30)

XXX = Színkódolás  
670 = Matt Black  
700 = Matt White

 **Egyéb tartozék**

(a szállítási egység nem tartalmazza)

 • Rögzítőrészek #96179000  
(lásd a oldalon 30)

 • Rögzítőrészek #94268000  
(lásd a oldalon 30)

 **Tisztítás** (lásd a oldalon 31)

## הערות בטיחות

- ⚠️ יש להשתמש בכפפות בזמן ההתקנה כדי למנוע פציעות וחתכים
- ⚠️ אסור להשתמש במוצר כידית החזקה. יש להתקין ידית נפרדת
- ⚠️ הרחק מהישג ידם של ילדים!

## הוראות התקנה

- לפני ההתקנה, בדוק אם נגרמו למוצר נזקים בהובלה אחרי ההתקנה, לא נכיר בנזקים שנגרמו בהובלה או בנזקים במשטחים
- משטחי ההדבקה צריכים להיות נקיים, יבשים, ללא וקס וגריז, ועליהם להיות מסוגלים לשאת את המשקל ולהיות נקיים מחומרי שחרור. ברוב המקרים, עדיף לנגב את המשטח עם מטלית יבשה ונקייה. אסור להשתמש בחומרי ניקוי רגילים המכילים חומרים לשחרור תבניות. אם צריך, יש להשתמש בחומר ניקוי אלכוהולי. במקרה של אבן טבעית שיש עליה וקס, יש להשתמש בחומר ניקוי להסרת וקס. שפשף את החומר עם מטלית יבשה ונקייה לפני שהוא מתאייד.
- בדוק אחת לשנה את תקינות החיבור ואת האיטום של המוצרים המותקנים

## תיאור הסמל

! אסור להשתמש בסיליקון המכיל חומצה אצטית!

 **מידות** (ראה עמוד 29)

 **דוגמה להתקנה** (ראה עמוד 18)

 **פירווק** (ראה עמוד 28)

 **חלקי חילוף** (ראה עמוד 30)

XXX = צבעים  
670 = שחור מאט  
700 = לבן מאט

 **אביזרים מיוחדים** (הזמנה של פריט אקסטרה)

 • סט הרכבה #96179000 (ראה עמוד 30)

 • סט הרכבה #94268000 (ראה עמוד 30)

 **ניקוי** (ראה עמוד 31)

## הרכבה

(ראה עמוד 19) 

## הרכבה

(ראה עמוד 19) 

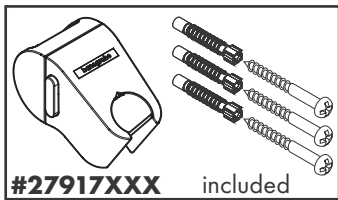
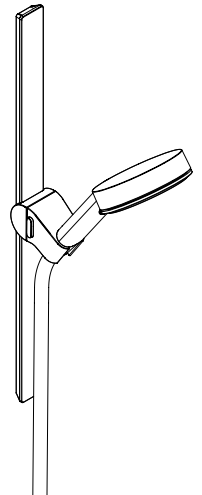
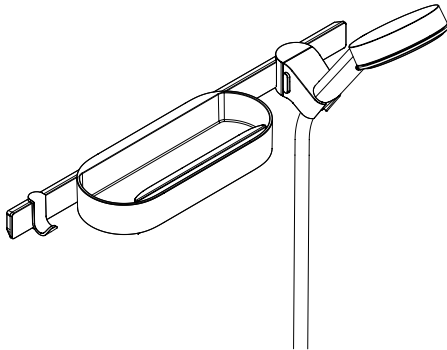
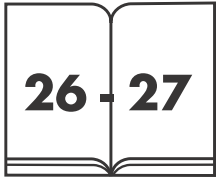
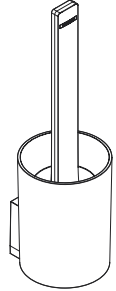
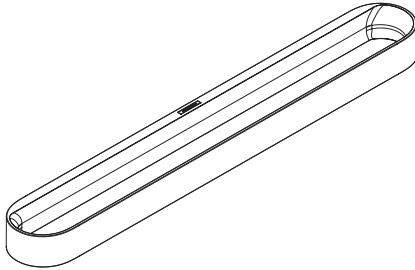
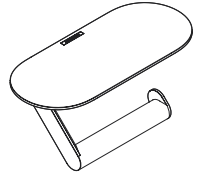
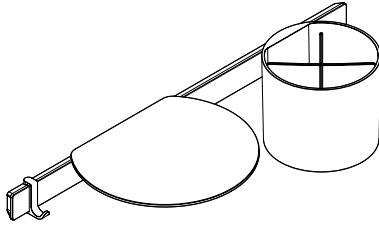
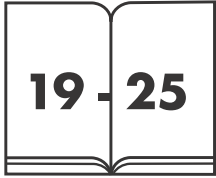

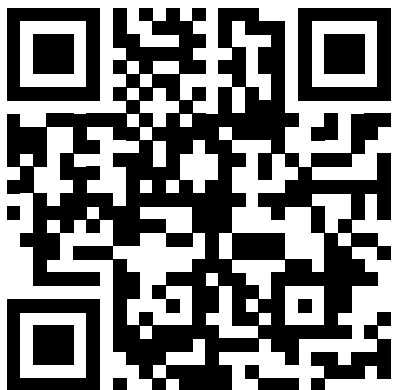

[www.hansgrohe.com/wallstoris](http://www.hansgrohe.com/wallstoris)

**1**



trocken, staub- und fettfrei / sec, sans poussière ni graisse / dry, free of dust and grease / asciutto, privo di polvere e grasso / seco, libre de polvo y grasa / droog, stof- en vetvrij / tør, støvfri og fedtfri / seco, sem gordura e pó / suchy, czysty i odtłuszczony / suché, bez prachu a tuku / suché, bez prachu a tuku / 干燥, 无尘且脱脂 / сухой, защищенный от пыли и без смазки / kuiva, pölytön ja rasvaton / Torr, damm- och fettfri / sausas, nedulkétas ir neriebus / suho, bez prašine i masnoća / uscat, fără praş şi grăsimi / στεγνό, χωρίς σκόνη και λάδια / suho, brez prahu in maščob / kuiv ning puhas tolmust ja rasvast / Sauss, bez putekliem un taukiem / suvo, bez prašine i masnoća / tørr, støvfri og fettfri / сухо, без прах и мазнили / 乾いていて、ほこりや油分無し / e thatê, pa pluhur dhe pa graso / جاف، وخال من الأتربة والشحوم / kuru, toz ve yağ içermez / száraz, por- és zsírmentes / יבש, נטול אבק וגריז

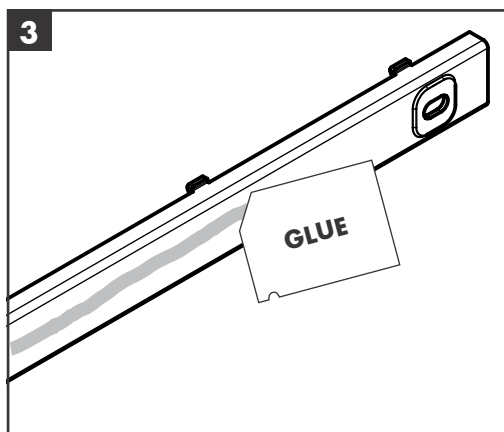
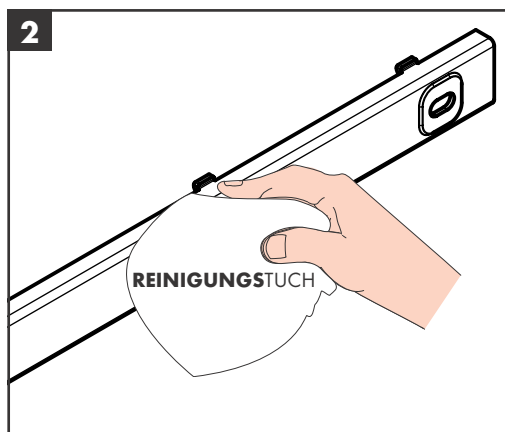

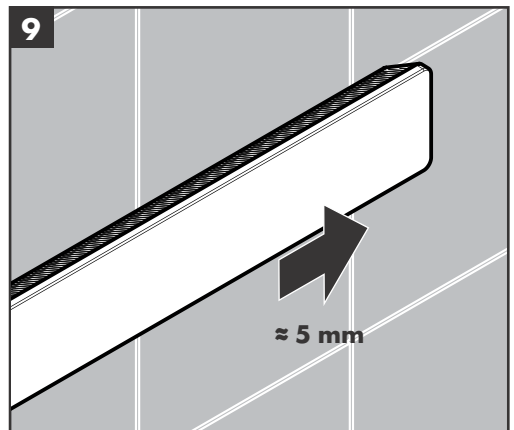
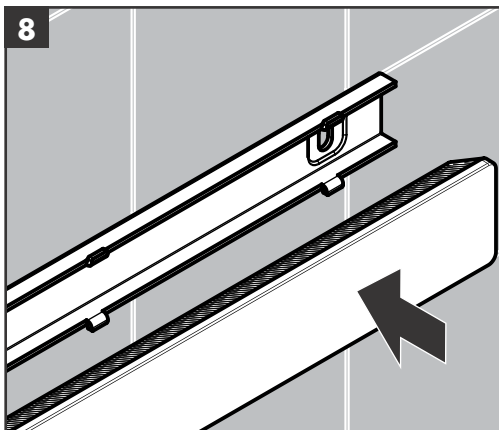
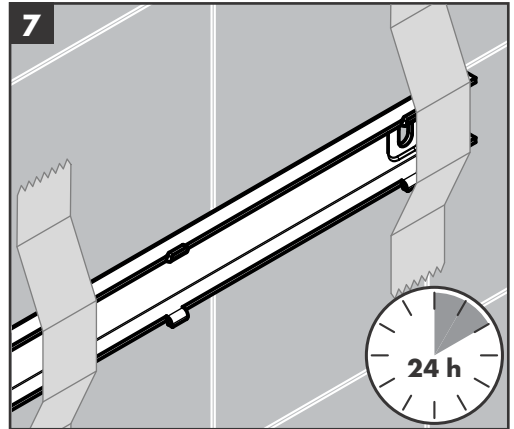
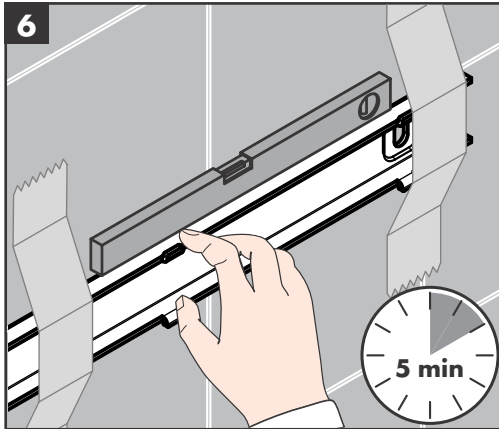
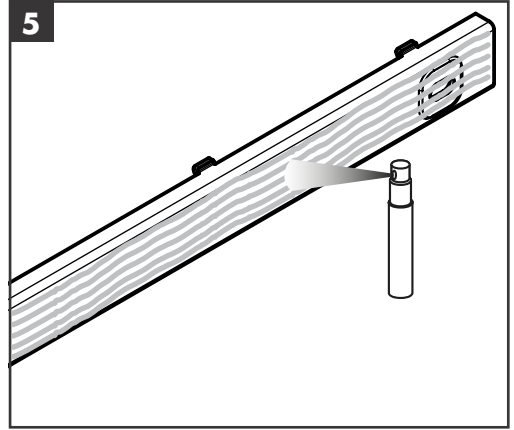
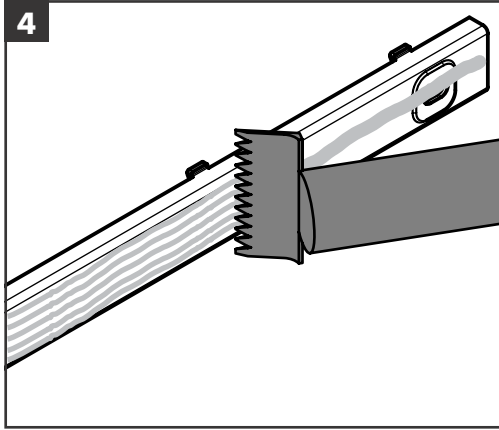



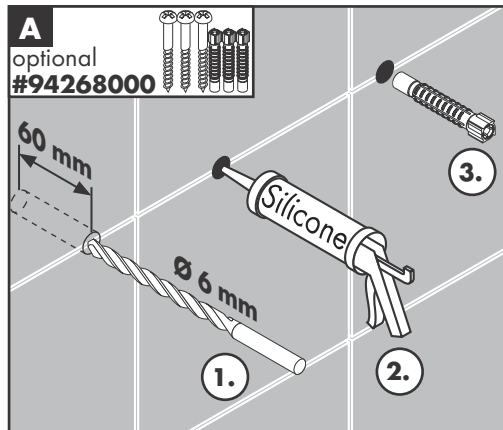
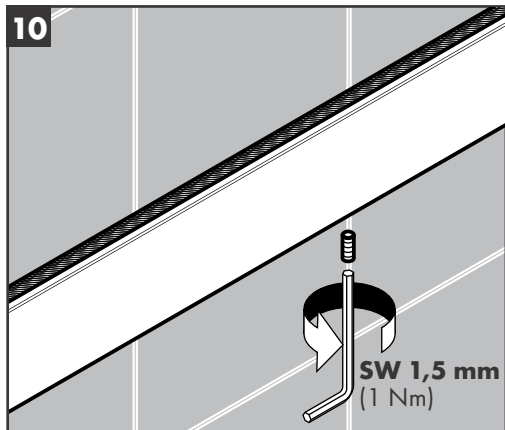

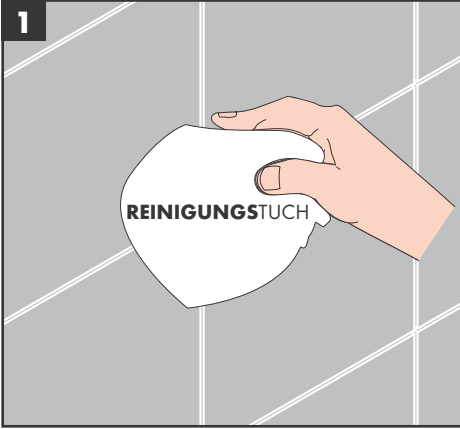

1 trocken, staub- und fettfrei / sec, sans poussière ni graisse / dry, free of dust and grease / asciutto, privo di polvere e grasso / seco, libre de polvo y grasa / droog, stof- en vetvrij / tør, støvfri og fedtfri / seco, sem gordura e pó / suchy, czysty i odtłuszczony / suché, bez prachu a tuku / suché, bez prachu a tuku / 干燥, 无尘且脱脂 / сухой, защищенный от пыли и без смазки / kuiva, pölytön ja rasvaton / Torr, damm- och fettfri / sausas, nedulkētas ir neriebūs / suho, bez prašine i masnoća / uscat, fără praț și grăsimi / στεγνό, χωρίς σκόνη και λάδια / suho, brez prahu in maščob / kuiv ning puhas tolmust ja rasvast / Sauss, bez putekljēm un taukiem / suvo, bez prašine i masnoća / tørr, støvfri og fettfri / сухо, без прах и мазины / 乾いていて, ほこりや油分無し / e thatè, pa pluhur dhe pa graso / جاف, وخال من الأتربة والشحوم / kuru, toz ve yağ içermez / száraz, por- és zsírmentes / יבש, נטול אבק וגריז

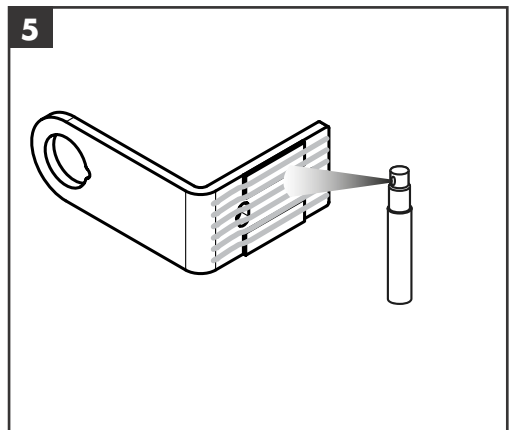
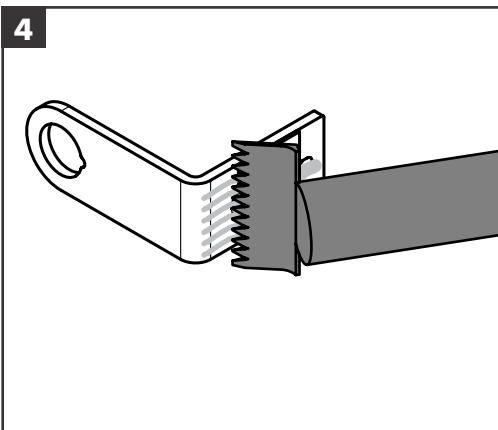
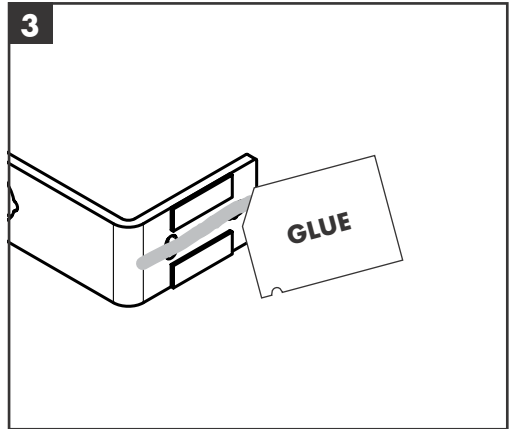
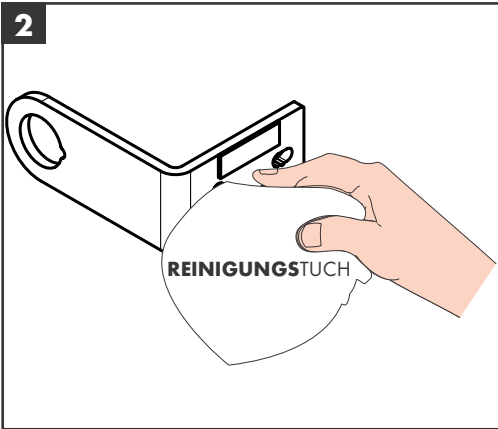

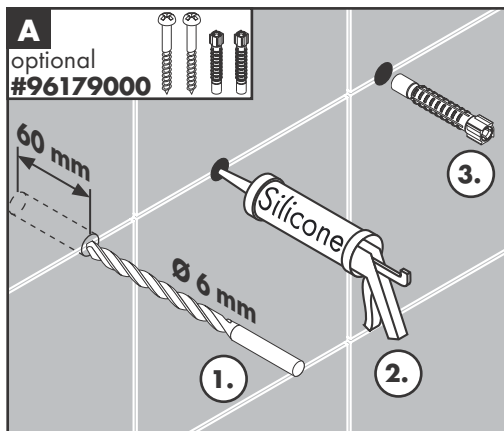
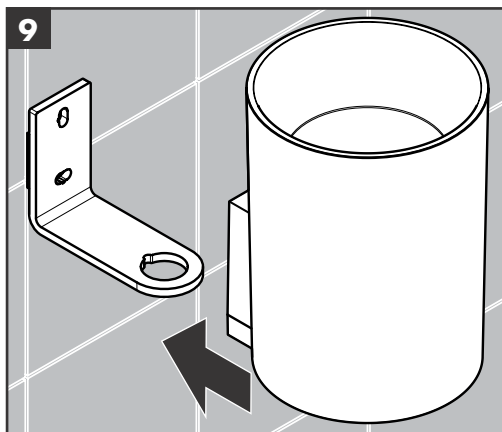
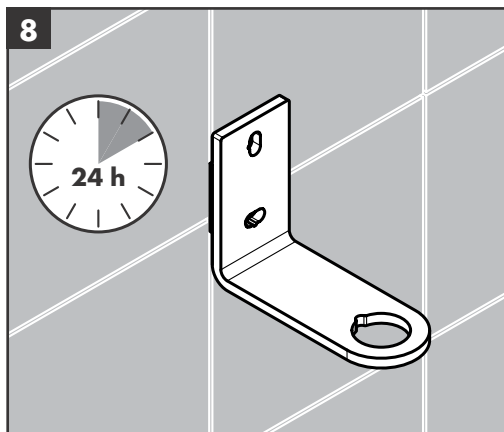
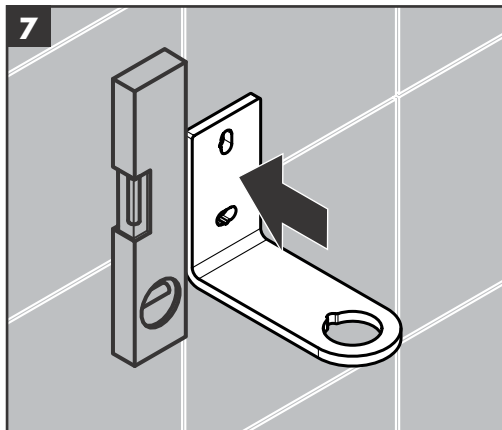
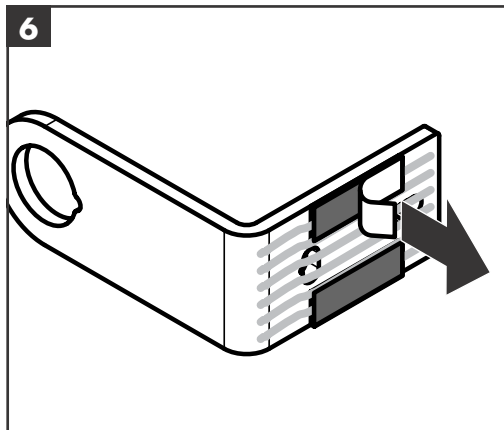

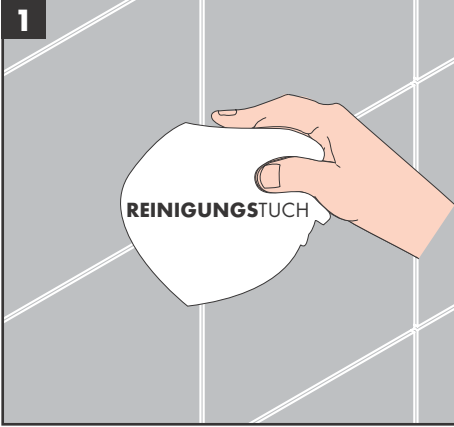

1 trocken, staub- und fettfrei / sec, sans poussière ni graisse / dry, free of dust and grease / asciutto, privo di polvere e grasso / seco, libre de polvo y grasa / droog, stof- en vetvrij / tør, støvfri og fedtfri / seco, sem gordura e pó / suchy, czysty i odtłuszczony / suché, bez prachu a tuku / suché, bez prachu a tuku / 干燥, 无尘且脱脂 / сухой, защищенный от пыли и без смазки / kuiva, pölytön ja rasvaton / Torr, damm- och fettfri / sausas, nedulkētas ir neriebūs / suho, bez prašine i masnoća / uscat, fără praş şi grăsimi / στεγνό, χωρίς σκόνη και λάδια / suho, brez prahu in maščob / kuiv ning puhas tolmust ja rasvast / Sauss, bez putekljēm un taukiem / suvo, bez prašine i masnoća / tørr, støvfri og fettfri / сухо, без прах и мазины / 乾いていて, ほこりや油分無し / e thatè, pa pluhur dhe pa graso / جاف، وخال من الأتربة والشحوم / kuru, toz ve yağ içermez / száraz, por- és zsírmentes / יבש, נטול אבק וגריז

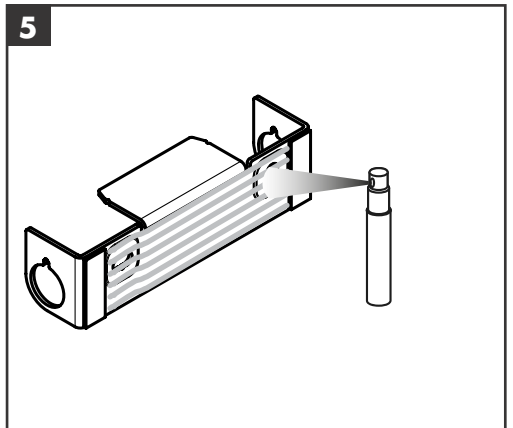
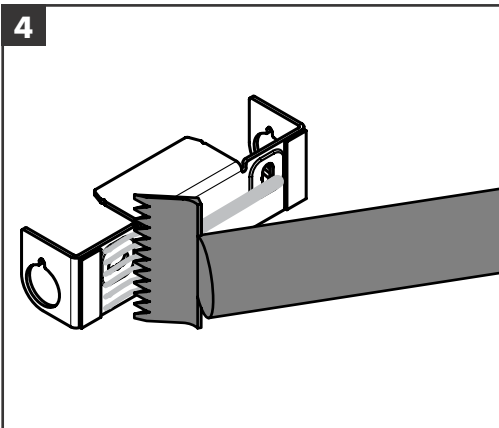
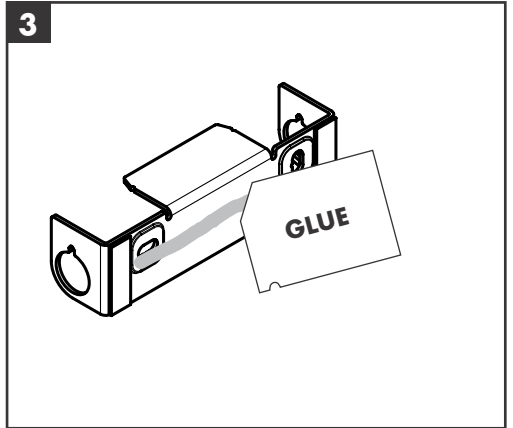
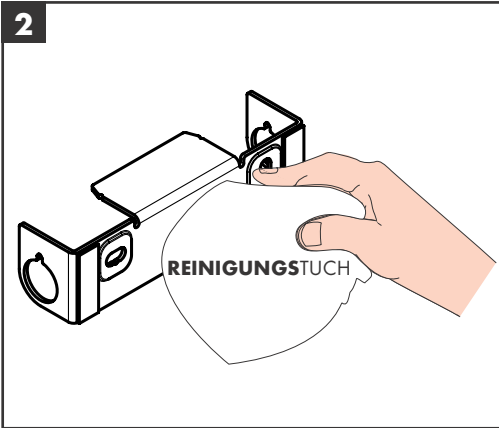

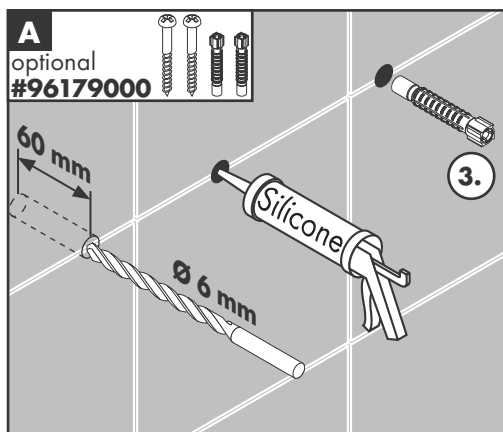
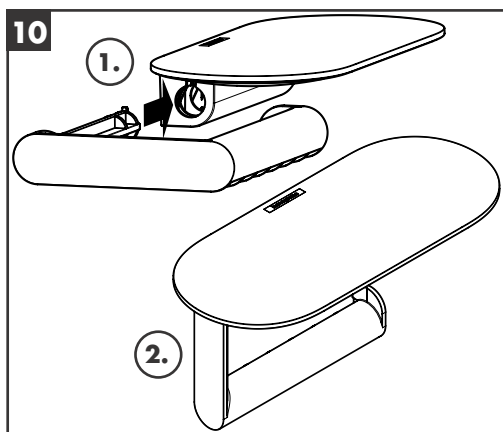
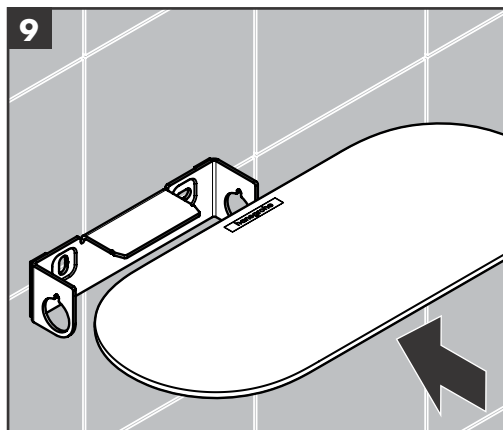
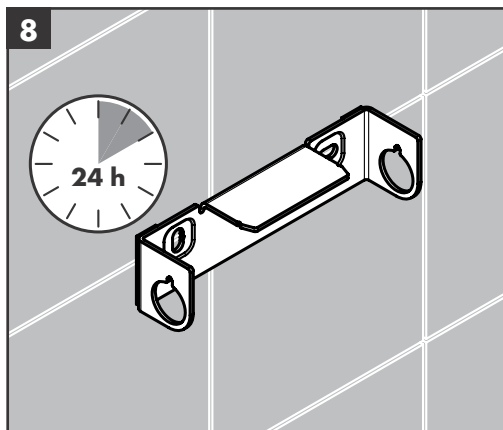
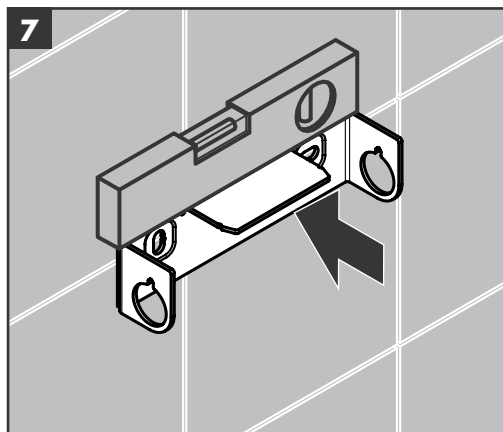
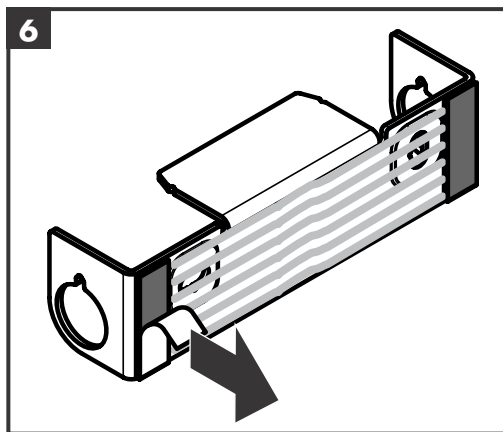

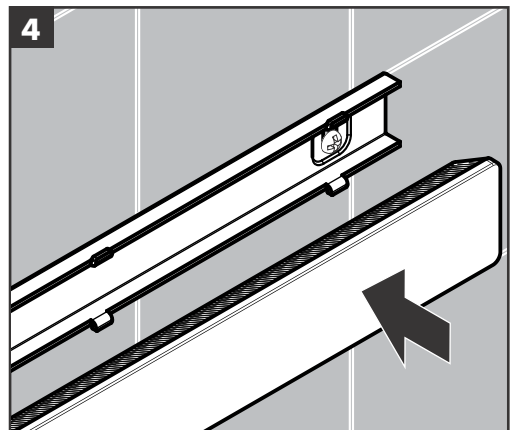
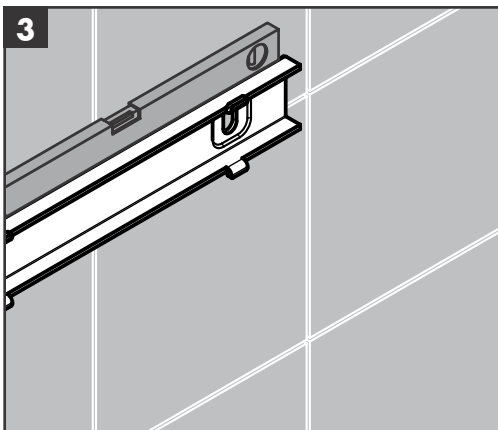
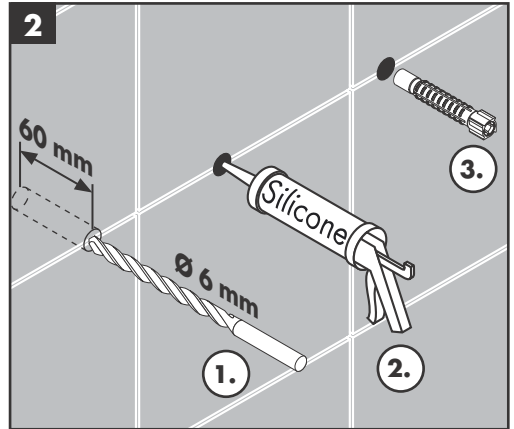
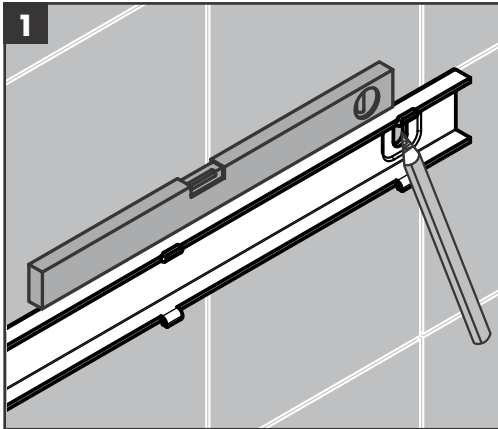
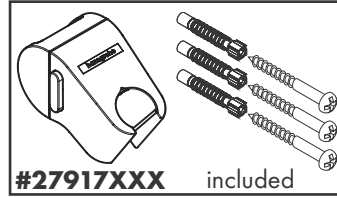
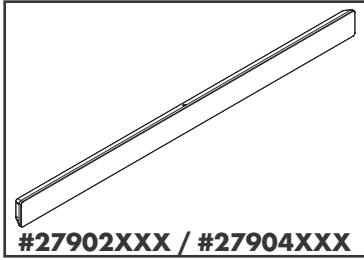

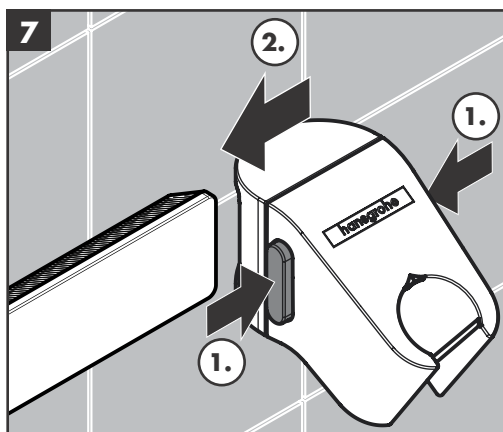
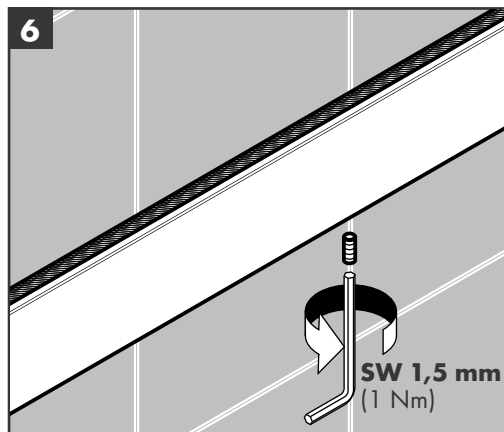
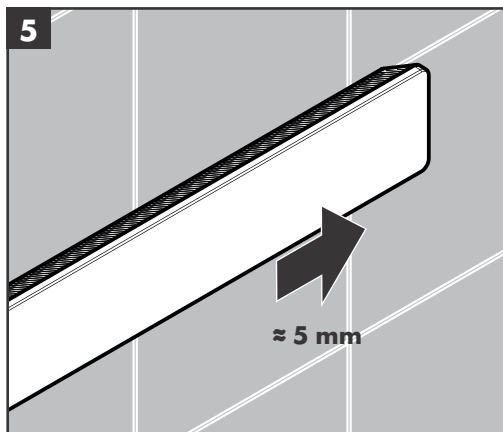

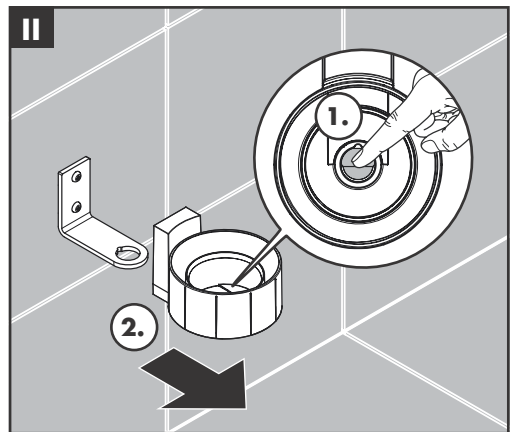
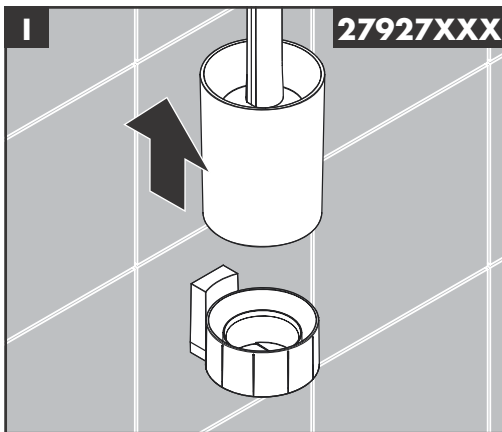
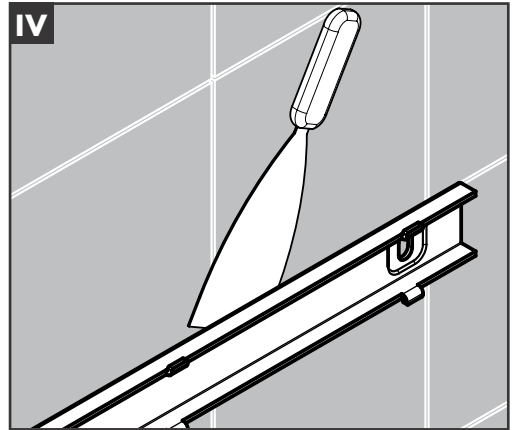
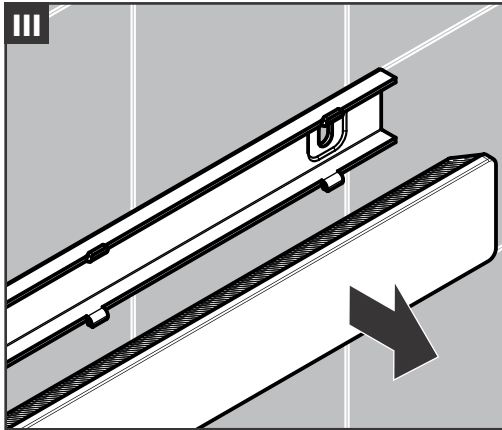
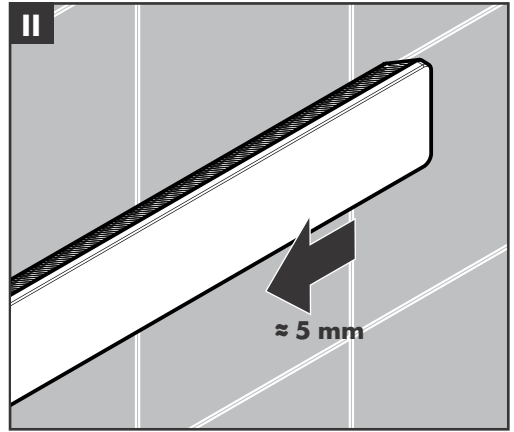
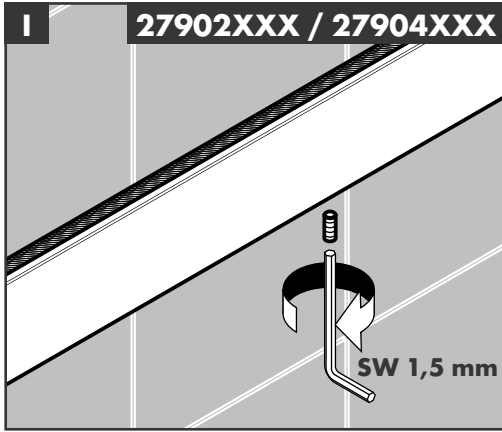





**WallStoris**  
27902XXX

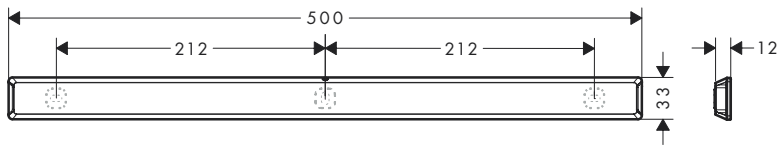

**WallStoris**  
27904XXX

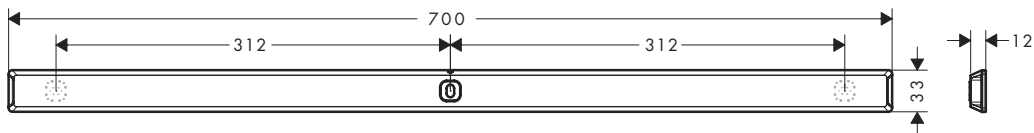

**WallStoris**  
27926XXX

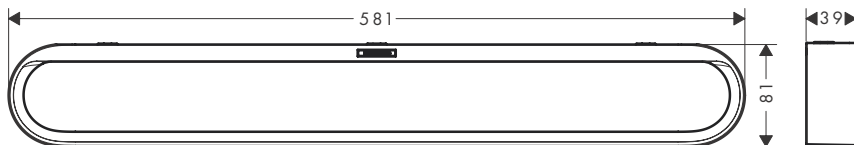

**WallStoris**  
27927XXX

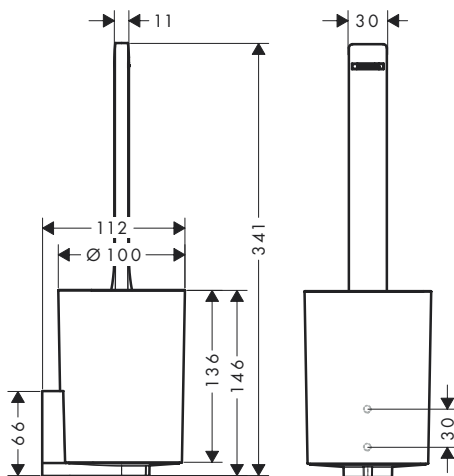

**WallStoris**  
27928XXX

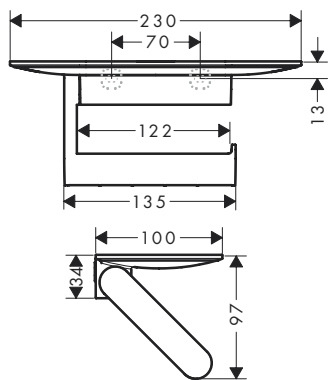

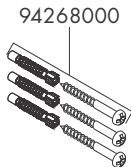
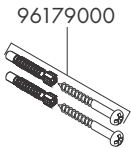
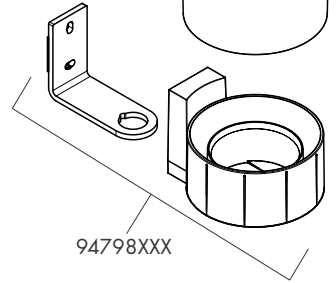
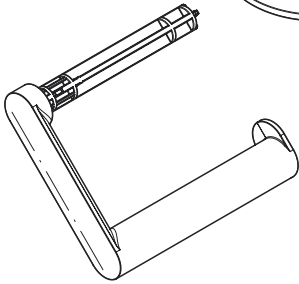
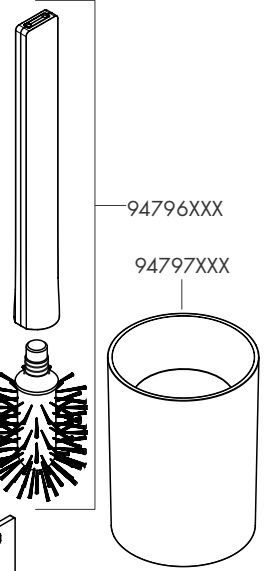
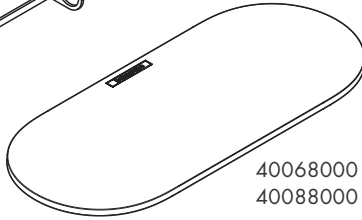
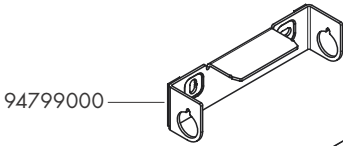
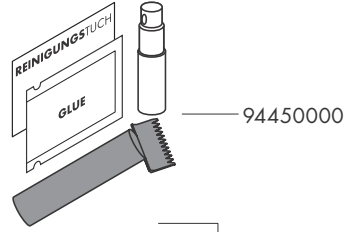
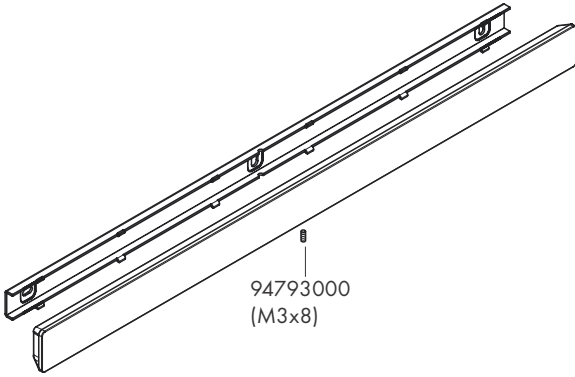



[www.hansgrohe.com/cleaning-recommendation](http://www.hansgrohe.com/cleaning-recommendation)

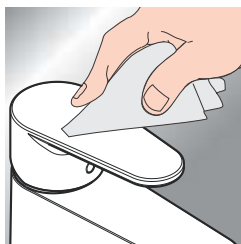

- DE** Reinigungsempfehlung / Garantie / Kontakt
- FR** Recommendation pour le nettoyage / Garanties / Contact
- EN** Cleaning recommendation / Warranty / Contact
- IT** Raccomandazione di pulizia / Garanzia / Contatto
- ES** Recomendaciones para la limpieza / Garantía / Contacto
- NL** Aanbevelingen inzake reiniging / Garantie / Contact
- DK** Rengøringsvejledning / Garanti / Kontakt
- PT** Recomendações de limpeza / Garantia / Contacto
- PL** Zalecenie dotyczące pielęgnacji / Gwarancja / Kontakt
- CS** Doporučení k čištění / Záruka / Kontakt
- SK** Odporúčania pre čistenie / Záruka / Kontakt
- ZH** 清洁指南 / 担保 / 接触
- RU** Рекомендации по очистке / Гарантия / Контакты
- FI** Puhdistussuositus / Takuu / Kosketus

- SV** Rengöringsrekommendationer / Garanti / Contacto
- LT** Valymo rekomendacijos / Garantija / Kontaktai
- HR** Preporuke za čišćenje / Garancija / Kontakt
- RO** Recomandări pentru curățare / Garanție / Contact
- EL** Σύσταση καθαρισμού / Εγγύηση / επαφή
- SL** Priporočilo za čiščenje / Garancija / Kontakt
- ET** Puhastussoovitused / Garantii / Kontakt
- LV** Tīrīšanas ieteikumi / Garantija / Kontakti
- SR** Preporuke za čišćenje / Garancija / Kontakt
- NO** Anbefaling for rengjøring / Garanti / Kontakt
- BG** Препоръка за почистване / Гаранция / Контакт
- JP** お手入れの方法 / 保証について / ご連絡先
- SQ** Këshilla rreth pastrimit / Garancia / Kontakt
- AR** توصيات التنظيف / الضمان / اتصال
- TR** Temizleme önerisi / Garanti / Temas
- HU** Tisztítási tanácsok / Garancia / érintkezés
- HE** המלצות לניקוי / אחריות / איש קשר

---

**hansgrohe**

Hansgrohe · Auestraße 5 · 9 · D-77761 Schiltach · Telefon +49 (0) 78 36/51-1282 · Telefax +49 (0) 7836/511440  
E-Mail: [info@hansgrohe.com](mailto:info@hansgrohe.com) · Internet: [www.hansgrohe.com](http://www.hansgrohe.com)

07/2022  
9.08273.01