

WF318110

WF318111

WF318112

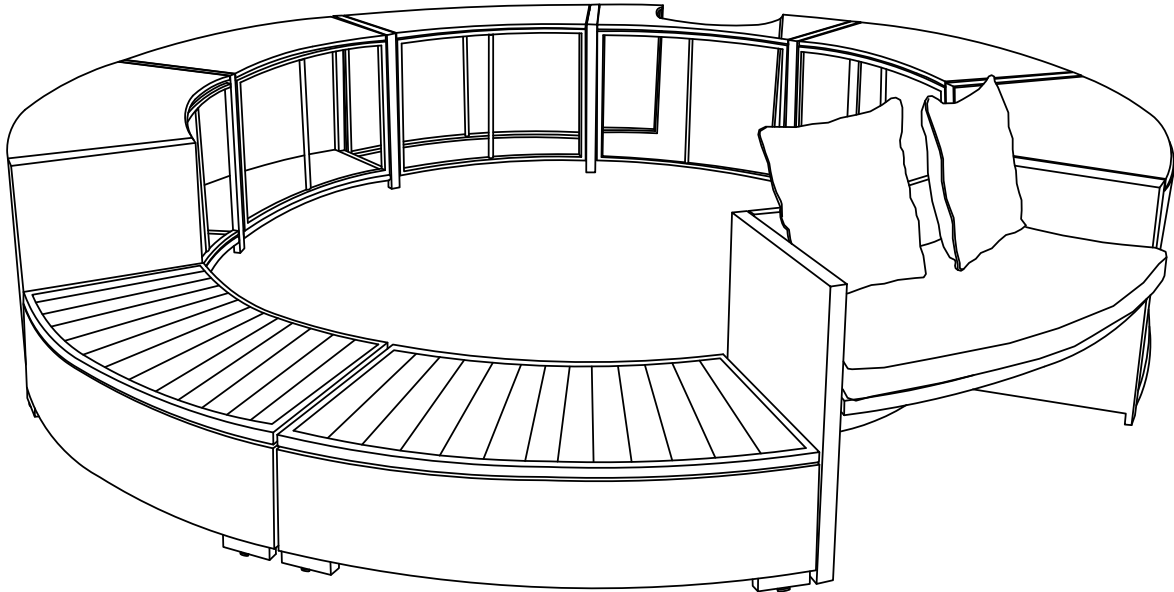

Montagedauer 2 Stunde
Assembling time 2 hour

Achtung!

- 1-Lesen Sie bitte sorgfältig unsere Montageanleitung, bevor Sie anfangen Ihr Produkt aufzubauen.
- 2-Der Aufbau Ihres Produktes soll auf einer sauberen und glatten Oberfläche durchgeführt werden. Wir empfehlen Ihnen die Verpackungskartons zu nutzen, um den Boden, auf dem die Montage stattfinden wird, zu abdecken.
- 3-Kontrollieren Sie bitte die Schrauben regelmäßig und bei Bedarf ziehen Sie erneut die Schrauben, die eventuell nicht mehr so fest sind.
- 4-Vermeiden Sie bitte den Kontakt zwischen scharfen Gegenständen und Ihrer Möbelloberfläche.
- 5-Bitte vermeiden Sie Stöße gegen Ihre Möbelloberfläche.
- 6-Ziehen Sie nicht alle Schrauben vollständig an, bis die Montage abgeschlossen ist.

Attention!

- 1-Please read the assembly instructions very carefully before assembling your product.
- 2-The product assembly has to be carried out on a clean and flat surface. We recommend the use of the packaging material (cartons/cardboards) to cover your room surface during assembly in order to protect the floor.
- 3-The screws and bolts of your furniture have to be tightened periodically.
- 4-Please avoid contact to sharp objects.
- 5-Please avoid hitting the furniture surface.
- 6-Do not fully tighten all screws until assembly is completed.

Ihr Produkt wird Ihnen in 3 Paketen zugestellt. Aufgrund unterschiedlicher Logistikunternehmen werden sich auch die Lieferzeiten der 3 Pakete unterscheiden.

DE: Vor dem Einbau die Schrauben in die Löcher stecken und festziehen, aber nicht bis 100%, 70% bis 80% anziehen reicht aus. Schließlich, nachdem alle Schrauben installiert sind, ziehen Sie alle Schrauben auf 100%. Wenn Sie auf diese Probleme stoßen, wie z. B. Fehlausrichtung der Löcher oder Unfähigkeit, bestimmte Teile zu installieren, überprüfen Sie bitte, ob die Schrauben korrekt verwendet werden und passen Sie die Dichtigkeit der Schrauben an.

GB: Before installation, insert the screws into the holes and tighten them, but do not tighten them to 100%, 70% to 80% is sufficient. Finally, after all screws are installed, tighten all screws to 100%. If you encounter these issues, such as if the holes cannot be aligned or some parts cannot be installed, please check if the screws are used correctly and adjust the tightness of the screws.

FR: Insérer la vis dans le trou avant la fin de l'assemblage, serrer la vis, mais ne pas serrer à 100%, 70% ~ 80% est correct. Enfin, une fois que toutes les vis sont bien serrées, toutes les vis sont serrées à 100%. Si vous rencontrez ces problèmes, par exemple si les trous ne sont pas alignés ou si certaines pièces ne peuvent pas être montées, vérifiez que les vis sont utilisées correctement et ajustez leur serrage.

**FR - Notice de montage / EN - Assembly instructions / PT - Instruções de montagem /
ES - Prospecto de montaje / DE - Montageanleitung / IT - Istruzioni di montaggio /
NL - Montagehandleiding**

FR - IMPORTANT! CONSERVER POUR CONSULTATION ULTERIEURE: LIRE ATTENTIVEMENT

- A monter par un adulte. Un adulte doit vérifier le bon assemblage avant l'emploi
- ATTENTION! tenir les vis et petits éléments et sachets hors de portée des enfants
- Bien identifier les éléments avant de commencer le montage
- Ne pas utiliser votre article lorsque l'un de ses éléments est cassé ou manquant
- En cas de problème contactez notre service après-vente
- Toujours suivre les instructions du fabricant
- Entretien: nettoyer avec un chiffon doux et sec. En cas de taches plus grosses, frottez soigneusement avec une éponge légèrement humide et non abrasive
- Ne pas sauter sur le lit

EN - IMPORTANT! KEEP FOR FUTURE REFERENCE: READ CAREFULLY

- To be assembled by an adult. Assembly must be checked by an adult before use
- WARNING! keep all screws, small parts and plastic bags out of the reach of children
- Properly identify all parts before assembling
- Never use your item if any of its parts are broken or missing
- Should any problems arise, please contact our After Sales Service
- Manufacturer's instructions shall be followed at all times
- Care: clean with a soft, dry cloth. In case of larger stains, carefully rub with a slightly damp, non-abrasive sponge
- Do not jump on the bed

PT - IMPORTANTE! GARDE PARA CONSULTA POSTERIOR: LER ESTAS INSTRUÇÕES CUIDADOSAMENTE

- A ser montado por um adulto. Um adulto deve verificar a boa montagem antes da utilização
- Atenção! mantenha os parafusos, acessórios pequenos e saco de plástico fora do alcance das crianças
- Identifique bem os acessórios antes de começar a montagem
- Não utilizar o artigo se um dos elementos está em falta ou danificado
- Para qualquer esclarecimento, contacte os nossos serviços através do telefone
- As instruções do fabricante devem ser sempre cumpridas
- Manutenção: limpe com um pano macio e seco. Em caso de manchas maiores, esfregue cuidadosamente com uma esponja ligeiramente húmida e não abrasiva
- Não salte na cama

ES - IMPORTANTE! CONSERVAR PARA FUTURAS CONSULTAS: LEER DETENIDAMENTE

- A montar por un adulto. Un adulto debe comprobar el buen montaje antes de la utilización
- ¡ADVERTENCIA! mantener los tornillos, los pequeños elementos y bolsitas fuera del alcance de los niños
- Identificar debidamente los elementos antes de empezar el montaje
- No utilizar este artículo si uno de los elementos falta o esta roto
- Si tiene problemas, contactar nuestro servicio postventa
- Deben seguirse siempre las instrucciones del fabricante Cuidados: limpiar con un paño suave y seco. En caso de manchas grandes, frotar con cuidado utilizando una esponja húmeda no abrasiva
- No saltar sobre la cama

DE - WICHTIG! FÜR SPÄTERE BEZUGNAHME AUFBEWAHREN: SORGFÄLTIG LESEN











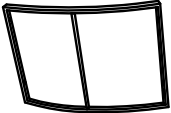
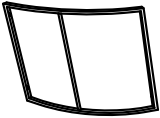





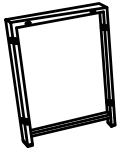
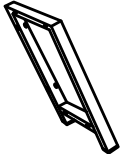
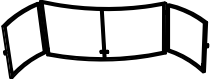

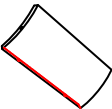
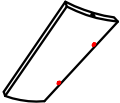
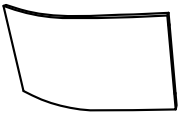

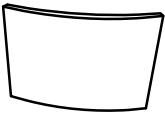

- Von einem Erwachsenen zu montieren. Die korrekte Montage muss vor Gebrauch von einem Erwachsenen geprüft werden
- Achtung! die Schrauben und kleinen Teile ausserhalb der Reichweite von Kindern lagern
- Vor Montagebeginn alle Teile identifizieren
- Ihren Artikel nicht benutzen, wenn eines seiner Bestandteile beschädigt ist oder fehlt
- Im Problemfall Ihren Kundendienst anrufen
- Stets die Herstelleranweisungen beachten
- Wartung: Mit einem weichen, trockenen Tuch reinigen. Bei größeren Flecken vorsichtig mit einem leicht feuchten, nicht scheuernden Schwamm abreiben
- Nicht auf dem Bett springen

IT - IMPORTANTE! CONSERVARE QUESTE INFORMAZIONI PER ULTERIORI CONSULTAZIONI: LEGGI ATTENTAMENTE

- Il montaggio deve essere eseguito da un adulto. Un adulto dovrà verificare il corretto montaggio prima dell'uso
- ATTENZIONE! tenere le viti ed i componenti di piccole dimensioni lontano dalla portata dei bambini
- Controllare i pezzi prima del montaggio
- L'articolo non deve essere utilizzato in caso di elementi mancanti o danneggiati
- In caso di necessità contattare il nostro servizio post-vendita
- Seguire sempre le istruzioni del costruttore
- Manutenzione: pulire con un panno morbido e asciutto. Per le macchine più grandi, strofinare accuratamente con una spugna leggermente umida e non abrasiva
- Non saltare sul letto

NL - BELANGRIJK! BEWAAR VOOR LATERE RAADPLEGING: LEES AANDACHTIG

- Moet door een volwassene worden gemonteerd. Voor gebruik moet een volwassene controleren dat het product goed in elkaar is gezet
- WAARSCHUWING! schroeven en kleine elementen en zakjes buiten bereik van kinderen houden
- De elementen goed identificeren alvorens met de montage te beginnen
- Uw artikel niet gebruiken wanneer een van de onderdelen kapot is of ontbreekt
- Neem bij problemen contact op met onze klantenservice
- Volg altijd de instructies van de fabrikant
- Onderhoud: maak schoon met een zachte en droge doek. In geval van grotere vlekken, veeg voorzichtig schoon met een licht bevochtigde en niet-schurende spons
- Niet springen op het bed

				
A1 * 1	A2 * 2	A3 * 3	B1 * 2	B2 * 1
				
B3 * 1	C1 * 1	C2 * 1	D1 * 1	D2 * 1
				
E * 1	F * 1	G1 * 1	G2 * 1	H * 2
				
I * 4	J * 3	K * 1	L * 1	M * 2
				
N1 * 1	N2 * 1	P1 * 1	P2 * 1	U * 5
				
R * 2	S * 1	M6*20 O * 8	M6*35 Q * 100	T * 2

WF318110



B1 * 2



B2 * 1



B3 * 1



C1 * 1

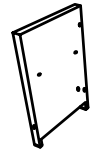

C2 * 1

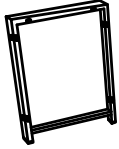

D1 * 1

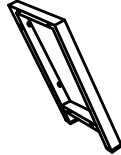

D2 * 1

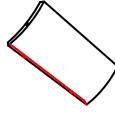

G1 * 1

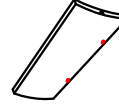

G2 * 1

WF318111



F * 1



J * 3



L * 1



U * 5



S * 1



M * 1

M6*20



O * 8

M6*35



Q * 100



T * 2

WF318112



A1 * 1

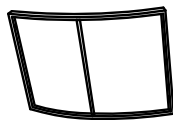

A2 * 2

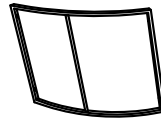

A3 * 3

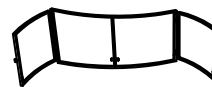

E * 1

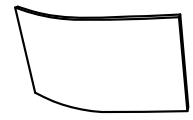

H * 2



K * 1



N1 * 1



N2 * 1



P1 * 1



P2 * 1



I * 4



M * 1



R * 2

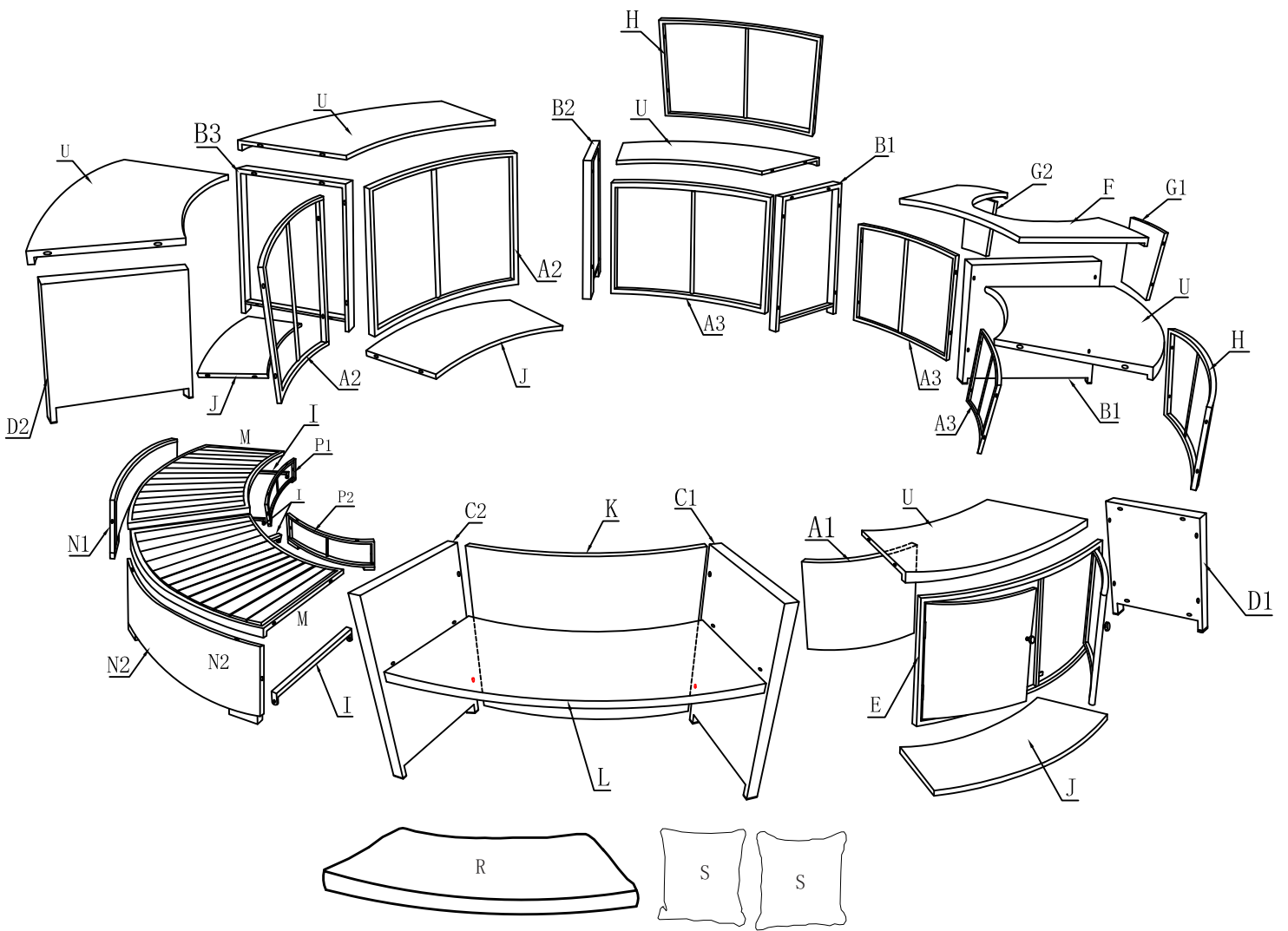

STEP1.

- A1 x1
- J x1
- C1 x1
- D1 x1
- Q x8

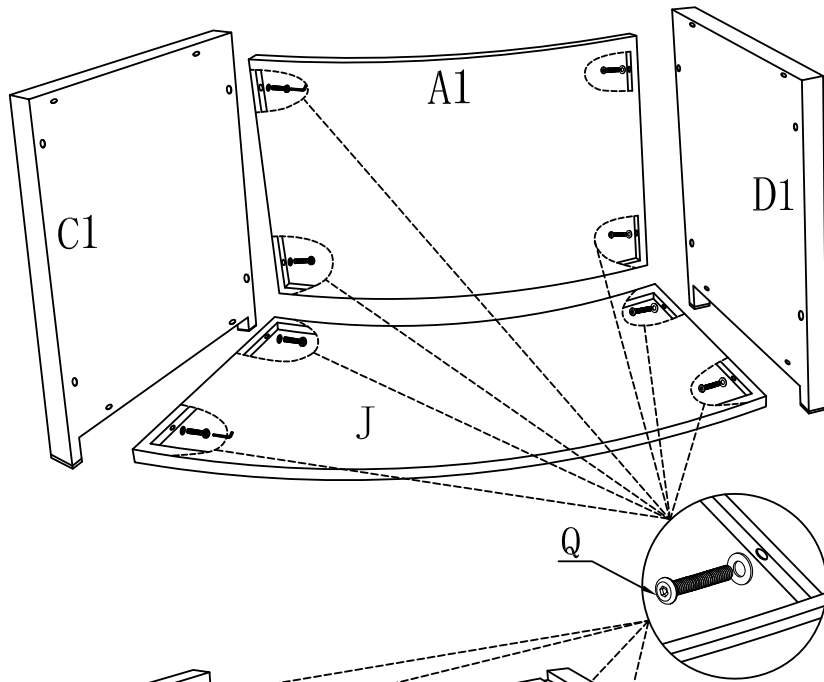

STEP2.

- U x1
- Q x4

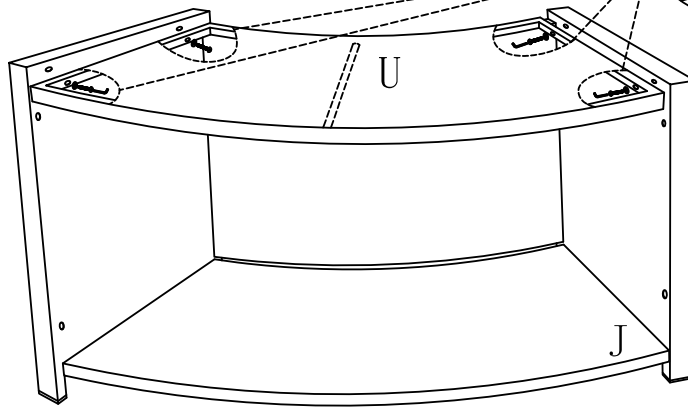

STEP3.

- E x1
- Q x4

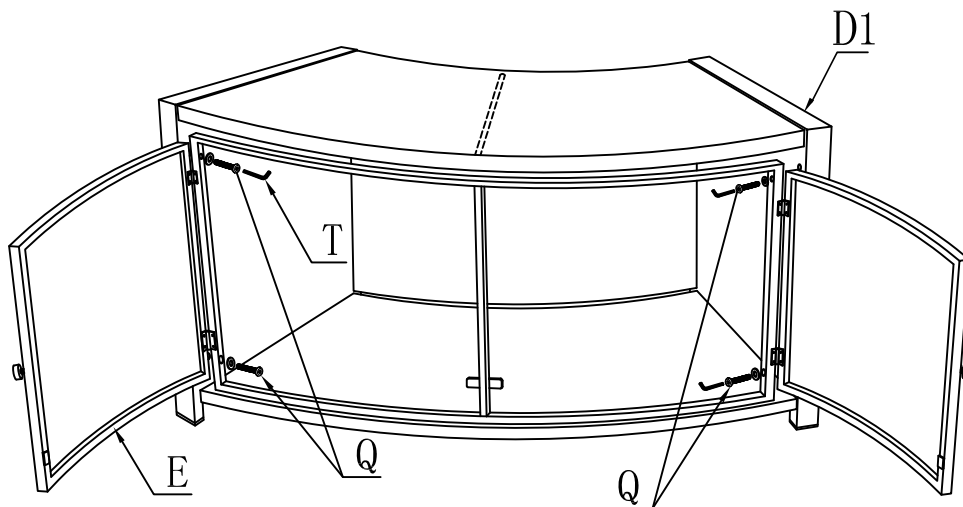

STEP4.

- A3 x2
- B1 x2
- Q x8

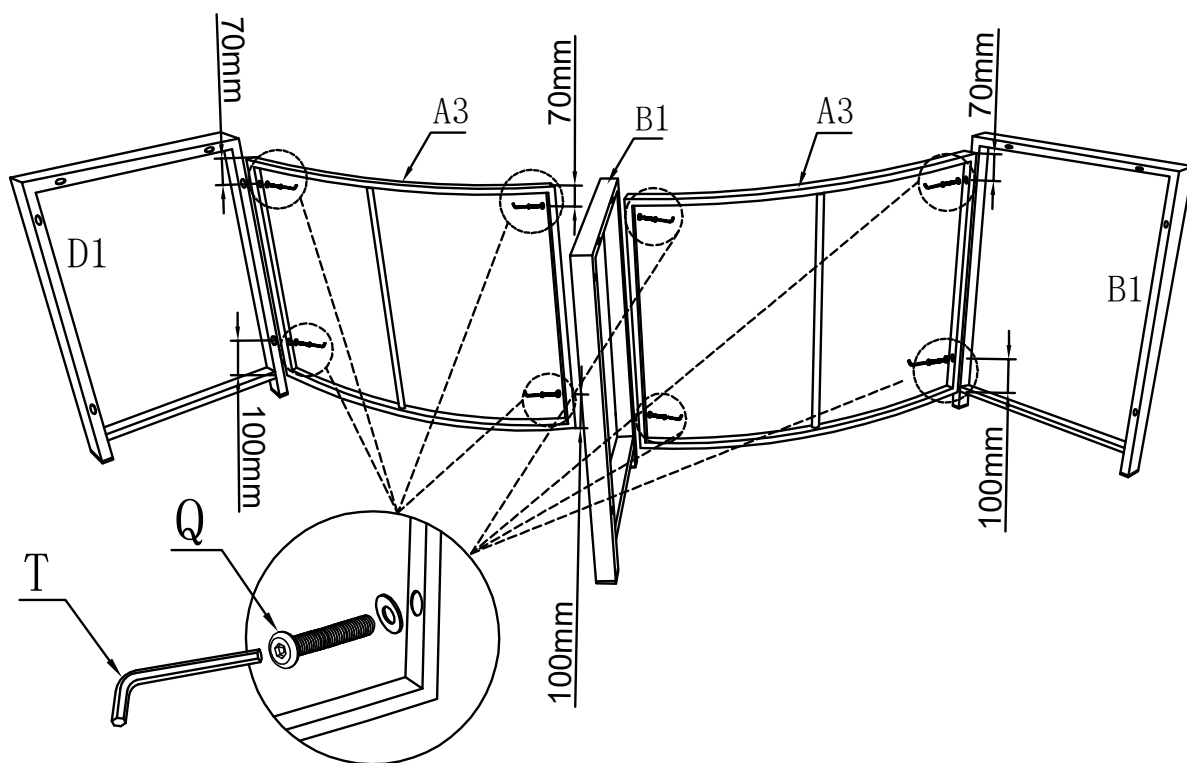

STEP5.

- G1 x1
- G2 x1
- H x1
- Q x8

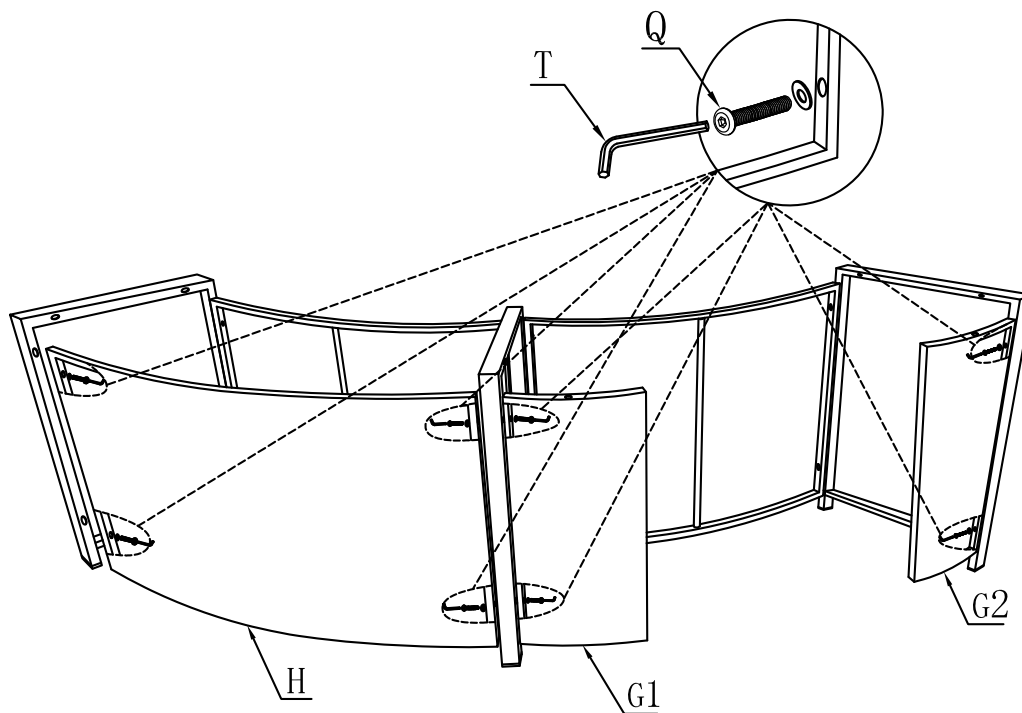

STEP6.

- F x1
- U x1
- Q x10

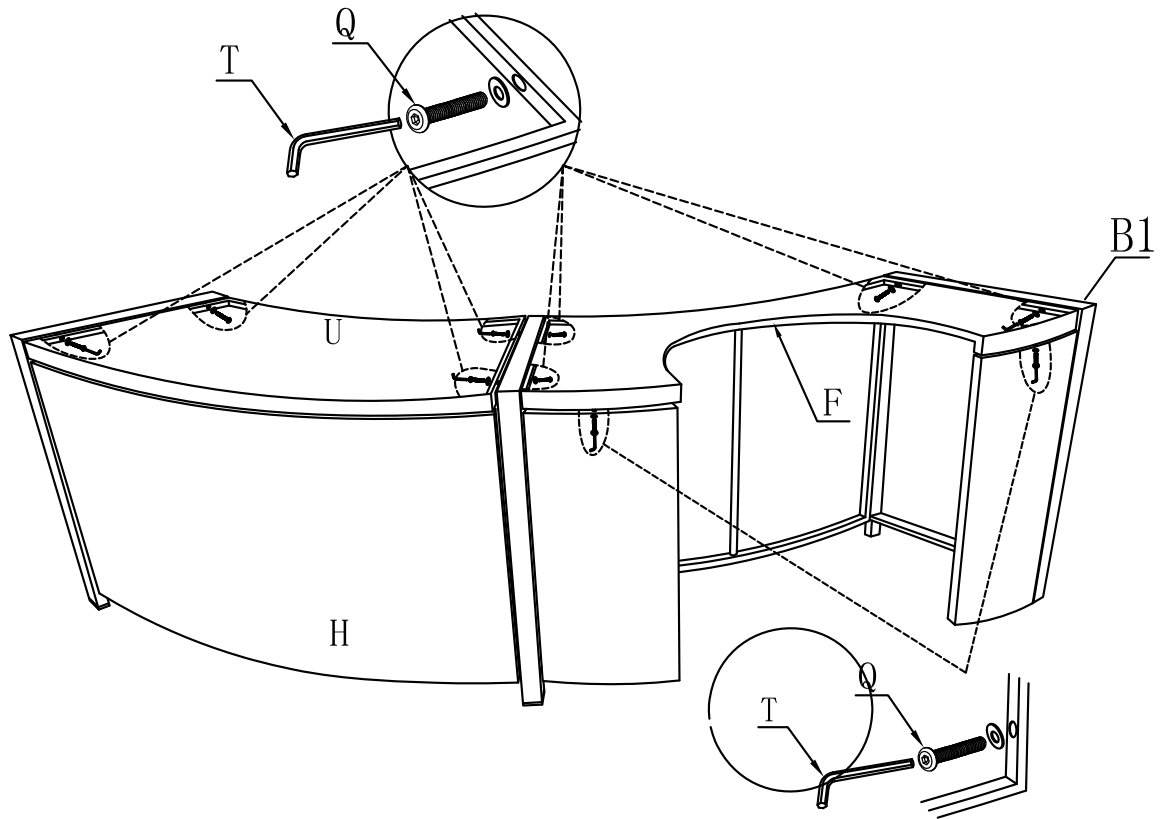

STEP7.

- A2 x1
- A3 x1
- B2 x1
- B3 x1
- Q x12

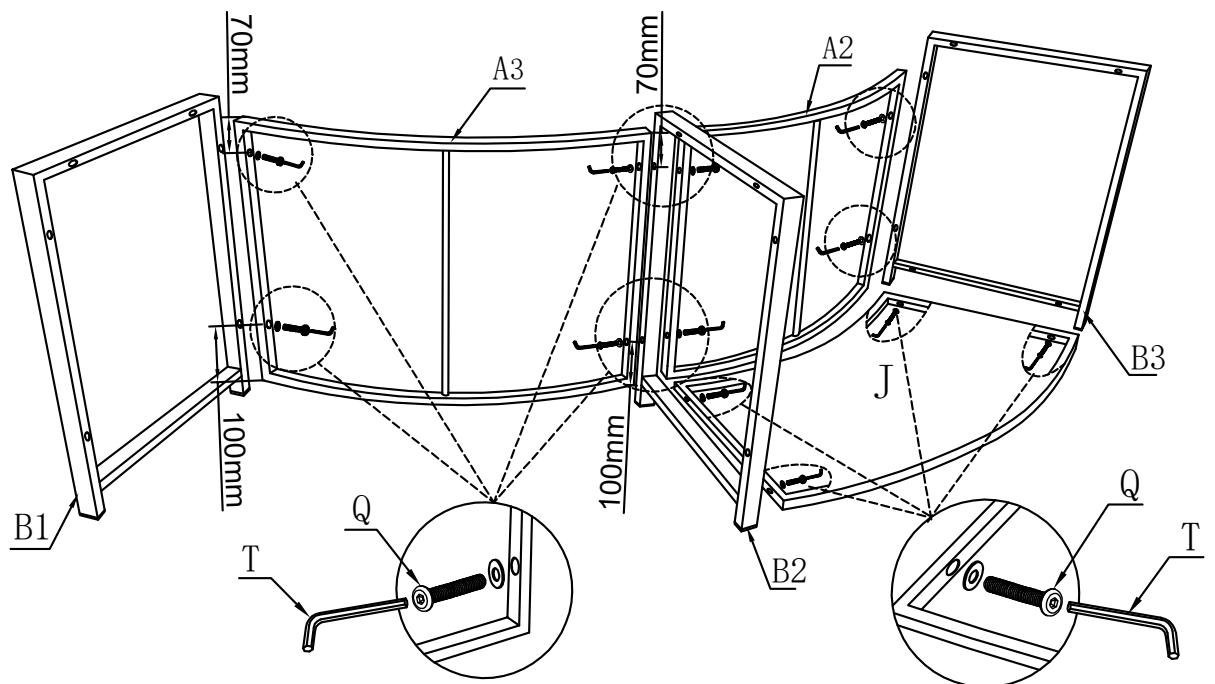

STEP8.

H x1
Q x4

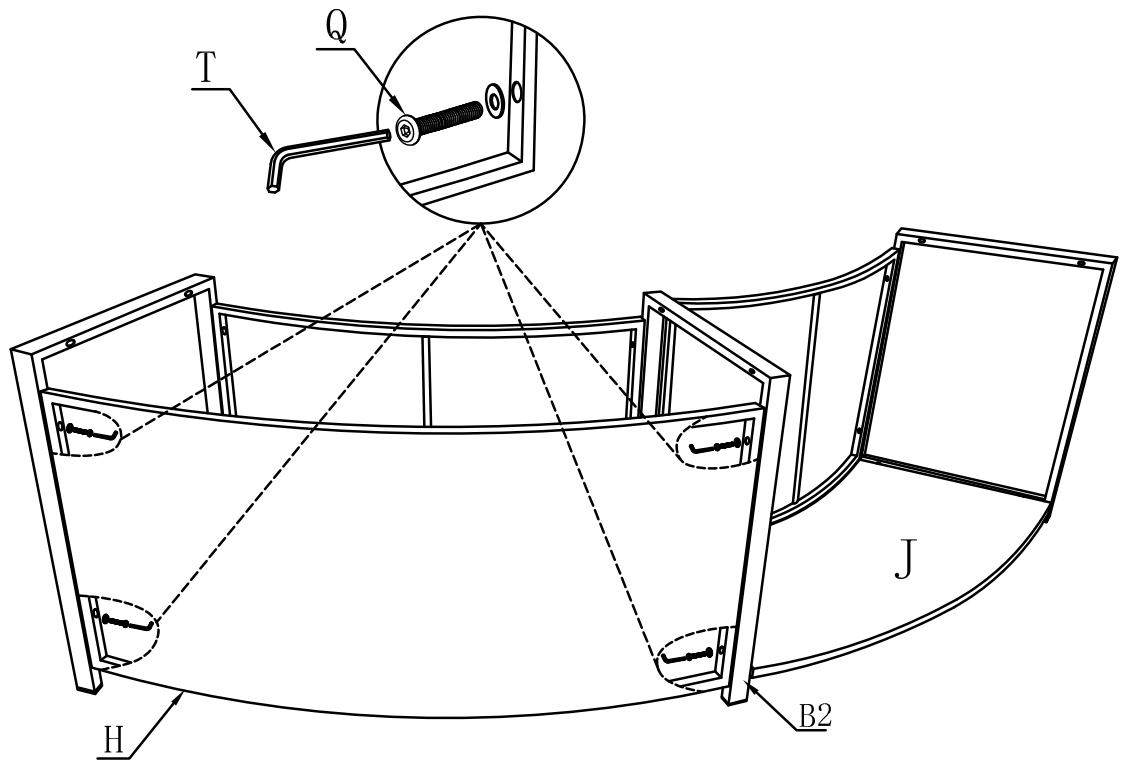

STEP9.

U x2
Q x8

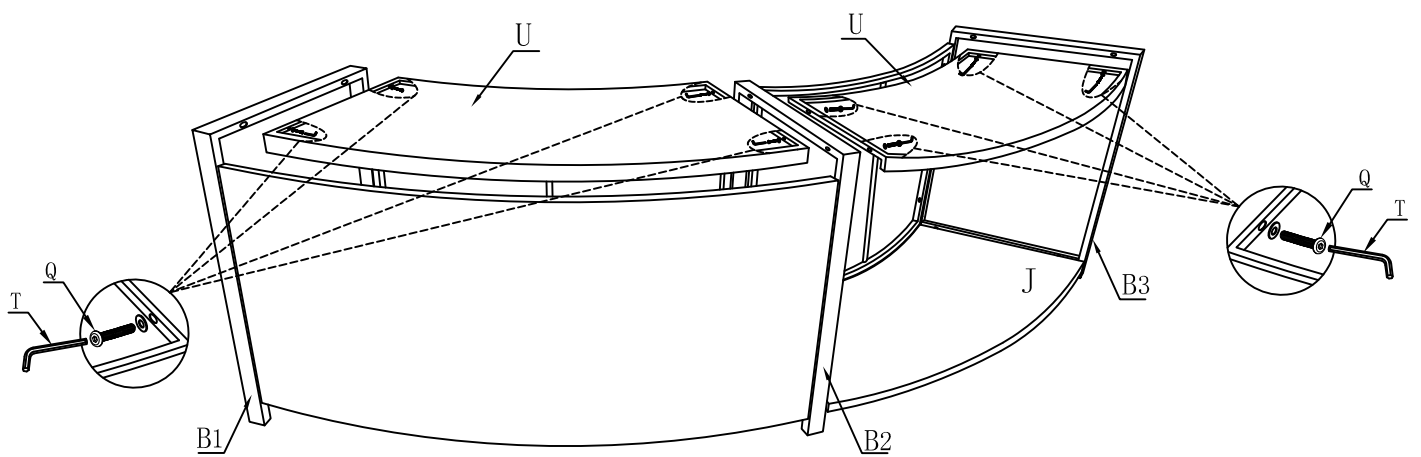

STEP10.

- A2 x1
- D2 x1
- J x1
- Q x8

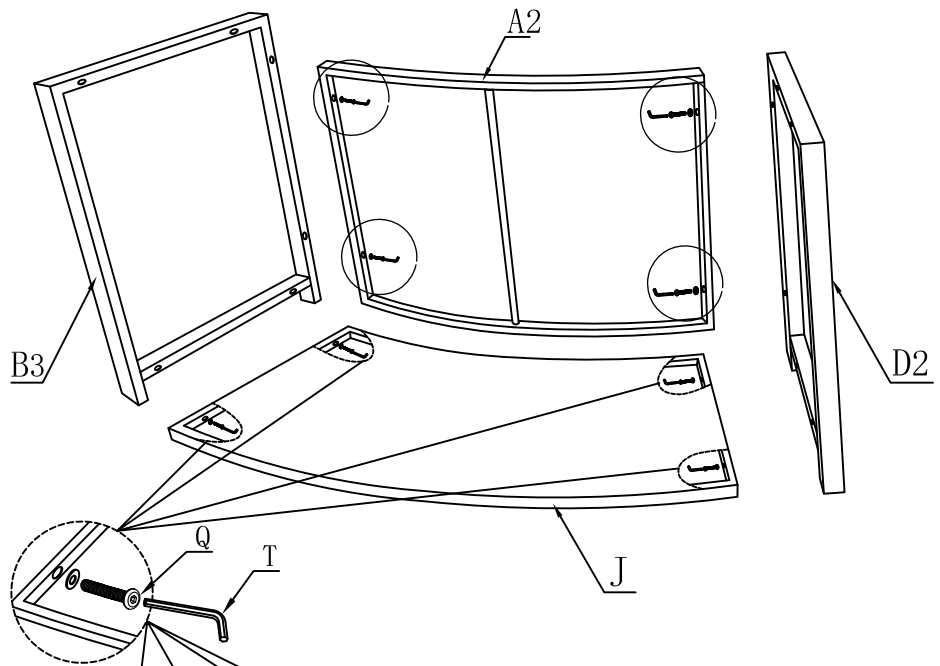

STEP11.

- U x1
- Q x4

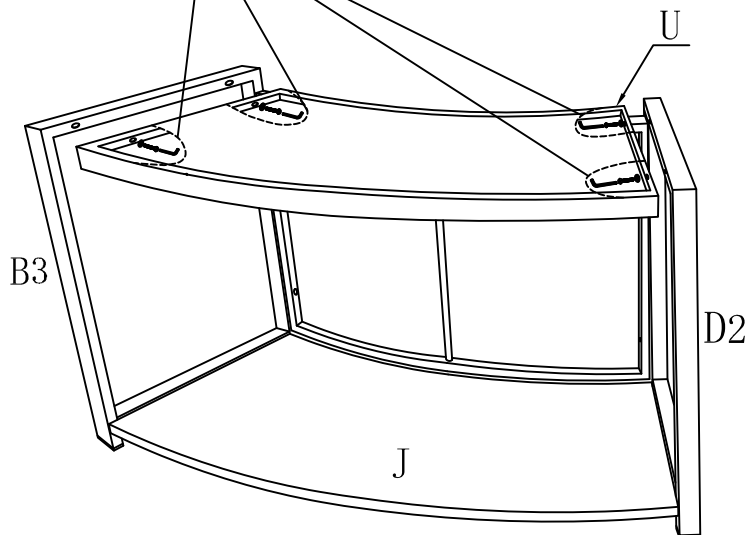

STEP12.

- M x1
- N1 x1
- P1 x1
- Q x4

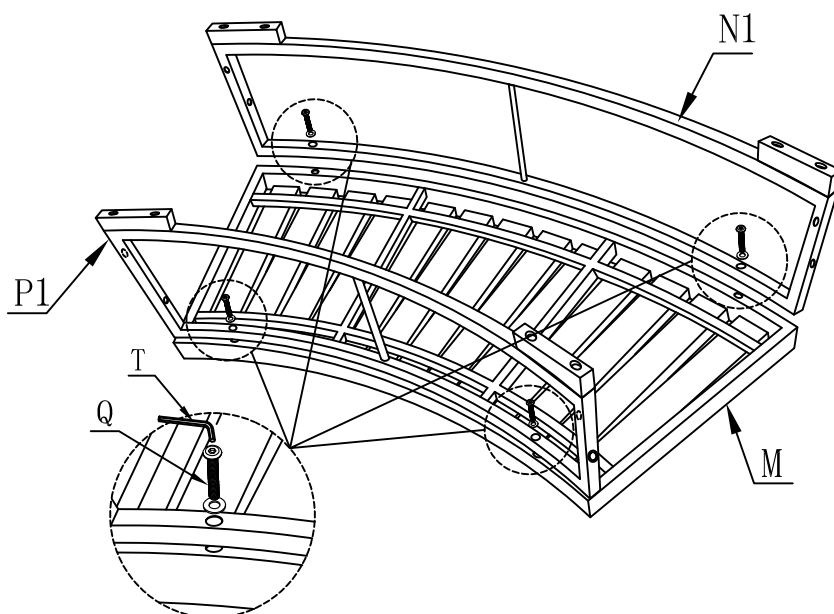

STEP13.

I x2
O x4

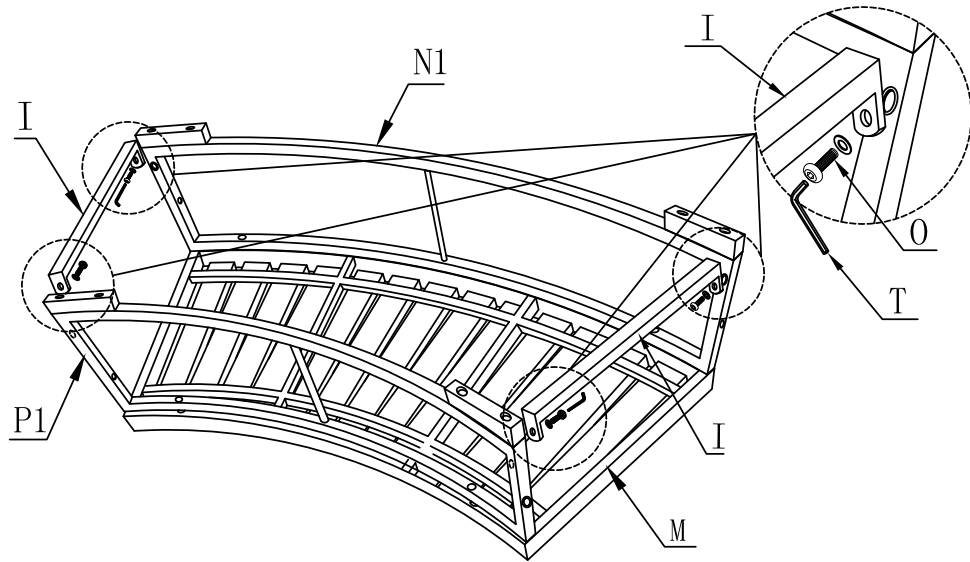

STEP14.

Q x2

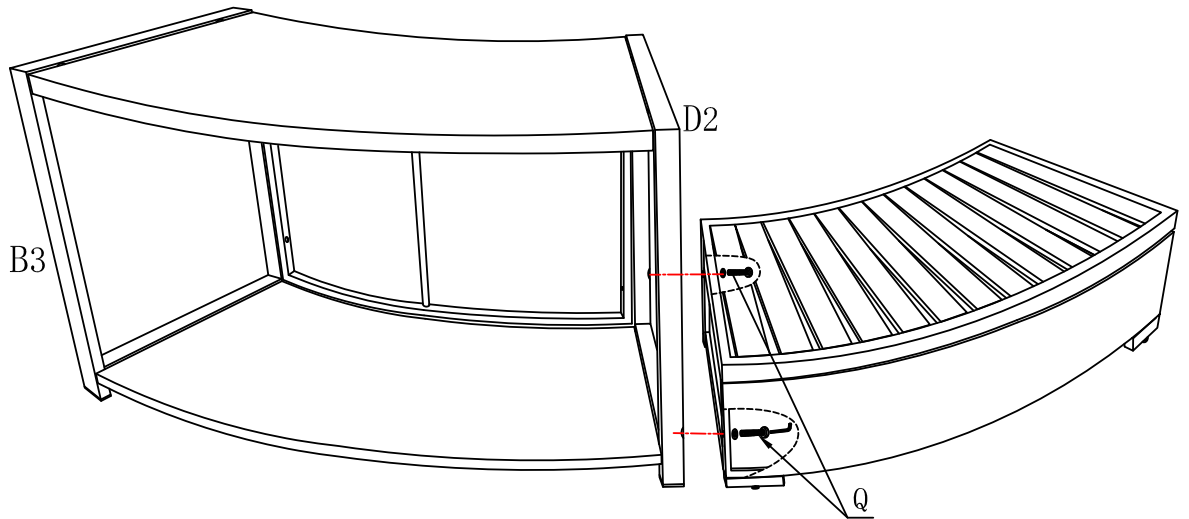

STEP15.

M x1
N2 x1
P2 x1
Q x4

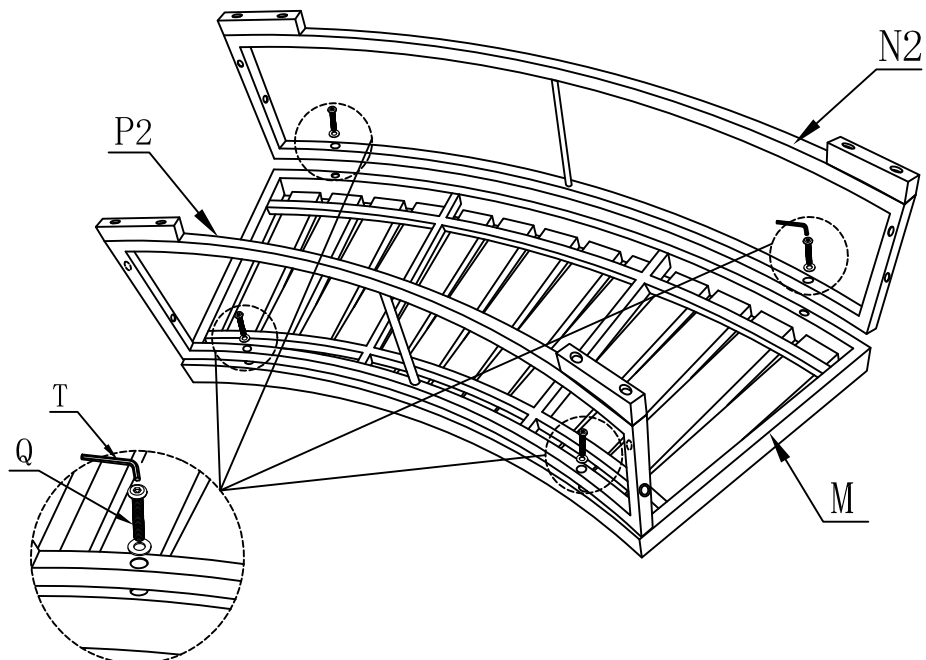

STEP16.

I x2
O x4

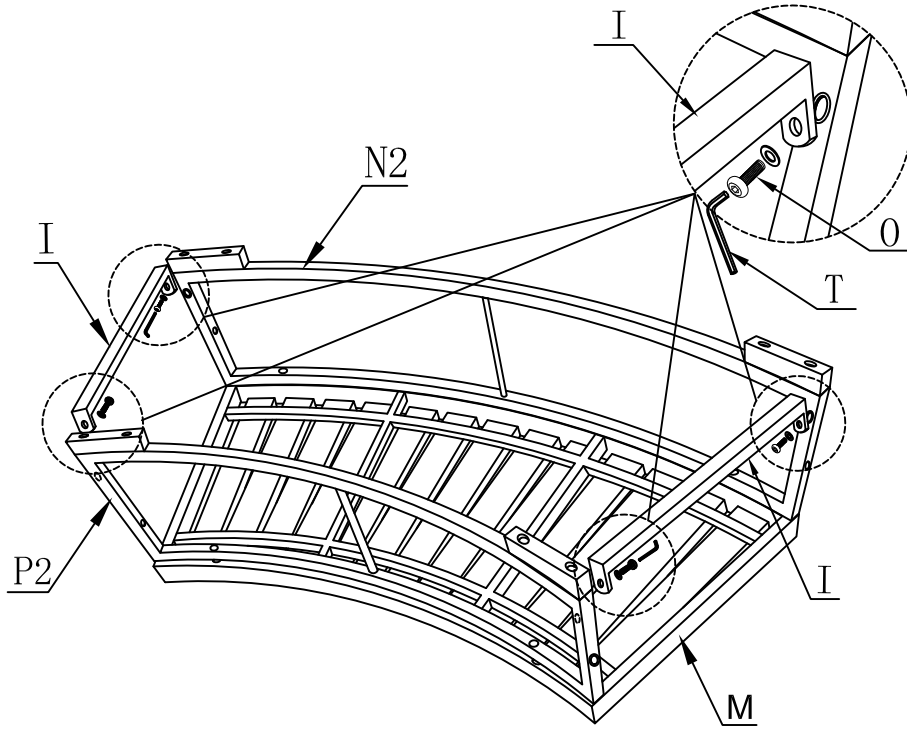

STEP17.

Q x2

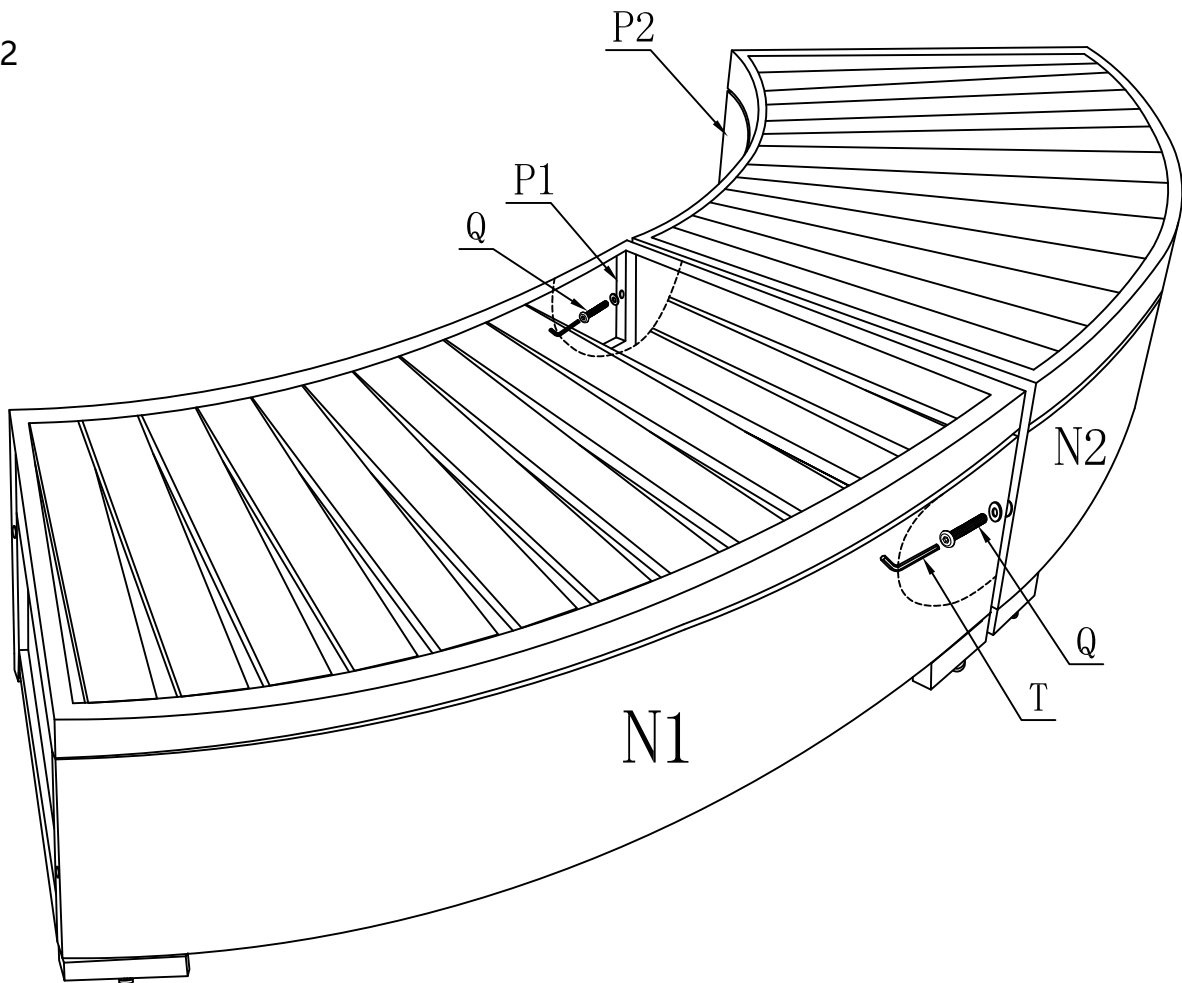

STEP18.

C2 x1
Q x2

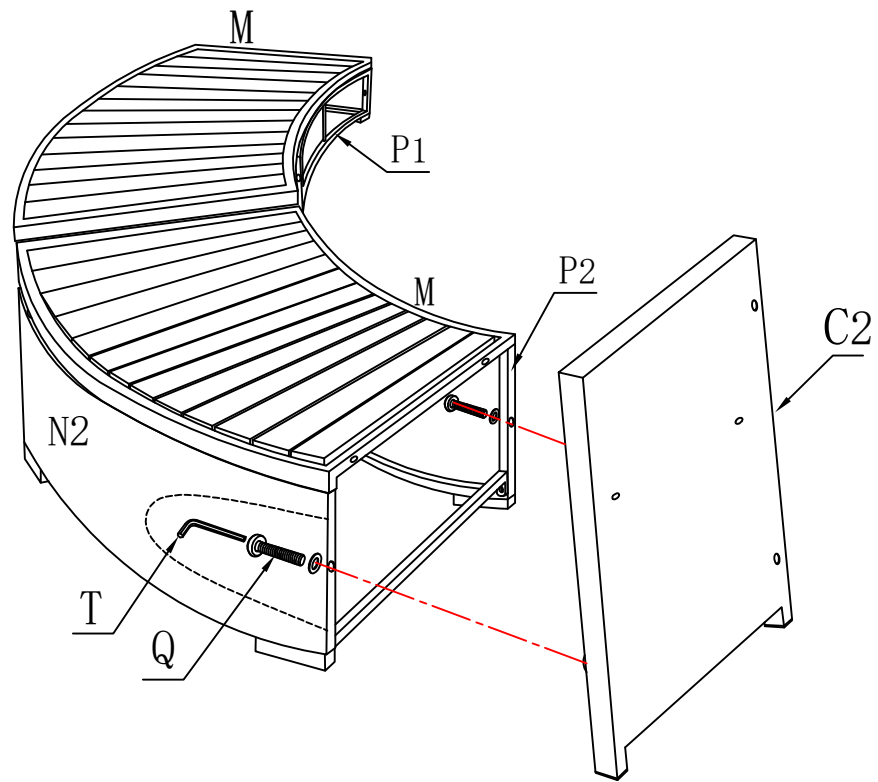

STEP19.

C1 x1
L x1
Q x4

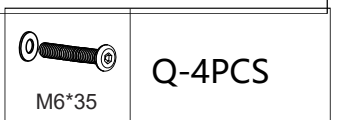
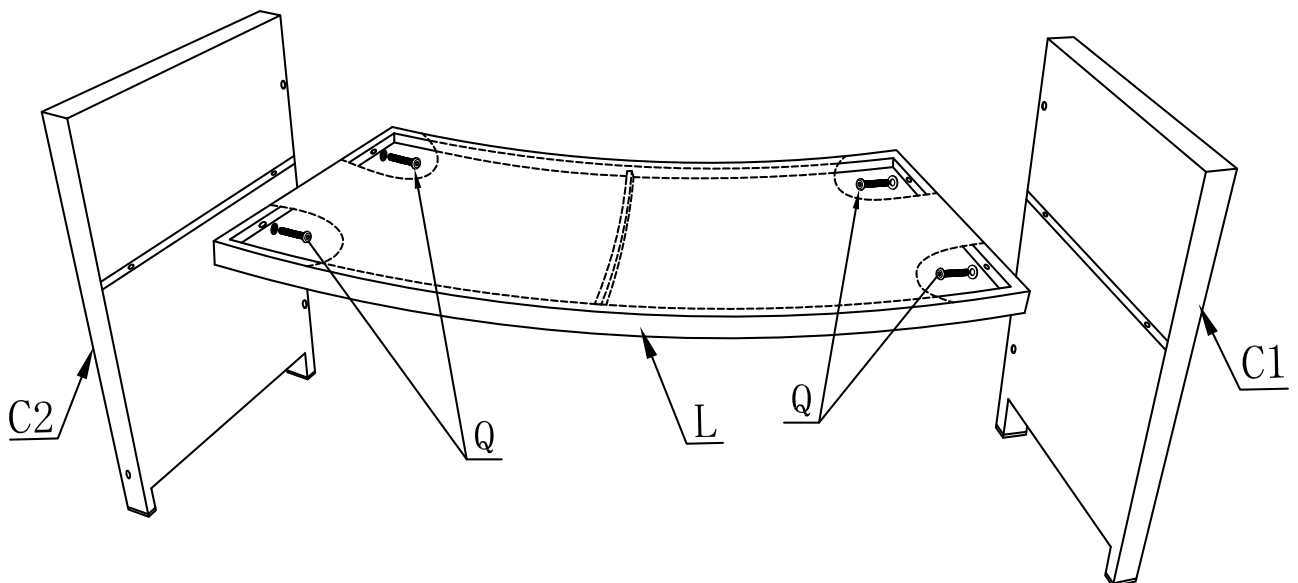

STEP20.

K x1
Q x4

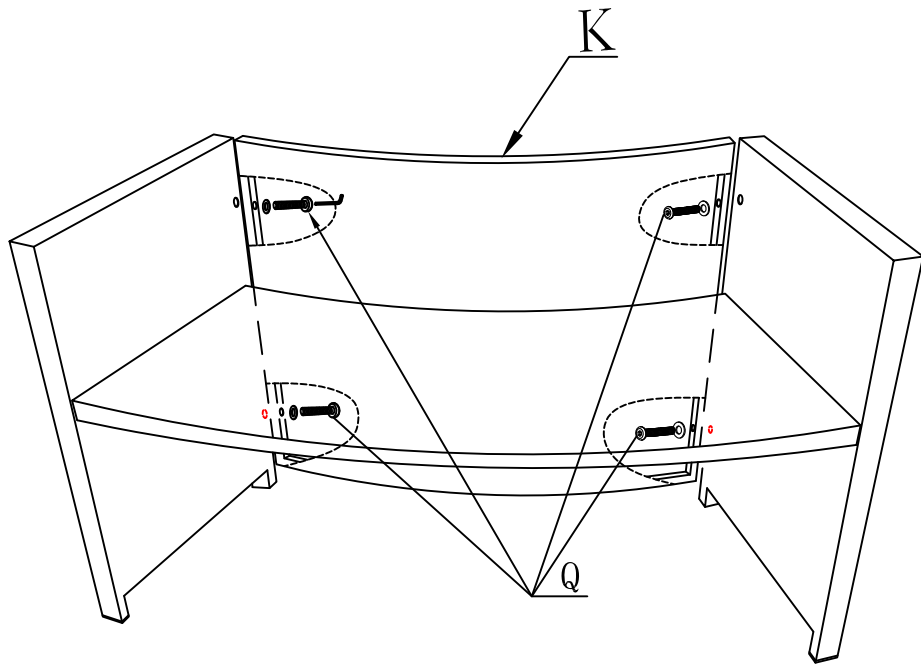

STEP21.

R x2
S x1

