

Montageanweisung / Installation instructions / Instruction de montage / Istruzioni di montaggio  
montagehandleiding / Instrukcja montażu / Montaj talimatlar / Osszeszerelési útmutató / Nàvod k montáži /  
Nàvod na montaž / Instrucțiune de montaj / Инструкция по монтажу / Montaj talimatina / Monteringsanvisningar  
Upute za montažu / Instrucciones de Montaje / Navodila za montažo

# INFINITY 2.0 CITY

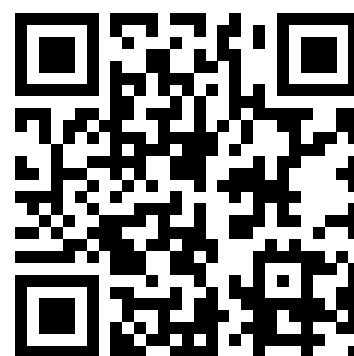
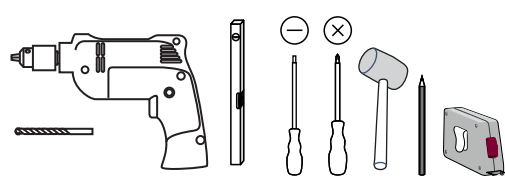
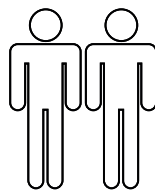
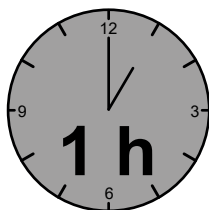

LC S.p.A  
Via del Piano s.n  
61030 Isola del Piano (PU)  
Italia  
<http://www.lcmobili.com/>

**D** – bitte lesen sie diese montageanleitung gut durch,  
Da wir für fehler, die durch falsche montage entstehen,  
Keine haftung übernehmen!

**Gb** – please read these installation instructions  
Through carefully as we cannot accept any liability  
For faults occurring as a result of incorrect installation!

**Cz** – přečtete si prosim pozorně tento návod k montáži,  
Aby jste předešli chybám vzniklých špatnou montáží,  
Za které neručíme!

**F** – veuillez lire attentivement cette notice de montage,  
Car nous déclinons toute responsabilité en cas d'erreurs  
Découlant d'un montage erroné !

**I** – prego leggere attentamente le istruzioni per il montaggio,  
Poiché decliniamo qualsiasi responsabilità  
Per difetti derivanti da montaggio errato.

**S** - läs monteringsanvisningarna noggrant.  
Vi avsäger oss allt ansvar för defekter som  
Uppstår p.g.a. Felaktig montering.

**Hr** – pažljivo pročitajte upute za montažu,  
Jer otklanjamo svaku odgovornost za pogreške  
Nastale uslijed pogrešne montaže.

**Slo** – prosimo, da pozorno preberete navodila za montažo,  
Saj zavračamo vsakršno odgovornost za napake,  
Ki bi nastale zaradi napačne montaže.

**Nl** – leest u alstublieft deze montagehandleiding goed door,  
Voor fouten door verkeerde montage zijn wij niet verantwoordelijk.

**Pl** – prosze uwaznie zapoznac sie z instrukcja montazu,  
Poniewaz nie ponosimy odpowiedzialnosci za niewlasciwy montaz.

**HU** – Kérjük, olvassa el figyelmesen  
ezt az összeszerelési útmutatót,  
mert a helytelen összeszerelésből  
a dódó hibákért nem vállalunk felelősséget!

**SK** – Prosime, dobre prečítajte si tento návod na montáž,  
pretože nepreberáme žiadne ručenie za chyby,  
ktoré vzniknú na základe chybnej montáže!

**RO** – Vă rugăm să cititi cu atenție aceste instrucțiuni  
de montaj deoarece nu preluăm garanția pentru defecte  
ce apar datorită unui montaj incorect!

**RUS** – Пожалуйста, внимательно ознакомьтесь ù  
с данной инструкцией по монтажу, поскольку мы не  
несем ответственности за ошибки, причиной которых  
является неправильный монтаж.

**TU** – İlkonce kullanma klavuzunu iyi okkuyun,  
yalnis montaj yapasaniz bunun sorumlusu biz degiliz.

**ES** – Se ruega leer con atención las instrucciones  
de montaje debido a que declinamos cualquier  
responsabilidad  
por defectos derivados de un montaje erróneo.

**ONDERDELEN LYST-SERVICEKARTE-FORMULAIRE DEMANDES SAV-SPAREPARTS LIST-SCHEDA DI SERVIZIO**  
**BESLAG-BESCHLAEGE - QUINCALLERIE - HARDWARE - FERRAMENTA**

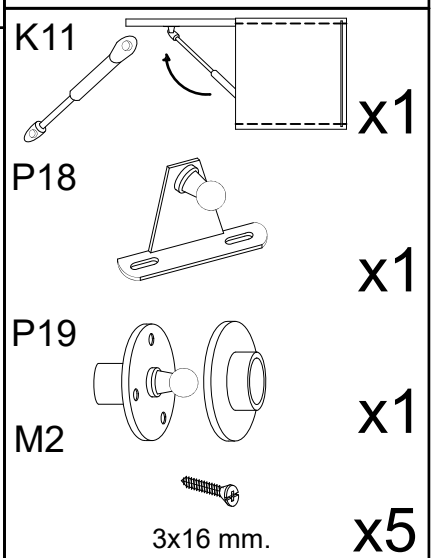
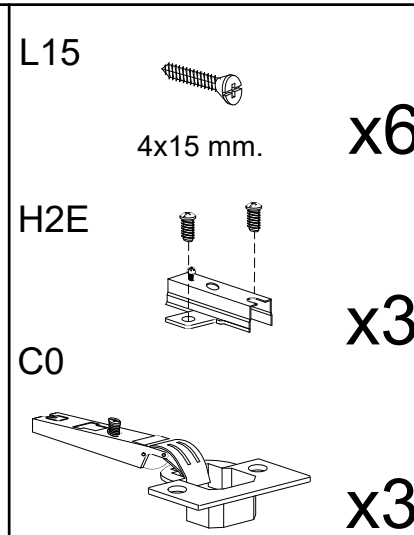
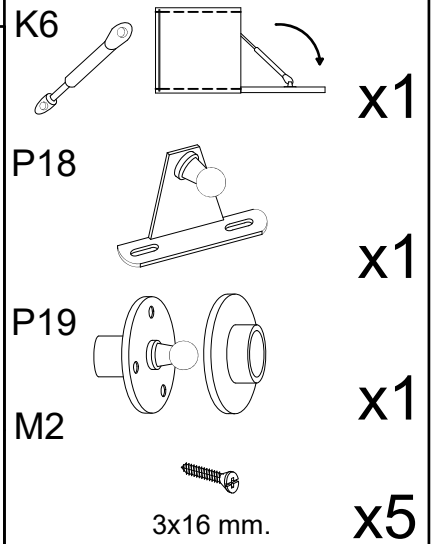
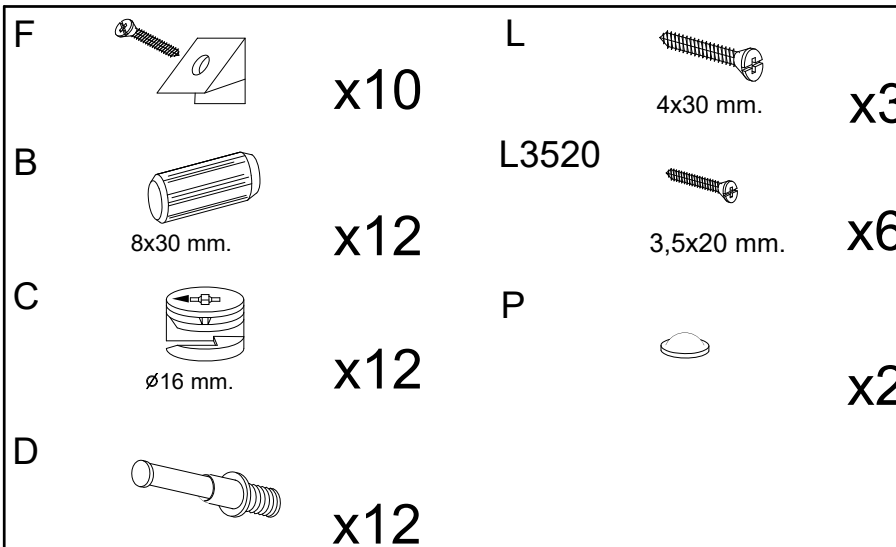
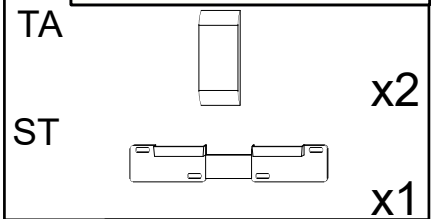
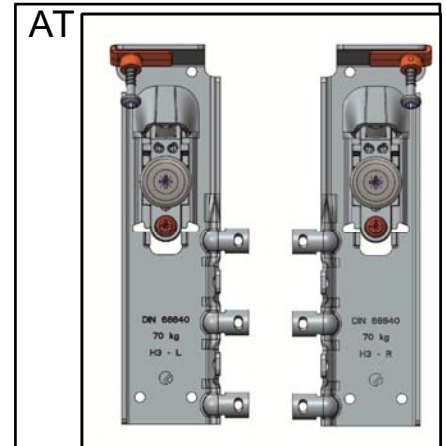
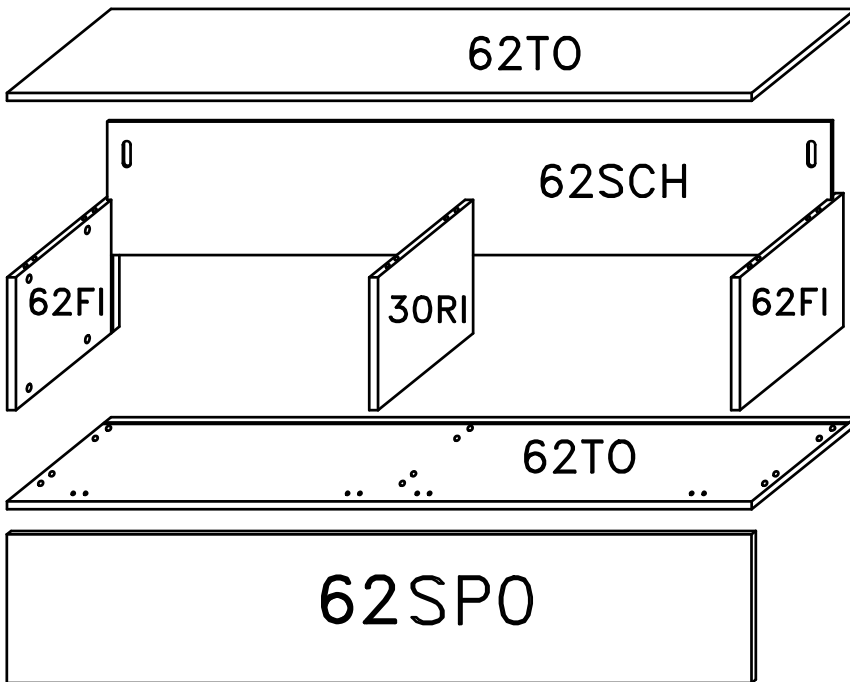

1

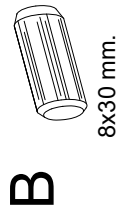
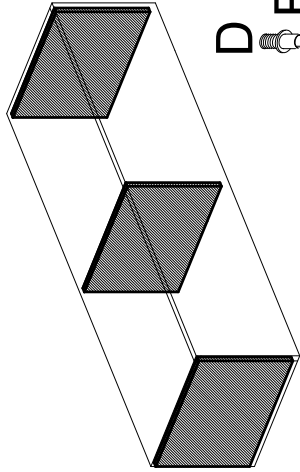

8x30 mm.

D

x12

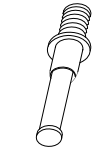

x12

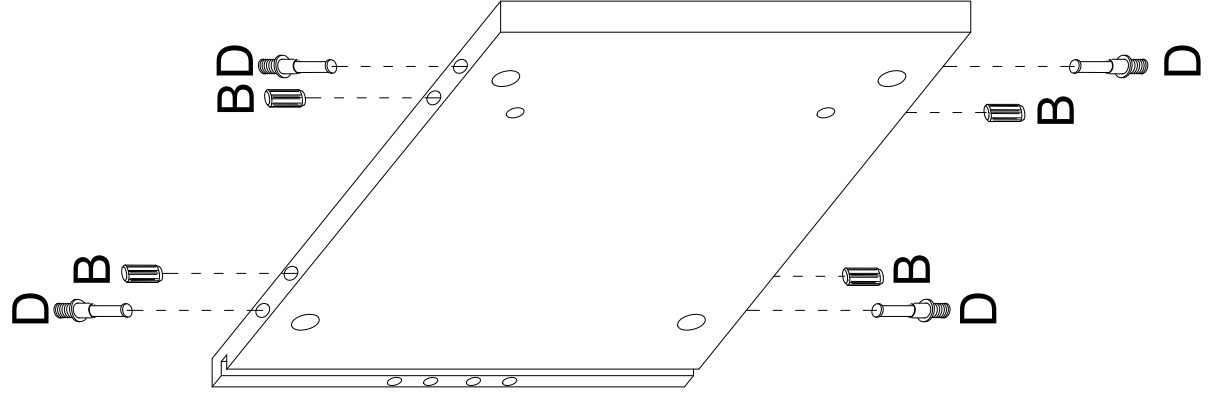
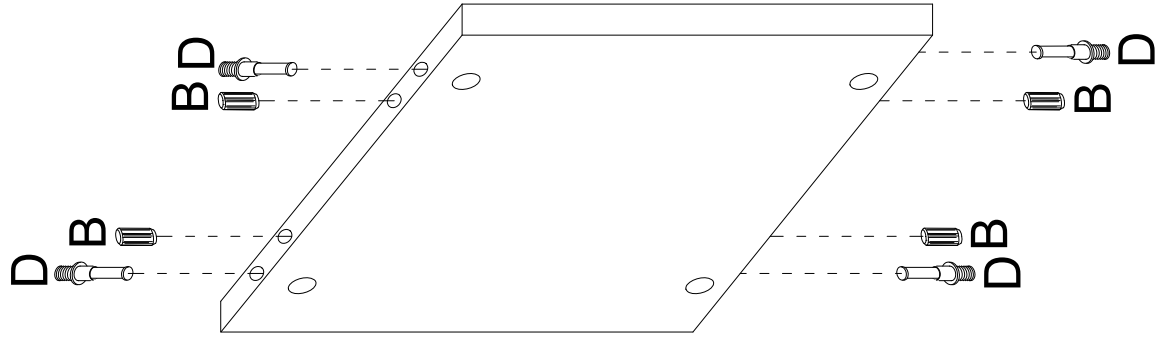
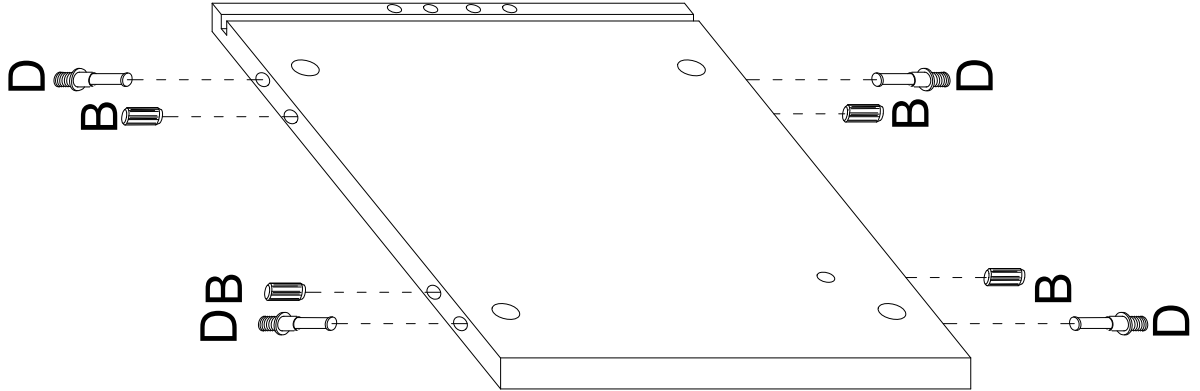

2

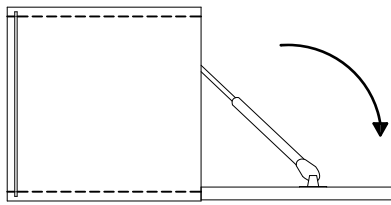

L 4x30 mm. x3

C  $\varnothing$ 16 mm. x12

M2 3x16 mm. x3

H2E

P19 x3

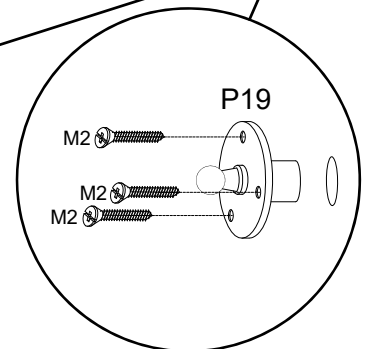
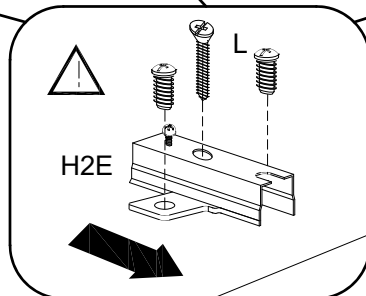
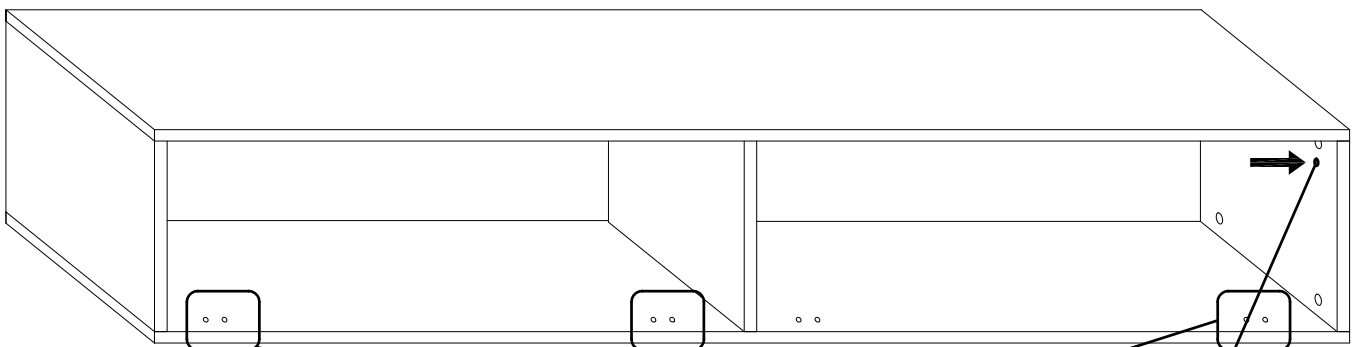
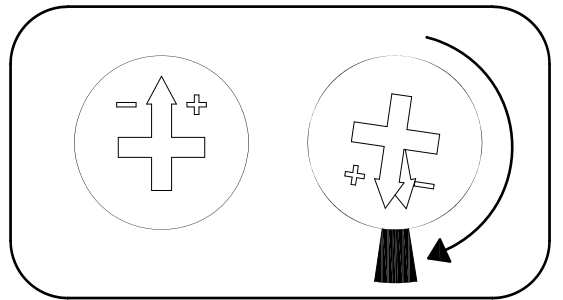
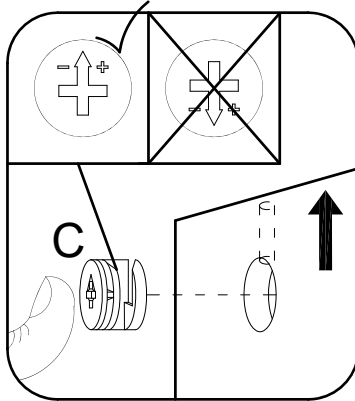
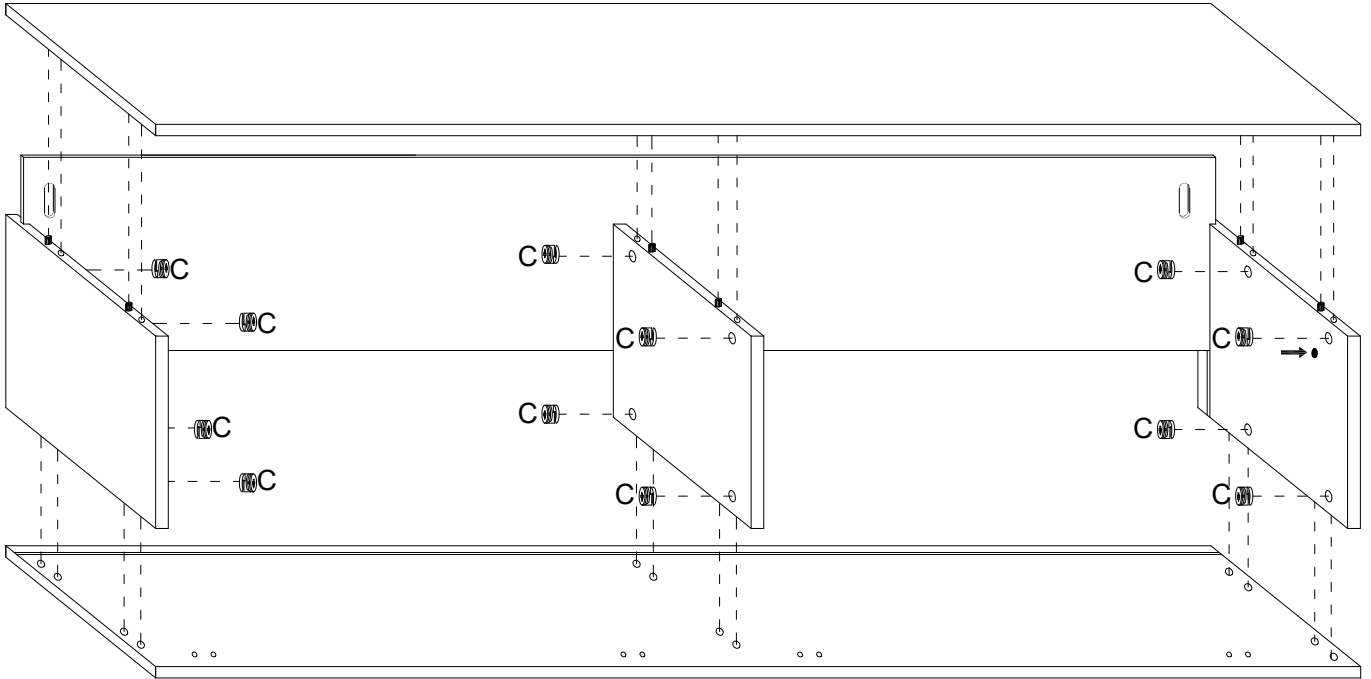
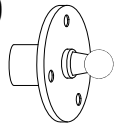
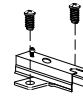



2

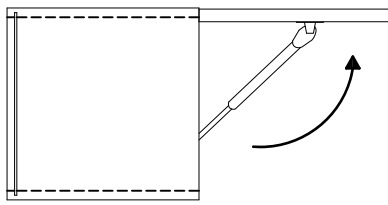

H2E

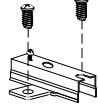

x3



C

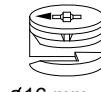

∅16 mm.

x12

M2

P19



4x30 mm.

x3

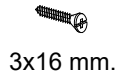

3x16 mm.

x3

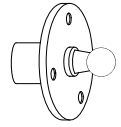

x1

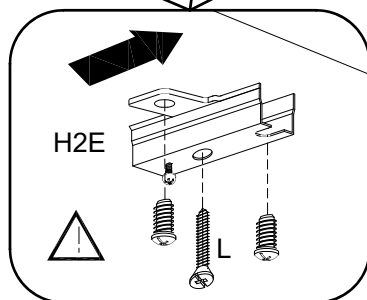
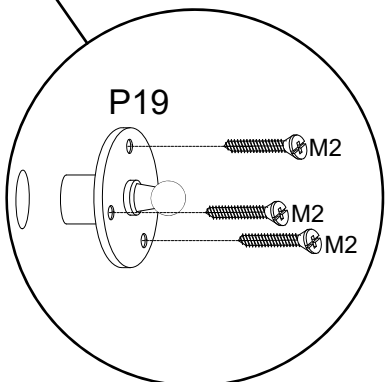
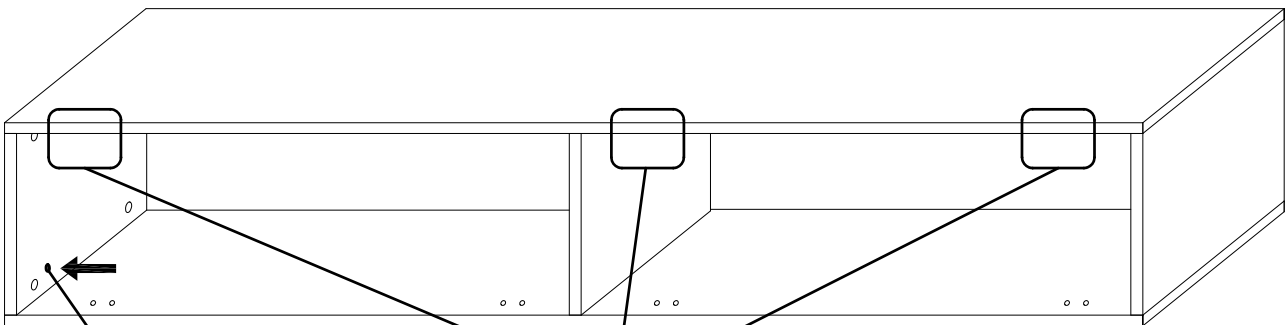
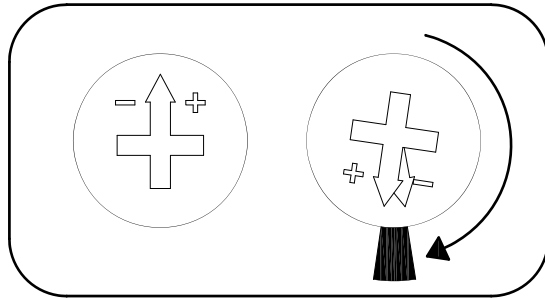
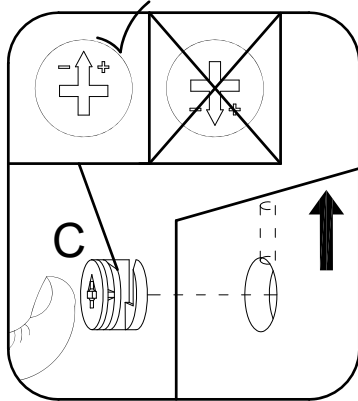
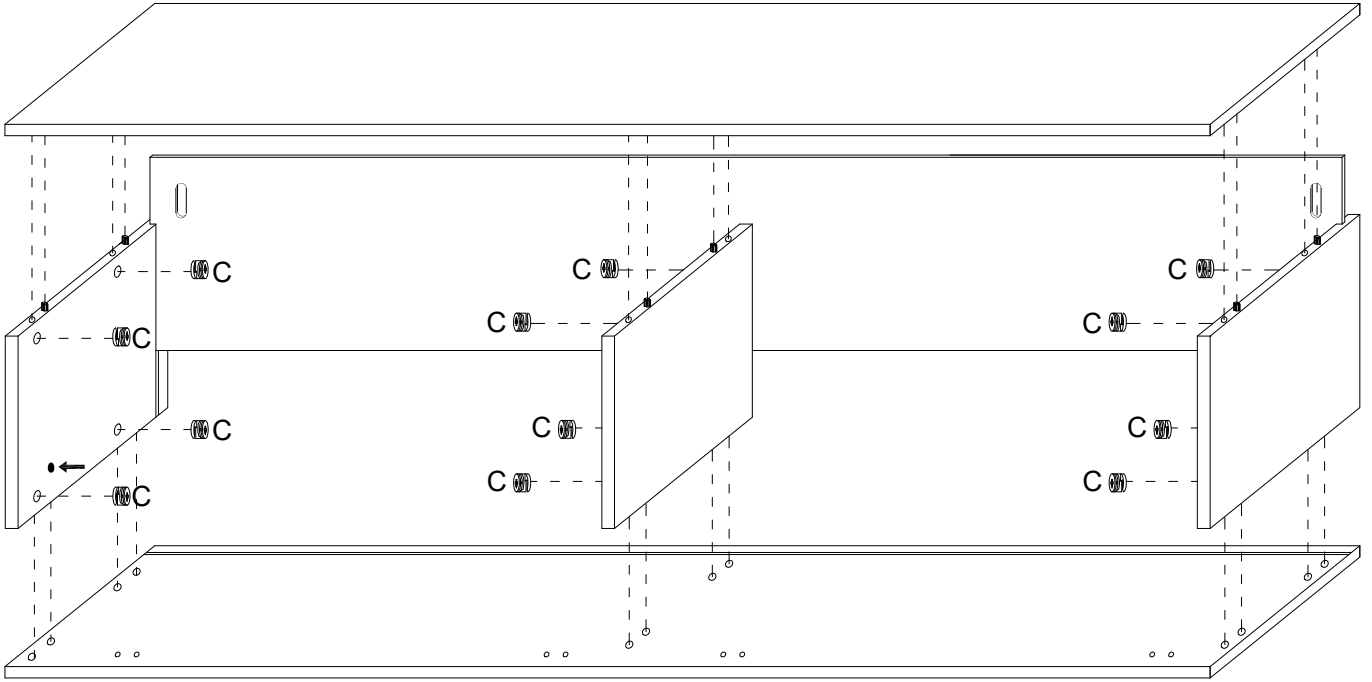

3

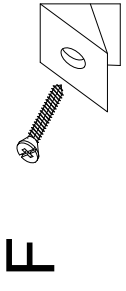

x10

L3520



x2

3,5x20 mm.

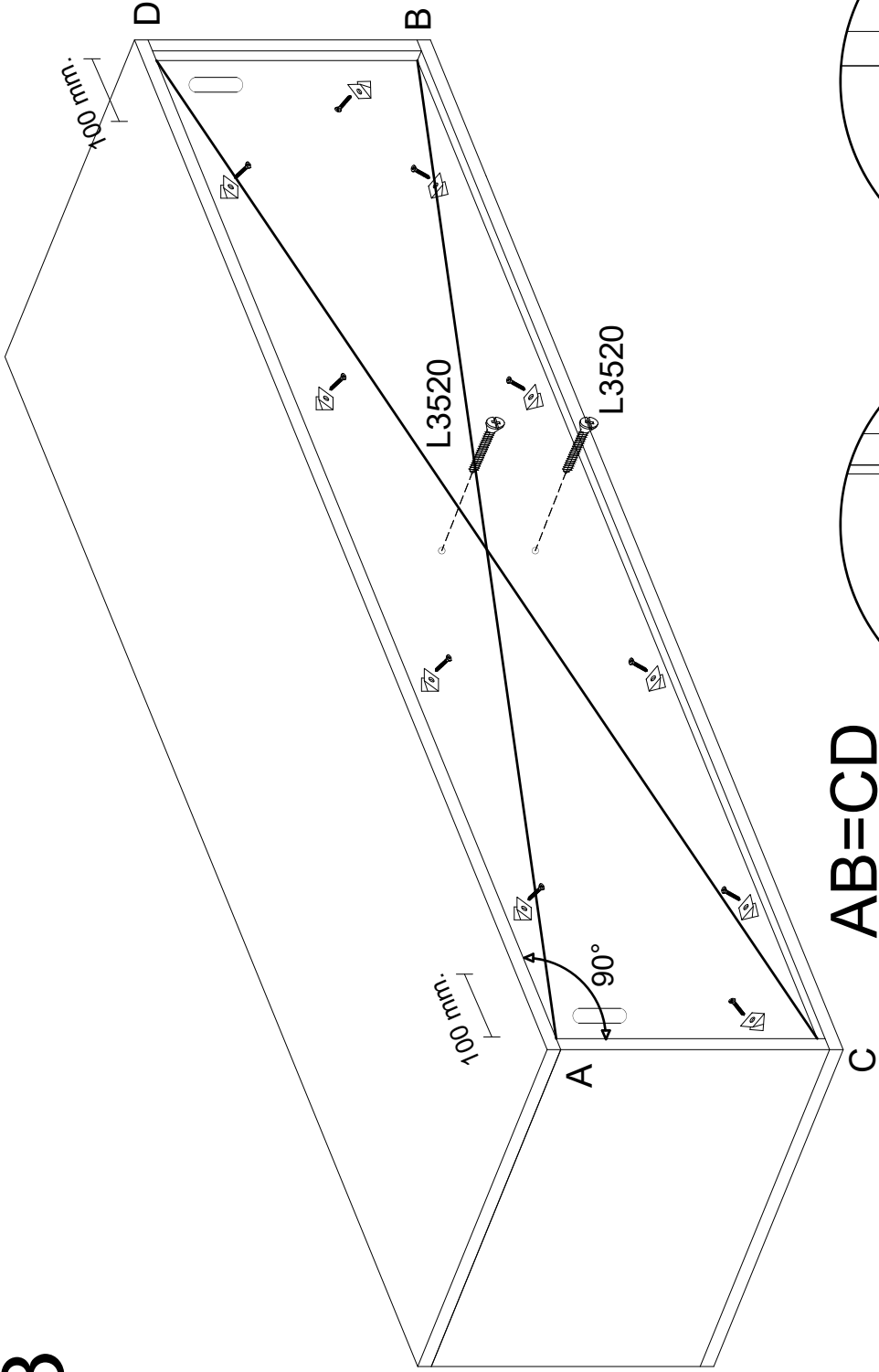

AB=CD

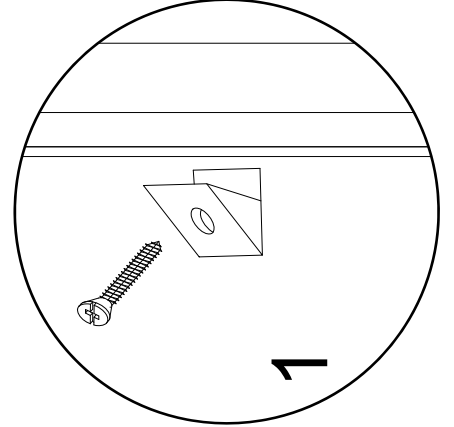

1

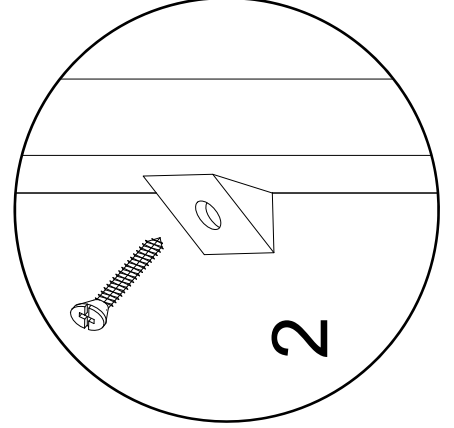

2

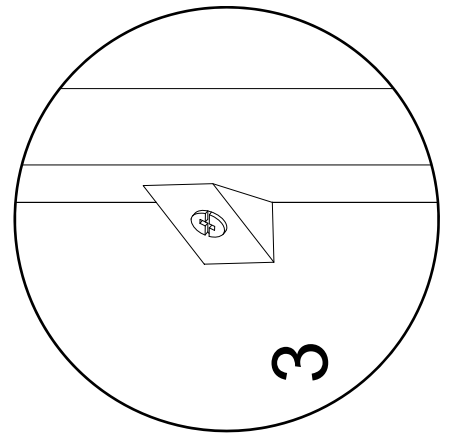

3

4

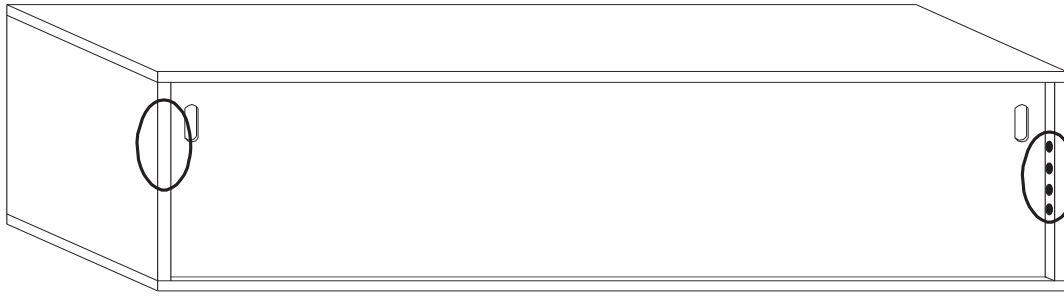

AT

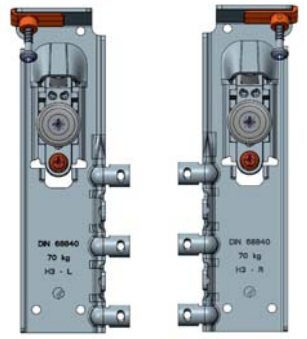

L3520



3,5x20 mm. X4

2

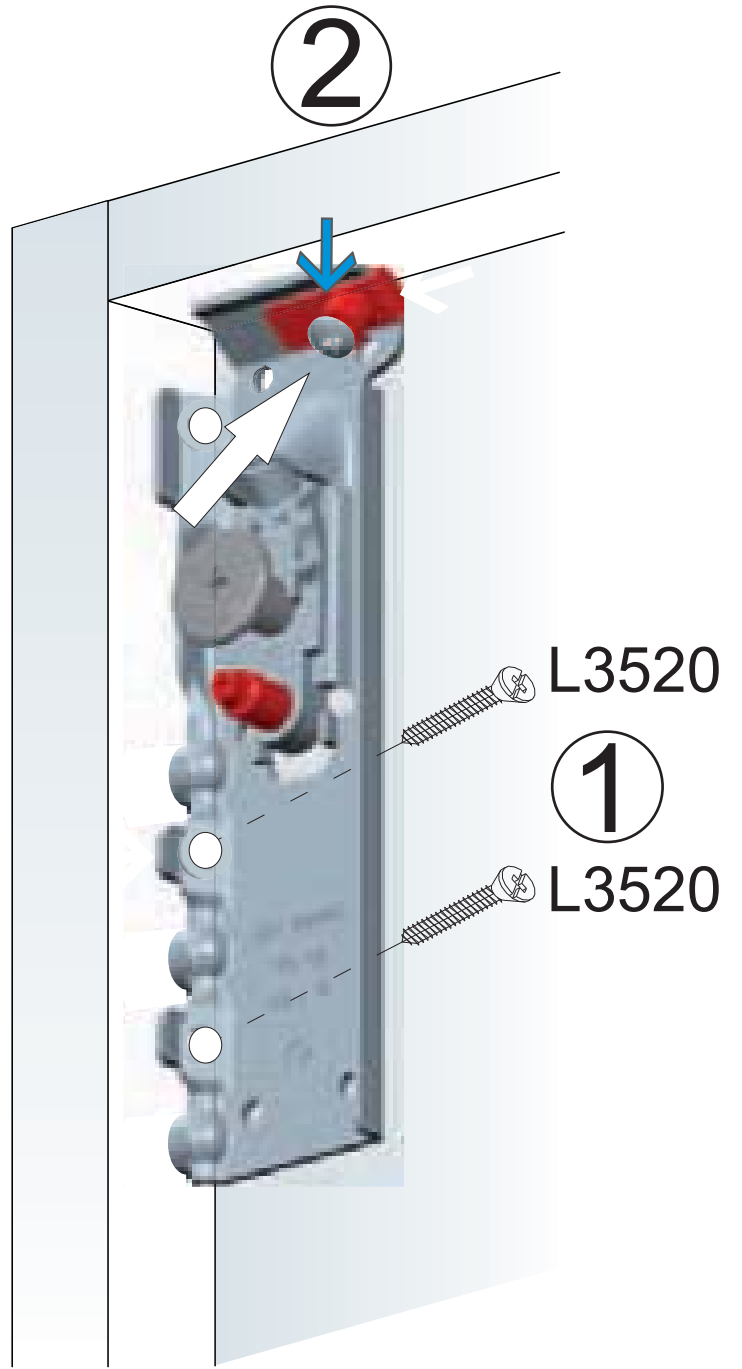
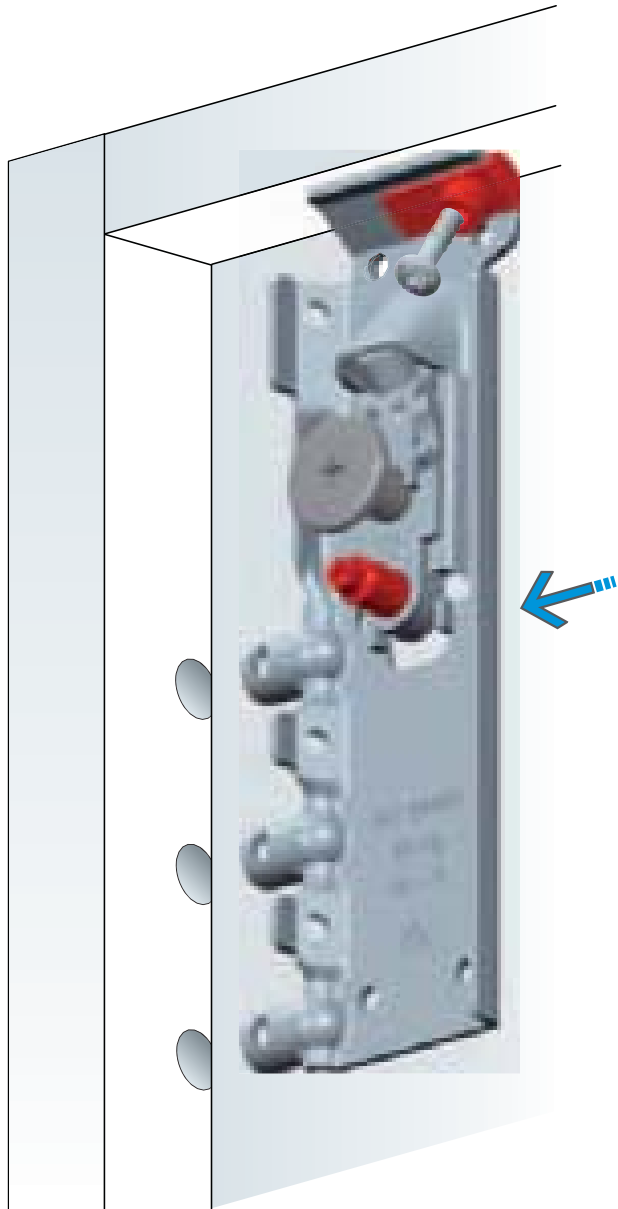

5



ST

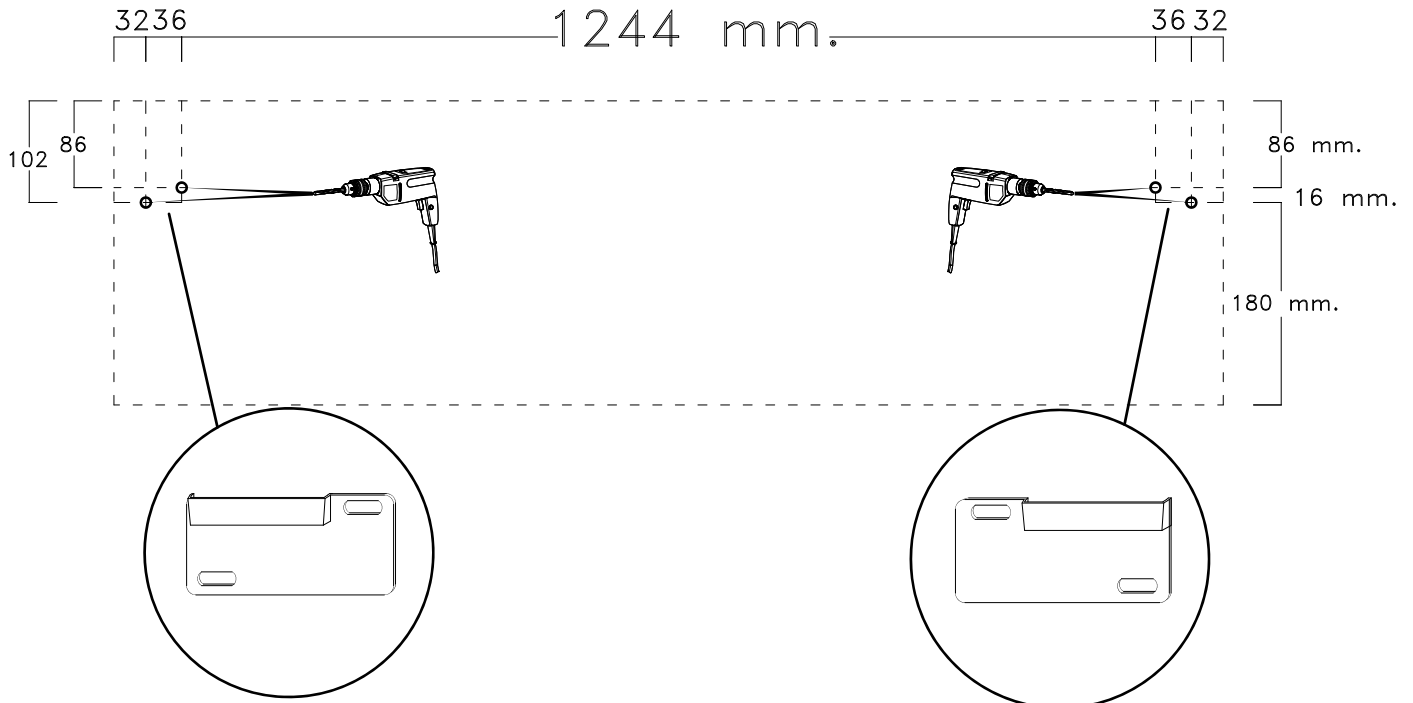
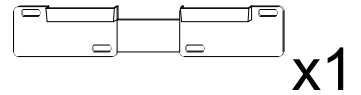

Gentile Cliente

Il montaggio dei pensili deve essere effettuato da personale competente. I tasselli di fissaggio non sono compresi nella ferramenta. Scegliere il tipo di tassello per il fissaggio più adatto alla tipologia di muro. Assicurarsi l'idoneità della parete per un sostegno sicuro del pensile.

Dear Customer,

The assembling of the hanging elements must be done by a competent staff. The wall plugs are not included in the hardware package. Choose the wall plugs more suitable to the type of the wall. Ensure the suitability of the wall for a secure support of the hanging element.

Sehr geehrter Kunde, die Montage der Hängeelemente muss von Fachpersonal ausgeführt werden!

Bitte verwenden Sie eigene Dübel, die der Beschaffenheit der Wand entsprechen. Zu Ihrer eigenen Sicherheit legen wir dem Beschlagbeutel keine Dübel bei.

Cher client, les éléments muraux ne peuvent être installés que par du personnel qualifié !

Veuillez utiliser vos propres ancrages adaptés à la nature du mur. Pour votre sécurité, nous n'incluons pas de chevilles dans le matériel.

Estimado cliente, el montaje de los muebles colgados en la pared debe ser realizado por personal competente. Los tacos de fijación no están incluidos en la bolsa de herrajes. Elija el tipo de anclaje de fijación que mejor se adapte al tipo de pared. Asegúrese de que la pared sea adecuada para un soporte seguro del mueble colgado en la pared.

6

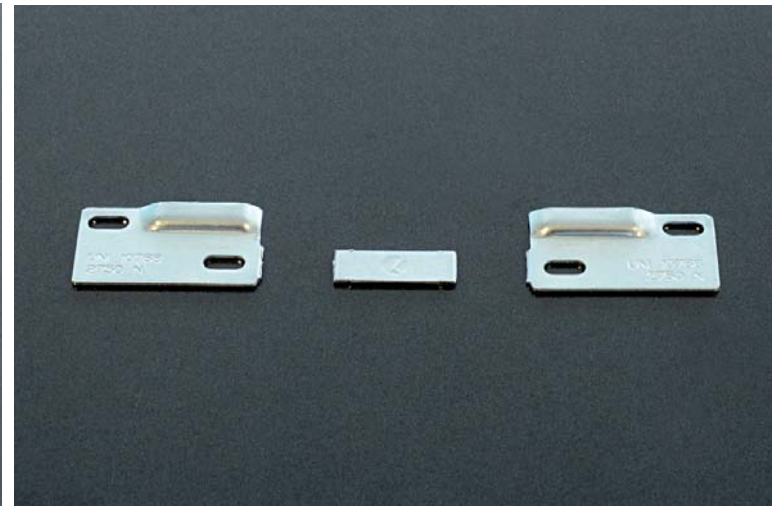
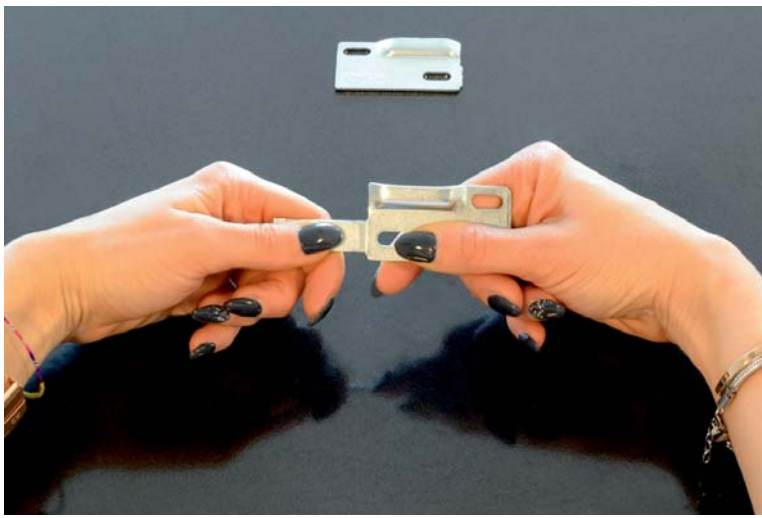
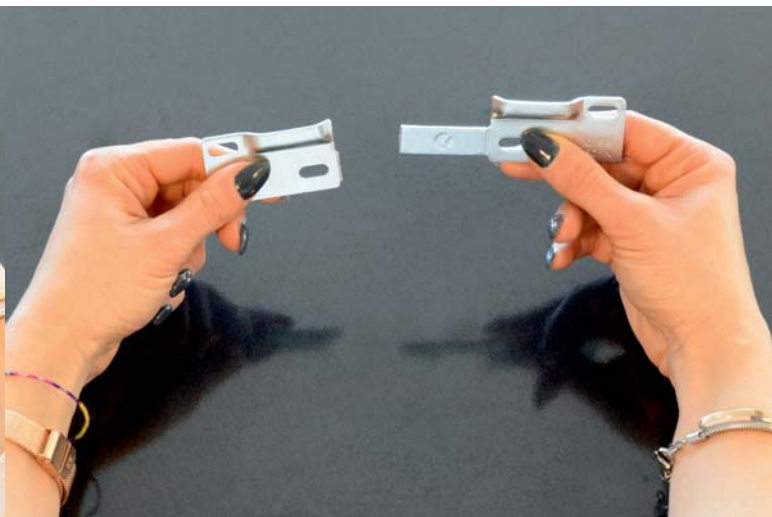
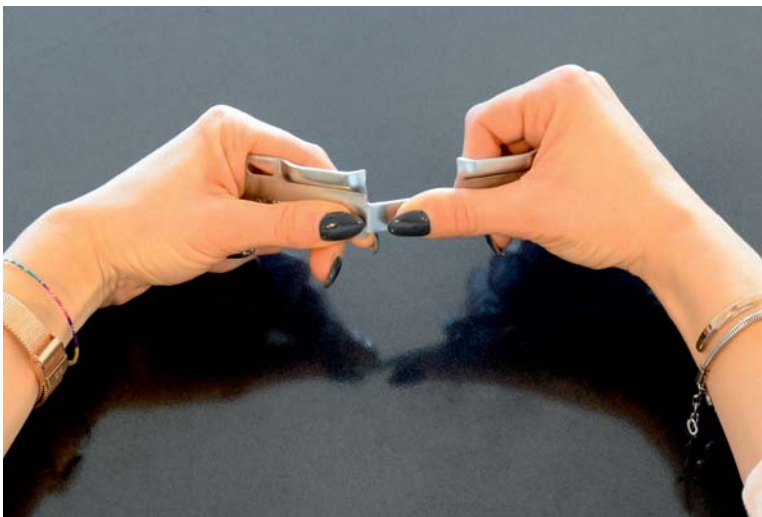
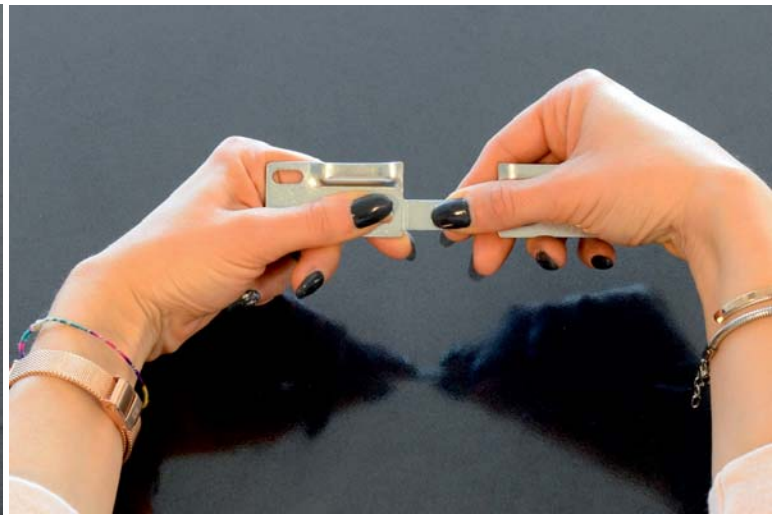
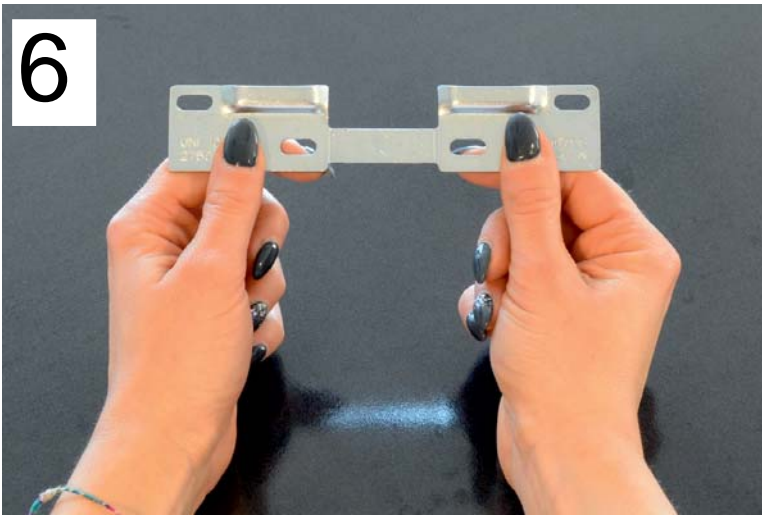

7

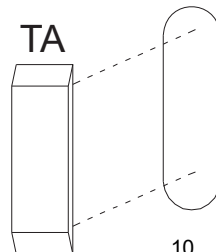
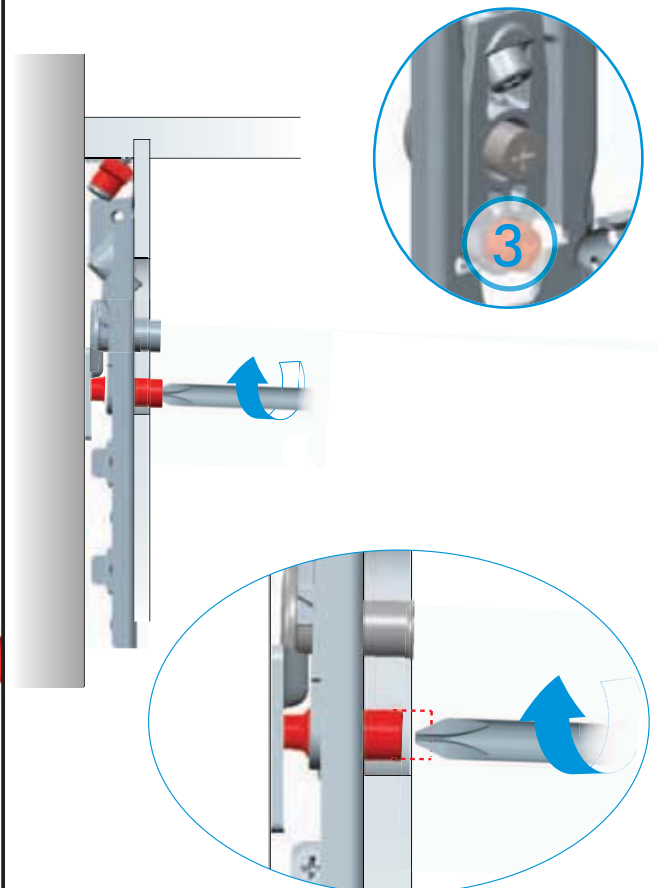
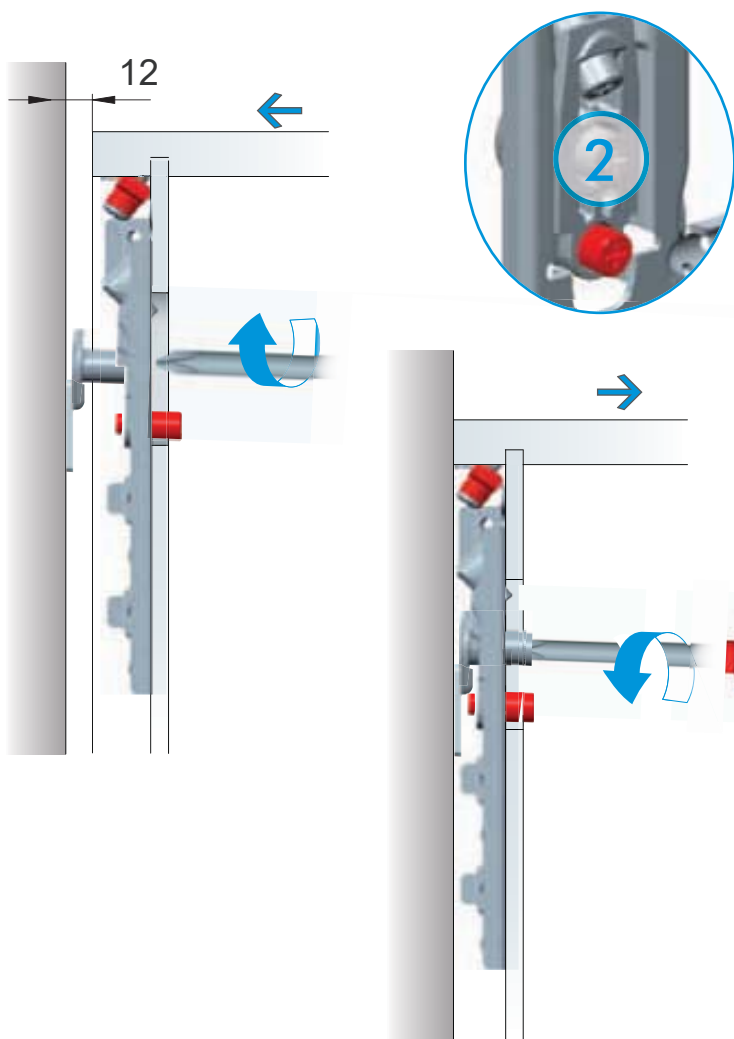
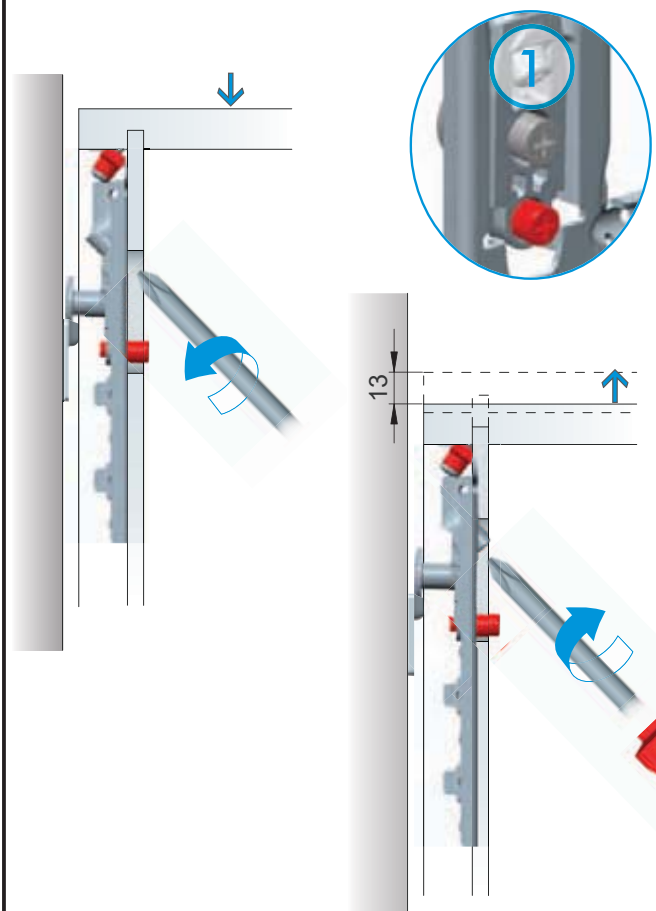
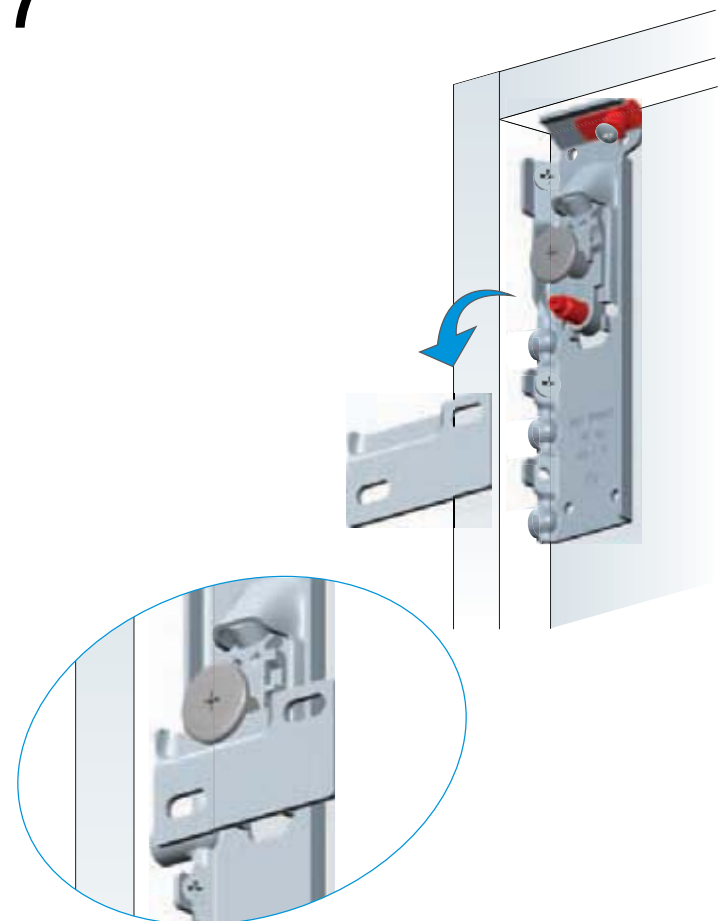

8

C0

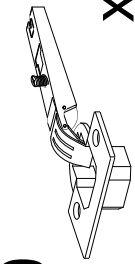

x3

P18

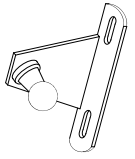

x1

P



x2

M2



3x16 mm.

x2

L15



4x15 mm.

x6

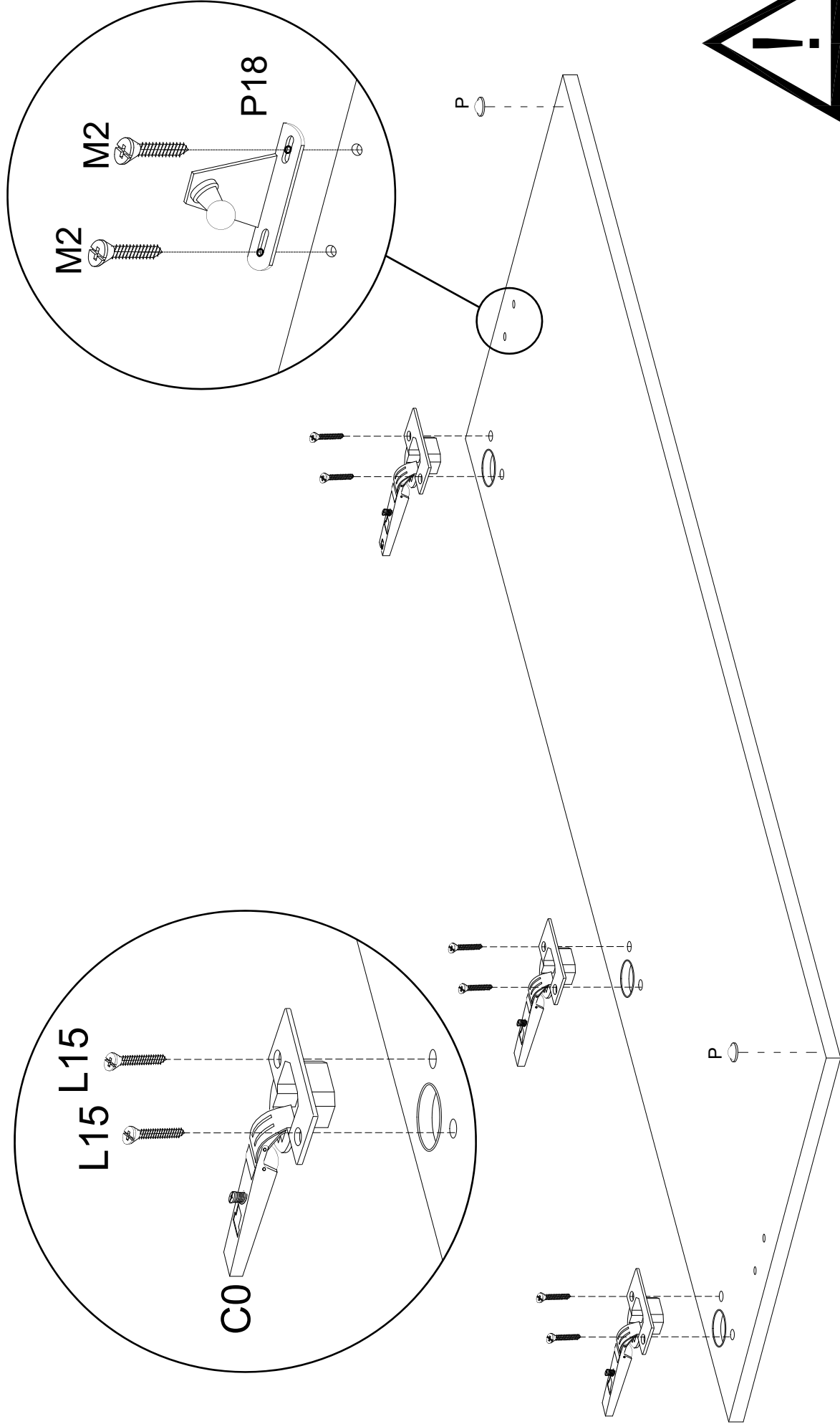

9

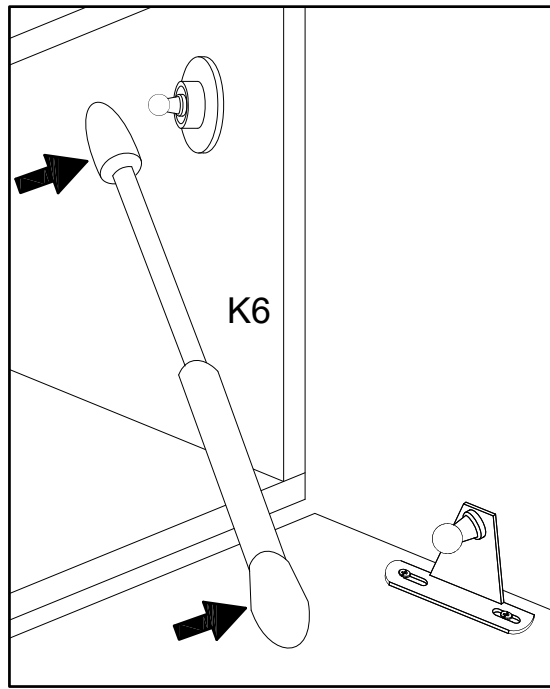
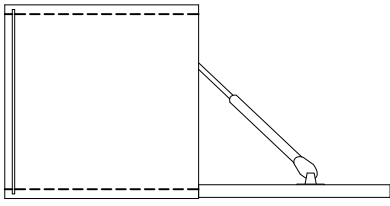

P12

ø20 mm.



x12

P19

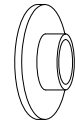

x1

K6

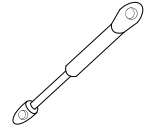

x1

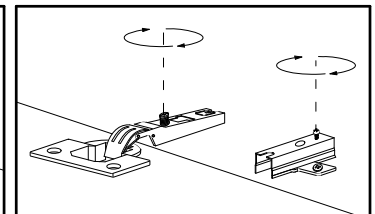
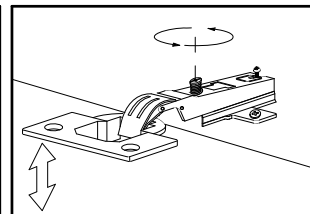
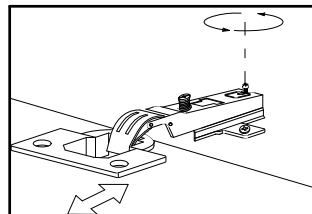
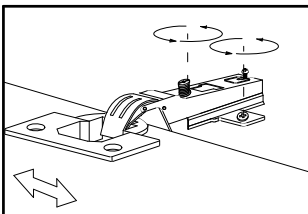
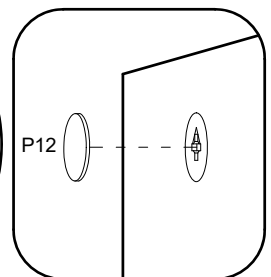
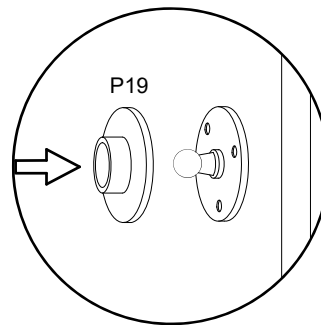
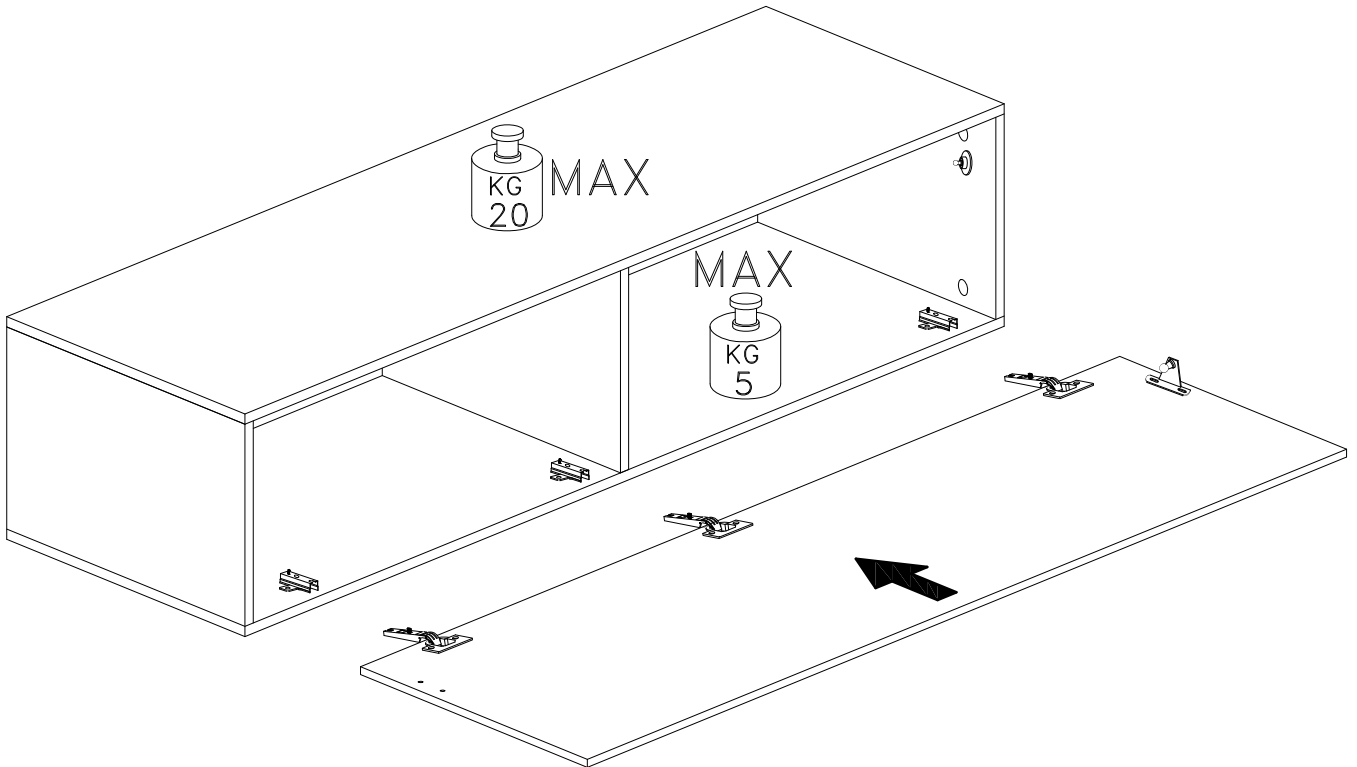



9

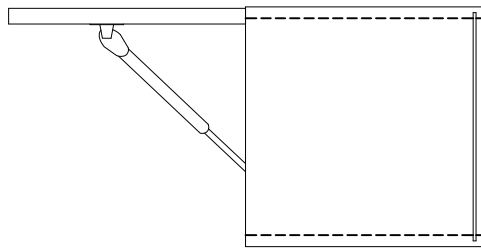

P19

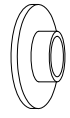

x1

K11

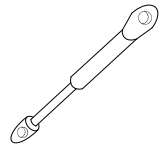

x1

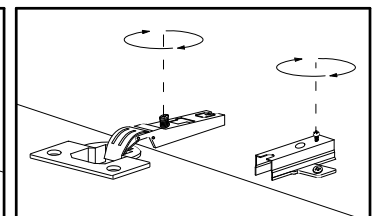
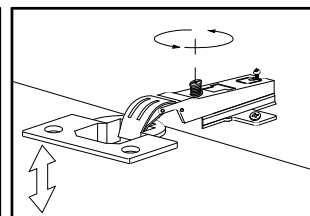
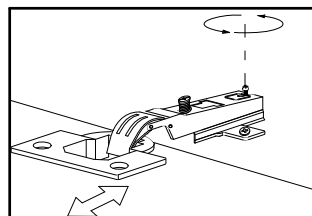
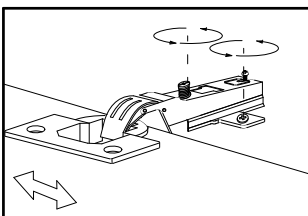
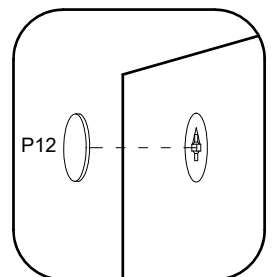
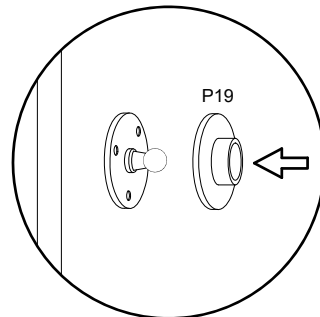
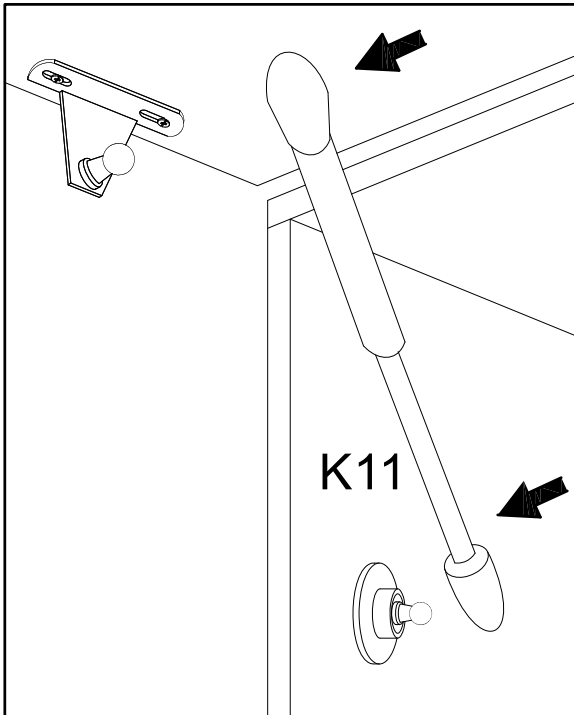
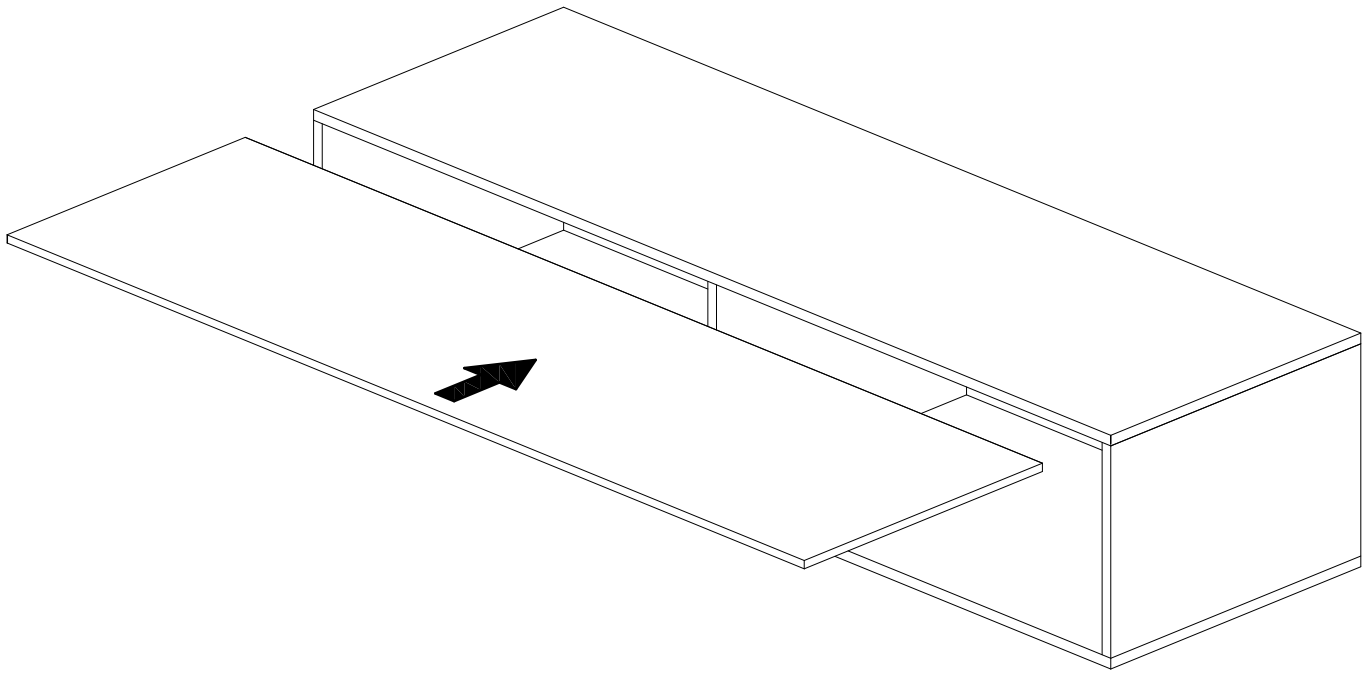

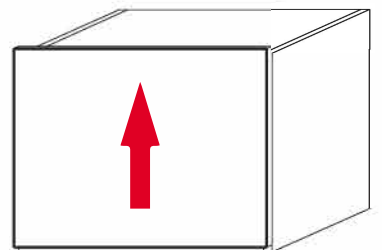
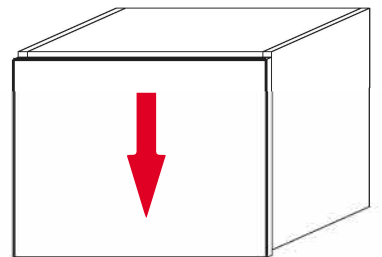
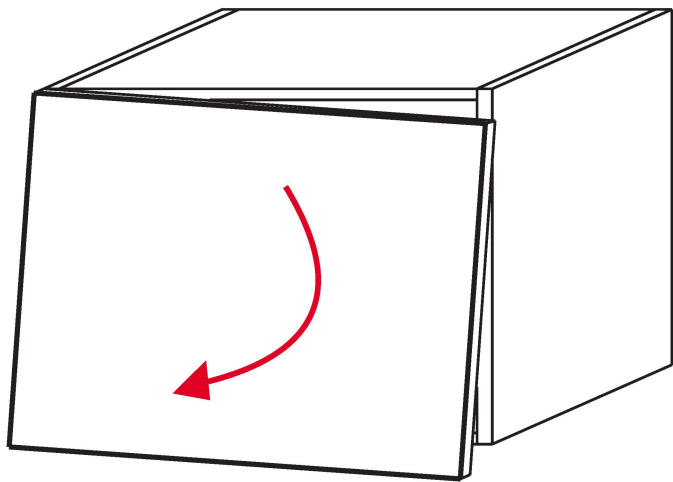
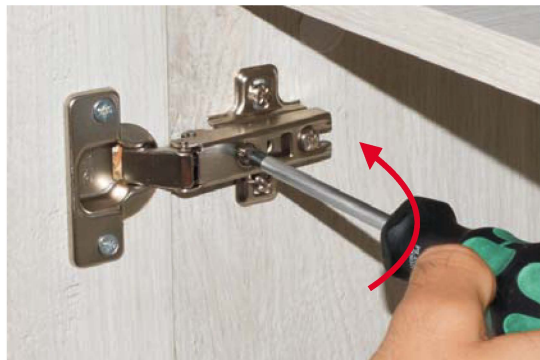
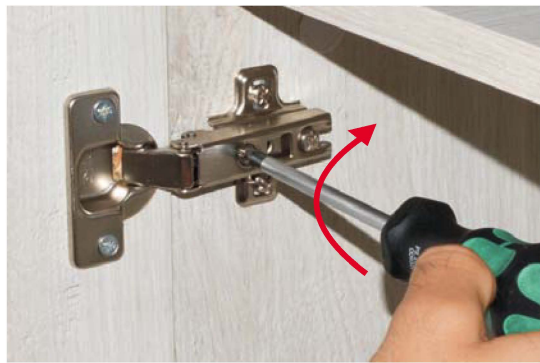
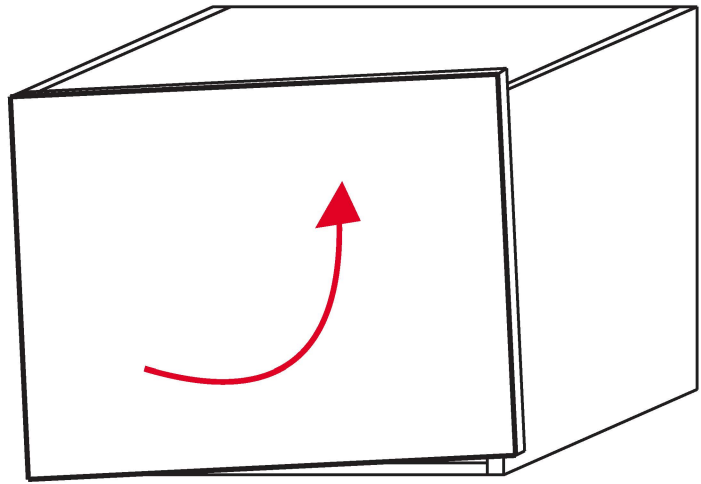
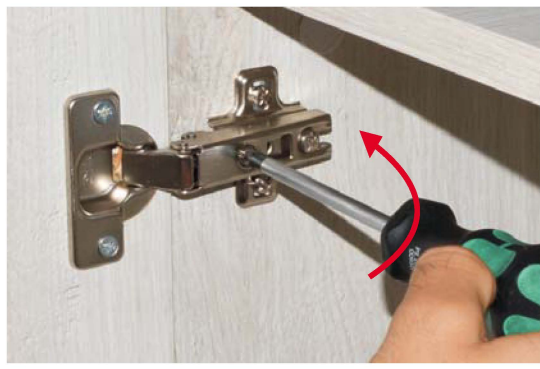

Montageanweisung / Installation instructions / Instruction de montage / Istruzioni di montaggio  
montagehandleiding / Instrukcja montazu / Montaj talimatlar / Osszeszerelési útmutatót / Nàvod k montàzi /  
Nàvod na montaz / Instructiune de montaj / Инструкция по монтажу / Montaj talimatina / Monteringsanvisningar  
Upute za montažu / Instrucciones de Montaje / Navodila za montažo

# INFINITY 2.0

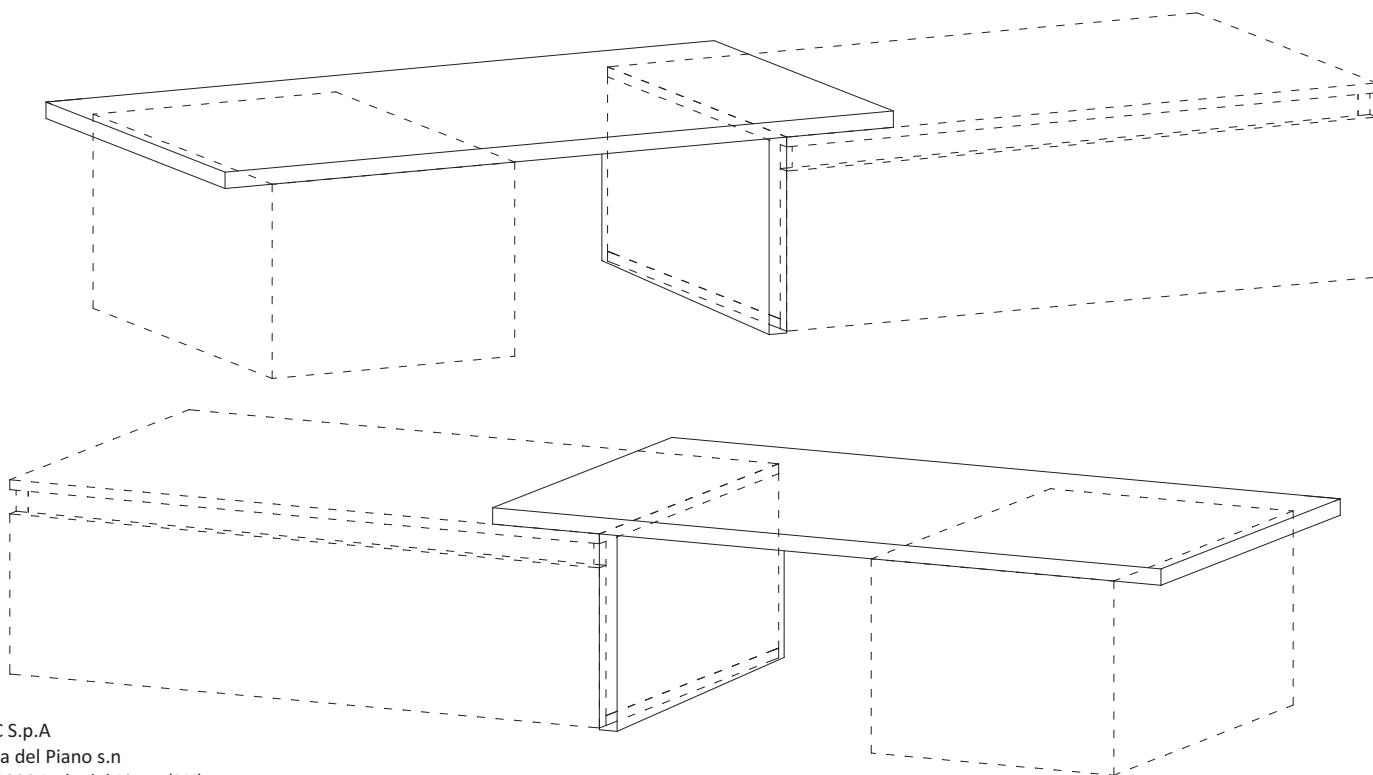
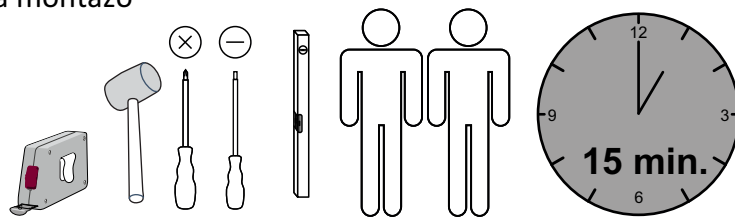

LCS.p.A  
Via del Piano s.n  
61030 Isola del Piano (PU)  
Italia  
<http://www.lcmobili.com/>

**D** – bitte lesen sie diese montageanleitung gut durch,  
Da wir für fehler, die durch falsche montage entstehen,  
Keine haftung übernehmen!

**Gb** – please read these installation instructions  
Through carefully as we cannot accept any liability  
For faults occurring as a result of incorrect installation!

**Cz** – přečtete si prosim pozorně tento návod k montáži,  
Aby jste předešli chybám vzniklých špatnou montáží,  
Za které neručíme!

**F** – veuillez lire attentivement cette notice de montage,  
Car nous déclinons toute responsabilité en cas d'erreurs  
Découlant d'un montage erroné !

**I** – prego leggere attentamente le istruzioni per il montaggio,  
Poiché decliniamo qualsiasi responsabilità  
Per difetti derivanti da montaggio errato.

**S** - läs monteringsanvisningarna noggrant.  
Vi avsåger oss allt ansvar för defekter som  
Uppstår p.g.a. Felaktig montering.

**Hr** – pažljivo pročitajte upute za montažu,  
Jer otklanjamo svaku odgovornost za pogreške  
Nastale uslijed pogrešne montaže.

**Slo** – prosimo, da pozorno preberete navodila za montažo,  
Saj zavračamo vsakršno odgovornost za napake,  
Ki bi nastale zaradi napačne montaže.

**Nl** – leest u alstublieft deze montagehandleiding goed door,  
Voor fouten door verkeerde montage zijn wij niet verantwoordelijk.

**Pl** – prosze uwaznie zapoznac sie z instrukcja montazu,  
Poniewaz nie ponosimy odpowiedzialnosci za niewlasciwy montaz.

**Hu** – Kérjük, olvassa el figyelmesen  
ezt az összeszerelési útmutatót,  
mert a helytelen összeszerelésből  
a dódó hibákért nem vállalunk felelősséget!

**SK** – Prosime, dobre prečítajte si tento návod na montáž,  
pretože nepreberáme žiadne ručenie za chyby,  
ktoré vzniknú na základe chybnej montáže!

**RO** – Vă rugăm să cititi cu atenție aceste instructiuni  
de montaj deoarece nu preluăm garanția pentru defecte  
ce apar datorită unui montaj incorect!

**RUS** – Пожалуйста, внимательно ознакомьтесь ù  
с данной инструкцией по монтажу, поскольку мы не  
несем ответственности за ошибки, причиной которых  
является неправильный монтаж.

**TU** – İlkonce kullanma klavuzunu iyi okuyun,  
yalnis montaj yapasaniz bunun sorumlusu biz degiliz.

**ES** – Se ruega leer con atención las instrucciones  
de montaje deibido a que declinamos cualquier  
responsabilidad  
por defectos derivados de un montaje erróneo.

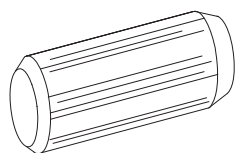
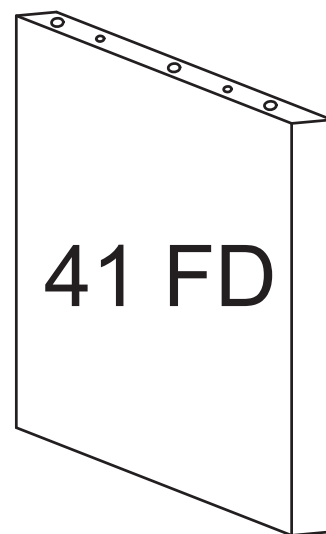
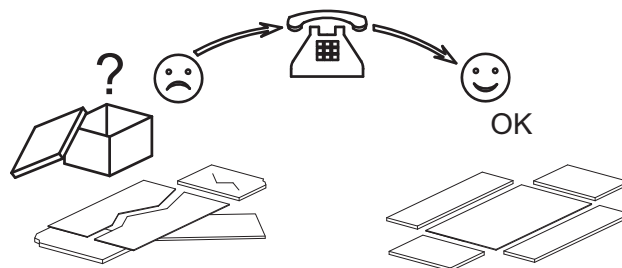
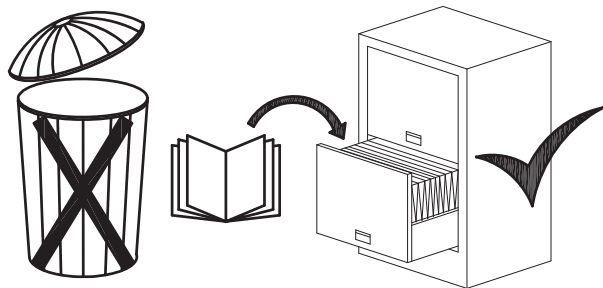

12x50 mm.

**B x3**

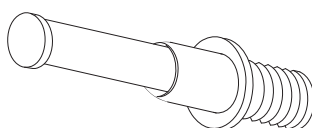

**D x2**



4x18 mm.

**L418 x4**

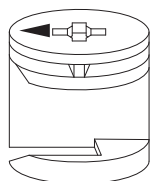

∅15 x 30 mm.

**C x2**

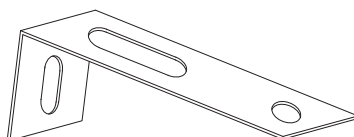

**PST x2**

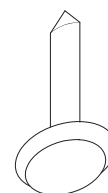

**CH x2**

1

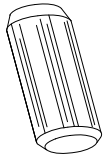

12x50 mm.

B x3 D x2 CH x2

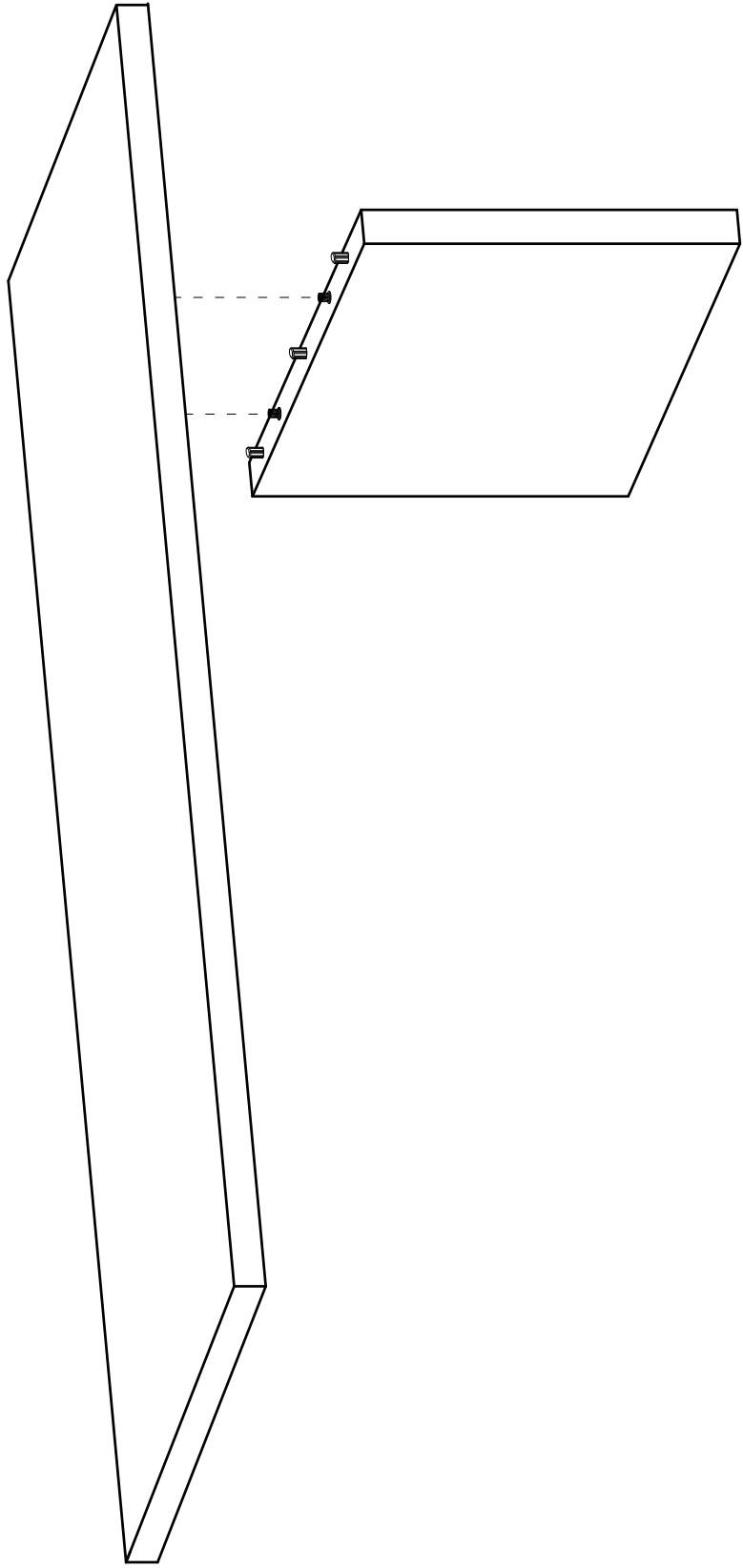
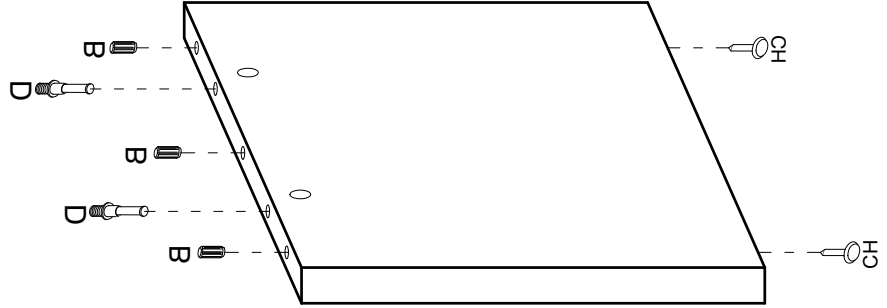
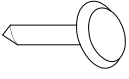
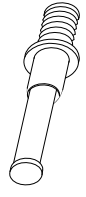

2

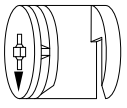

∅15 x 30 mm.

C x2

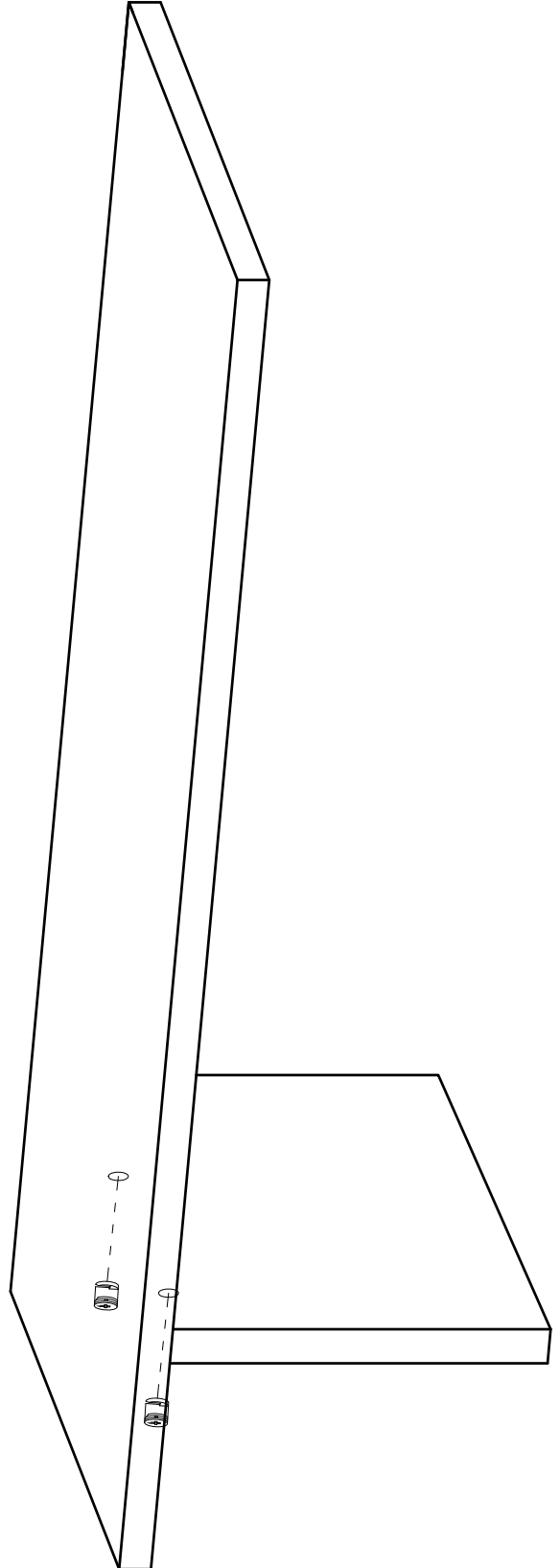
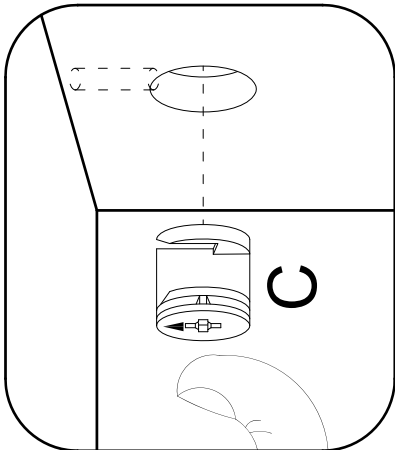
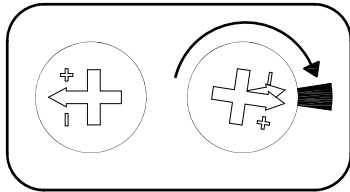
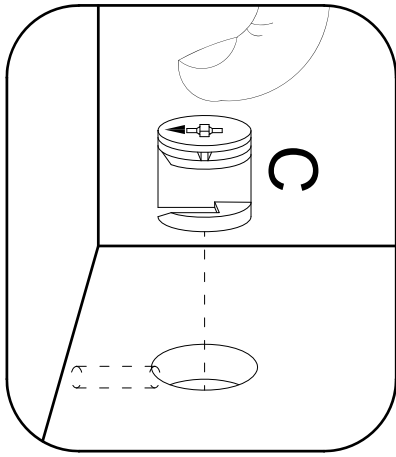
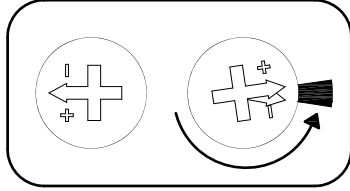
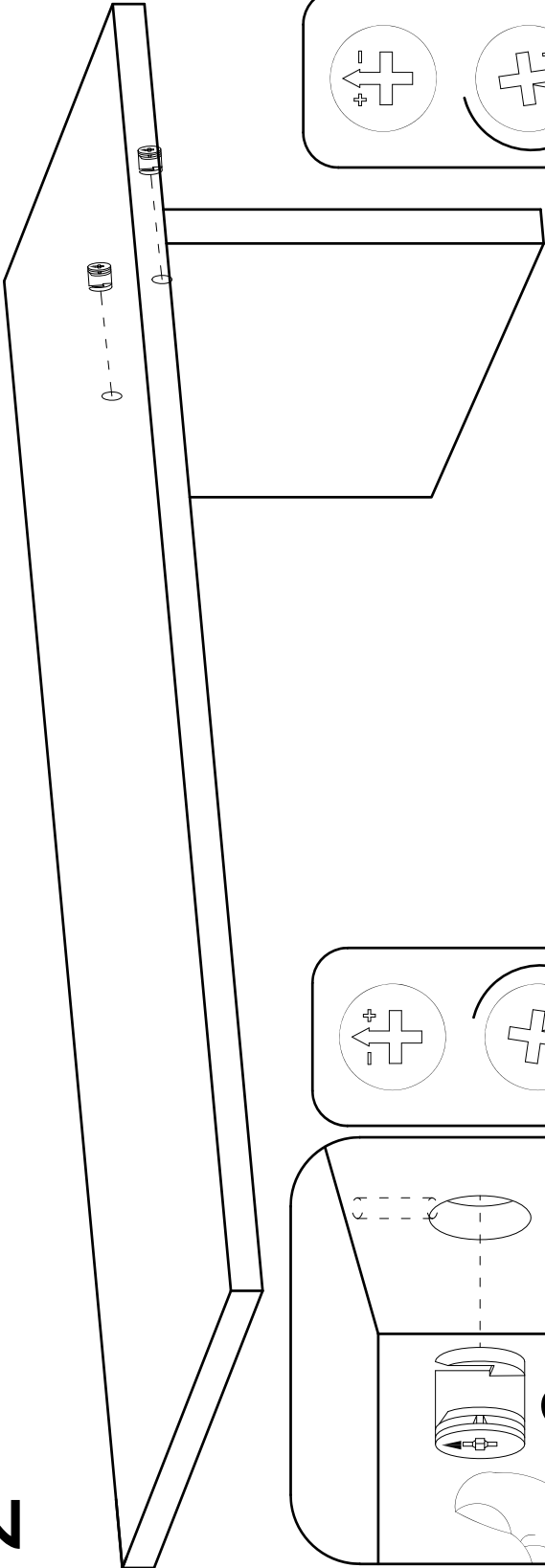

Gentile Cliente

Il montaggio dei pensili deve essere effettuato da personale competente. I tasselli di fissaggio non sono compresi nella ferramenta. Scegliere il tipo di tassello per il fissaggio più adatto alla tipologia di muro. Assicurarsi l'idoneità della parete per un sostegno sicuro del pensile.

Dear Customer,

The assembling of the hanging elements must be done by a competent staff. The wall plugs are not included in the hardware package. Choose the wall plugs more suitable to the type of the wall. Ensure the suitability of the wall for a secure support of the hanging element.

Sehr geehrter Kunde, die Montage der Hängeelemente muss von Fachpersonal ausgeführt werden!

Bitte verwenden Sie eigene Dübel, die der Beschaffenheit der Wand entsprechen. Zu Ihrer eigenen Sicherheit legen wir dem Beschlagbeutel keine Dübel bei.

Cher client, les éléments muraux ne peuvent être installés que par du personnel qualifié !

Veillez utiliser vos propres ancrages adaptés à la nature du mur.

Pour votre sécurité, nous n'incluons pas de chevilles dans le matériel.

Estimado cliente, el montaje de los muebles colgados en la pared debe ser realizado por personal competente. Los tacos de fijación no están incluidos en la bolsa de herrajes. Elija el tipo de anclaje de fijación que mejor se adapte al tipo de pared. Asegúrese de que la pared sea adecuada para un soporte seguro del mueble colgado en la pared.

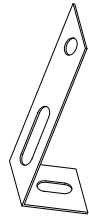

## PST x2 L418 x4

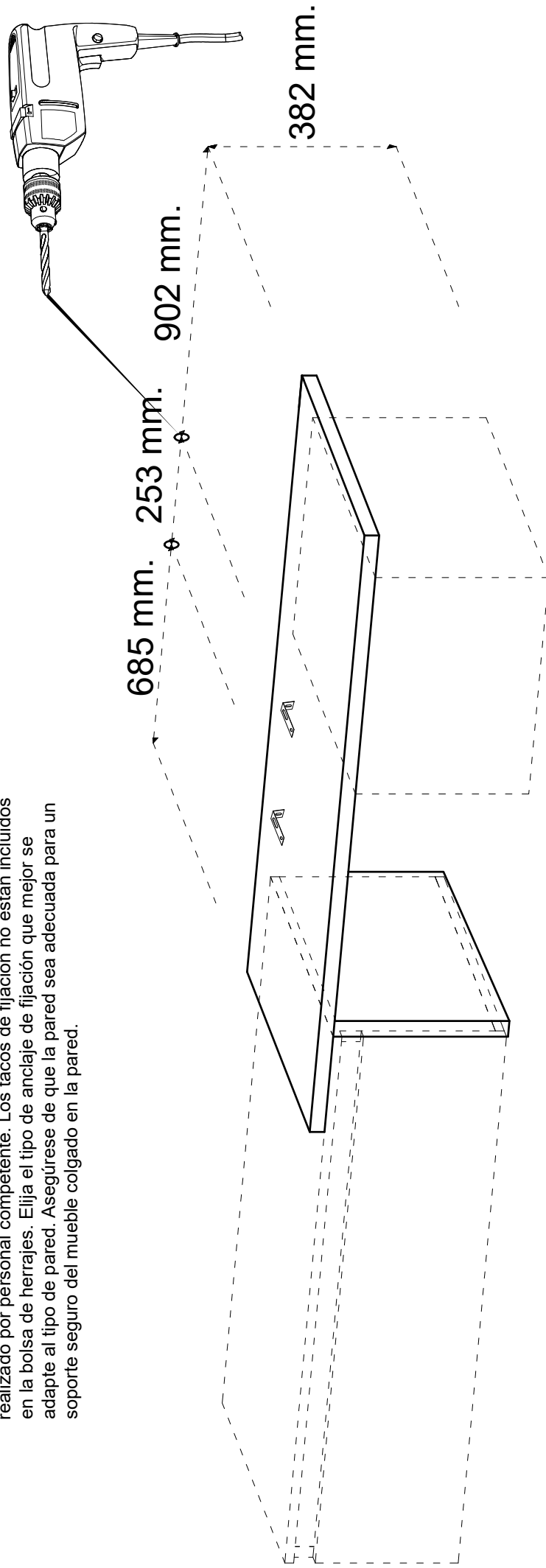
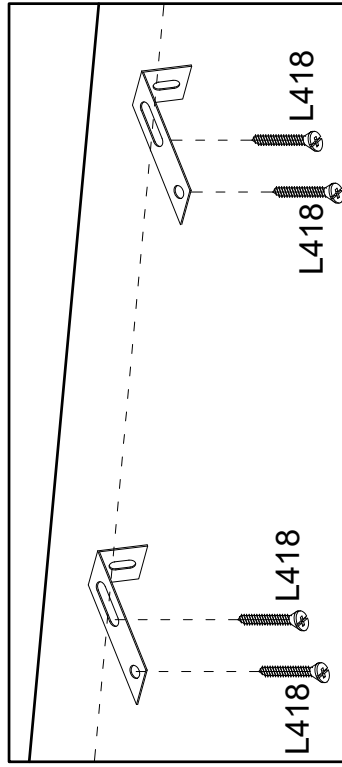

FANTASY  
COMP. 3

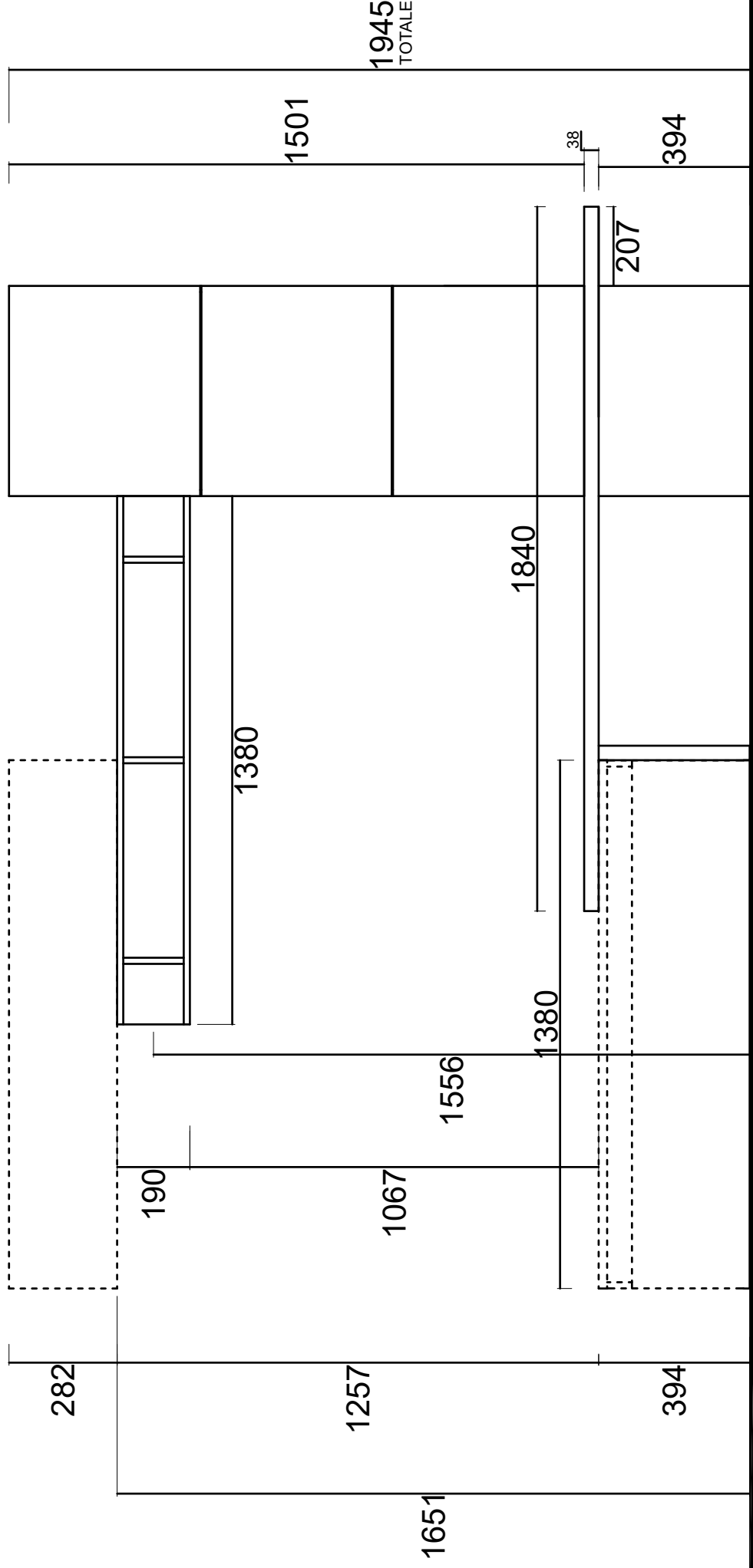
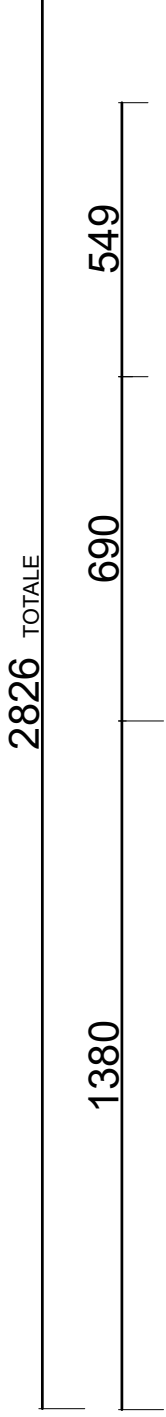



# -01

Montageanweisung / Installation instructions / Instruction de montage / Istruzioni di montaggio  
montagehandleiding / Instrukcja montazu / Montaj talimatlar / Osszeszerelési útmutató / Nàvod k montázi /  
Nàvod na montaz / Instructiune de montaj / Инструкция по монтажу / Montaj talimatina / Monteringsanvisningar  
Upute za montažu / Instrucciones de Montaje / Navodila za montažo

## INFINITY 2.0

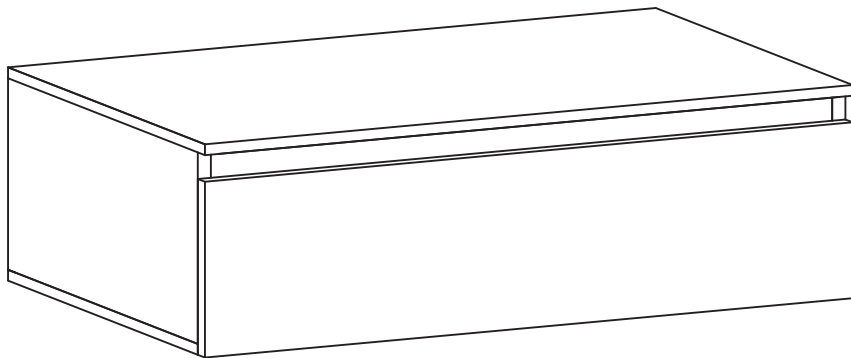
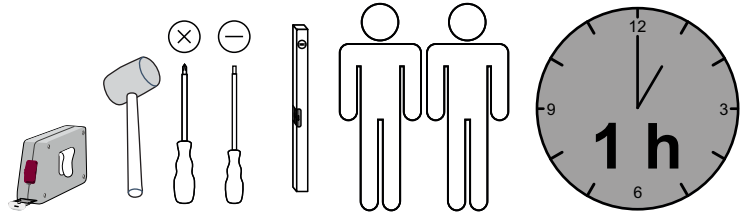

**D** – bitte lesen sie diese montageanleitung gut durch,  
Da wir für fehler, die durch falsche montage entstehen,  
Keine haftung übernehmen!

**Gb** – please read these installation instructions  
Through carefully as we cannot accept any liability  
For faults occurring as a result of incorrect installation!

**Cz** – přečtěte si prosím pozorně tento návod k montáži,  
Aby jste předešli chybám vzniklých špatnou montáží,  
Za které neručíme!

**F** – veuillez lire attentivement cette notice de montage,  
Car nous déclinons toute responsabilité en cas d'erreurs  
Découlant d'un montage erroné !

**I** – prego leggere attentamente le istruzioni per il montaggio,  
Poiché decliniamo qualsiasi responsabilità  
Per difetti derivanti da montaggio errato.

**S** - läs monteringsanvisningarna noggrant.  
Vi avsåger oss allt ansvar för defekter som  
Uppstår p.g.a. Felaktig montering.

**Hr** – pažljivo pročitajte upute za montažu,  
Jer otklanjamo svaku odgovornost za pogreške  
Nastale uslijed pogrešne montaže.

**Slo** – prosimo, da pozorno preberete navodila za montažo,  
Saj zavračamo vsakršno odgovornost za napake,  
Ki bi nastale zaradi napačne montaže.

**Nl** – leest u alstublieft deze montagehandleiding goed door,  
Voor fouten door verkeerde montage zijn wij niet verantwoordelijk.

**Pl** – prosze uwaznie zapoznac sie z instrukcja montazu,  
Poniewaz nie ponosimy odpowiedzialnosci za niewlasciwy montaz.

**HU** – Kérjük, olvassa el figyelmesen  
ezt az összeszerelési útmutatót,  
mert a helytelen összeszerelésből  
a dódó hibákért nem vállalunk felelősséget!

**SK** – Prosíme, dobre prečítajte si tento návod na montáž,  
pretože nepreberáme žiadne ručenie za chyby,  
ktoré vzniknú na základe chybnej montáže!

**RO** – Vă rugăm să cititi cu atenție aceste instructiuni  
de montaj deoarece nu preluăm garanția pentru defecte  
ce apar datorită unui montaj incorect!







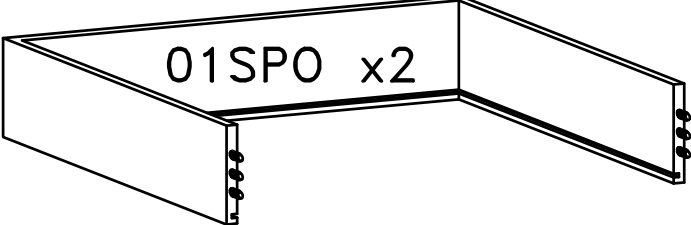
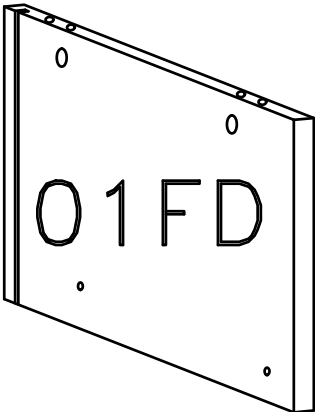
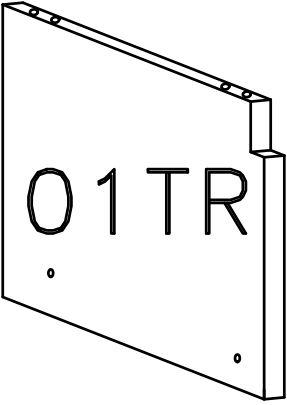
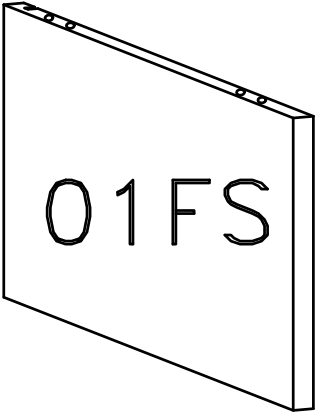
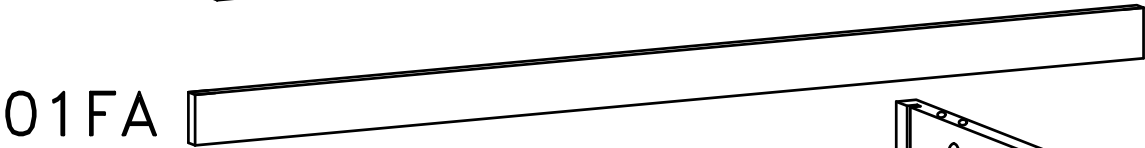
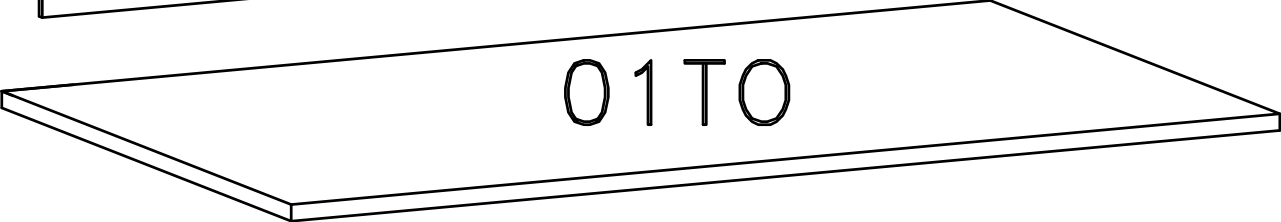

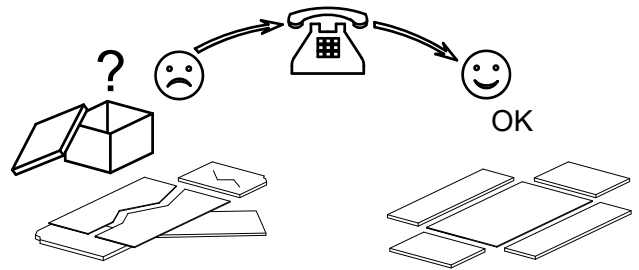
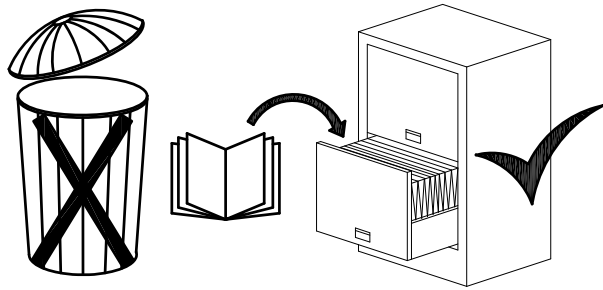
**RUS** – Пожалуйста, внимательно ознакомьтесь ù  
с данной инструкцией по монтажу, поскольку мы не  
несем ответственности за ошибки, причиной которых  
является неправильный монтаж.

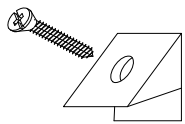
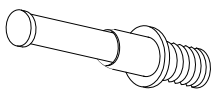
**TU** – İlkonce kullanma klavuzunu iyi okuyun,  
yalnis montaj yapasaniz bunun sorumlusu biz degiliz.

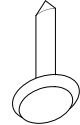
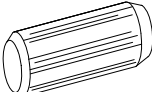
**ES** – Se ruega leer con atención las instrucciones  
de montaje debido a que declinamos cualquier  
responsabilidad  
por defectos derivados de un montaje erróneo.

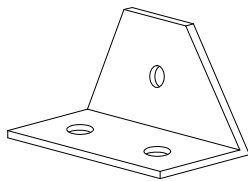
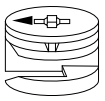

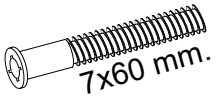
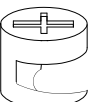
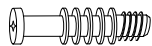

 <b>F x12</b>	 <b>D x6</b>	 <b>P x4</b>	 <b>CH x6</b>
 8x30 mm. <b>B x12</b>	 <b>F3 x6</b>	 <b>P7 x3</b>	
 ø15 x 12 mm <b>C x6</b>	 4x18 mm. <b>L418 x9</b>	 6x9mm. <b>E9 x8</b>	 7x60 mm. <b>E x6</b>
 ø12 mm. <b>C1 x8</b>	 <b>D1 x8</b>	 3.5x16 mm. <b>L3516 x8</b>	

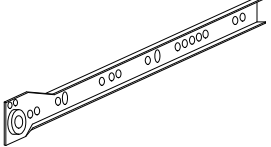
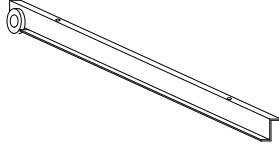
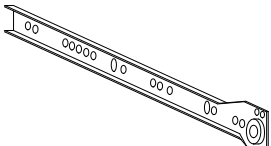
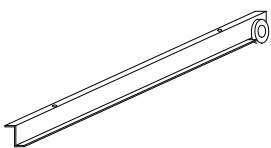
<b>CL</b> 	<b>DR</b> 
<b>CR</b> 	<b>DL</b> 
<b>x2</b>	<b>x2</b>
<b>x2</b>	<b>x2</b>

N3AST

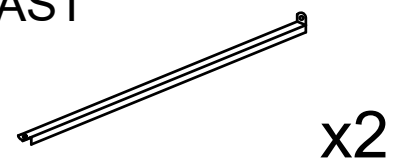

1



8x30 mm.

B x12



D x6

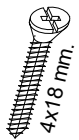

4x18 mm.

L418 x6

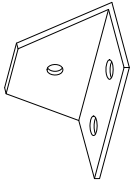

P7 x3

CL

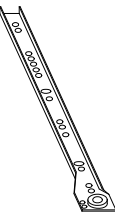

CR

E9

x2

E9

x8



6x9mm.

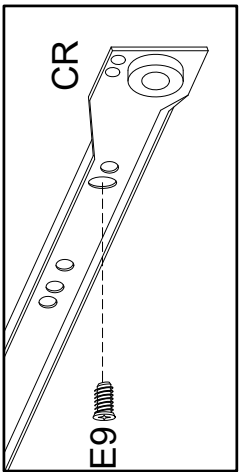
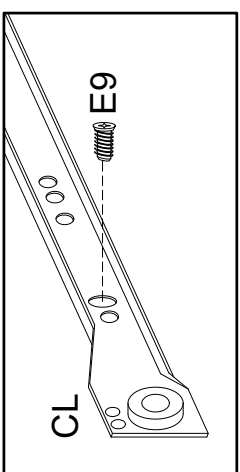
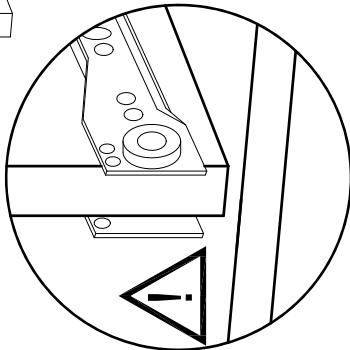
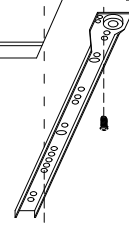
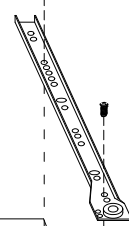
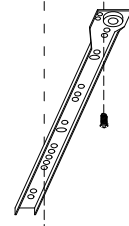
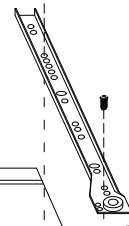
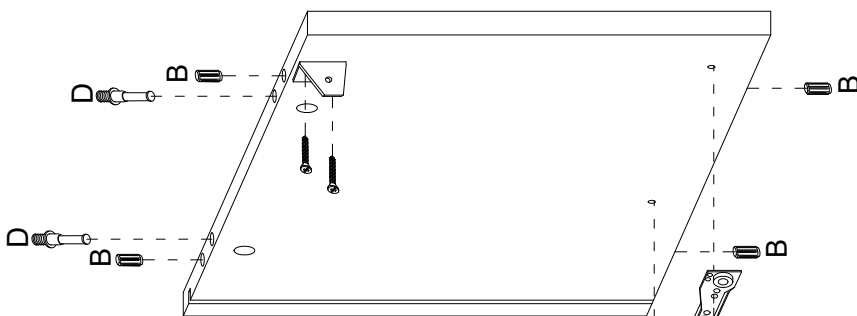
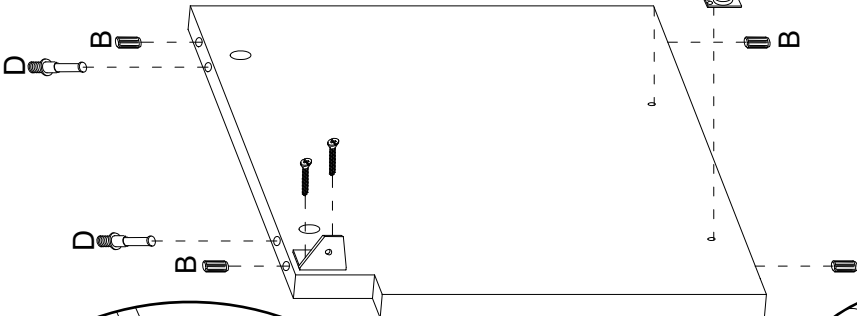
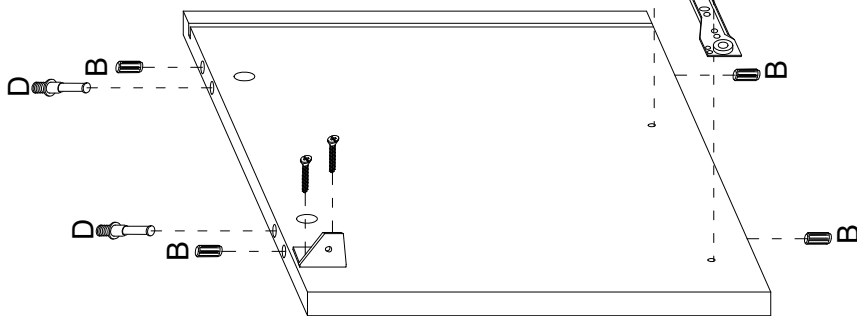
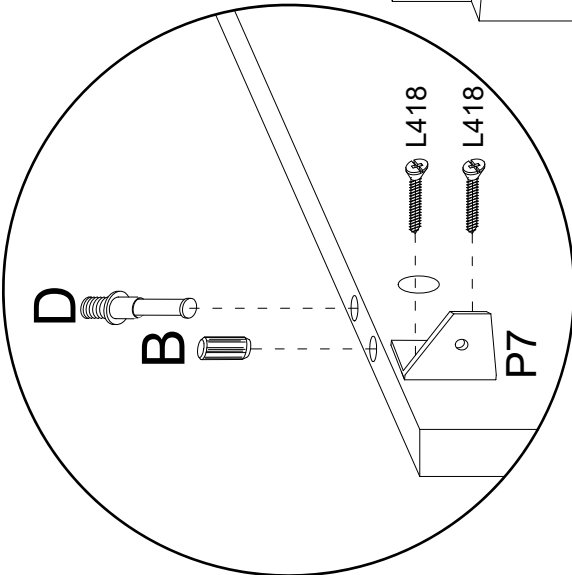

# 2

CH

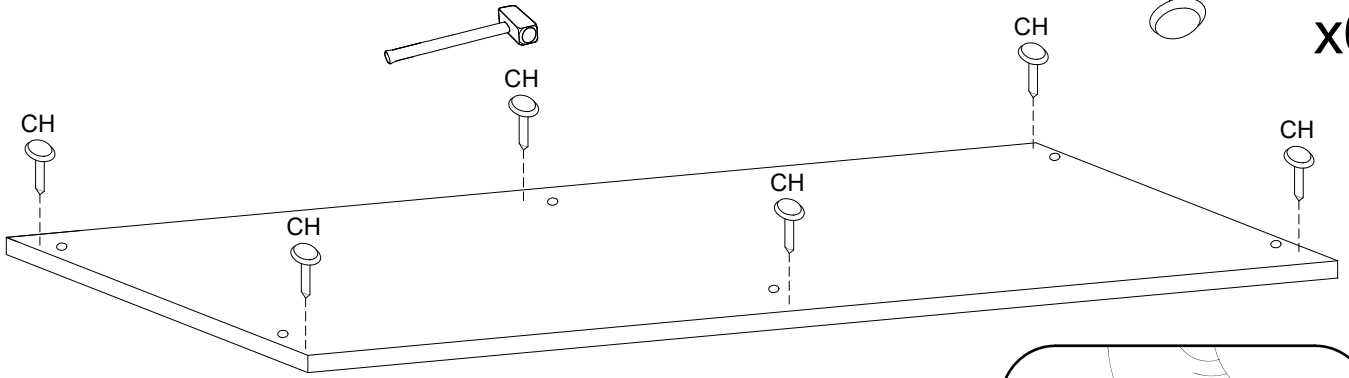

x6

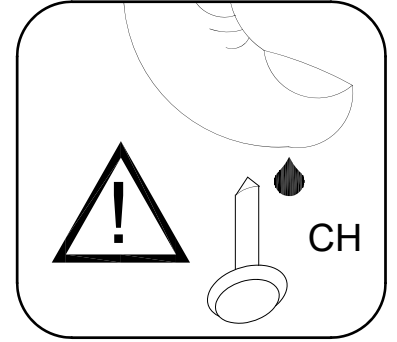

# E

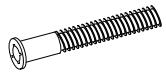

7x60 mm.

x6

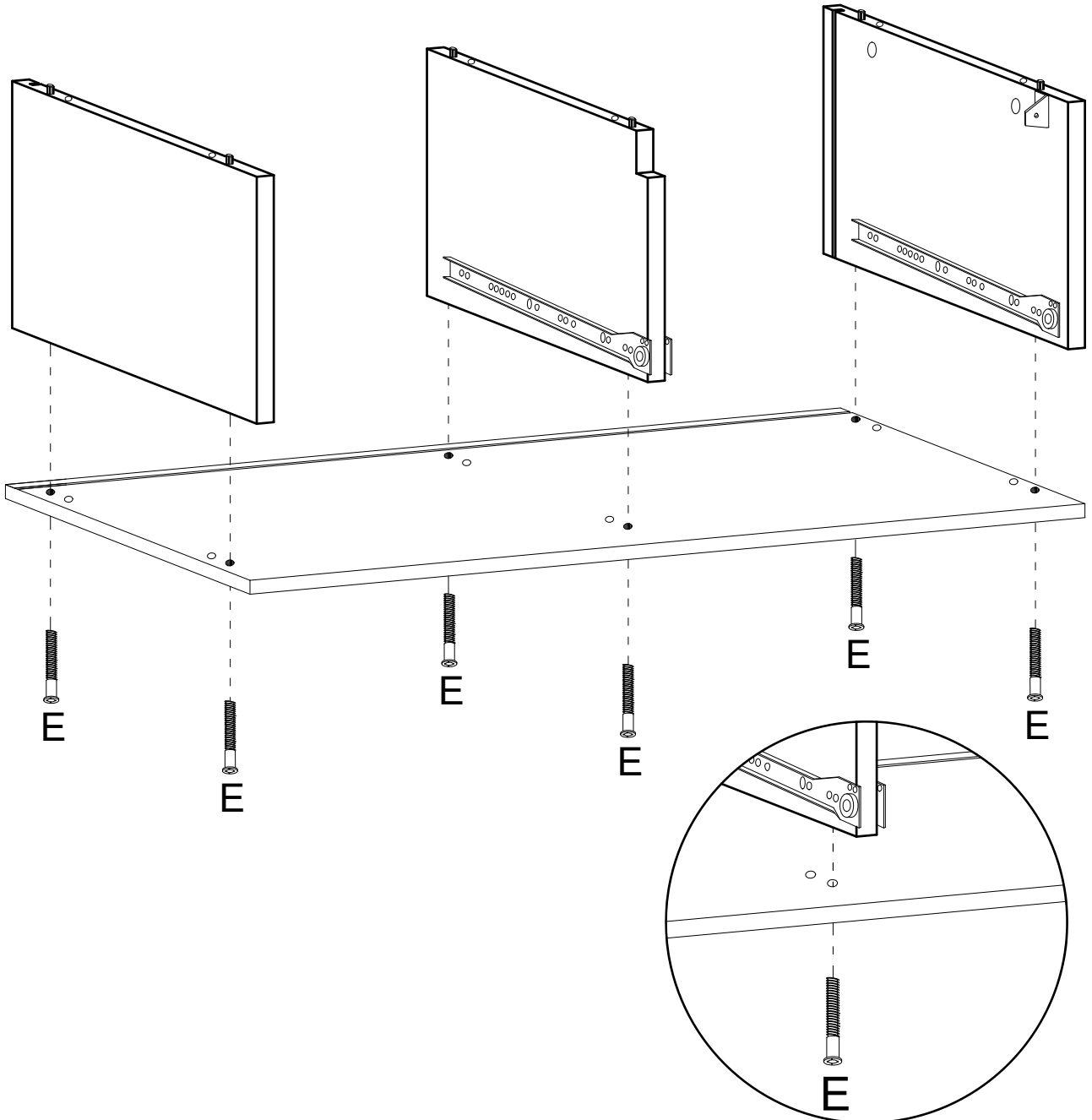

3

L418

4x18 mm. x3

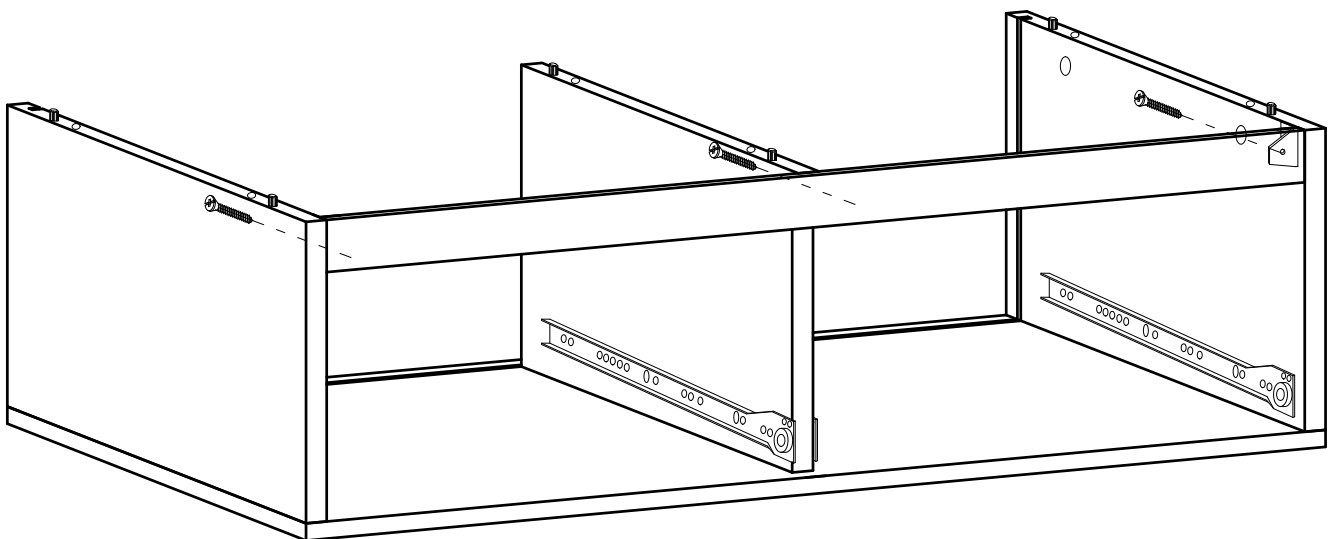
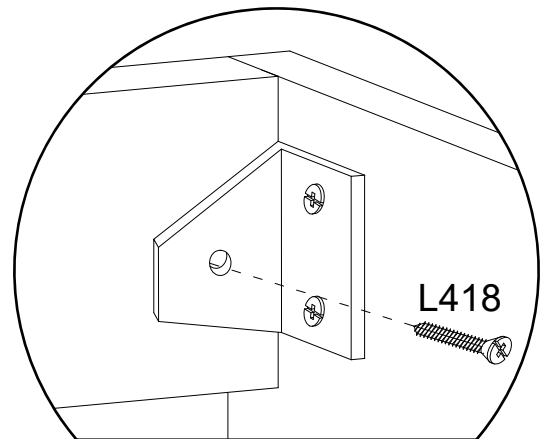
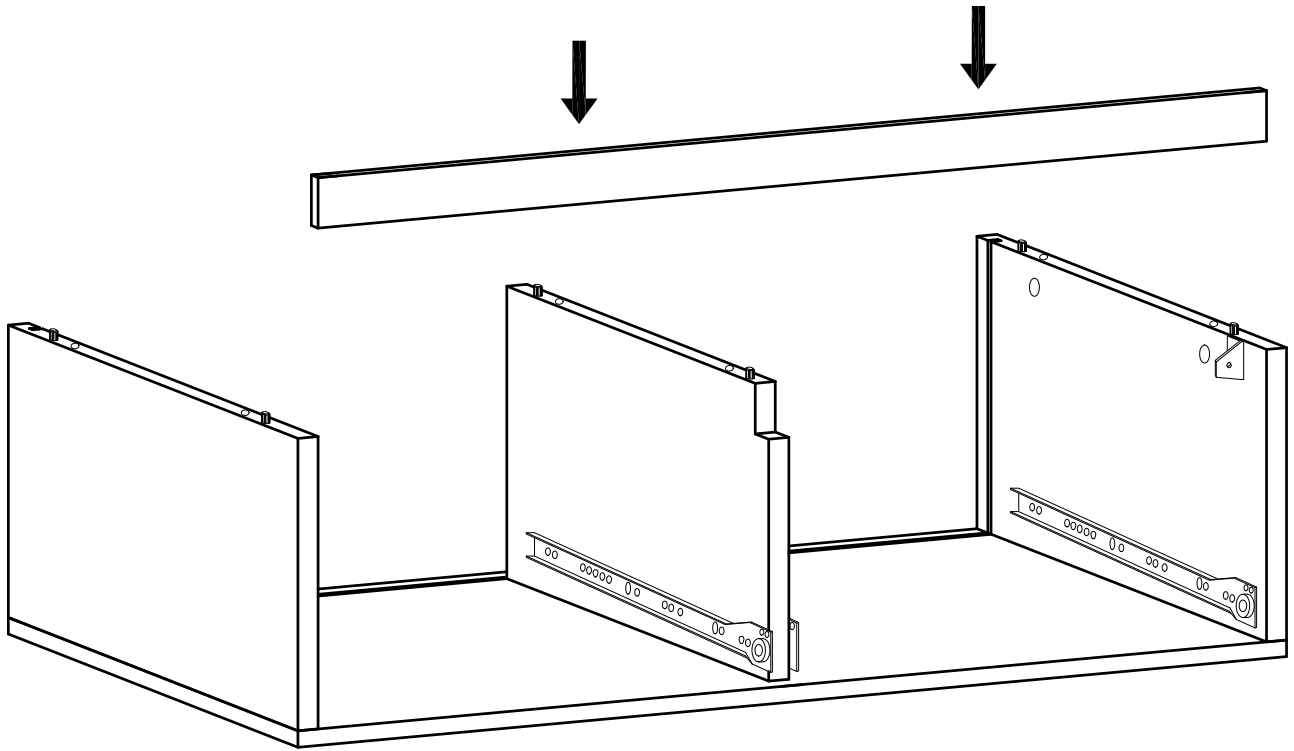

4

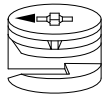

∅15 x 12 mm

C x6

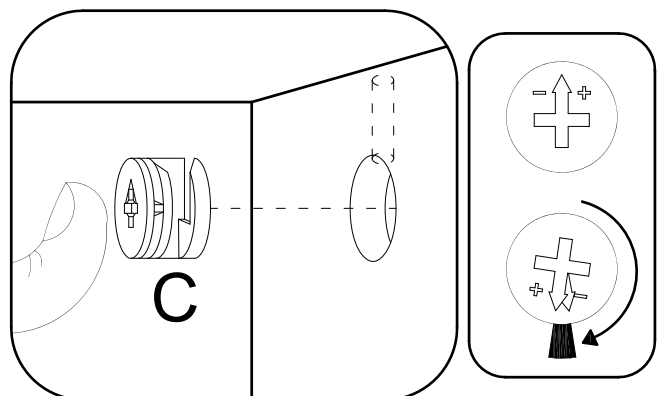
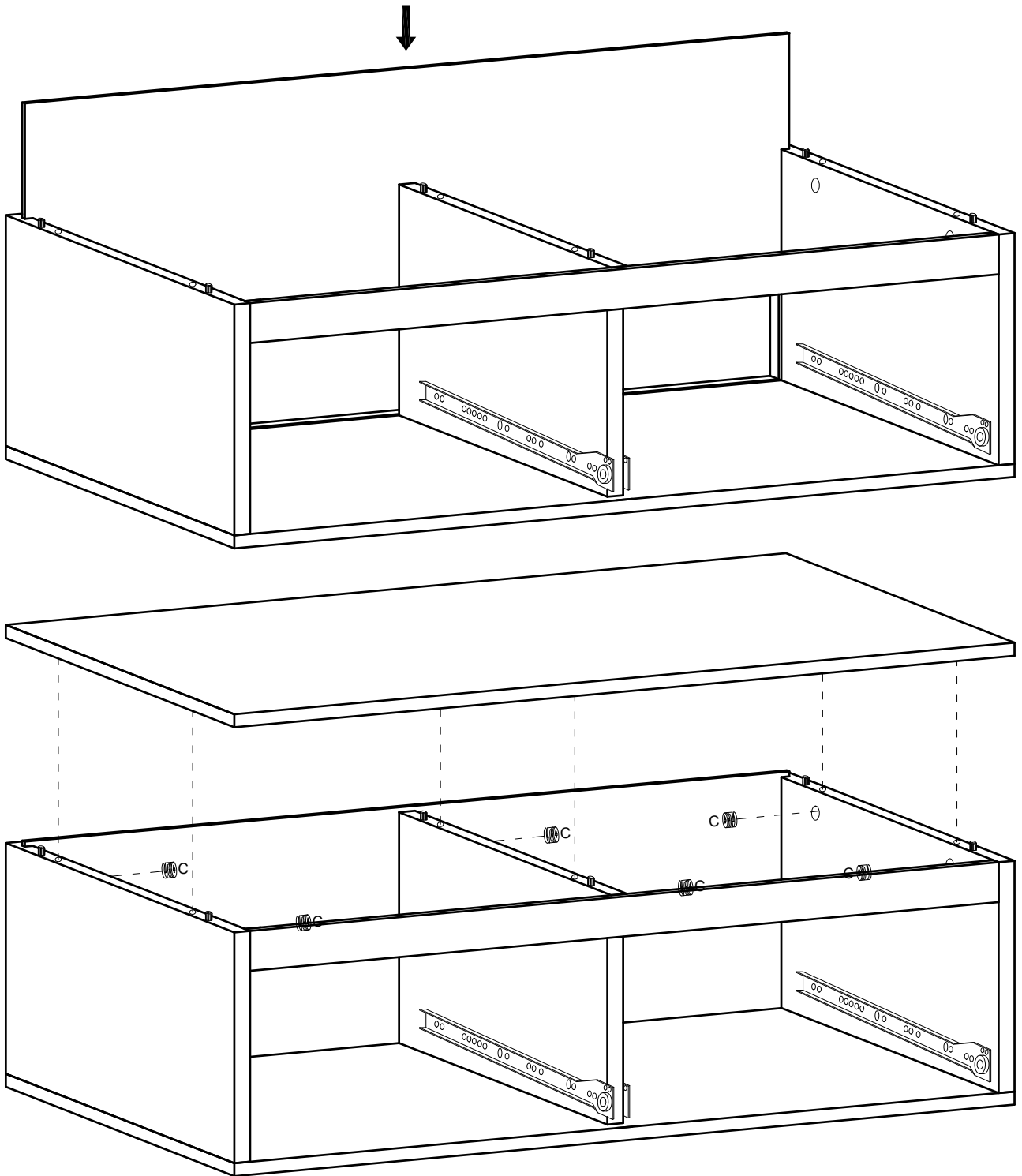

5

F

x8

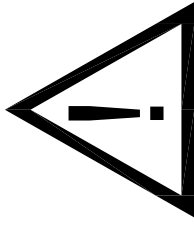
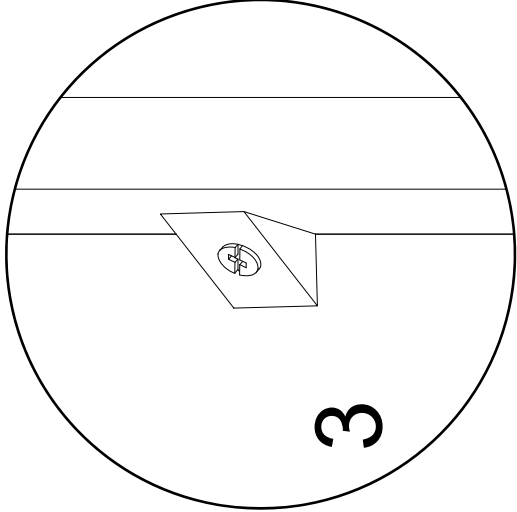
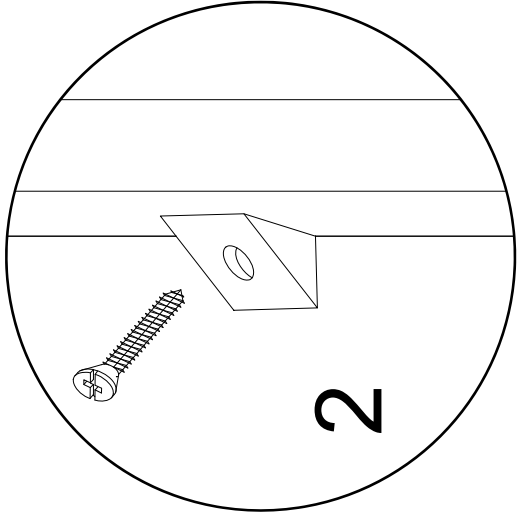
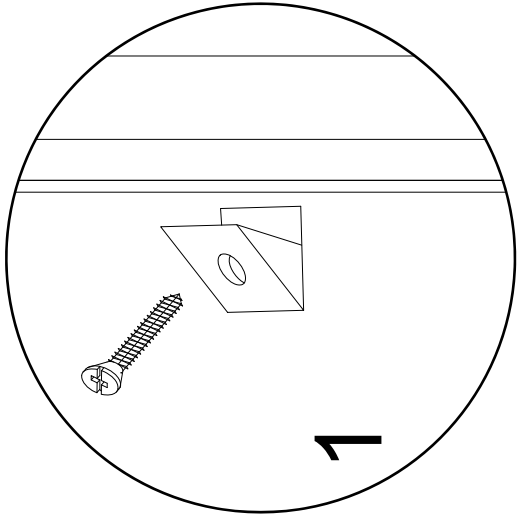
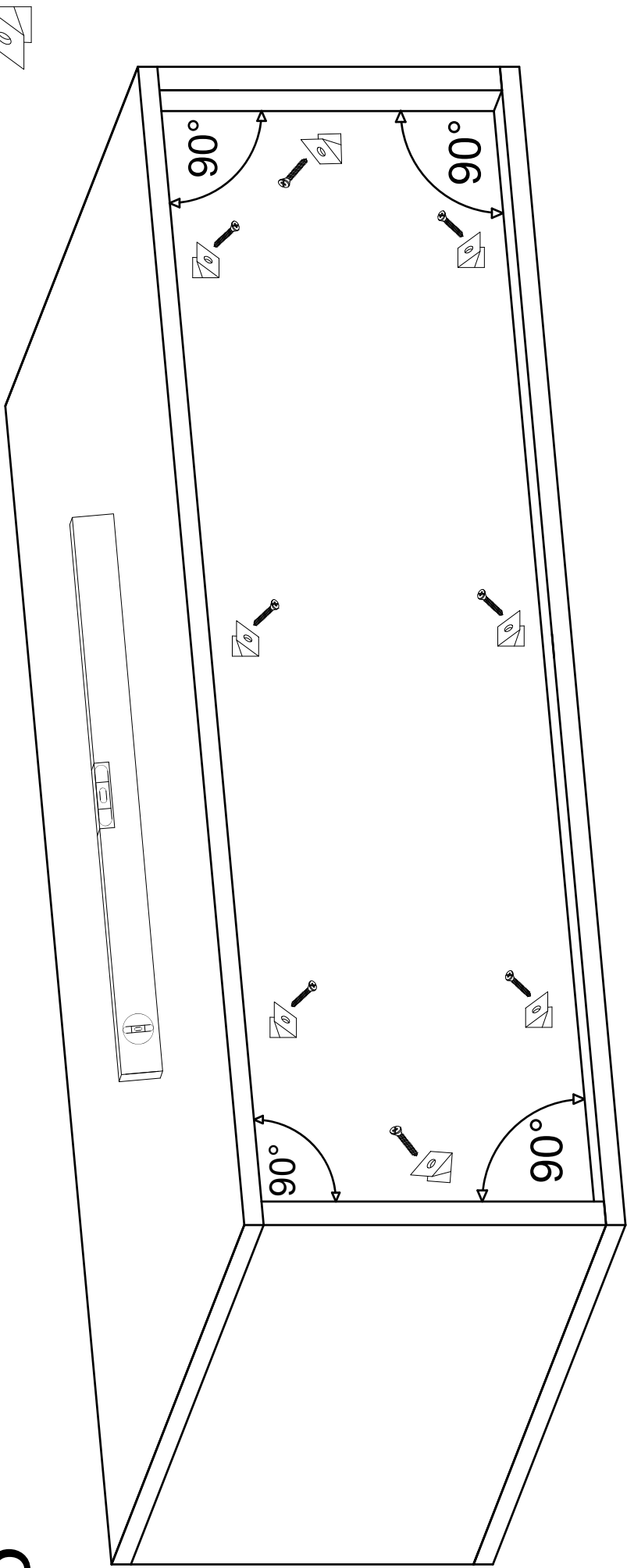



6

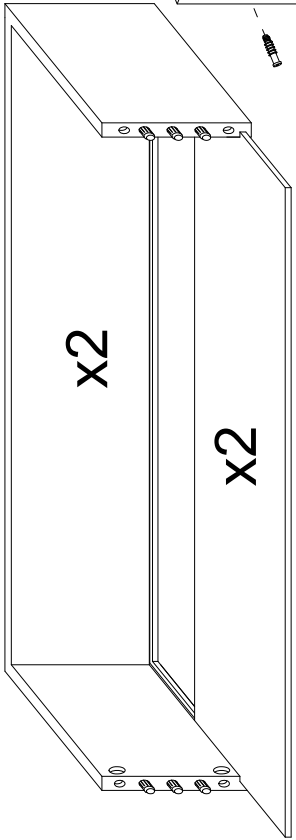

C1

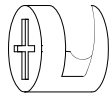

ø12 mm.

x8

D1

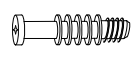

x8

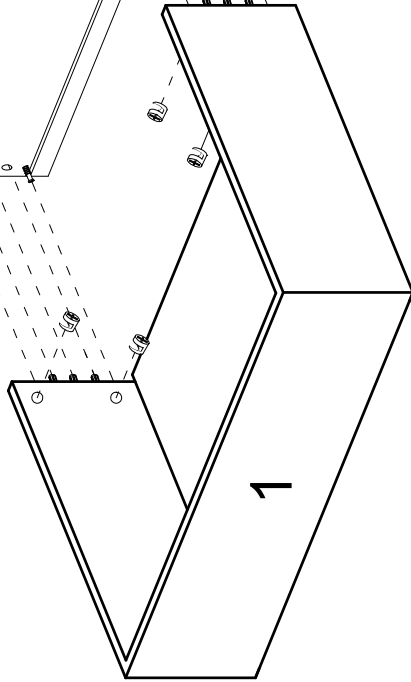
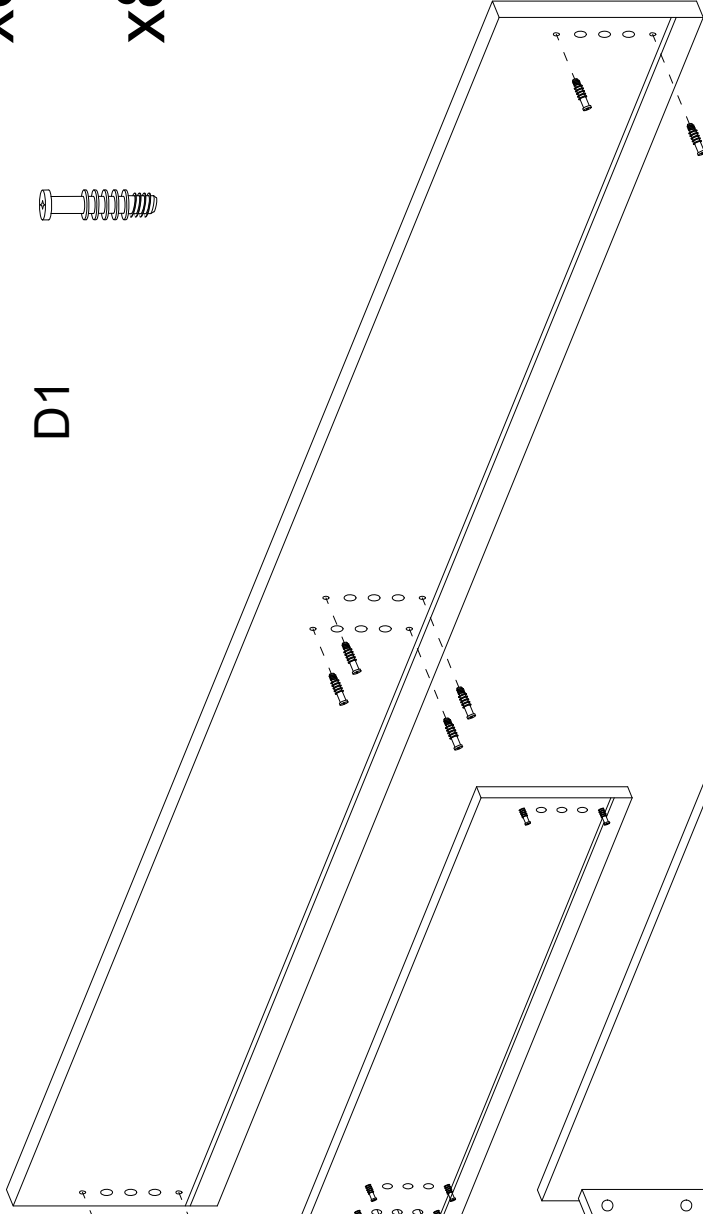

1

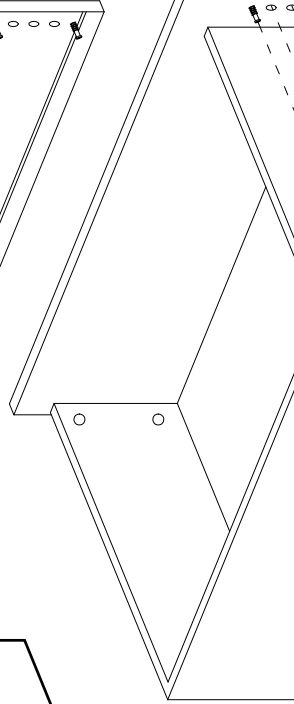

2

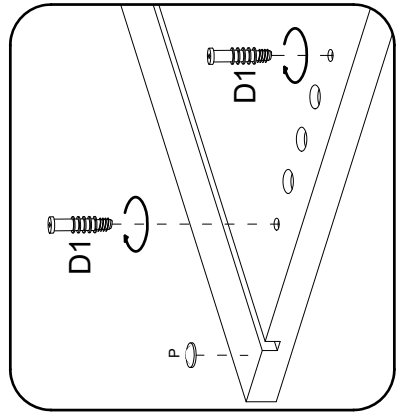
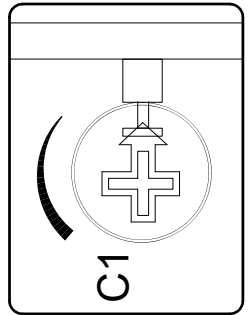
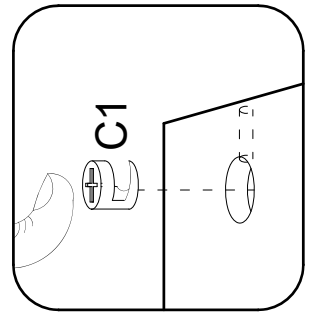
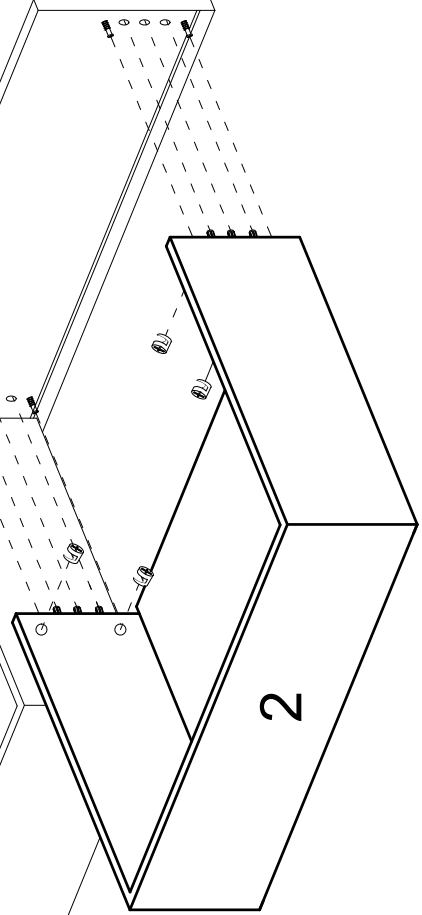



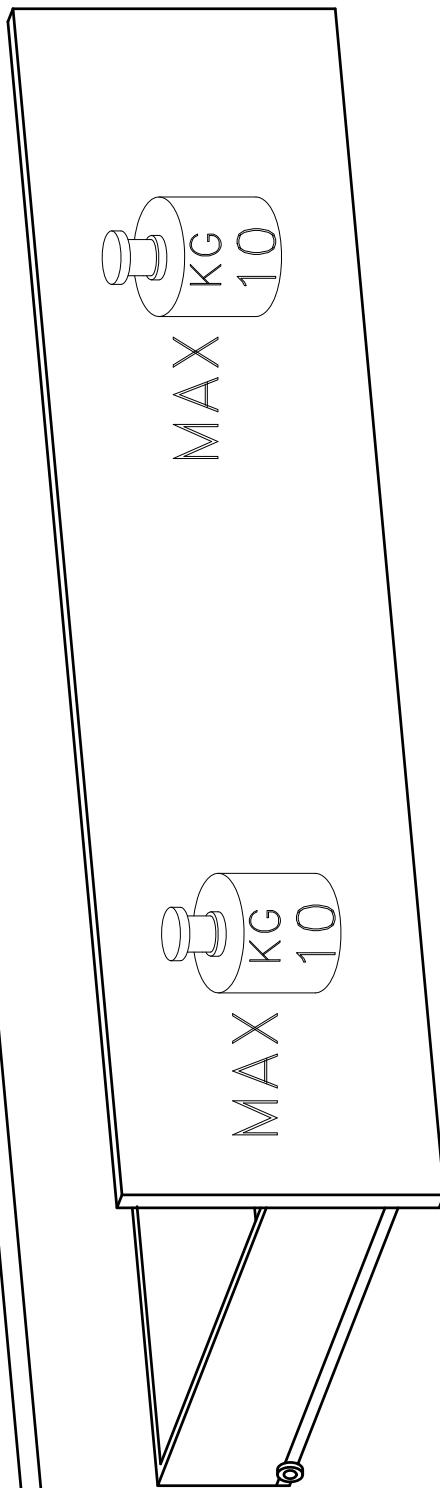
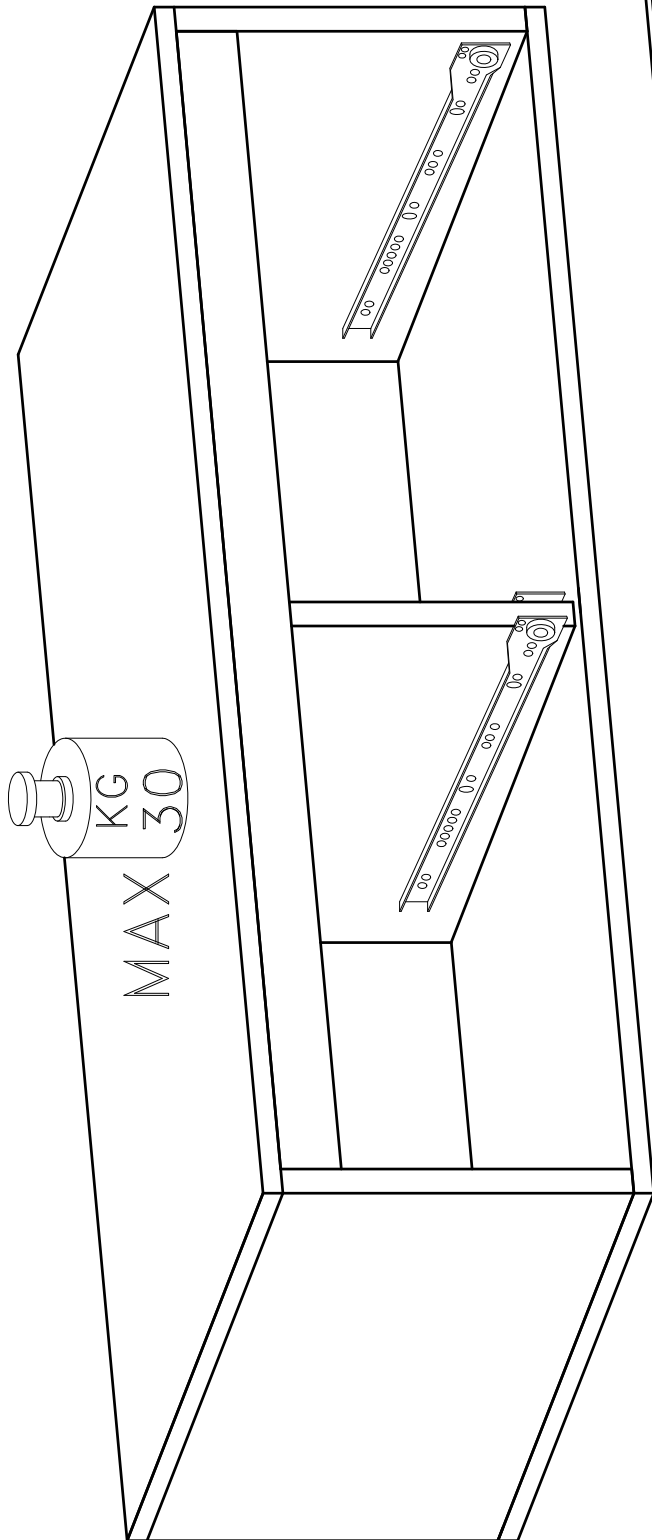

# -03

Montageanweisung / Installation instructions / Instruction de montage / Istruzioni di montaggio  
montagehandleiding / Instrukcja montazu / Montaj talimatlar / Osszeszerelési útmutató / Nàvod k montázi /  
Nàvod na montaz / Instructiune de montaj / Инструкция по монтажу / Montaj talimatina / Monteringsanvisningar  
Upute za montažu / Instrucciones de Montaje / Navodila za montažo

## INFINITY 2.0

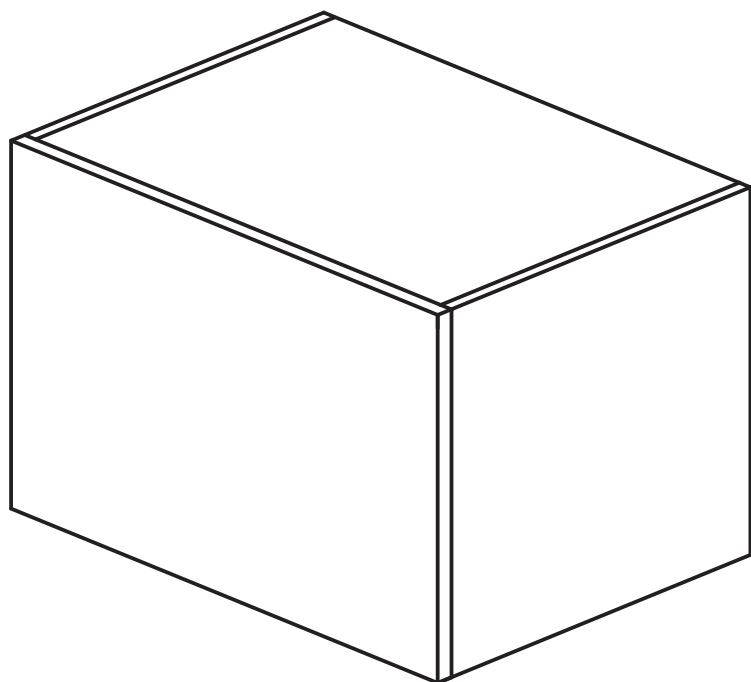
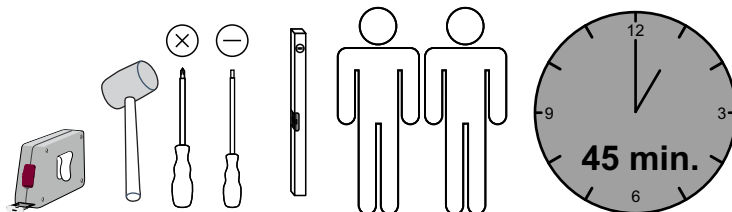

**D** – bitte lesen sie diese montageanleitung gut durch,  
Da wir für fehler, die durch falsche montage entstehen,  
Keine haftung übernehmen!

**Gb** – please read these installation instructions  
Through carefully as we cannot accept any liability  
For faults occurring as a result of incorrect installation!

**Cz** – přečtěte si prosím pozorně tento návod k montáži,  
Aby jste předešli chybám vzniklých špatnou montáží,  
Za které neručíme!

**F** – veuillez lire attentivement cette notice de montage,  
Car nous déclinons toute responsabilité en cas d'erreurs  
Découlant d'un montage erroné !

**I** – prego leggere attentamente le istruzioni per il montaggio,  
Poiché decliniamo qualsiasi responsabilità  
Per difetti derivanti da montaggio errato.

**S** - läs monteringsanvisningarna noggrant.  
Vi avsåger oss allt ansvar för defekter som  
Uppstår p.g.a. Felaktig montering.

**Hr** – pažljivo pročitajte upute za montažu,  
Jer otklanjamo svaku odgovornost za pogreške  
Nastale uslijed pogrešne montaže.

**Slo** – prosimo, da pozorno preberete navodila za montažo,  
Saj zavračamo vsakršno odgovornost za napake,  
Ki bi nastale zaradi napačne montaže.

**Nl** – leest u alstublieft deze montagehandleiding goed door,  
Voor fouten door verkeerde montage zijn wij niet verantwoordelijk.

**Pl** – prosze uwaznie zapoznac sie z instrukcja montazu,  
Poniewaz nie ponosimy odpowiedzialnosci za niewlasciwy montaz.

**HU** – Kérjük, olvassa el figyelmesen  
ezt az összeszerelési útmutatót,  
mert a helytelen összeszerelésből  
a dódó hibákért nem vállalunk felelősséget!

**SK** – Prosíme, dobre prečítajte si tento návod na montáž,  
pretože nepreberáme žiadne ručenie za chyby,  
ktoré vzniknú na základe chybnej montáže!

**RO** – Vă rugăm să cititi cu atenție aceste instructiuni  
de montaj deoarece nu preluăm garanția pentru defecte  
ce apar datorită unui montaj incorect!

**RUS** – Пожалуйста, внимательно ознакомьтесь ù  
с данной инструкцией по монтажу, поскольку мы не  
несем ответственности за ошибки, причиной которых  
является неправильный монтаж.

**TU** – İlkonce kullanma klavuzunu iyi okkuyun,  
yalnis montaj yapasaniz bunun sorumlusu biz degiliz.

**ES** – Se ruega leer con atención las instrucciones  
de montaje debido a que declinamos cualquier  
responsabilidad  
por defectos derivados de un montaje erróneo.

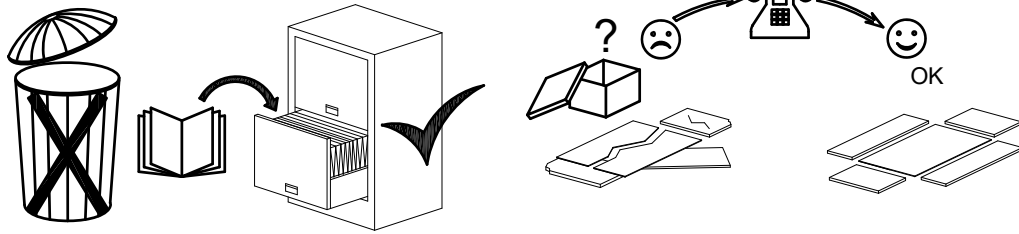

386mm.

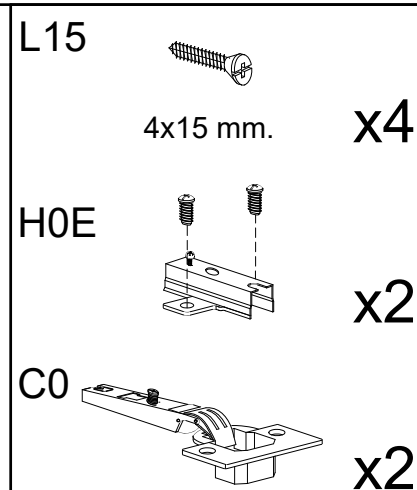
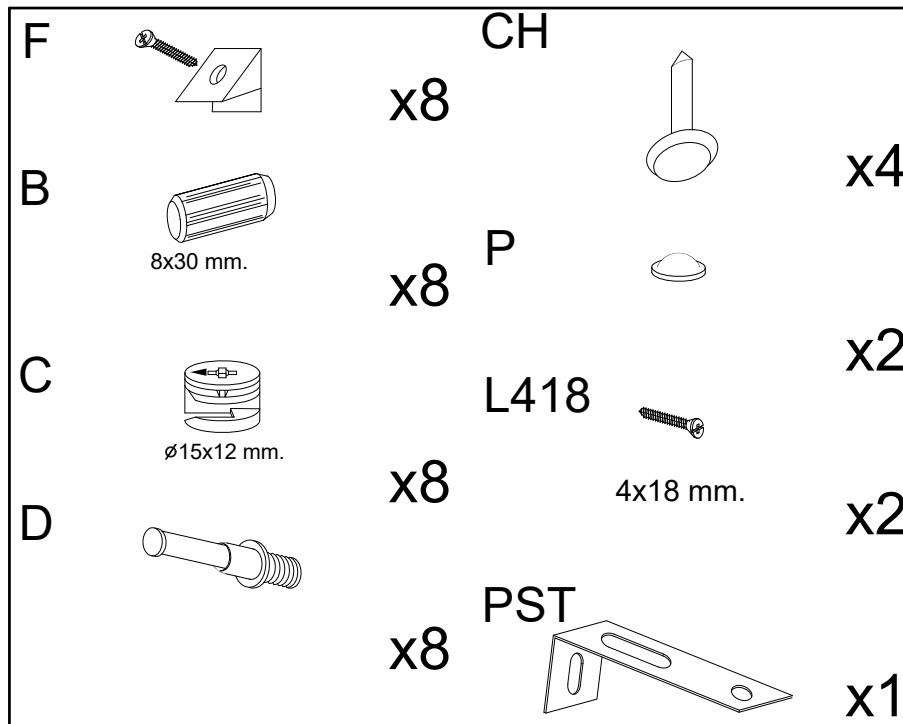
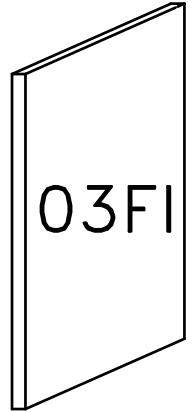
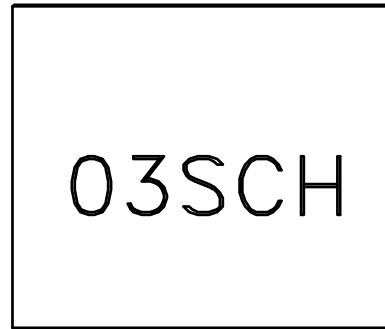
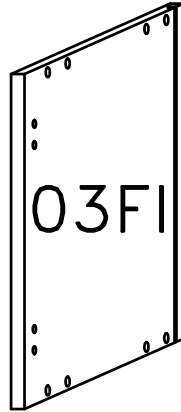

1

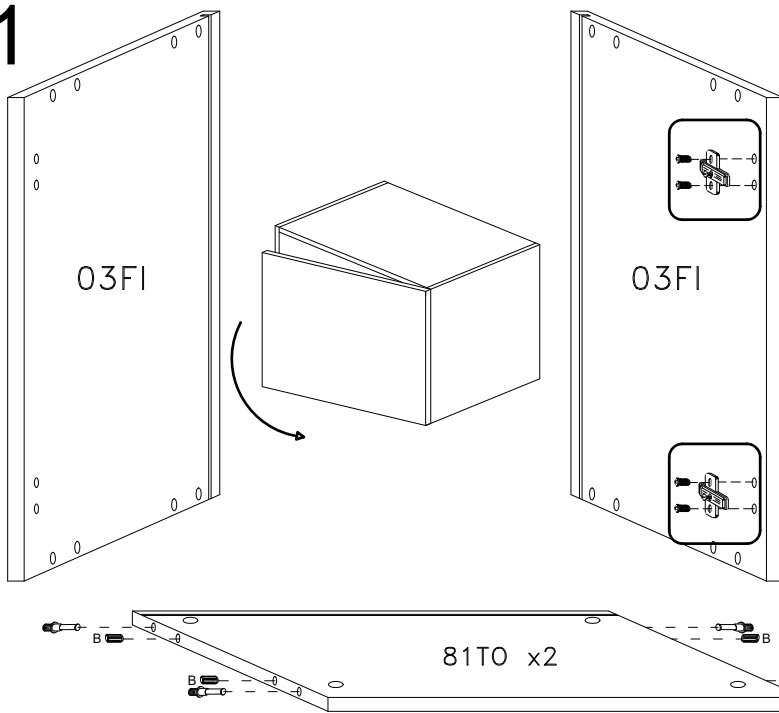

B



8x30 mm.

x8

D

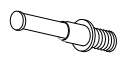

x8

C



15x12 mm.

x8

HOE

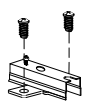

x2

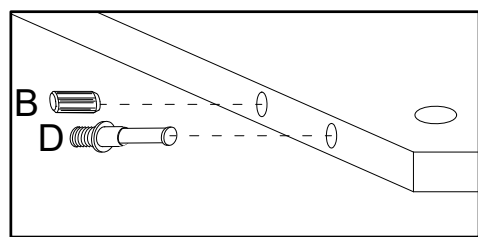
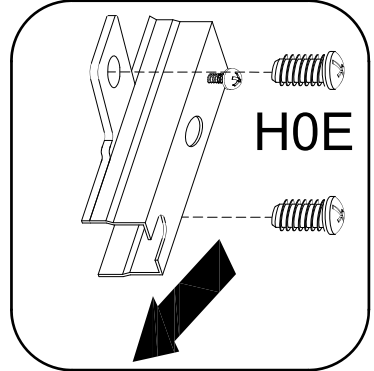

2

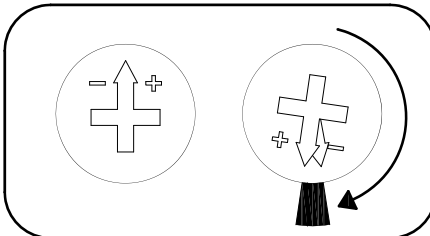
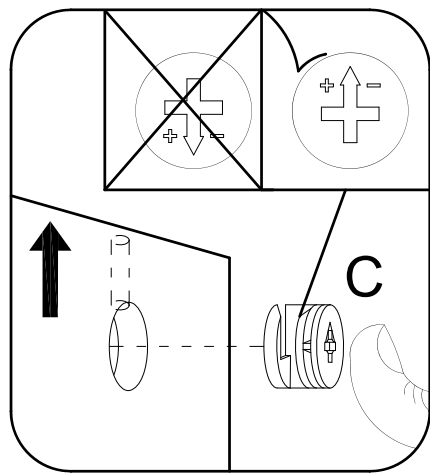
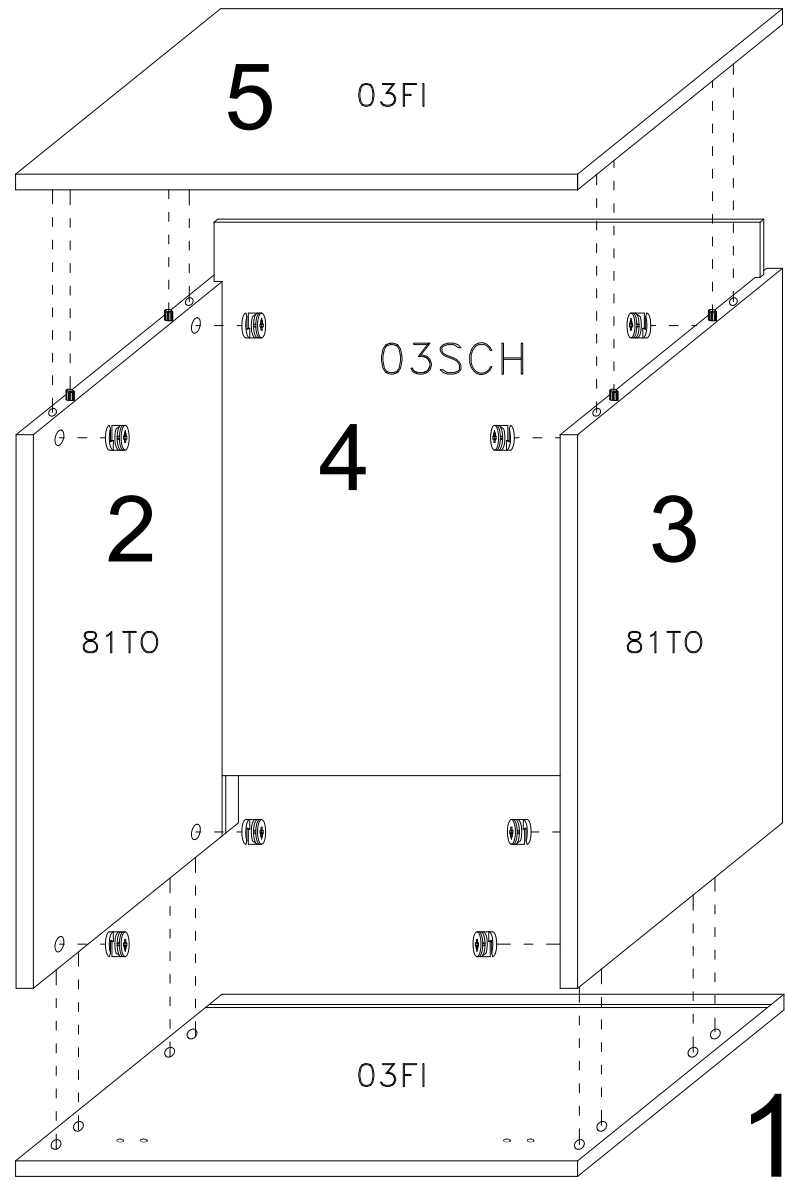

3

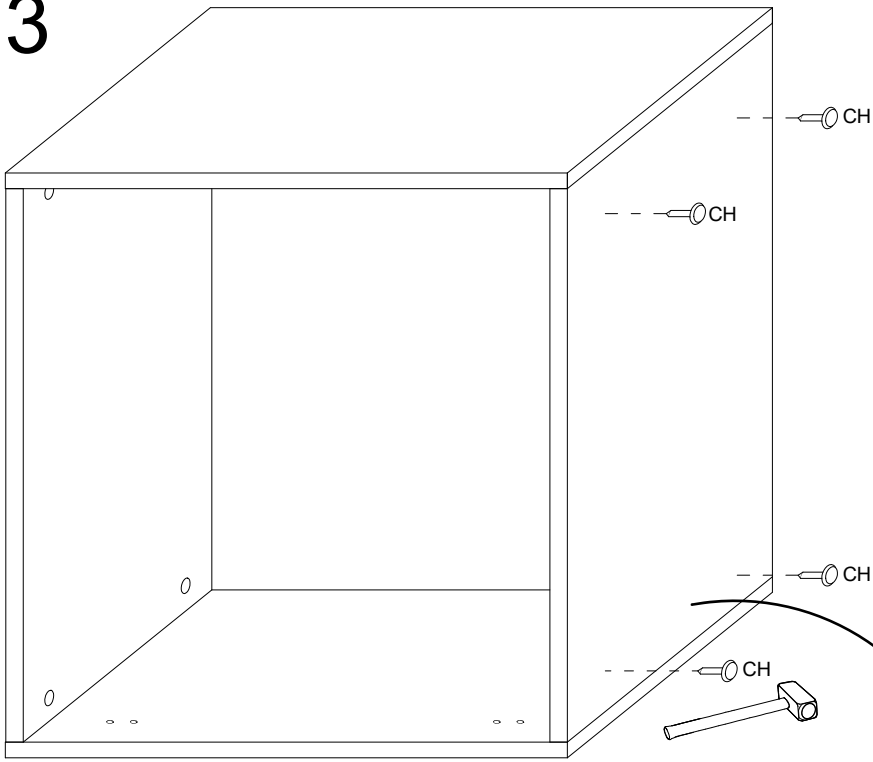

CH

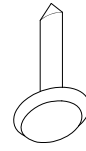

x4

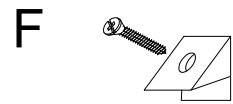
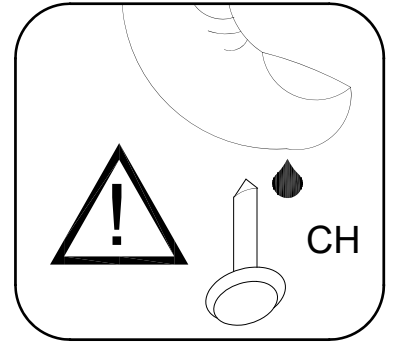

x8

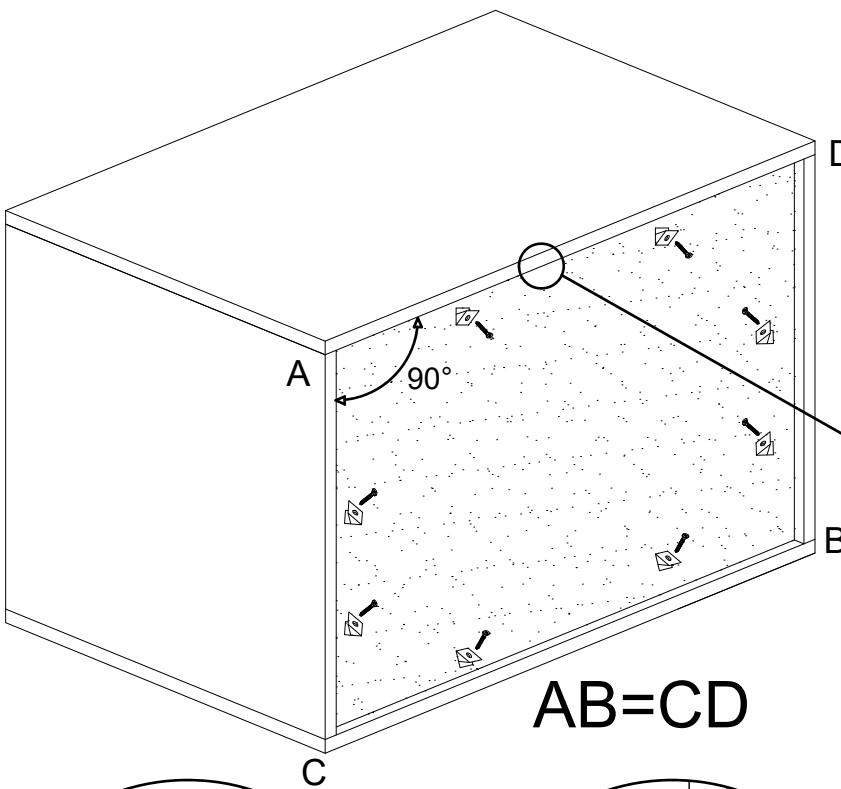

Ø8mm



8

15

AB=CD

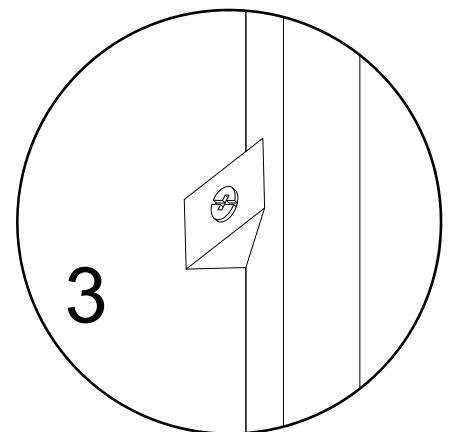
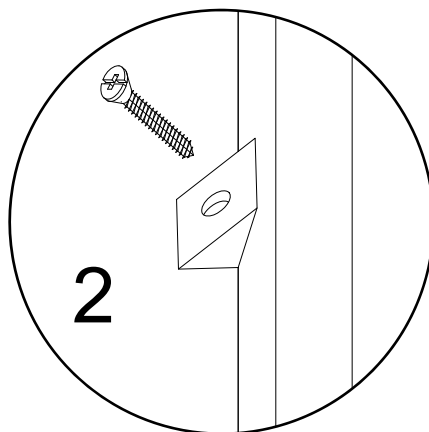
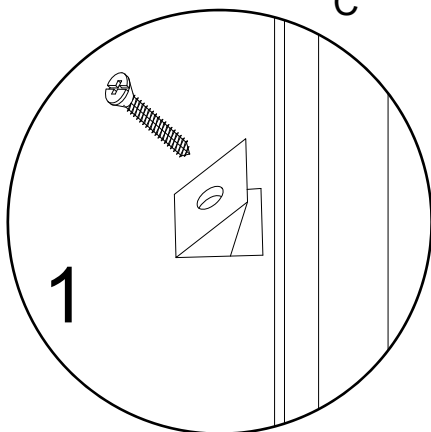

4

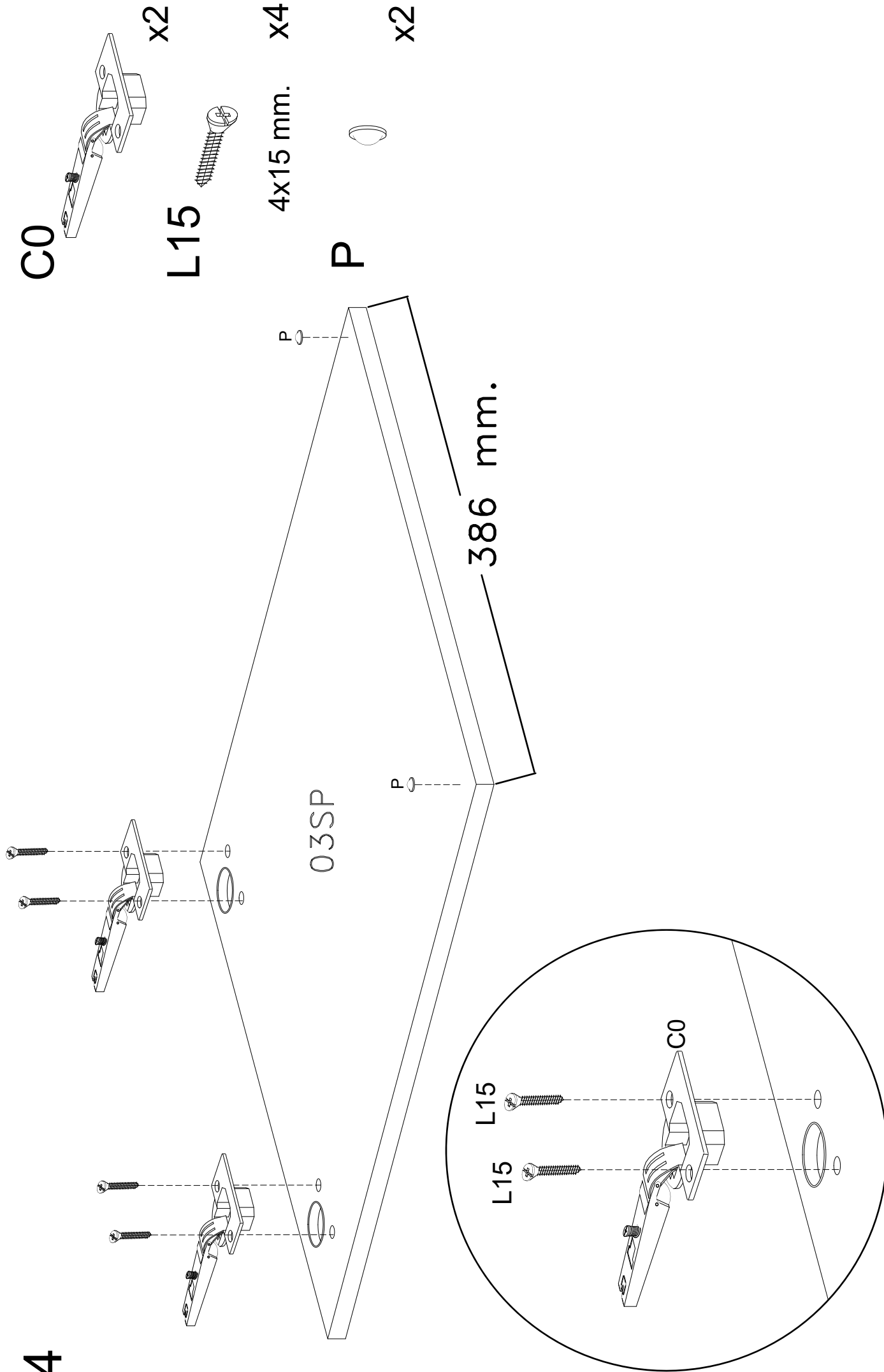



# 5

Gentile Cliente

Il montaggio dei pensili deve essere effettuato da personale competente.

I tasselli di fissaggio non sono compresi nella ferramenta.

Scegliere il tipo di tassello per il fissaggio più adatto alla tipologia di muro. Assicurarsi l'idoneità della parete per un sostegno sicuro del pensile.

Dear Customer,

The assembling of the hanging elements must be done by a competent staff. The wall plugs are not included in the hardware package.

Choose the wall plugs more suitable to the type of the wall.

Ensure the suitability of the wall for a secure support of the hanging element.

Sehr geehrter Kunde, die Montage der Hängeelemente muss von Fachpersonal ausgeführt werden!

Bitte verwenden Sie eigene Dübel, die der Beschaffenheit der

Wand entsprechen. Zu Ihrer eigenen Sicherheit legen wir dem

Beschlagbeutel keine Dübel bei.

Cher client, les éléments muraux ne peuvent être installés que par du personnel qualifié!

Veillez utiliser vos propres ancrages adaptés à la nature du mur.

Pour votre sécurité, nous n'incluons pas de chevilles dans le matériel.

Estimado cliente, el montaje de los muebles colgados en la pared debe ser realizado por personal competente. Los tacos de fijación no están incluidos en la bolsa de herrajes. Elija el tipo de anclaje de fijación que mejor se adapte al tipo de pared. Asegúrese de que la pared sea adecuada para un soporte seguro del mueble colgado en la pared.

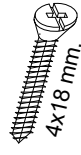
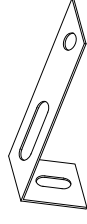

## PST x1 L418 x2

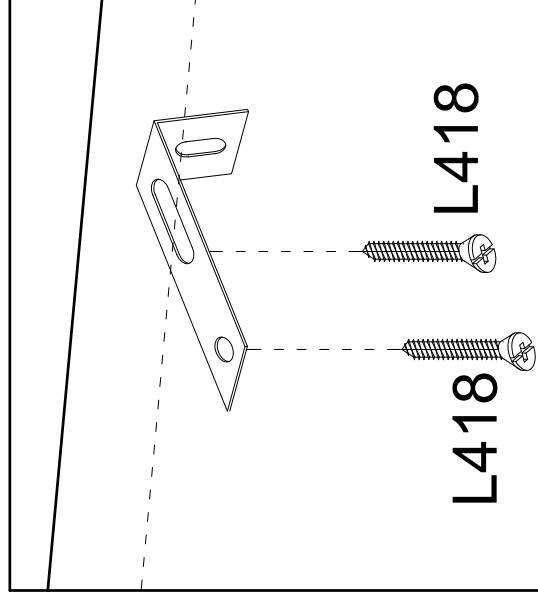
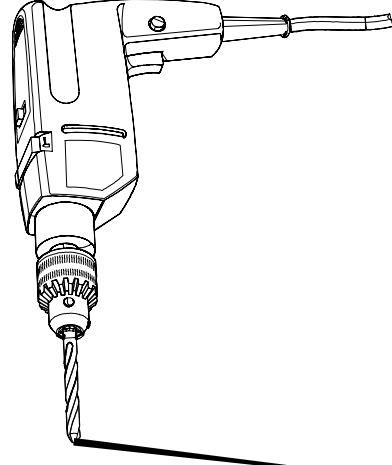

274 mm.

274 mm.

366 mm.

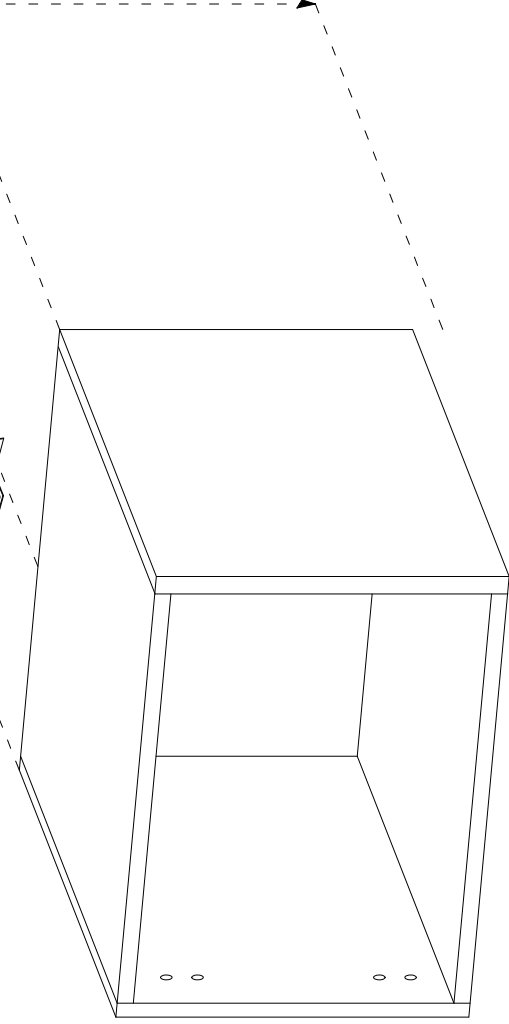

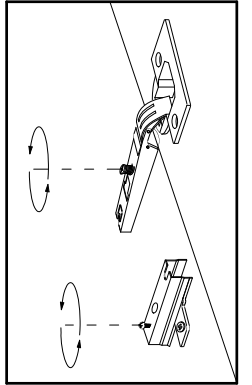
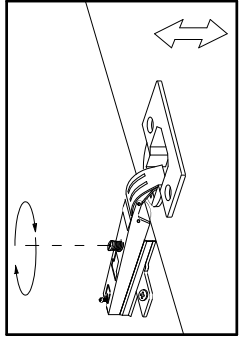
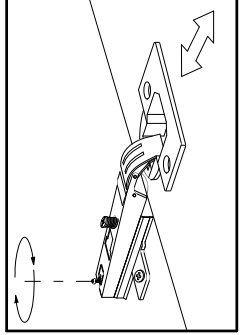
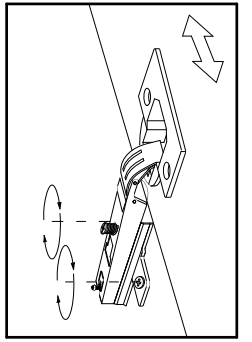
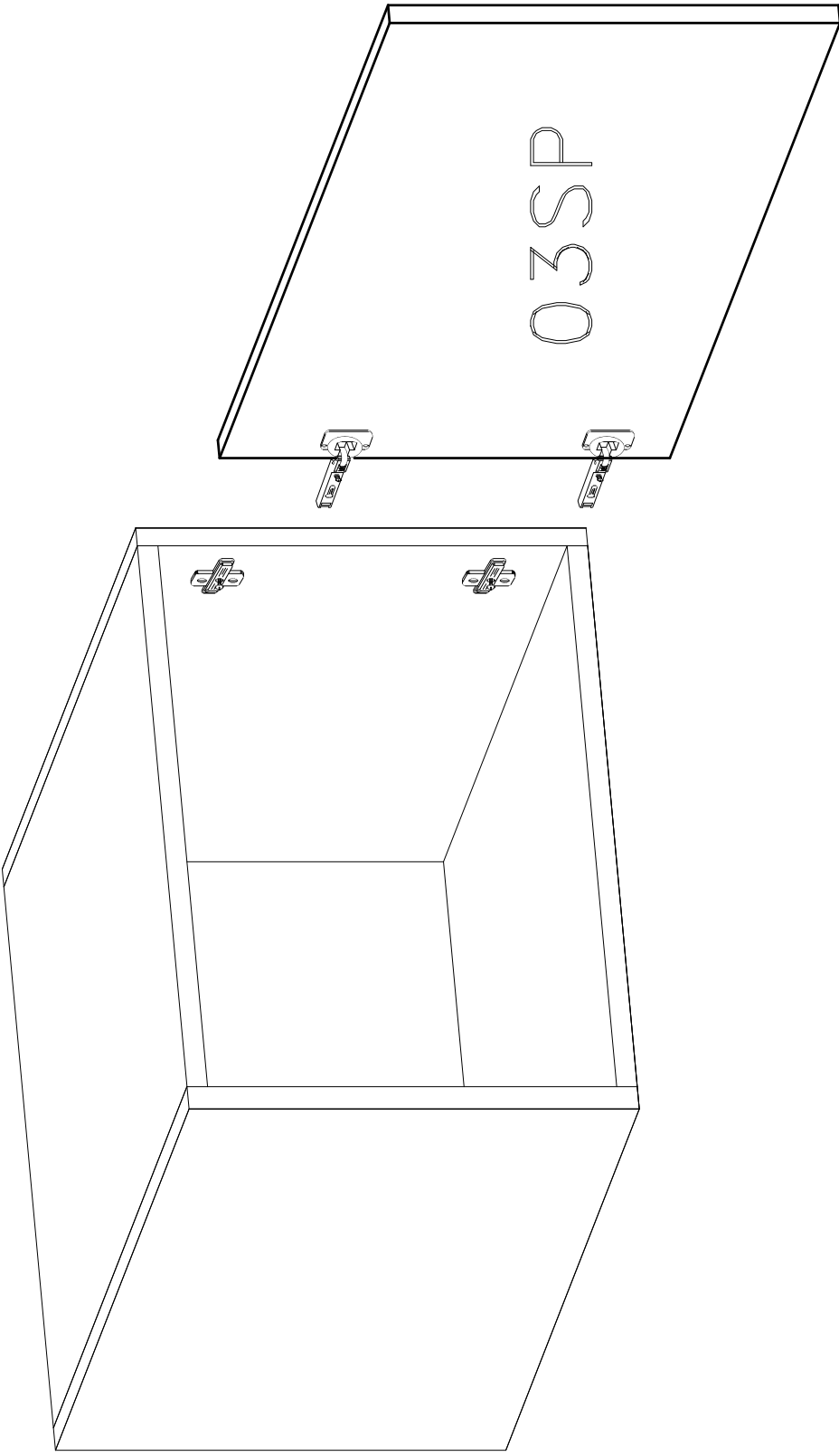

# -81

Montageanweisung / Installation instructions / Instruction de montage / Istruzioni di montaggio  
montagehandleiding / Instrukcja montazu / Montaj talimatlar / Osszeszerelési útmutató / Nàvod k montázi /  
Nàvod na montaz / Instructiune de montaj / Инструкция по монтажу / Montaj talimatina / Monteringsanvisningar  
Upute za montažu / Instrucciones de Montaje / Navodila za montažo

# INFINITY 2.0

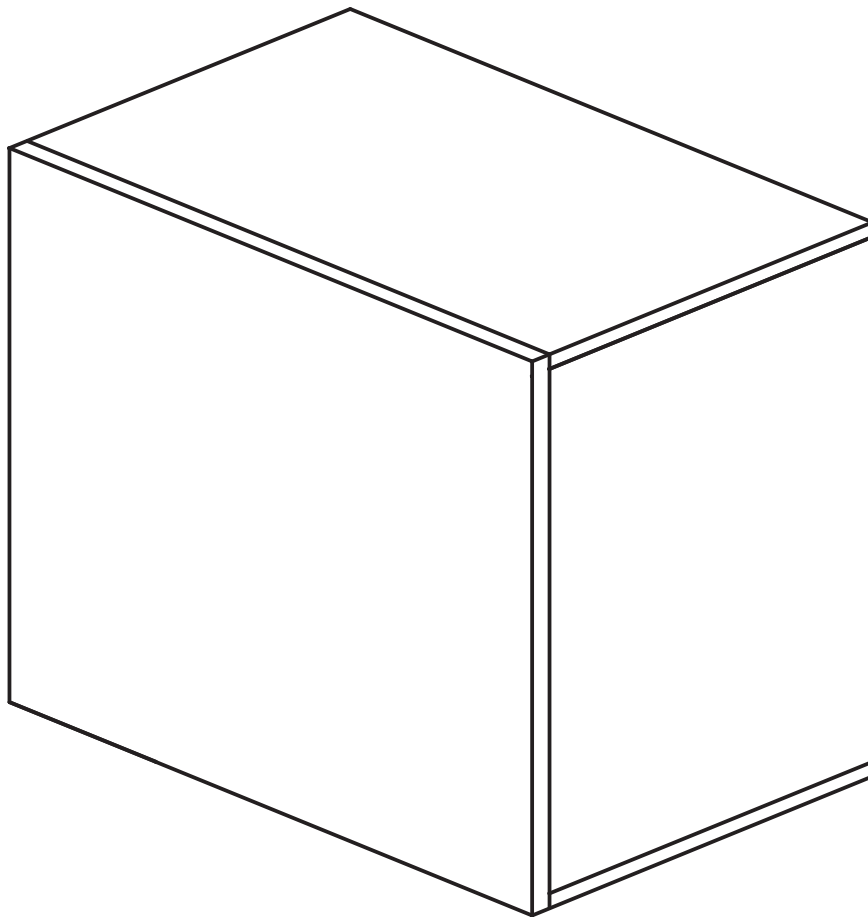
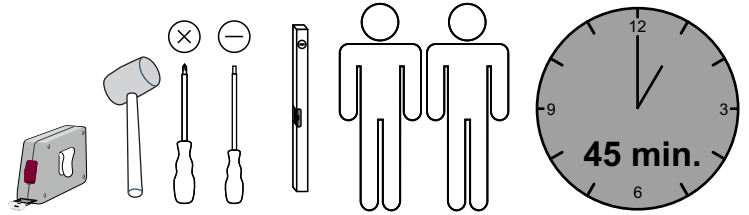

**D** – bitte lesen sie diese montageanleitung gut durch,  
Da wir für fehler, die durch falsche montage entstehen,  
Keine haftung übernehmen!

**Gb** – please read these installation instructions  
Through carefully as we cannot accept any liability  
For faults occurring as a result of incorrect installation!

**Cz** – přečtěte si prosím pozorně tento návod k montáži,  
Aby jste předešli chybám vzniklých špatnou montáží,  
Za které neručíme!

**F** – veuillez lire attentivement cette notice de montage,  
Car nous déclinons toute responsabilité en cas d'erreurs  
Découlant d'un montage erroné !

**I** – prego leggere attentamente le istruzioni per il montaggio,  
Poiché decliniamo qualsiasi responsabilità  
Per difetti derivanti da montaggio errato.

**S** - läs monteringsanvisningarna noggrant.  
Vi avsåger oss allt ansvar för defekter som  
Uppstår p.g.a. Felaktig montering.

**Hr** – pažljivo pročitajte upute za montažu,  
Jer otklanjamo svaku odgovornost za pogreške  
Nastale uslijed pogrešne montaže.

**Slo** – prosimo, da pozorno preberete navodila za montažo,  
Saj zavračamo vsakršno odgovornost za napake,  
Ki bi nastale zaradi napačne montaže.

**Nl** – leest u alstublieft deze montagehandleiding goed door,  
Voor fouten door verkeerde montage zijn wij niet verantwoordelijk.

**Pl** – prosze uwaznie zapoznac sie z instrukcja montazu,  
Poniewaz nie ponosimy odpowiedzialnosci za niewlasciwy montaz.

**HU** – Kérjük, olvassa el figyelmesen  
ezt az összeszerelési útmutatót,  
mert a helytelen összeszerelésből  
a dódó hibákért nem vállalunk felelősséget!

**SK** – Prosíme, dobre prečítajte si tento návod na montáž,  
pretože nepreberáme žiadne ručenie za chyby,  
ktoré vzniknú na základe chybnej montáže!

**RO** – Vă rugăm să cititi cu atenție aceste instructiuni  
de montaj deoarece nu preluăm garanția pentru defecte  
ce apar datorită unui montaj incorect!

**RUS** – Пожалуйста, внимательно ознакомьтесь ù  
с данной инструкцией по монтажу, поскольку мы не  
несем ответственности за ошибки, причиной которых  
является неправильный монтаж.

**TU** – İlkonce kullanma klavuzunu iyi okkuyun,  
yalnis montaj yapasaniz bunun sorumlusu biz degiliz.

**ES** – Se ruega leer con atención las instrucciones  
de montaje debido a que declinamos cualquier  
responsabilidad  
por defectos derivados de un montaje erróneo.

LC S.p.A  
Via del Piano s.n  
61030 Isola del Piano (PU)  
Italia  
<http://www.lcmobili.com/>



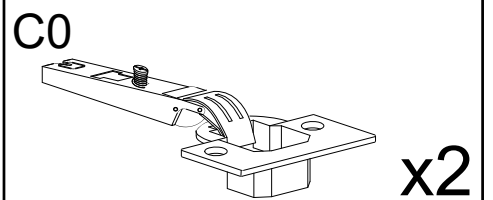
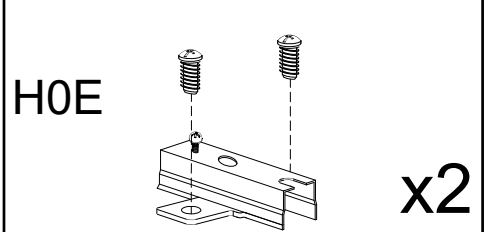
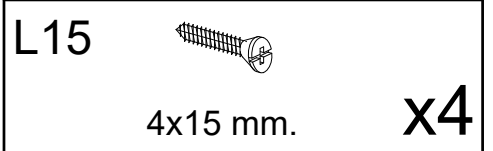
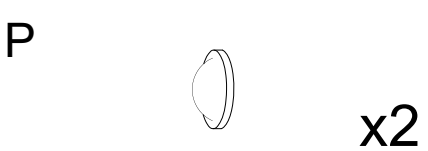
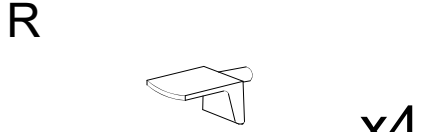
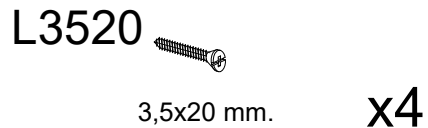
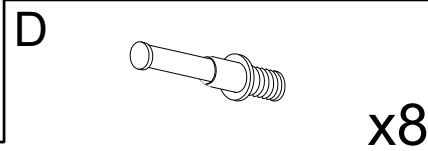
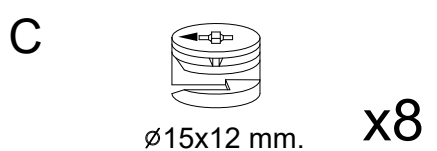
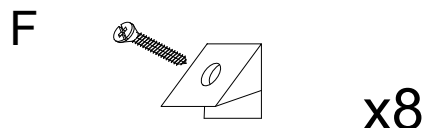
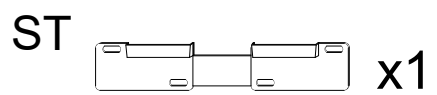
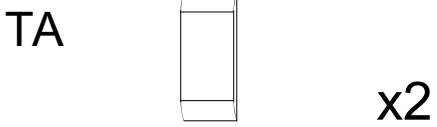
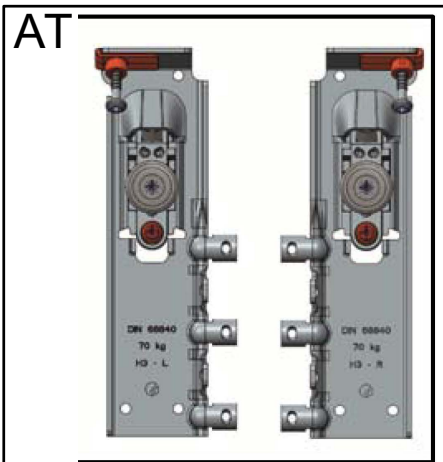
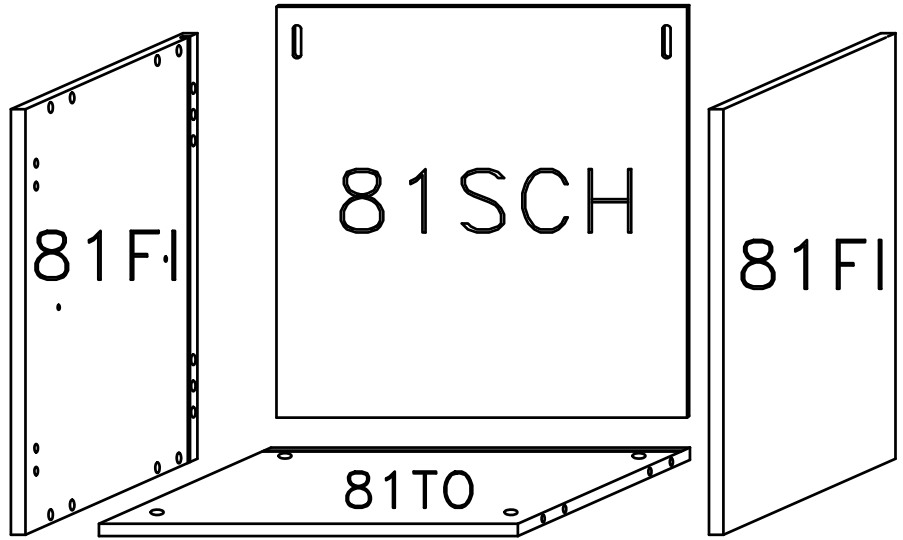
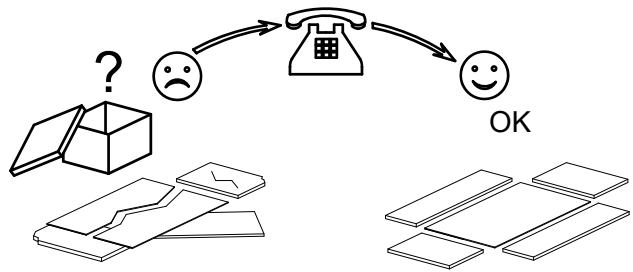
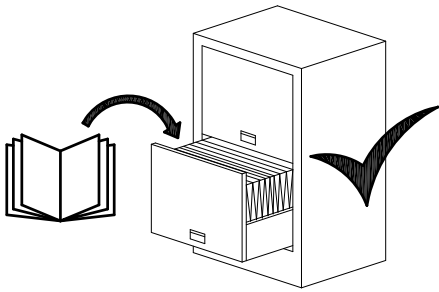
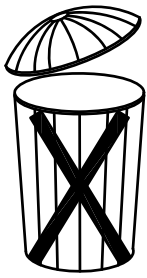

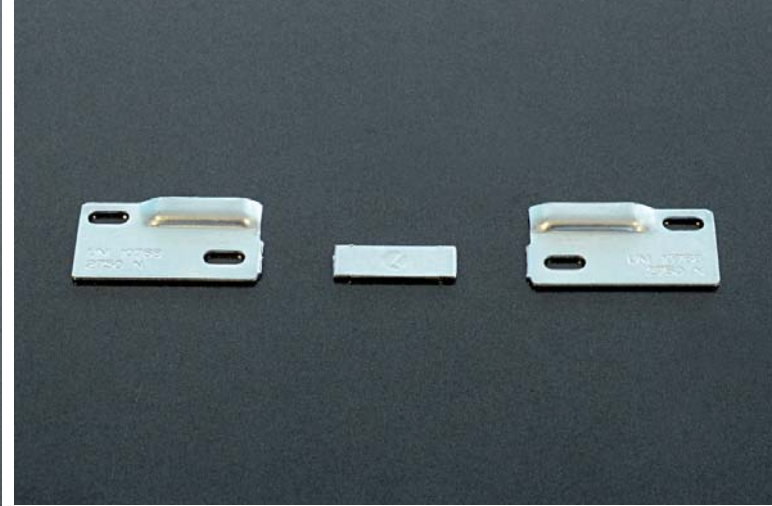
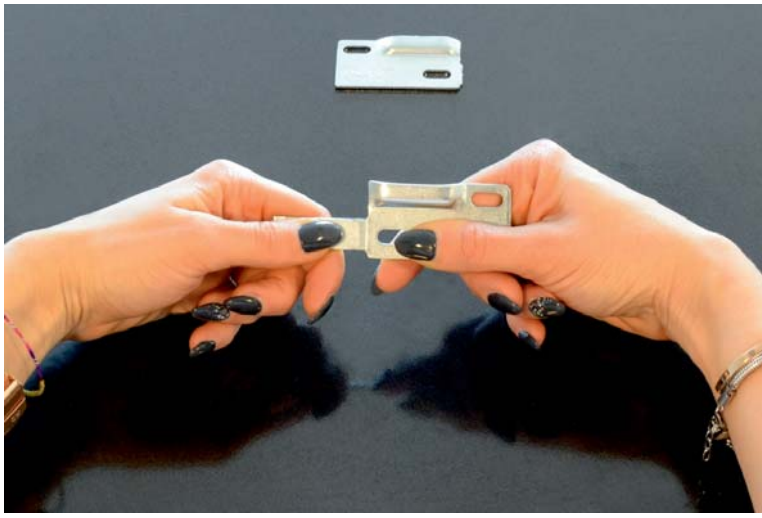
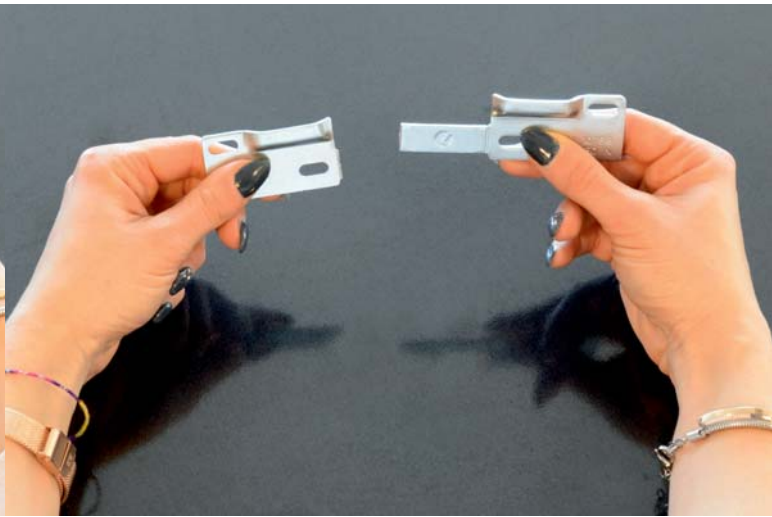
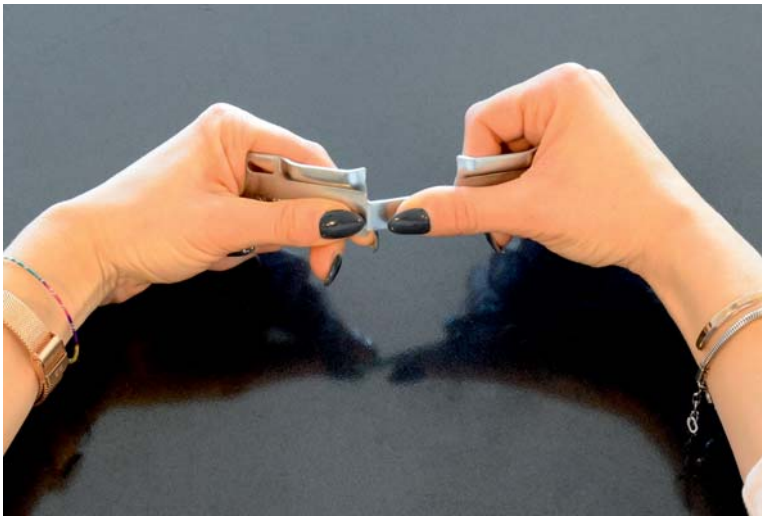
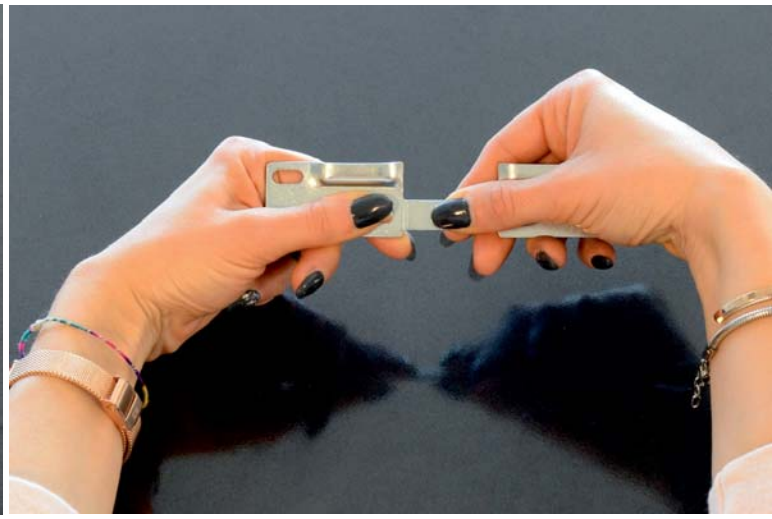
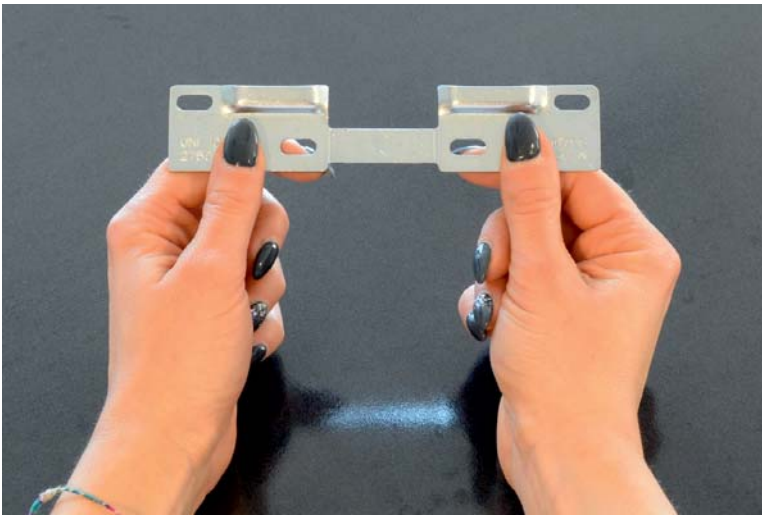

1

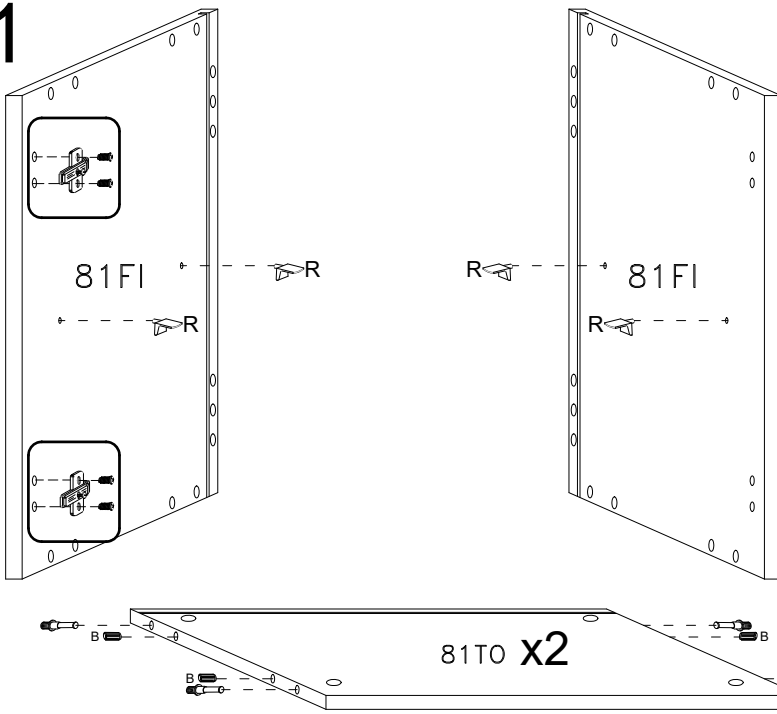

B

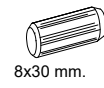

8x30 mm.

x8

C



ø16 mm.

x8

D

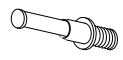

x8

H0E



x2

R



x4

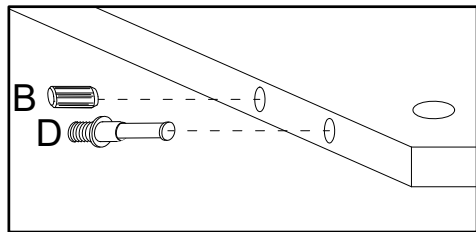
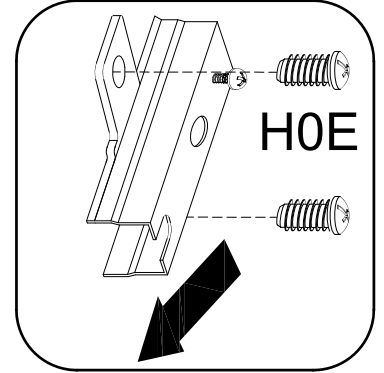

2

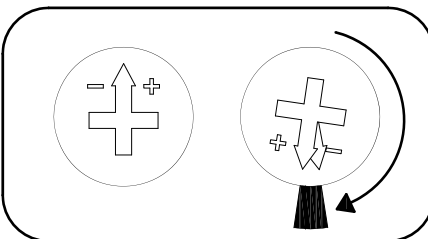
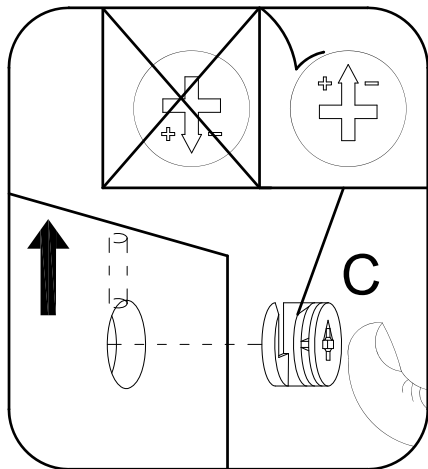
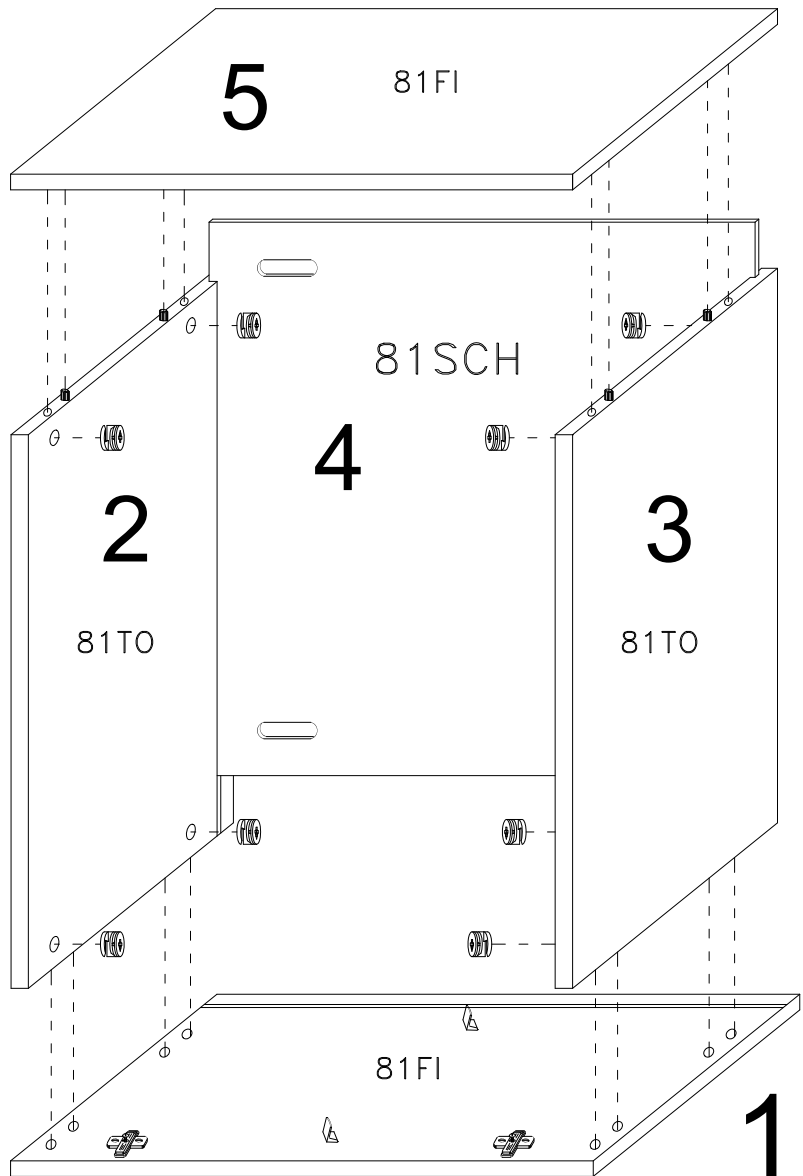

3

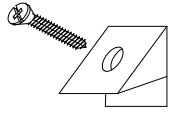
F  x8

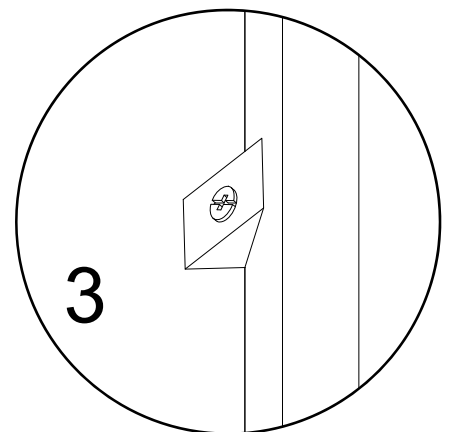
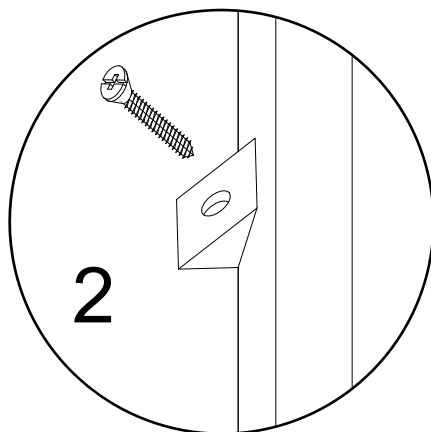
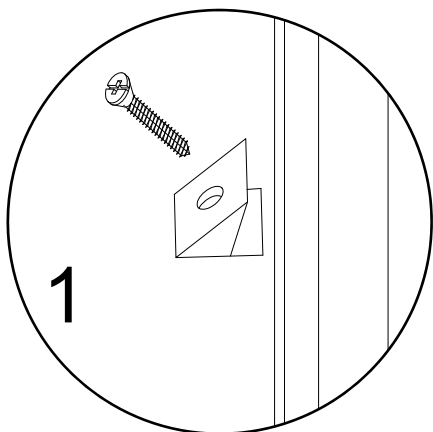
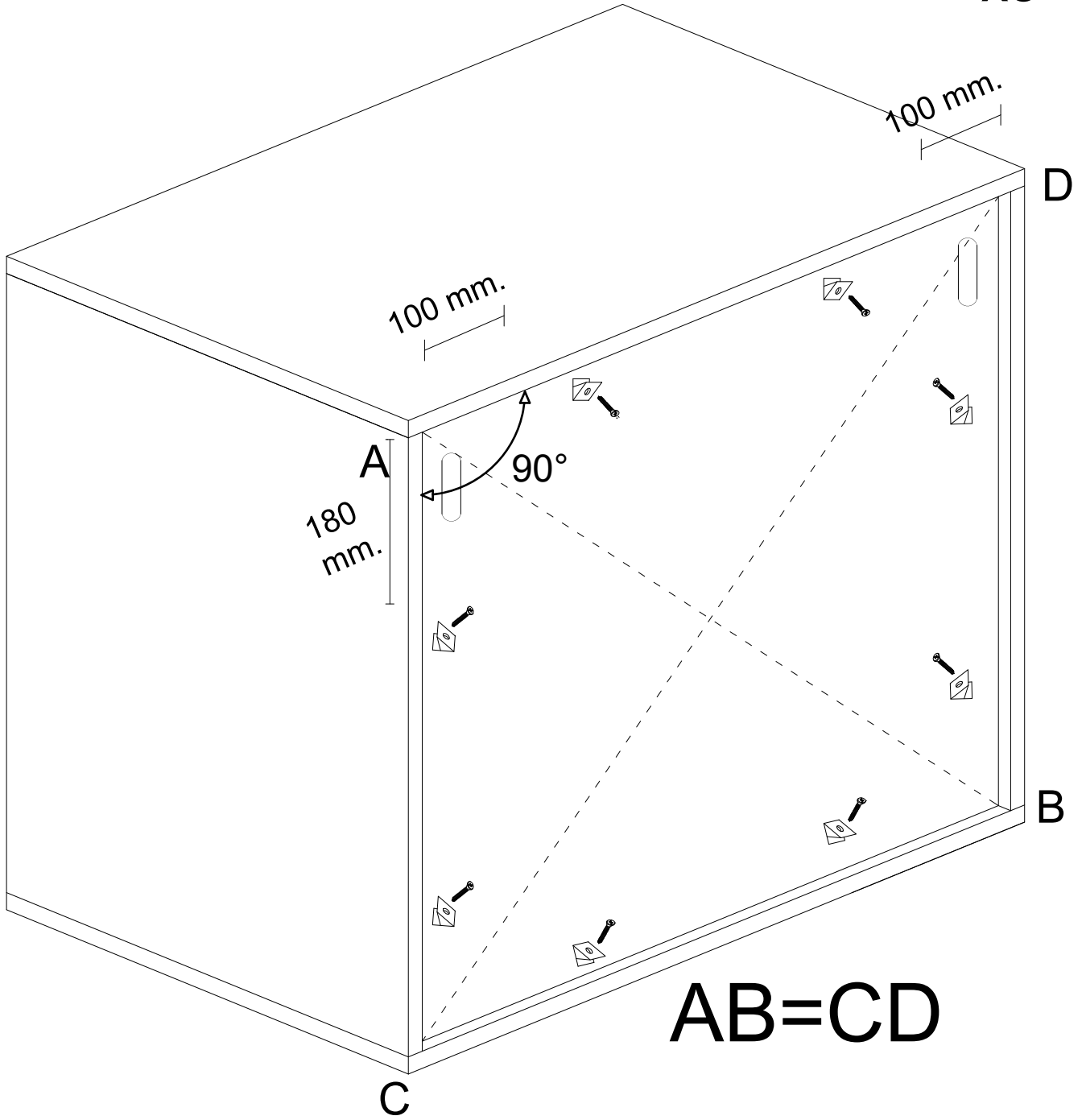



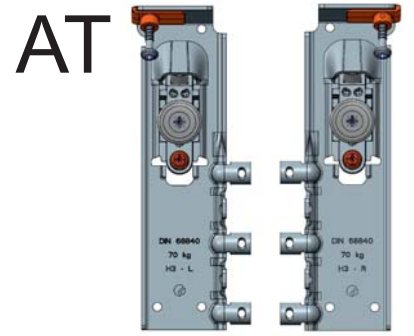
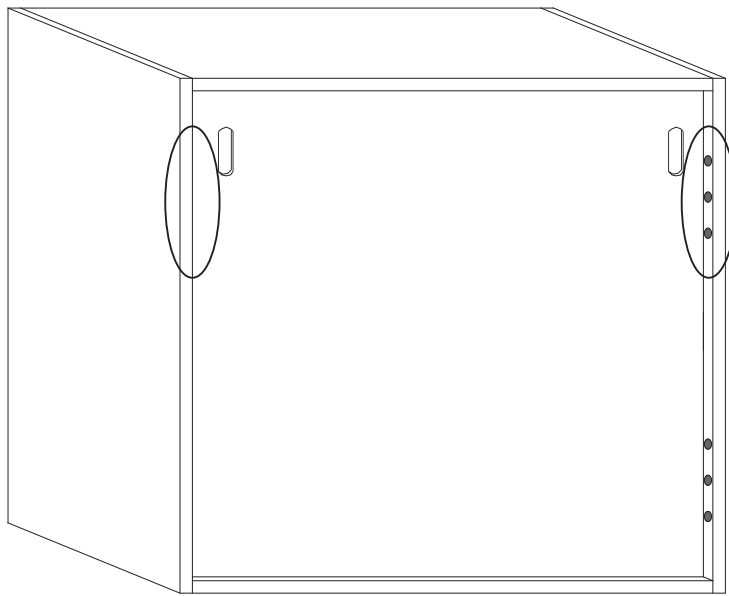

L3520



3,5x20 mm. **x4**

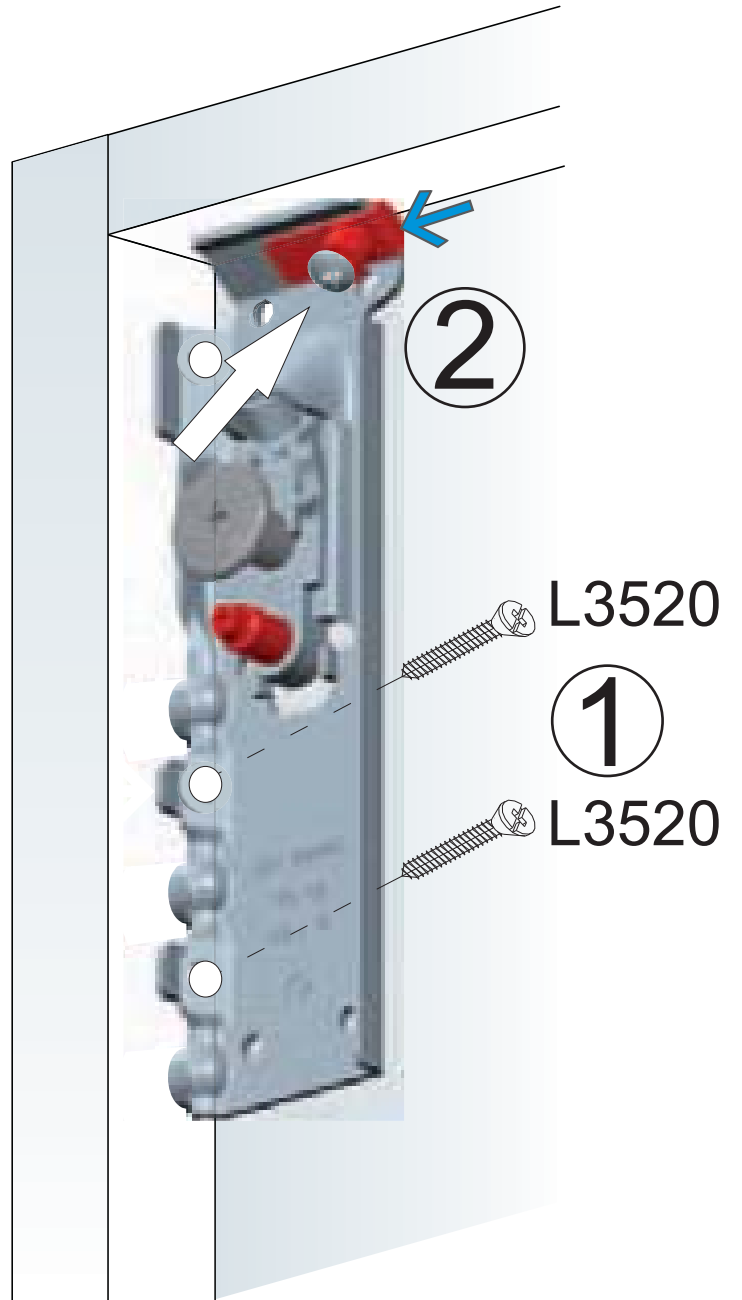
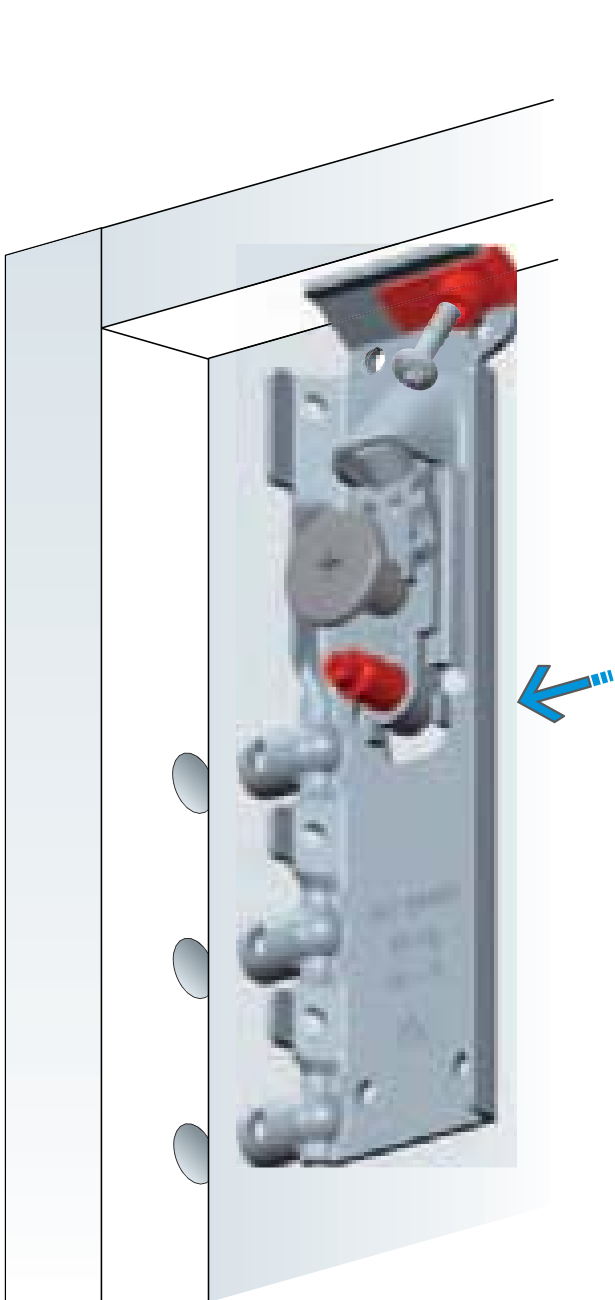





ST



x1

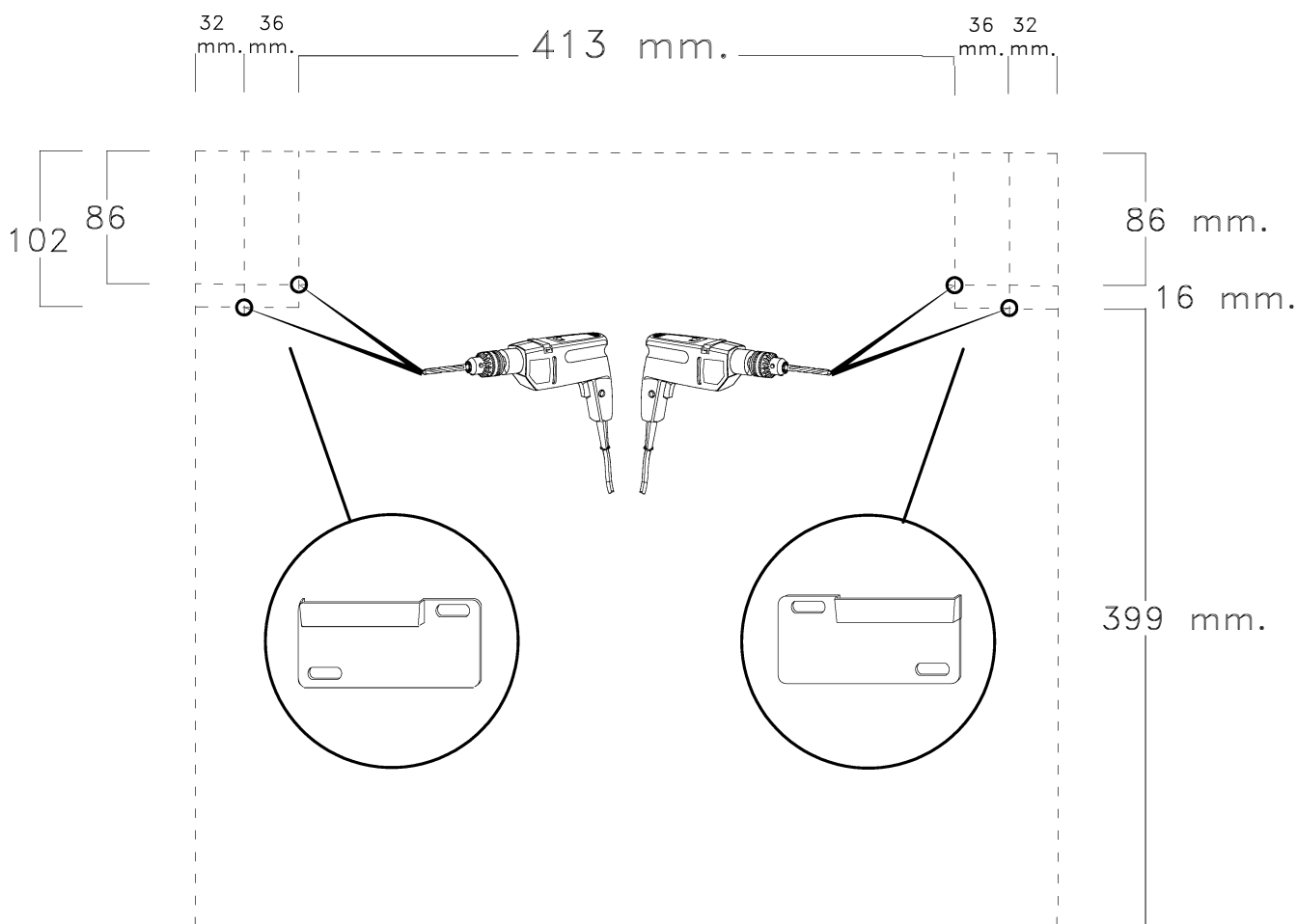

Gentile Cliente

Il montaggio dei pensili deve essere effettuato da personale competente. I tasselli di fissaggio non sono compresi nella ferramenta. Scegliere il tipo di tassello per il fissaggio più adatto alla tipologia di muro. Assicurarsi l'idoneità della parete per un sostegno sicuro del pensile.

Dear Customer,

The assembling of the hanging elements must be done by a competent staff. The wall plugs are not included in the hardware package. Choose the wall plugs more suitable to the type of the wall. Ensure the suitability of the wall for a secure support of the hanging element.

Sehr geehrter Kunde, die Montage der Hängeelemente muss von Fachpersonal ausgeführt werden!

Bitte verwenden Sie eigene Dübel, die der Beschaffenheit der Wand entsprechen. Zu Ihrer eigenen Sicherheit legen wir dem Beschlagbeutel keine Dübel bei.

Cher client, les éléments muraux ne peuvent être installés que par du personnel qualifié !

Veillez utiliser vos propres ancrages adaptés à la nature du mur. Pour votre sécurité, nous n'incluons pas de chevilles dans le matériel.

Estimado cliente, el montaje de los muebles colgados en la pared debe ser realizado por personal competente. Los tacos de fijación no están incluidos en la bolsa de herrajes. Elija el tipo de anclaje de fijación que mejor se adapte al tipo de pared. Asegúrese de que la pared sea adecuada para un soporte seguro del mueble colgado en la pared.

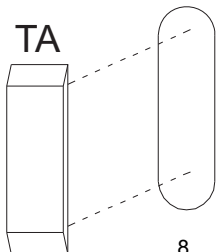
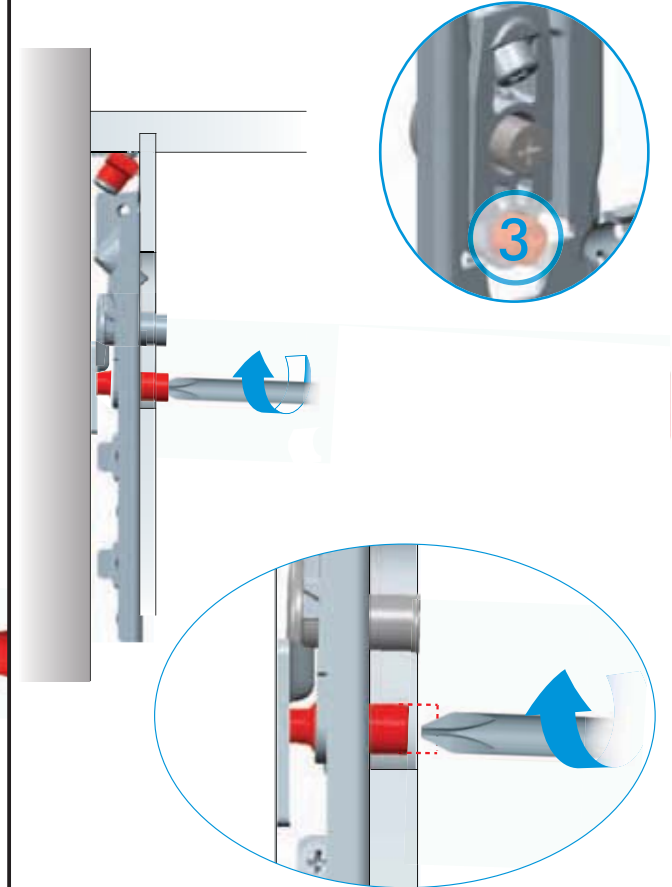
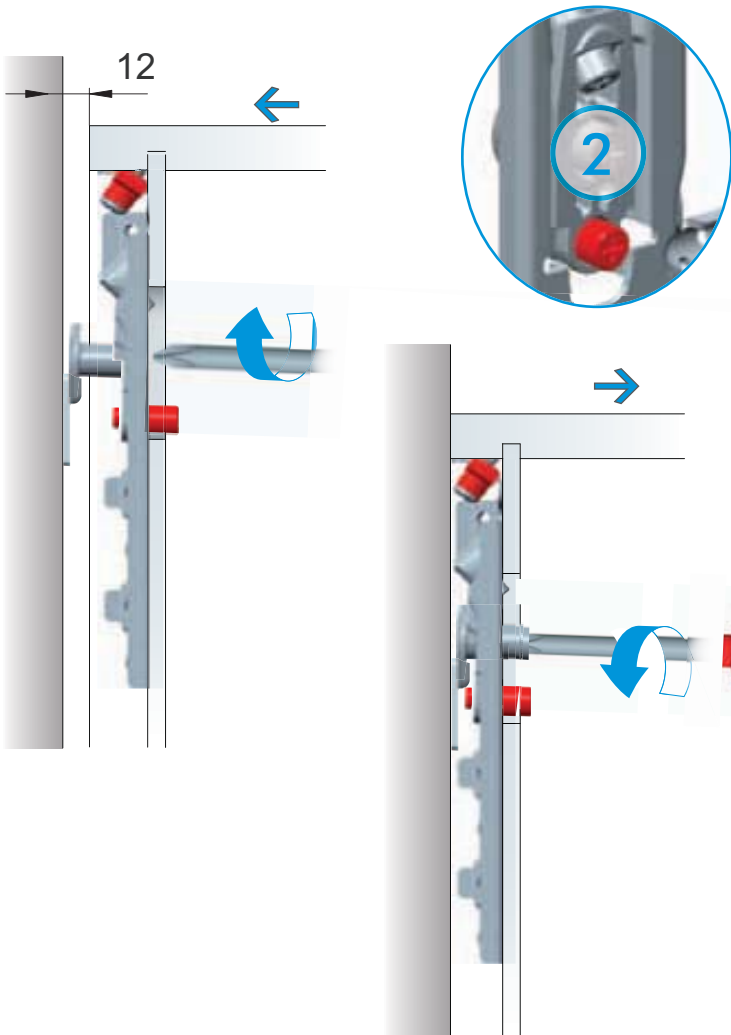
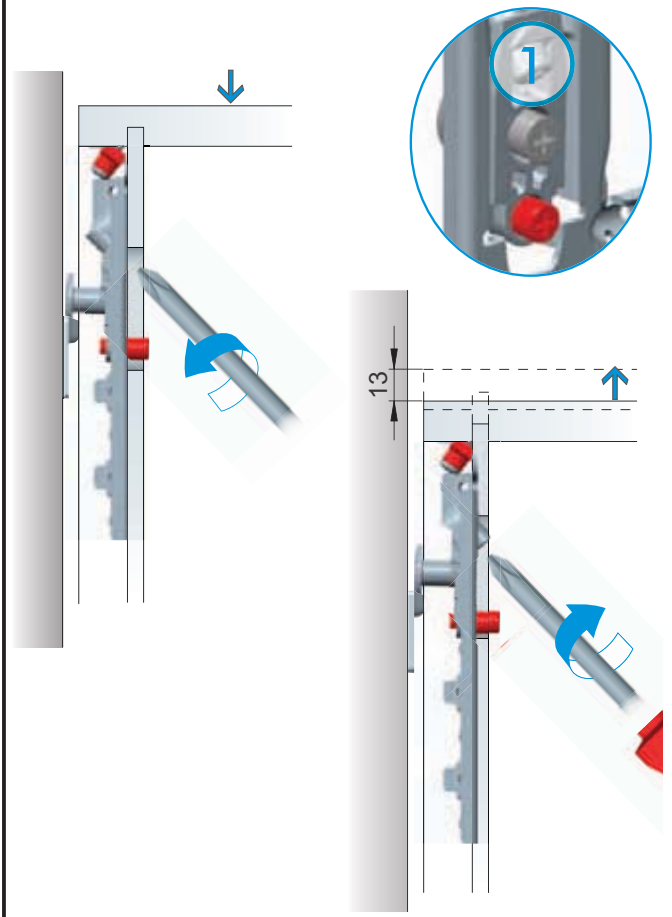
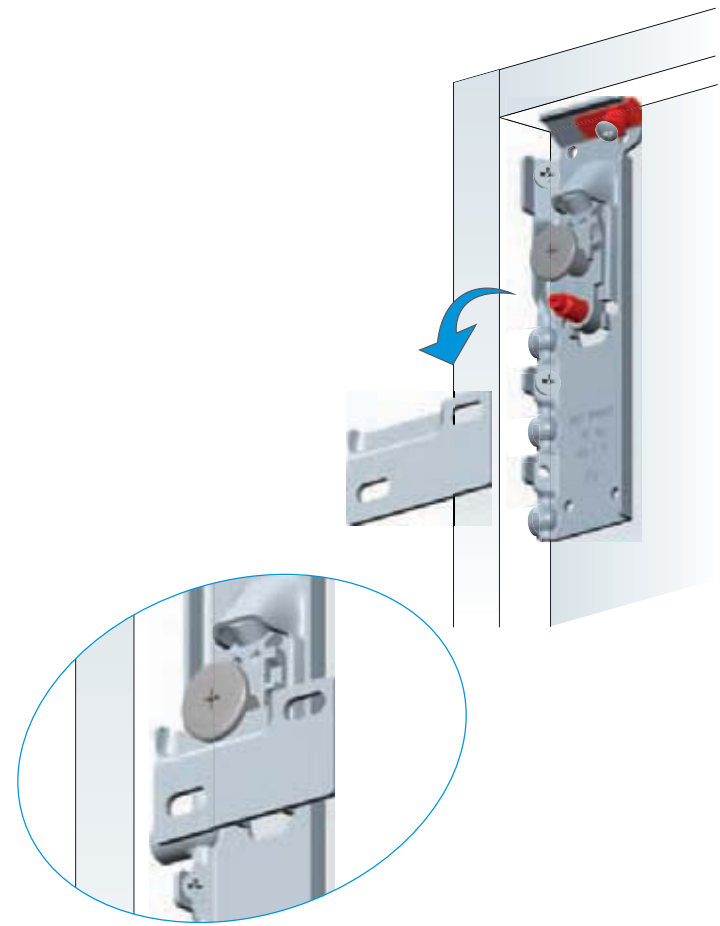

4

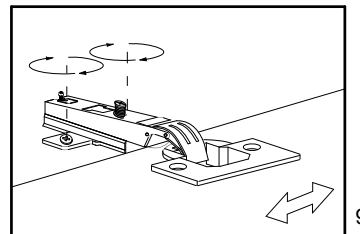
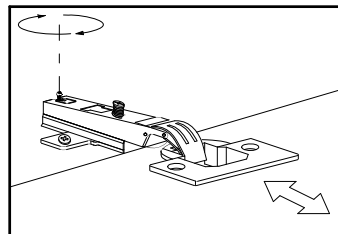
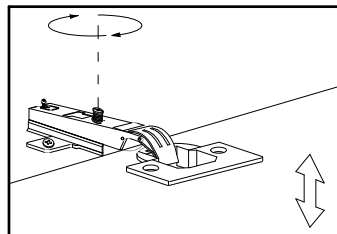
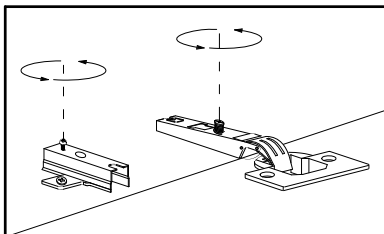
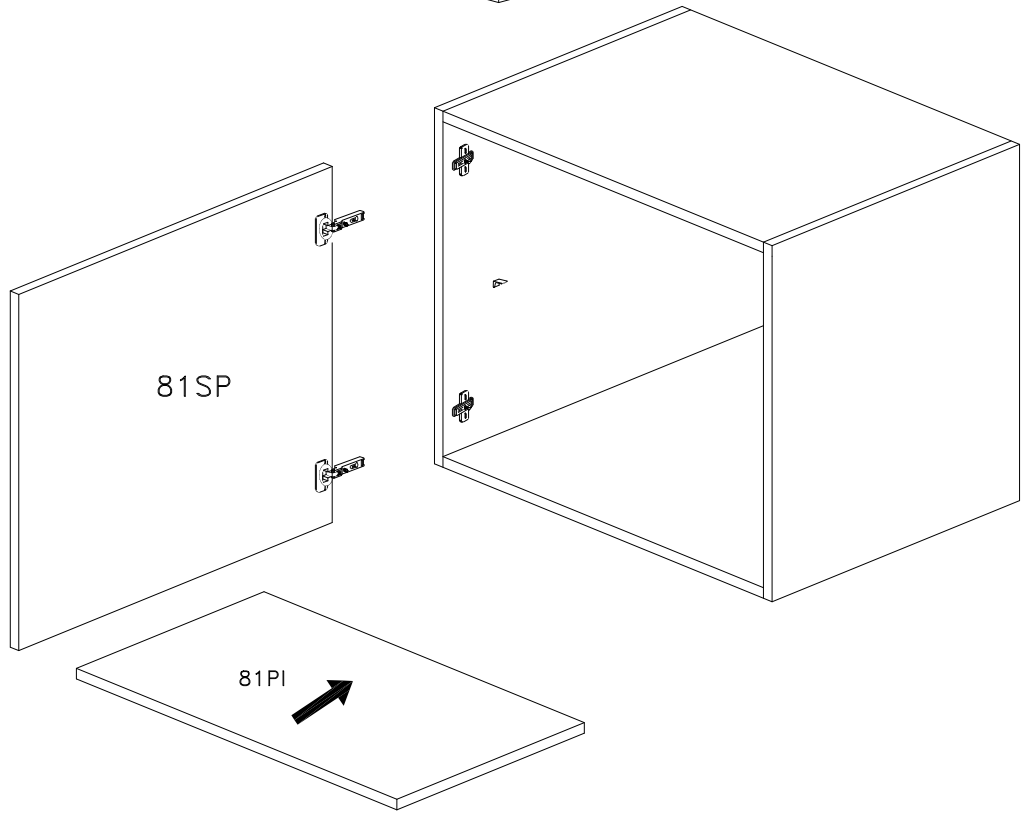
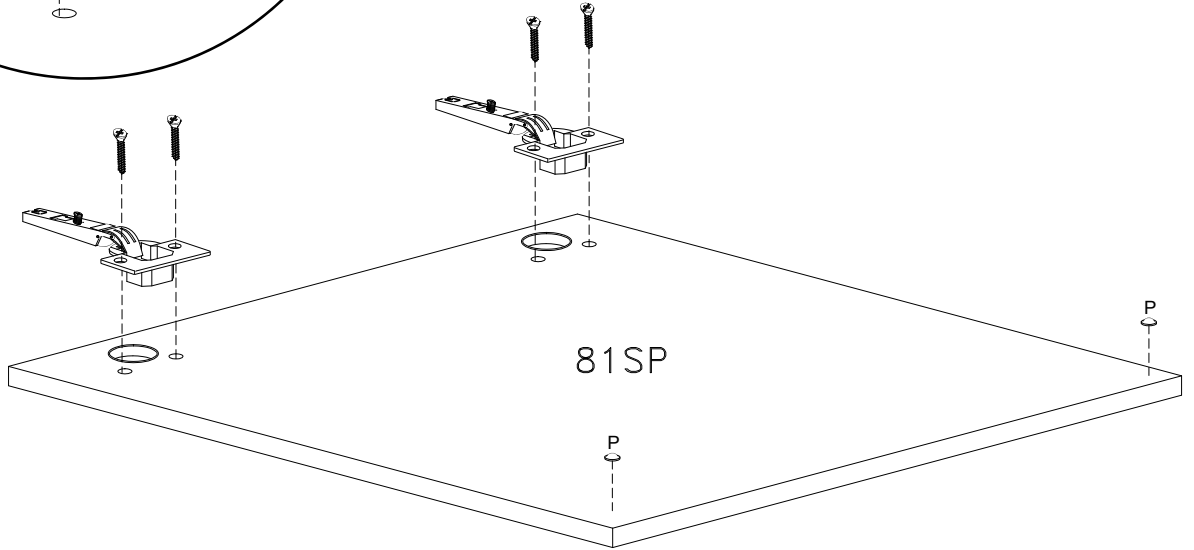
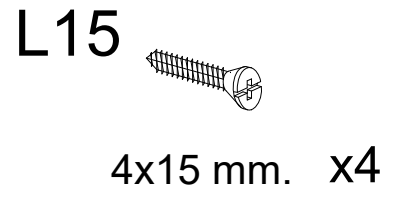
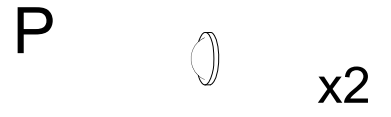
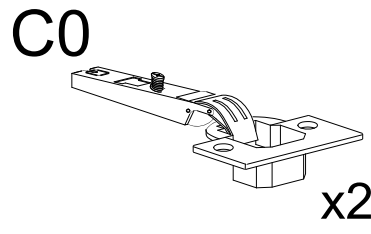
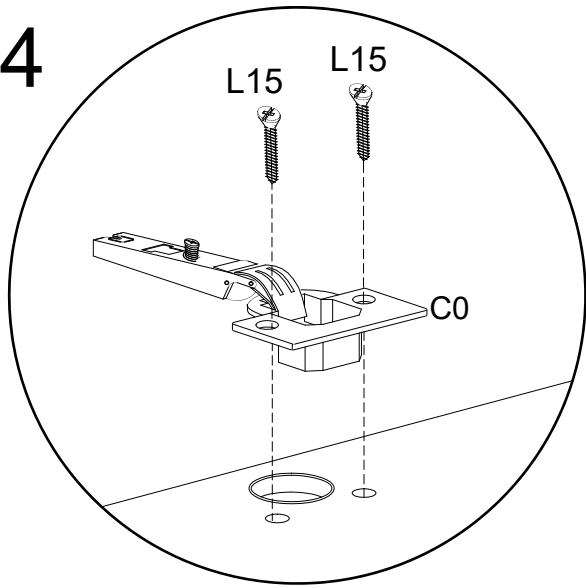

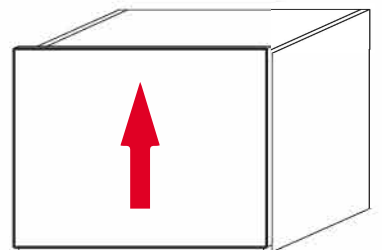
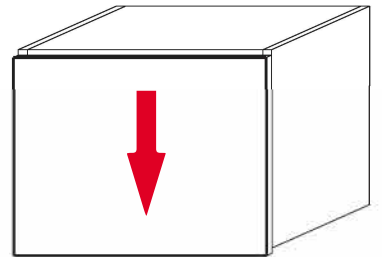
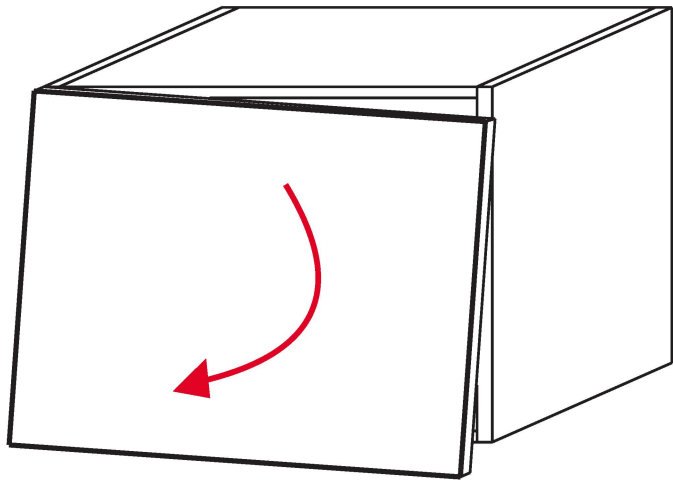
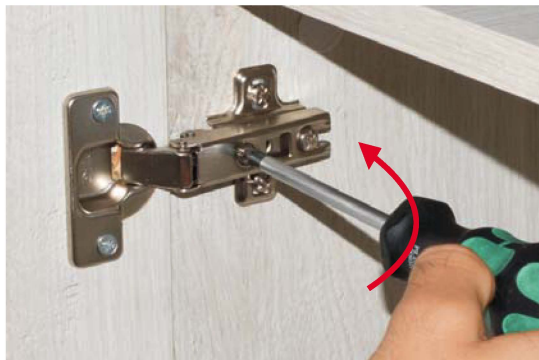
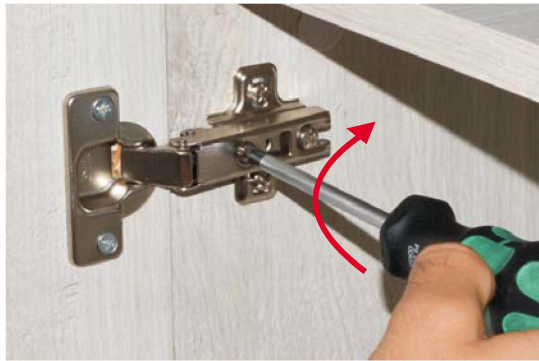
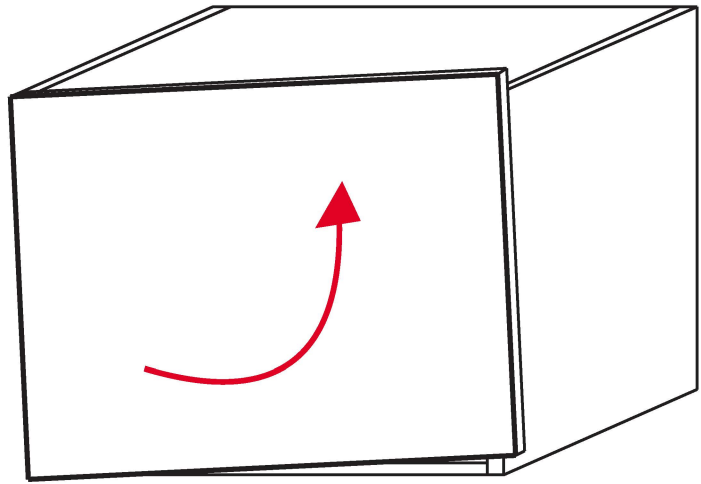
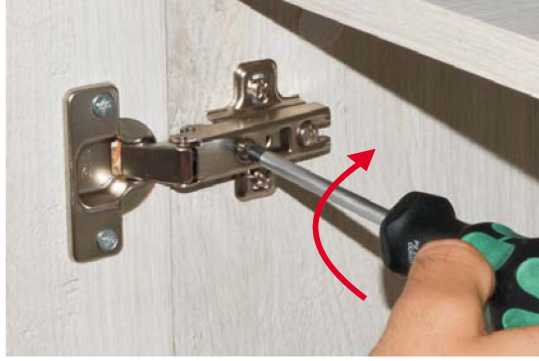
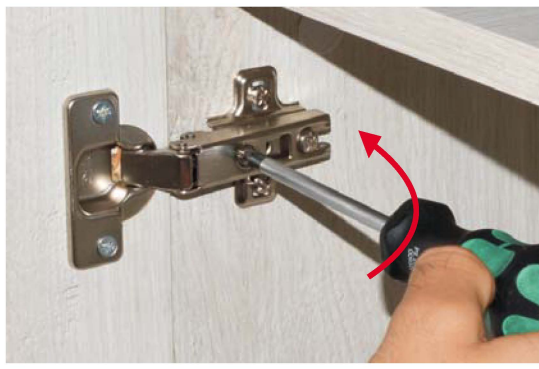

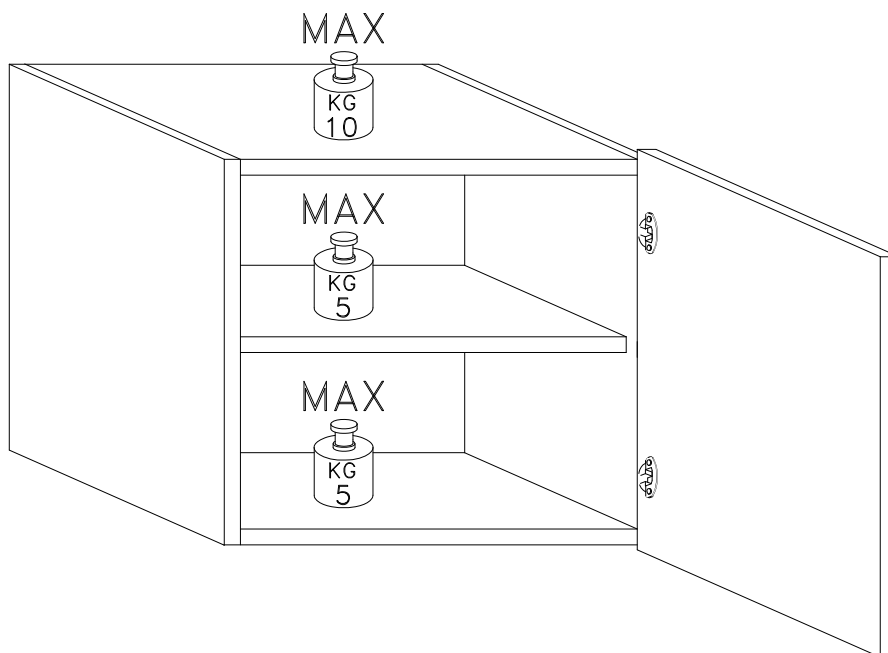
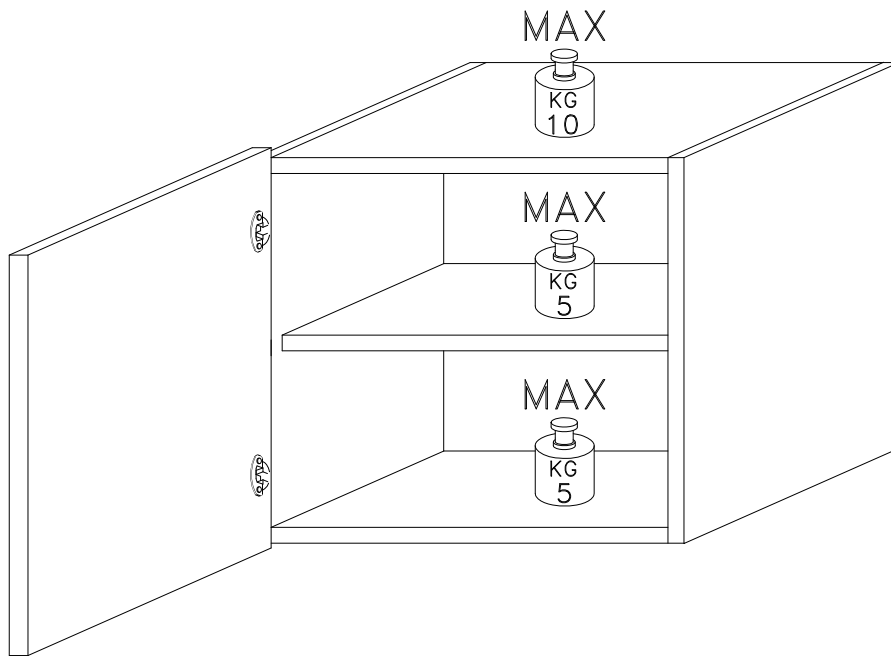

Montageanweisung / Installation instructions / Instruction de montage / Istruzioni di montaggio  
montagehandleiding / Instrukcja montażu / Montaj talimatlar / Osszeselési útmutató / Návod k montáži /  
Návod na montáž / Instrucțiune de montaj / Инструкция по монтажу / Montaj talimatina / Monteringsanvisningar  
Upute za montažu / Instrucciones de Montaje / Navodila za montažo

## INFINITY 2.0

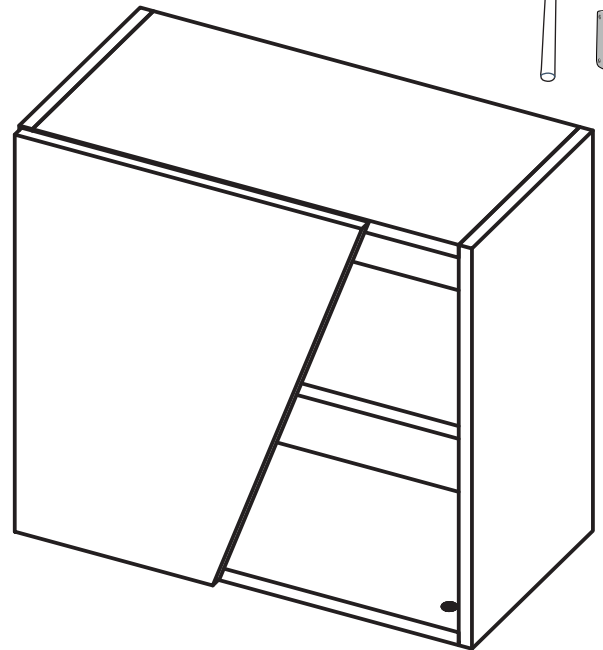
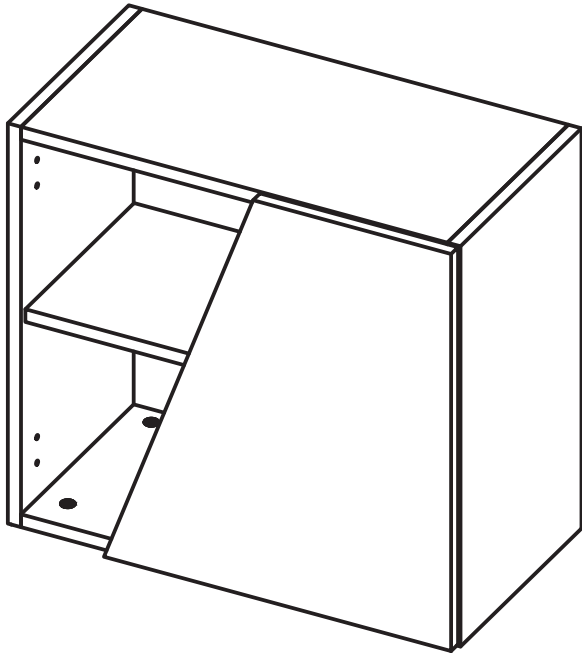
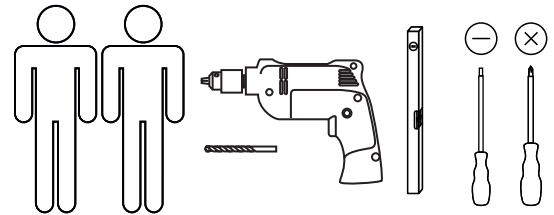
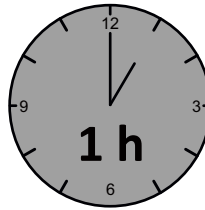

**D** – bitte lesen sie diese montageanleitung gut durch,  
Da wir für fehler, die durch falsche montage entstehen,  
Keine haftung übernehmen!

**Gb** – please read these installation instructions  
Through carefully as we cannot accept any liability  
For faults occurring as a result of incorrect installation!

**Cz** – přečtěte si prosím pozorně tento návod k montáži,  
Aby jste předešli chybám vzniklých špatnou montáží,  
Za které neručíme!

**F** – veuillez lire attentivement cette notice de montage,  
Car nous déclinons toute responsabilité en cas d'erreurs  
Découlant d'un montage erroné !

**I** – prego leggere attentamente le istruzioni per il montaggio,  
Poiché decliniamo qualsiasi responsabilità  
Per difetti derivanti da montaggio errato.

**S** - läs monteringsanvisningarna noggrant.  
Vi avstår oss allt ansvar för defekter som  
Uppstår p.g.a. Felaktig montering.

**Hr** – pažljivo pročitajte upute za montažu,  
Jer otklanjamo svaku odgovornost za pogreške  
Nastale uslijed pogrešne montaže.

**Slo** – prosimo, da pozorno preberete navodila za montažo,  
Saj zavračamo vsakršno odgovornost za napake,  
Ki bi nastale zaradi napačne montaže.

**Nl** – lees u alstublieft deze montagehandleiding goed door,  
Voor fouten door verkeerde montage zijn wij niet verantwoordelijk.

**Pl** – prosze uwaznie zapoznac sie z instrukcja montazu,  
Poniewaz nie ponosimy odpowiedzialnosc za niewlasciwy montaz.

**Hu** – Kérjük, olvassa el figyelmesen  
ezt az összeszerelési útmutatót,  
mert a helytelen összeszerelésből  
a dódó hibákért nem vállalunk felelősséget!

**Sk** – Prosime, dobre prečítajte si tento návod na montáž,  
pretože nepreberáme žiadne ručenie za chyby,  
ktoré vzniknú na základe chybnej montáže!

**Ro** – Vă rugăm să cititi cu atenție aceste instrucțiuni  
de montaj deoarece nu preluăm garanția pentru defecte  
ce apar datorită unui montaj incorect!

**Rus** – Пожалуйста, внимательно ознакомьтесь ù  
с данной инструкцией по монтажу, поскольку мы не  
несем ответственности за ошибки, причиной которых  
является неправильный монтаж.

**Tu** – İlkonce kullanma klavuzunu iyi okuyun,  
yalnis montaj yapasaniz bunun sorumlusu biz degiliz.

**Es** – Se ruega leer con atención las instrucciones  
de montaje debido a que declinamos cualquier  
responsabilidad  
por defectos derivados de un montaje erróneo.

**SERVICEKARTE**

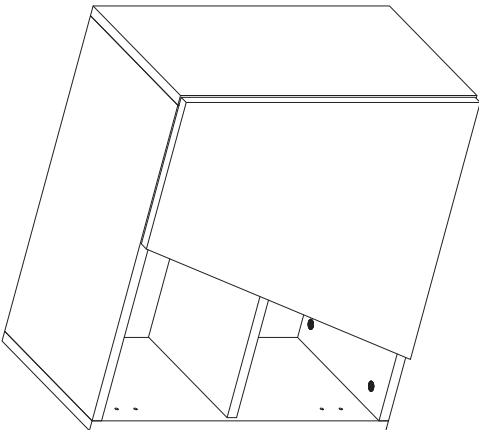
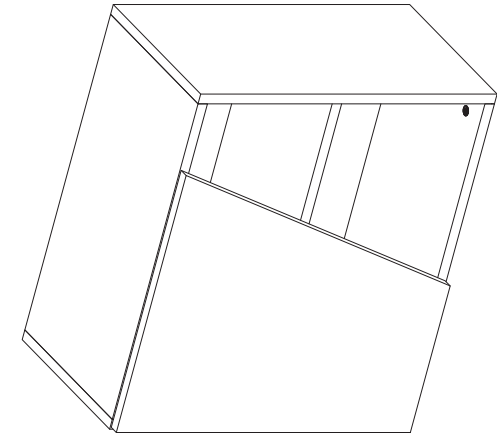
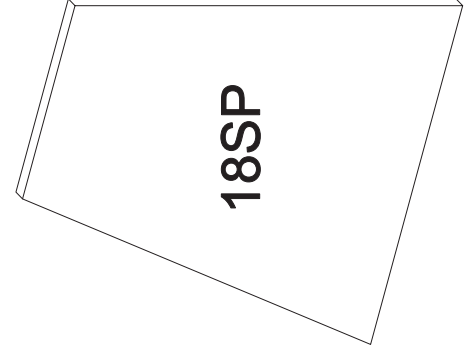
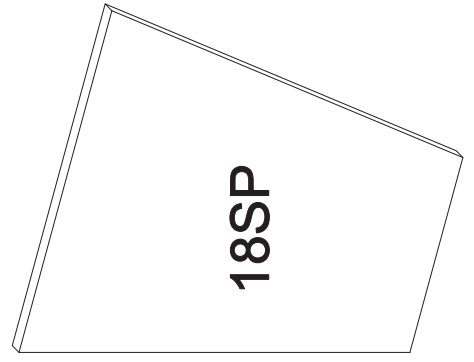
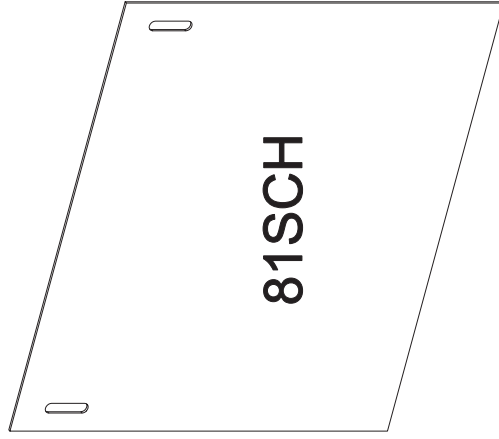
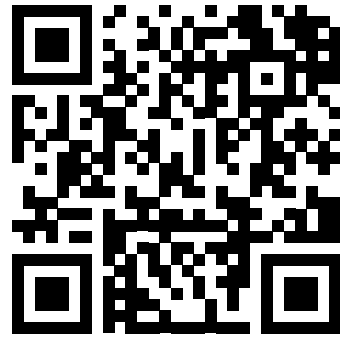
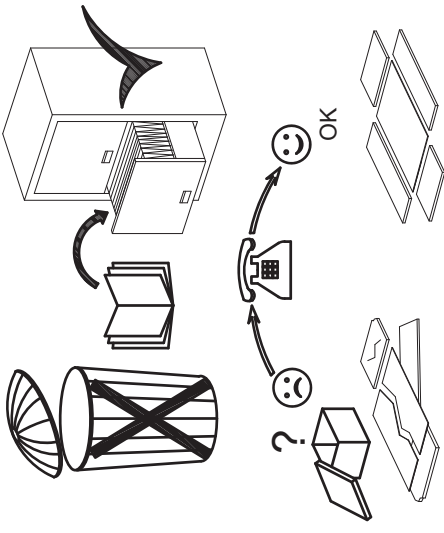

**81FI**



**81TO**



**81PI**

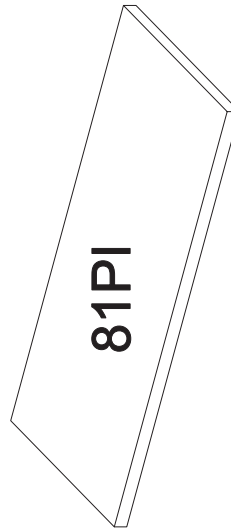

**81TO**

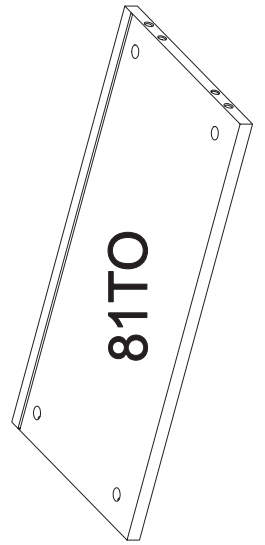

**81FI**

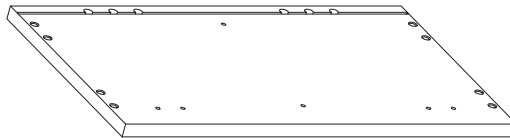

**ONDERDELEN LYST-SERVICEKARTE-FORMULAIRE DEMANDES SAV-SPAREPARTS LIST-SCHEDADI SERVIZIO**

BESLAG-BESCHLAEGE - QUINCALLERIE - HARDWARE - FERRAMENTA

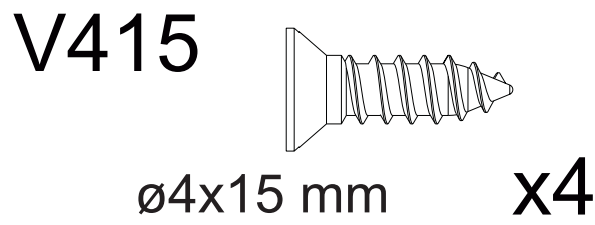
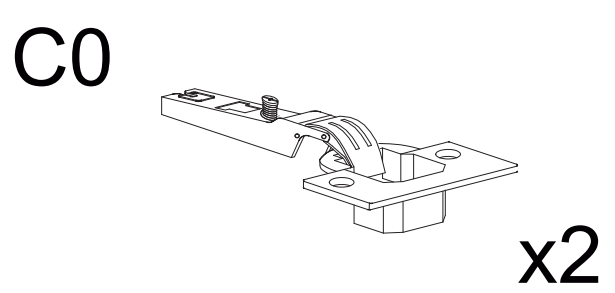
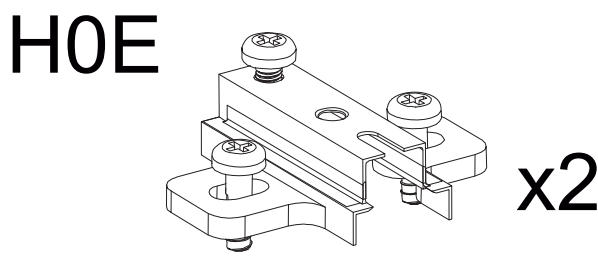
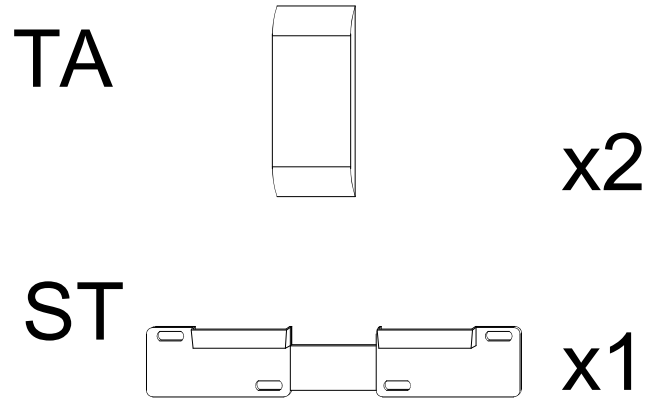
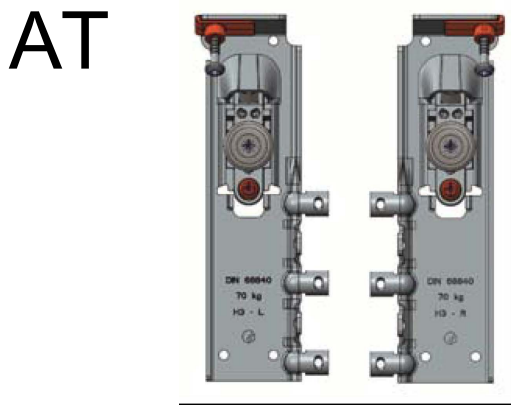
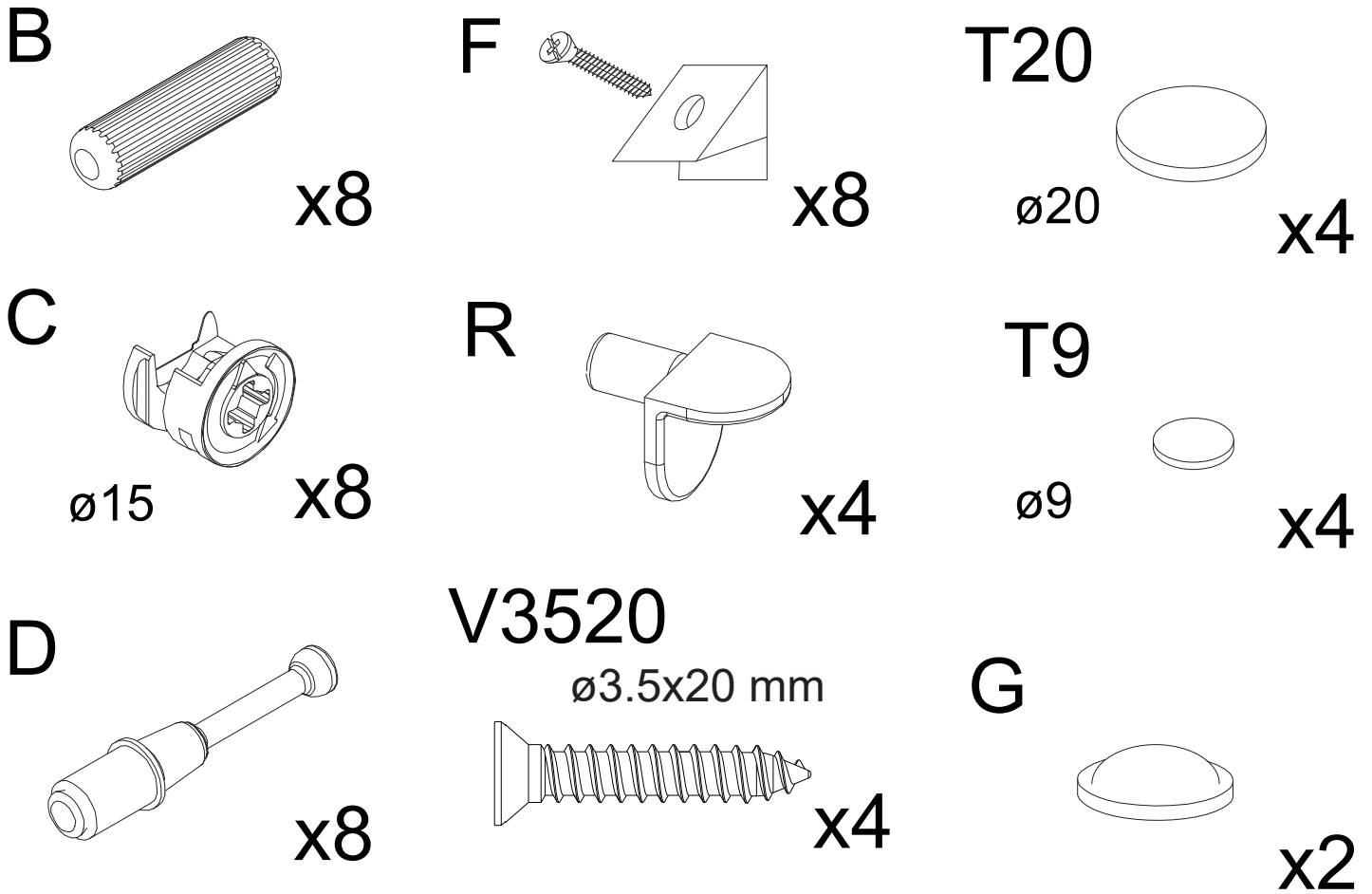



1

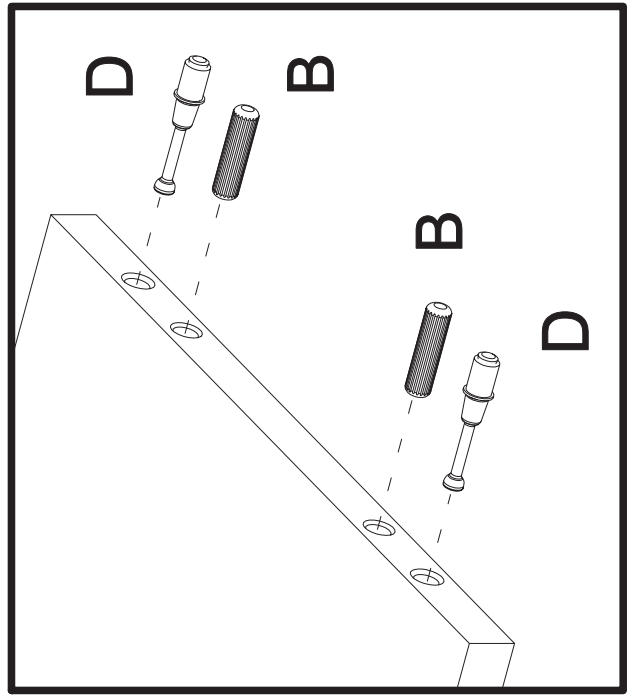
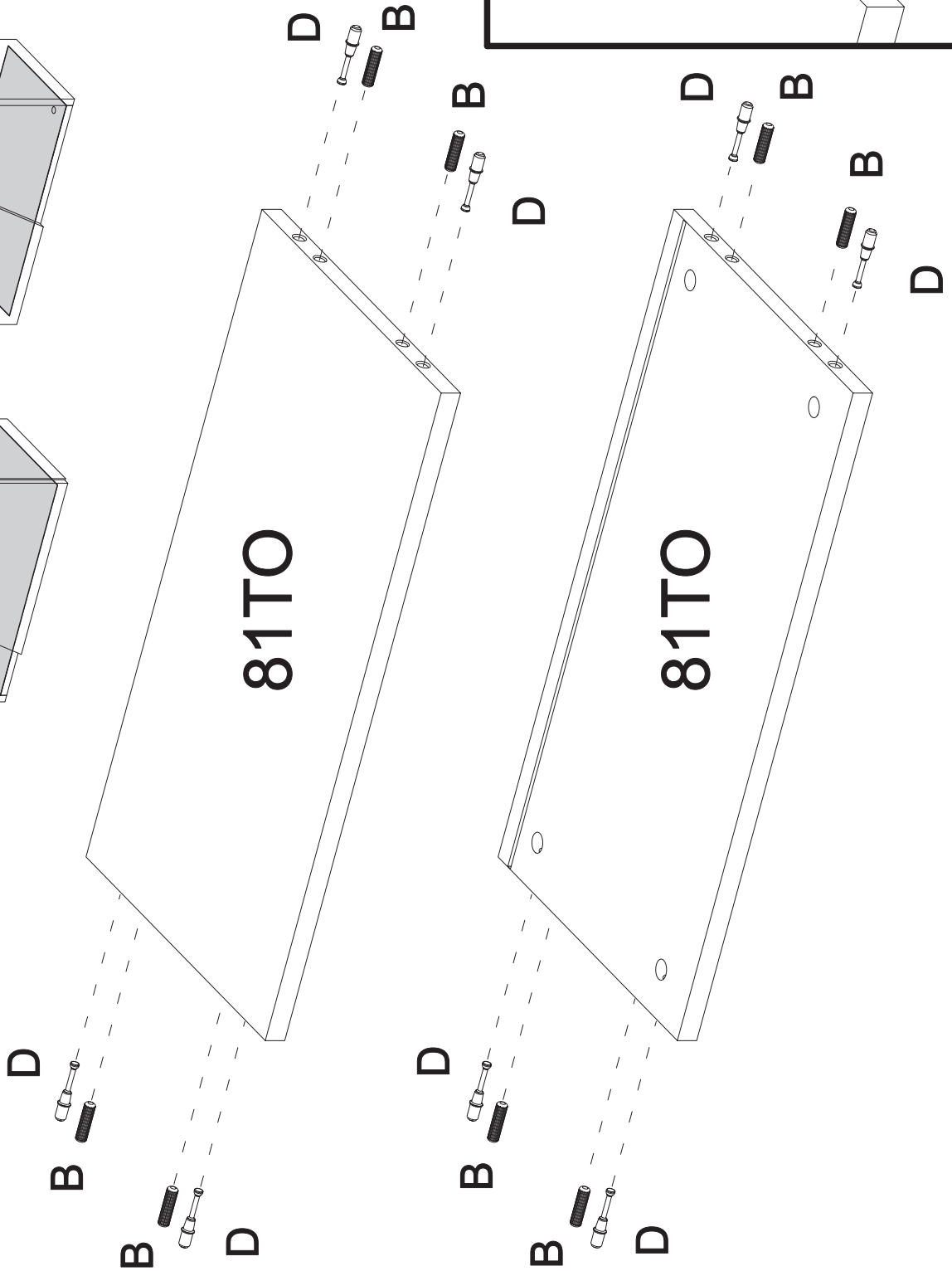
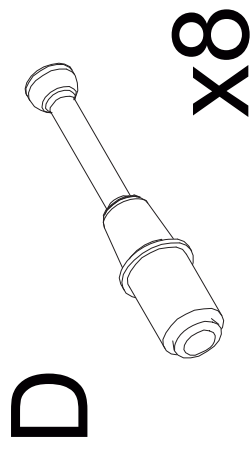
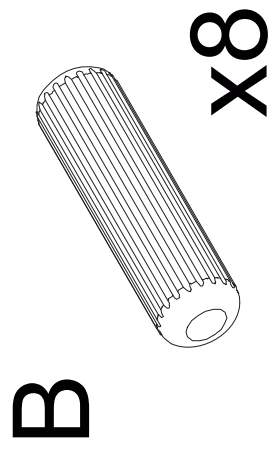
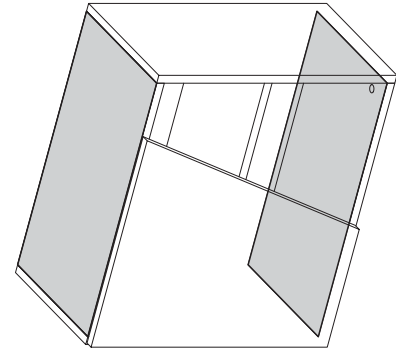
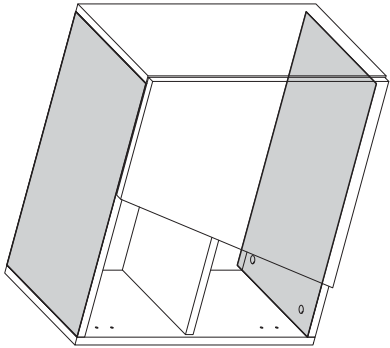

2

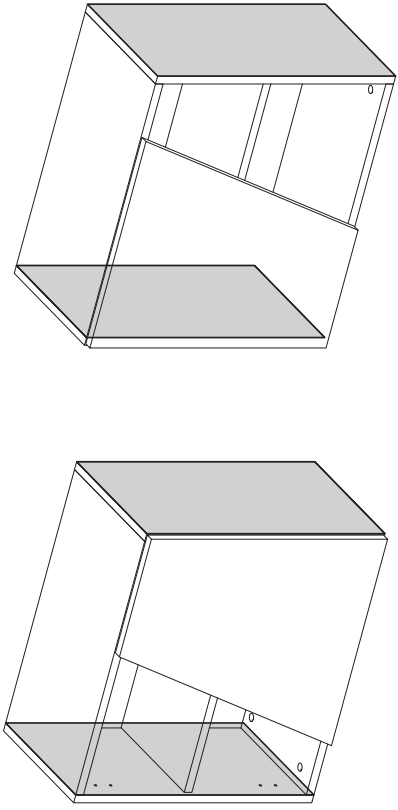

R

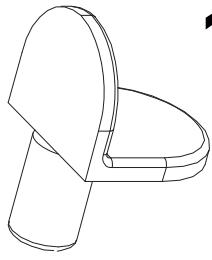

x4

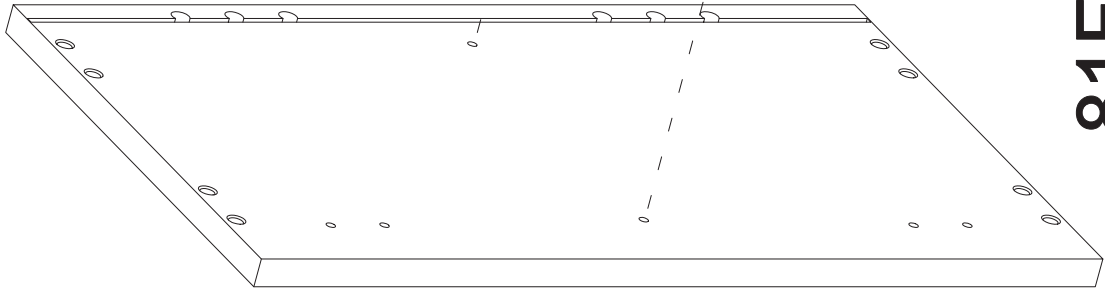
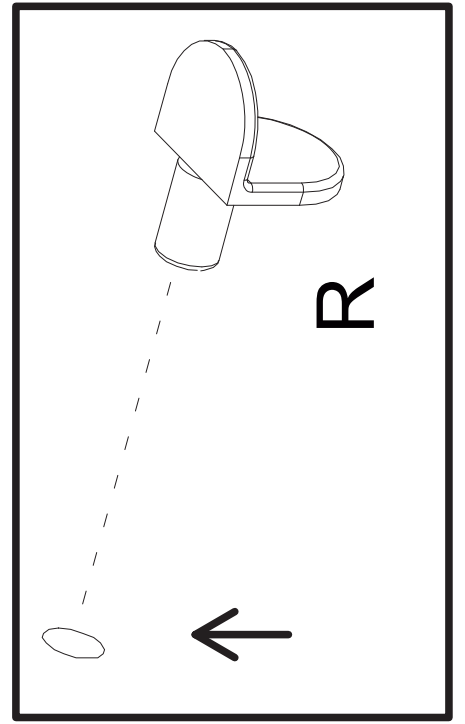
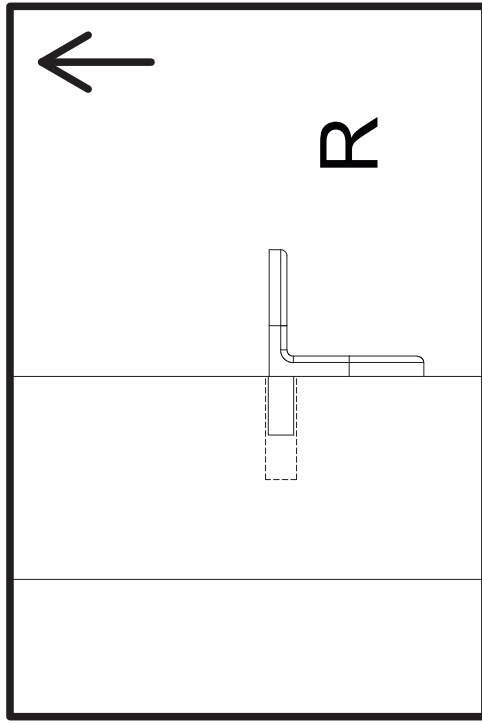

R

R

R

R

81FI

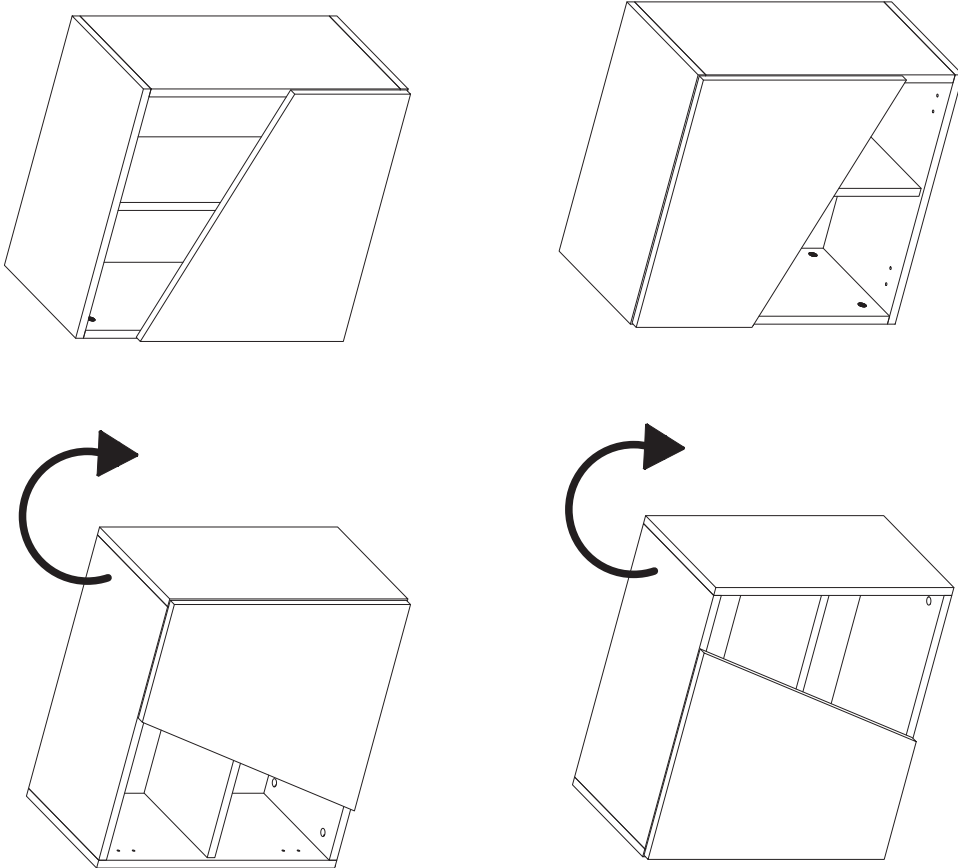
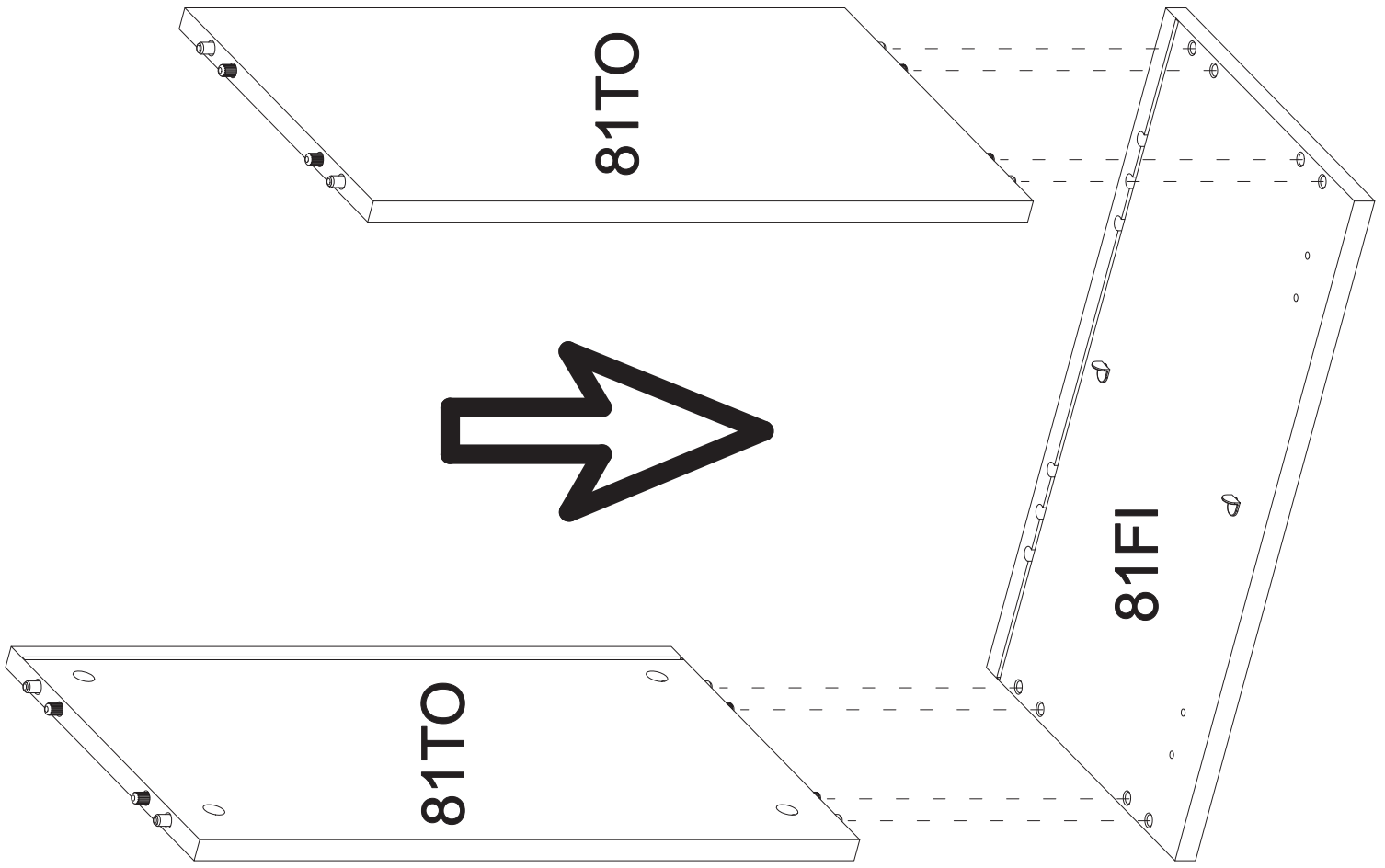

3

4

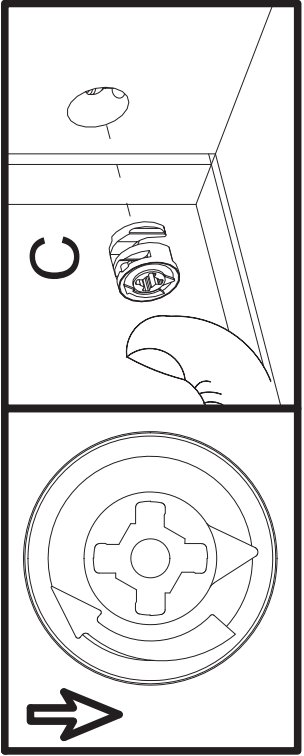
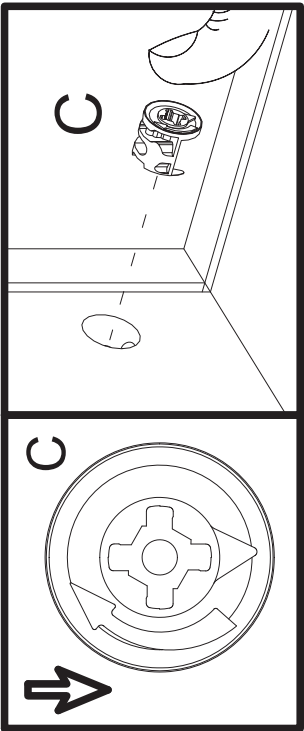

ø15 x4

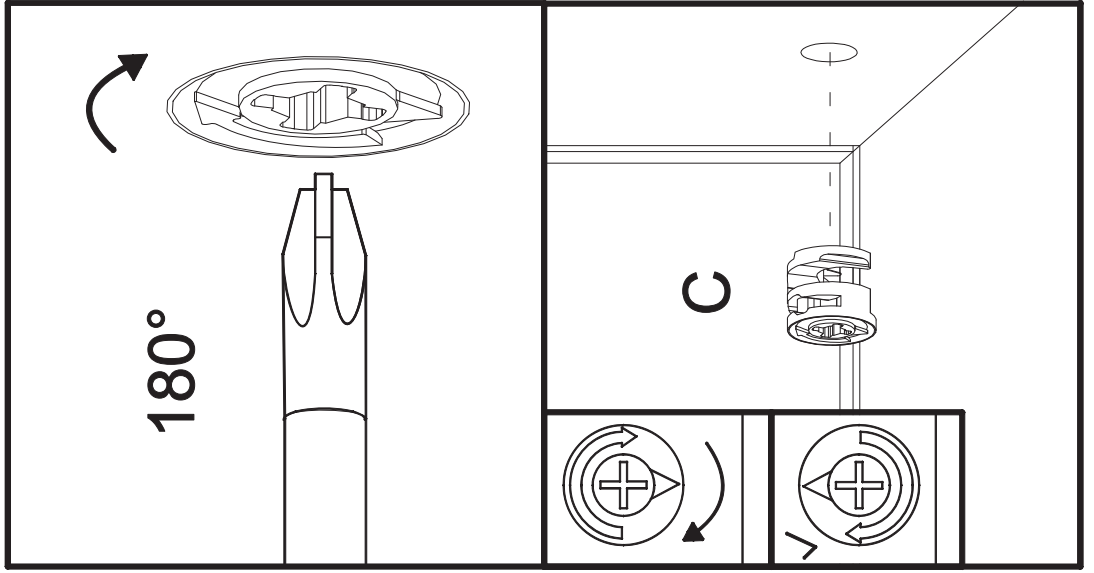
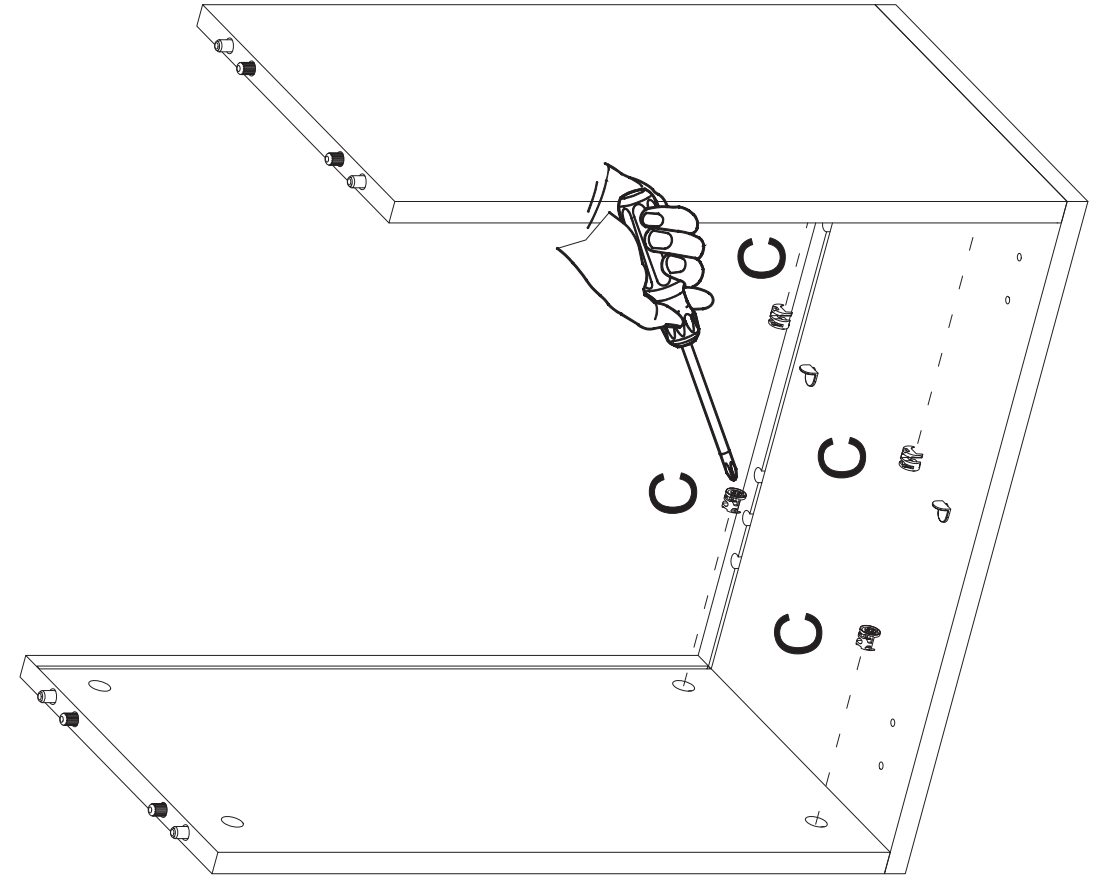
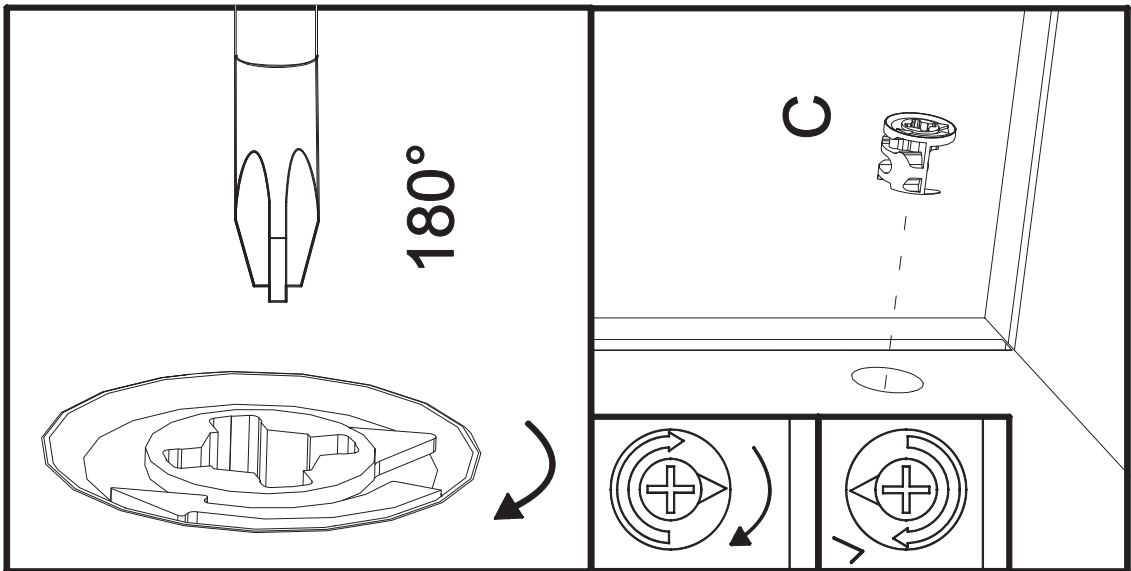
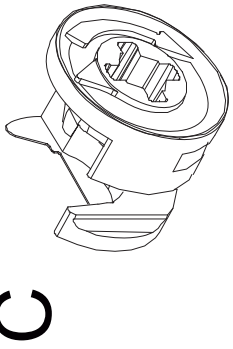

5

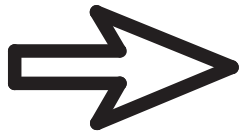
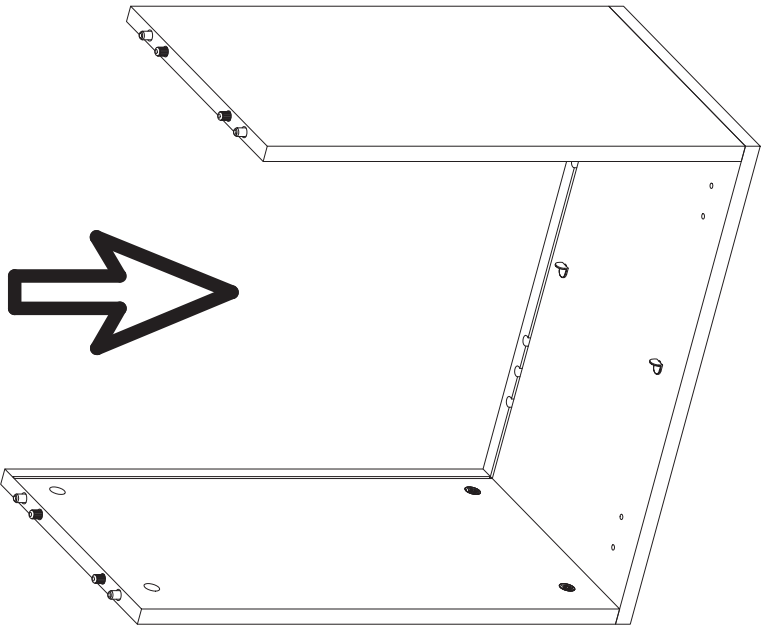
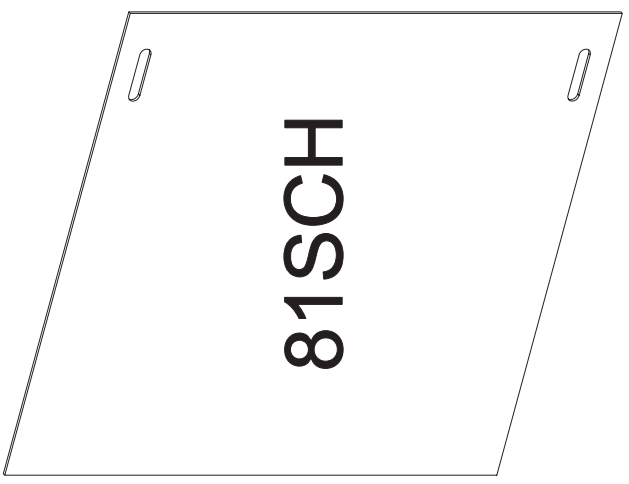

6

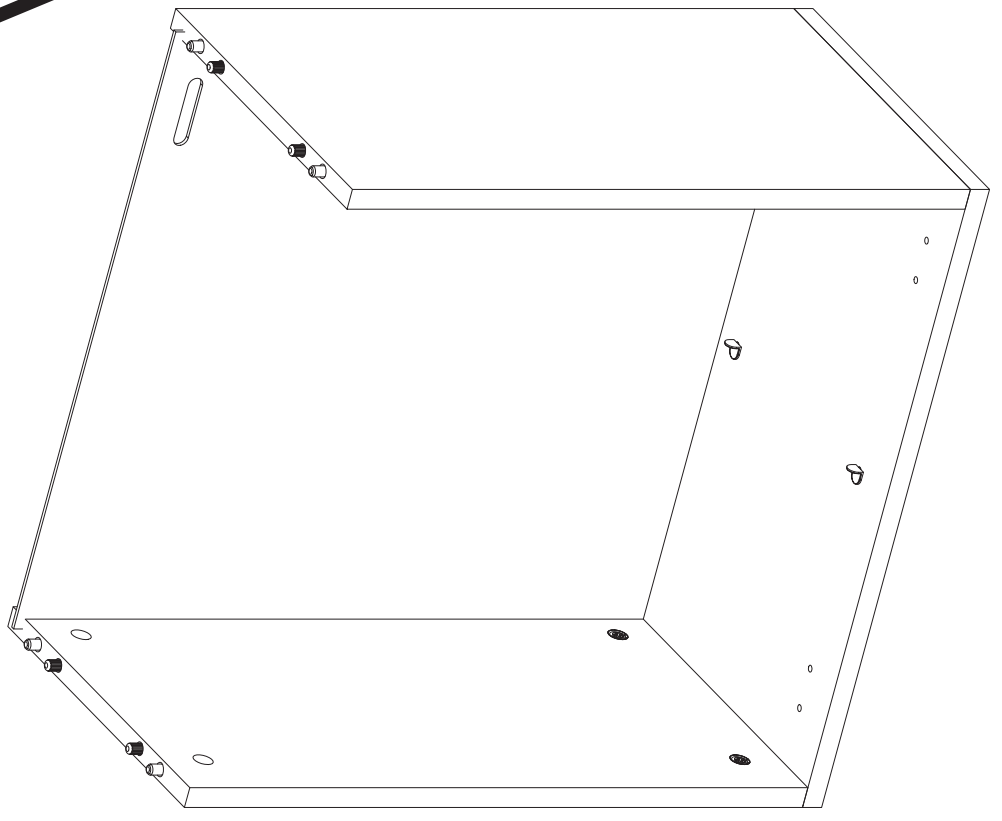
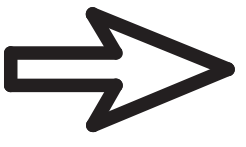
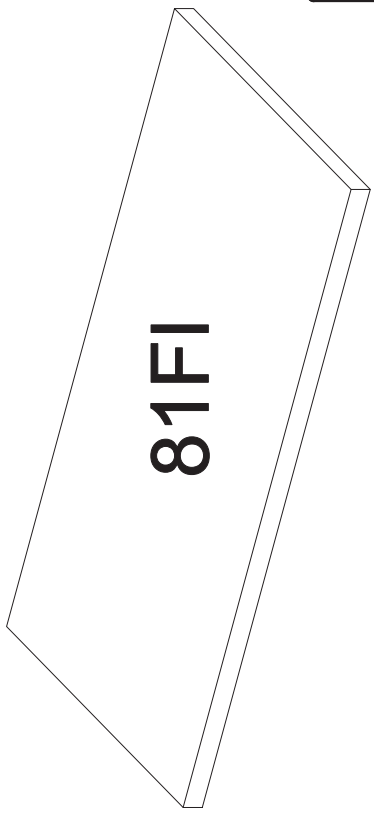

7

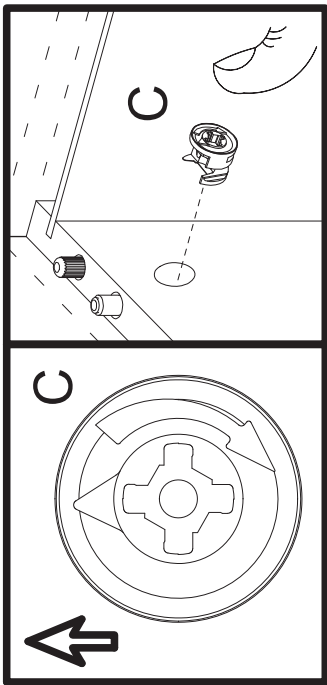

C

ø15

x4

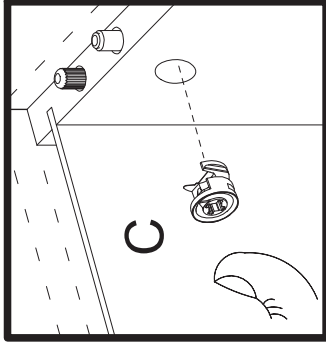
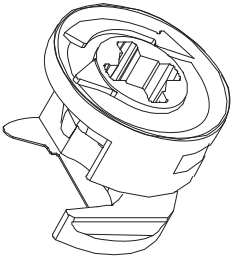

C

C

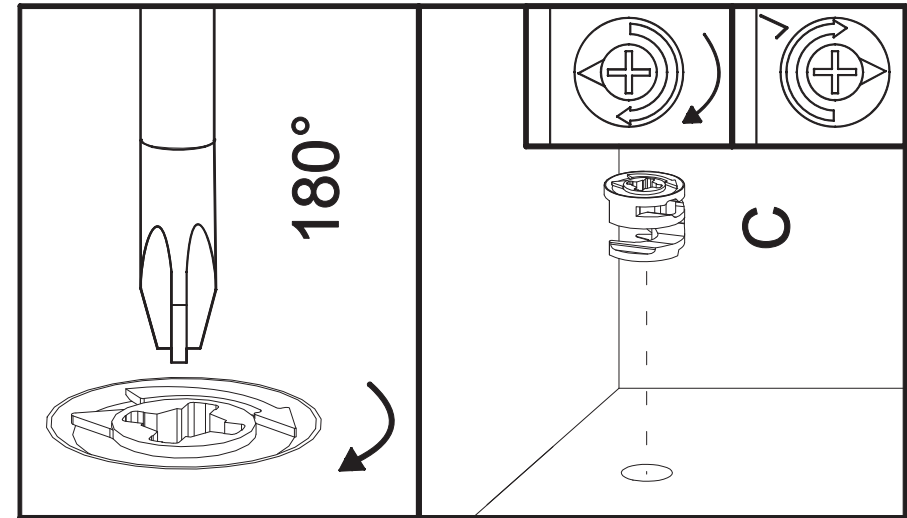

C

180°

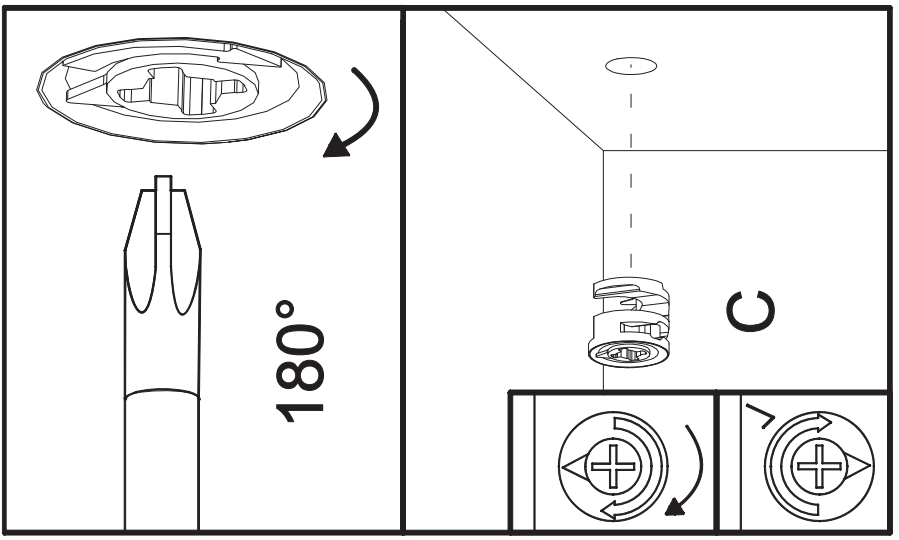
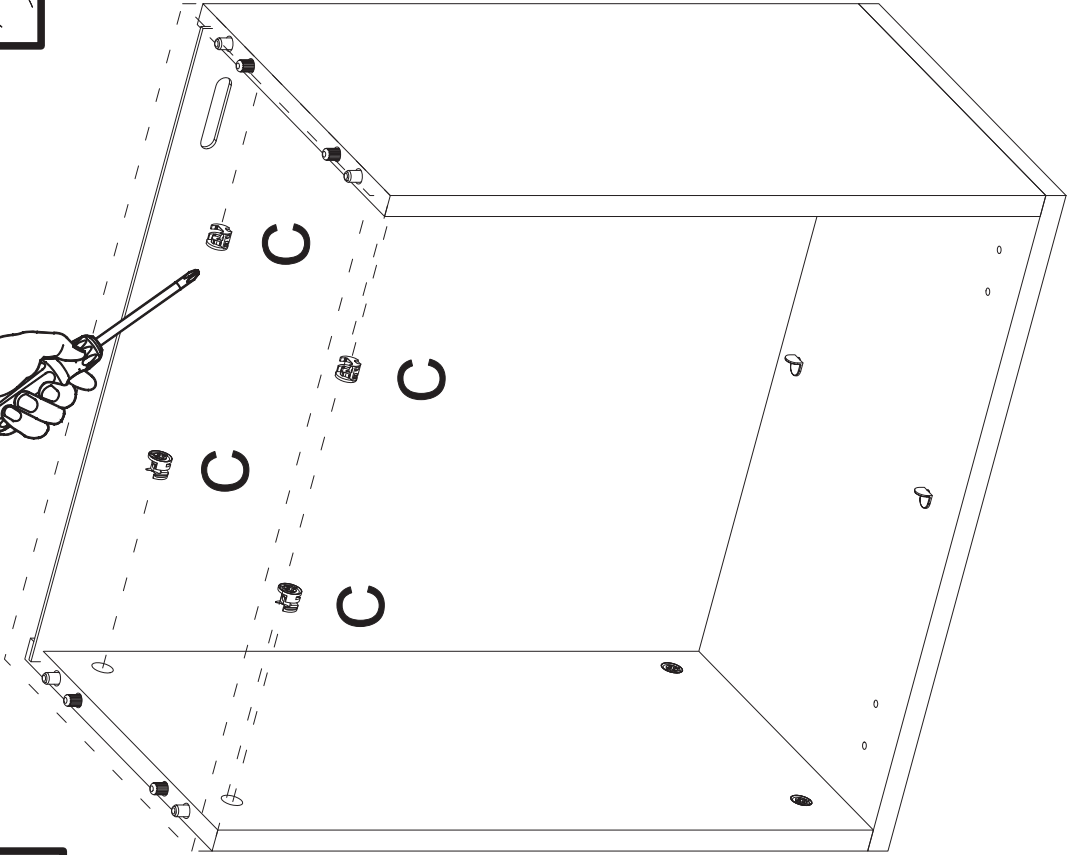
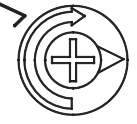
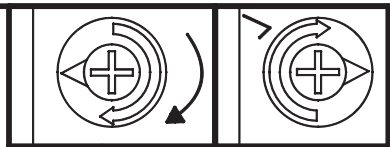
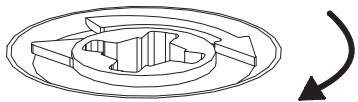

C

180°

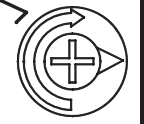
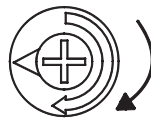
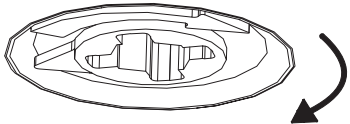

8

F

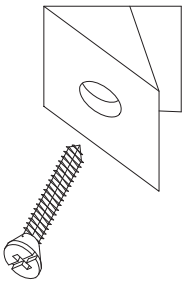

X8

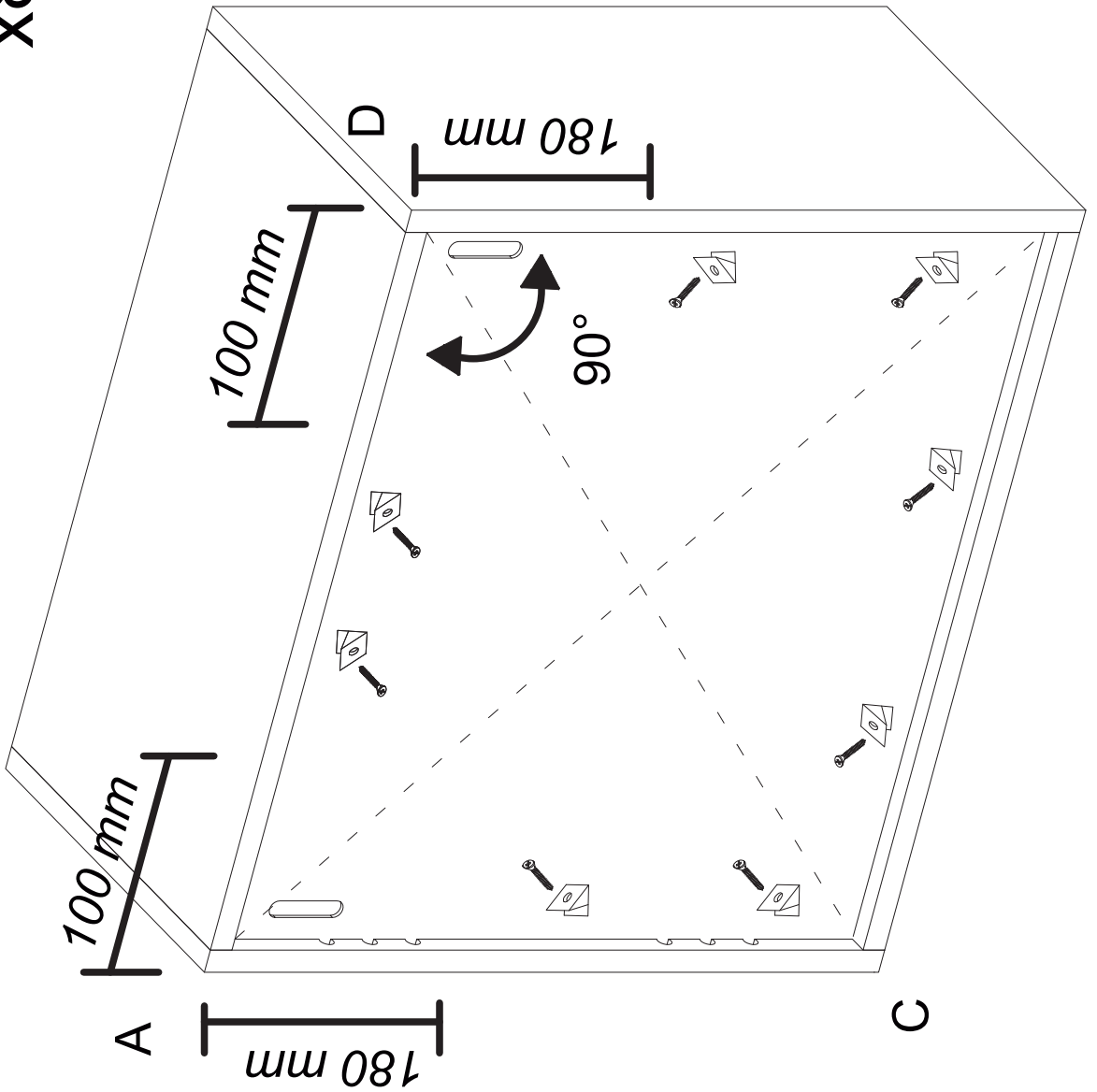

G

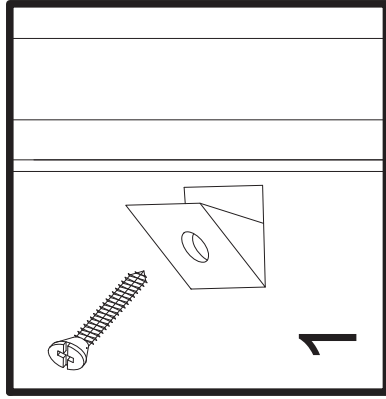
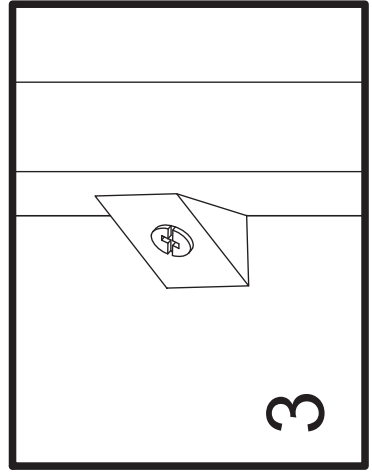
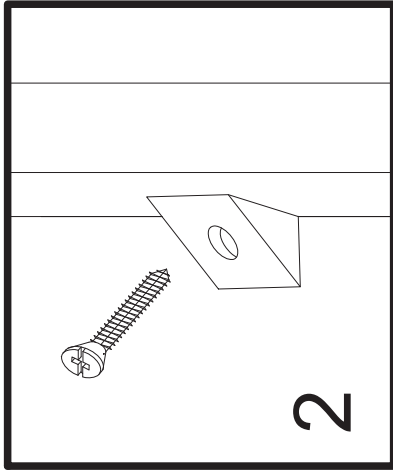
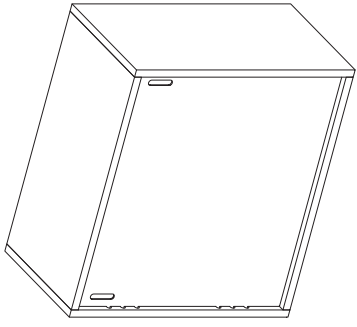
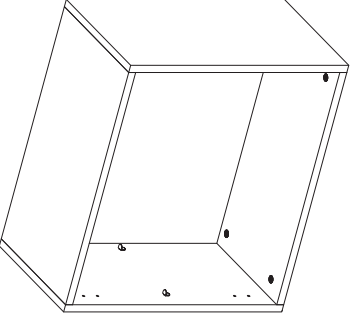

B

C

D

9

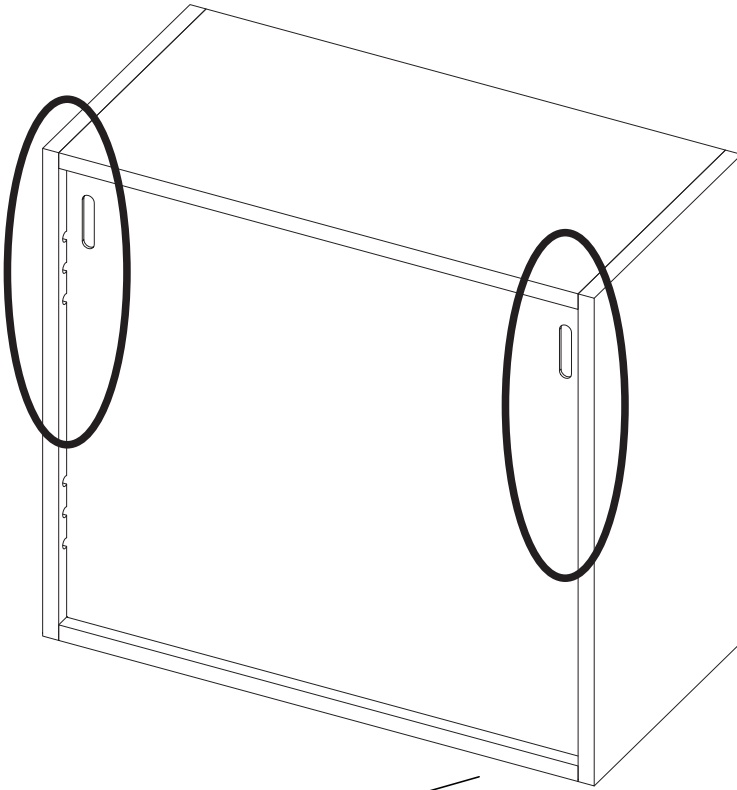

AT

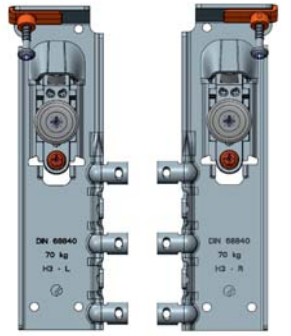

L3520

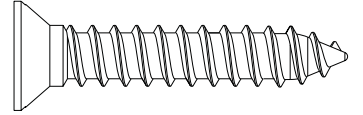

ø3.5x20mm x4

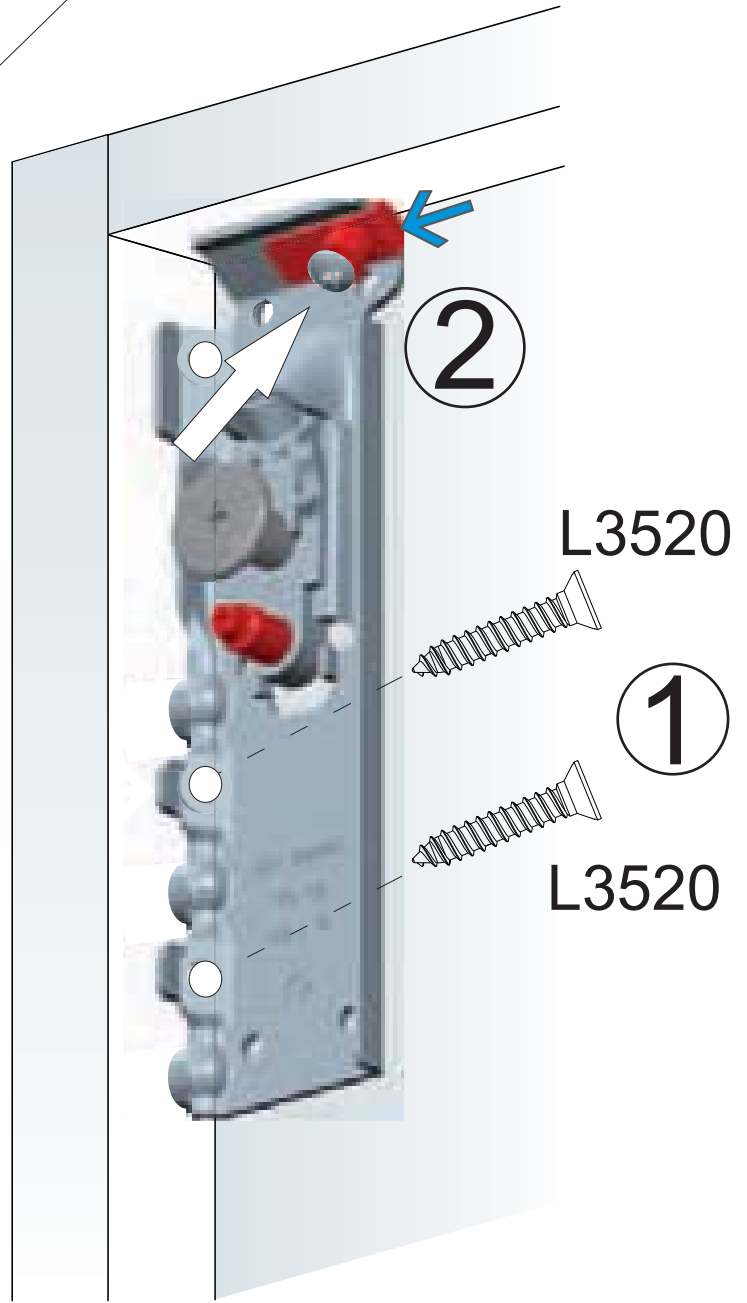
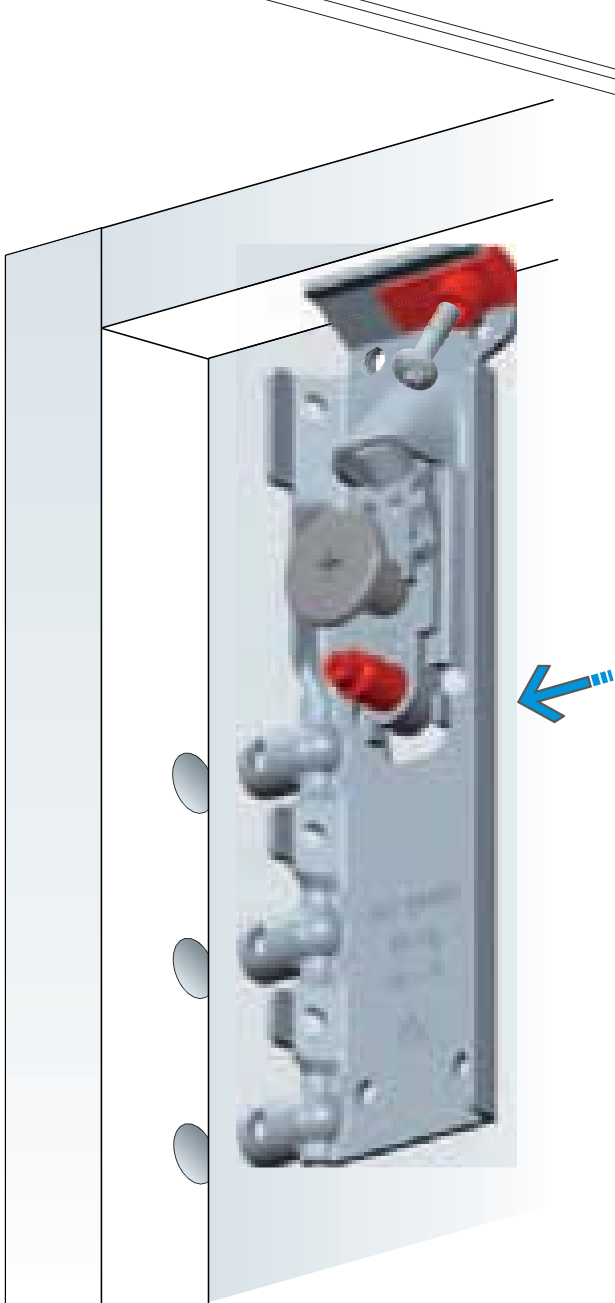



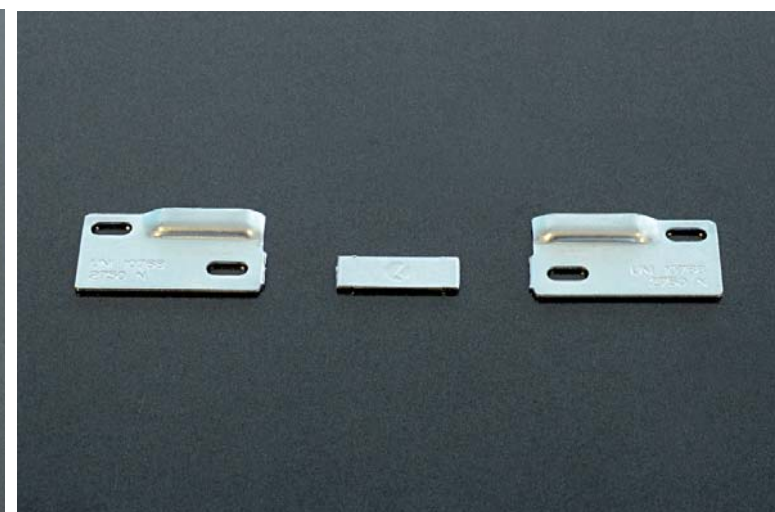
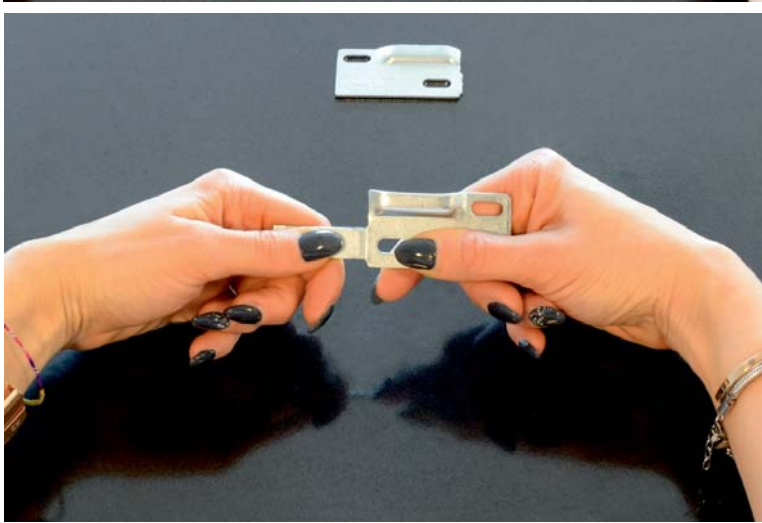
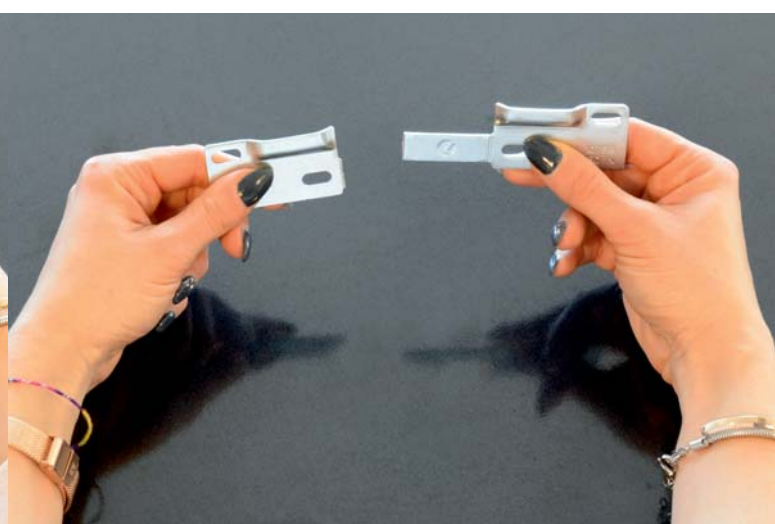
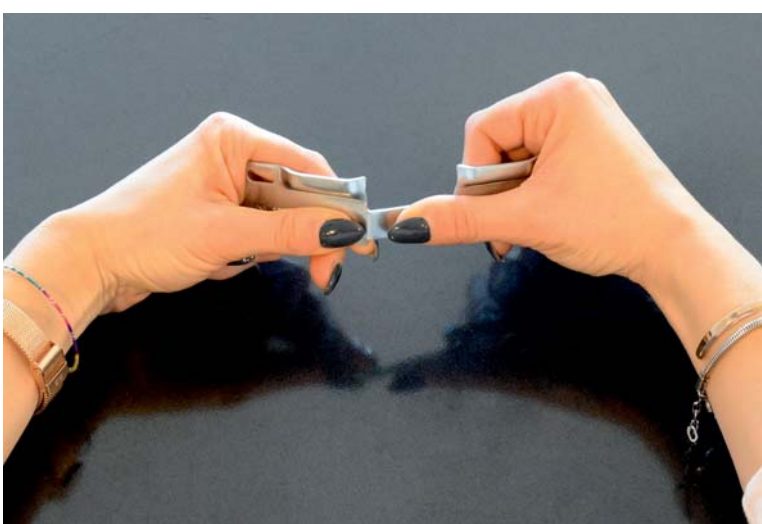
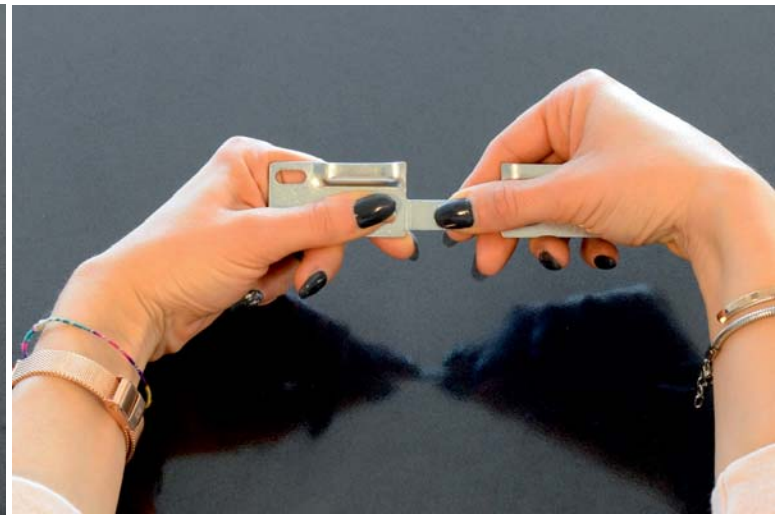
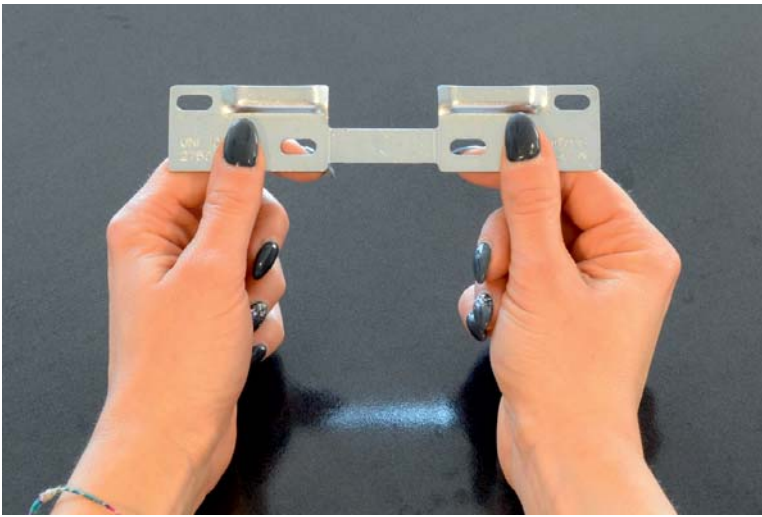



ST

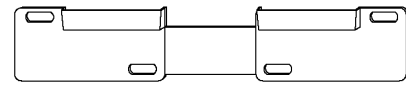

x1

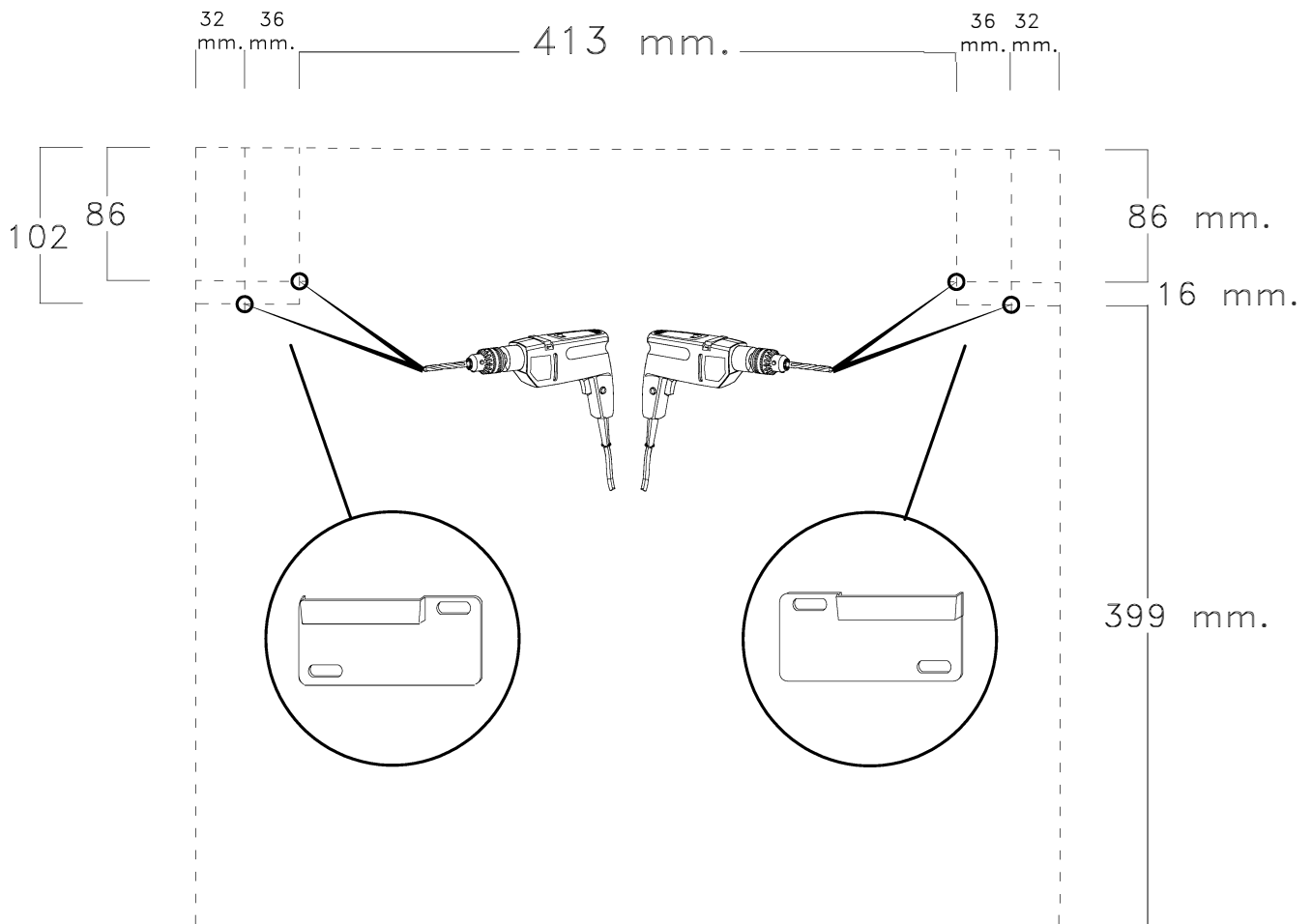

Gentile Cliente

Il montaggio dei pensili deve essere effettuato da personale competente. I tasselli di fissaggio non sono compresi nella ferramenta. Scegliere il tipo di tassello per il fissaggio più adatto alla tipologia di muro. Assicurarsi l'idoneità della parete per un sostegno sicuro del pensile.

Dear Customer,

The assembling of the hanging elements must be done by a competent staff. The wall plugs are not included in the hardware package. Choose the wall plugs more suitable to the type of the wall. Ensure the suitability of the wall for a secure support of the hanging element.

Sehr geehrter Kunde, die Montage der Hängeelemente muss von Fachpersonal ausgeführt werden!

Bitte verwenden Sie eigene Dübel, die der Beschaffenheit der Wand entsprechen. Zu Ihrer eigenen Sicherheit legen wir dem Beschlagbeutel keine Dübel bei.

Cher client, les éléments muraux ne peuvent être installés que par du personnel qualifié ! Veuillez utiliser vos propres ancrages adaptés à la nature du mur. Pour votre sécurité, nous n'incluons pas de chevilles dans le matériel.

Estimado cliente, el montaje de los muebles colgados en la pared debe ser realizado por personal competente. Los tacos de fijación no están incluidos en la bolsa de herrajes. Elija el tipo de anclaje de fijación que mejor se adapte al tipo de pared. Asegúrese de que la pared sea adecuada para un soporte seguro del mueble colgado en la pared.

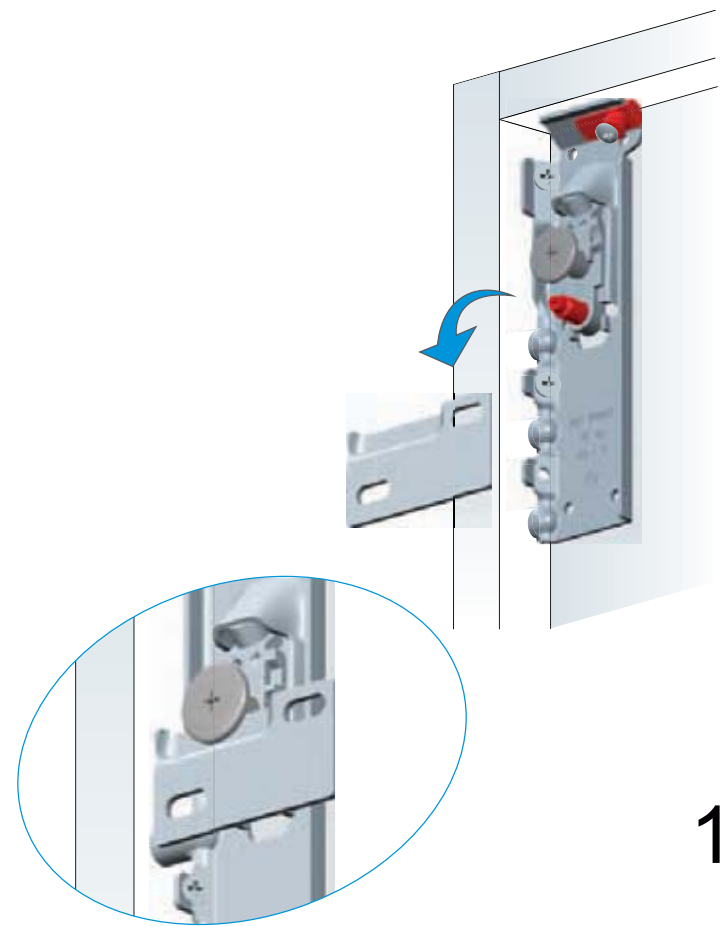

1

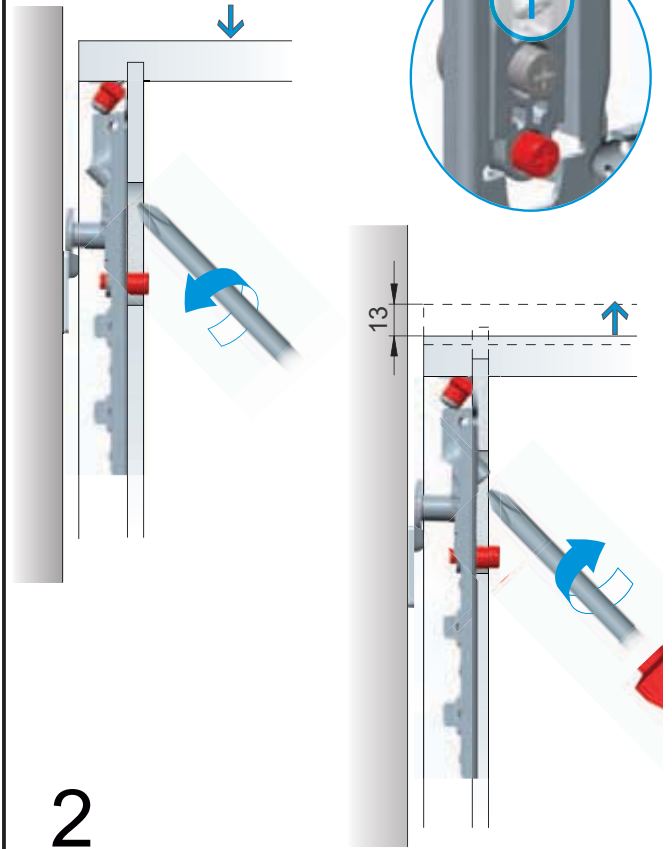

2

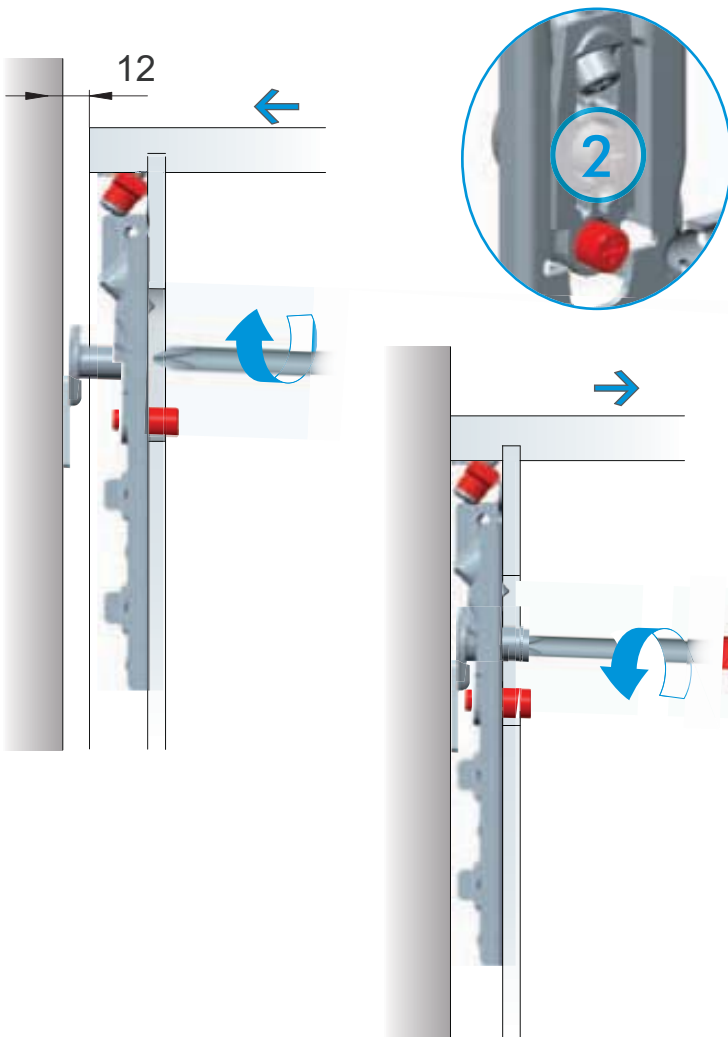

3

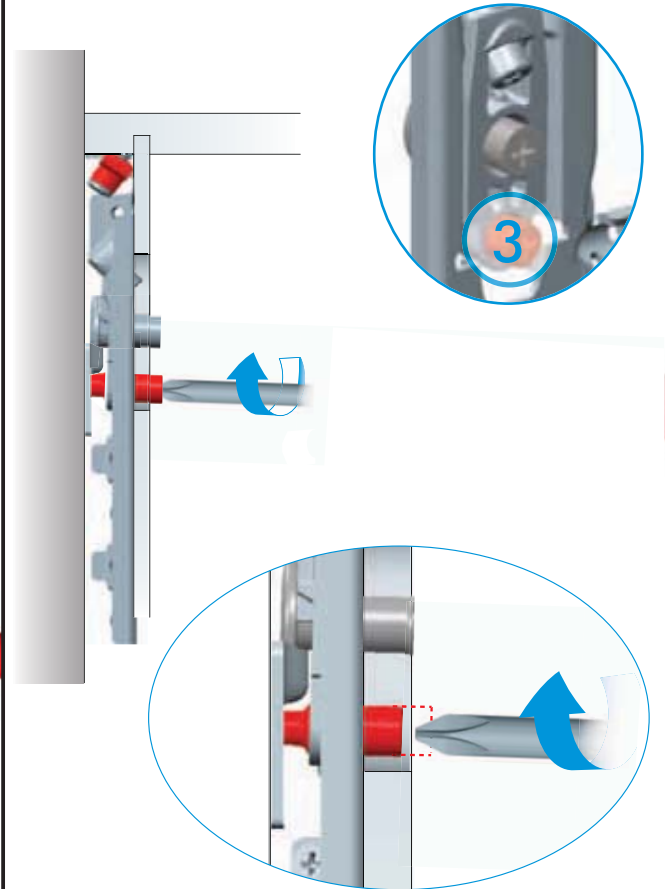

4

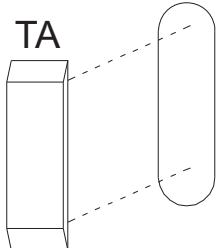

10

V415  
x2

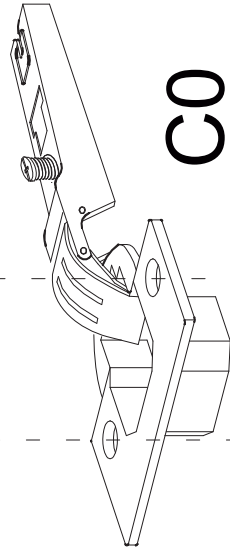
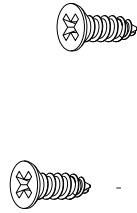

C0

P

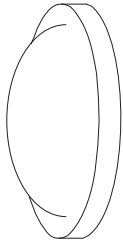

x2

x2

C0

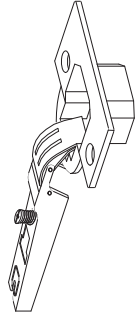

V415

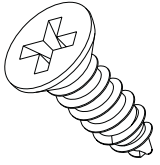

ø4x15 mm x4

V415 x2

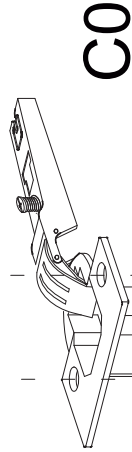

C0

V415 x2

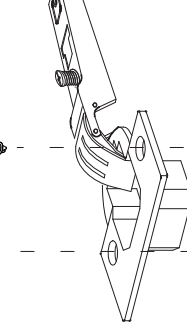
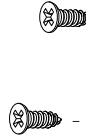

C0

18SP

P

P



P



11

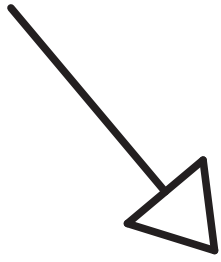

11a

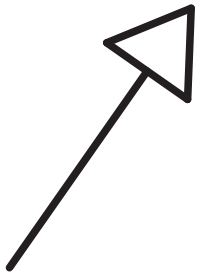

11b

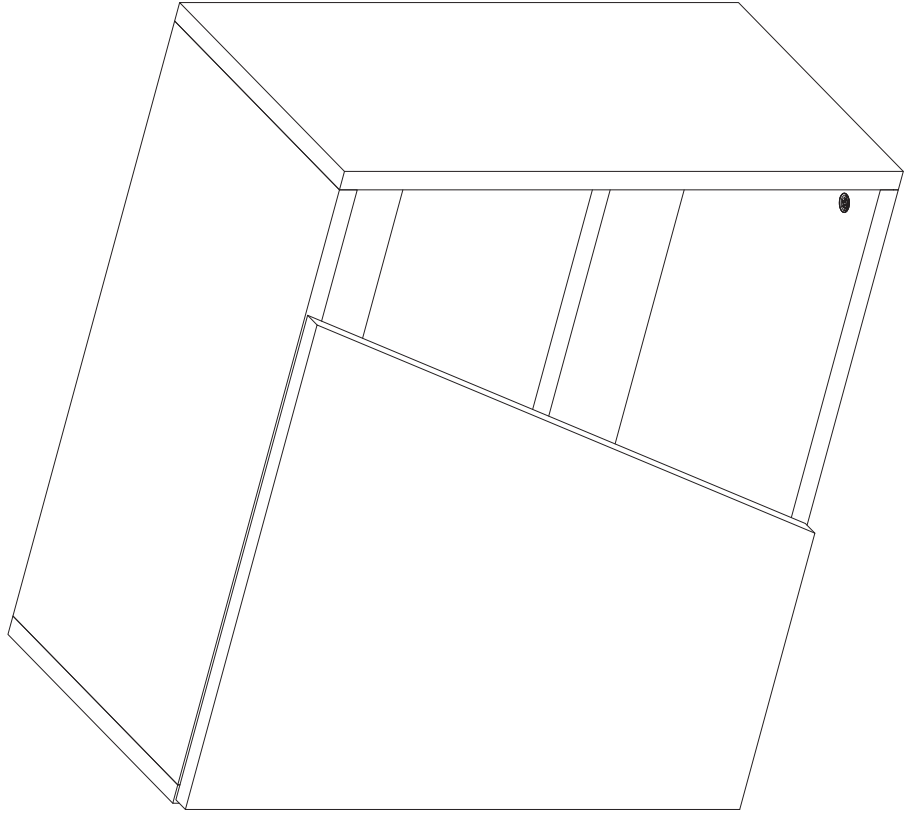
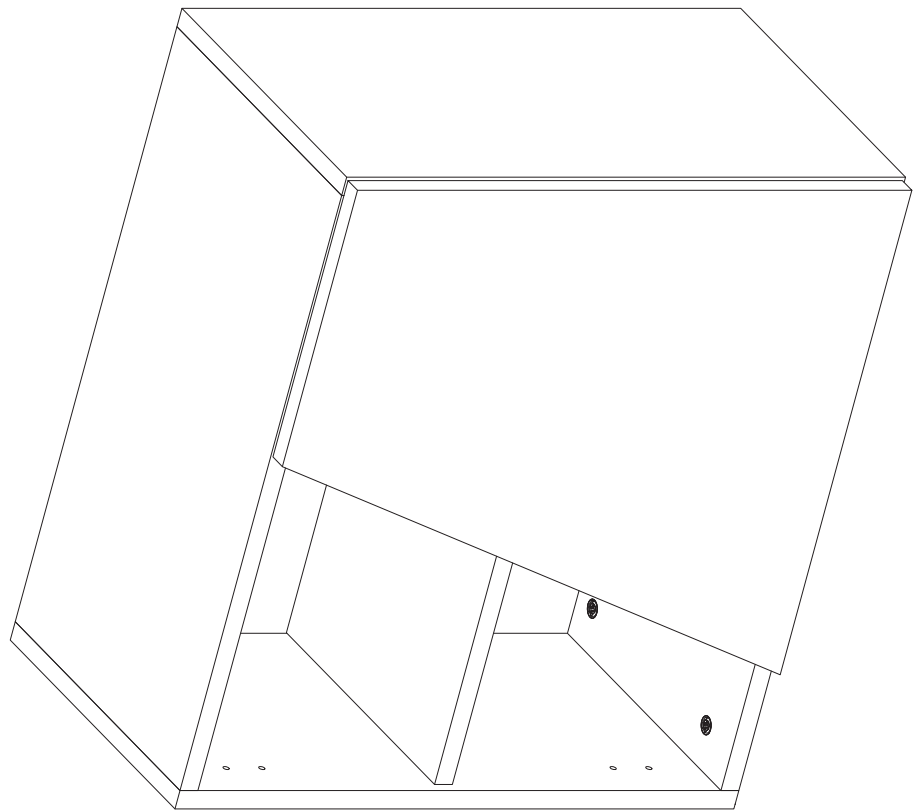

11a

H0E

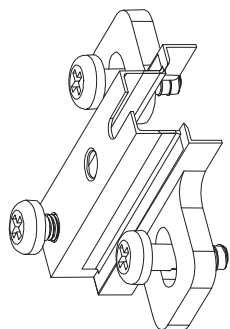

x2

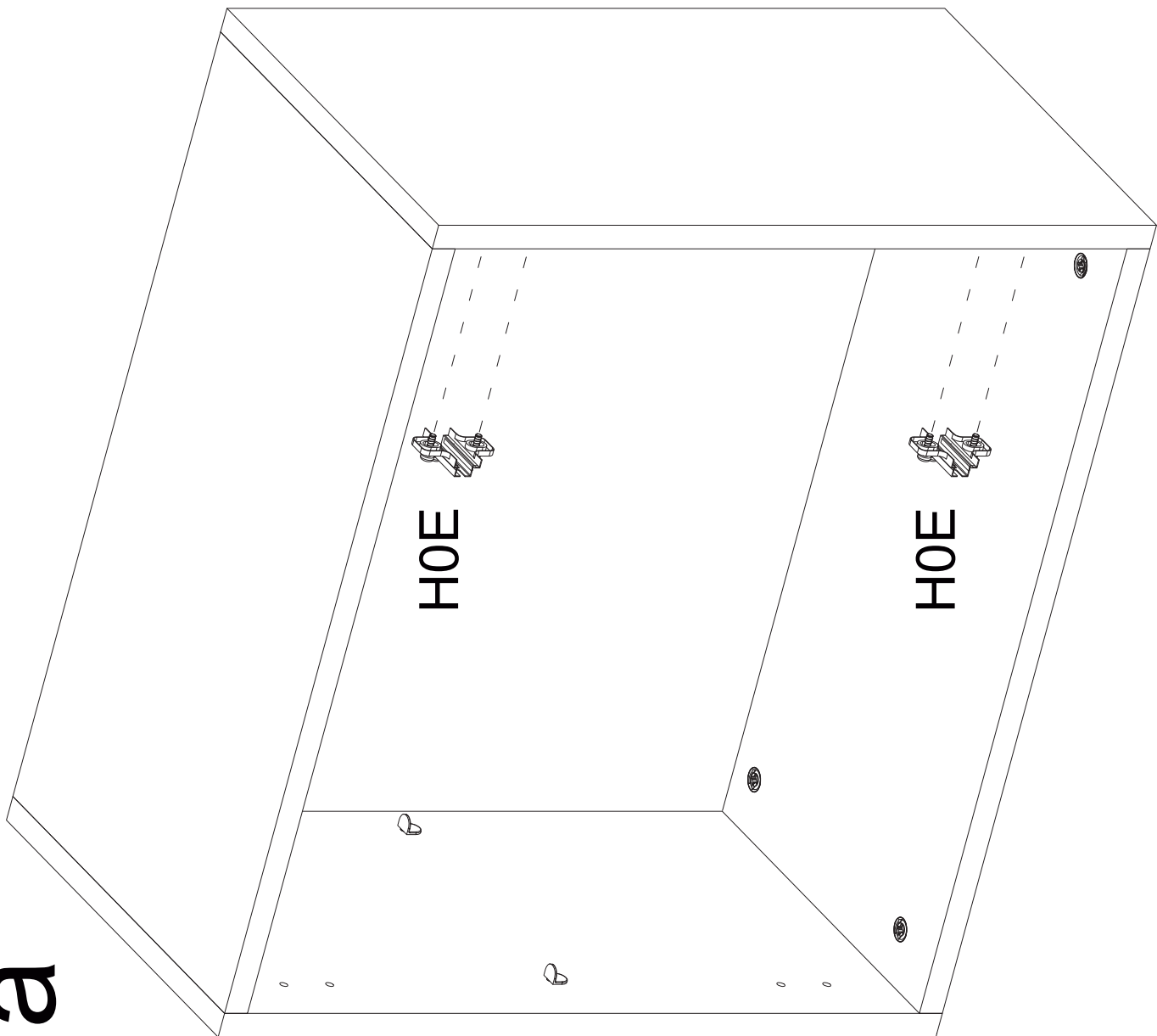
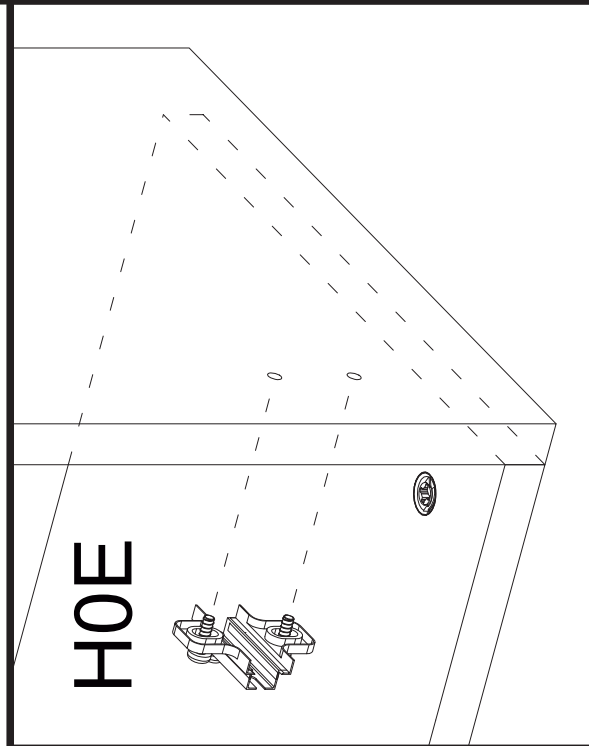
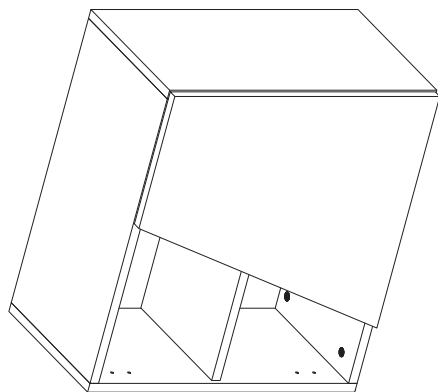



11b

HOE

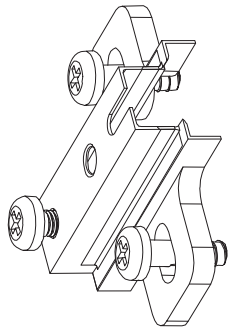

x2

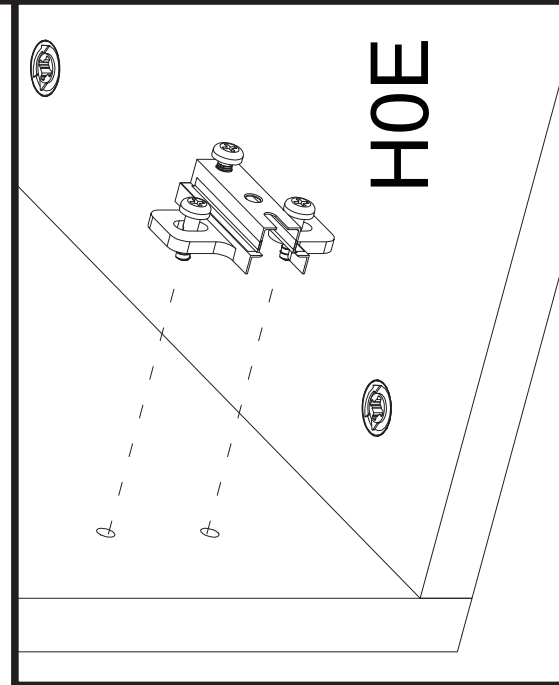
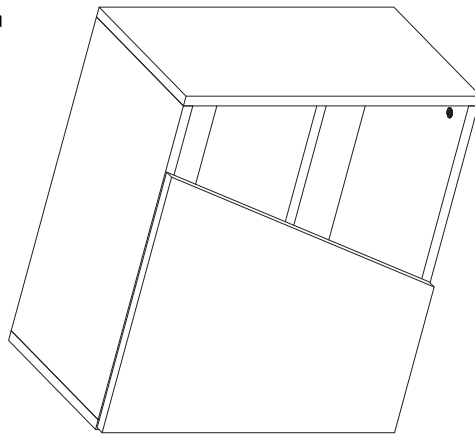

HOE

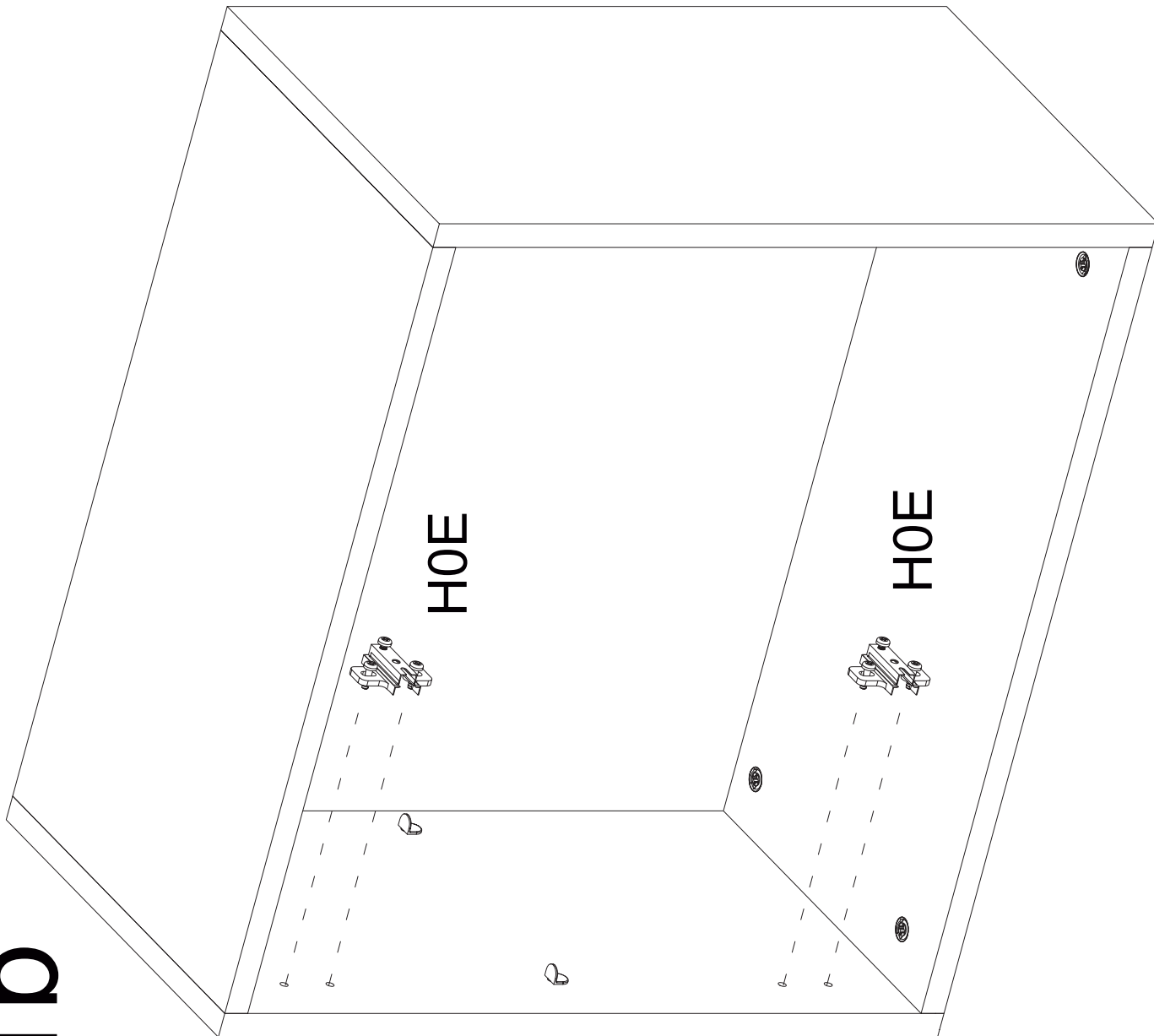

HOE

HOE

# 12a

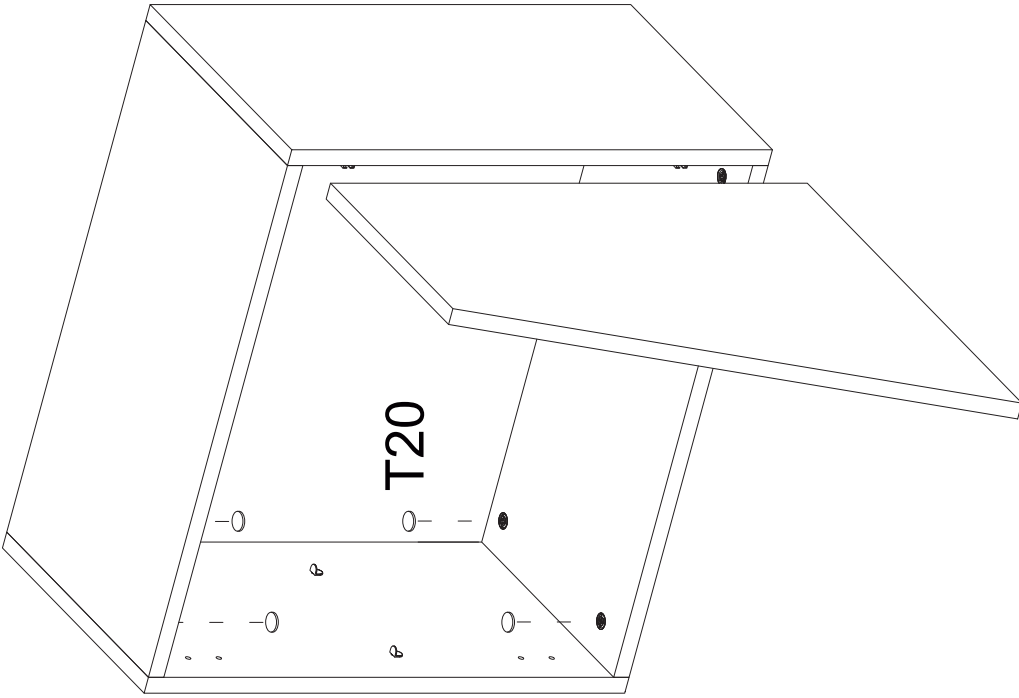

# 12b

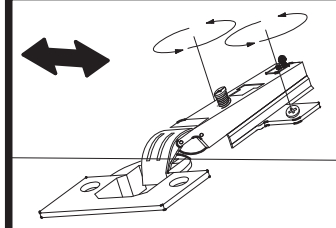
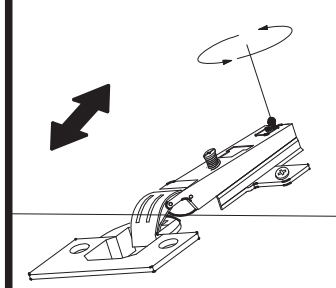
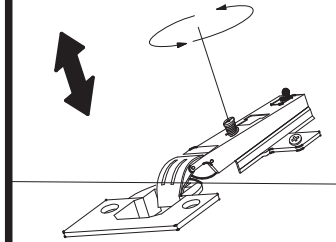
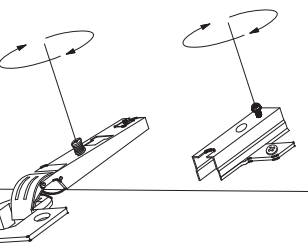
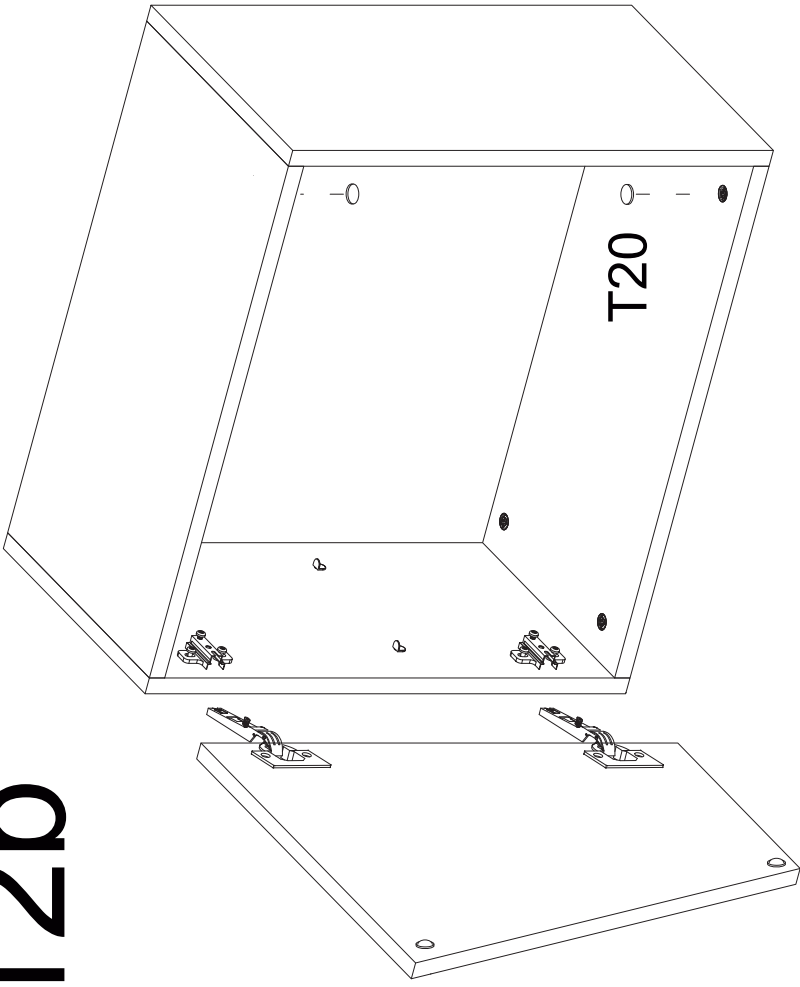

# T20

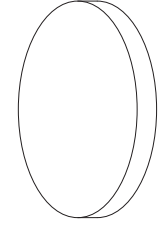

# ø20

# X4

# T20

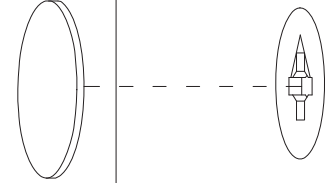

# C



13a

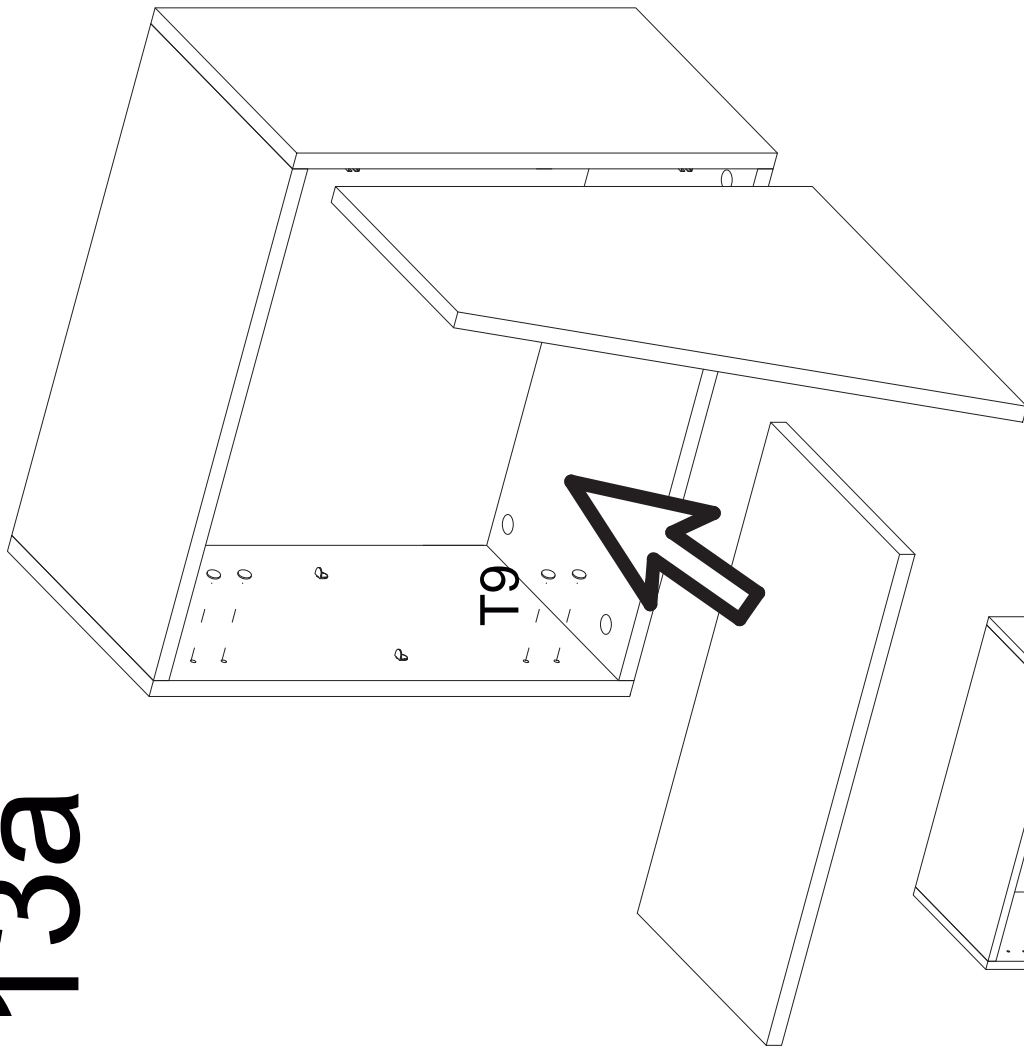

T9

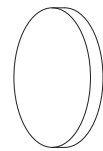

ø9

X4

13b

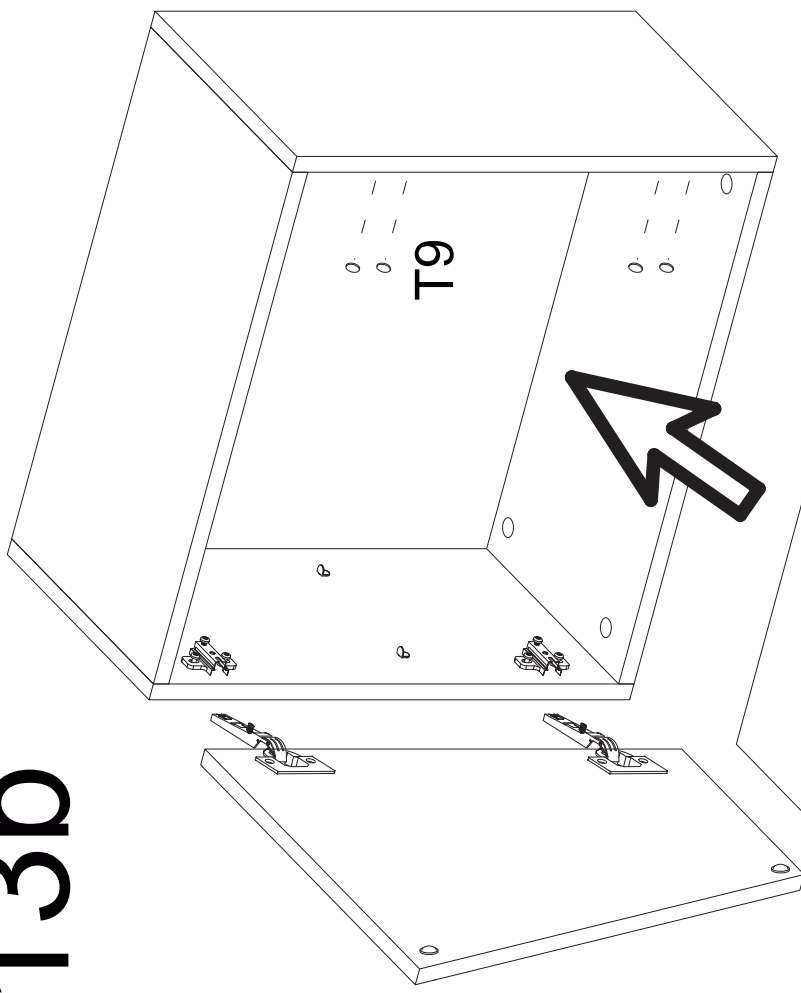

T9

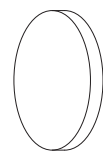

ø9

X4

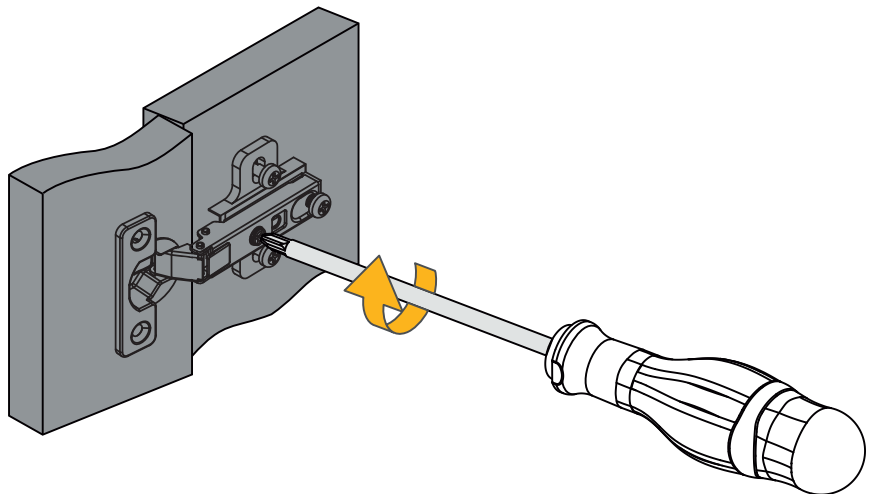
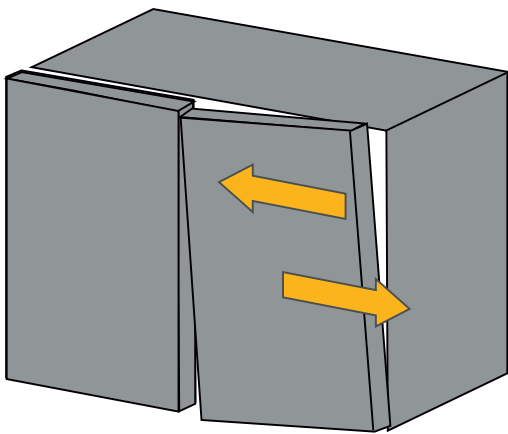
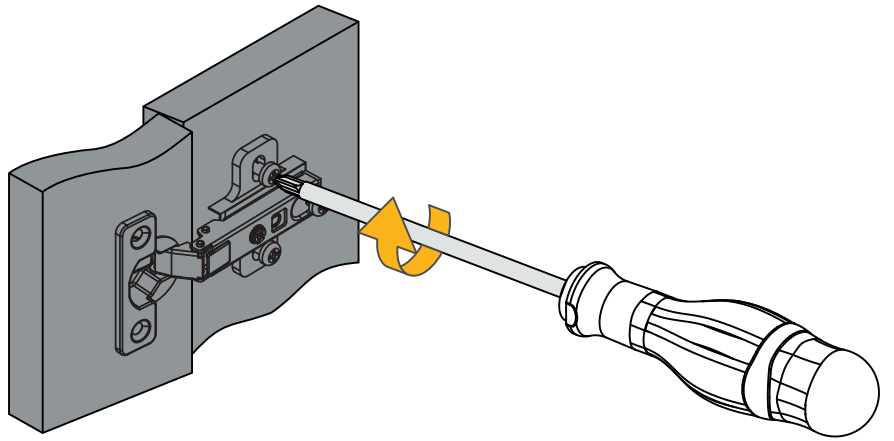
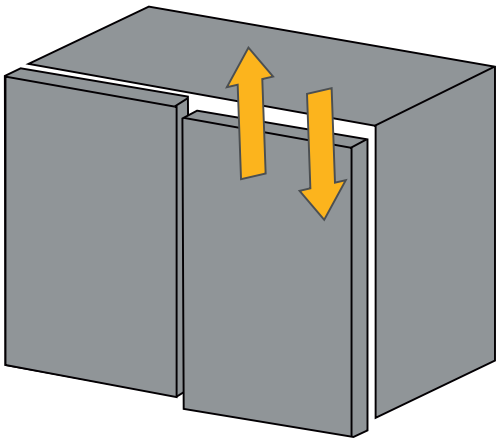
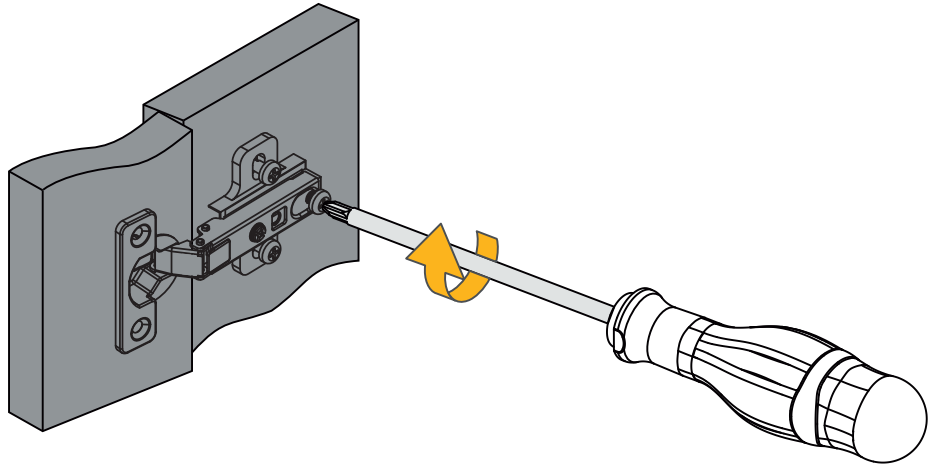
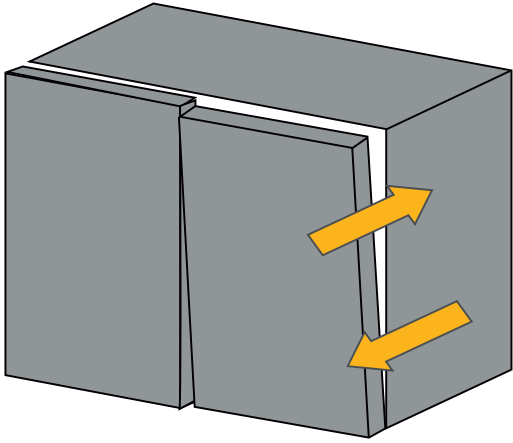

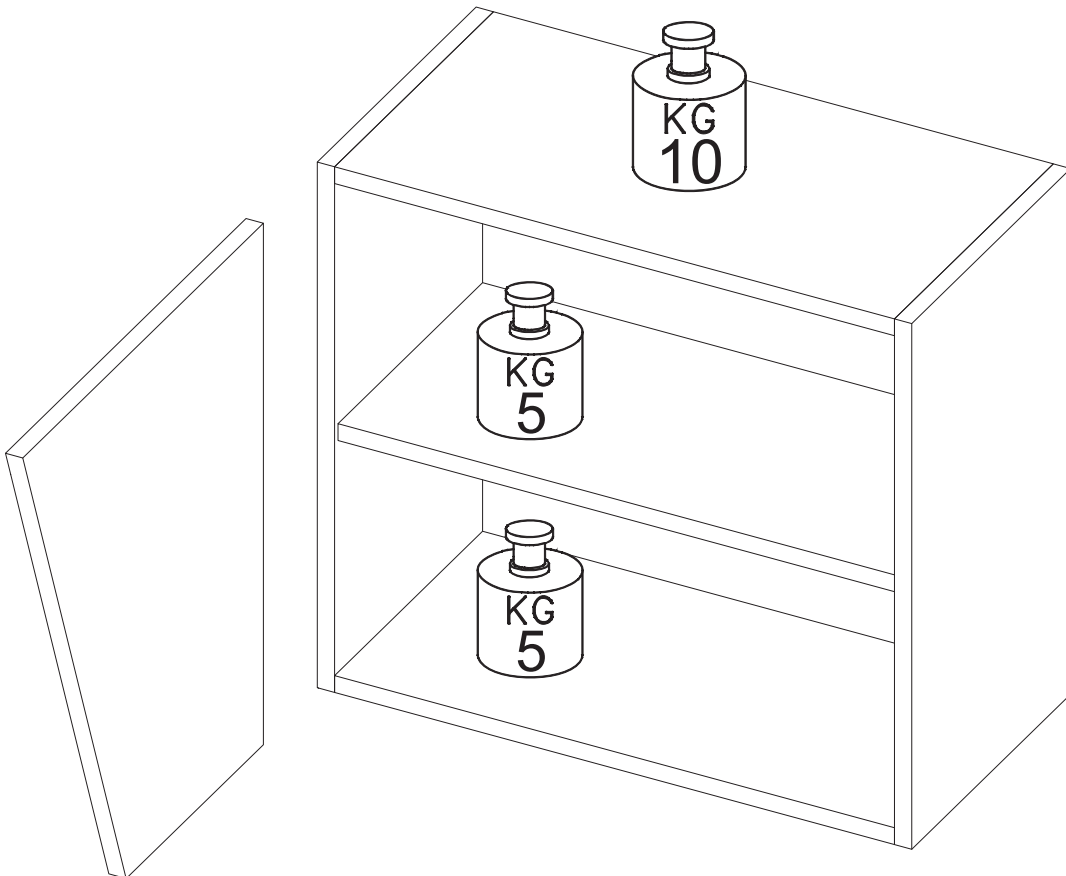
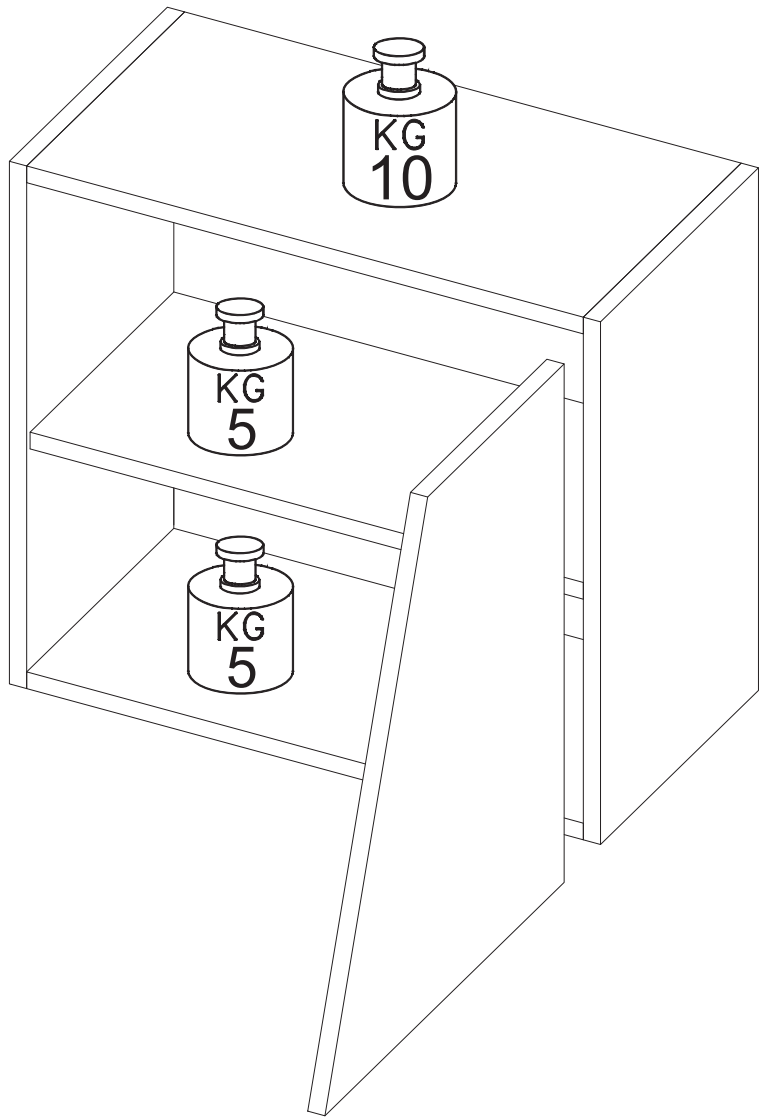

Montageanweisung / Installation instructions / Instruction de montage / Istruzioni di montaggio  
montagehandleiding / Instrukcja montażu / Montaj talimatlar / Osszeszerelési útmutató / Návod k montáži /  
Návod na montáž / Instrucțiune de montaj / Инструкция по монтажу / Montaj talimatina / Monteringsanvisningar  
Upute za montažu / Instrucciones de Montaje / Navodila za montažo

# INFINITY

## 2.0

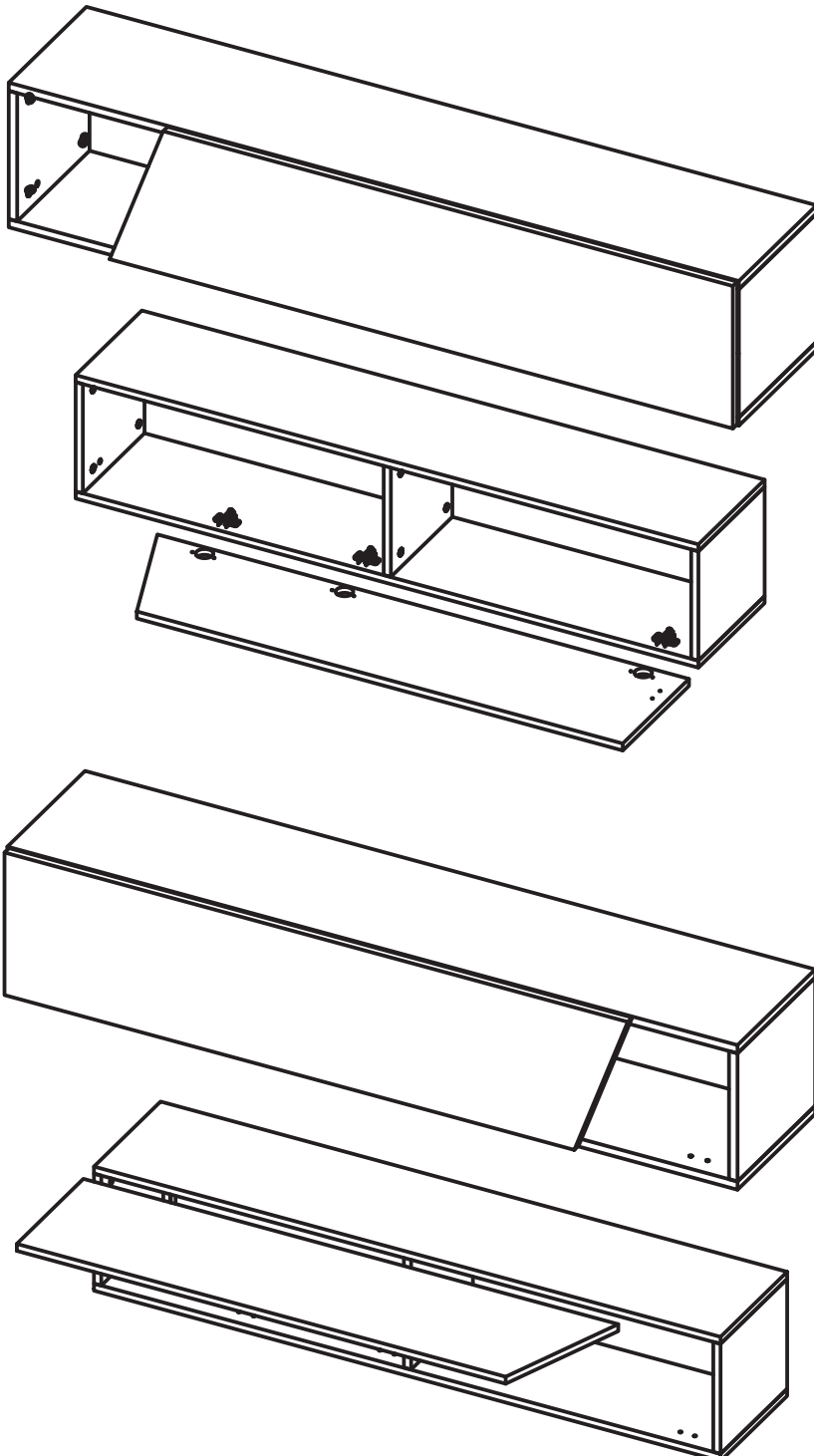
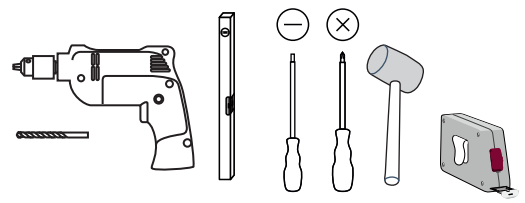
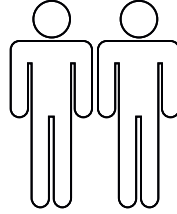
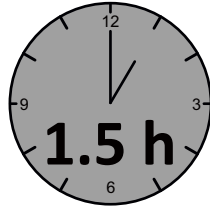

**D** – bitte lesen sie diese montageanleitung gut durch,  
Da wir für fehler, die durch falsche montage entstehen,  
Keine haftung übernehmen!

**Gb** – please read these installation instructions  
Through carefully as we cannot accept any liability  
For faults occurring as a result of incorrect installation!

**Cz** – přečtěte si prosím pozorně tento návod k montáži,  
Aby jste předešli chybám vzniklých špatnou montáží,  
Za které neručíme!

**F** – veuillez lire attentivement cette notice de montage,  
Car nous déclinons toute responsabilité en cas d'erreurs  
Découlant d'un montage erroné !

**I** – prego leggere attentamente le istruzioni per il montaggio,  
Poiché decliniamo qualsiasi responsabilità  
Per difetti derivanti da montaggio errato.

**S** - läs monteringsanvisningarna noggrant.  
Vi avsåger oss allt ansvar för defekter som  
Uppstår p.g.a. Felaktig montering.

**Hr** – pažljivo pročitajte upute za montažu,  
Jer otklanjamo svaku odgovornost za pogreške  
Nastale uslijed pogrešne montaže.

**Slo** – prosimo, da pozorno preberete navodila za montažo,  
Saj zavračamo vsakršno odgovornost za napake,  
Ki bi nastale zaradi napačne montaže.

**Nl** – leest u alstublieft deze montagehandleiding goed door,  
Voor fouten door verkeerde montage zijn wij niet verantwoordelijk.

**Pl** – prosze uwaznie zapoznac sie z instrukcja montazu,  
Poniewaz nie ponosimy odpowiedzialnosci za niewlasciwy montaz.

**Hu** – Kérjük, olvassa el figyelmesen  
ezt az összeszerelési útmutatót,  
mert a helytelen összeszerelésből  
a dódó hibákért nem vállalunk felelősséget!

**SK** – Prosíme, dobre prečítajte si tento návod na montáž,  
pretože nepreberáme žiadne ručenie za chyby,  
ktoré vzniknú na základe chybnej montáže!

**RO** – Vă rugăm să cititi cu atenție aceste instrucțiuni  
de montaj deoarece nu preluăm garanția pentru defecte  
ce apar datorită unui montaj incorect!

**RUS** – Пожалуйста, внимательно ознакомьтесь ù  
с данной инструкцией по монтажу, поскольку мы не  
несем ответственности за ошибки, причиной которых  
является неправильный монтаж.

**TU** – İlkonce kullanma klavuzunu iyi okuyun,  
yalnis montaj yapasaniz bunun sorumlusu biz degiliz.

**ES** – Se ruega leer con atención las instrucciones  
de montaje debido a que declinamos cualquier  
responsabilidad  
por defectos derivados de un montaje erróneo.

**SERVICEKARTE**

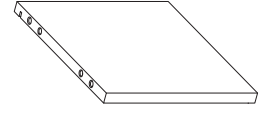
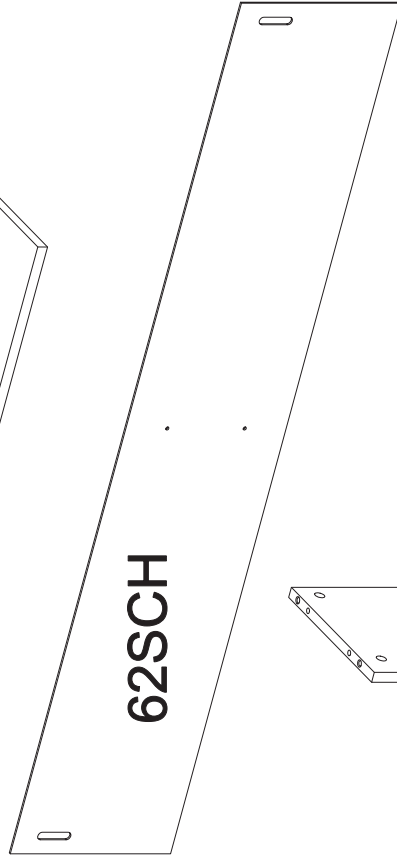
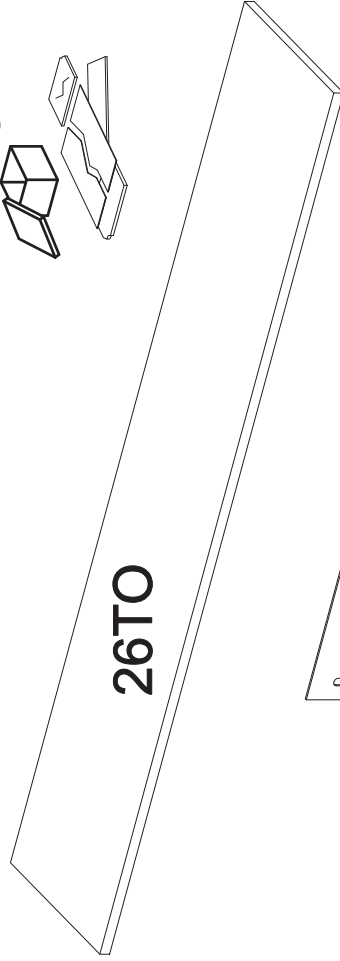
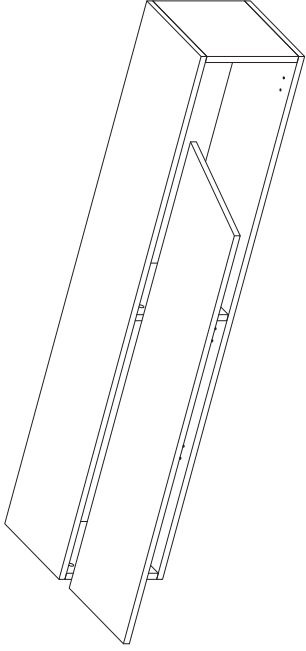
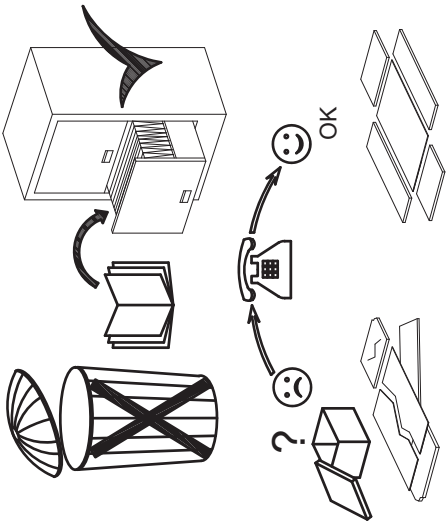

**62FI**

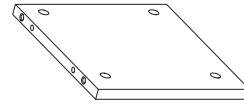

**62TR**

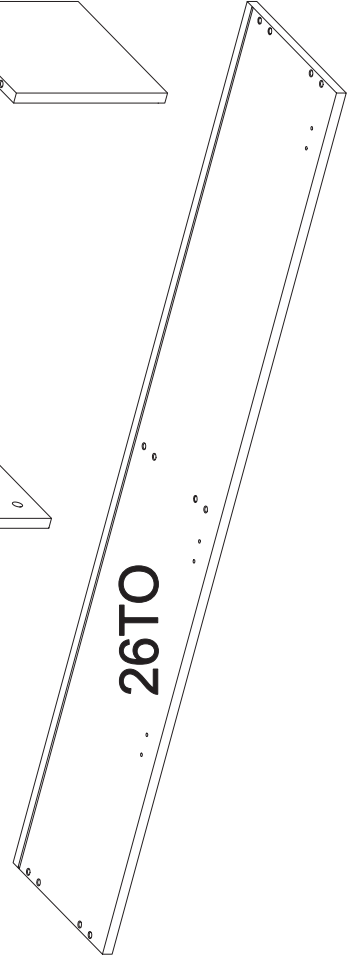

**26TO**

**62FI**

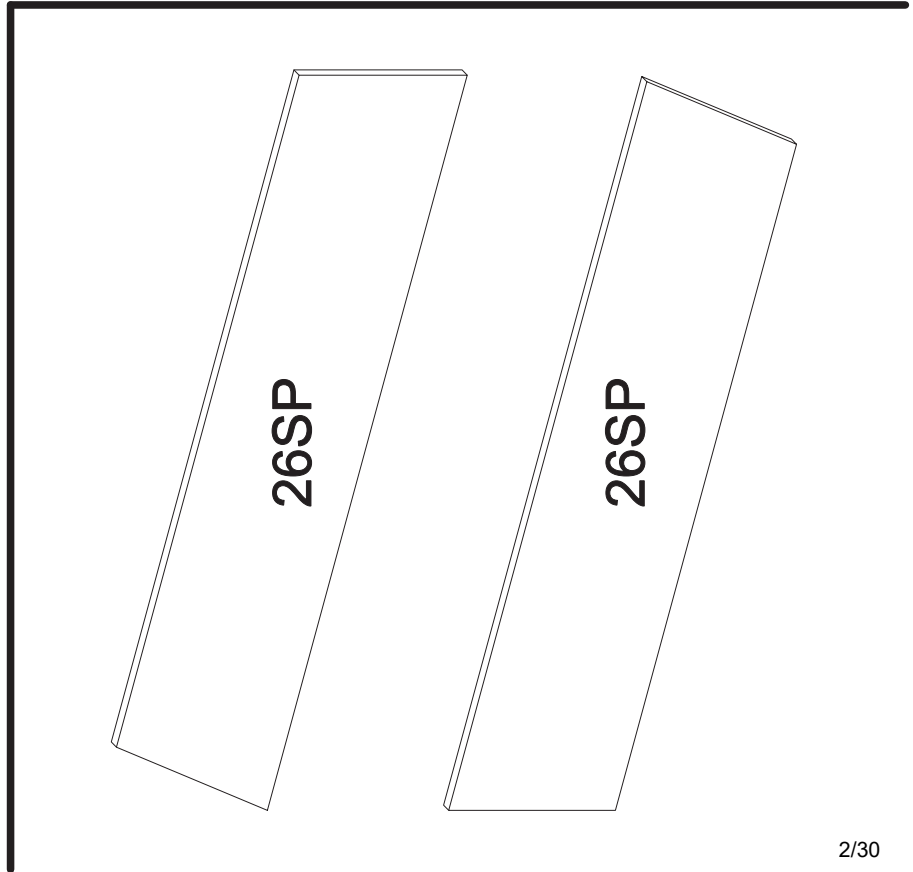
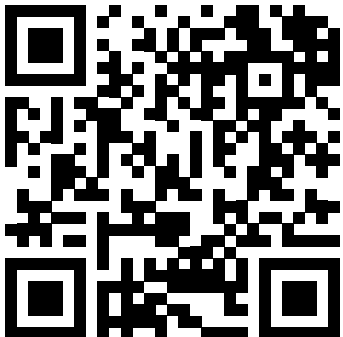
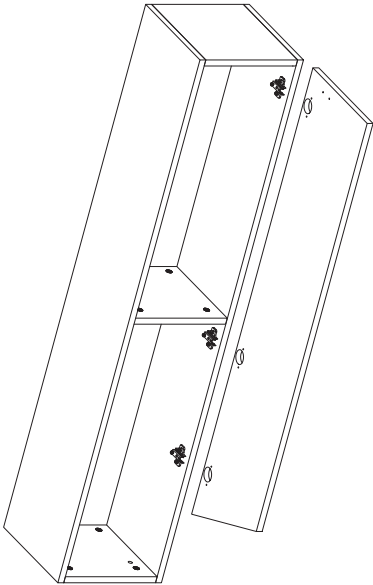
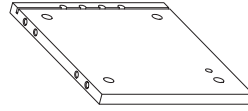

**26SP**

**26SP**

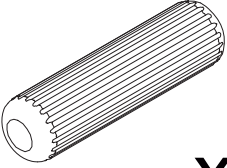
**B**  **x12**

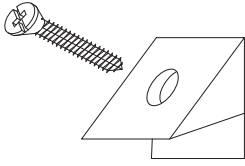
**F**  **x10**

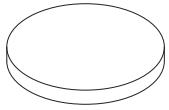
**T20**  **ø20 x5**

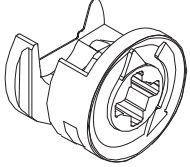
**C**  **ø15 x12**

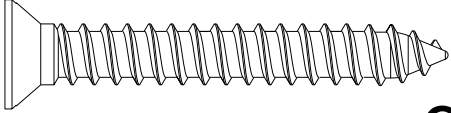
**V430** **ø4x30 mm**  **x3**

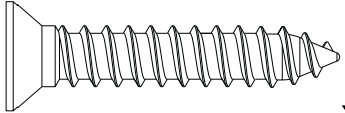
**V3520** **ø3.5x20 mm**  **x6**

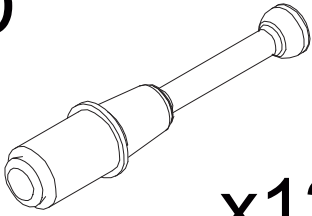
**D**  **x12**

**G**  **x2**

**ATS** **x1** 

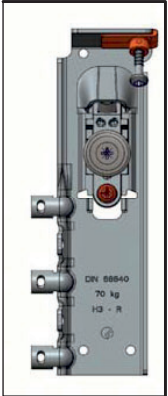
**ATD** **x1** 

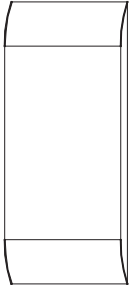
**TA**  **x2**

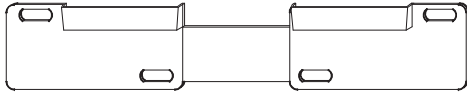
**ATD**  **x1**

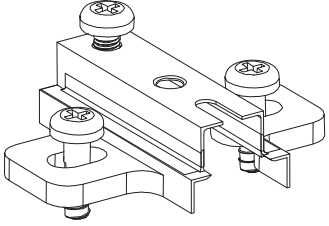
**H2E**  **x3**

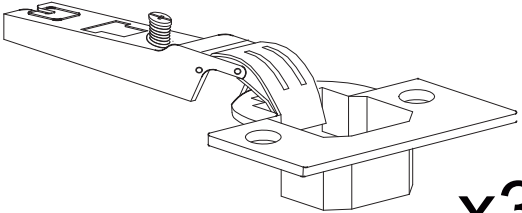
**C0**  **x3**

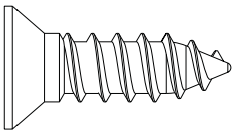
**V415** **ø4x15 mm**  **x6**

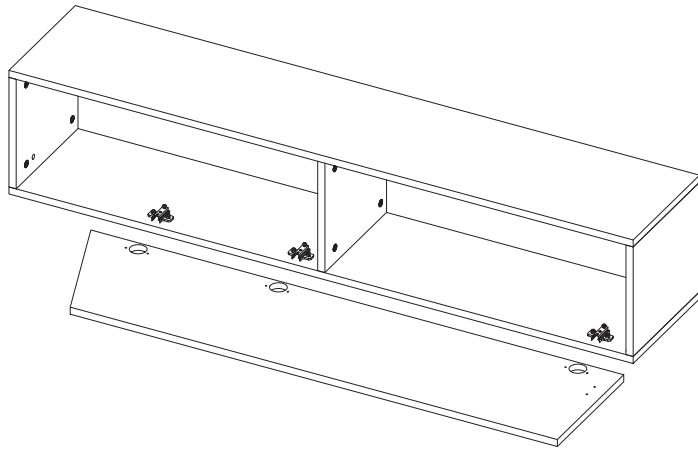

**K6**

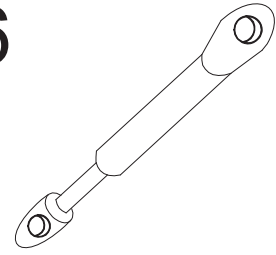

**x1**

**P18**

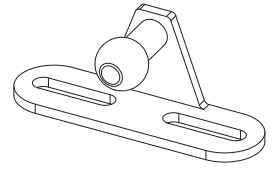

**x1**

**P19**

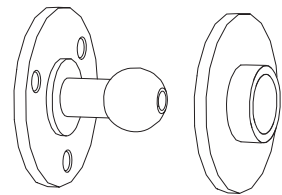

**x1**

**V316**

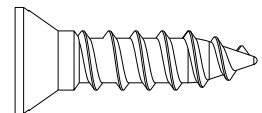

**ø3x16 mm**

**x5**

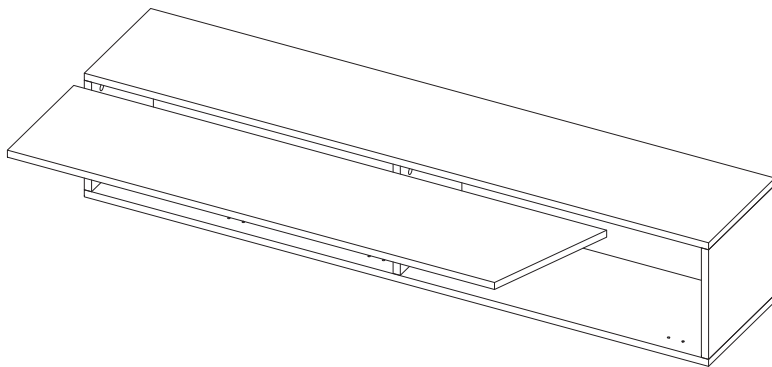
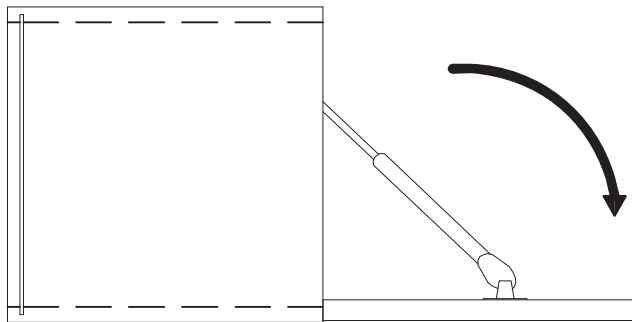

**K11**

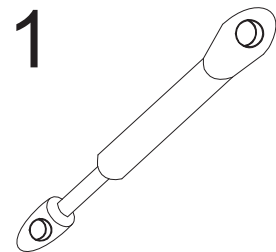

**x1**

**P18**

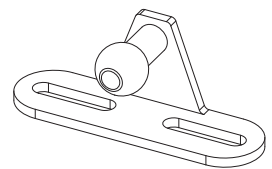

**x1**

**P19**

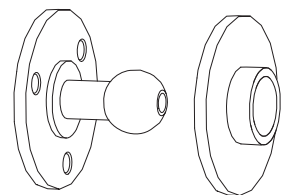

**x1**

**V316**

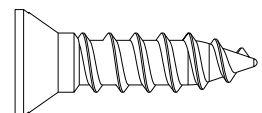

**ø3x16 mm**

**x5**

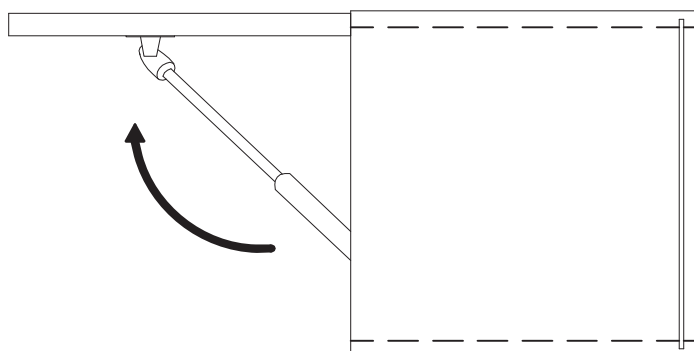

1

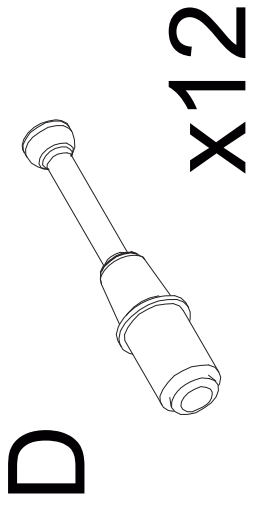
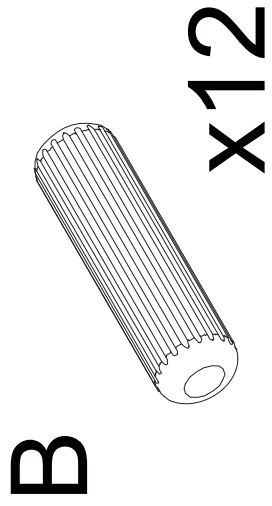
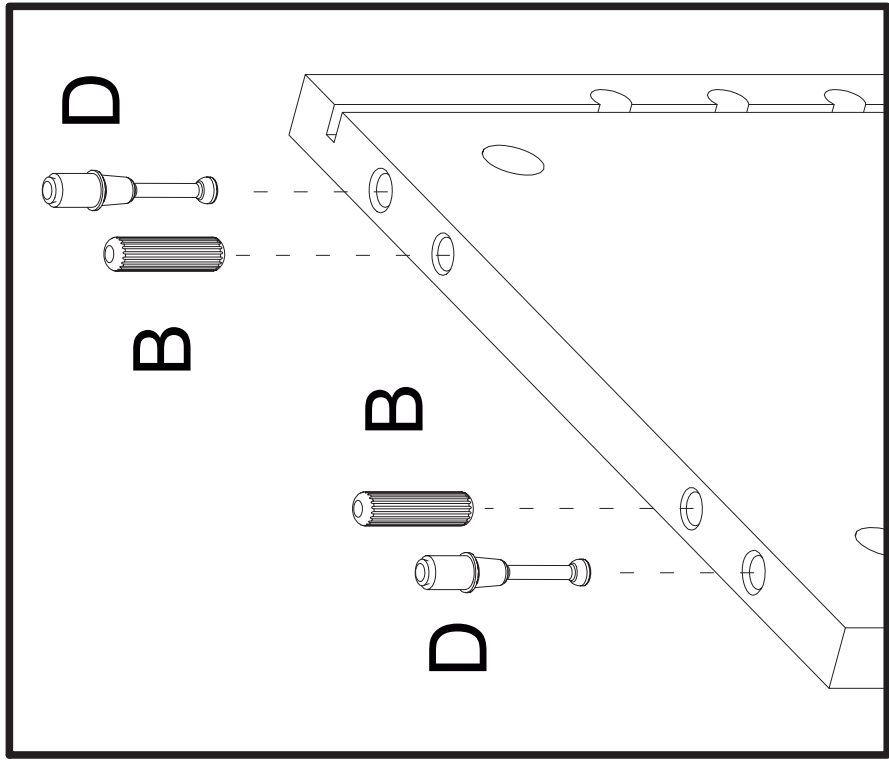
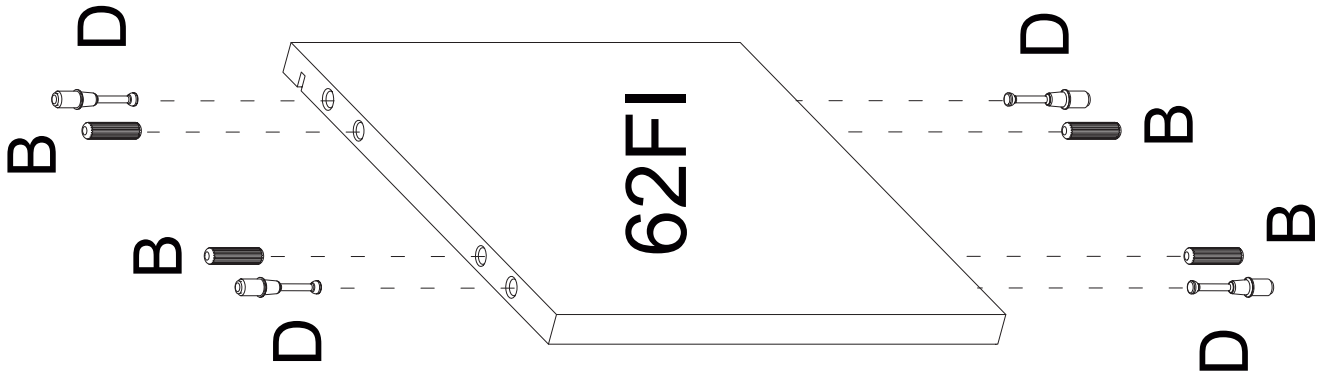
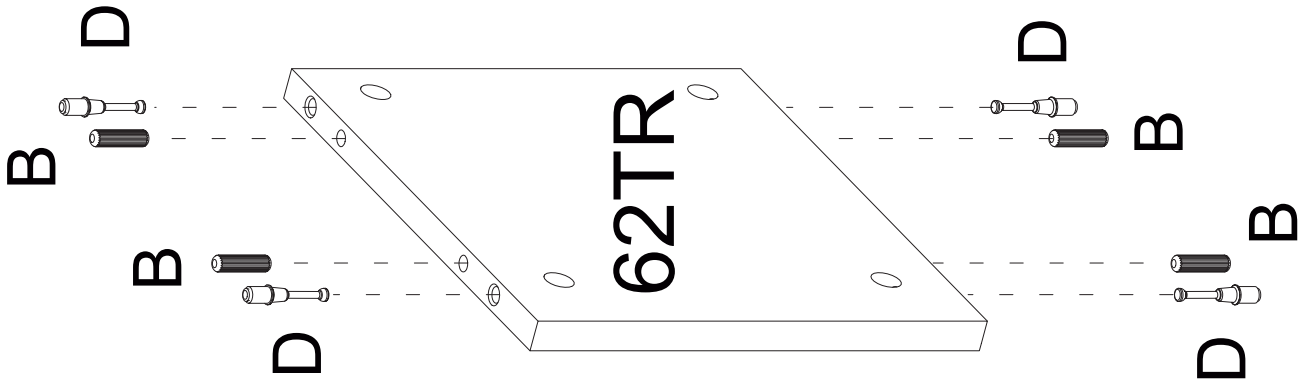
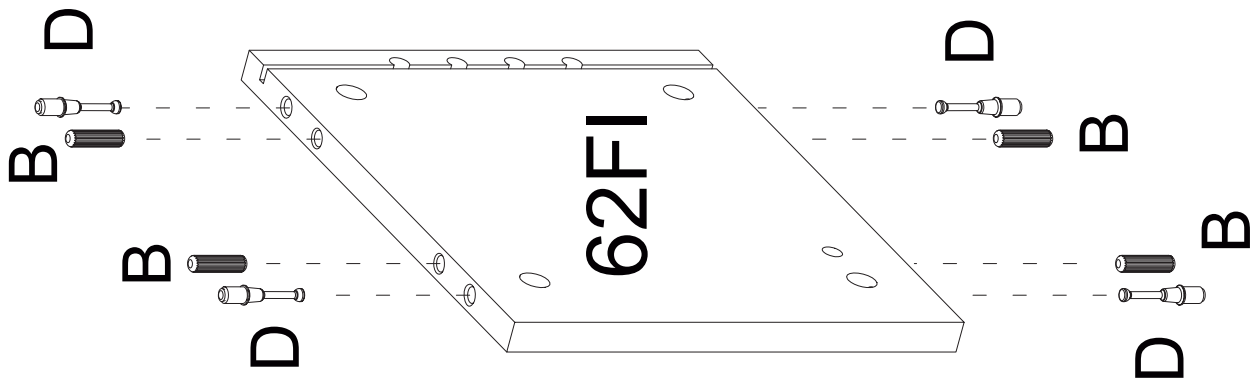



2

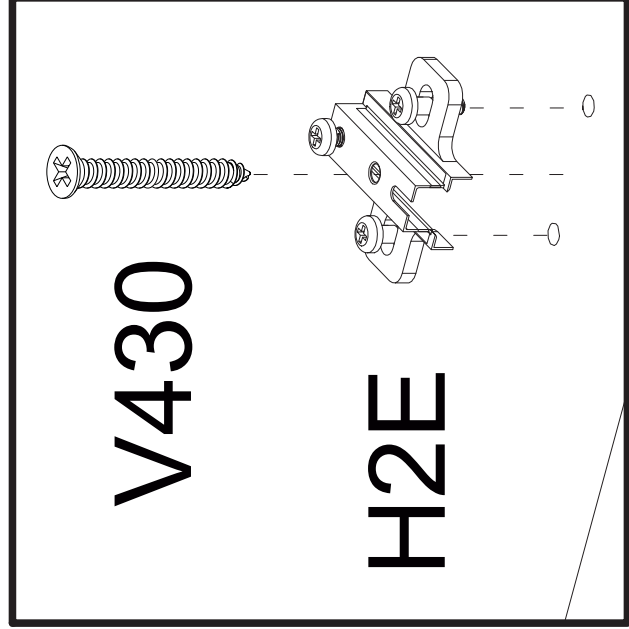
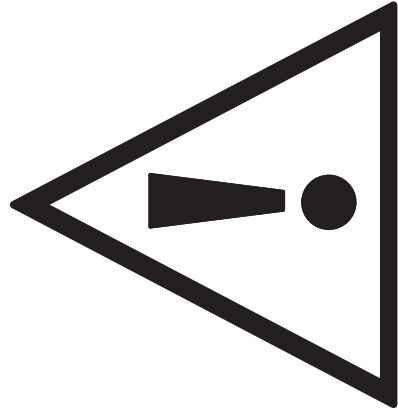

H2E

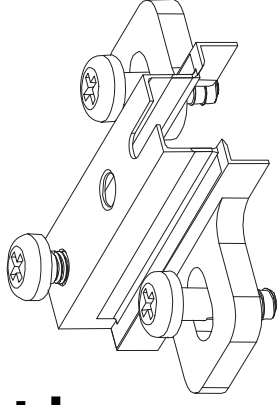

X3

V430

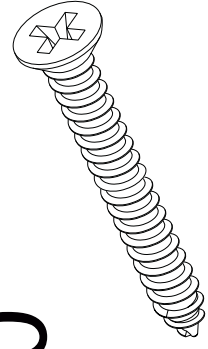

X3

V430



H2E

V430

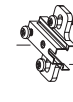

H2E

V430



H2E

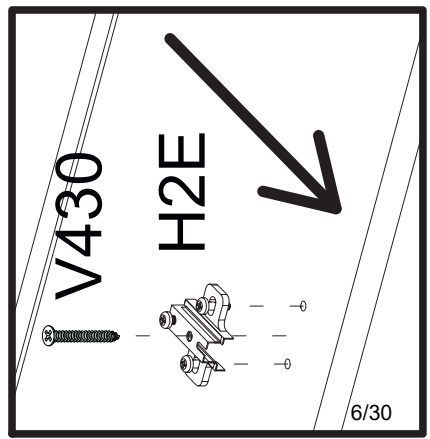
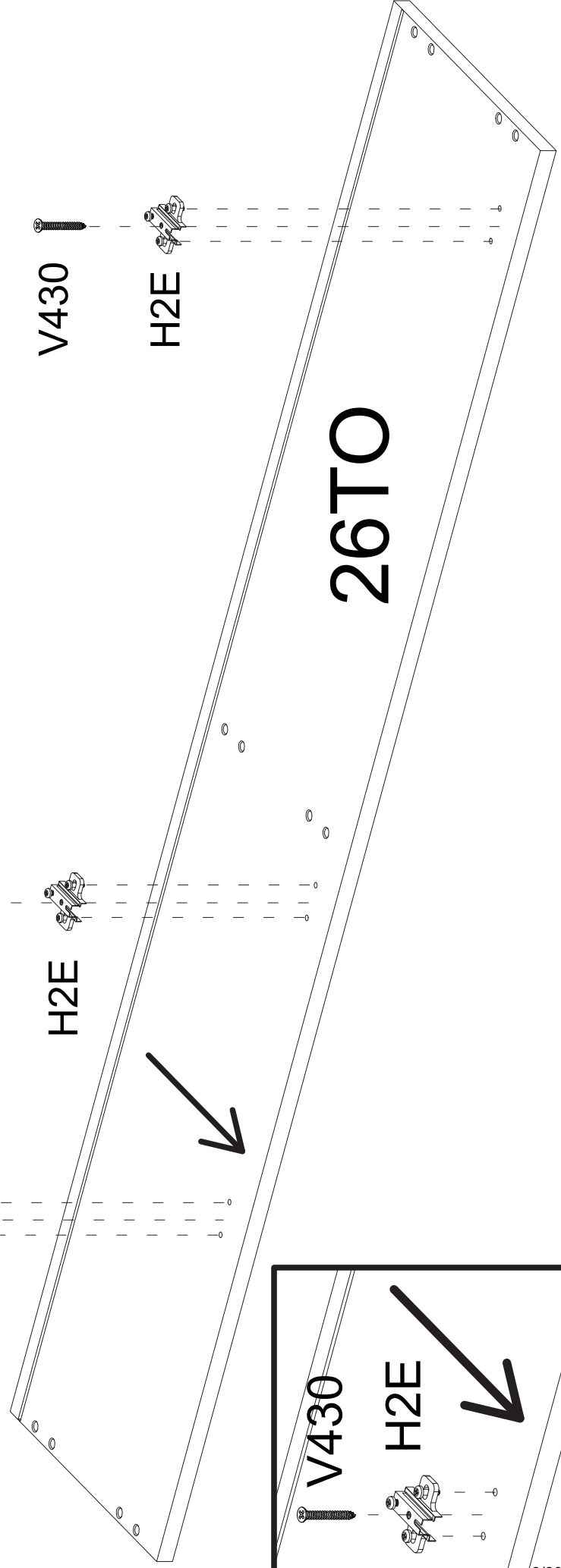

V430

H2E

3

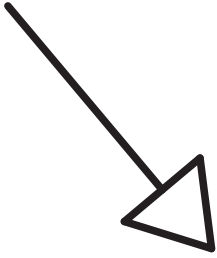

3a

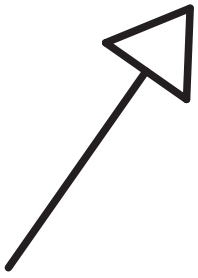
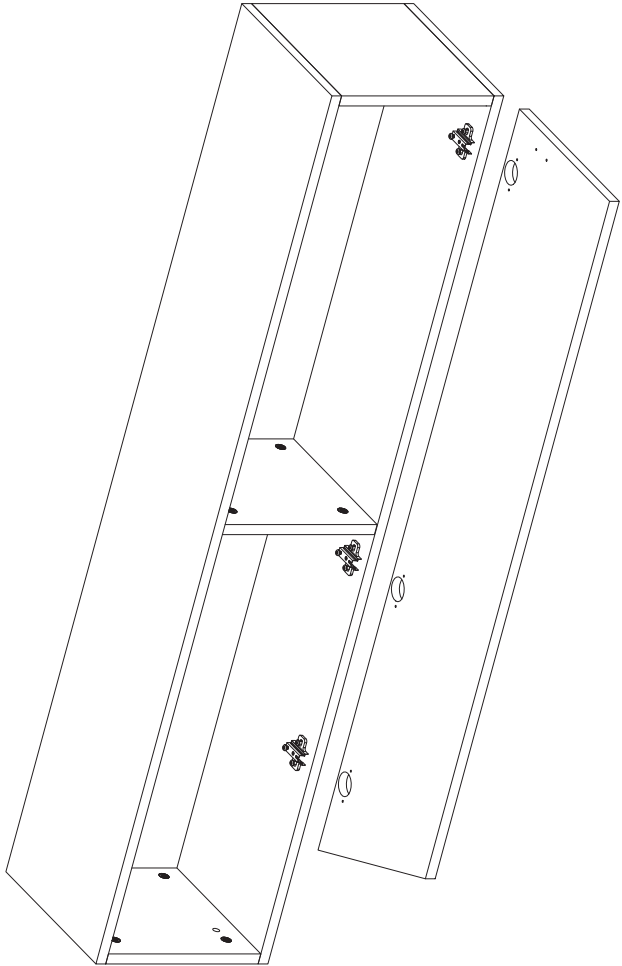

3b

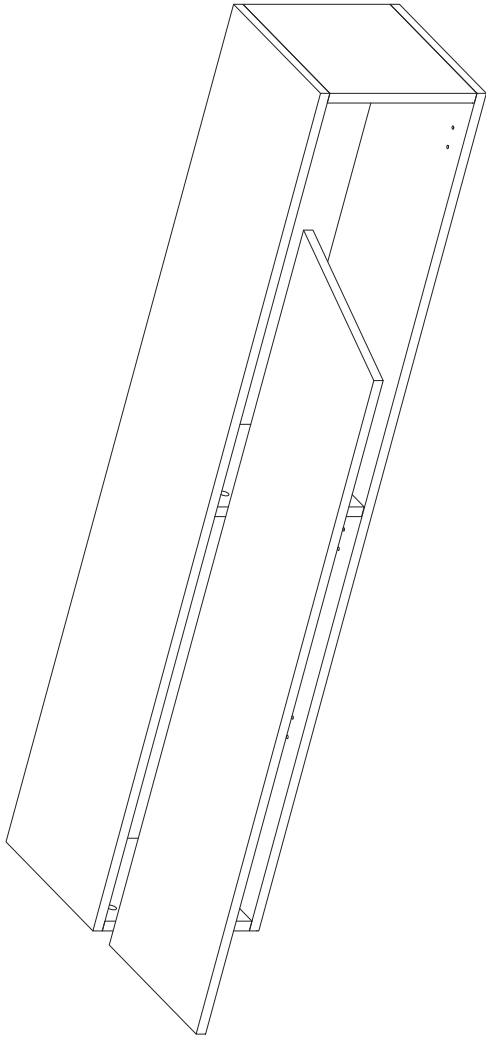

3a

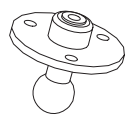
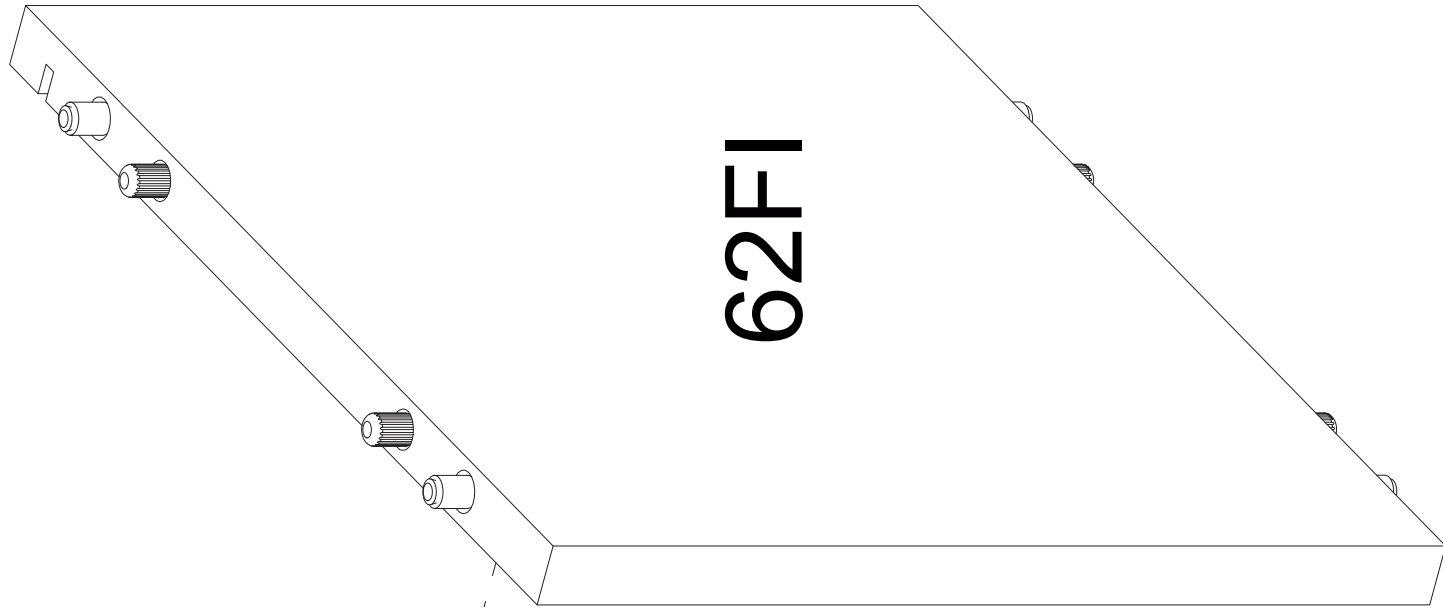

P19

+

V316 x3

P19

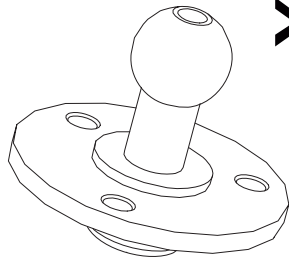

x1

V316

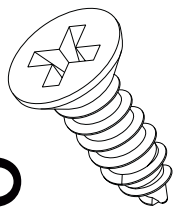

Ø3x16 mm

x3

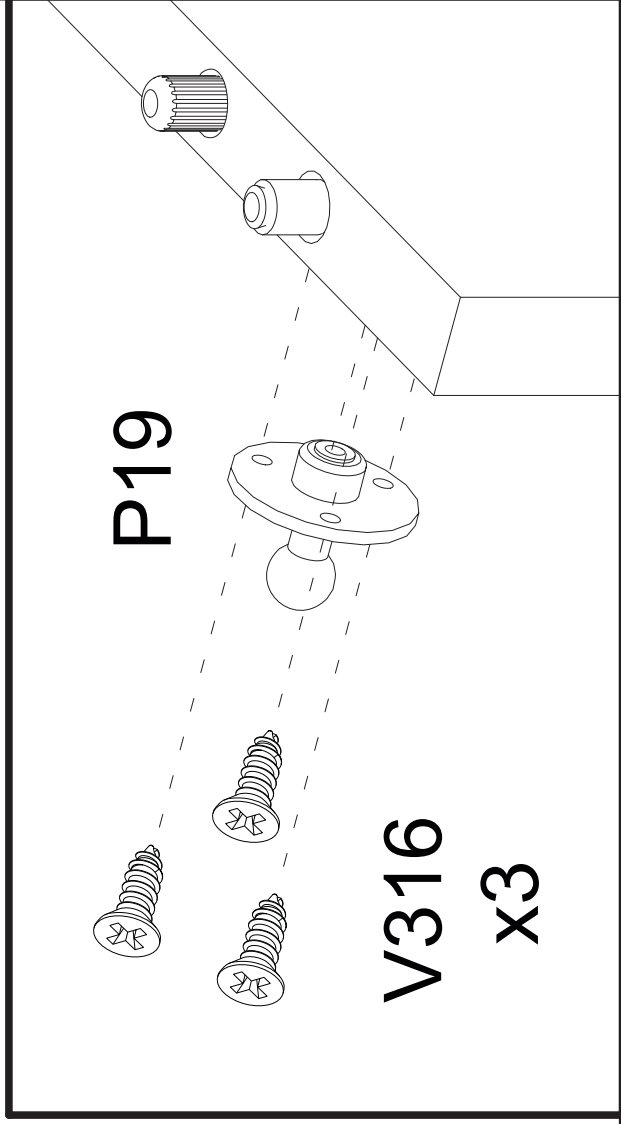
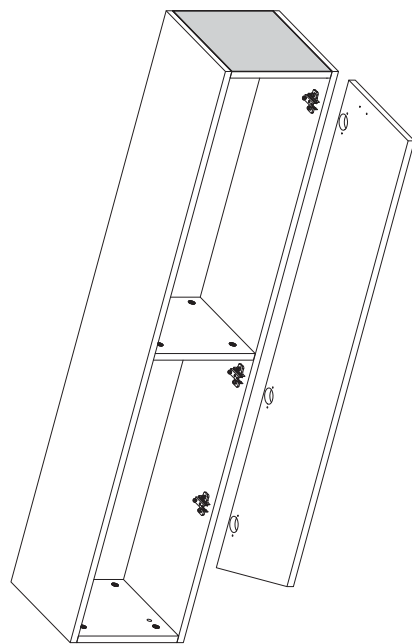

P19

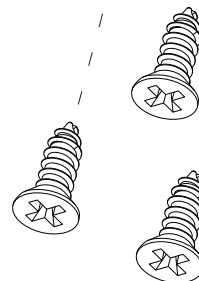

V316

x3



5a

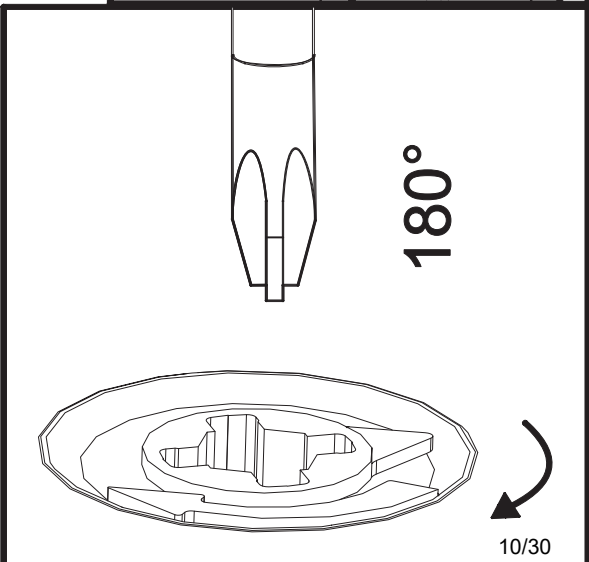
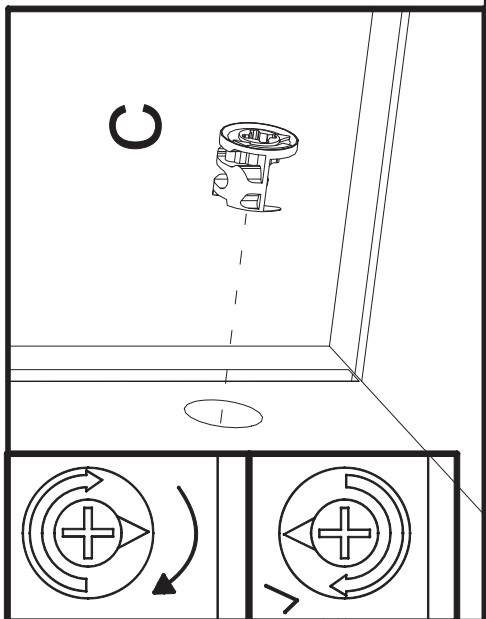
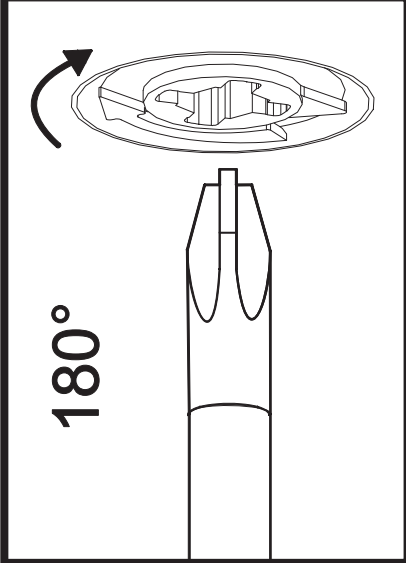
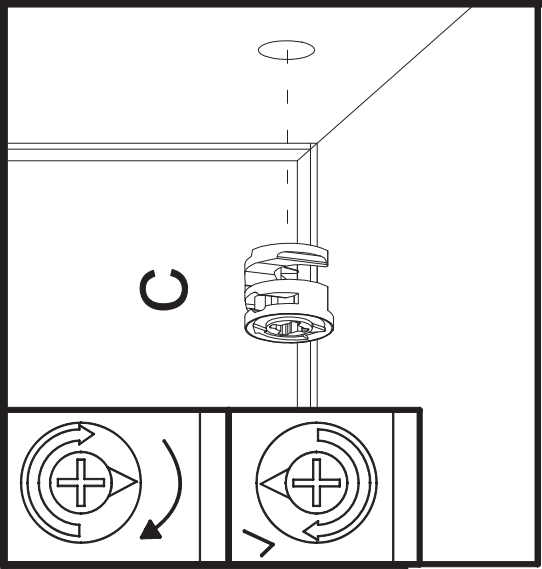
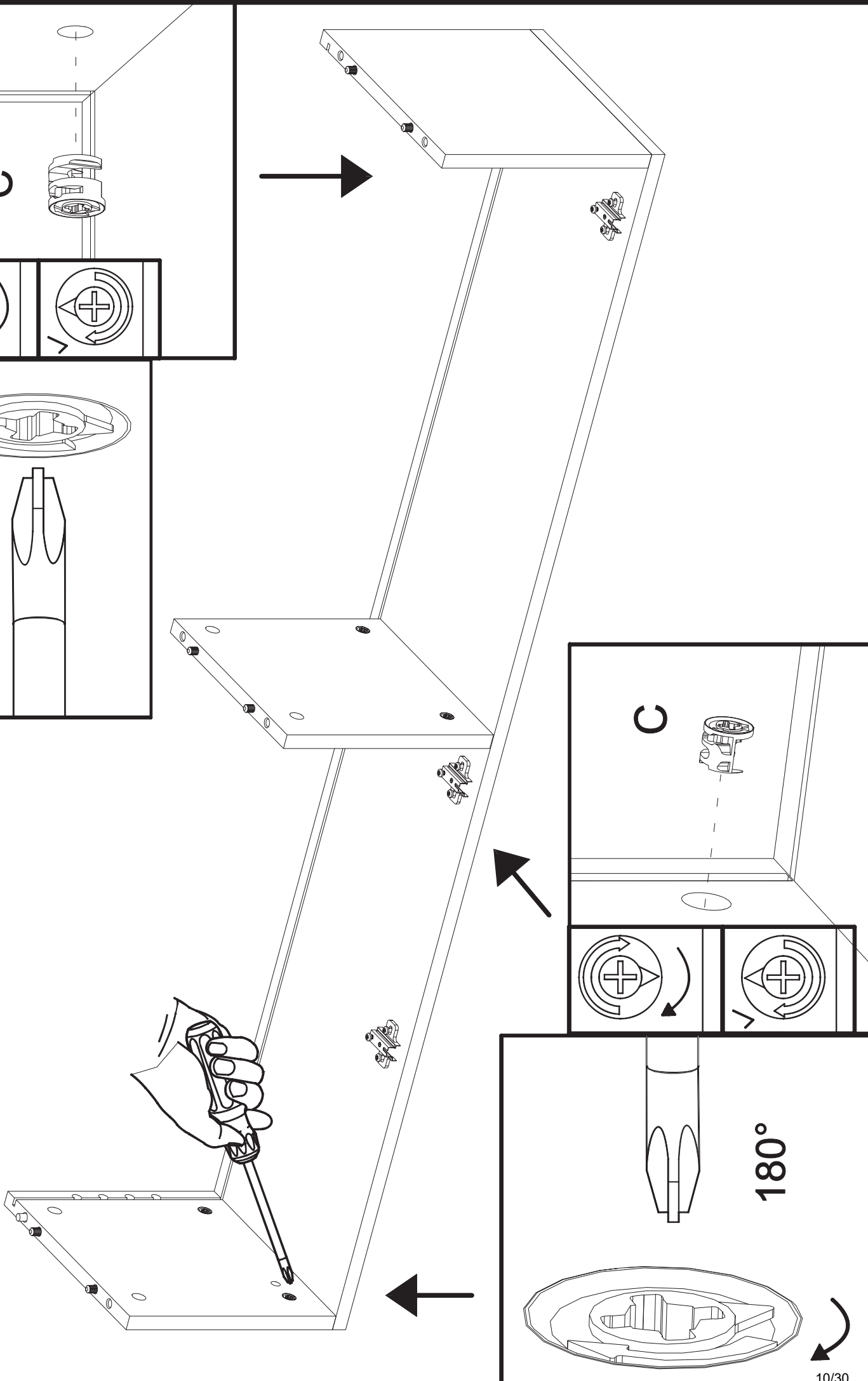

6a

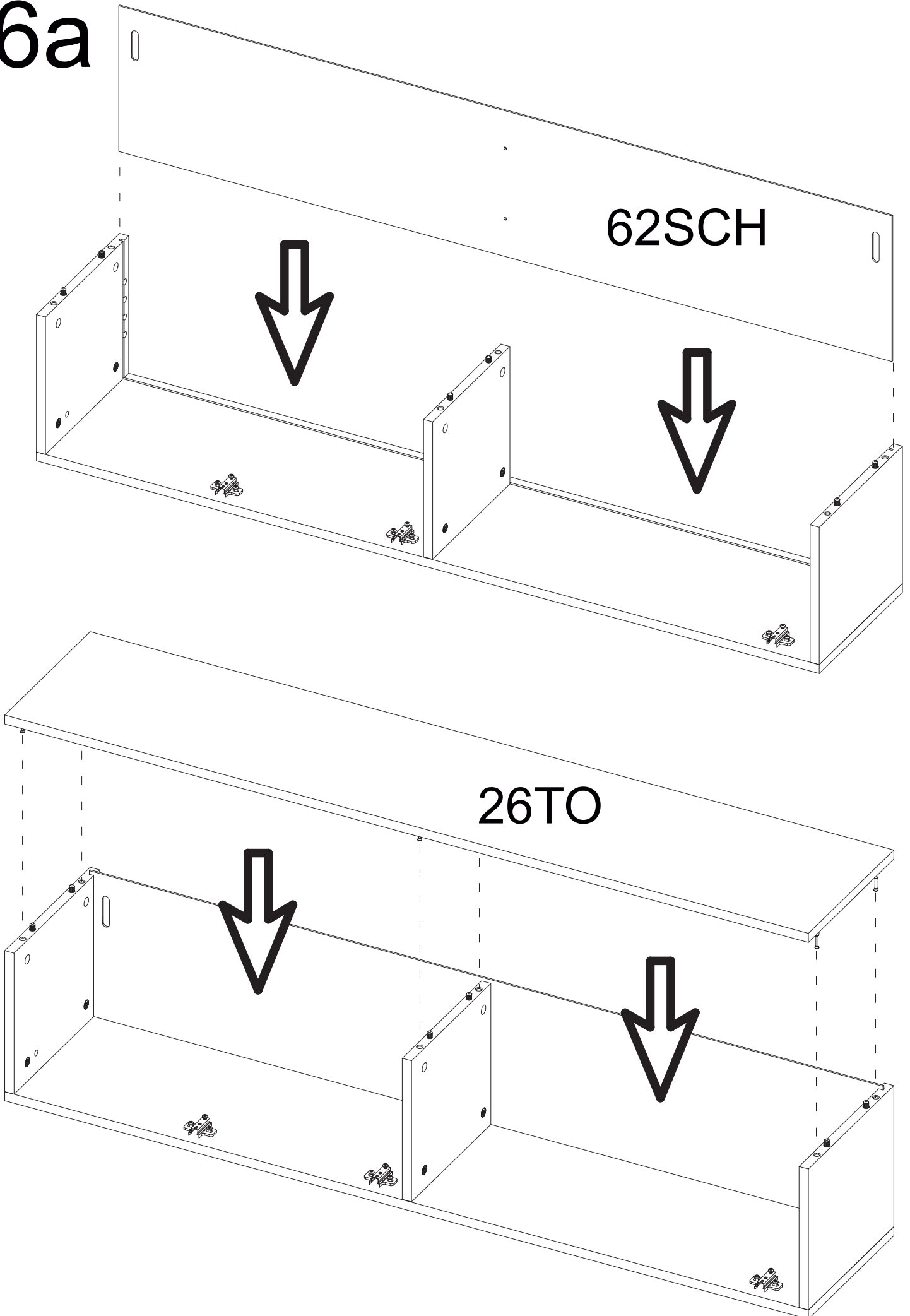



8a

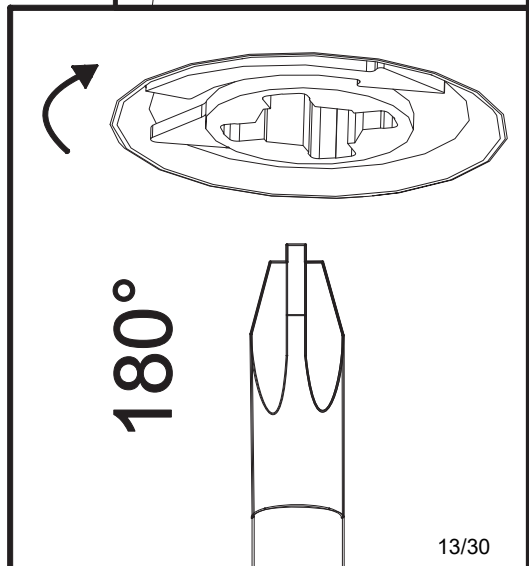
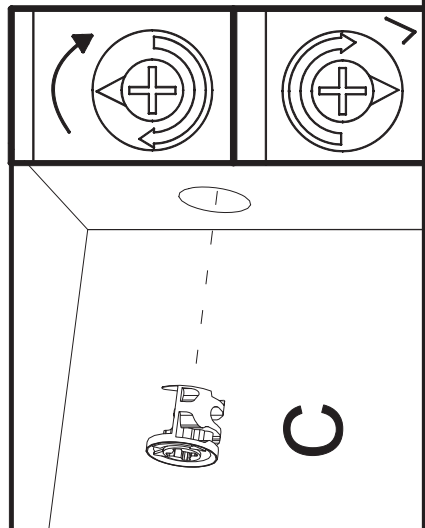
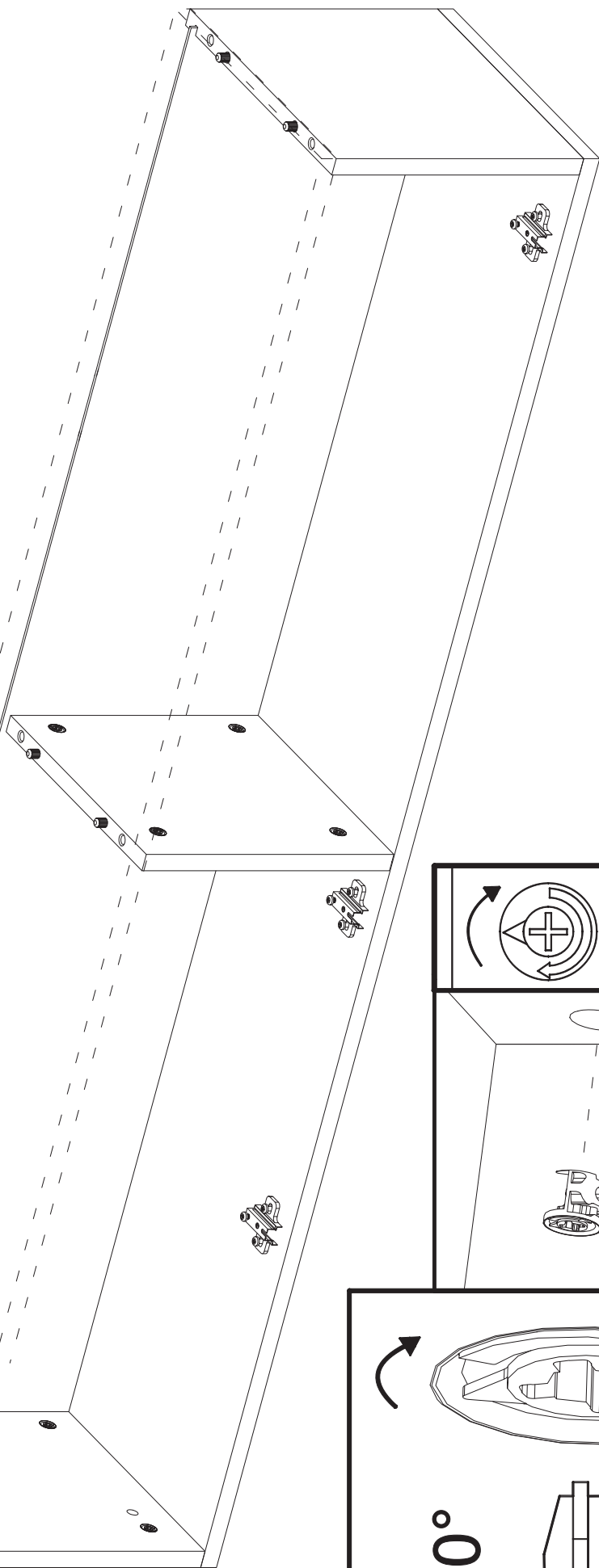
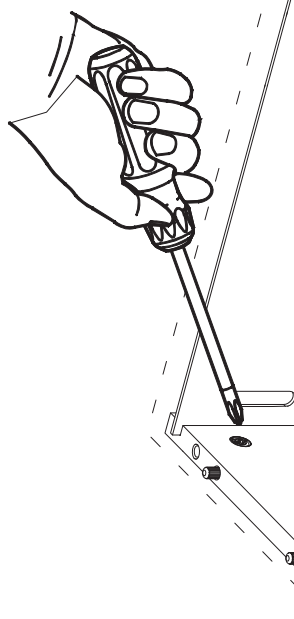
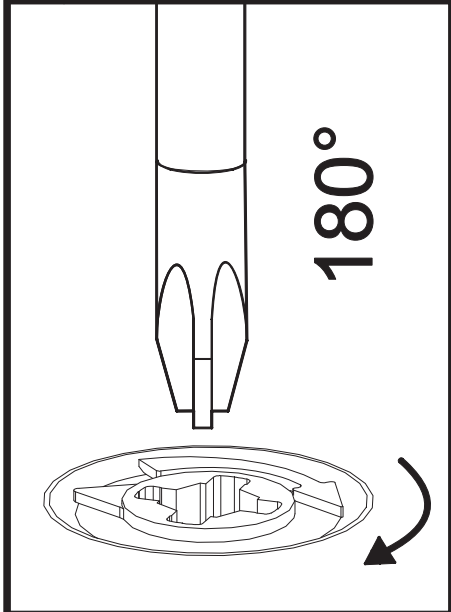
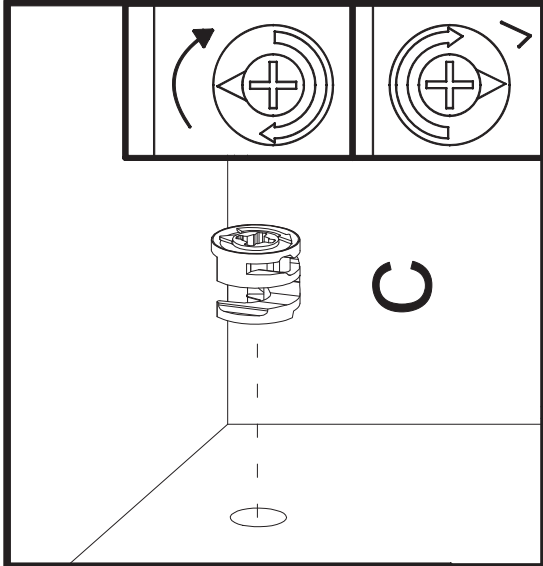



**3b**

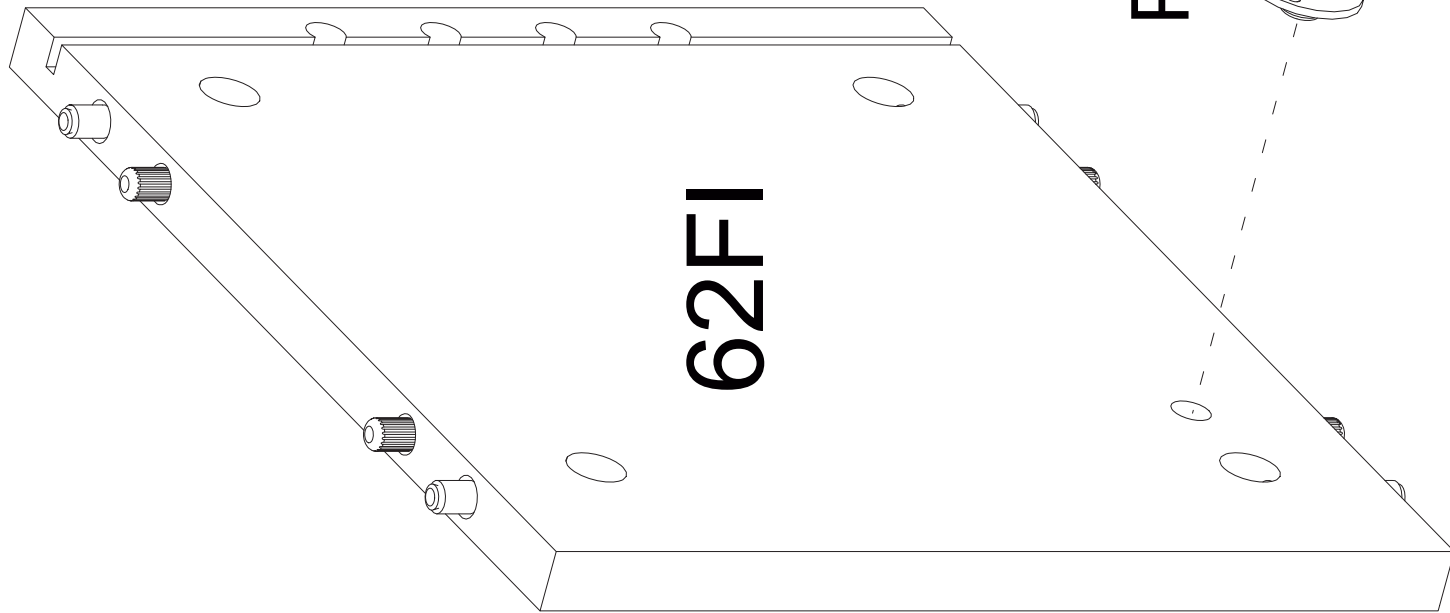

**P19**

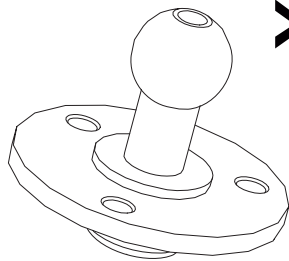

**x1**

**V316**

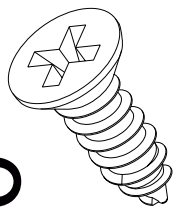

**Ø3x16 mm x3**

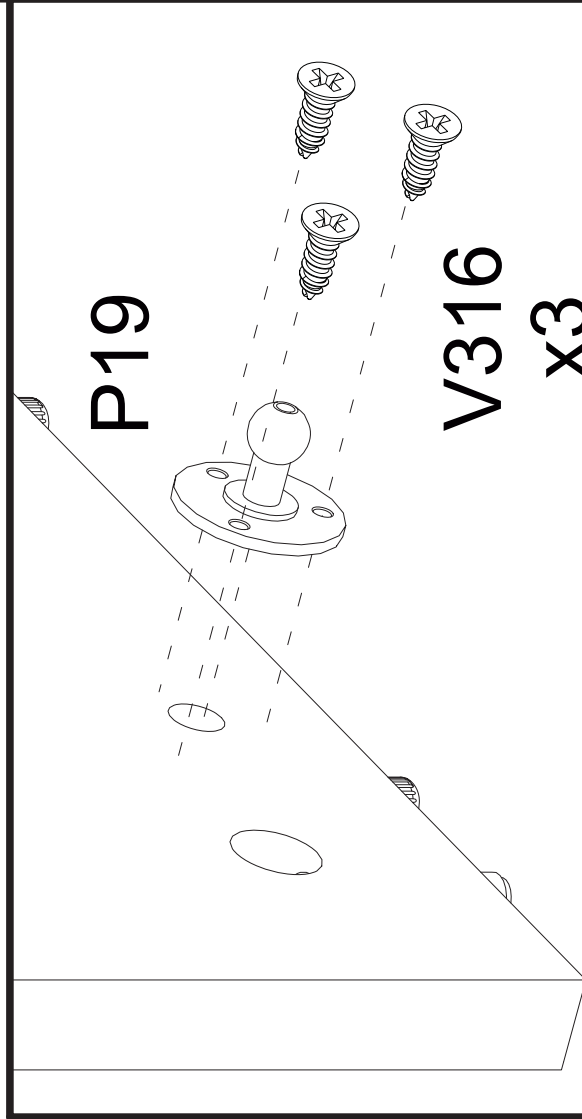
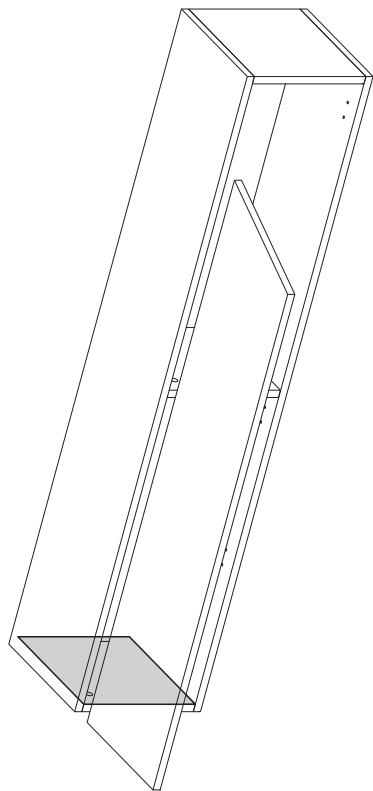

4b

C

x6

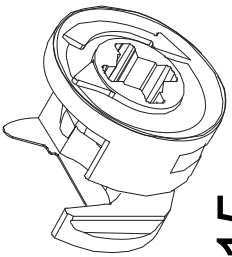

ø15



C

C



62FI

62TR

62FI

26TO

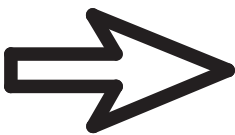

C

C

C C C

C C C

C

C

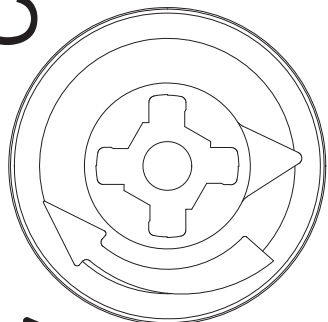

5b

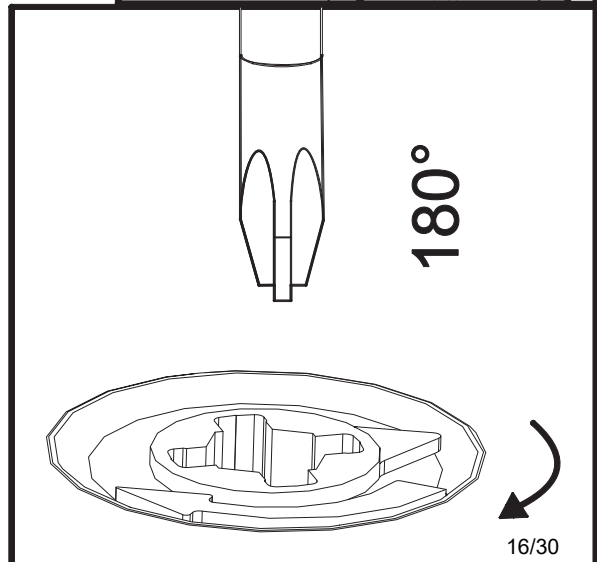
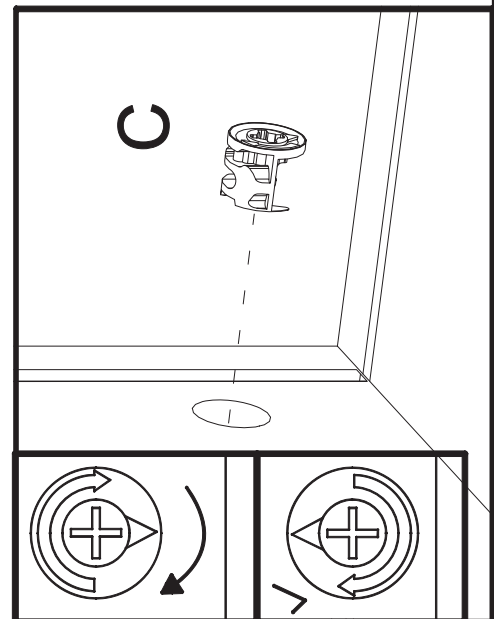
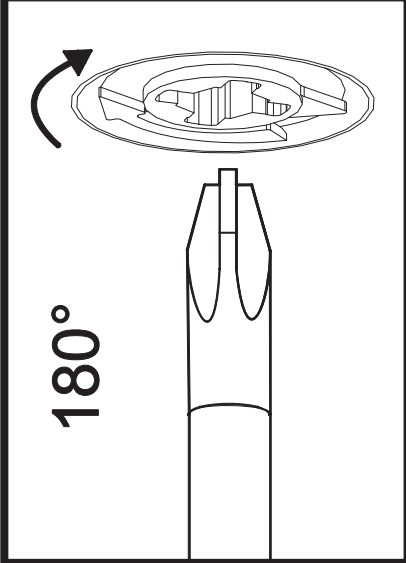
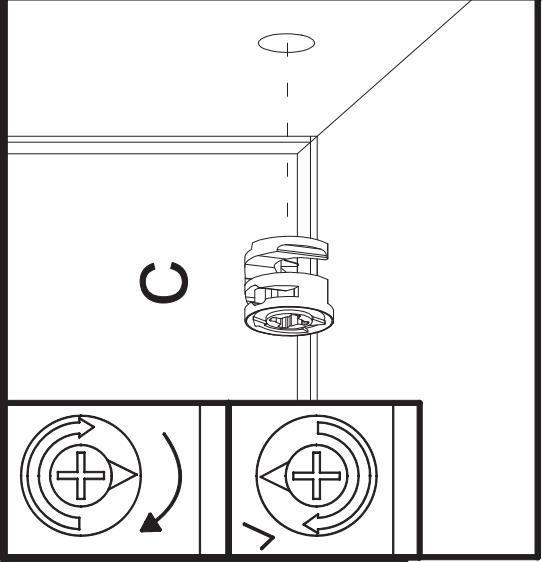
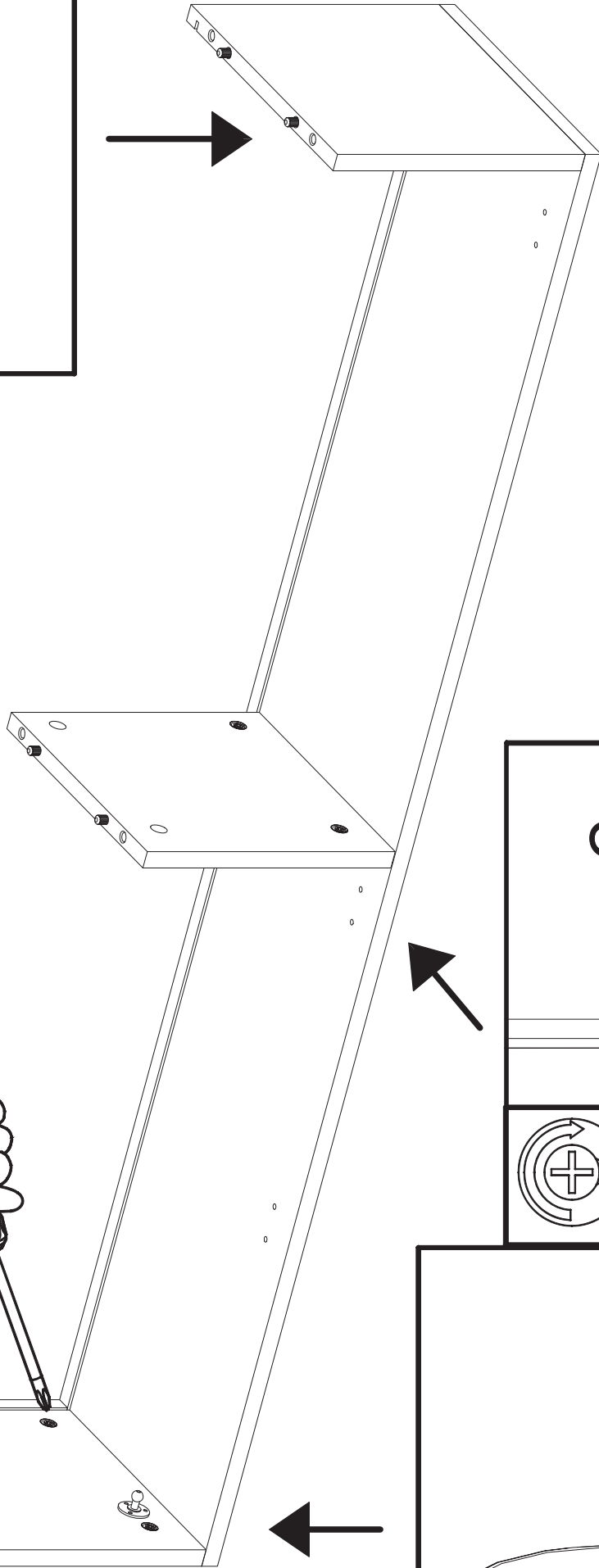
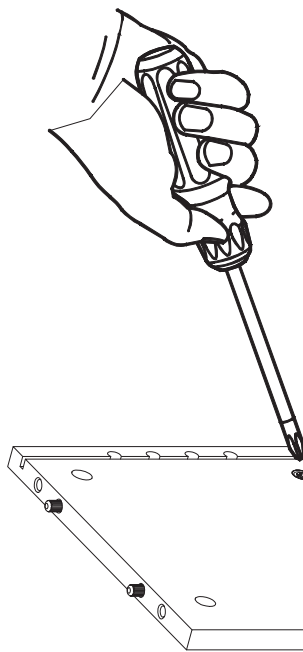

6b

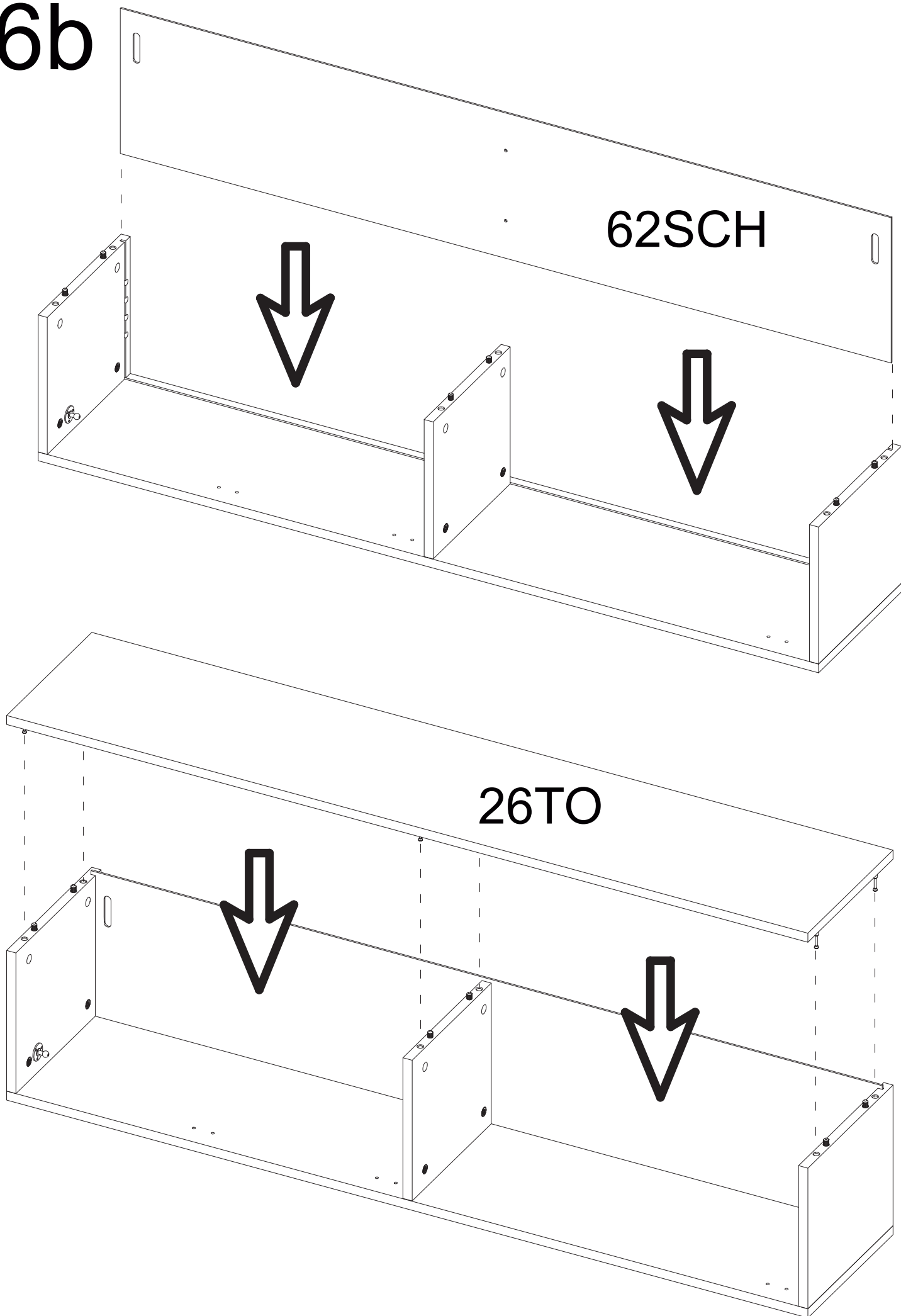

7b

x6

C

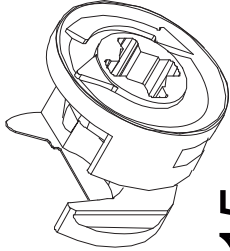

ø15

C

C

C

C

C

C

C

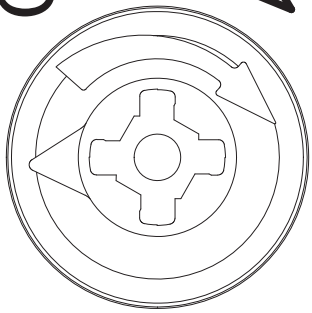

C

C

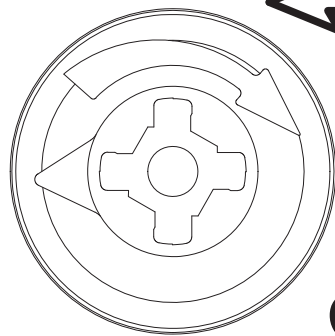

C

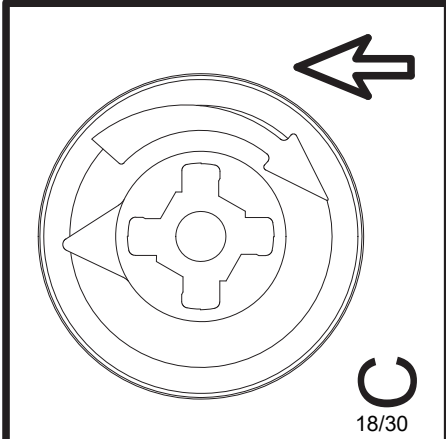
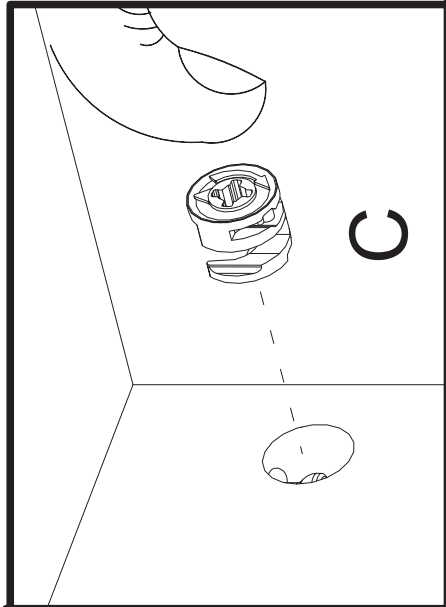
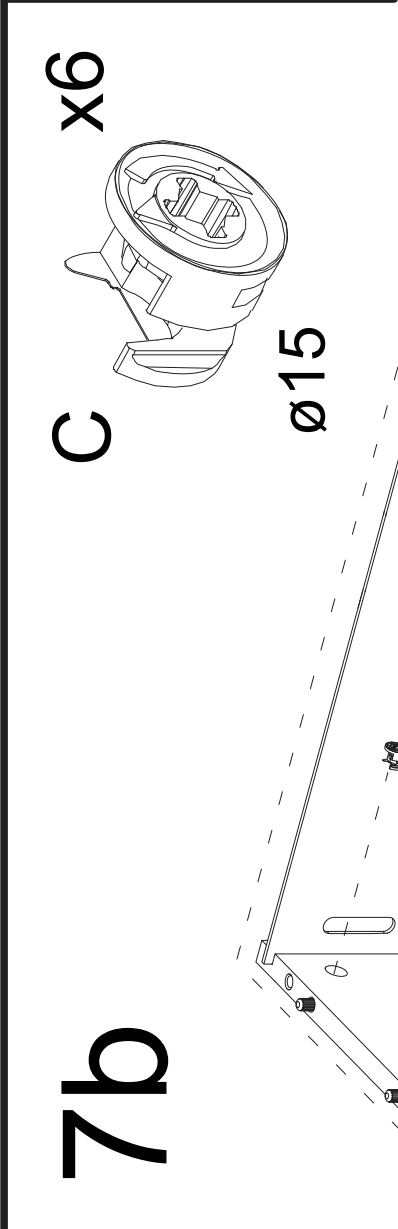
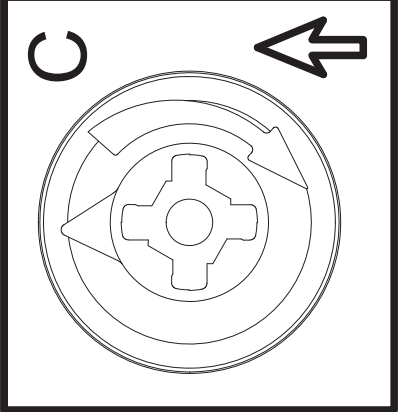
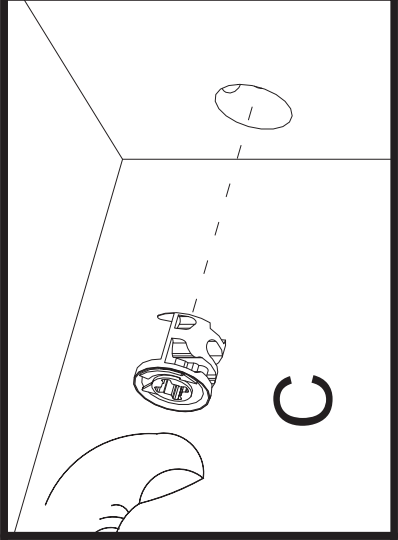

8b

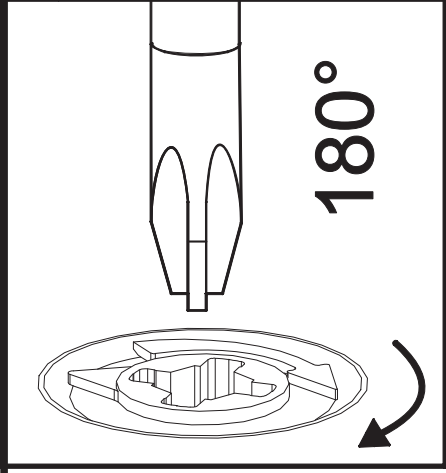
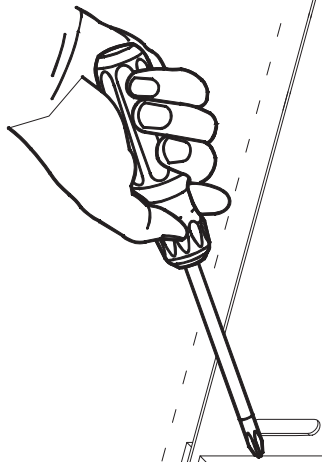

180°

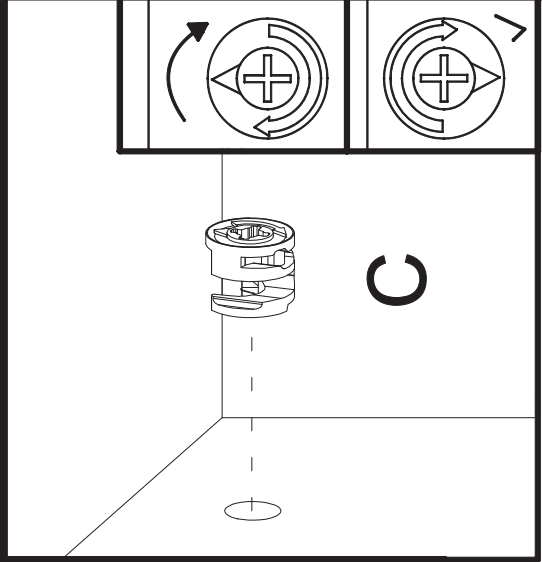

C

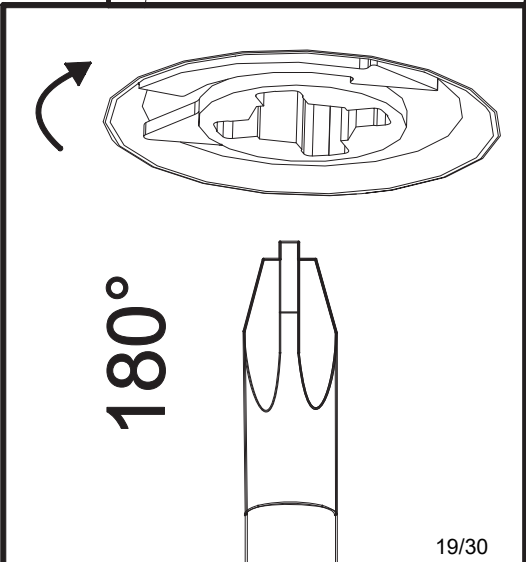
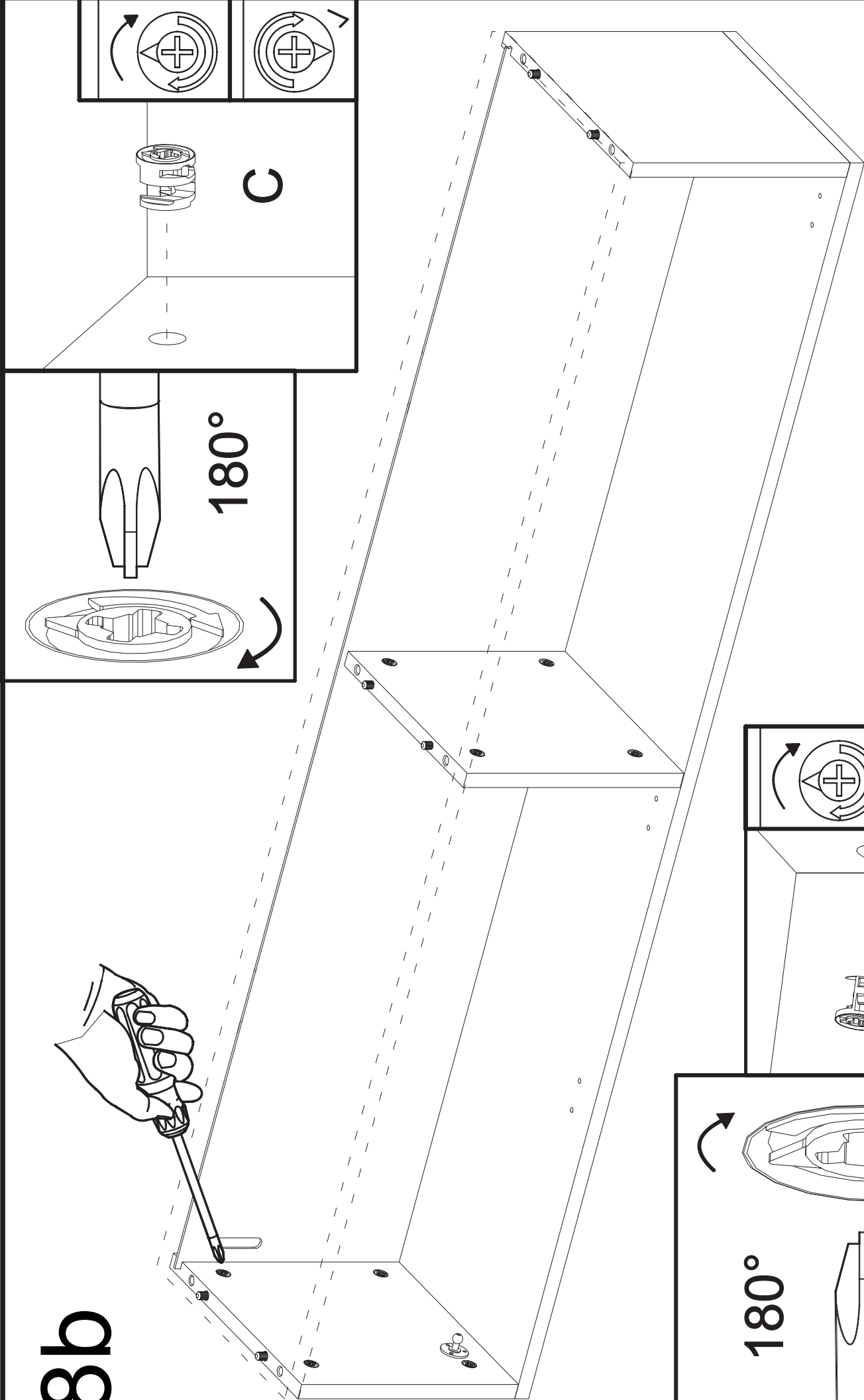

180°

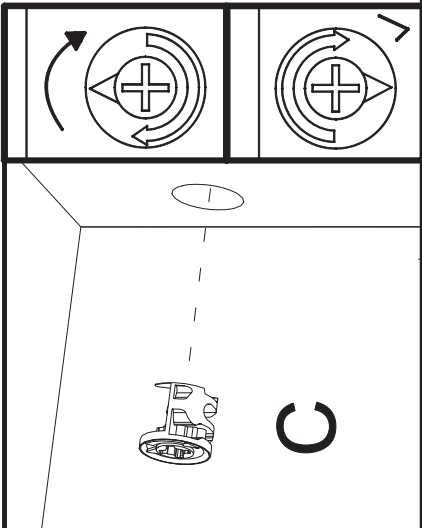

C

9

V3520

ø3.5x20 mm

x2

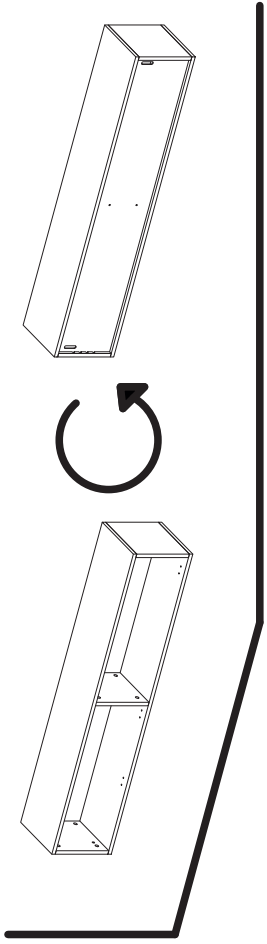

100 mm

180 mm

100 mm

180 mm

90°

F

V3520

V3520

x10

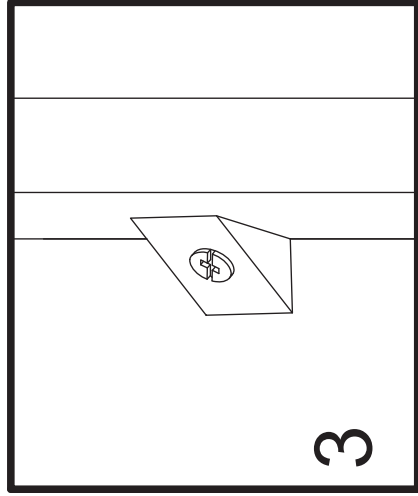
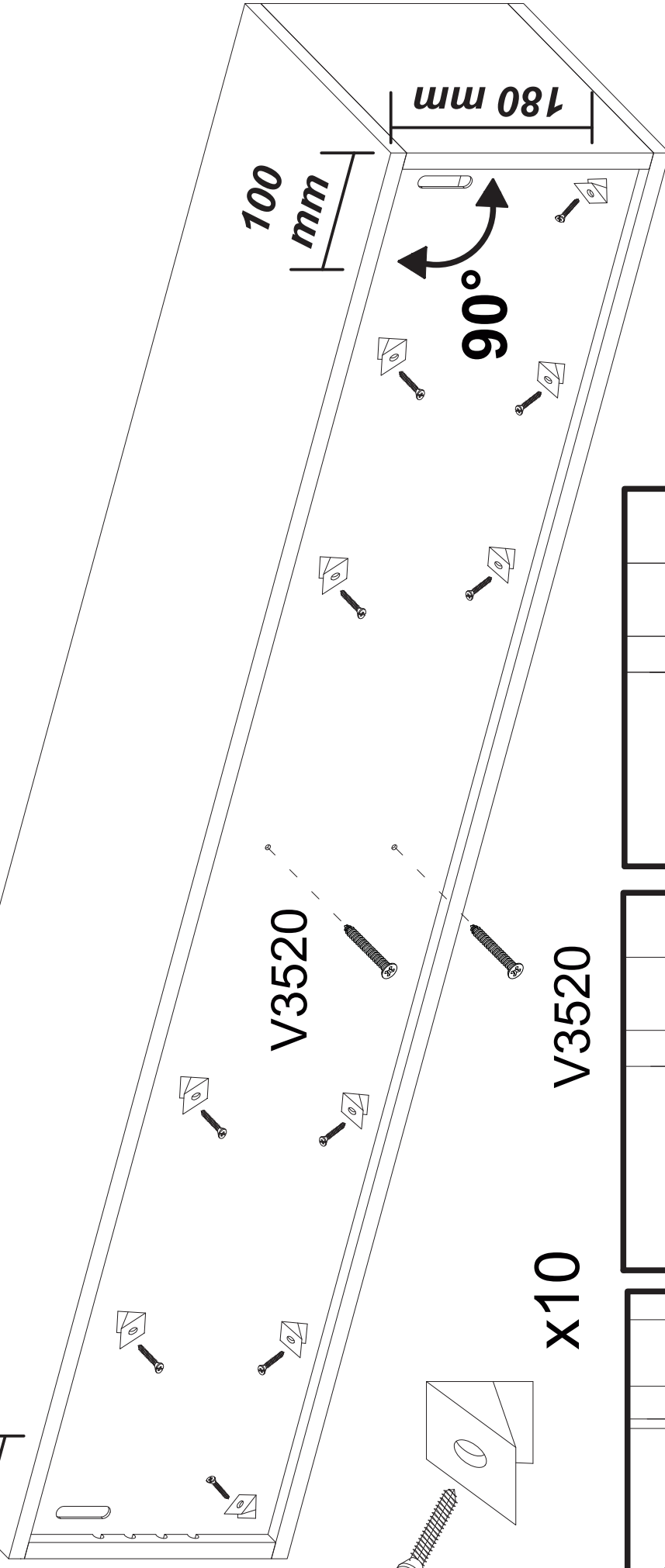

3

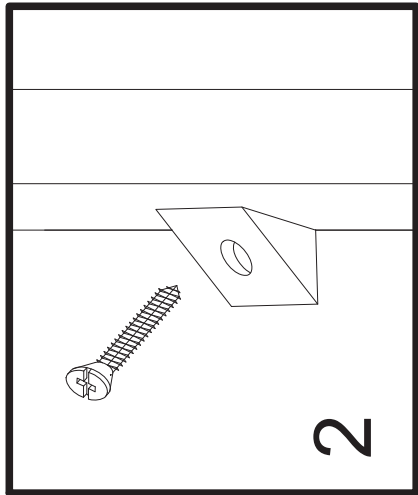

2

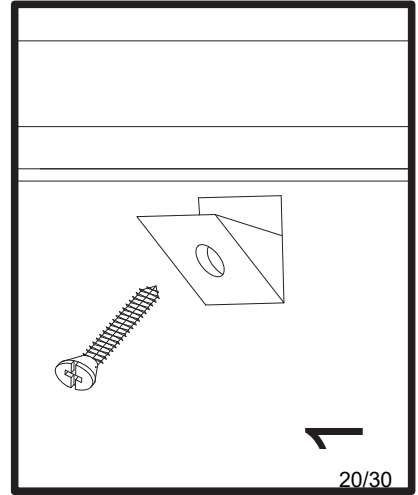

1

# 10

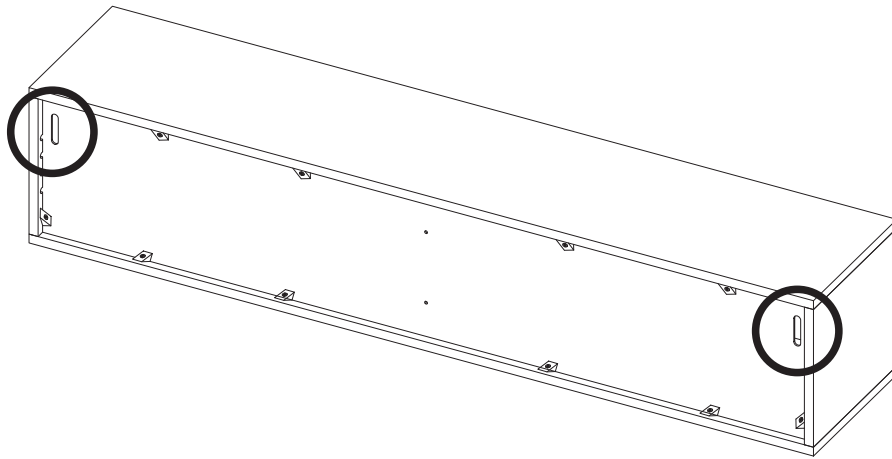

AT

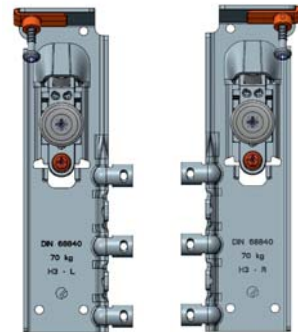

V3520

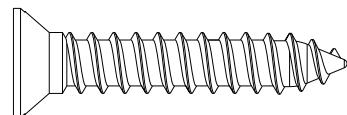

x4

# 2

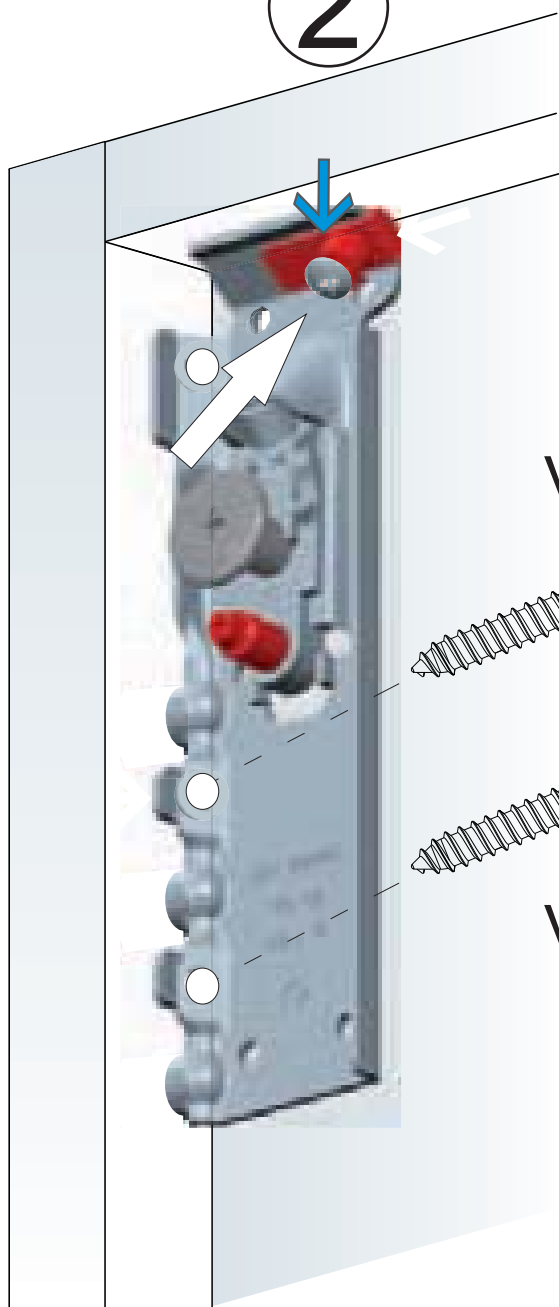
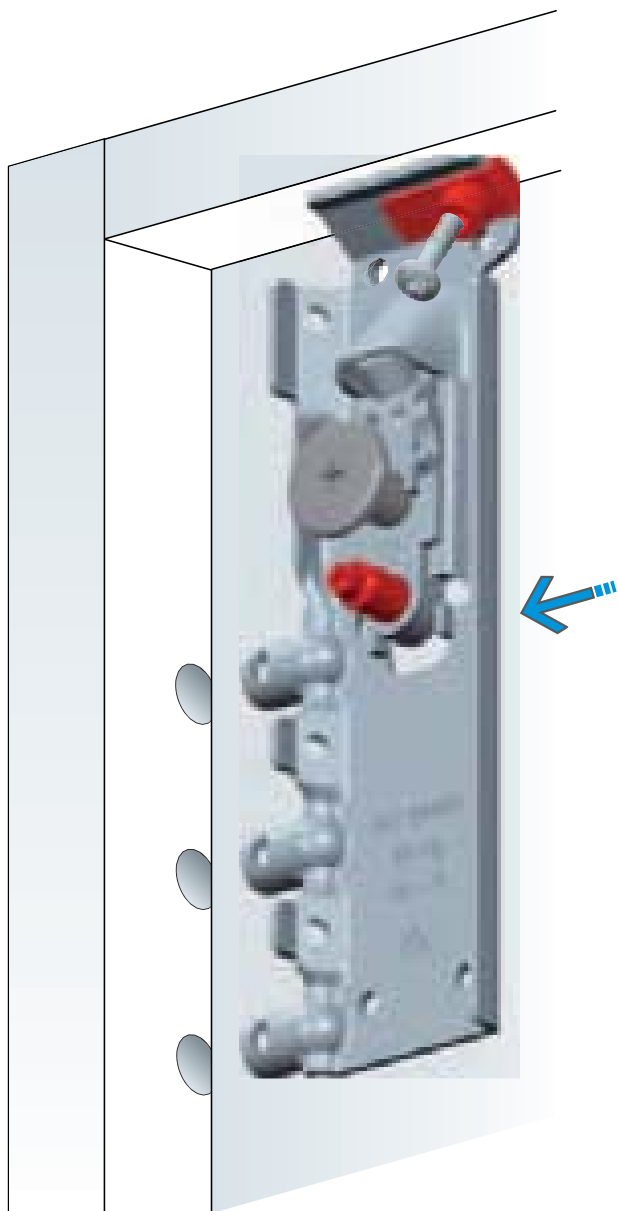

V3520

# 1

V3520





ST

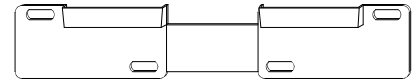

x1

32 36 1244 mm. 36 32

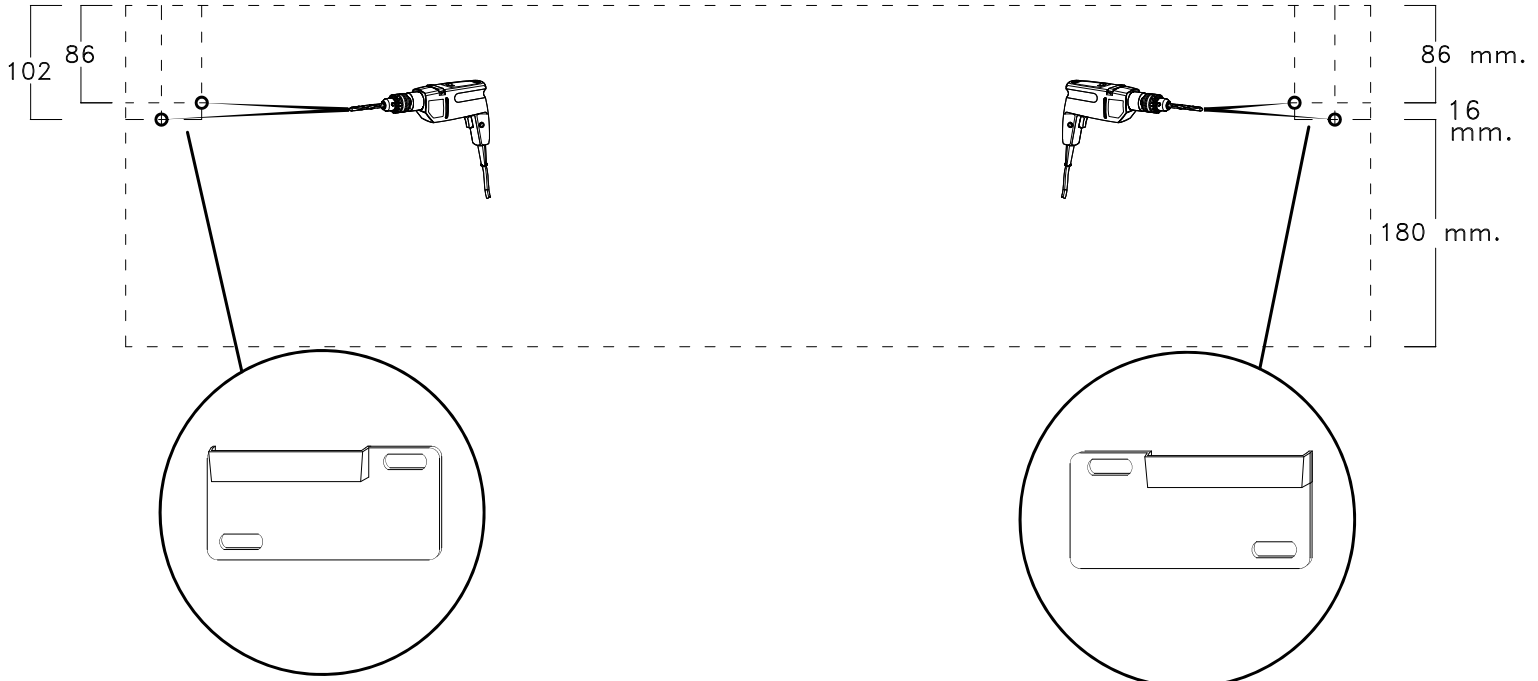

Gentile Cliente

Il montaggio dei pensili deve essere effettuato da personale competente. I tasselli di fissaggio non sono compresi nella ferramenta. Scegliere il tipo di tassello per il fissaggio più adatto alla tipologia di muro. Assicurarsi l'idoneità della parete per un sostegno sicuro del pensile.

Dear Customer,

The assembling of the hanging elements must be done by a competent staff. The wall plugs are not included in the hardware package. Choose the wall plugs more suitable to the type of the wall. Ensure the suitability of the wall for a secure support of the hanging element.

Sehr geehrter Kunde, die Montage der Hängeelemente muss von Fachpersonal ausgeführt werden!

Bitte verwenden Sie eigene Dübel, die der Beschaffenheit der Wand entsprechen. Zu Ihrer eigenen Sicherheit legen wir dem Beschlagbeutel keine Dübel bei.

Cher client, les éléments muraux ne peuvent être installés que par du personnel qualifié !

Veuillez utiliser vos propres ancrages adaptés à la nature du mur. Pour votre sécurité, nous n'incluons pas de chevilles dans le matériel.

Estimado cliente, el montaje de los muebles colgados en la pared debe ser realizado por personal competente. Los tacos de fijación no están incluidos en la bolsa de herrajes. Elija el tipo de anclaje de fijación que mejor se adapte al tipo de pared. Asegúrese de que la pared sea adecuada para un soporte seguro del mueble colgado en la pared.

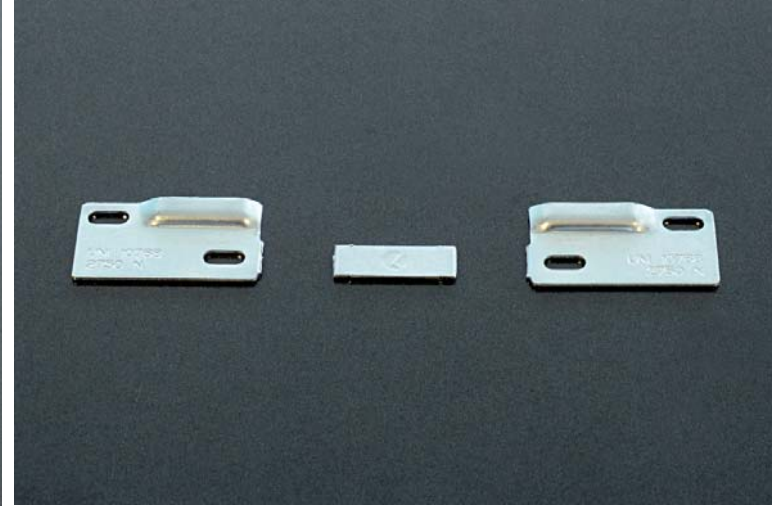
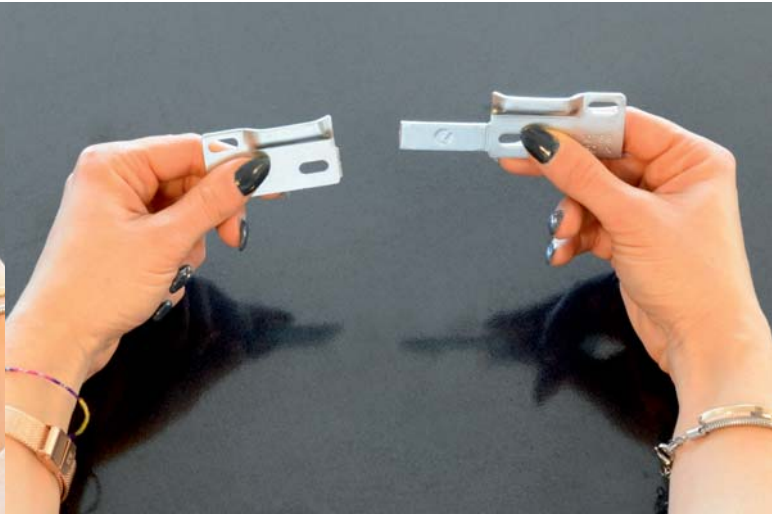
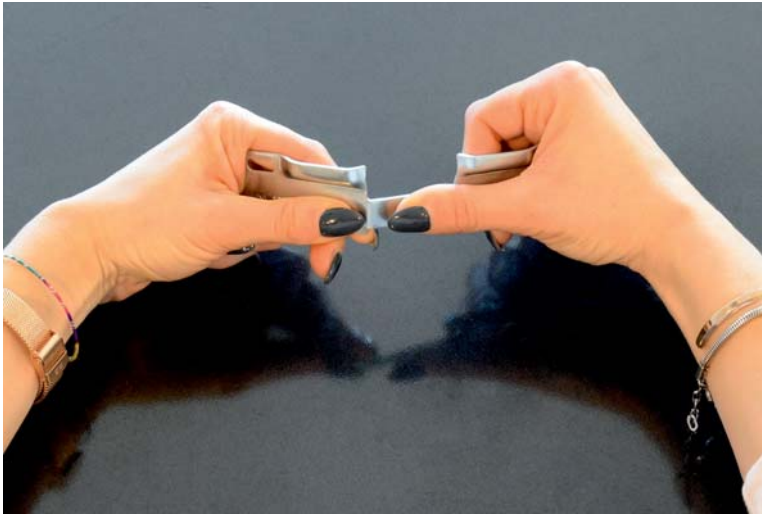
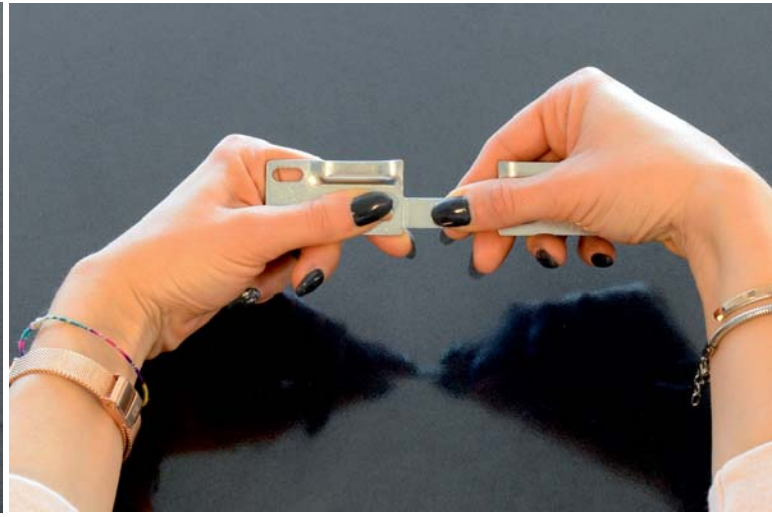
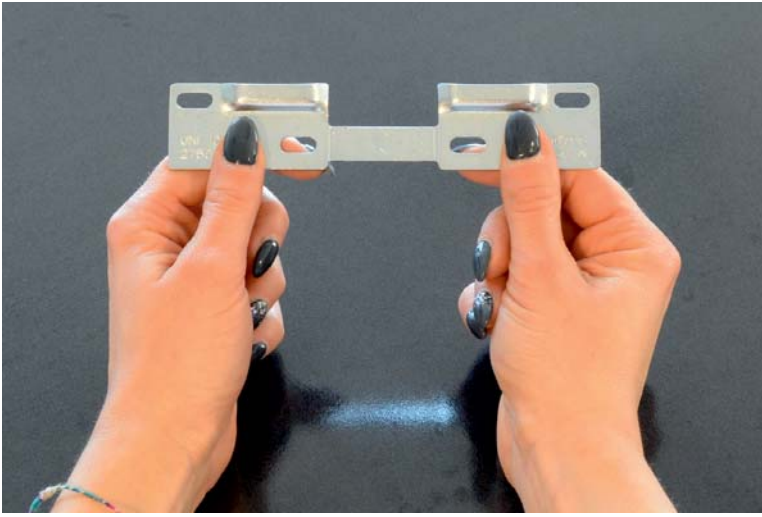

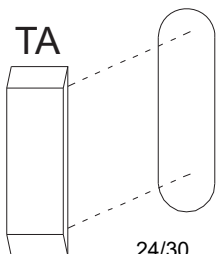
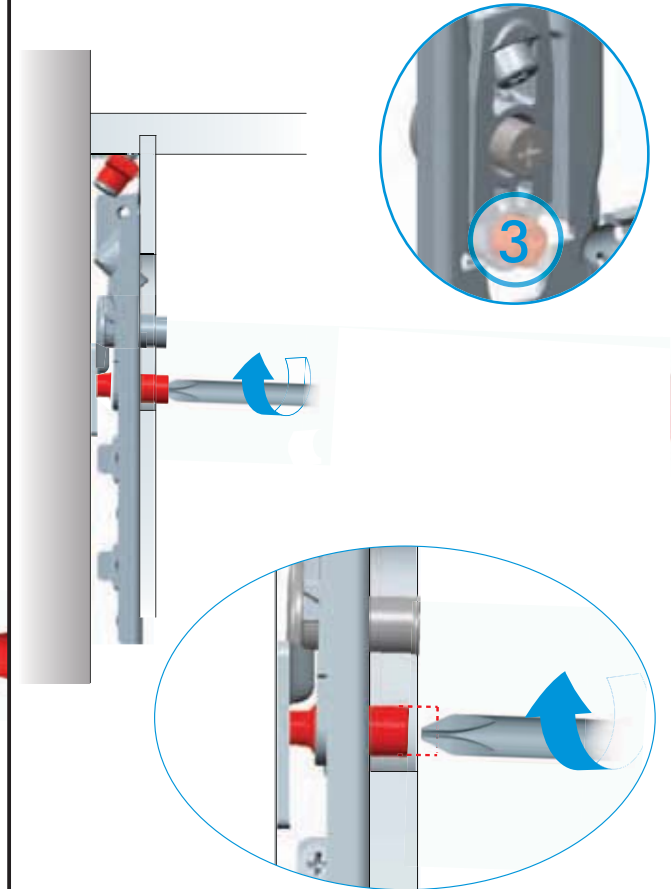
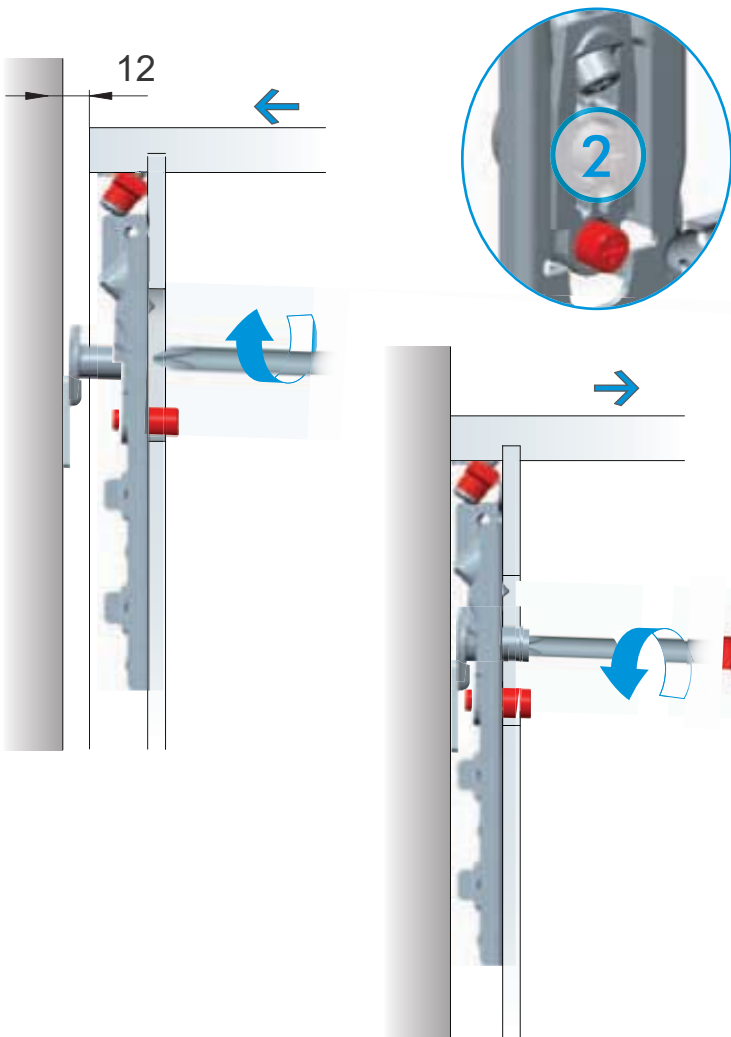
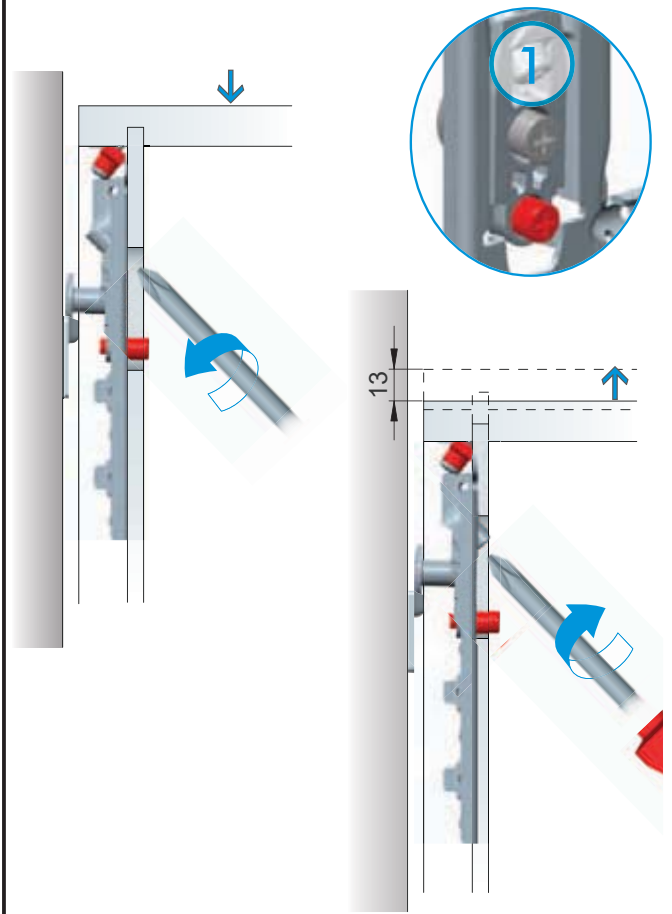
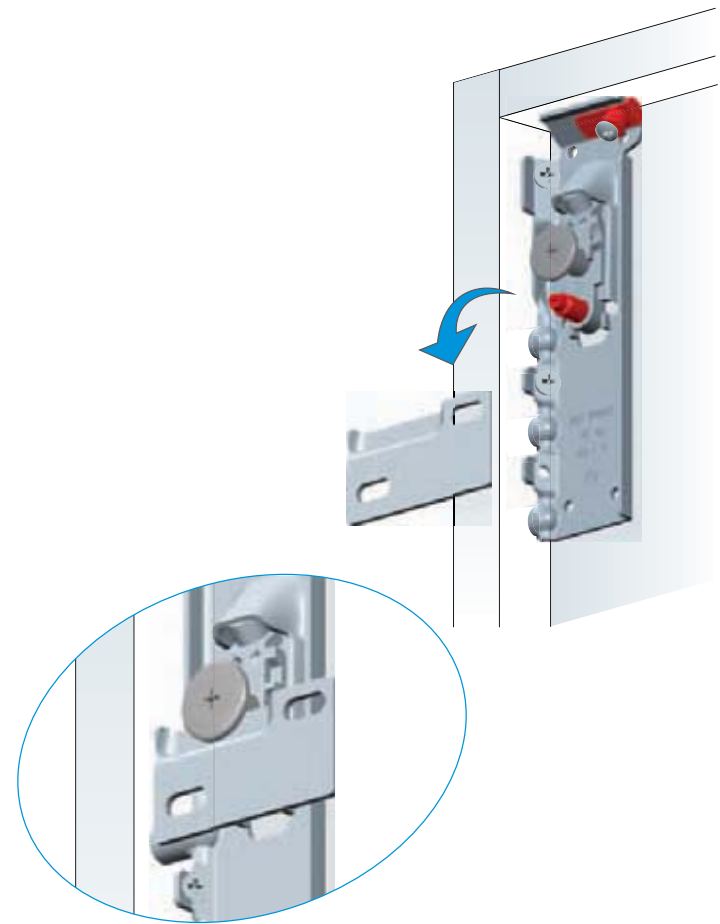

11

P

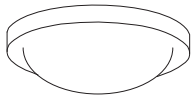

x2

C0

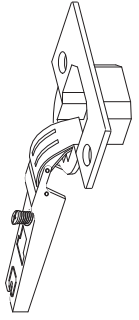

x3

V415

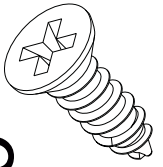

x6

Ø4x15 mm

V415 x2



C0

V415 x2

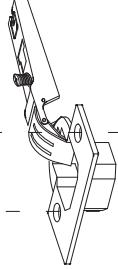

C0

V415 x2

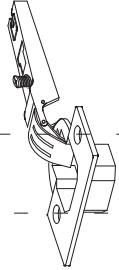

C0

P

P

18SP

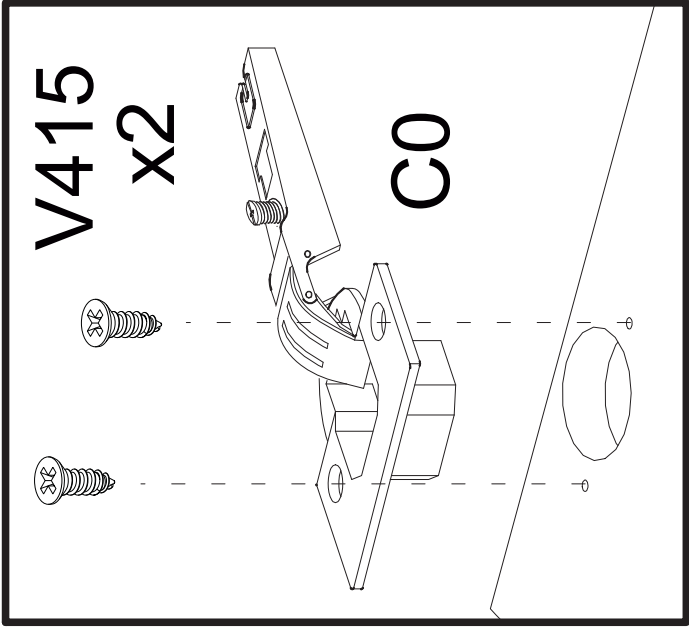

V415

x2

C0

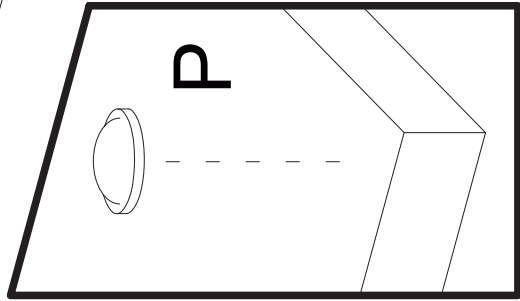

# 12

P18

x1

V316

x2

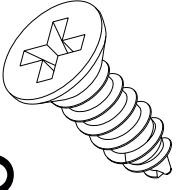
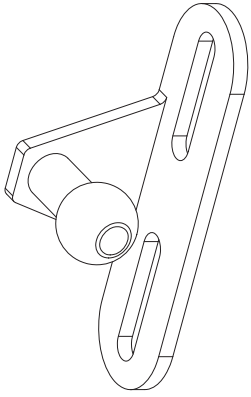

ø3x16 mm

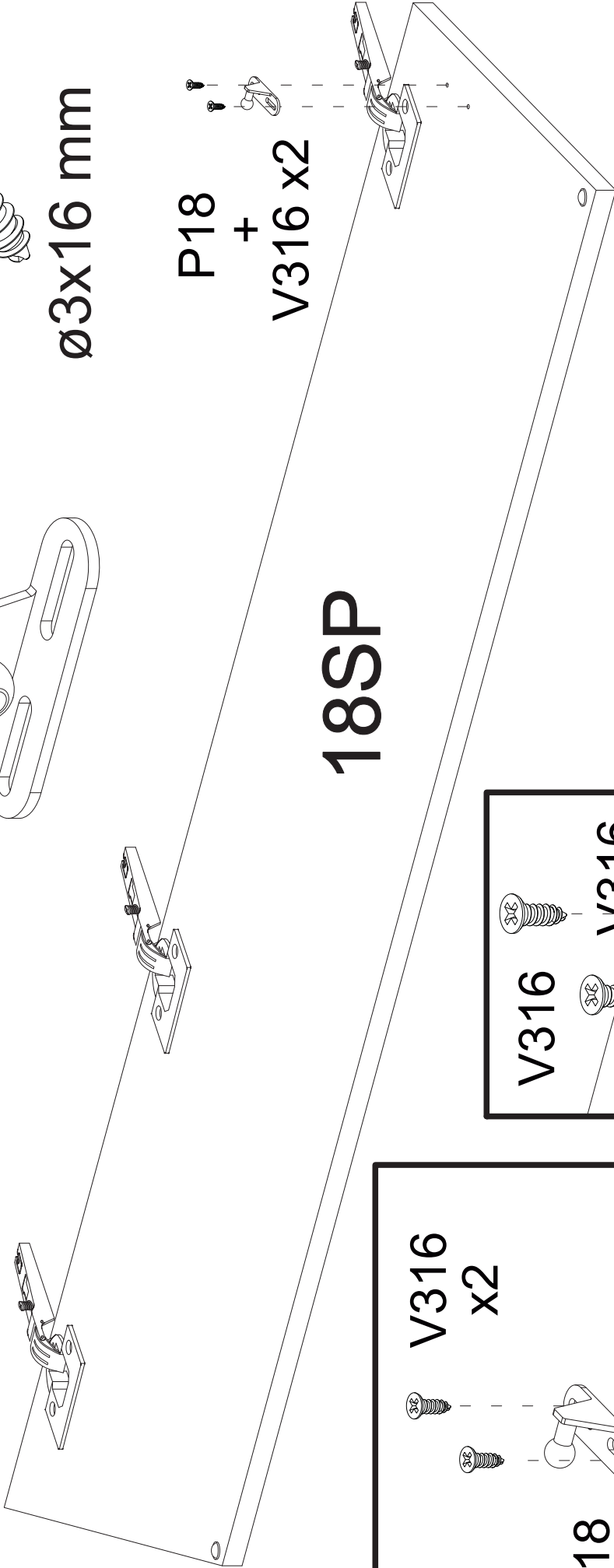

P18

+

V316 x2

## 18SP

V316

x2



P18

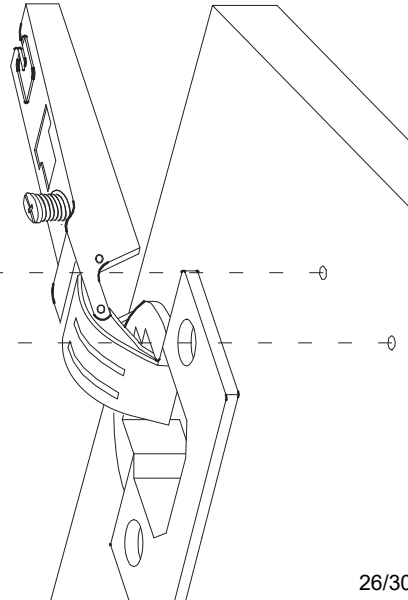
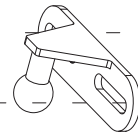

V316



V316

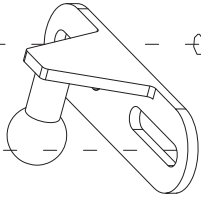

P18

P18

+

V316 x2

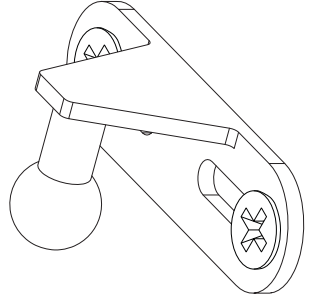



# 13

P19P

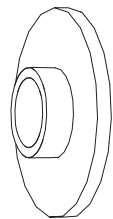

x1

T20

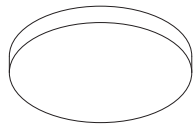

ø20

x5

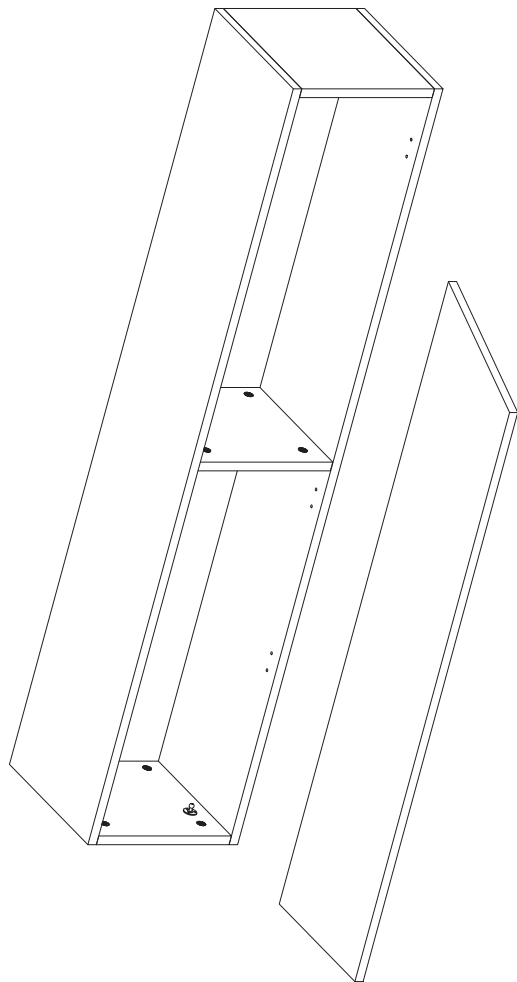
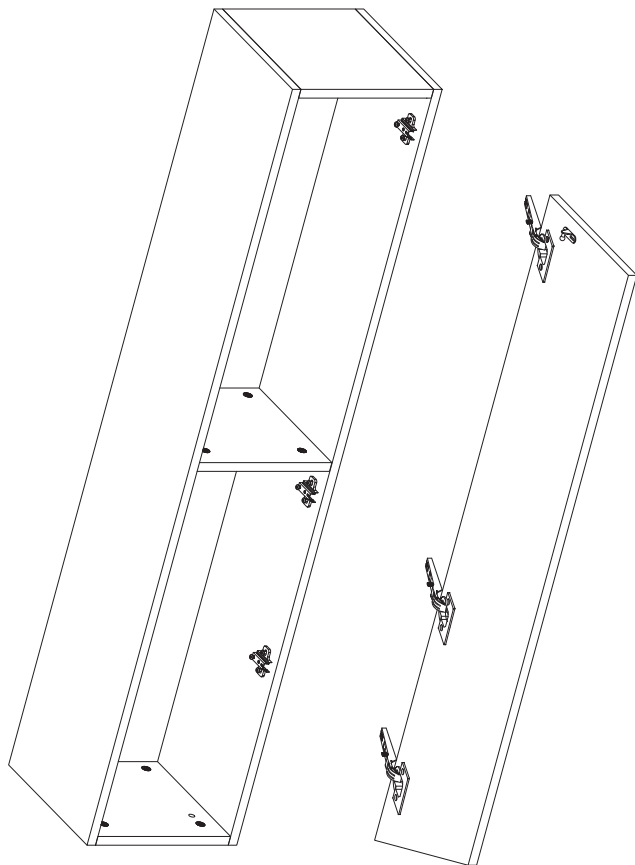

P19P

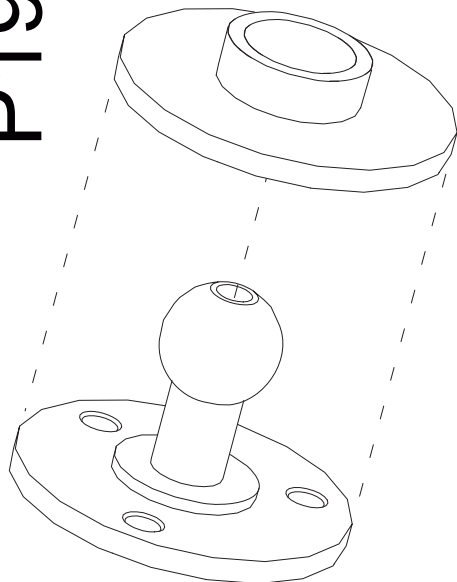

T20

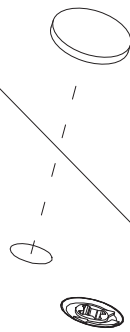

T20



14

K6

x1

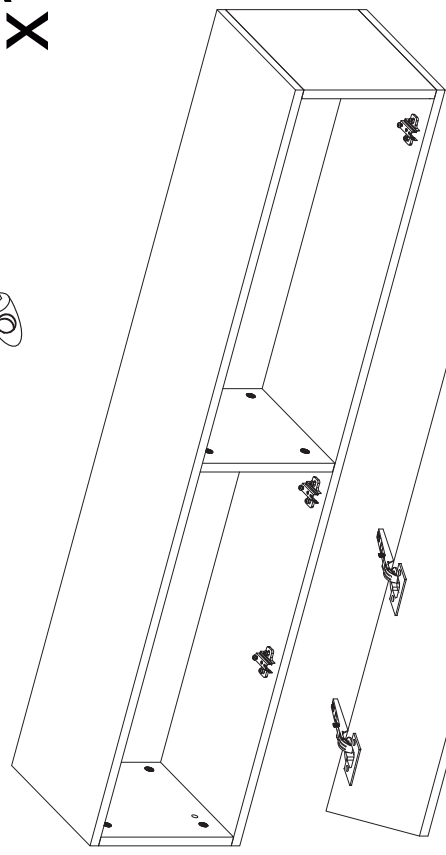
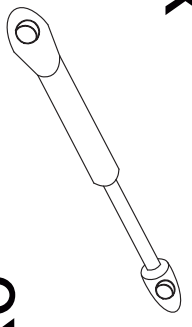

18SP



K6

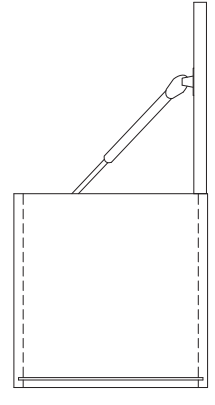
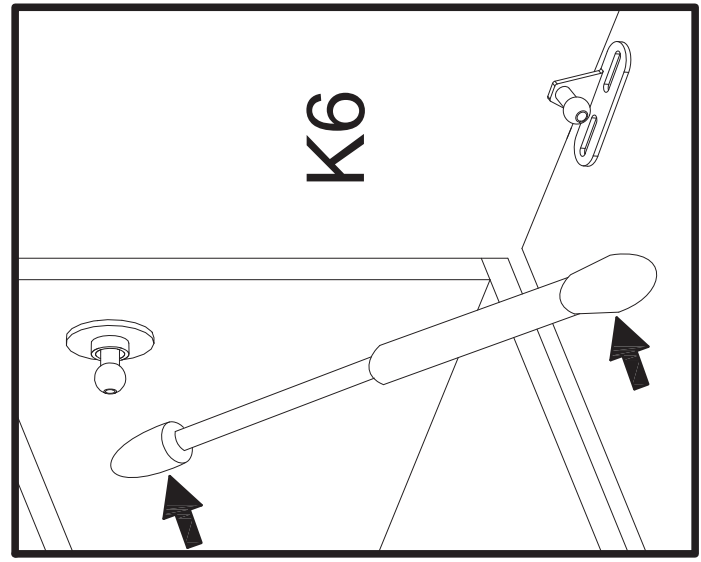

K11

x1

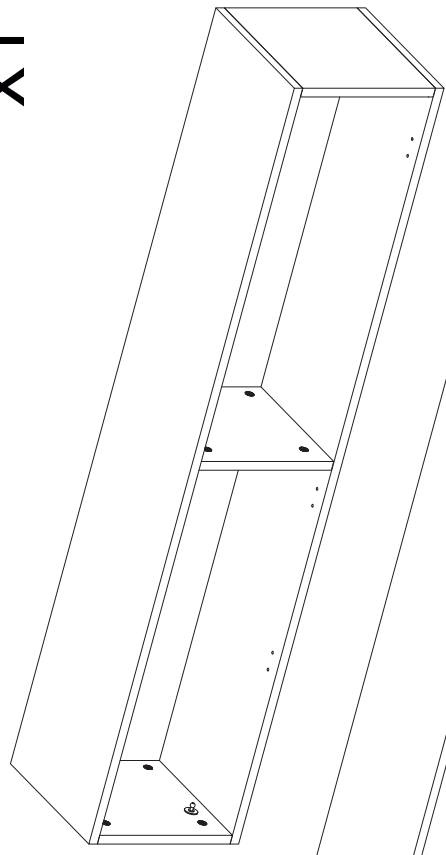
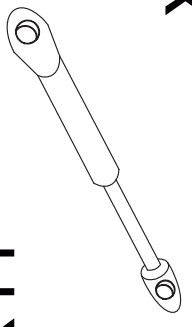

18SP

K11

