

SKU BC04801901WH/02MP

Naches

Naches

Assembly Instructions

Health Vatility Happiness



Naches

Health Vatility Happiness

✉ nachesoffical@gmail.com

CUSTOMER CARE



We're just happy cuz you're happy.
If you don't know how to express your new-found joy, we can get a few suggestions.

Tell your family and friends.
Share your experience by writing a review.

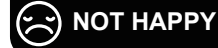

Our friendly customer service team will work hard to make you have a big smile.

Here's how to contact us.
✉ nachesoffical@gmail.com

Naches

(Parent Brand)

HedoAjim
(Sub-brand1)

Radelldar
(Sub-brand2)

Radelldar and HedoAjim are both sub brands of Naches

Naches

NOTICE:

- ▶ Basic precautions should always be followed when using this product. Please read all instructions before using the cabinet and retain the education for future reference.
- ▶ Failure to observe all instructions and warnings may cause severe property damage or personal injuries.
- ▶ When unpacking, please be careful don't cut too deep to damage the products in the box. Just use the blade to scratch the parcel tape.
- ▶ Check the product and hardware accessories in the box; and confirm whether the instructions are complete.
- ▶ When installing, please pay attention to the protection of the parts. The soft material must be placed under the product, and please carefully handle it to avoid surface damage.
- ▶ After the assembly is completed, please adjust the placement position according to the actual situation.
- ▶ Keep children away from cabinets, accessories, and installation tools. They are at risk of injury to the child.
- ▶ Two people are recommended for assembly.
- ▶ If you need the electronic manual, please contact our customer service to get it. (nachesoffical@gmail.com)

RETURN/DAMAGE CLAIM INSTRUCTIONS:

- ▶ Naches product is shipped in a single carton box. If you haven't received the package or need to know the tracking of the package, get in touch with us immediately via Amazon message or contact us via nachesoffical@gmail.com.
- ▶ If the package is damaged, please get in touch with us from the very beginning. Attaching a damaged photo is appreciated.
- ▶ Naches product accepts returns within 30 days without any reason. If you return this item for personal reasons, you must cover the return fee and order processing fee (0- 20% restocking fee based on the invoice price). We will cover the freight if the product has quality issues (not caused by humans).
- ▶ Please keep the original box if you need to return the goods. Please use our return label and do not return it without permission.
- ▶ If you return the product after 30 days of receiving it, we are afraid your return application won't be accepted. We appreciate your understanding.
- ▶ Any damages, defects and parts missings during installation, pls contact us from the very beginning. Replacement, exchange and refund will be arranged ASAP except of personal reasons.
- ▶ Customer Service: nachesoffical@gmail.com.

Part List



Open the package, and put the item on the mat with care. Please install it carefully to ensure your fingers will not be scratched.

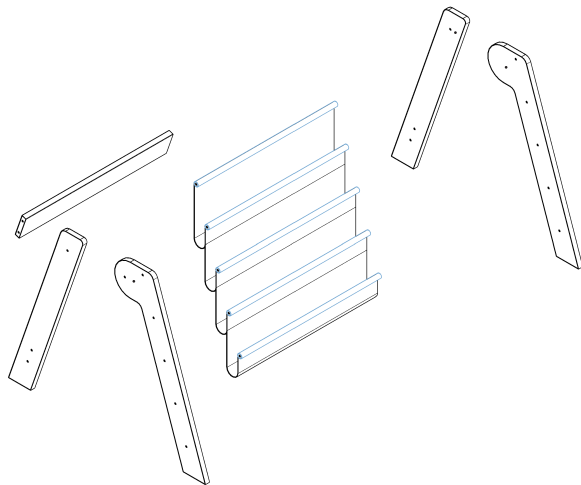
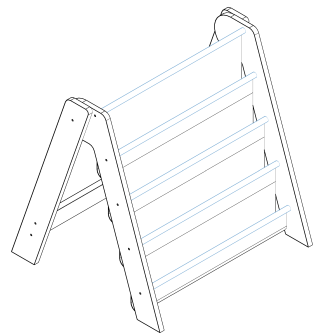

Hardware List

A

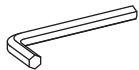

M3
x1

B



M5*35
x(14+2)

C

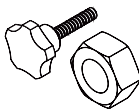

x2

D

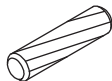

x2

Start...

I Step1

B



x5

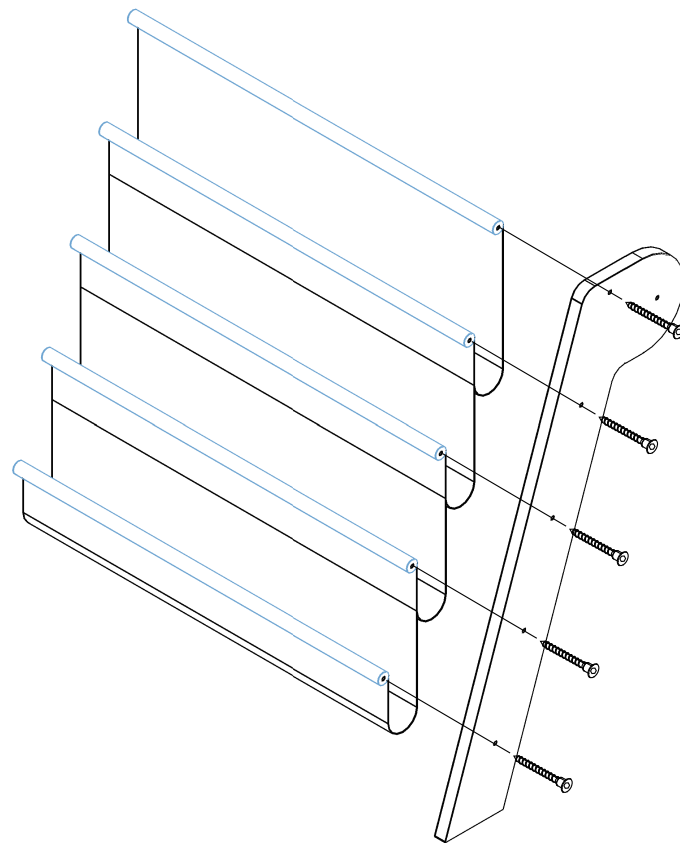

| Step2

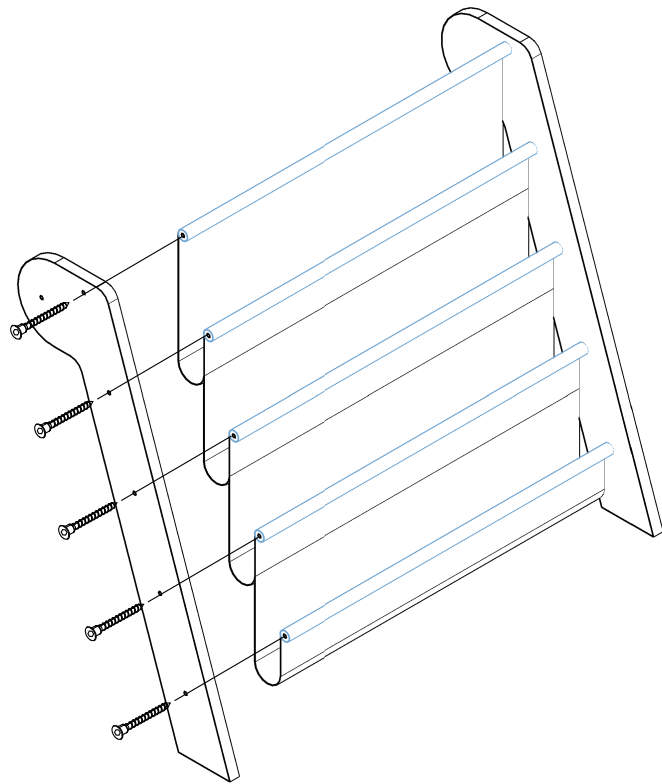
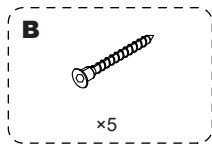

| Step3

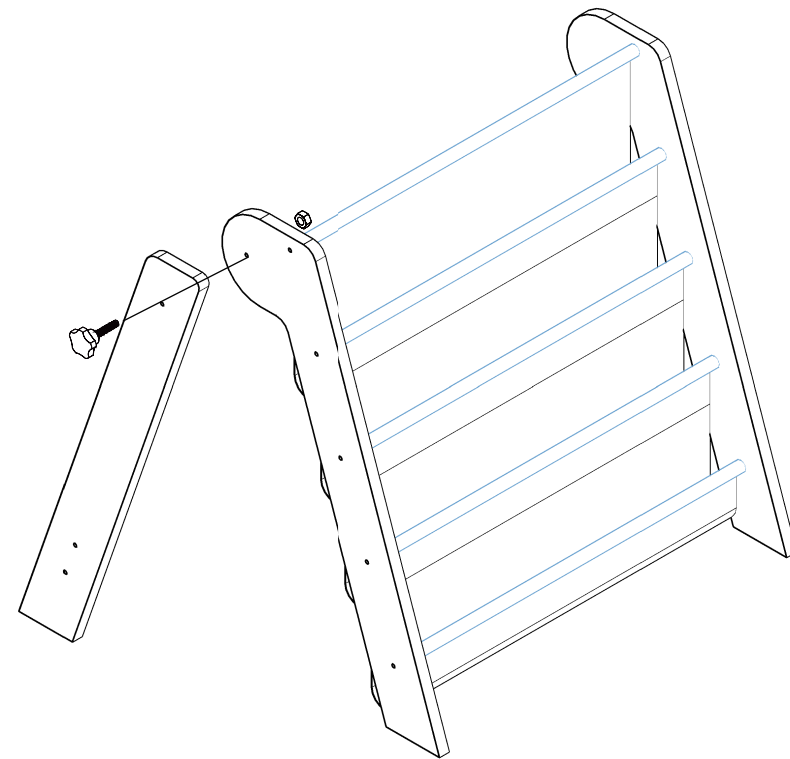
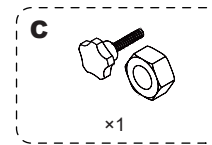

| Step4

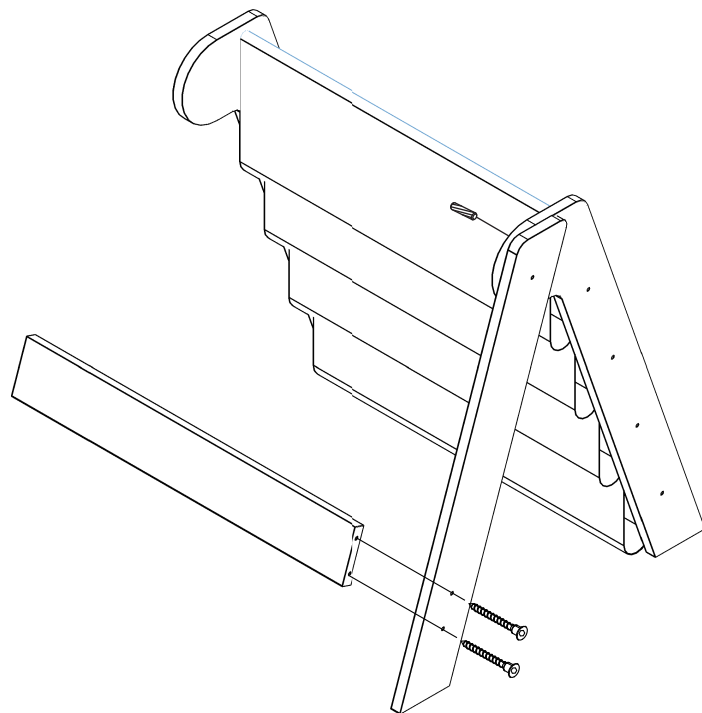
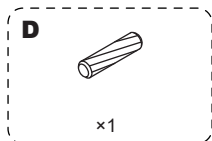
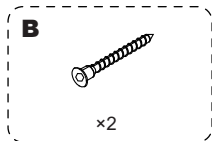

| Step5

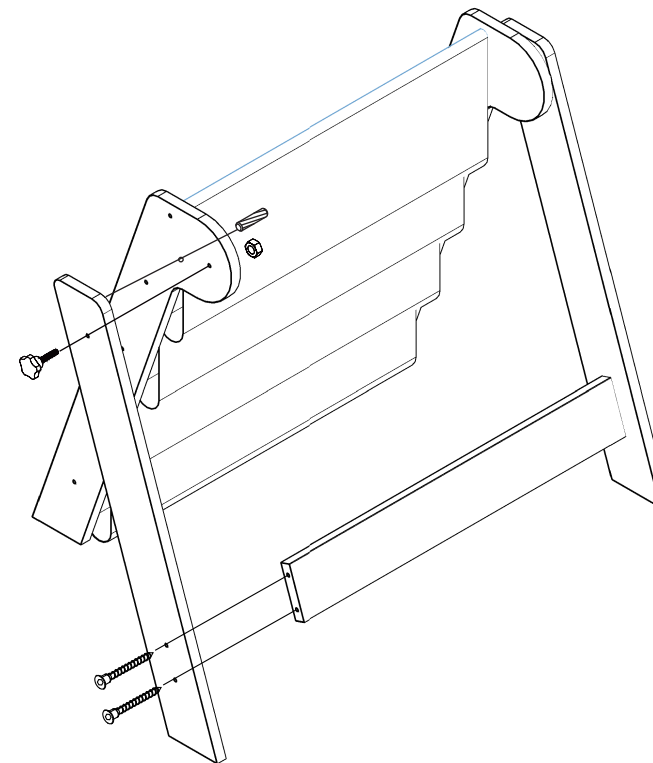
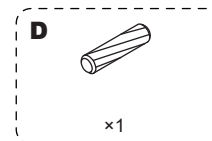
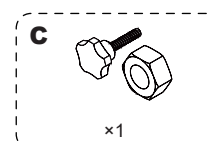
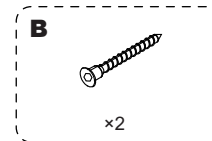

About Naches

Naches pursues health, vitality, happiness as the brand theme. Naches has devoted to design, research and develop children's furniture for many years to help you participate in children's unusual but wonderful thoughts. We do our best to use our each works to record every moment of kids and make home become beautiful amusement park.

Health Vitality Happiness

Customer Service: nachesofficial@gmail.com



LIMITED WARRANTY

Naches furniture team would like to improve customer service quality and make your experience smooth.

Return Policy: Naches accepts returns within 30 days without any significant reason. After we receive the returned item, we will check it and make sure that it is not damaged, then we will process the refund. For more details, please check the above terms of RETURN/DAMAGE CLAIM INSTRUCTIONS.

Any damages, defects and parts missings during installation, pls contact us from the very beginning. Replacement, exchange and refund will be arranged ASAP except of personal reasons.

The exceptions or exclusions to this warranty are as follows:

1. Naches does not accept claims outside of a limited period.
2. This warranty does not include the products purchased by mistake.
3. Any damages, broken parts, missing parts, Naches will repair or replace them without charging you any cost within a reasonable period.

We reserve the right to require damaged parts to be returned to us upon our request.

If you have any questions concerning this warranty, please get in touch with the Naches Customer Service department via Amazon message or nachesofficial@gmail.com. Be prepared to provide your name, address, daytime phone number, the product's model and purchase order number, the date of purchase, and the store name. All the information you provided will help us track your order quickly and solve your problem in the shortest time. This warranty gives you specific rights, and you still possess other rights that vary in each case.