

**D****Wichtige Pflegehinweise**

Bitte beachten Sie die wichtigen Pflegehinweise auf unserer Internetseite

www.till-hilft.de

Pflegehinweise

**PL****Ważne instrukcje dotyczące pielęgnacji**

Zwróć uwagę na ważną instrukcję dotyczącą pielęgnacji na naszej stronie internetowej

www.till-hilft.de

Pflegehinweise

**GB****Important care instructions**

Please note the important care instructions on our website

www.till-hilft.de

Pflegehinweise

**SK****Dôležité pokyny na starostlivosť**

Dbajte na dôležité pokyny týkajúce sa starostlivosti na našich webových stránkach

www.till-hilft.de

Pflegehinweise

**FR****Instructions d'entretien importantes**

S'il vous plaît noter les instructions de soins importants sur notre site Web

www.till-hilft.de

Pflegehinweise

**HU****Fontos kezelési utasítások**

Kérjük, vegye figyelembe a honlapunkon található fontos kezelési útmutatót

www.till-hilft.de

Pflegehinweise

**IT****Importanti istruzioni per la cura**

Si prega di notare le importanti istruzioni per la cura sul nostro sito web

www.till-hilft.de

Pflegehinweise

**RO****Instrucțiunile importante de îngrijire**

Rețineți instrucțiunile importante de îngrijire de pe site-ul nostru

www.till-hilft.de

Pflegehinweise

**NL****Belangrijke zorginstructies**

Let op de belangrijke zorginstructies op onze website

www.till-hilft.de

Pflegehinweise

**TR****Önemli bakım talimatları**

Lütfen web sitemizdeki önemli bakım talimatlarını dikkate alınız

www.till-hilft.de

Pflegehinweise

**CZ****Důležité pokyny pro péči**

Vezměte prosím na vědomí důležité pokyny pro péči na našich webových stránkách

www.till-hilft.de

Pflegehinweise

**RU****Важные инструкции по уходу**

Обратите внимание на важные инструкции по уходу на нашем веб-сайте

www.till-hilft.de

Pflegehinweise



**D****Wichtige Pflegehinweise**

Bitte beachten Sie die wichtigen Pflegehinweise auf unserer Internetseite

www.till-hilft.de

Pflegehinweise

**PL****Ważne instrukcje dotyczące pielęgnacji**

Zwróć uwagę na ważną instrukcję dotyczącą pielęgnacji na naszej stronie internetowej

www.till-hilft.de

Pflegehinweise

**GB****Important care instructions**

Please note the important care instructions on our website

www.till-hilft.de

Pflegehinweise

**SK****Dôležité pokyny na starostlivosť**

Dbajte na dôležité pokyny týkajúce sa starostlivosti na našich webových stránkach

www.till-hilft.de

Pflegehinweise

**FR****Instructions d'entretien importantes**

S'il vous plaît noter les instructions de soins importants sur notre site Web

www.till-hilft.de

Pflegehinweise

**HU****Fontos kezelési utasítások**

Kérjük, vegye figyelembe a honlapunkon található fontos kezelési útmutatót

www.till-hilft.de

Pflegehinweise

**IT****Importanti istruzioni per la cura**

Si prega di notare le importanti istruzioni per la cura sul nostro sito web

www.till-hilft.de

Pflegehinweise

**RO****Instrucțiunile importante de îngrijire**

Rețineți instrucțiunile importante de îngrijire de pe site-ul nostru

www.till-hilft.de

Pflegehinweise

**NL****Belangrijke zorginstructies**

Let op de belangrijke zorginstructies op onze website

www.till-hilft.de

Pflegehinweise

**TR****Önemli bakım talimatları**

Lütfen web sitemizdeki önemli bakım talimatlarını dikkate alınız

www.till-hilft.de

Pflegehinweise

**CZ****Důležité pokyny pro péči**

Vezměte prosím na vědomí důležité pokyny pro péči na našich webových stránkách

www.till-hilft.de

Pflegehinweise

**RU****Важные инструкции по уходу**

Обратите внимание на важные инструкции по уходу на нашем веб-сайте

www.till-hilft.de

Pflegehinweise



**D****Wichtige Pflegehinweise**

Bitte beachten Sie die wichtigen Pflegehinweise auf unserer Internetseite



www.till-hilft.de



Pflegehinweise

**PL****Ważne instrukcje dotyczące pielęgnacji**

Zwróć uwagę na ważną instrukcję dotyczącą pielęgnacji na naszej stronie internetowej



www.till-hilft.de



Pflegehinweise

**GB****Important care instructions**

Please note the important care instructions on our website



www.till-hilft.de



Pflegehinweise

**SK****Dôležité pokyny na starostlivosť**

Dbajte na dôležité pokyny týkajúce sa starostlivosti na našich webových stránkach



www.till-hilft.de



Pflegehinweise

**FR****Instructions d'entretien importantes**

S'il vous plaît noter les instructions de soins importants sur notre site Web



www.till-hilft.de



Pflegehinweise

**HU****Fontos kezelési utasítások**

Kérjük, vegye figyelembe a honlapunkon található fontos kezelési útmutatót



www.till-hilft.de



Pflegehinweise

**IT****Importanti istruzioni per la cura**

Si prega di notare le importanti istruzioni per la cura sul nostro sito web



www.till-hilft.de



Pflegehinweise

**RO****Instrucțiunile importante de îngrijire**

Rețineți instrucțiunile importante de îngrijire de pe site-ul nostru



www.till-hilft.de



Pflegehinweise

**NL****Belangrijke zorginstructies**

Let op de belangrijke zorginstructies op onze website



www.till-hilft.de



Pflegehinweise

**TR****Önemli bakım talimatları**

Lütfen web sitemizdeki önemli bakım talimatlarını dikkate alınız



www.till-hilft.de



Pflegehinweise

**CZ****Důležité pokyny pro péči**

Vezměte prosím na vědomí důležité pokyny pro péči na našich webových stránkách



www.till-hilft.de



Pflegehinweise

**RU****Важные инструкции по уходу**

Обратите внимание на важные инструкции по уходу на нашем веб-сайте



www.till-hilft.de



Pflegehinweise



**D****Wichtige Pflegehinweise**

Bitte beachten Sie die wichtigen Pflegehinweise auf unserer Internetseite



www.till-hilft.de



Pflegehinweise

**PL****Ważne instrukcje dotyczące pielęgnacji**

Zwróć uwagę na ważną instrukcję dotyczącą pielęgnacji na naszej stronie internetowej



www.till-hilft.de



Pflegehinweise

**GB****Important care instructions**

Please note the important care instructions on our website



www.till-hilft.de



Pflegehinweise

**SK****Dôležité pokyny na starostlivosť**

Dbajte na dôležité pokyny týkajúce sa starostlivosti na našich webových stránkach



www.till-hilft.de



Pflegehinweise

**FR****Instructions d'entretien importantes**

S'il vous plaît noter les instructions de soins importants sur notre site Web



www.till-hilft.de



Pflegehinweise

**HU****Fontos kezelési utasítások**

Kérjük, vegye figyelembe a honlapunkon található fontos kezelési útmutatót



www.till-hilft.de



Pflegehinweise

**IT****Importanti istruzioni per la cura**

Si prega di notare le importanti istruzioni per la cura sul nostro sito web



www.till-hilft.de



Pflegehinweise

**RO****Instrucțiunile importante de îngrijire**

Rețineți instrucțiunile importante de îngrijire de pe site-ul nostru



www.till-hilft.de



Pflegehinweise

**NL****Belangrijke zorginstructies**

Let op de belangrijke zorginstructies op onze website



www.till-hilft.de



Pflegehinweise

**TR****Önemli bakım talimatları**

Lütfen web sitemizdeki önemli bakım talimatlarını dikkate alınız



www.till-hilft.de



Pflegehinweise

**CZ****Důležité pokyny pro péči**

Vezměte prosím na vědomí důležité pokyny pro péči na našich webových stránkách



www.till-hilft.de



Pflegehinweise

**RU****Важные инструкции по уходу**

Обратите внимание на важные инструкции по уходу на нашем веб-сайте



www.till-hilft.de



Pflegehinweise





1 4 x 2827	2 4 x	3 2 x 1503	4 2 x 1611	5 3,5 x 15 4 x 2804	6 8 x 30 20 x 2861
7 6,3 x 11 4 x 2815	8 5/5 x 16 4 x 2821	9 5mm 2 x 2855	10 M4 x 9 2 x 2835	11 2 x	12 4 x
13 2 x 5265	14 4 x 9 2 x	15 5 x 30 1 x	16 25 x 2862	17 Leim 1 x 2863	18 3,5 x 30 4 x 2807
A 4 x 1980	B 3,5 x 15 16 x 2804	C 8mm 4 x 2917			

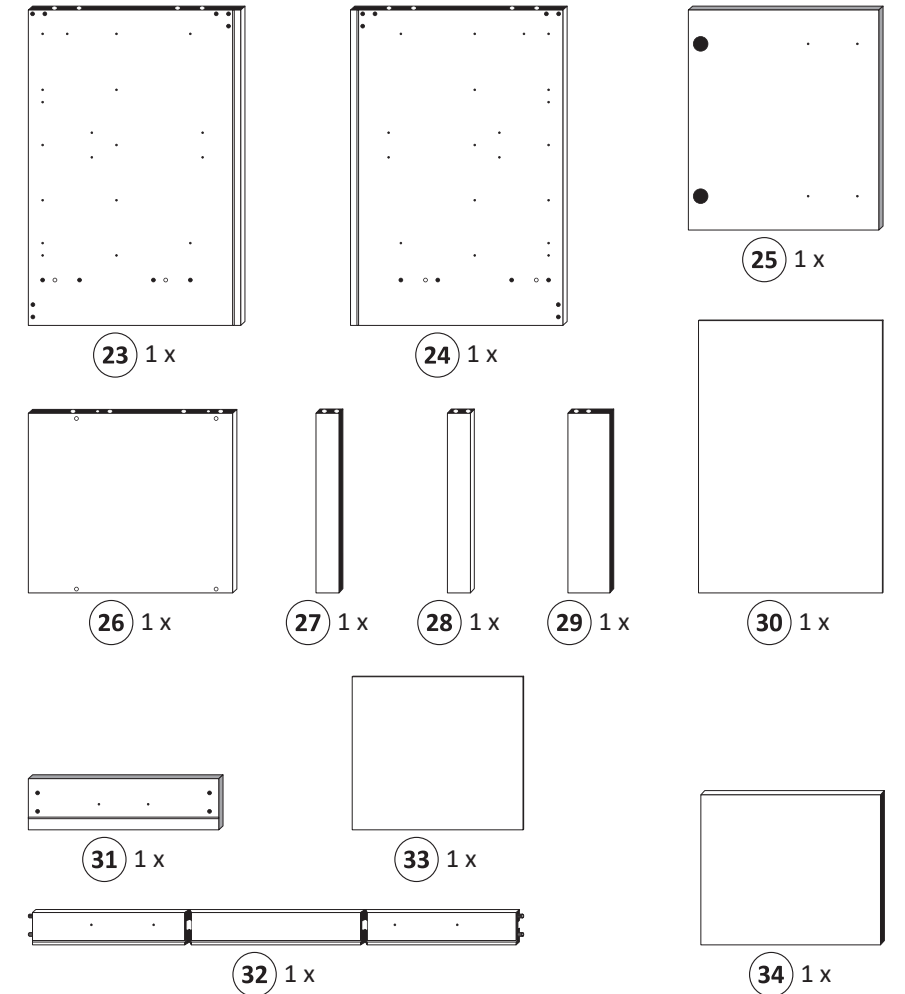
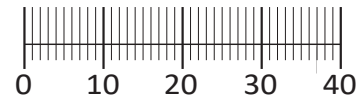

87112.511

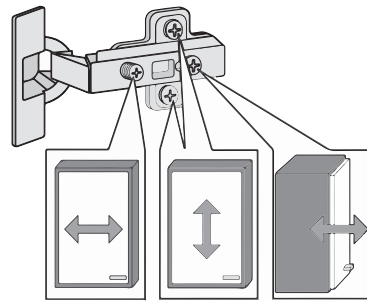
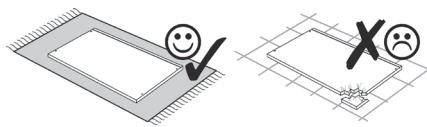
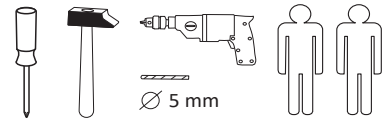

Das beigegefügte Wandbefestigungsmaterial (Dübel und Schrauben) eignet sich nur für festes Mauerwerk (z.B. Beton- oder Ziegelwände). Für andere Wandaufbauten sind eventuell Spezialdübel und andere Schrauben notwendig. Ziehen Sie gegebenenfalls eine Fachkraft zu Rate.

De begeleidende wandmontage hardware (pluggen en schroeven) is alleen geschikt voor massief metselwerk (bijvoorbeeld beton of bakstenen muren). Voor andere muur structuren zijn eventueel bijzondere ankerbouten en andere noodzakelijke. Draai indien nodig, een deskundige.

Приложенный материал для крепления к стене (дюбели и винты) пригоден только для жестких кладок (например, бетонные или кирпичные стены). Для других настенных конструкций необходимы смотря по обстоятельствам специальные дюбели и другие винты. При необходимости проконсультируйтесь у специалиста.

Le mur d'accompagnement matériel de montage (chevilles et les vis) ne convient que pour la maçonnerie solide (par exemple en béton ou des murs de briques). Pour les structures de mur d'autres sont peut-être spéciale boulons d'ancrage et d'autres nécessaires. Serrer le cas échéant, un expert.

Załączony materiał do mocowania do ściany (kolki rozprężne i wkręty) nadaje się tylko do ścian murowanych (np. z betonu lub cegieł). Do ścian wykonanych w innych technologiach konieczne być mogą specjalne kolki rozprężne i inne wkręty. W razie potrzeby skorzystaj z fachowej pomocy

Il muro di accompagnamento hardware di montaggio (tasselli e viti) è adatto solo per muratura piena (ad esempio calcestruzzo o muratura). Per le altre strutture murarie sono forse speciali bulloni di ancoraggio e necessari di altri. Serrare se necessario, un esperto.

The accompanying wall mounting hardware (anchors and screws) is suitable only for solid masonry (eg concrete or brick walls). For other wall structures are possibly special anchor bolts and other necessary. Tighten if necessary, an expert.

Ekteki duvara sabit montaj malzemeleri (dübel ve vidalar), sadece sağlam duvarlar için (örnek: beton veya tuğla) elverişlidir. Başka duvarlar için özel dübeller ve farklı vidalar gerekebilir. Gerektiğinde bir uzmana danışınız.

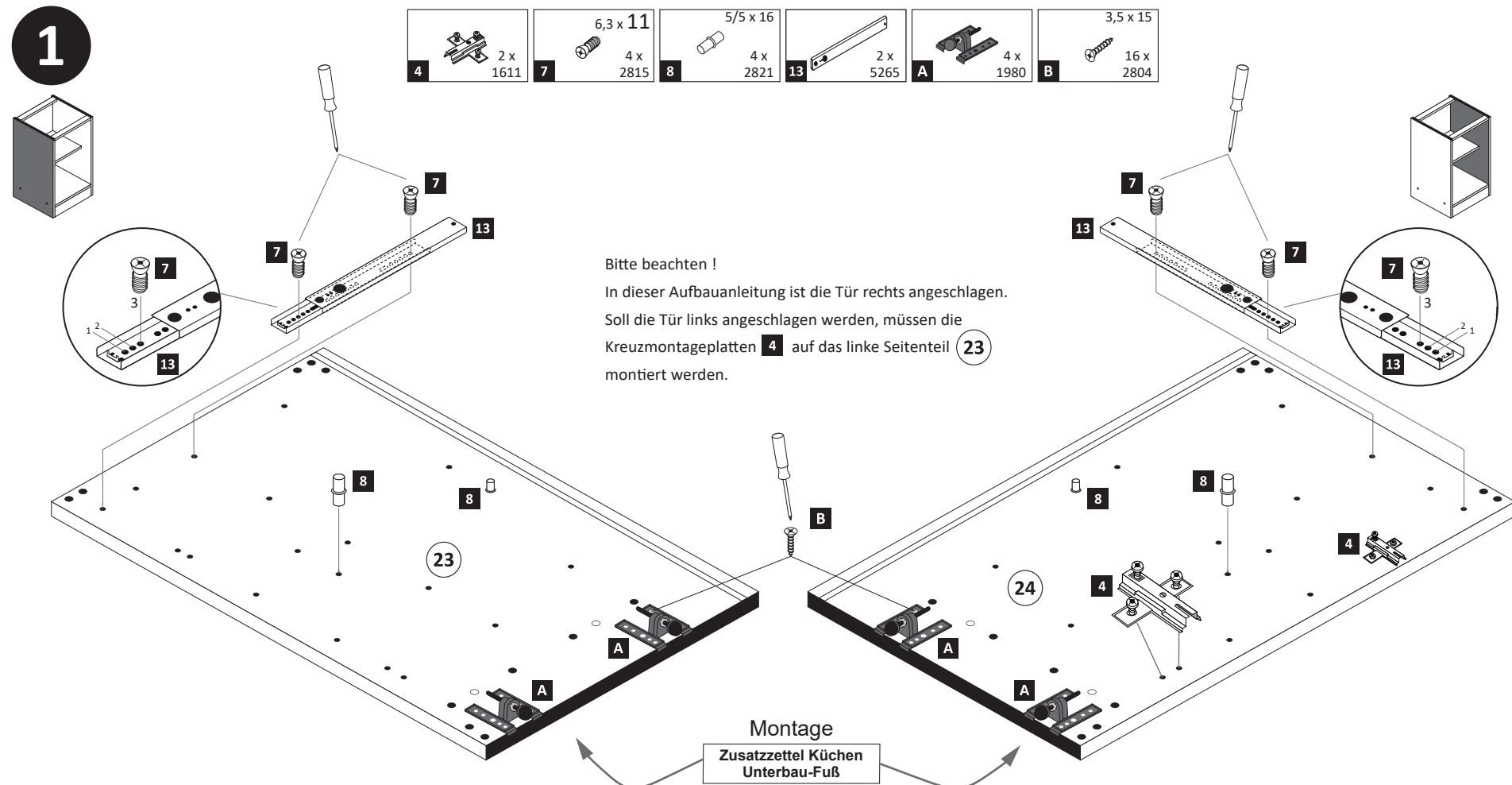

Bitte beachten!
In dieser Aufbauanleitung ist die Tür rechts angeschlagen.
Soll die Tür links angeschlagen werden, müssen die Kreuzmontageplatten **4** auf das linke Seitenteil **23** montiert werden.

Montage
Zusatzzettel Küchen
Unterbau-Fuß

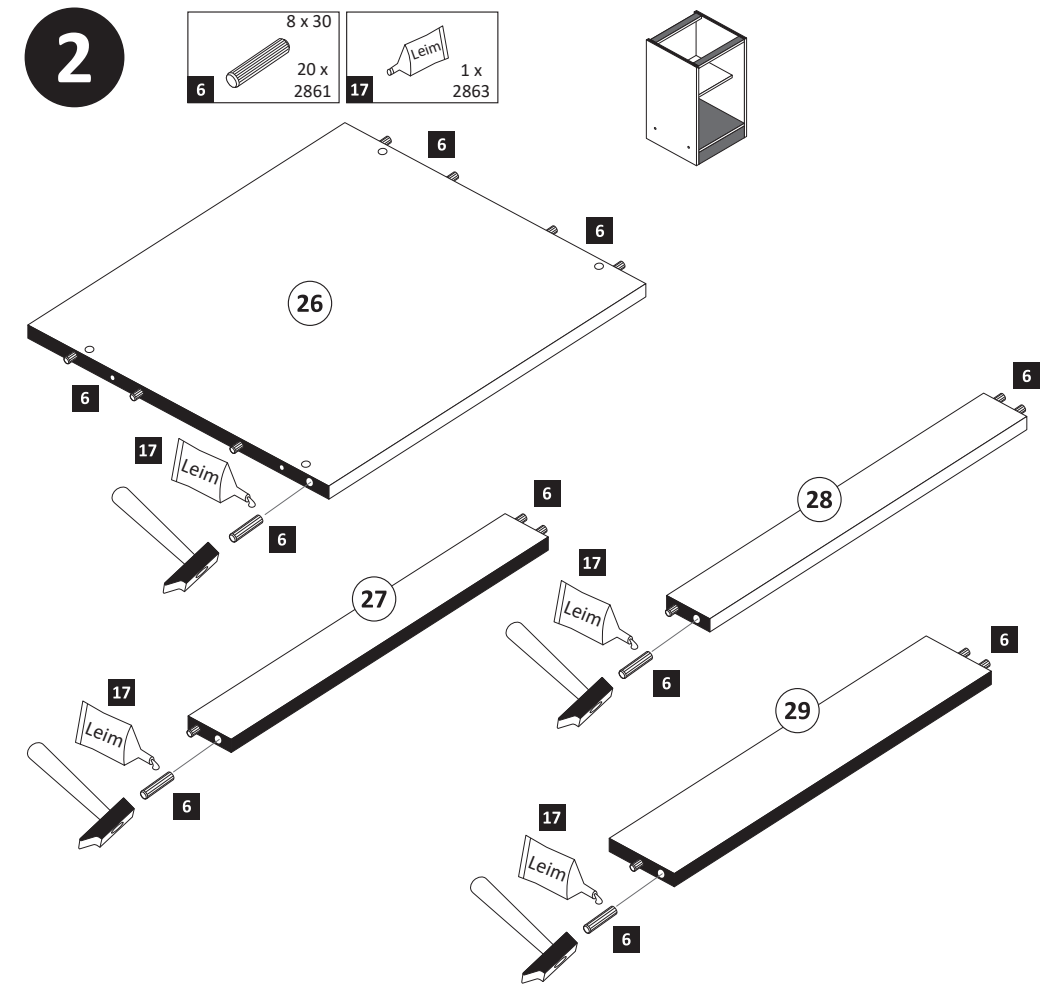

4

1 4 x 2827 2 4 x

17 1 x 2863

Leim

20 min.

D Leim
GB Glue
NL Lijm
PL Klej
TR Tutkal
F Colle
I Colla

5

15 25 x 2862

6

11 1 x 12 2 x 16 2 x 2865 17 1 x 2863

1. 2. 3.

7

M4 x 9 10 2 x 2835

8

3 2 x 1503 5 3,5 x 15 4 x 2804 16 2 x 2865

1. 2.

9

9 5mm 2 x 2855 11 1 x 12 2 x

10

14 4 x 9 2 x 5 x 30 1 x

a b

! Tipp!
Versiegeln Sie die Küche wie abgebildet gegen eventuell eindringende Feuchtigkeit. (Silikon nicht im Lieferumfang enthalten)

www.till-hilft.de



89930.330

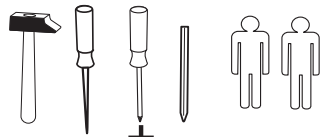
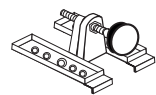

4 x A 1980	3,5 x 15 16 x B 2804	8mm 4 x C 2917
---------------	----------------------------	----------------------

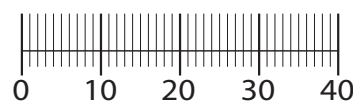

!! WICHTIG!!

Bitte fixieren den Schrank an der Wand bzw. an dem Nachbarschrank erst nach dem die Höheneinstellung mit dem Füßen durchgeführt ist.

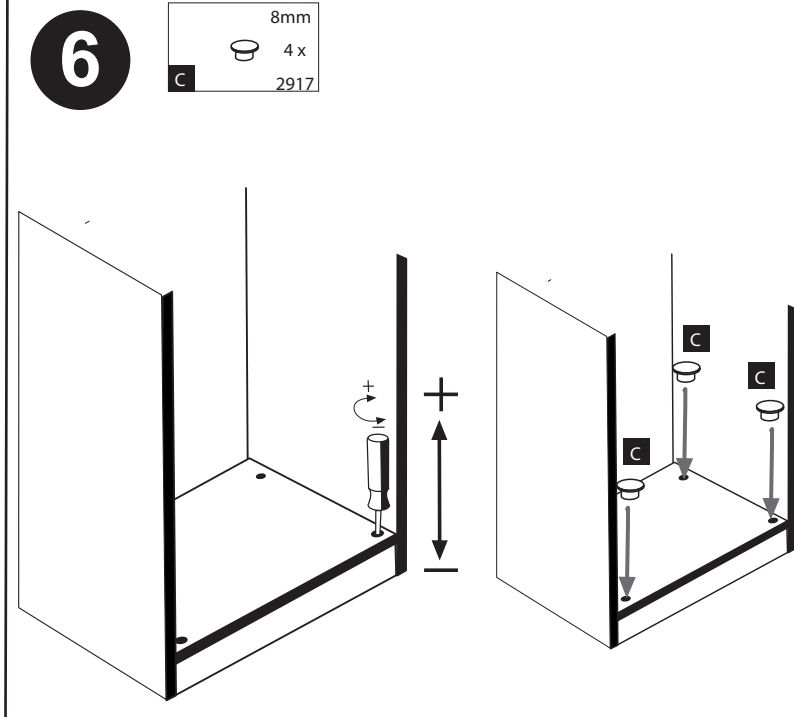
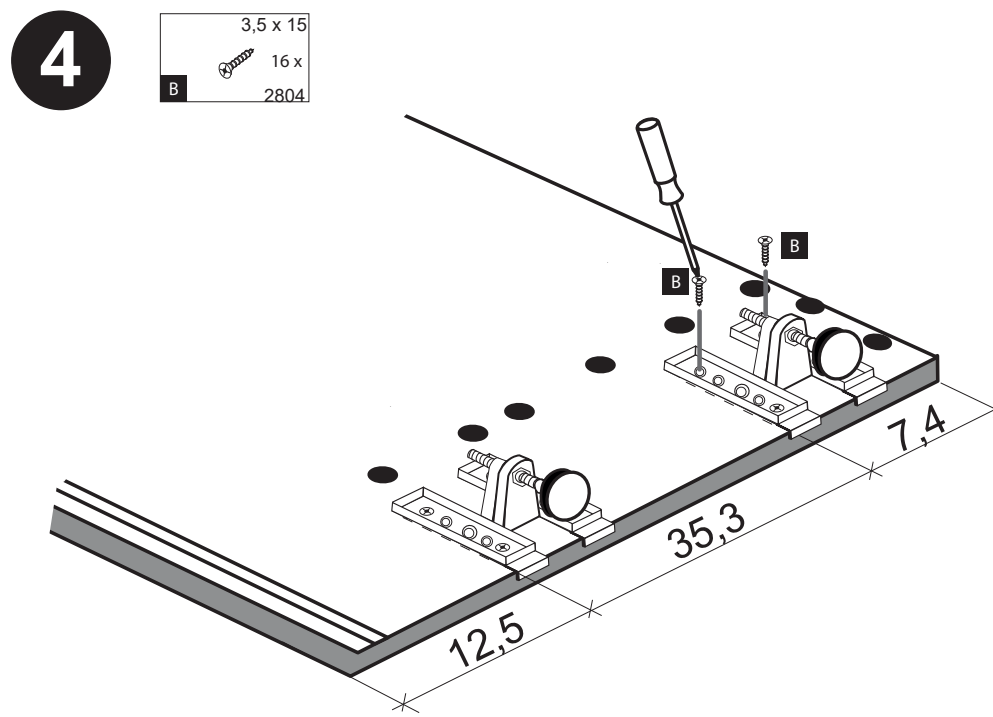
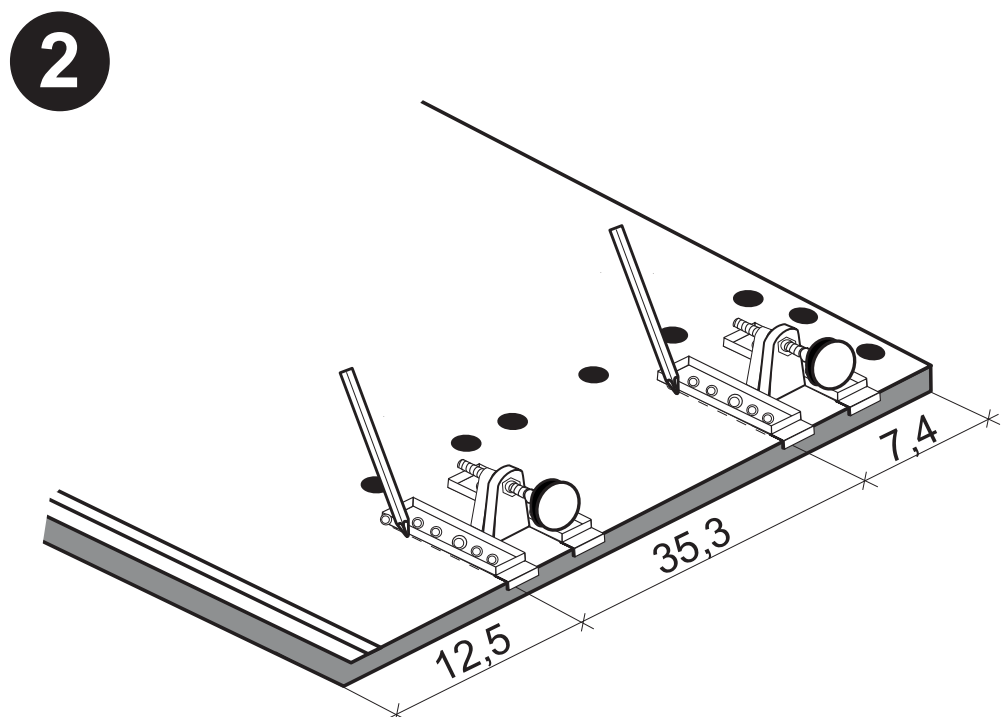
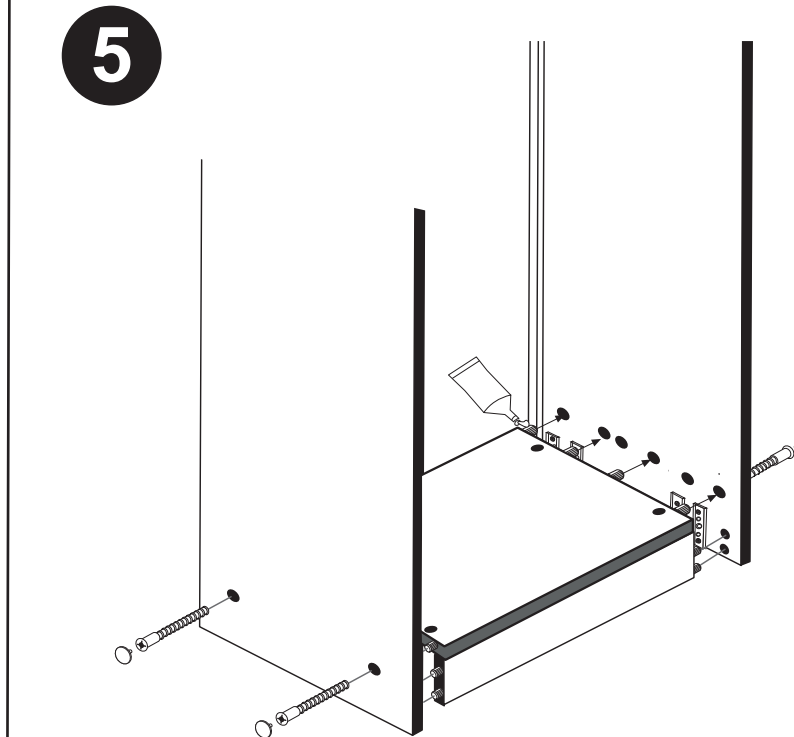
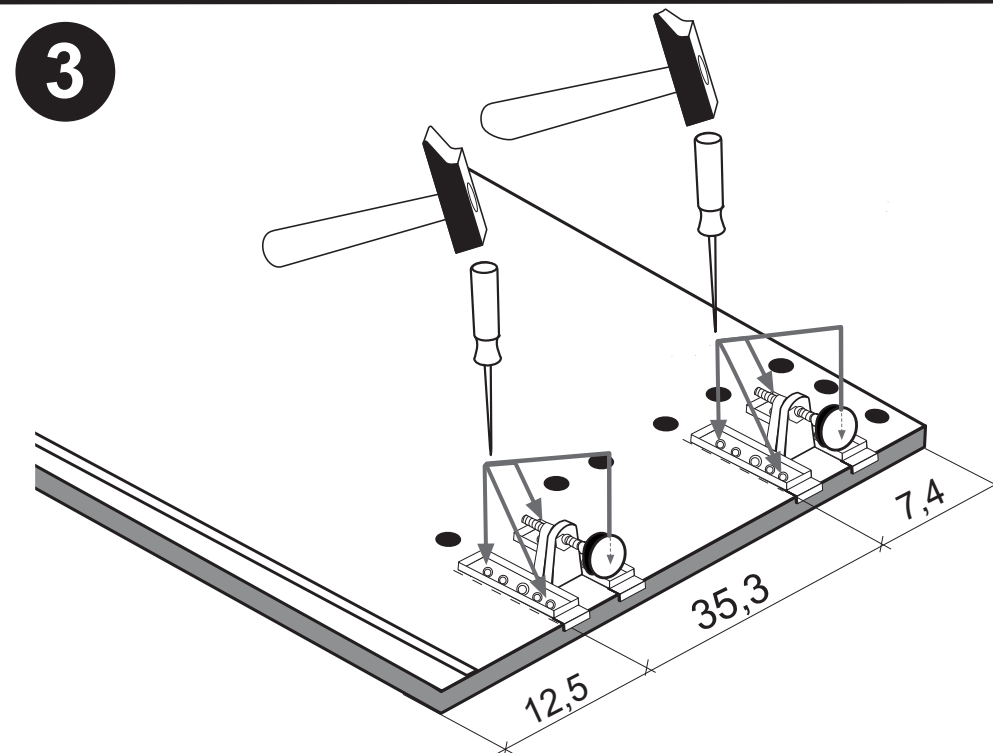
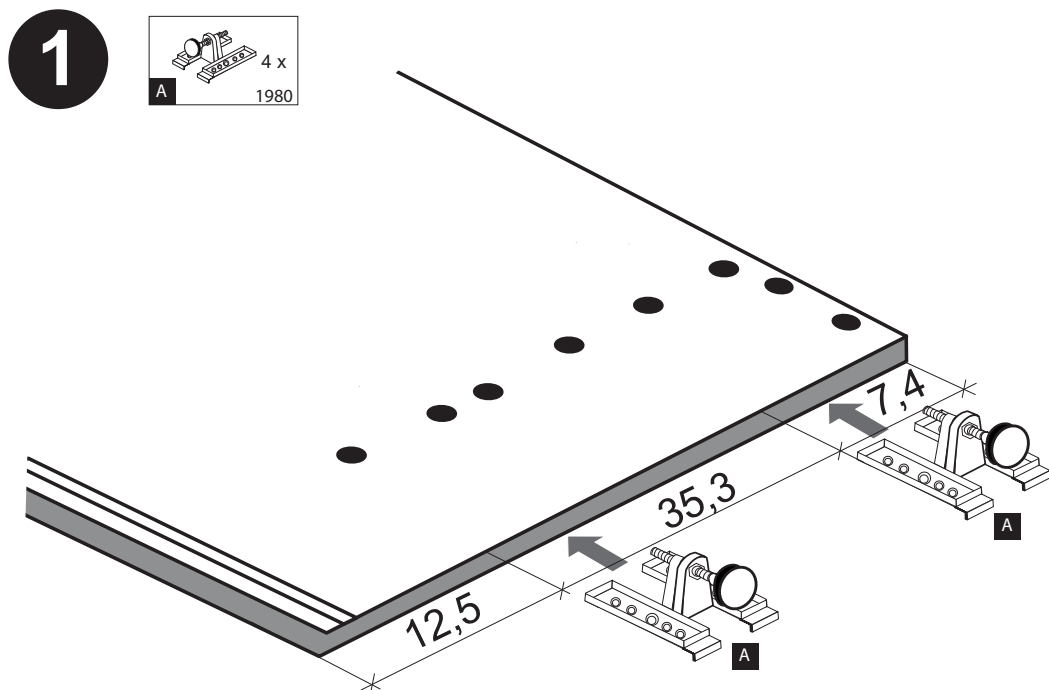

www.till-hilft.de

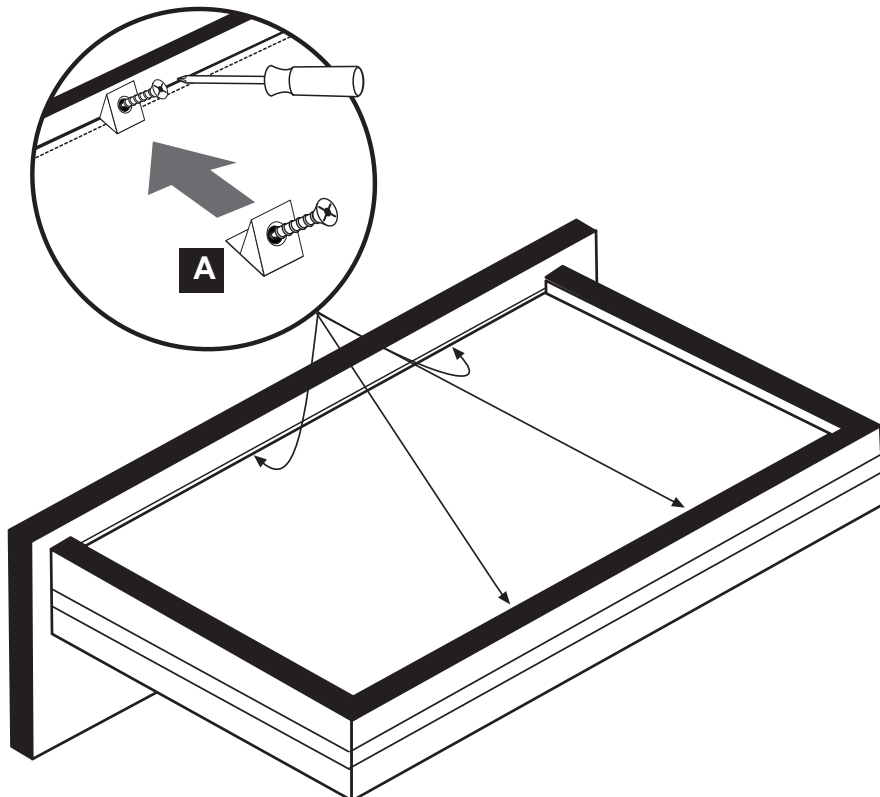
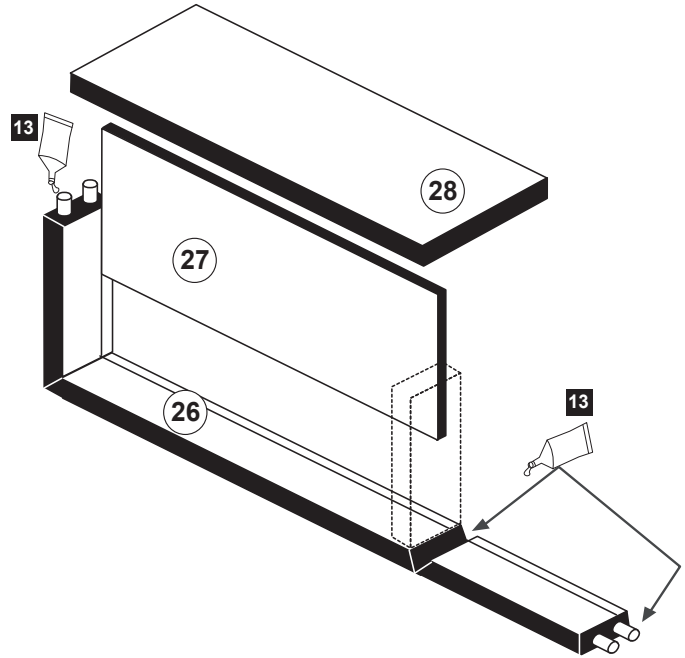
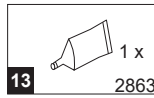
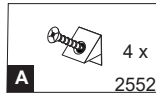
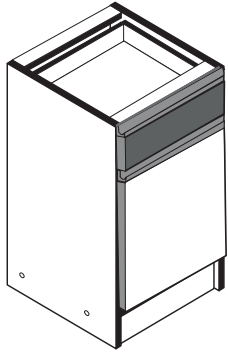
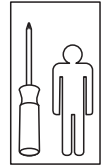

**D****Wichtige Pflegehinweise**

Bitte beachten Sie die wichtigen Pflegehinweise auf unserer Internetseite

www.till-hilft.de

Pflegehinweise

**PL****Ważne instrukcje dotyczące pielęgnacji**

Zwróć uwagę na ważną instrukcję dotyczącą pielęgnacji na naszej stronie internetowej

www.till-hilft.de

Pflegehinweise

**GB****Important care instructions**

Please note the important care instructions on our website

www.till-hilft.de

Pflegehinweise

**SK****Dôležité pokyny na starostlivosť**

Dbajte na dôležité pokyny týkajúce sa starostlivosti na našich webových stránkach

www.till-hilft.de

Pflegehinweise

**FR****Instructions d'entretien importantes**

S'il vous plaît noter les instructions de soins importants sur notre site Web

www.till-hilft.de

Pflegehinweise

**HU****Fontos kezelési utasítások**

Kérjük, vegye figyelembe a honlapunkon található fontos kezelési útmutatót

www.till-hilft.de

Pflegehinweise

**IT****Importanti istruzioni per la cura**

Si prega di notare le importanti istruzioni per la cura sul nostro sito web

www.till-hilft.de

Pflegehinweise

**RO****Instrucțiunile importante de îngrijire**

Rețineți instrucțiunile importante de îngrijire de pe site-ul nostru

www.till-hilft.de

Pflegehinweise

**NL****Belangrijke zorginstructies**

Let op de belangrijke zorginstructies op onze website

www.till-hilft.de

Pflegehinweise

**TR****Önemli bakım talimatları**

Lütfen web sitemizdeki önemli bakım talimatlarını dikkate alınız

www.till-hilft.de

Pflegehinweise

**CZ****Důležité pokyny pro péči**

Vezměte prosím na vědomí důležité pokyny pro péči na našich webových stránkách

www.till-hilft.de

Pflegehinweise

**RU****Важные инструкции по уходу**

Обратите внимание на важные инструкции по уходу на нашем веб-сайте

www.till-hilft.de

Pflegehinweise





87153.532

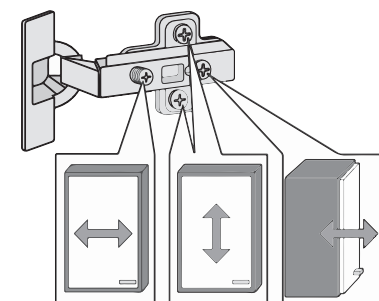
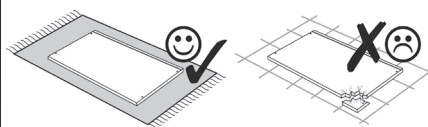
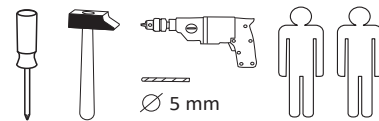

1 4 x 2827	2 8 x 30 20 x 2861	3 2 x 1503	4 2 x 1611	5 2 x 2886
6 4 x	7 Leim 1 x 2863	8 10 x 2862	9 3,5 x 15 4 x 2804	10 3,5 x 30 4 x 2807
11 1 x	12 2 x	13 2 x 2865	14 2 x 1 x	
A 4 x 1980	B 3,5 x 15 16 x 2804	C 8mm 4 x 2917		

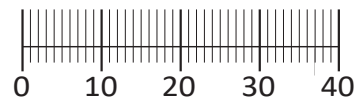

Das beigefügte Wandbefestigungsmaterial (Dübel und Schrauben) eignet sich nur für festes Mauerwerk (z.B.: Beton- oder Ziegelwände). Für andere Wandaufbauten sind eventuell Spezialdübel und andere Schrauben notwendig. Ziehen Sie gegebenenfalls eine Fachkraft zu Rate.

Приложенный материал для крепления к стене (дюбели и винты) пригоден только для жестких кладок (например, бетонные или кирпичные стены). Для других настенных конструкций необходимы смотря по обстоятельствам специальные дюбели и другие винты. При необходимости проконсультируйтесь у специалиста.

Zalączony materiał do mocowania do ściany (kolki rozprężne i wkręty) nadaje się tylko do ścian murowanych (np. z betonu lub cegieł). Do ścian wykonanych w innych technologiach konieczne być mogą specjalne kolki rozprężne i inne wkręty. W razie potrzeby skorzystaj z fachowej pomocy.

The accompanying wall mounting hardware (anchors and screws) is suitable only for solid masonry (eg concrete or brick walls). For other wall structures are possibly special anchor bolts and other necessary. Tighten if necessary, an expert.

De begeleidende wandmontage hardware (pluggen en schroeven) is alleen geschikt voor massief metselwerk (bijvoorbeeld beton of bakstenen muren). Voor andere muur structuren zijn eventueel bijzondere ankerbouten en andere noodzakelijke. Draai indien nodig, een deskundige.

Le mur d'accompagnement matériel de montage (chevilles et les vis) ne convient que pour la maçonnerie solide (par exemple en béton ou des murs de briques). Pour les structures de mur d'autres sont peut-être spéciale boulons d'ancrage et d'autres nécessaires. Serrer le cas échéant, un expert.

Il muro di accompagnamento hardware di montaggio (tasselli e viti) è'e adatto solo per muratura piena (ad esempio calcestruzzo o muratura). Per le altre strutture murarie sono forse speciali bulloni di ancoraggio e necessari di altri. Serrare se necessario, un esperto.

Ekteki duvara sabit montaj malzemeleri (dübel ve vidalar), sadece sağlam duvarlar için (örnek: beton veya tuğla) elverişlidir. Başka duvarlar için özel dübeller ve farklı vidalar gerekebilir. Gerektiğinde bir uzmana danışınız.

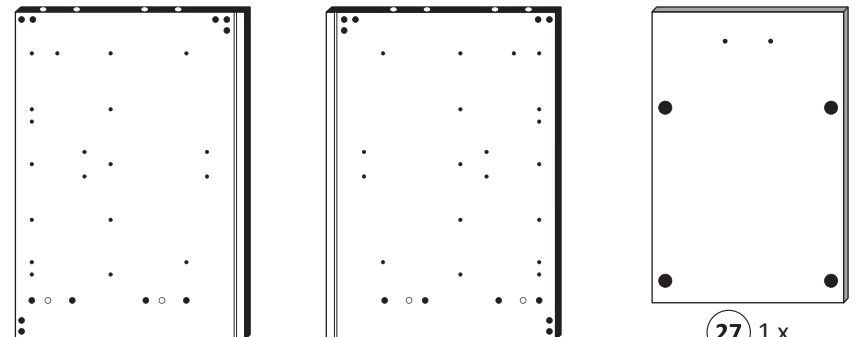

25 1 x

26 1 x

27 1 x



28 1 x

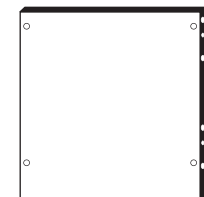

29 1 x



30 2 x



31 1 x

1

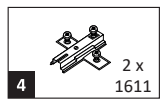

Bitte beachten !
In dieser Aufbauanleitung ist die Tür rechts angeschlagen. Soll die Tür links angeschlagen werden, müssen die Kreuzmontageplatten **4** auf das linke Seitenteil **25** montiert werden.

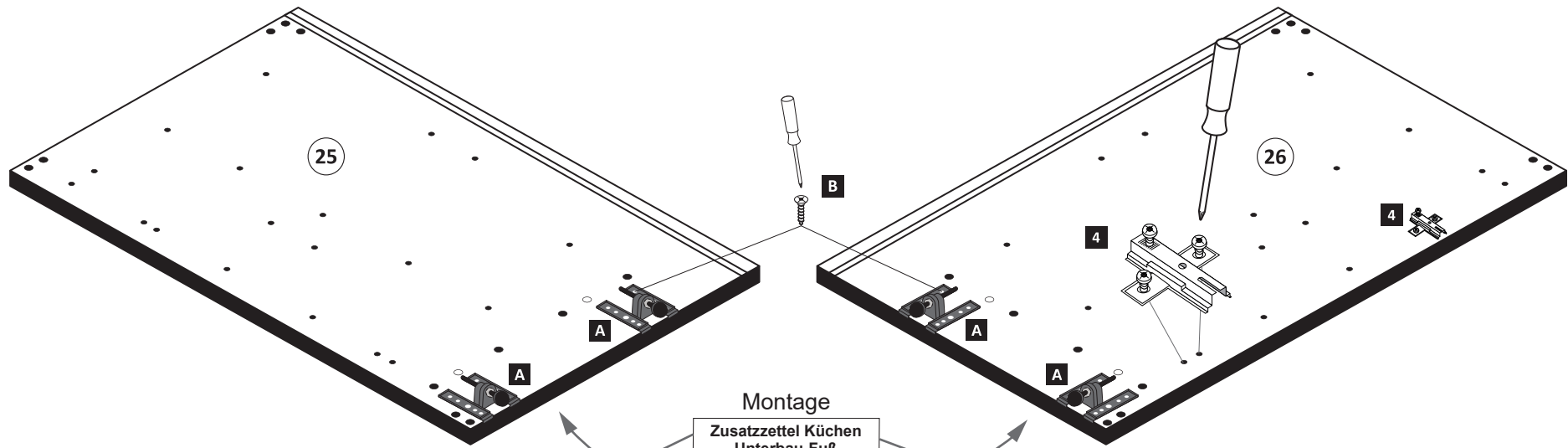
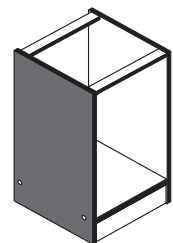
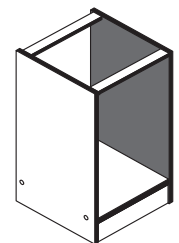

Montage
Zusatzteil Küchen
Unterbau-Fuß

2

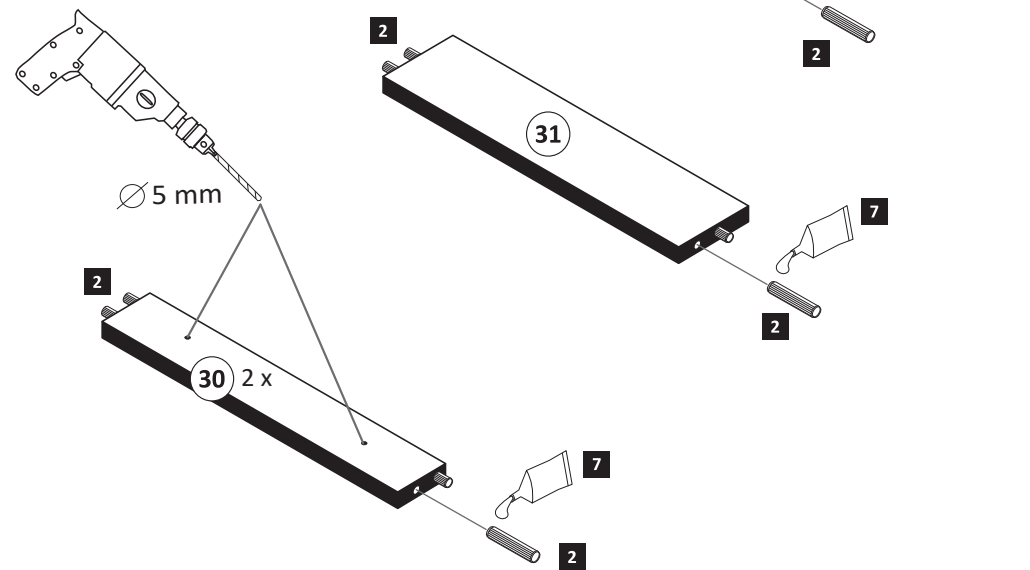
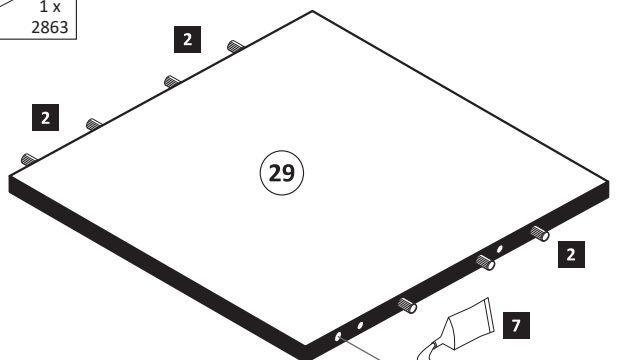
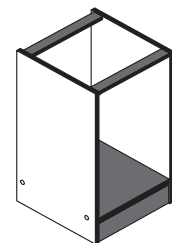
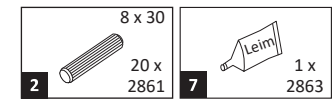

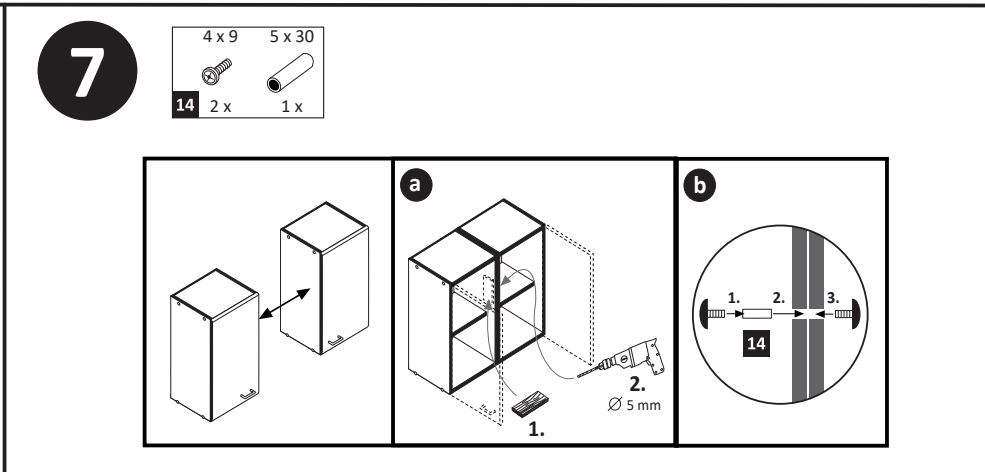
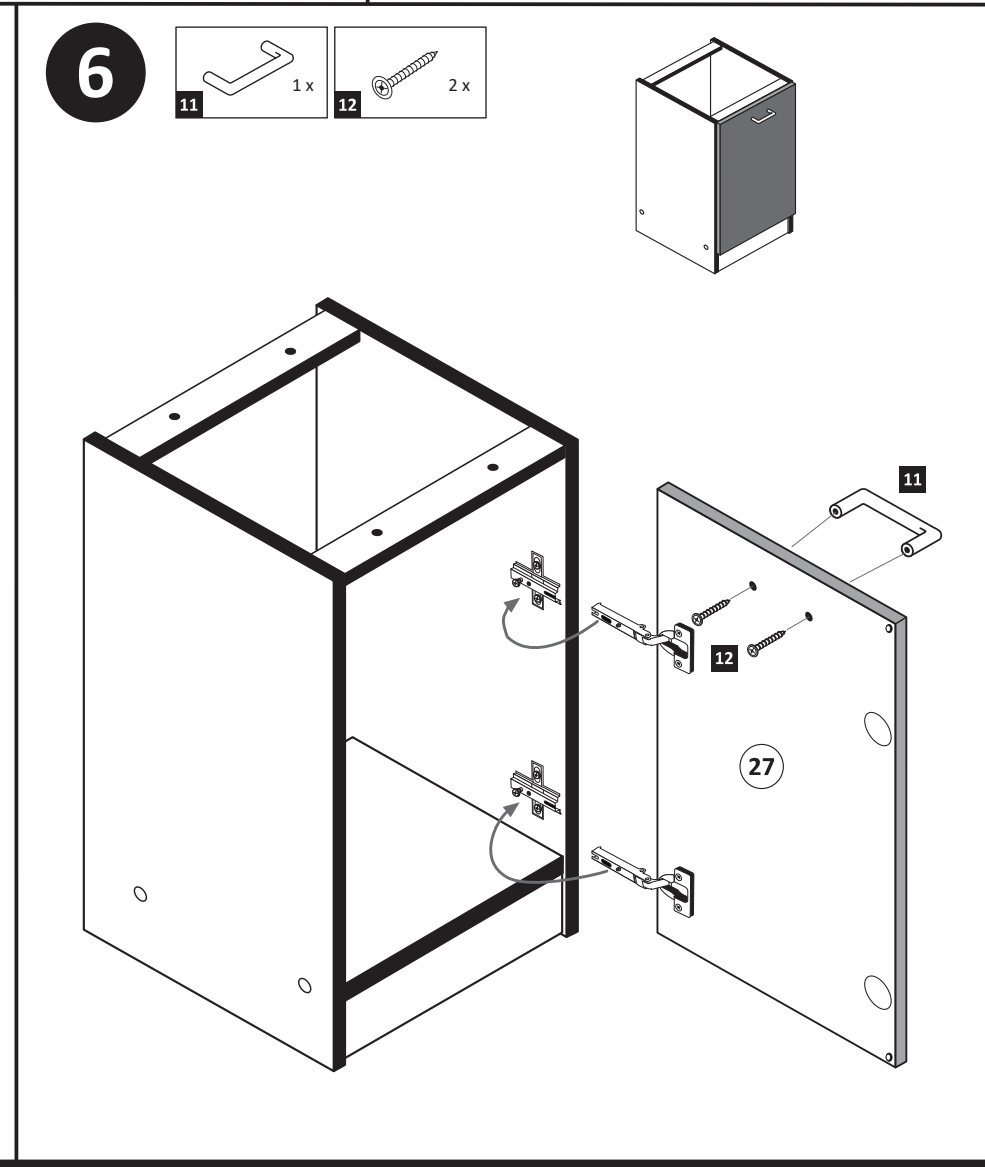
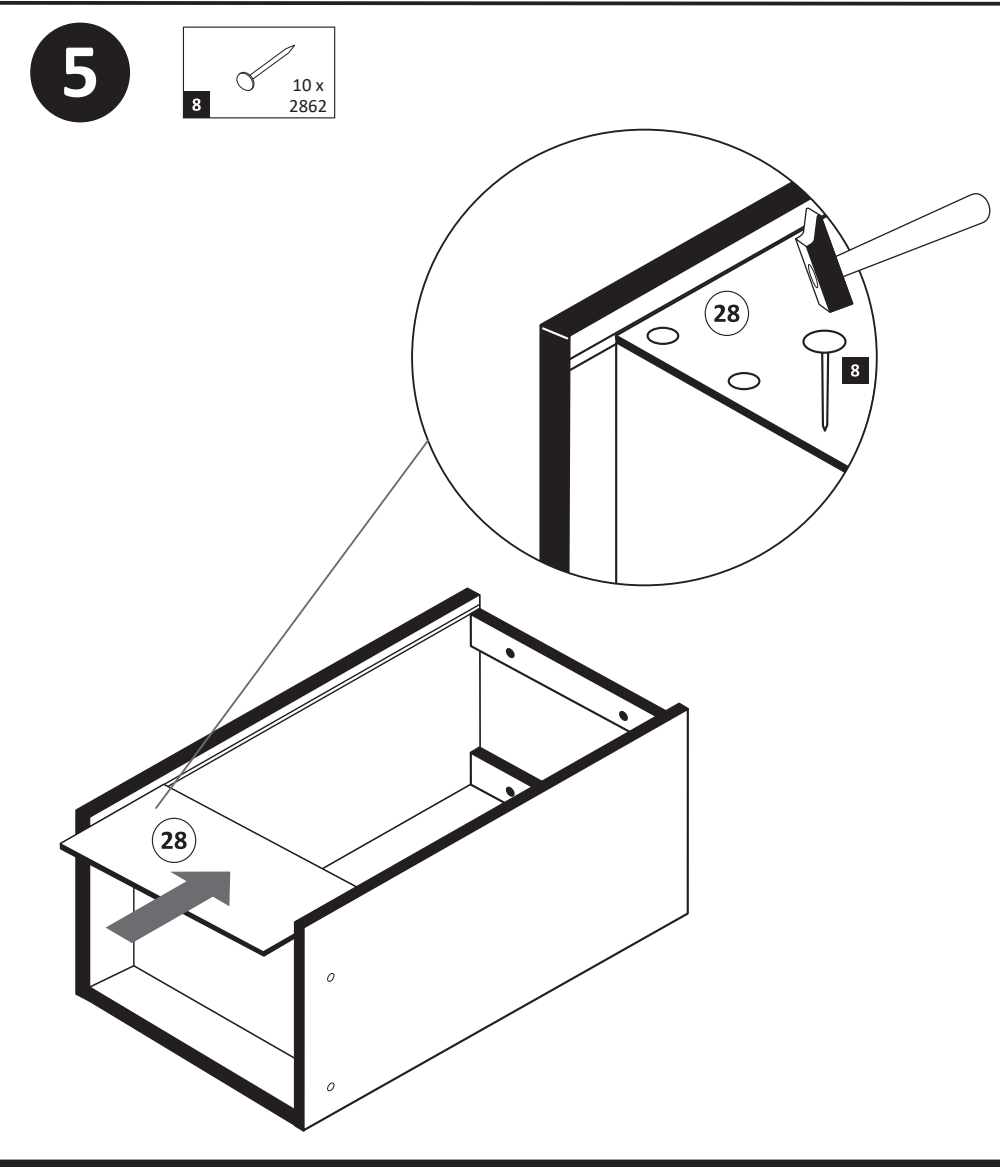
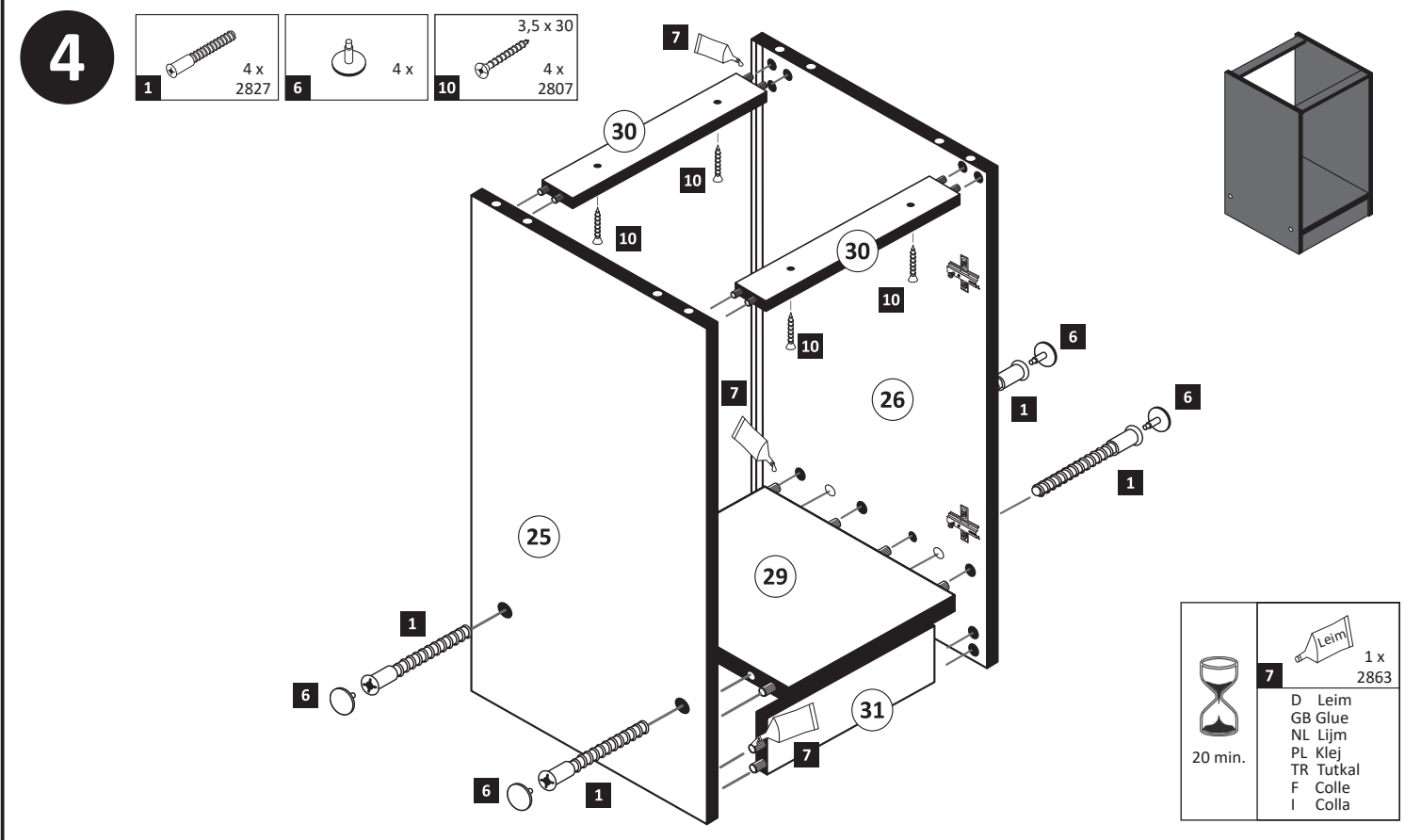
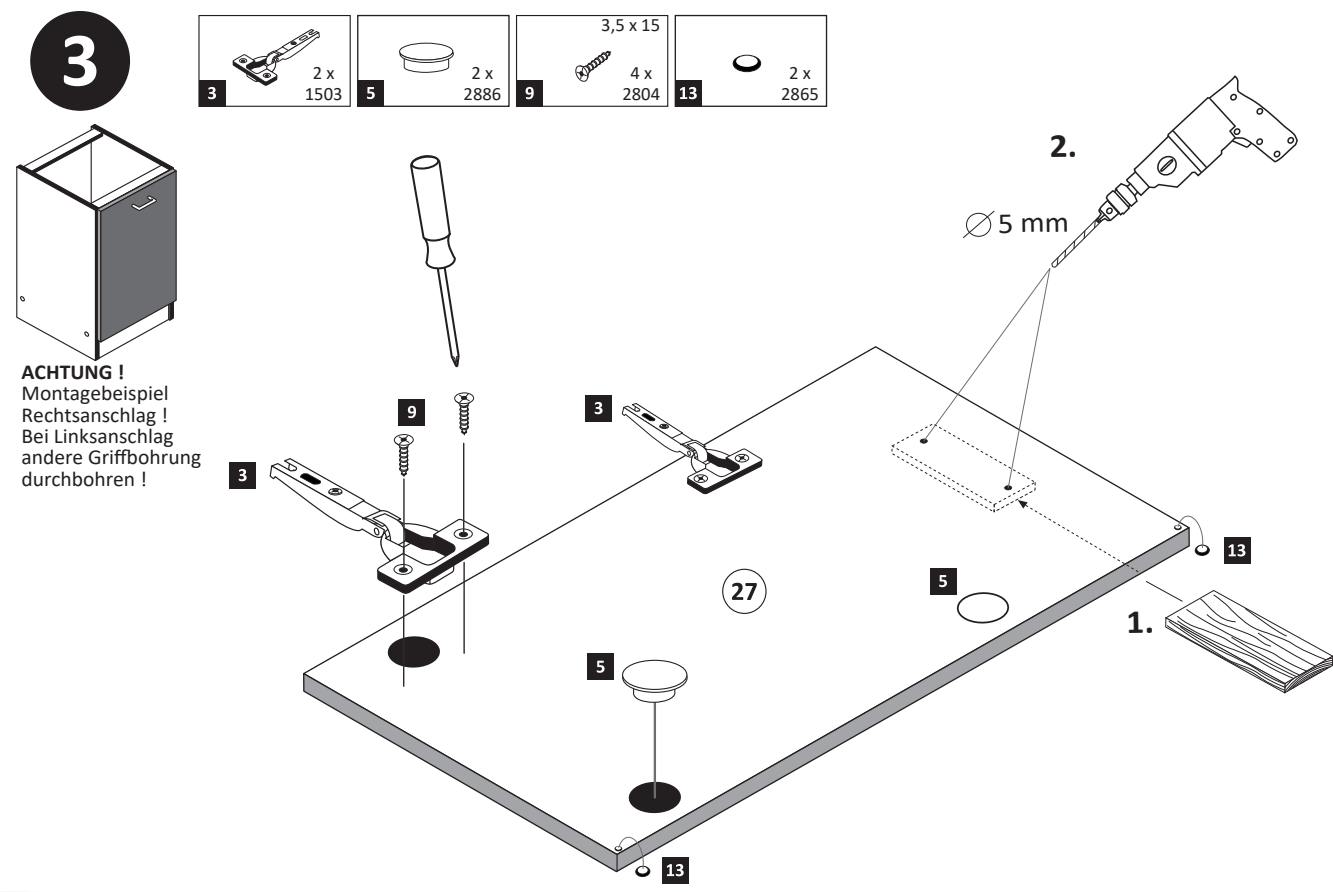

! Tipp !

Versiegeln Sie die Küche wie abgebildet gegen eventuell eindringende Feuchtigkeit.



(Silikon nicht im Lieferumfang enthalten)

Silikon

www.till-hilft.de

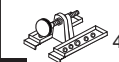

89930.330

 4 x 1980	 3,5 x 15 16 x 2804	 8mm 4 x 2917
---	--	--

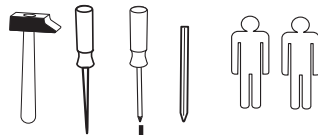
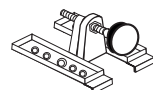
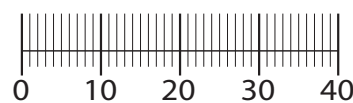

!! WICHTIG!!

Bitte fixieren den Schrank an der Wand bzw. an dem Nachbarschrank erst nach dem die Höheneinstellung mit dem Füßen durchgeführt ist.

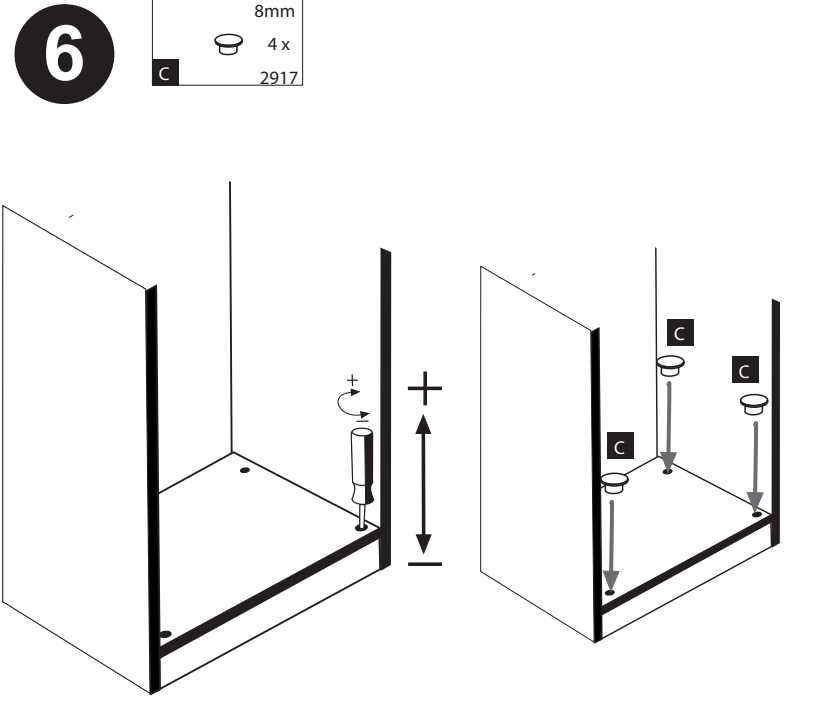
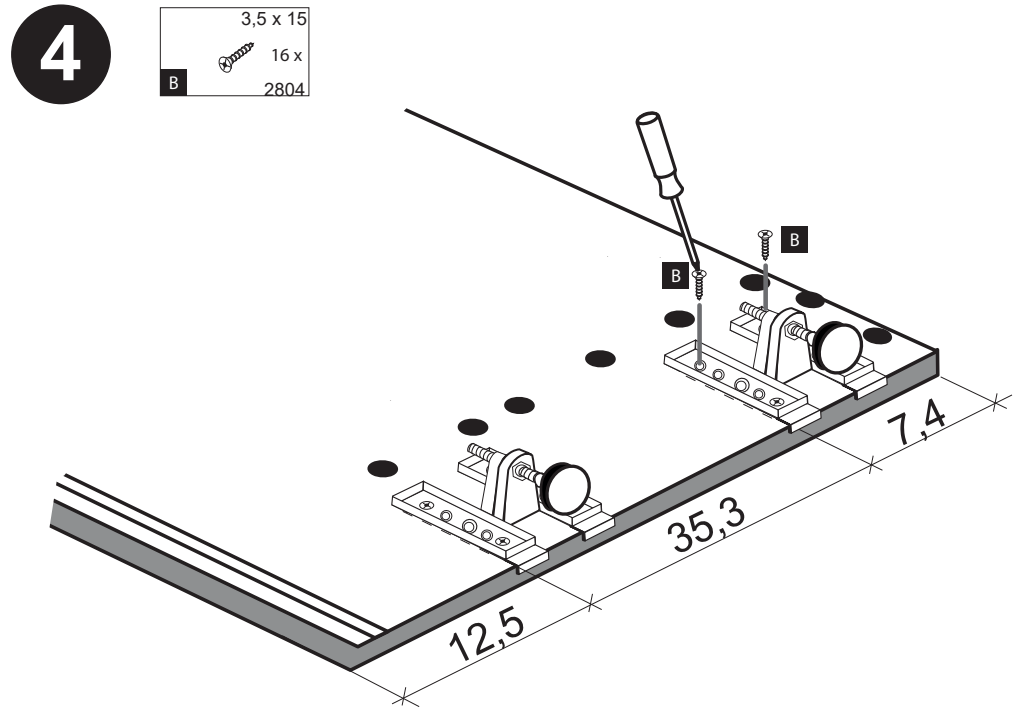
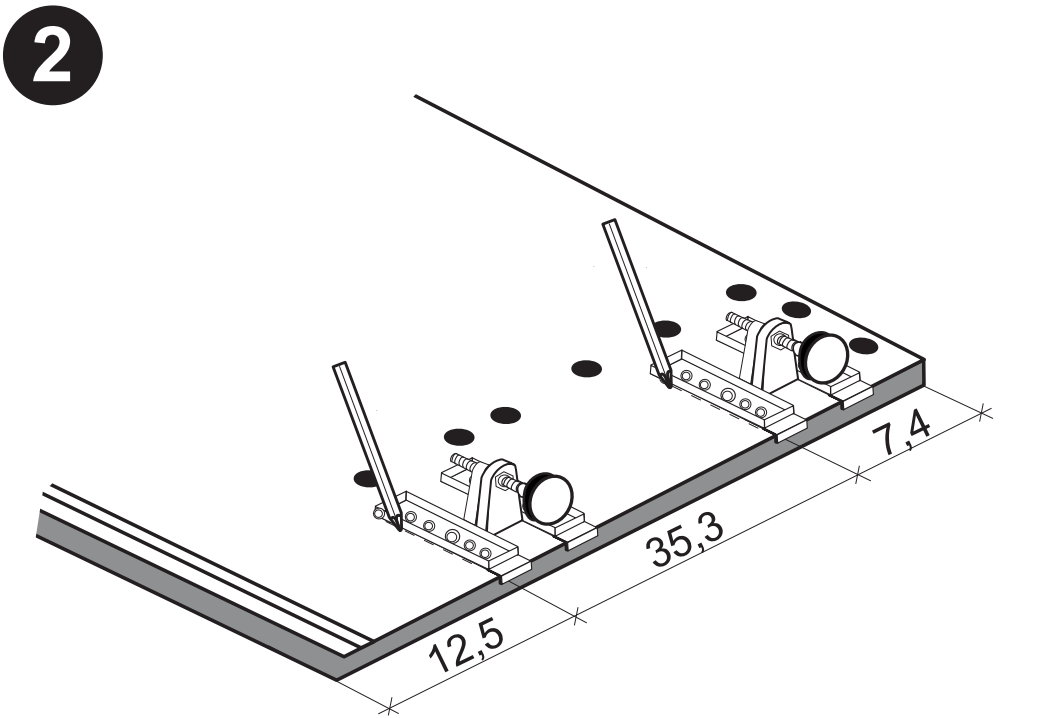
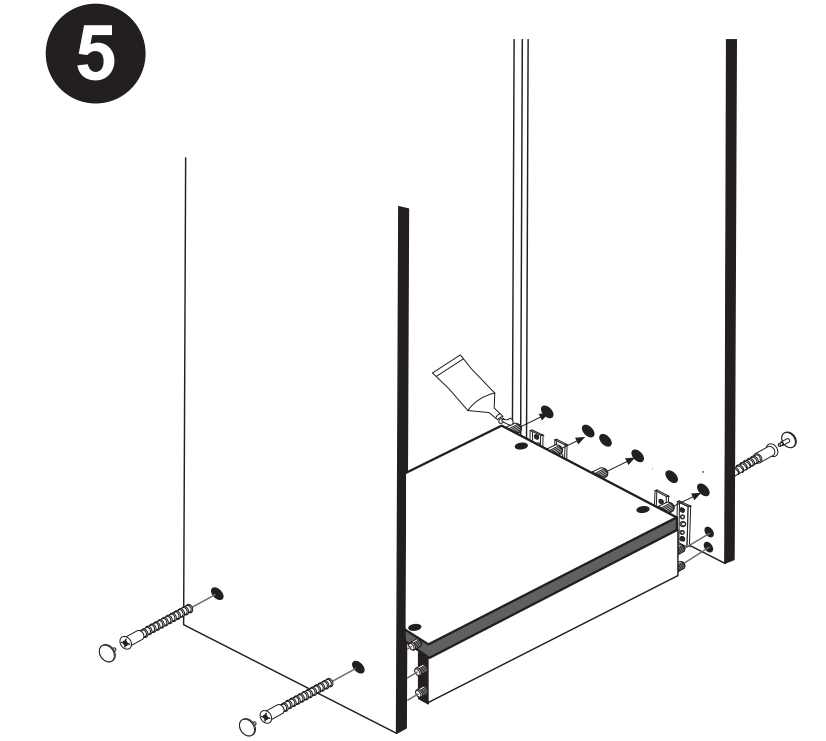
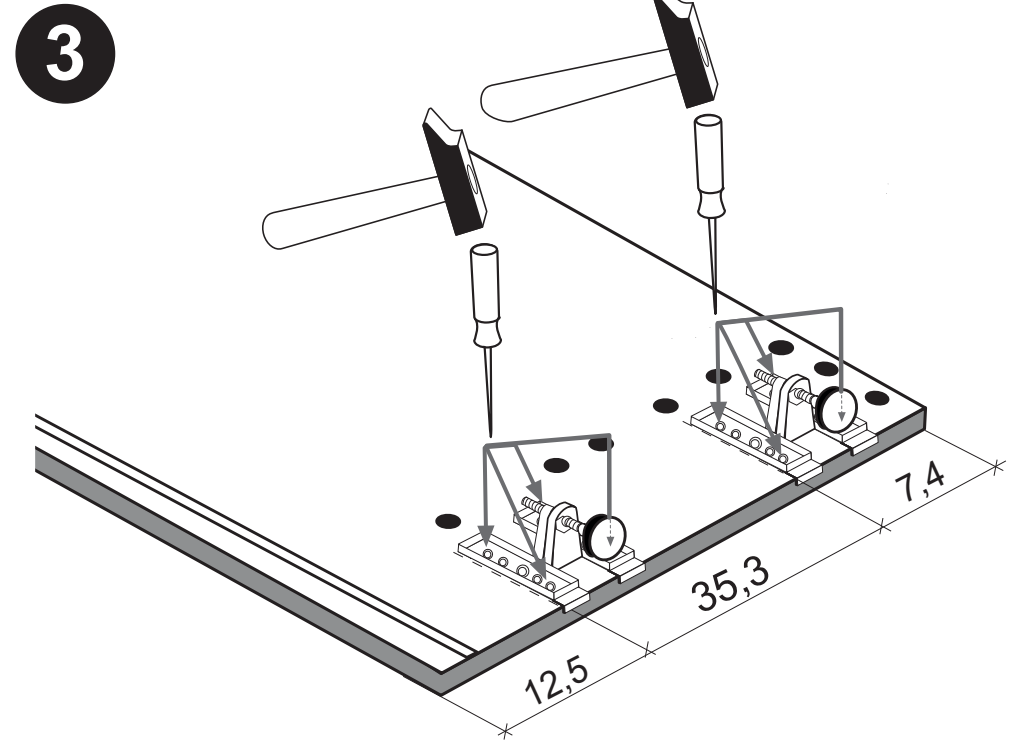
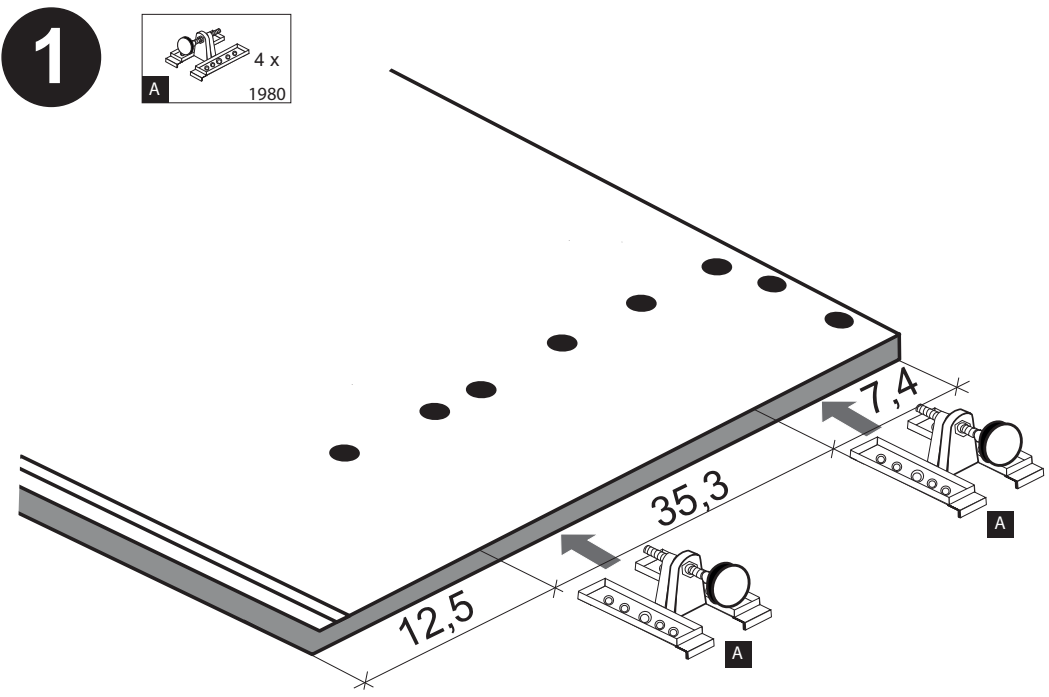

Beschlagteile

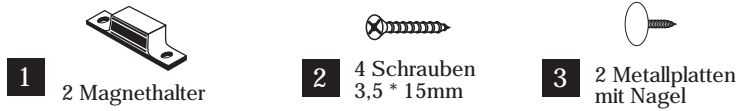

Bauteile

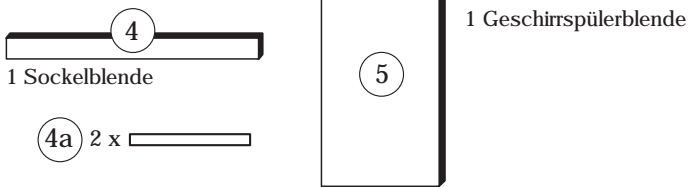
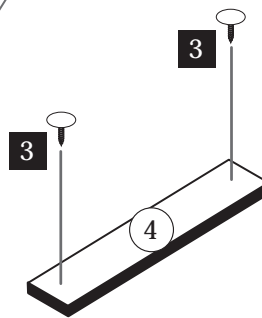
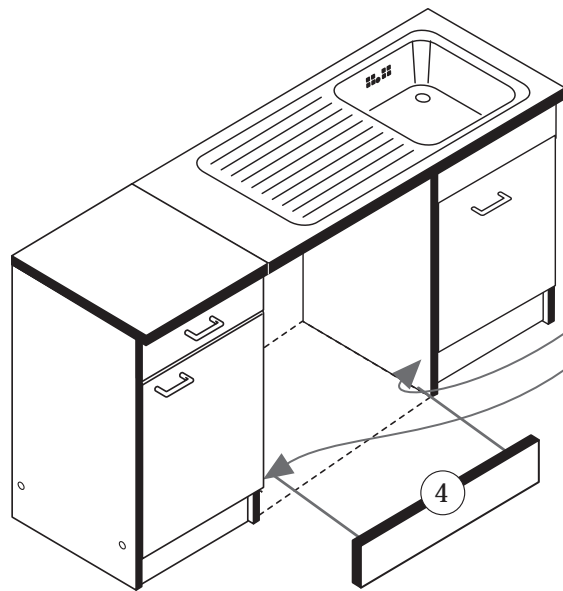
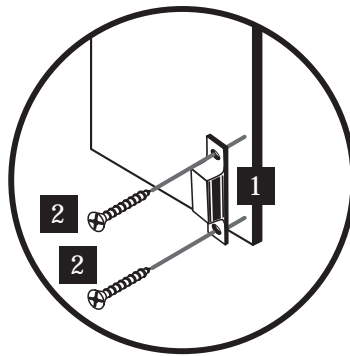
**A****a****b**

Wenn Sie die Möglichkeit haben, den linken Magnethalter an einen anderen Schrank zu montieren, dann gehen Sie so vor, wie in Variante (a). Sollten Sie die Möglichkeit nicht haben, dann kleben Sie den Geschirrspülerpülsocket (26) mit Hilfe der mitgelieferten Klebestreifen an den Geschirrspüler.

Bei der Geschirrspülfrontmontage gehen Sie bitte nach Hersteller Angaben vor.

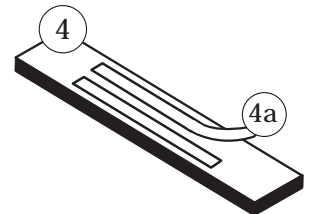
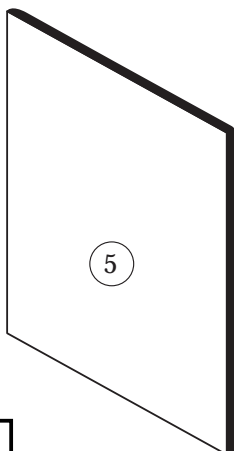
**B**

Die Anleitung zur Montage der Geschirrspülerblende an den Geschirrspüler entnehmen Sie bitte der Montageanleitung des Geschirrspülerherstellers.

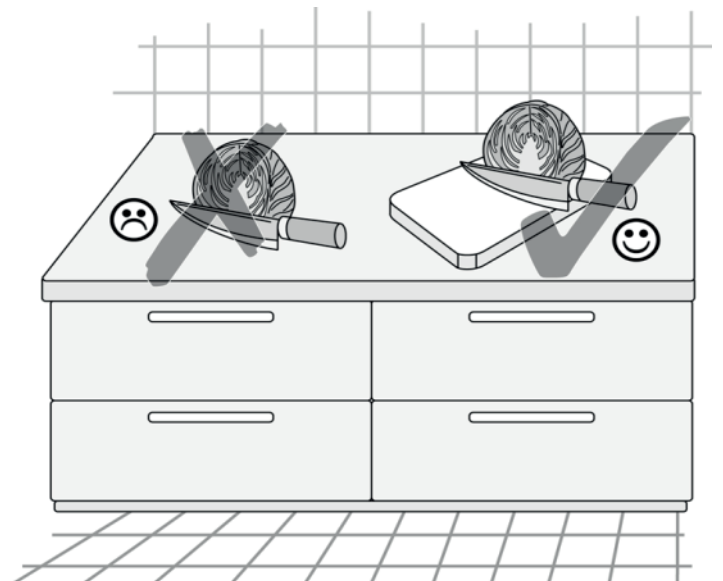
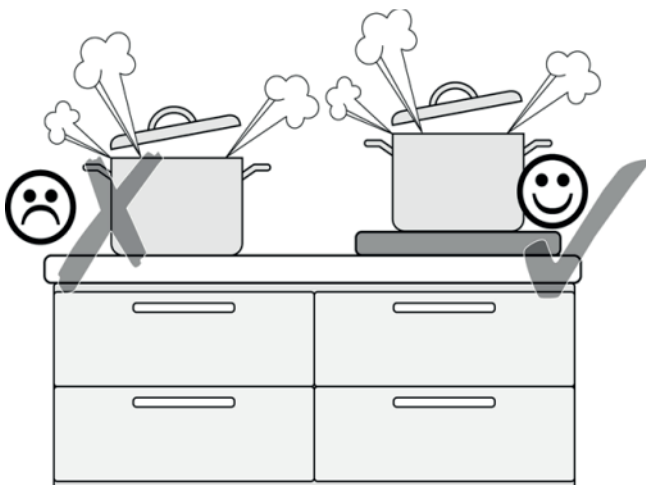

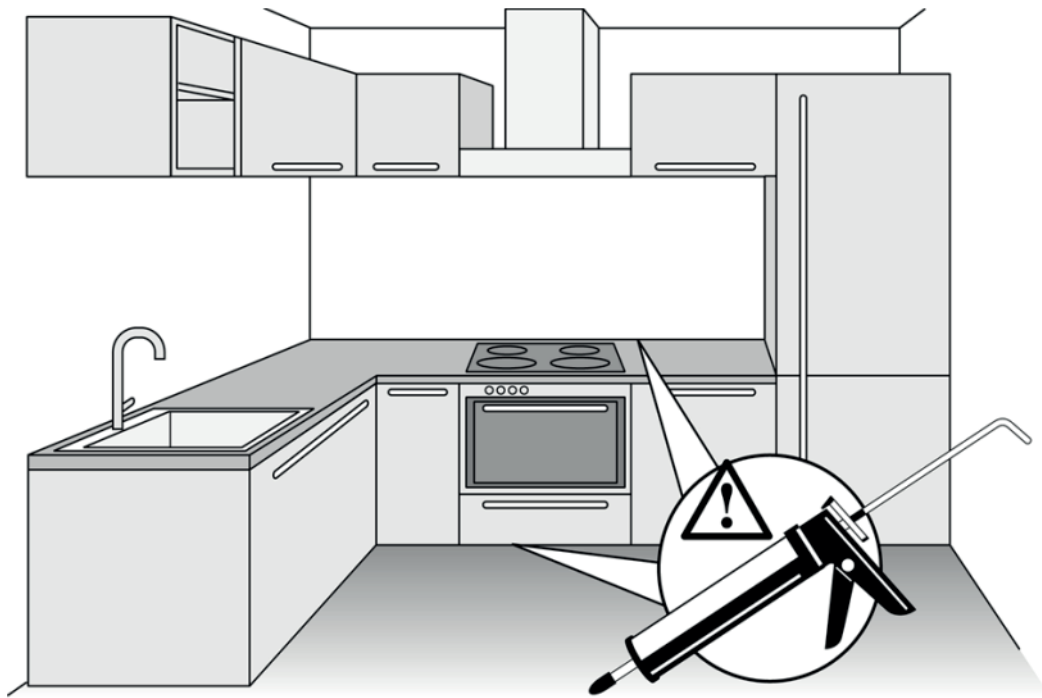
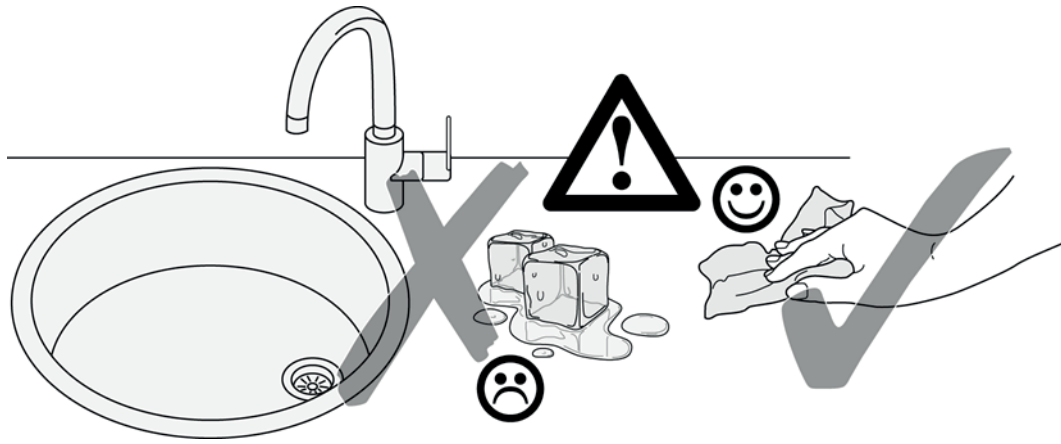



87020.530

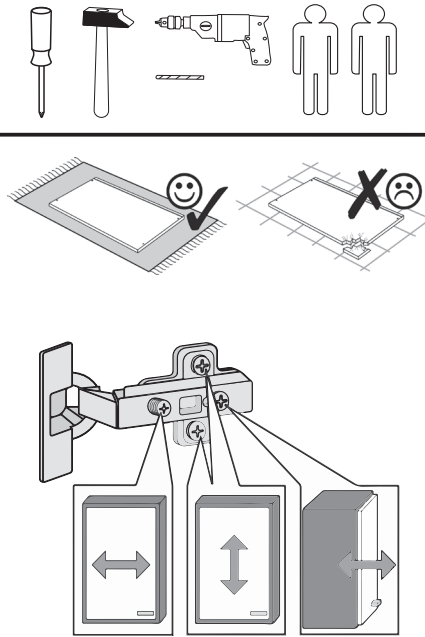
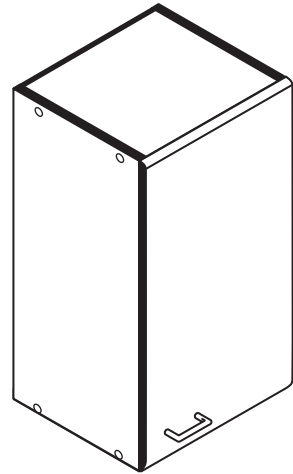

1	8 x	2	8 x	3	2 x	4	2 x	5	1 x
		2827		1503	1611				
6	2 x	7	2 x	8	4 x	9	4 x	10	2 x
			1 x		2804				
11	4 x	12	2 x		2 x	13	1 x		1 x
	2821	2840	2842	2881	2880				
14	10 x	15		24	8 x	25	1 x		
	2862	2865		2861	2863				

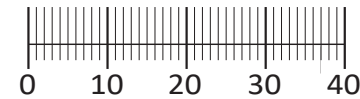

Das beigegefügte Wandbefestigungsmaterial (Dübel und Schrauben) eignet sich nur für festes Mauerwerk (z.B.: Beton- oder Ziegelwände). Für andere Wandaufbauten sind eventuell Spezialdübel und andere Schrauben notwendig. Ziehen Sie gegebenenfalls eine Fachkraft zu Rate.

De begeleidende wandmontage hardware (pluggen en schroeven) is alleen geschikt voor massief metselwerk (bijvoorbeeld beton of bakstenen muren). Voor andere muur structuren zijn eventueel bijzondere ankerbouten en andere noodzakelijke. Draai indien nodig, een deskundige.

Приложенный материал для крепления к стене (дюбели и винты) пригоден только для жестких кладок (например, бетонные или кирпичные стены). Для других настенных конструкций необходимы смотря по обстоятельствам специальные дюбели и другие винты. При необходимости проконсультируйтесь у специалиста.

Le mur d'accompagnement matériel de montage (chevilles et les vis) ne convient que pour la maçonnerie solide (par exemple en béton ou des murs de briques). Pour les structures de mur d'autres sont peut-être spéciale boulons d'ancrage et d'autres nécessaires. Serrer le cas échéant, un expert.

Załączony materiał do mocowania do ściany (kolki rozprężne i wkręty) nadaje się tylko do ścian murowanych (np. z betonu lub cegieł). Do ścian wykonanych w innych technologiach konieczne być mogą specjalne kolki rozprężne i inne wkręty. W razie potrzeby skorzystaj z fachowej pomocy

Il muro di accompagnamento hardware di montaggio (tasselli e viti) è adatto solo per muratura piena (ad esempio calcestruzzo o muratura). Per le altre strutture murarie sono forse speciali bulloni di ancoraggio e necessari di altri. Serrare se necessario, un esperto.

The accompanying wall mounting hardware (anchors and screws) is suitable only for solid masonry (eg concrete or brick walls). For other wall structures are possibly special anchor bolts and other necessary. Tighten if necessary, an expert.

Ekteki duvara sabit montaj malzemeleri (dübel ve vidalar), sadece sağlam duvarlar için (örnek: beton veya tuğla) elverişlidir. Başka duvarlar için özel dübeller ve farklı vidalar gerekebilir. Gerektiğinde bir uzmana danışınız.

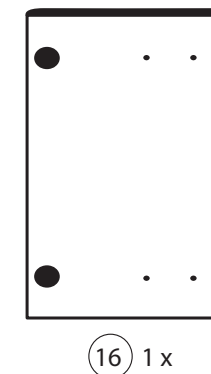

16 1 x

17 1 x

21 1 x



18 1 x

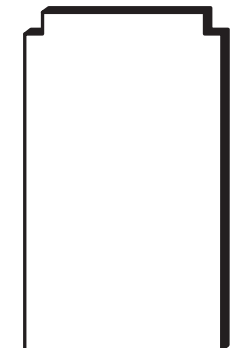
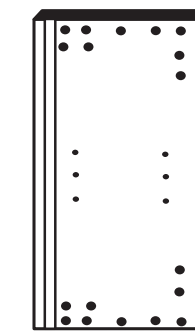
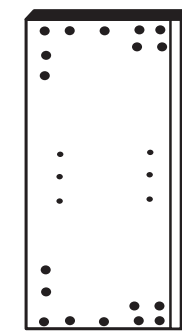

19 1 x

20 1 x

22 1 x

1



4	2 x	11	4 x	9	4 x	13	1 x		1 x
	1611	2821				2880	2881		

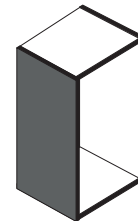

Bitte beachten!
In dieser Aufbauanleitung ist die Tür rechts angeschlagen.
Soll die Tür links angeschlagen werden, müssen die Kreuzmontageplatten 4 auf das linke Seitenteil 19 und die Scharniere 3 die gegenüberliegenden Bohrungen montiert werden.

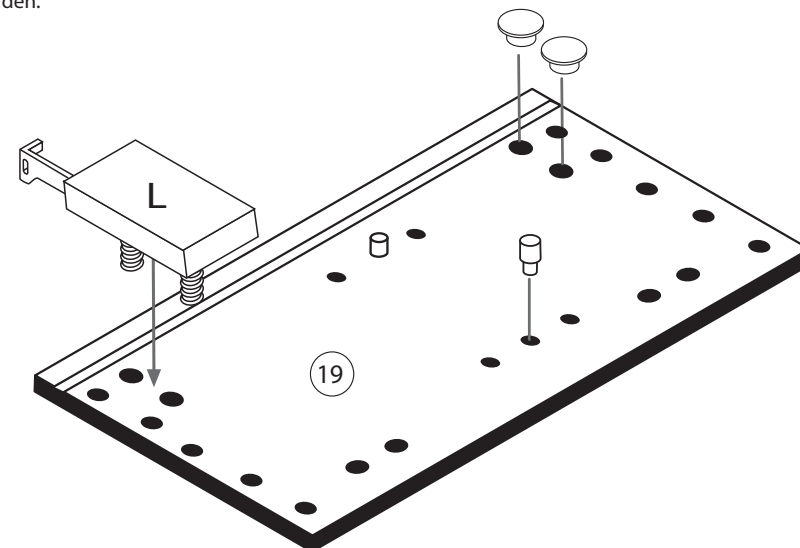
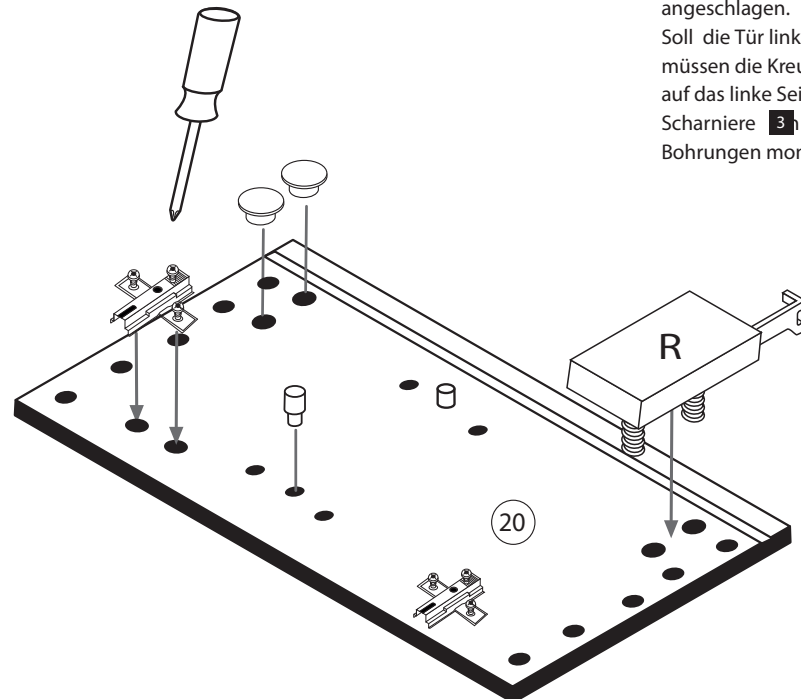

2

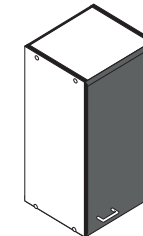

3	2 x	15	
	1503	2865	
8	4 x		
	2804		

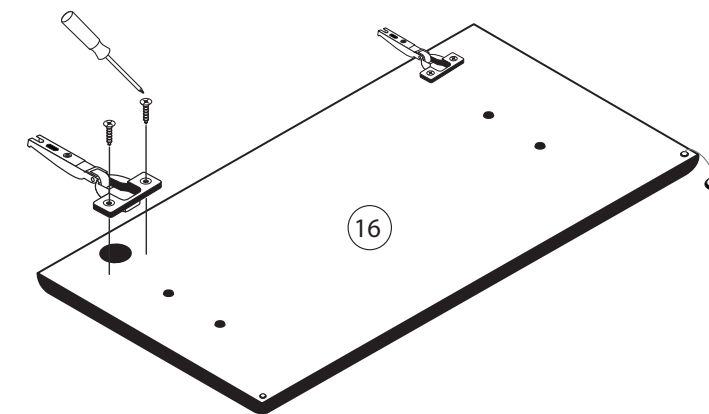

3

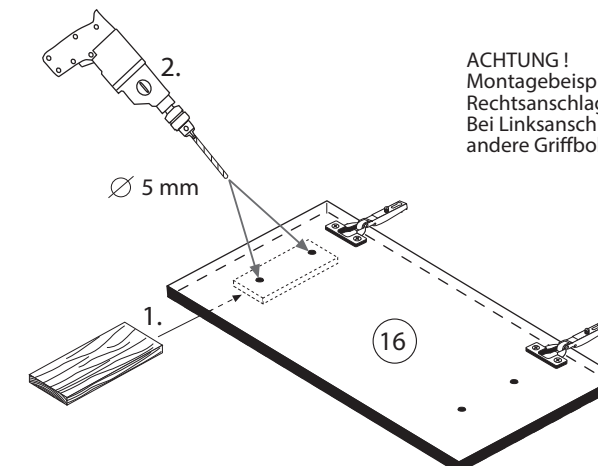
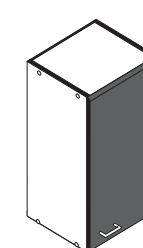

ACHTUNG!
Montagebeispiel
Rechtsanschlag!
Bei Linksanschlag
andere Griffbohrung durchbohren!

4

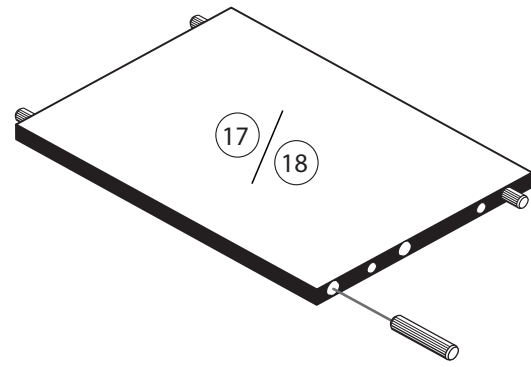

24	8 x 30 8 x 2861	25	1 x 2863
D Leim GB Glue NL Lijm PL Klej TR Tutkal F Colle I Colla			
20 min.			

5

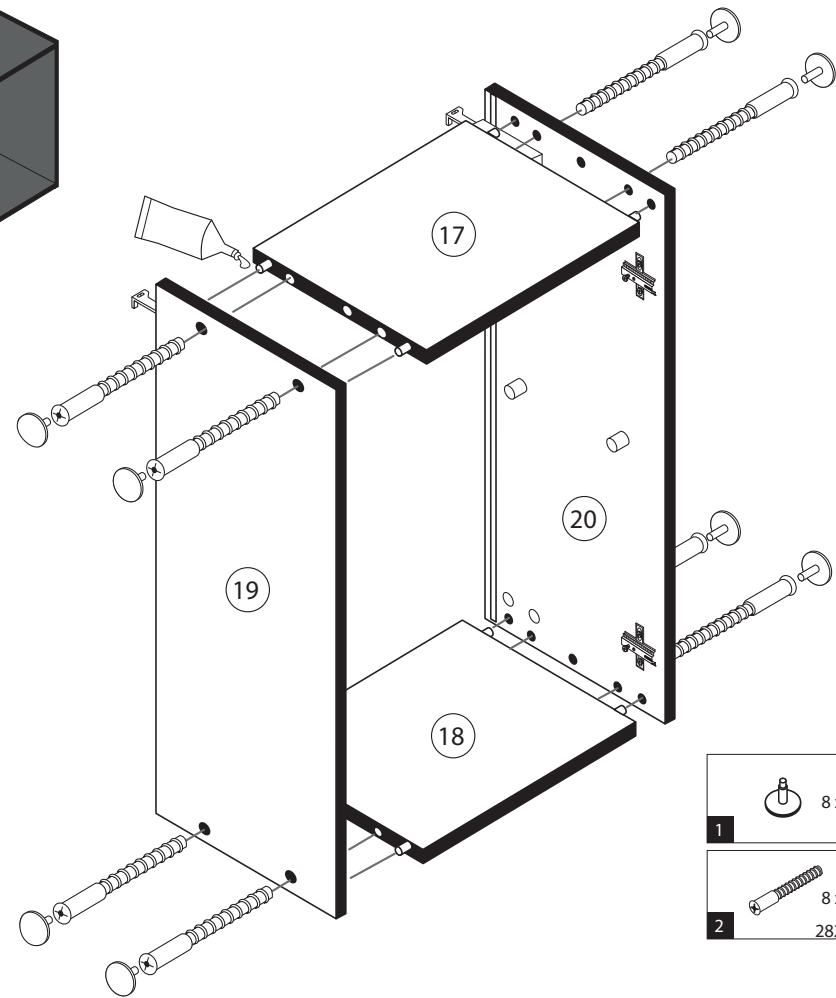

1	8 x	25	1 x 2863
2	8 x 2827	D Leim GB Glue NL Lijm PL Klej TR Tutkal F Colle I Colla	
20 min.			

7

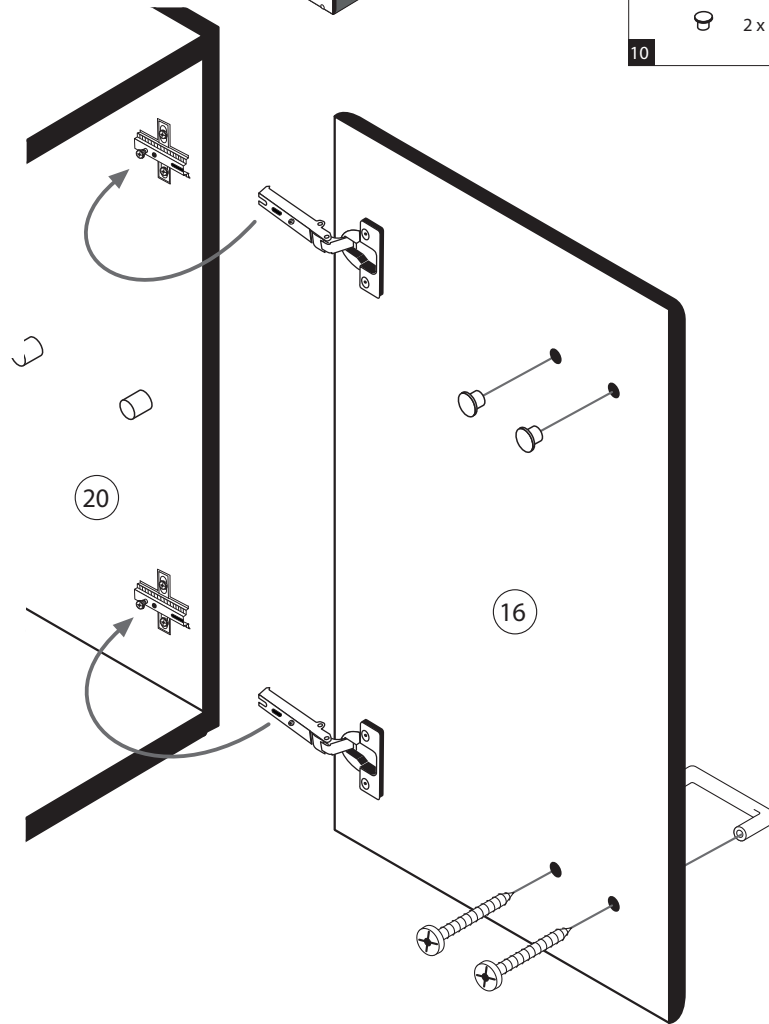
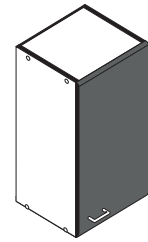

5	1 x
6	2 x
10	5mm 2 x

8

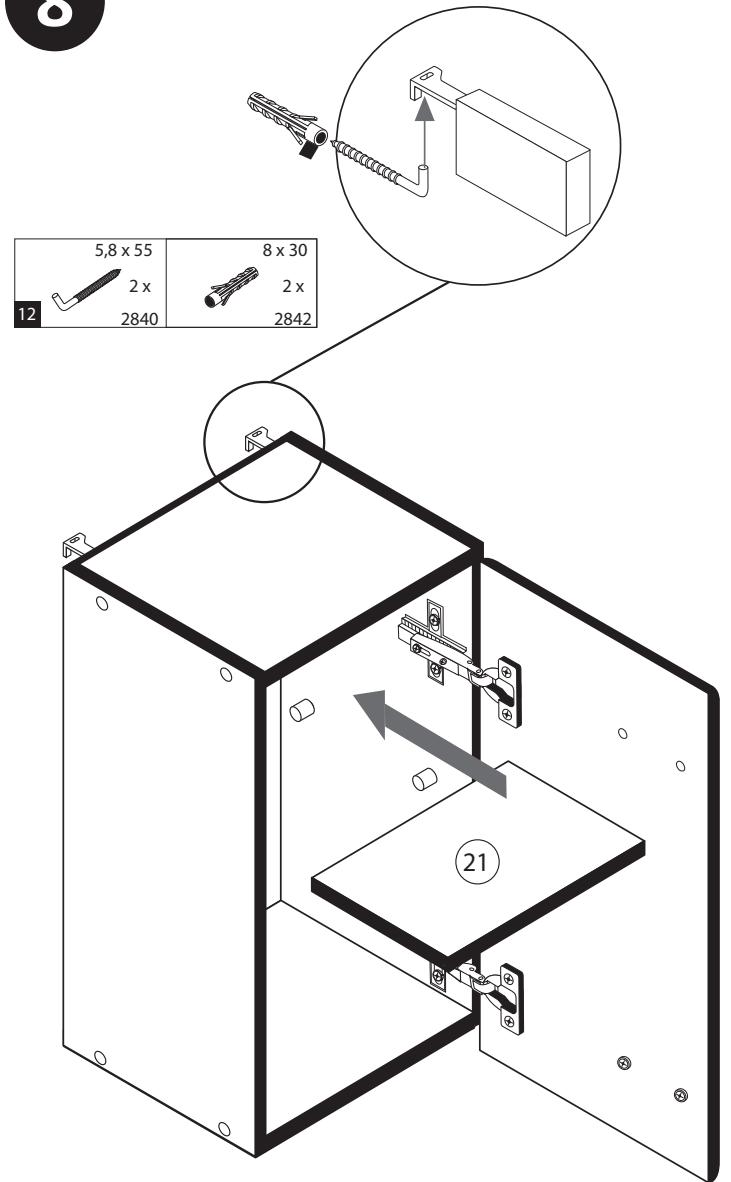

12	5,8 x 55 2 x 2840	8 x 30 2 x 2842
----	-------------------------	-----------------------

6

14	10 x 2862
----	--------------

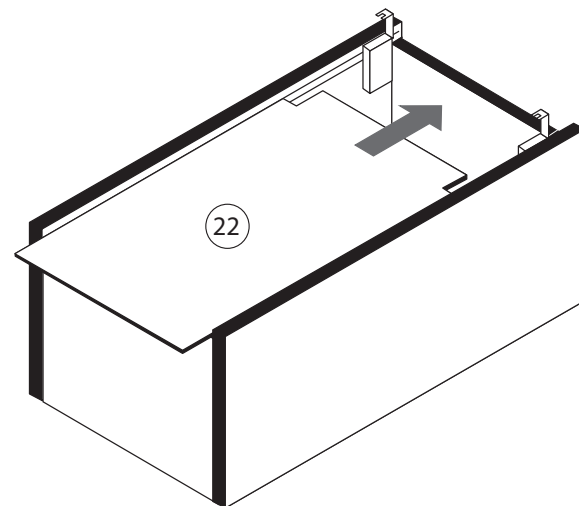
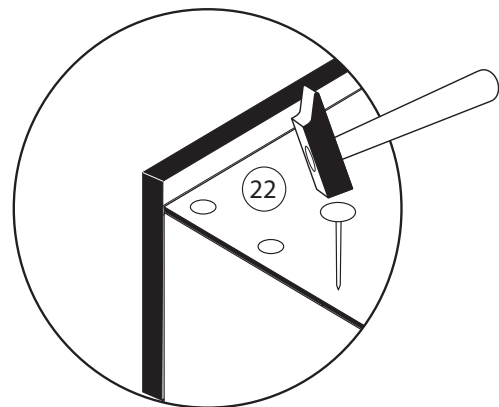

9

7	4 x 9 2 x	5 x 30 1 x
---	--------------	---------------

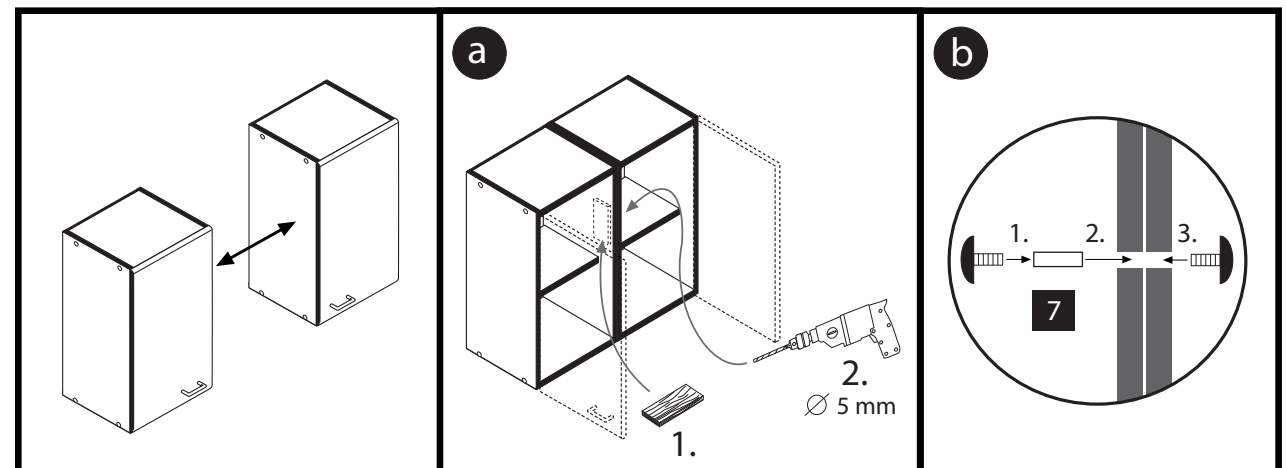



87243.730

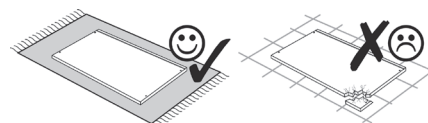
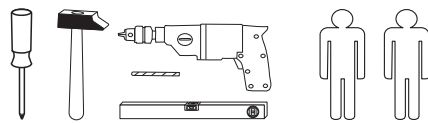
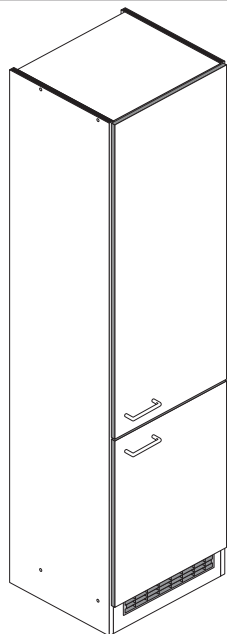

1 8 x 2827	2 8 x	3 8 x 30 24 x 2861	4 Leim 1 x 2863	5 5 x 1503
6 5 x 1611	7 3,5 x 15 4 x 2804	8 2 x	9 4 x 4	10 5mm 4 x 2855
11 4 x 2865	12 2 x 2527	13 4 x 45 2 x 2814	14 6 x 34 2 x 2844	15 4 x 9 5 x 30 2 x 1 x
16 2 x 2532	17 1 x 4940	A 4 x 1980	B 3,5 x 15 16 x 2804	C 8mm 4 x 2917

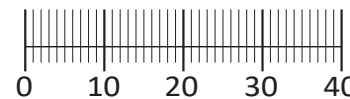

Das beigefügte Wandbefestigungsmaterial (Dübel und Schrauben) eignet sich nur für festes Mauerwerk (z.B.: Beton- oder Ziegelwände). Für andere Wandaufbauten sind eventuell Spezialdübel und andere Schrauben notwendig. Ziehen Sie gegebenenfalls eine Fachkraft zu Rate.

De begeleidende wandmontage hardware (pluggen en schroeven) is alleen geschikt voor massief metselwerk (bijvoorbeeld beton of bakstenen muren). Voor andere muur structuren zijn eventueel bijzondere ankerbouten en andere noodzakelijke. Draai indien nodig, een deskundige.

Приложенный материал для крепления к стене (дюбели и винты) пригоден только для жестких кладок (например, бетонные или кирпичные стены). Для других настенных конструкций необходимы смотря по обстоятельствам специальные дюбели и другие винты. При необходимости проконсультируйтесь у специалиста.

Le mur d'accompagnement matériel de montage (chevilles et les vis) n'est adapté que pour la maçonnerie solide (par exemple en béton ou des murs de briques). Pour les structures de mur d'autres sont peut-être spéciale boulons d'ancrage et d'autres nécessaires. Serrer le cas échéant, un expert.

Załączony materiał do mocowania do ściany (kolki rozprężne i wkręty) nadaje się tylko do ścian murowanych (np. z betonu lub cegiel). Do ścian wykonanych w innych technologiach konieczne być mogą specjalne kolki rozprężne i inne wkręty. W razie potrzeby skorzystaj z fachowej pomocy

Il muro di accompagnamento hardware di montaggio (tasselli e viti) è'e adatto solo per muratura piena (ad esempio calcestruzzo o muratura). Per le altre strutture murarie sono forse speciali bulloni di ancoraggio e necessari di altri. Serrare se necessario, un esperto.

The accompanying wall mounting hardware (anchors and screws) is suitable only for solid masonry (eg concrete or brick walls). For other wall structures are possibly special anchor bolts and other necessary. Tighten if necessary, an expert.

Ekteki duvarar sabit montaj malzemeleri (dübel ve vidalar), sadece sağlam duvarlar için (örnek: beton veya tuğla) elverişlidir. Başka duvarlar için özel dübeller ve farklı vidalar gerekebilir. Gerektiğinde bir uzmana danışınız.

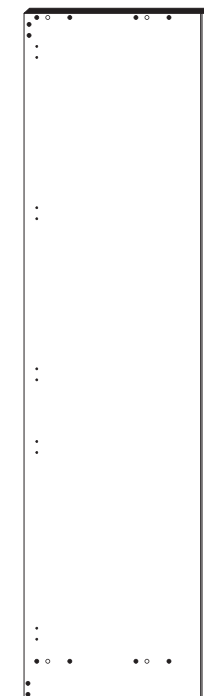

20 1 x



21 1 x

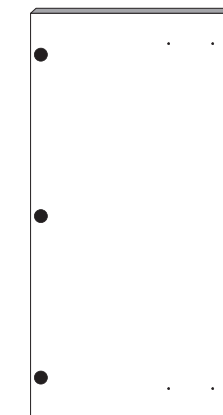

22 1 x

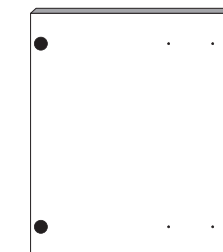

23 1 x



26 1 x



27 1 x

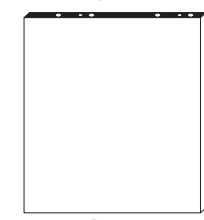

24 1 x

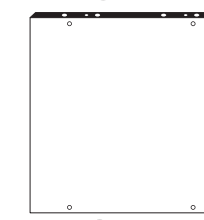

25 1 x

1

6 5 x 1611	7 3,5 x 15 4 x 2804	12 2 x 2527	A 4 x 1980	B 3,5 x 15 16 x 2804
---------------	---------------------------	----------------	---------------	----------------------------

Bitte beachten !
In dieser Aufbauanleitung ist die Tür rechts angeschlagen. Soll die Tür links angeschlagen werden, müssen die Kreuzmontageplatten 6 auf das linke Seitenteil 20 montiert werden.

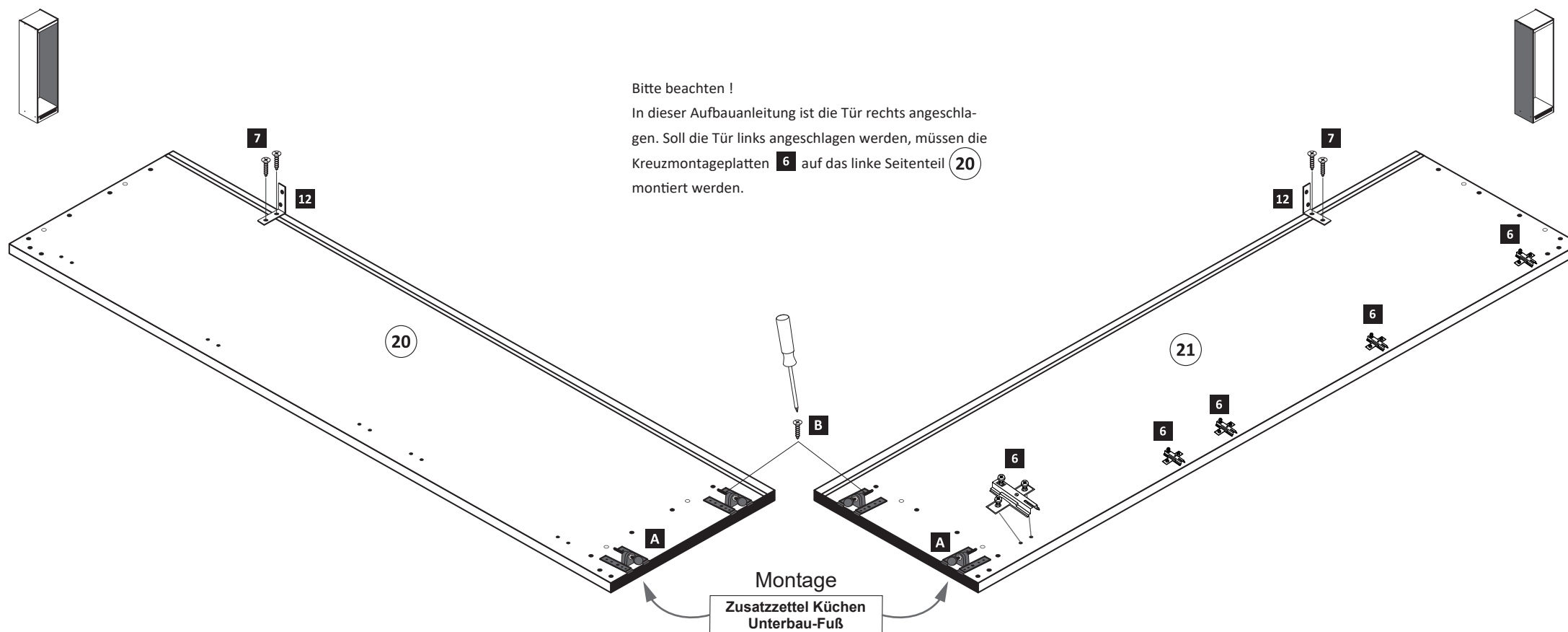

Montage
Zusatzsetteil Küchen
Unterbau-Fuß

2

3 8 x 30 24 x 2861	4 Leim 1 x 2863	16 2 x 2532	17 1 x 4940
--------------------------	-----------------------	----------------	----------------

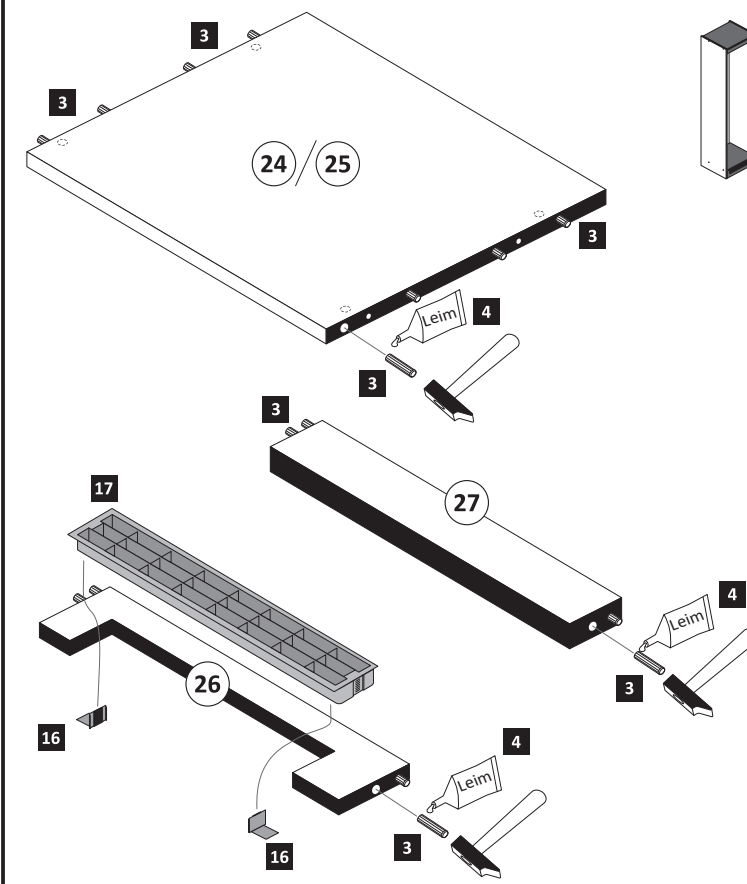

3

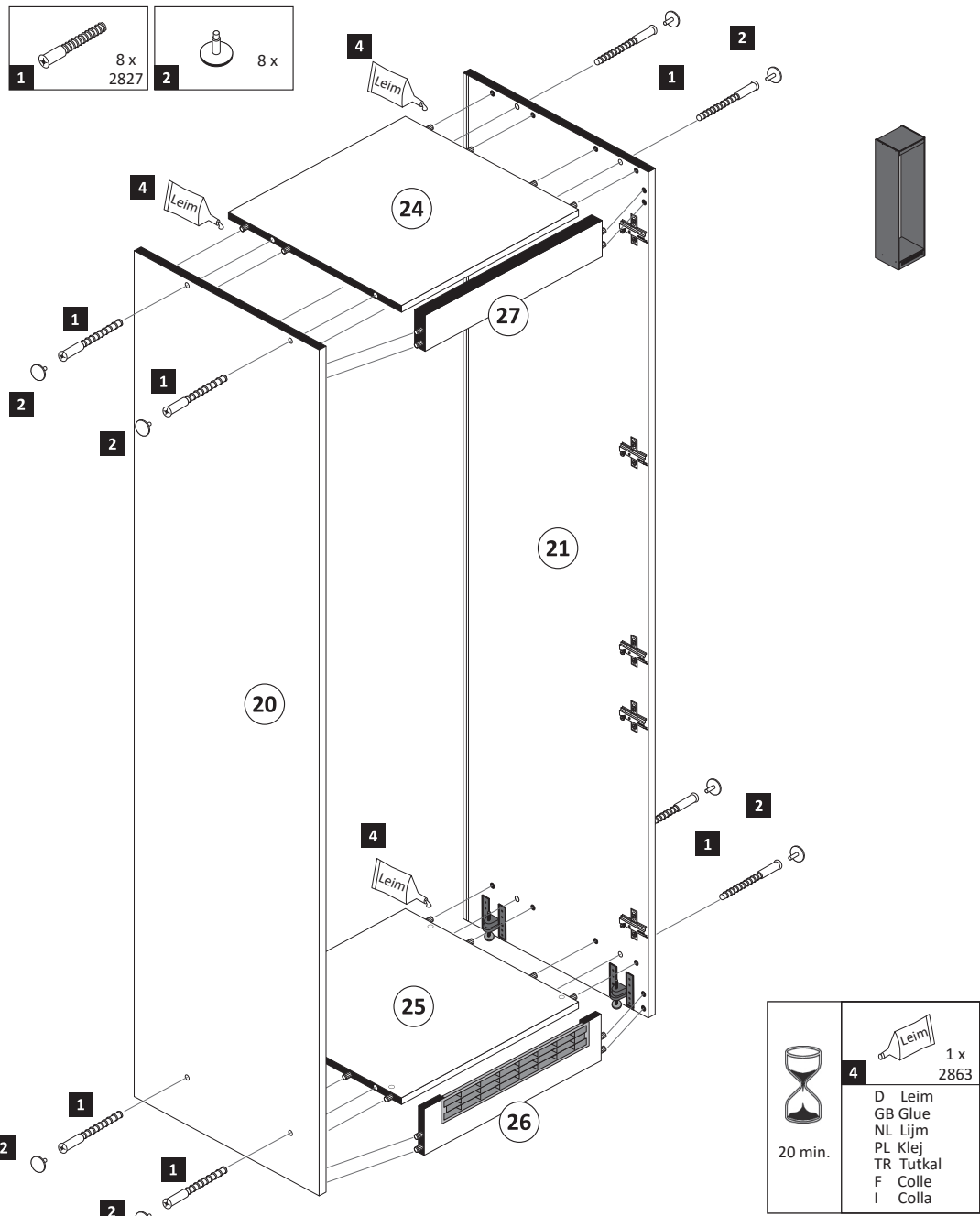

5

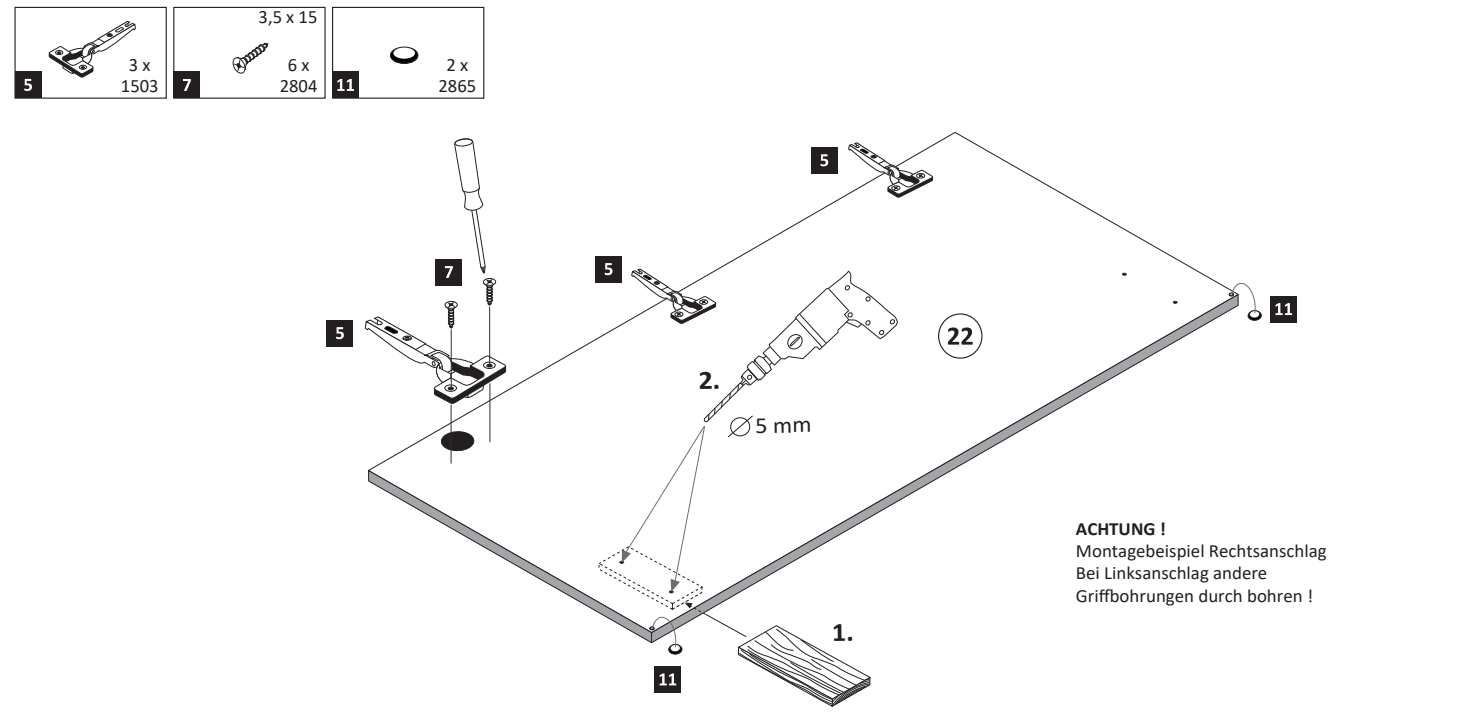

4

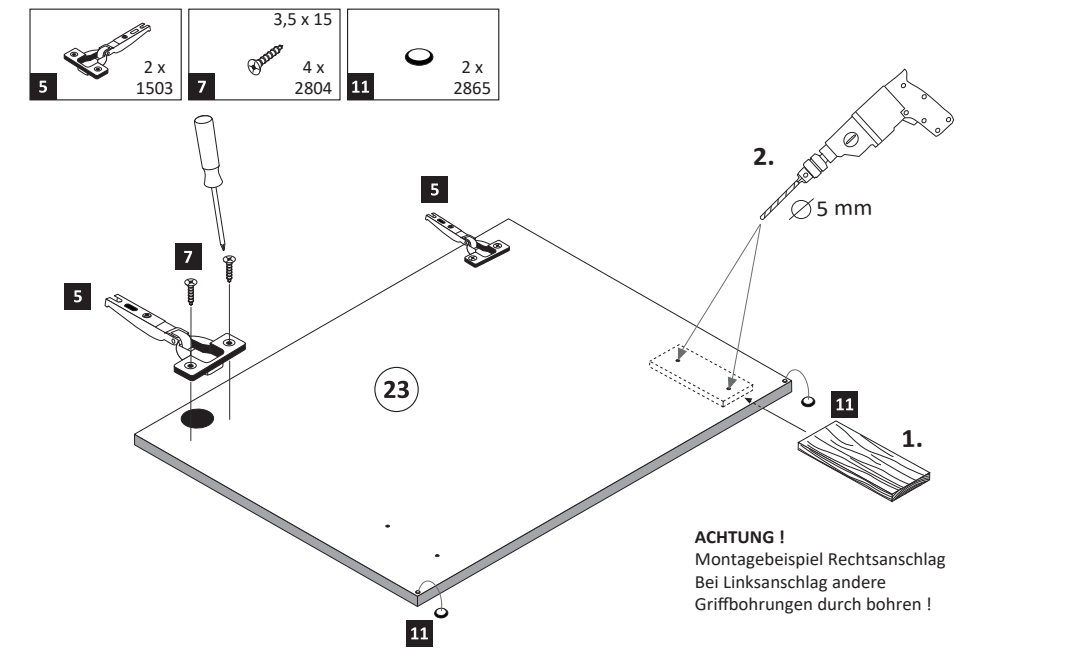

6

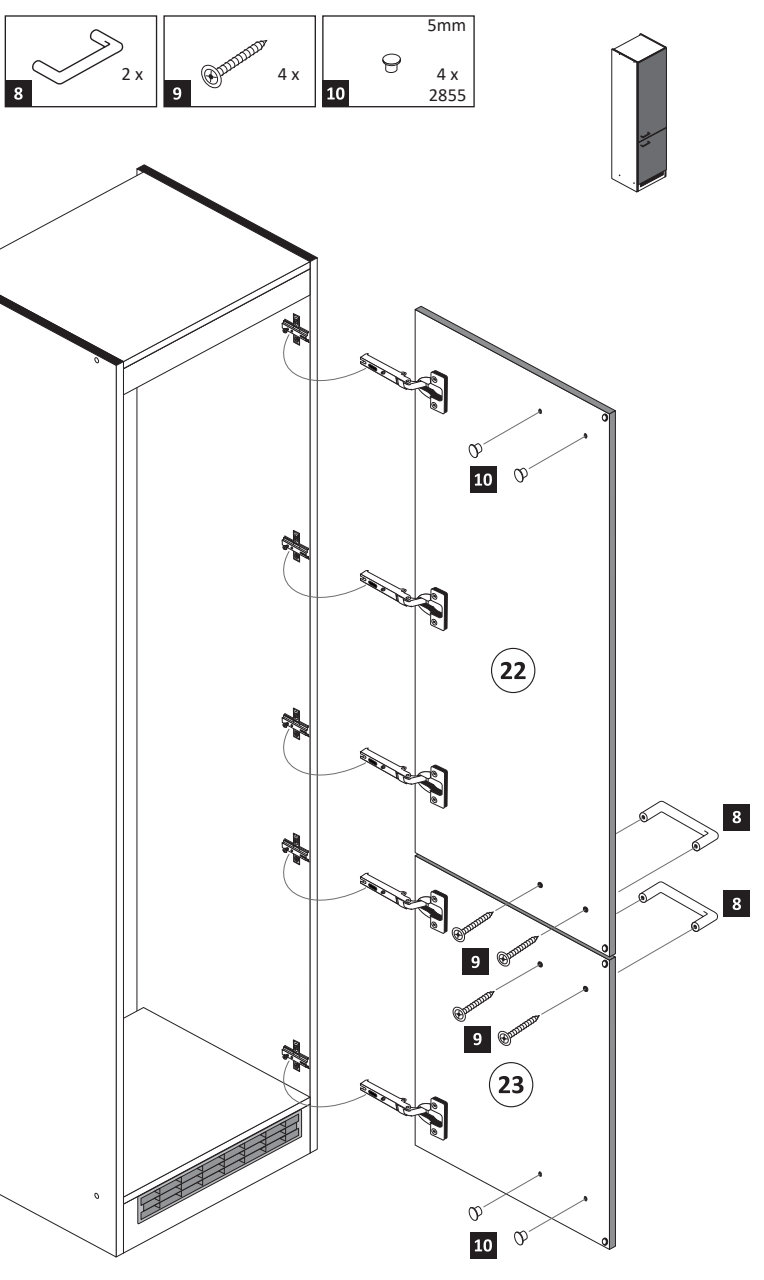

7

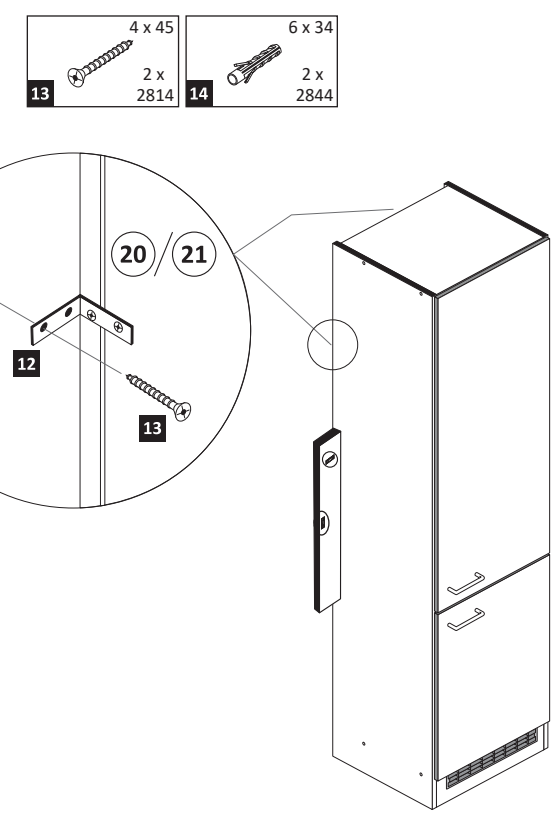

8

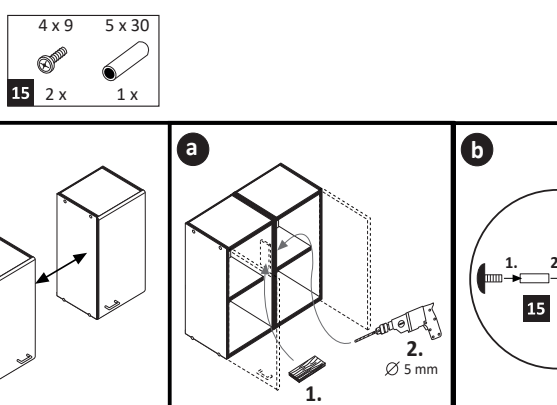

www.till-hilft.de



89930.330

 4 x 1980	 3,5 x 15 16 x 2804	 8mm 4 x 2917
---	--	--

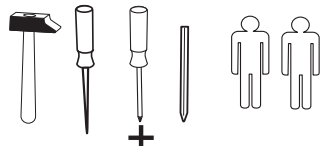
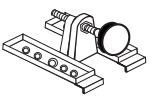

!! WICHTIG!!

Bitte fixieren den Schrank an der Wand bzw. an dem Nachbarschrank erst nach dem die Höheneinstellung mit dem Füßen durchgeführt ist.

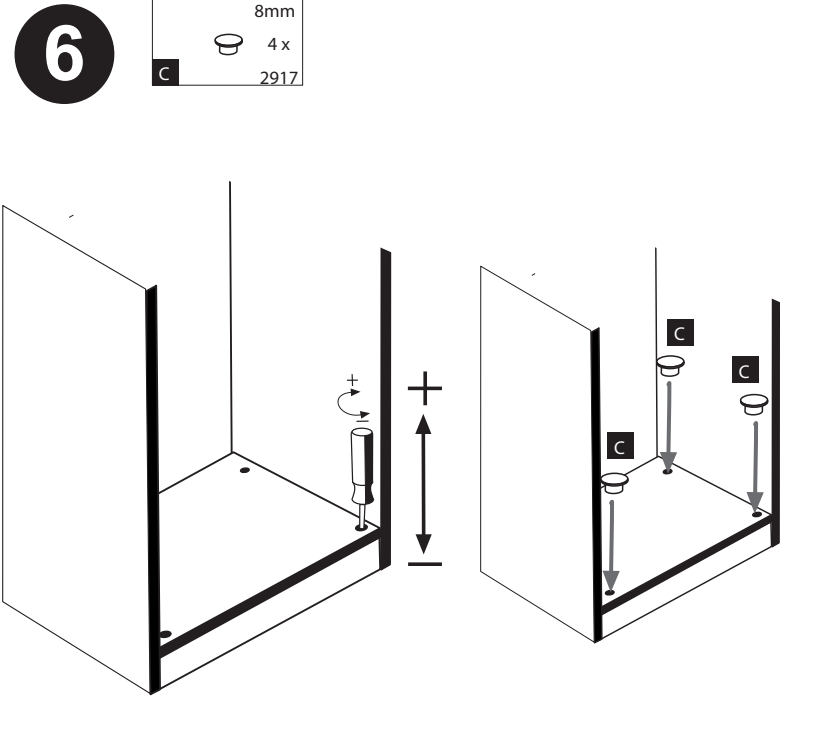
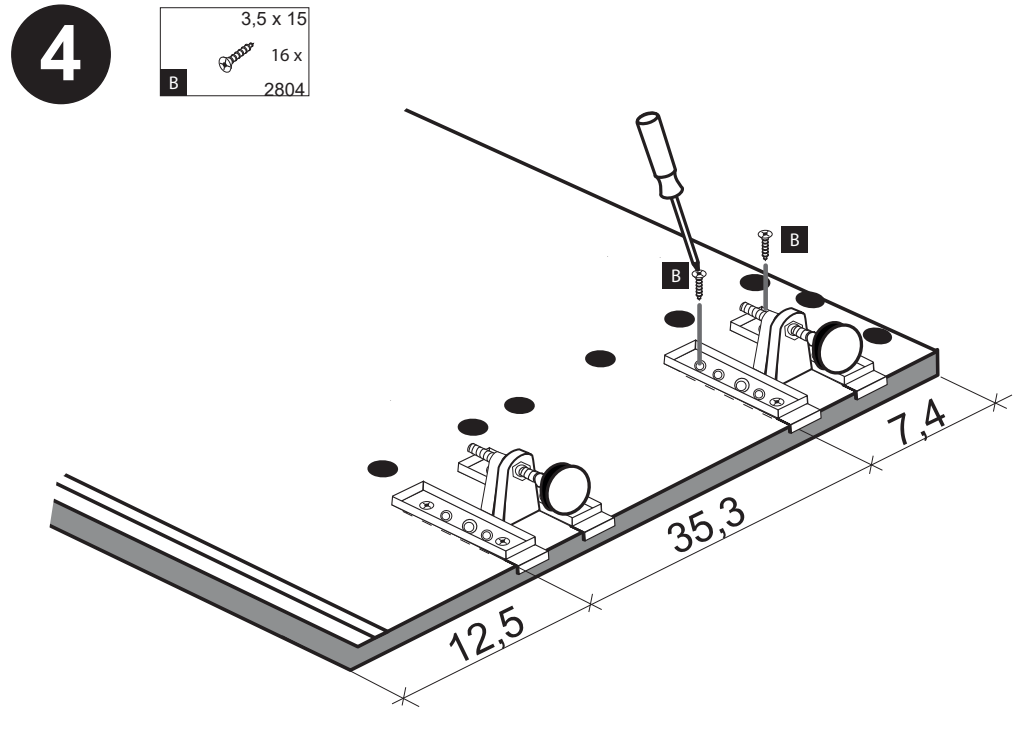
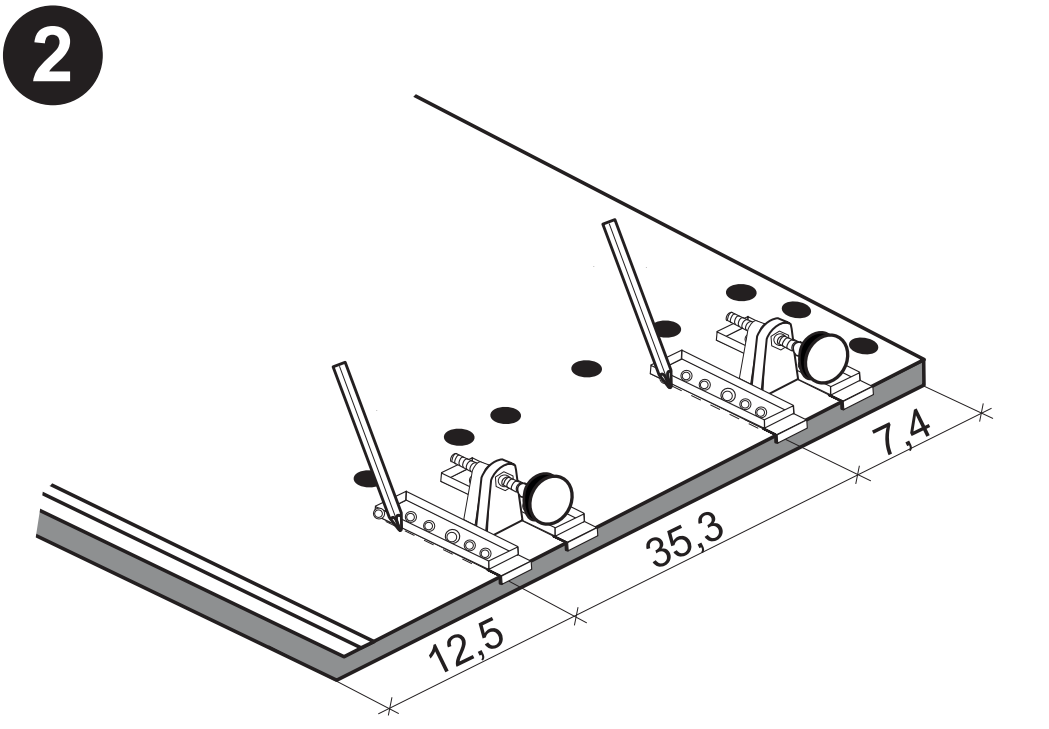
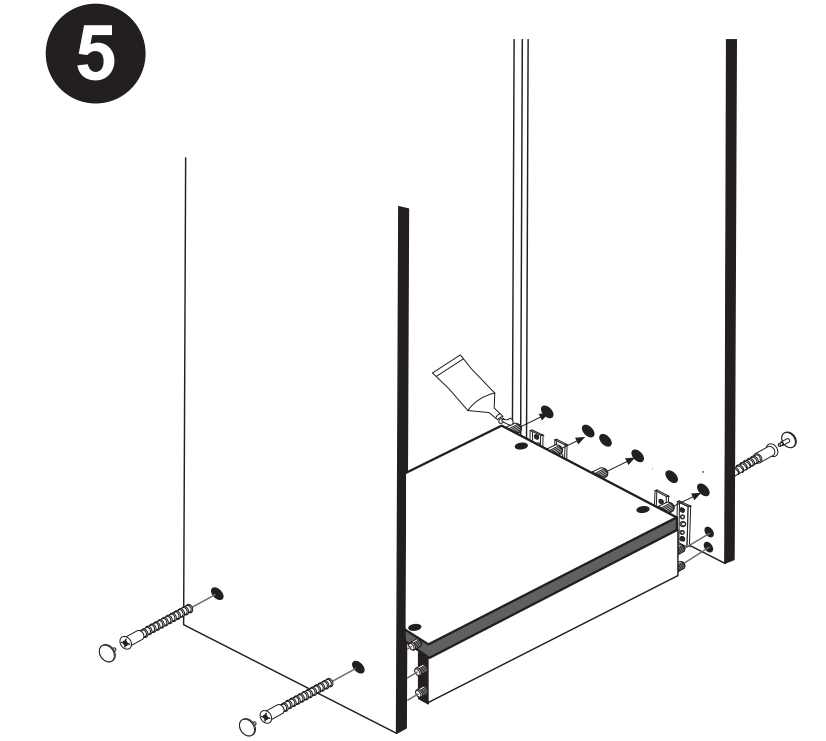
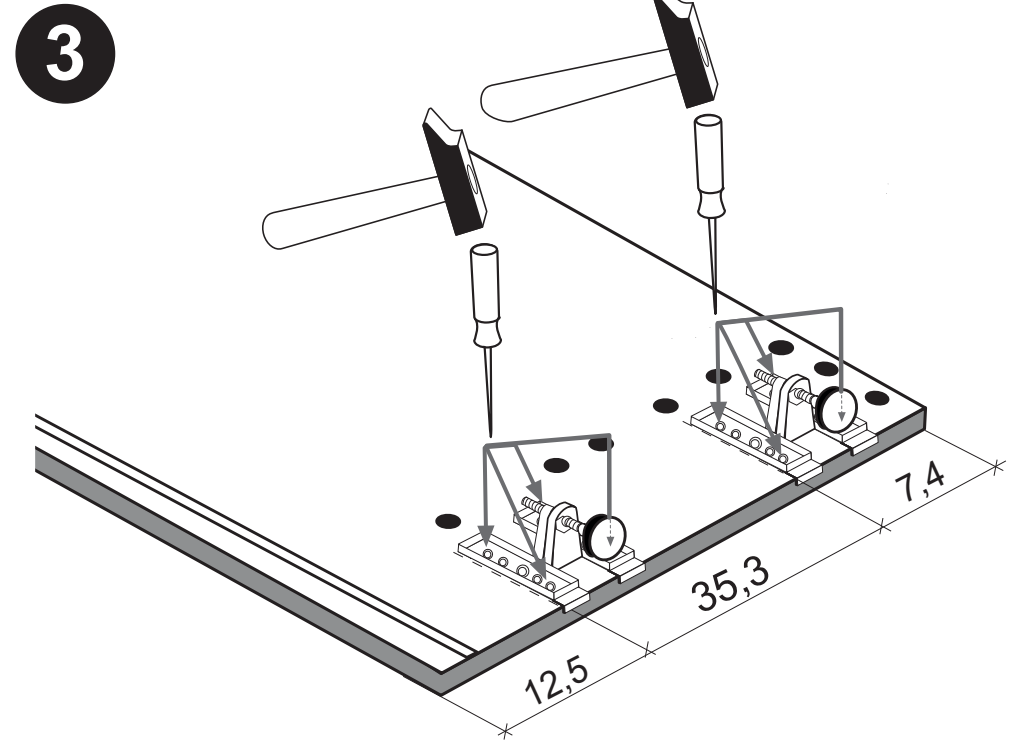
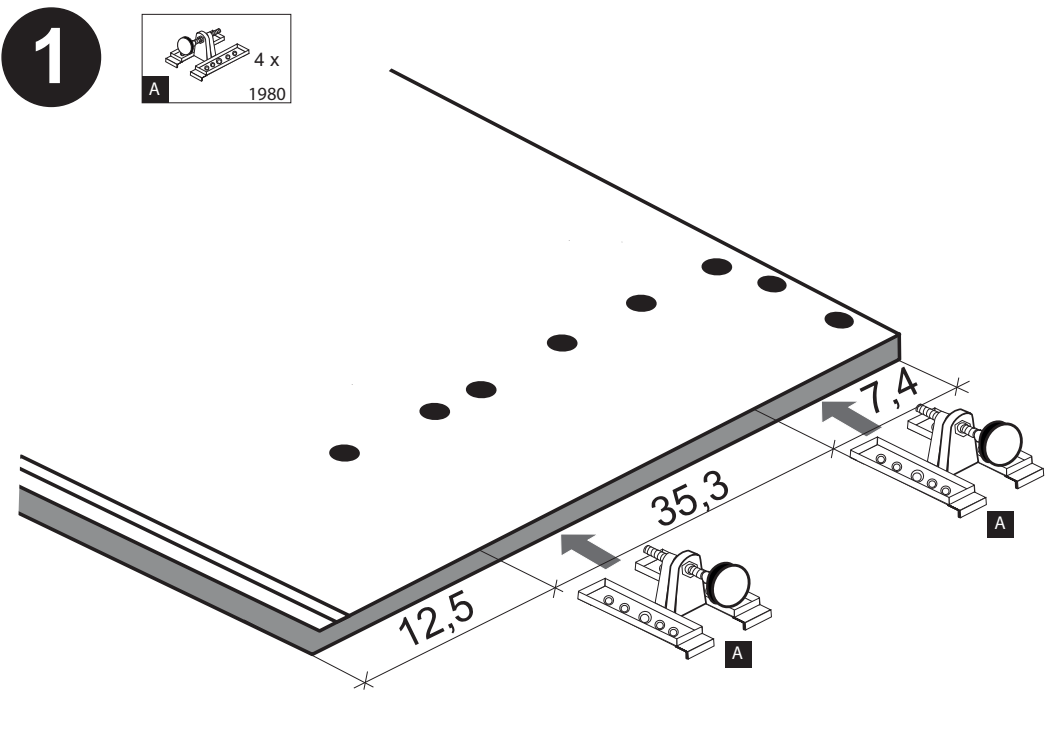



87265.312

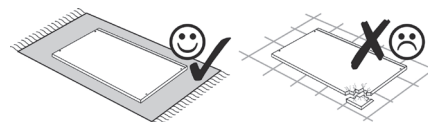
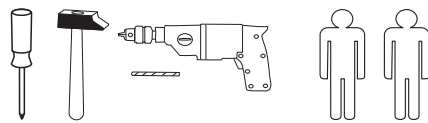
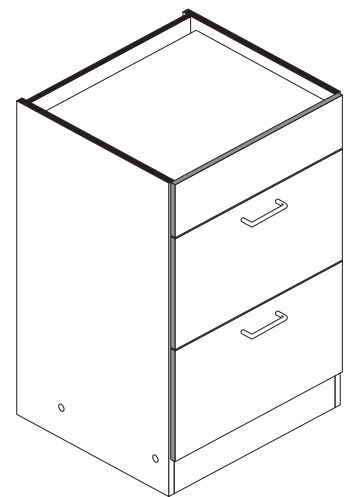

- | | | | | | |
|------------------------------|-------------------------------|-------------------------|----------------------------------|----------------------------------|-------------------------------|
| 1
4 x
2827 | 2
8 x 30
16 x
2861 | 3
2 x | 4
4 x | 5
4 x | 6
6,3 x 11
14 x
2815 |
| 7
6,3 x 16
2 x
2816 | 8
5/5 x 16
4 x
2821 | 9
4 x 9
2 x | 10
5 x 30
1 x | 11
25 x
2862 | 12
4 x
2865 |
| 13
4 x
5352.400 | 14
4 x | 15
2 x
2845 | 16
2 x R
2 x L
5282.400 | 17
2 x L
2 x R
5282.400 | 31
8 x
1123 |
| A
4 x
1980 | B
3,5 x 15
16 x
2804 | C
8mm
4 x
2917 | 0 10 20 30 40 | | |

Das beigelegte Wandbefestigungsmaterial (Dübel und Schrauben) eignet sich nur für festes Mauerwerk (z.B.: Beton- oder Ziegelwände). Für andere Wandaufbauten sind eventuell Spezialdübel und andere Schrauben notwendig. Ziehen Sie gegebenenfalls eine Fachkraft zu Rate.

De begeleidende wandmontage hardware (pluggen en schroeven) is alleen geschikt voor massief metselwerk (bijvoorbeeld beton of bakstenen muren). Voor andere muur structuren zijn eventueel bijzondere ankerbouten en andere noodzakelijke. Draai indien nodig, een deskundige.

Приложенный материал для крепления к стене (дюбели и винты) пригоден только для жестких кладок (например, бетонные или кирпичные стены). Для других настенных конструкций необходимы смотря по обстоятельствам специальные дюбели и другие винты. При необходимости проконсультируйтесь у специалиста.

Le mur d'accompagnement matériel de montage (chevilles et les vis) ne convient que pour la maçonnerie solide (par exemple en béton ou des murs de briques). Pour les structures de mur d'autres sont peut-être spéciale boulons d'ancrage et d'autres nécessaires. Serrer le cas échéant, un expert.

Zalączony materiał do mocowania do ściany (kolki rozprężne i wkręty) nadaje się tylko do ścian murowanych (np. z betonu lub cegiel). Do ścian wykonanych w innych technologiach konieczne być mogą specjalne kolki rozprężne i inne wkręty. W razie potrzeby skorzystaj z fachowej pomocy

Il muro di accompagnamento hardware di montaggio (tasselli e viti) è'e adatto solo per muratura piena (ad esempio calcestruzzo o muratura). Per le altre strutture murarie sono forse speciali bulloni di ancoraggio e necessari di altri. Serrare se necessario, un esperto.

The accompanying wall mounting hardware (anchors and screws) is suitable only for solid masonry (eg concrete or brick walls). For other wall structures are possibly special anchor bolts and other necessary. Tighten if necessary, an expert.

Ekteki duvarar sabit montaj malzemeleri (dübel ve vidalar), sadece sağlam duvarlar için (örnek: beton veya tuğla) elverişlidir. Başka duvarlar için özel dübeller ve farklı vidalar gerekebilir. Gerekliğinde bir uzmana danışınız.

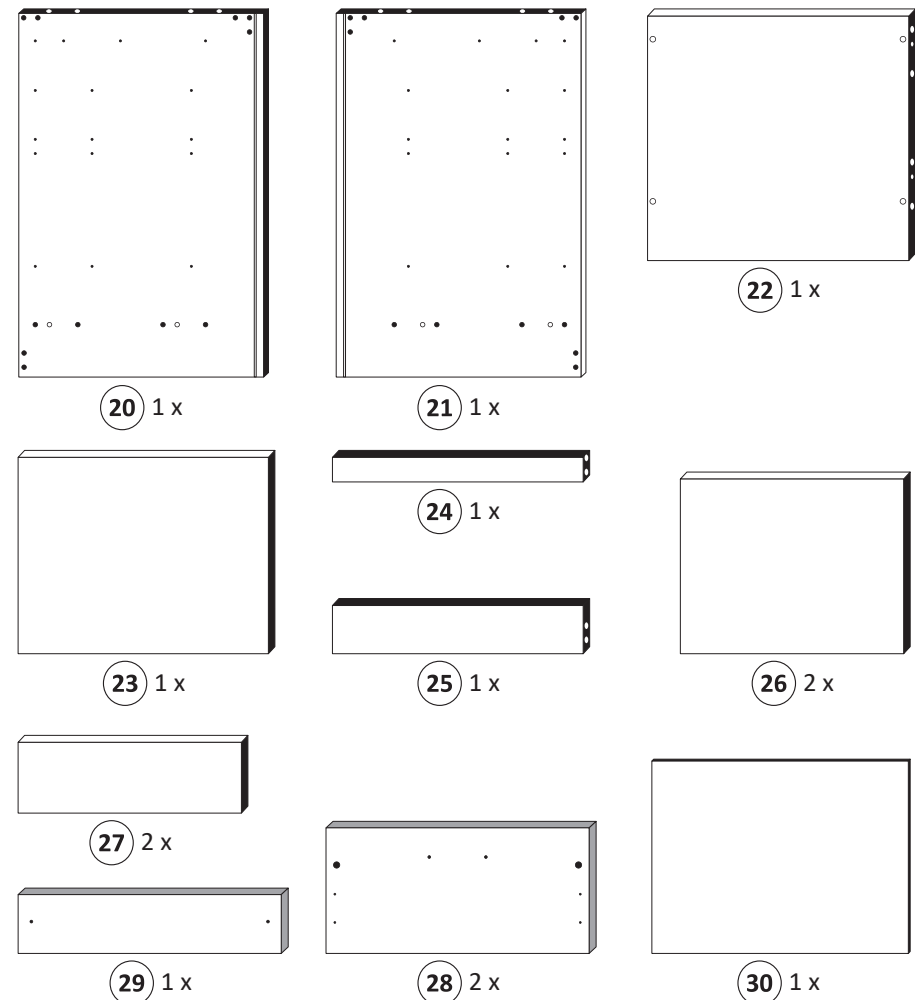

1

- | | | | | | | | |
|-------------------------------|------------------------------|---------------------------|-------------------|----------------------------------|-------------------------------|------------------|-------------------------------|
| 6
6,3 x 11
14 x
2815 | 8
5/5 x 16
4 x
2821 | 12
Leim
1 x
2863 | 15
2 x
2845 | 16
2 x R
2 x L
5282.400 | 18
3,5 x 15
2 x
2804 | A
4 x
1980 | B
3,5 x 15
16 x
2804 |
|-------------------------------|------------------------------|---------------------------|-------------------|----------------------------------|-------------------------------|------------------|-------------------------------|

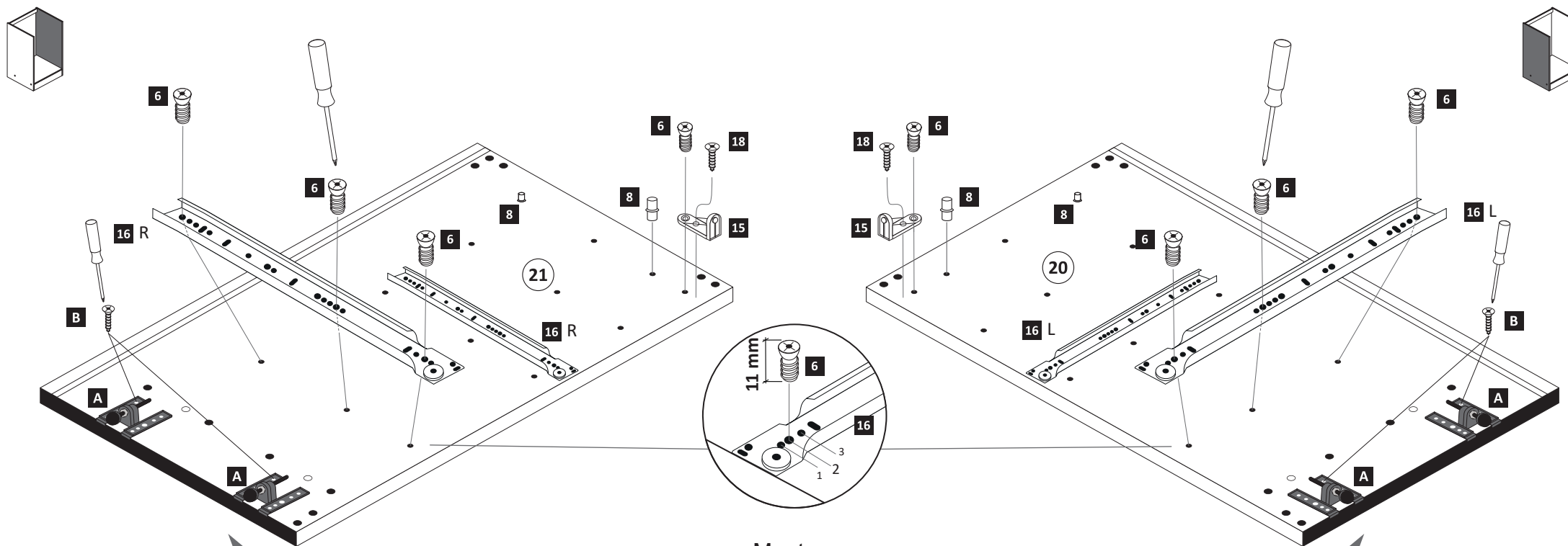

Montage
Zusatzteil Küchen
Unterbau-Fuß

2

- | | |
|-----------------------------|---------------------------|
| 2
8 x 30
16 x
2861 | 12
Leim
1 x
2863 |
|-----------------------------|---------------------------|

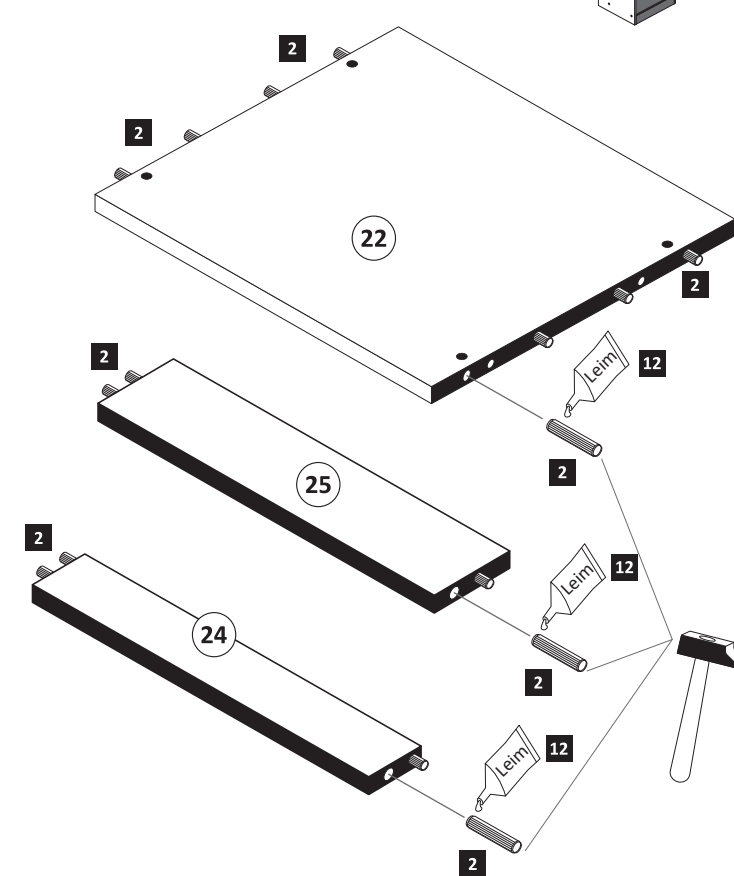

3

1 4 x 2827 5 4 x 7 6,3 x 16 2 x 2816

12 Leim

20 21 22 23 24 25 29

12	Leim	1 x 2863
	D Leim	
	GB Glue	
	NL Lijm	
	PL Klej	
	TR Tutkal	
	F Colle	
	I Colla	

20 min.

5

23

7

17 2 x L 2 x R 5282.400

17.1

4x

1. Schraube leicht lösen.

2. Zargenseite von Frontverbinder trennen.

8

13 4 x 5352.400

13.1

1. 2. 3.

4

10 10 x 2862

30

6

28 2x

1. 2. 5 mm

9

11 4 x 2865 31 3 x 13,5 8 x 1123

11 13.1 17.1 28 2x

- 10** 14 4 x 18 3,5 x 15 8 x 2804

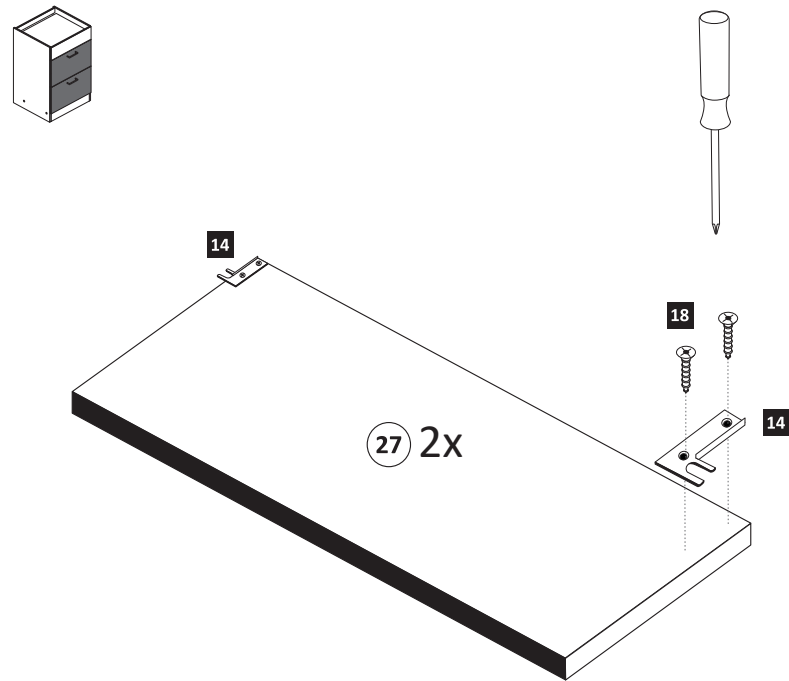

- 12**

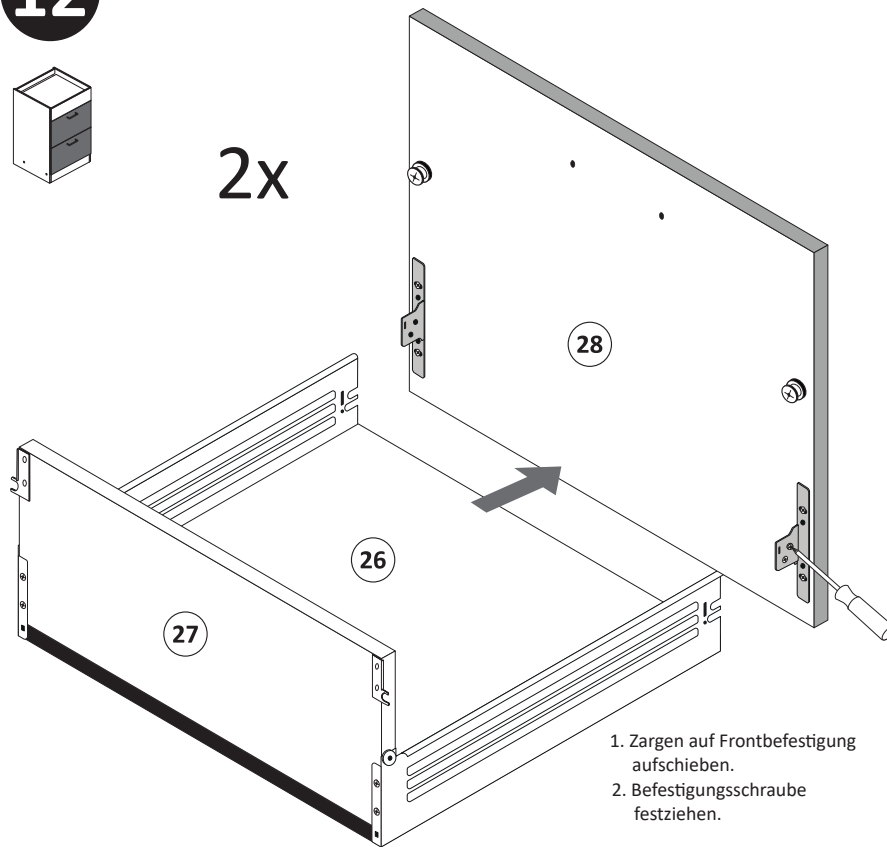

- 14**

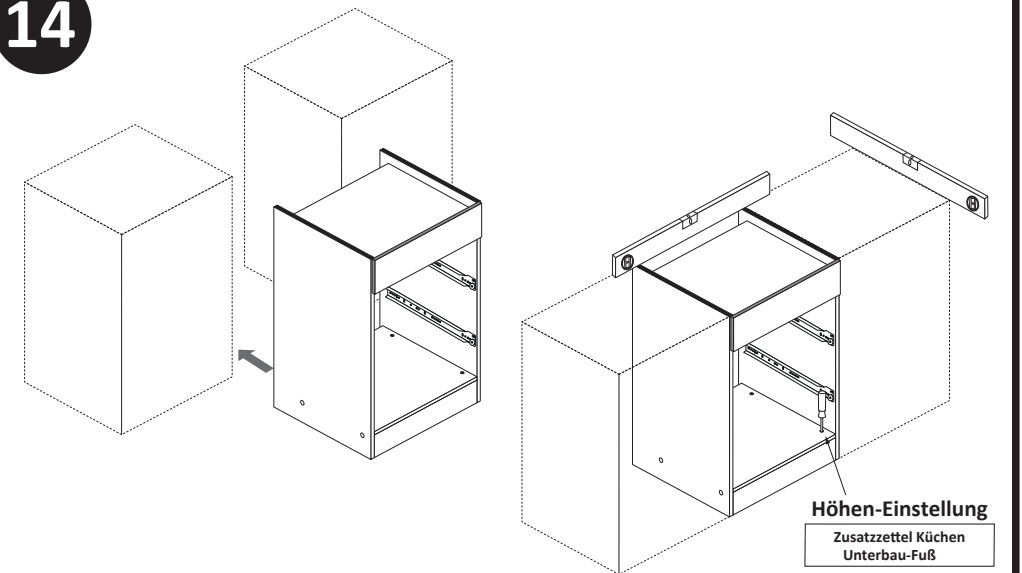

- 15**

- 4 x 9 5 x 30
9 2 x 1 x

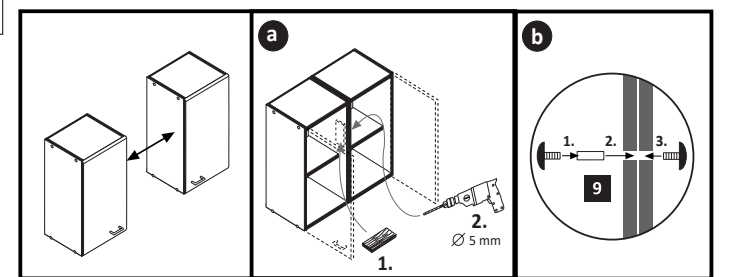

- 11**

- 17 2 x L 2 x R 5282.400 18 3,5 x 15 16 x 2804

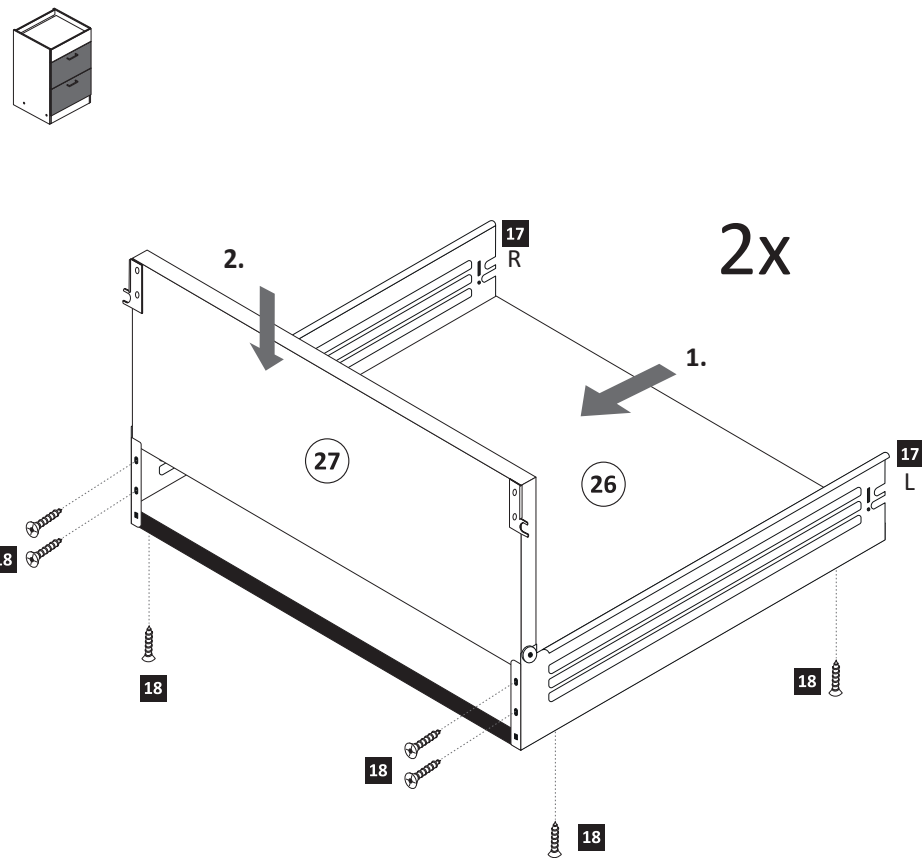

- 13**

- 3 2 x 4 M4 4 x

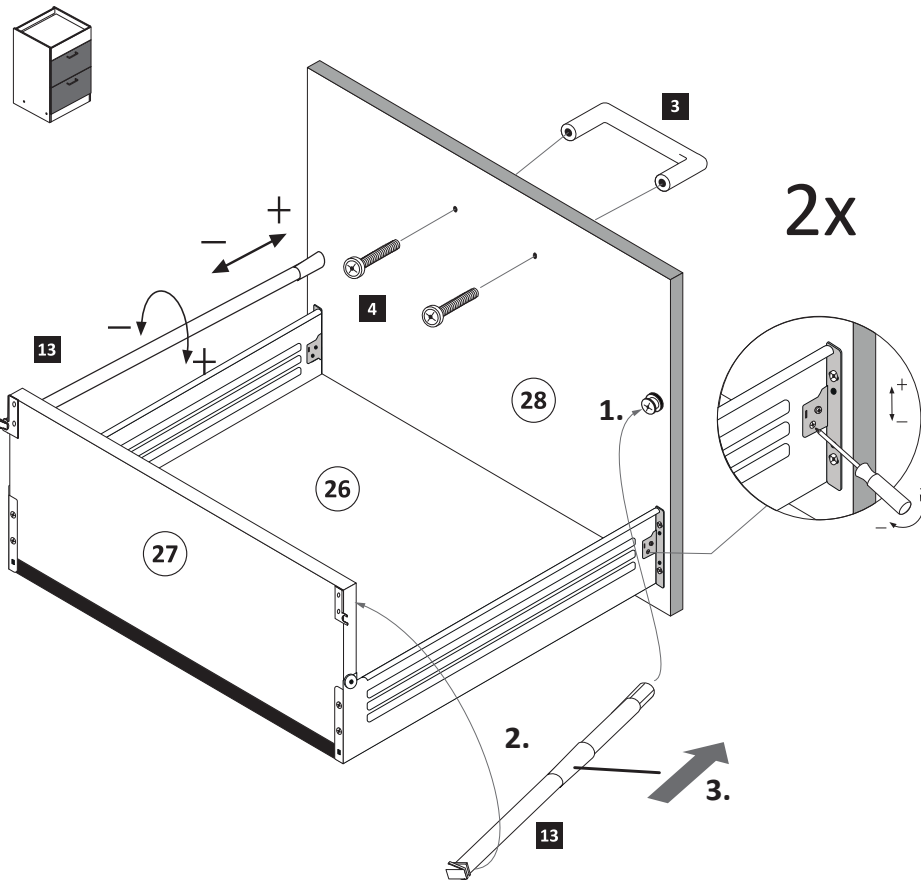

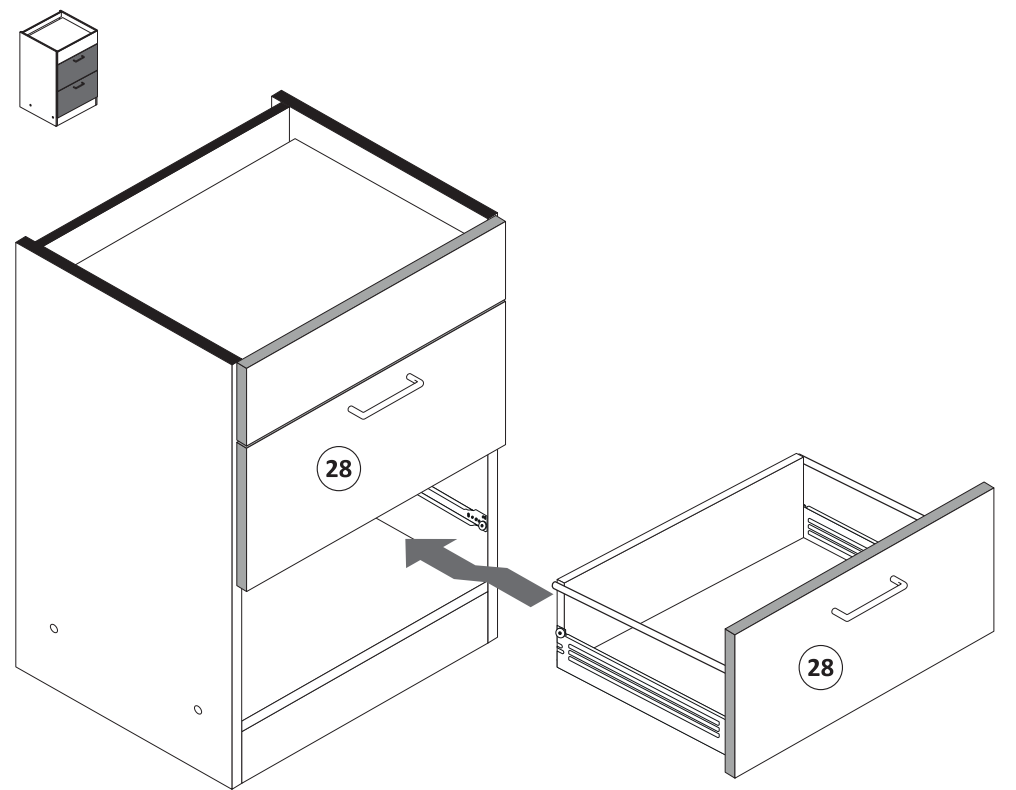

- 16**



www.till-hilft.de

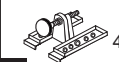

89930.330

 4 x 1980	 3,5 x 15 16 x 2804	 8mm 4 x 2917
---	--	--

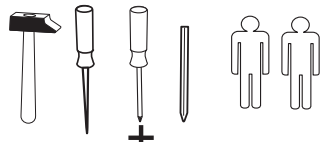
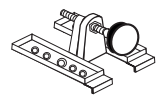
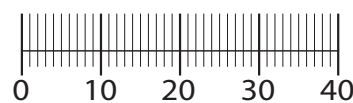

!! WICHTIG!!

Bitte fixieren den Schrank an der Wand bzw. an dem Nachbarschrank erst nach dem die Höheneinstellung mit dem Füßen durchgeführt ist.

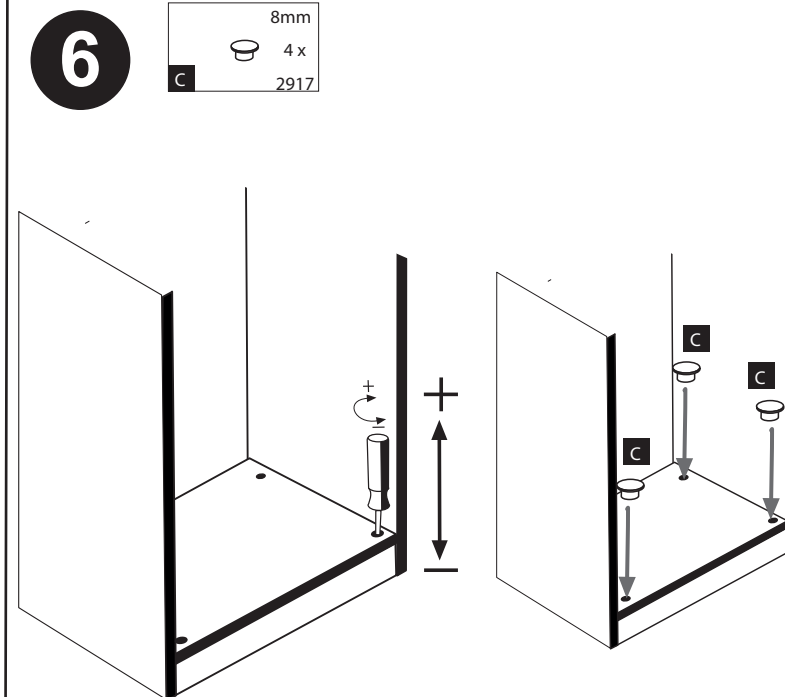
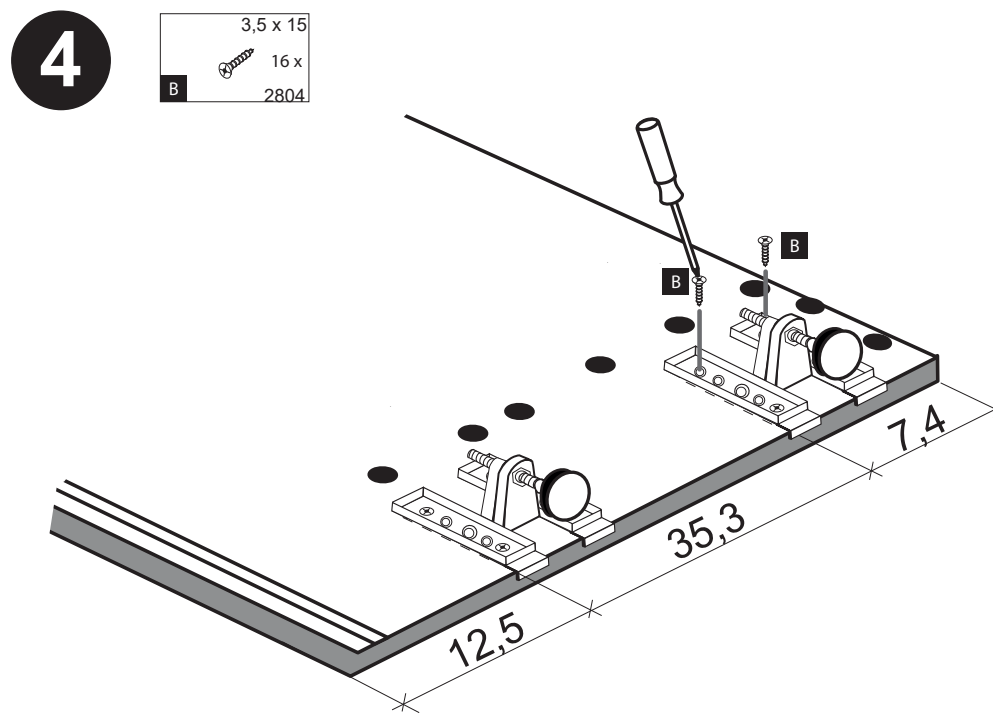
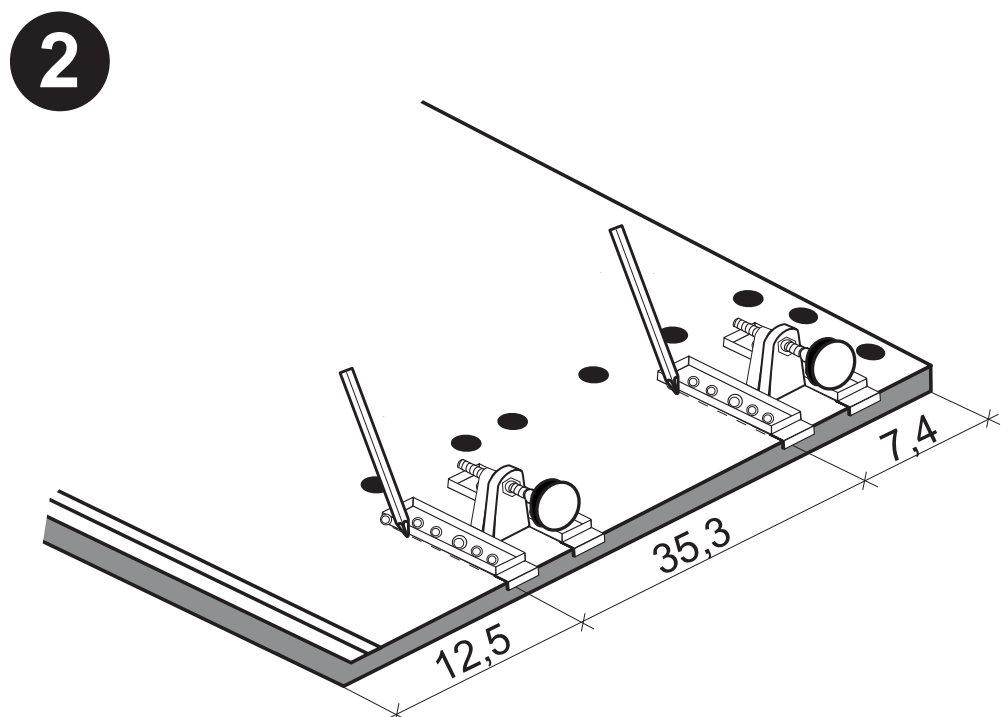
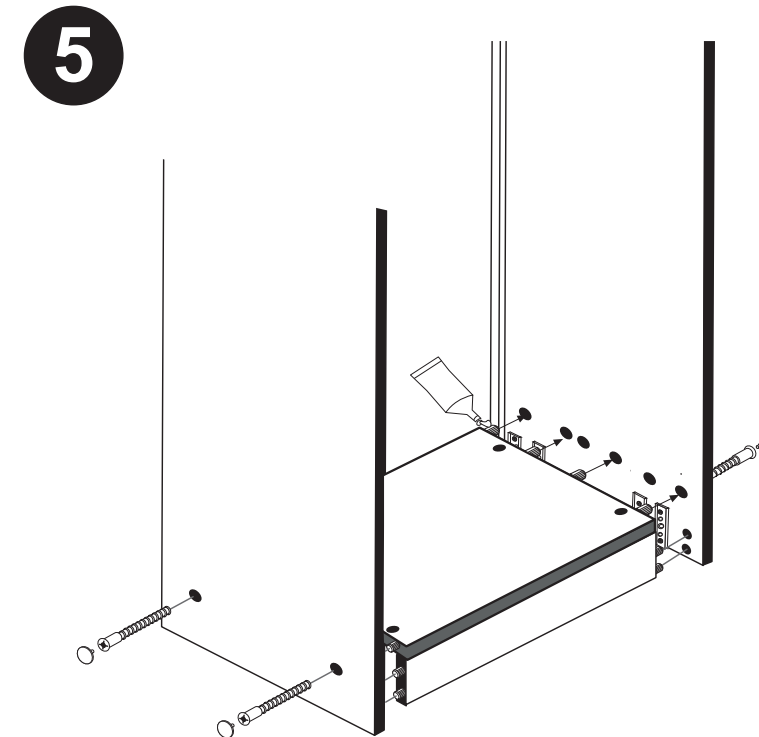
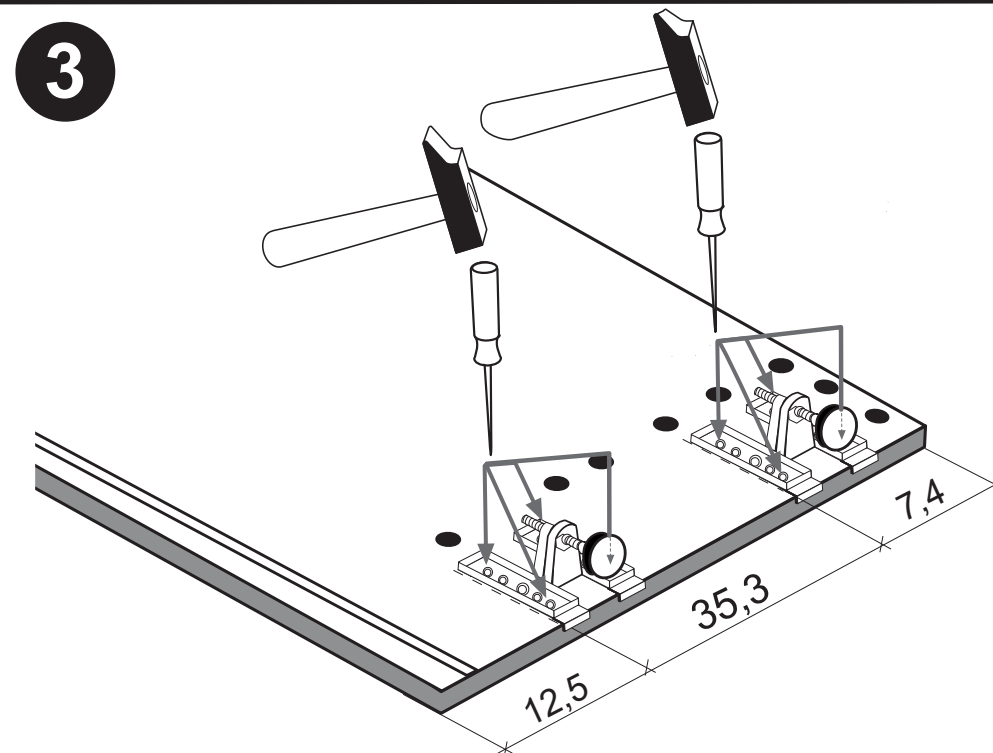
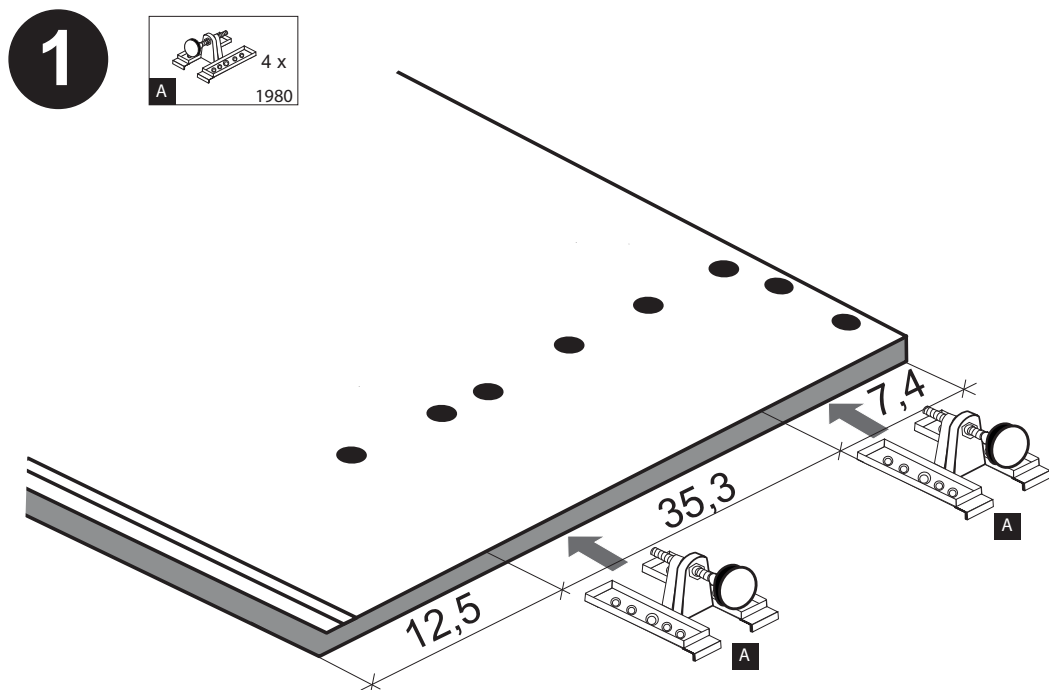

**D****Wichtige Pflegehinweise**

Bitte beachten Sie die wichtigen Pflegehinweise auf unserer Internetseite

www.till-hilft.de

Pflegehinweise

**PL****Ważne instrukcje dotyczące pielęgnacji**

Zwróć uwagę na ważną instrukcję dotyczącą pielęgnacji na naszej stronie internetowej

www.till-hilft.de

Pflegehinweise

**GB****Important care instructions**

Please note the important care instructions on our website

www.till-hilft.de

Pflegehinweise

**SK****Dôležité pokyny na starostlivosť**

Dbajte na dôležité pokyny týkajúce sa starostlivosti na našich webových stránkach

www.till-hilft.de

Pflegehinweise

**FR****Instructions d'entretien importantes**

S'il vous plaît noter les instructions de soins importants sur notre site Web

www.till-hilft.de

Pflegehinweise

**HU****Fontos kezelési utasítások**

Kérjük, vegye figyelembe a honlapunkon található fontos kezelési útmutatót

www.till-hilft.de

Pflegehinweise

**IT****Importanti istruzioni per la cura**

Si prega di notare le importanti istruzioni per la cura sul nostro sito web

www.till-hilft.de

Pflegehinweise

**RO****Instrucțiunile importante de îngrijire**

Rețineți instrucțiunile importante de îngrijire de pe site-ul nostru

www.till-hilft.de

Pflegehinweise

**NL****Belangrijke zorginstructies**

Let op de belangrijke zorginstructies op onze website

www.till-hilft.de

Pflegehinweise

**TR****Önemli bakım talimatları**

Lütfen web sitemizdeki önemli bakım talimatlarını dikkate alınız

www.till-hilft.de

Pflegehinweise

**CZ****Důležité pokyny pro péči**

Vezměte prosím na vědomí důležité pokyny pro péči na našich webových stránkách

www.till-hilft.de

Pflegehinweise

**RU****Важные инструкции по уходу**

Обратите внимание на важные инструкции по уходу на нашем веб-сайте

www.till-hilft.de

Pflegehinweise



www.till-hilft.de



89930.330

 4 x 1980	 3,5 x 15 16 x 2804	 8mm 4 x 2917
---	--	--



!! WICHTIG!!

Bitte fixieren den Schrank an der Wand bzw. an dem Nachbarschrank erst nach dem die Höheneinstellung mit dem Füßen durchgeführt ist.

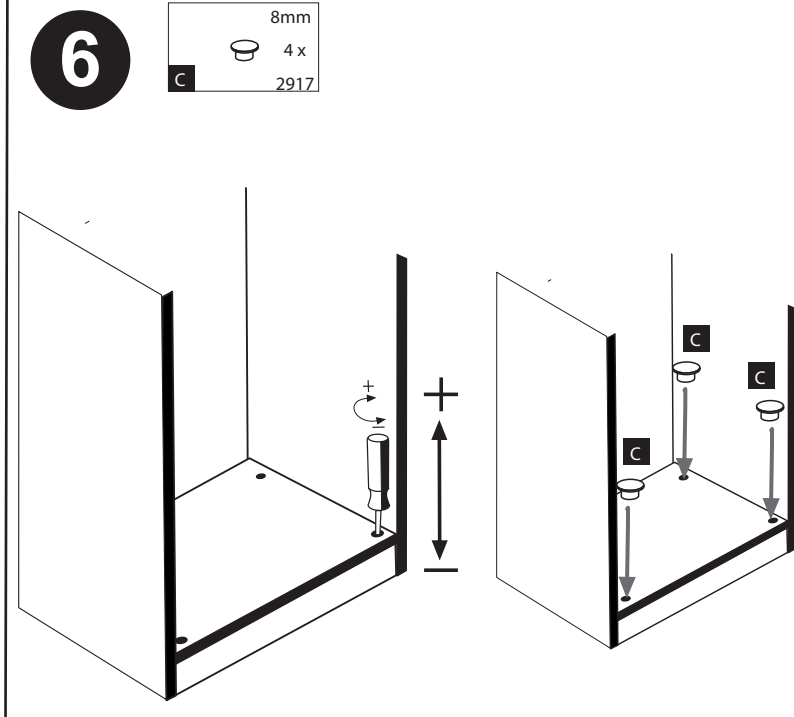
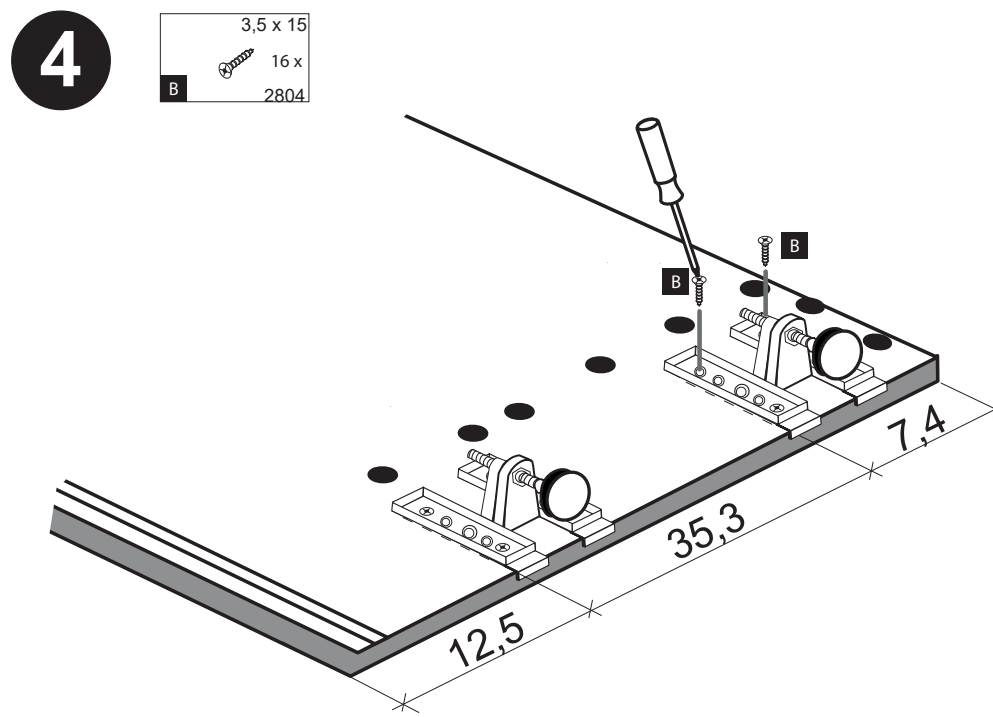
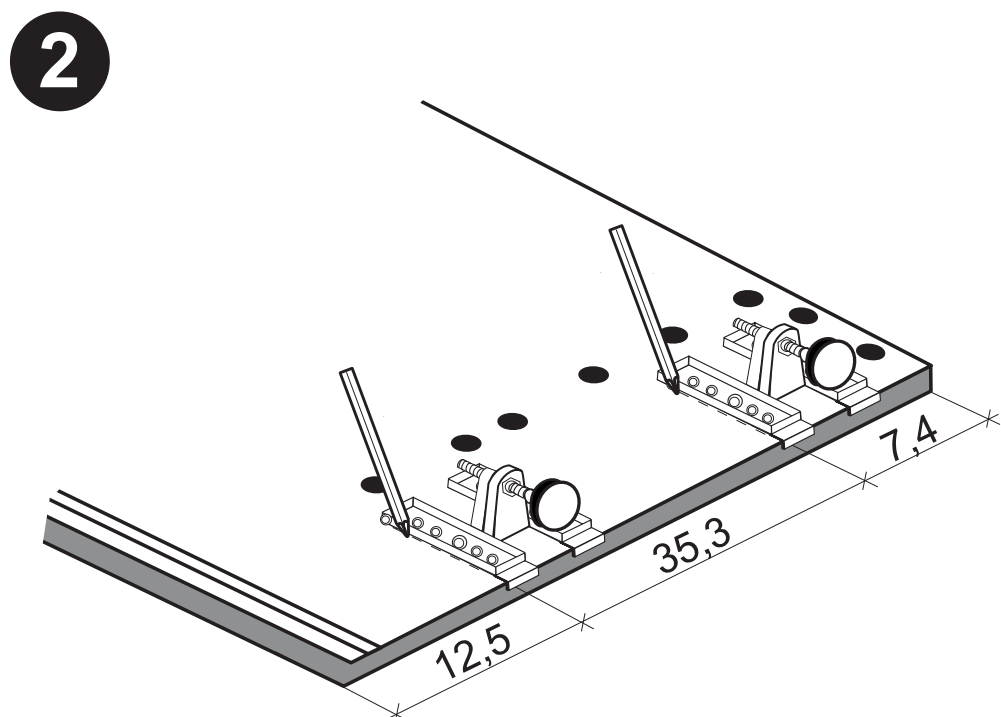
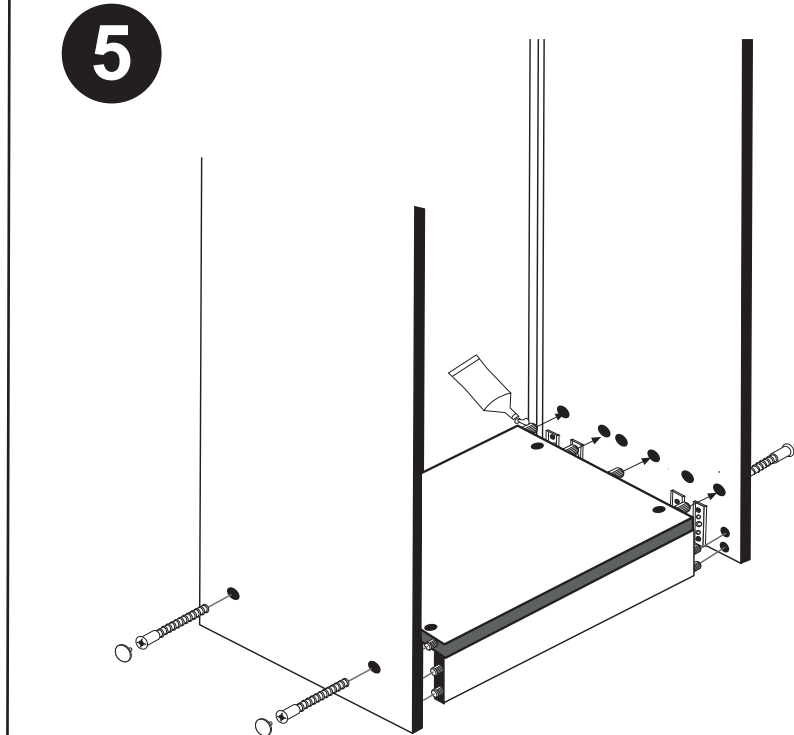
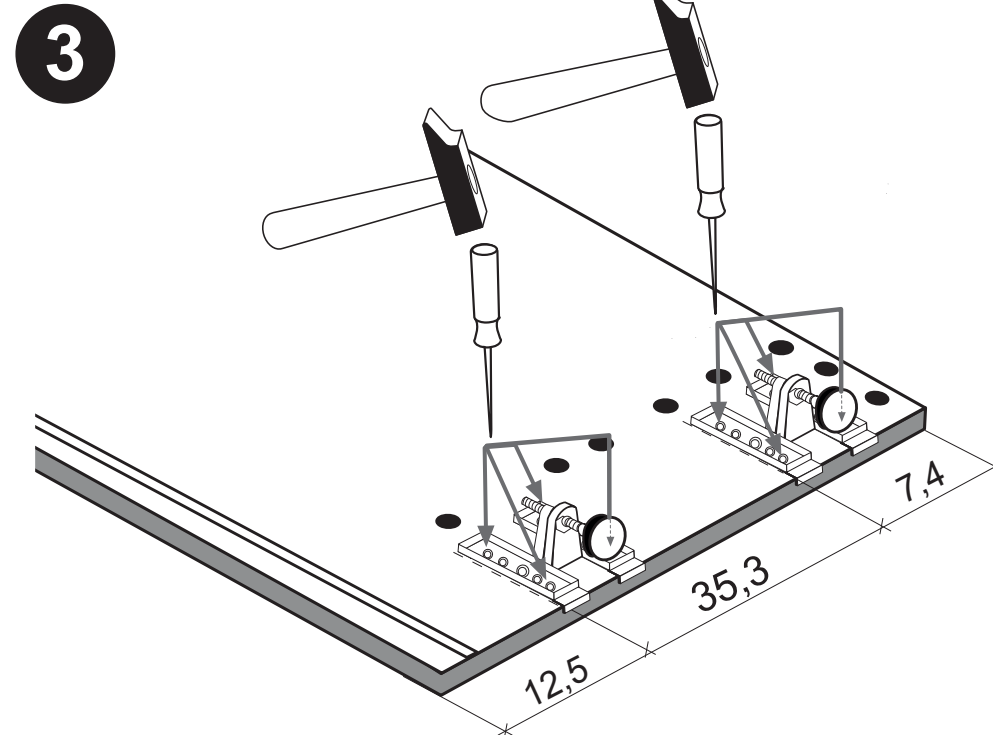
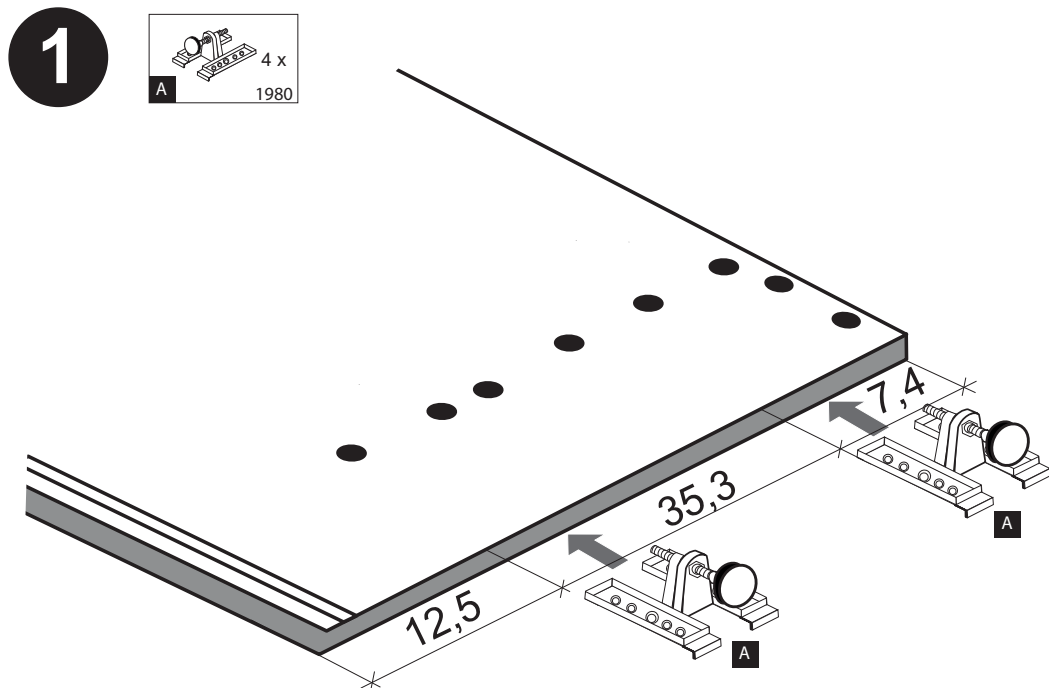



87239.730

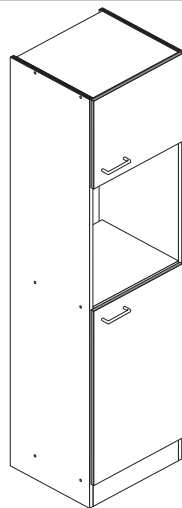

Variante A: ohne Kühlschrank

Variante B: mit Kühlschrank

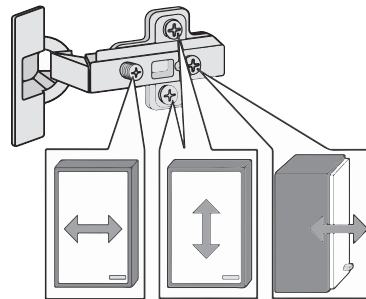
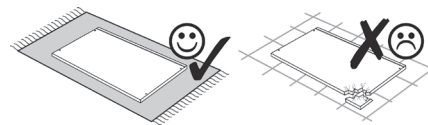
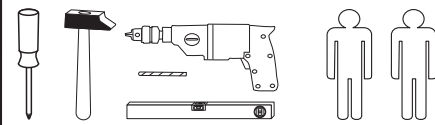

1 12 x 2827	2 12 x	3 8 x 30 36 x 2861	4 2 x 1611	5 2 x 1503
6 2 x 2863	7 3,5 x 15 8 x 2804	8 2 x	9 4 x	10 5mm 4 x 2855
11 4 x 2865	12 25 x 2862	13 1 x 2845	14 6 x 34 1 x 2844	15 4 x 45 1 x 2814
16 3,5 x 15 1 x 2804	17 4 x 15 1 x 2810	18 4 x 9 5 x 30 2 x 1 x	19 4 x 1613	20 gedämpft 4 x 1504
21 optional 35 mm 4 x 2886	22 5/5 x 16 8 x 2821	A 4 x 1980	B 3,5 x 15 16 x 2804	C 8mm 4 x 2917

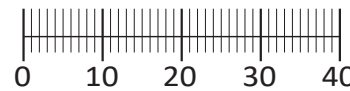

Das beigefügte Wandbefestigungsmaterial (Dübel und Schrauben) eignet sich nur für festes Mauerwerk (z.B.: Beton- oder Ziegelwände). Für andere Wandaufbauten sind eventuell Spezialdübel und andere Schrauben notwendig. Ziehen Sie gegebenenfalls eine Fachkraft zu Rate.

De begeleidende wandmontage hardware (pluggen en schroeven) is alleen geschikt voor massief metselwerk (bijvoorbeeld beton of bakstenen muren). Voor andere muur structuren zijn eventueel bijzondere ankerbouten en andere noodzakelijke. Draai indien nodig, een deskundige.

Приложенный материал для крепления к стене (дюбели и винты) пригоден только для жестких кладок (например, бетонные или кирпичные стены). Для других настенных конструкций необходимы смотря по обстоятельствам специальные дюбели и другие винты. При необходимости проконсультируйтесь у специалиста.

Le mur d'accompagnement matériel de montage (chevilles et les vis) ne convient que pour la maçonnerie solide (par exemple en béton ou des murs de briques). Pour les structures de mur d'autres sont peut-être spéciale boulons d'ancrage et d'autres nécessaires. Serrer le cas échéant, un expert.

Załączony materiał do mocowania do ściany (kolki rozprężne i wkręty) nadaje się tylko do ścian murowanych (np. z betonu lub cegiel). Do ścian wykonanych w innych technologiach konieczne być mogą specjalne kolki rozprężne i inne wkręty. W razie potrzeby skorzystaj z fachowej pomocy

Il muro di accompagnamento hardware di montaggio (tasselli e viti) è'e adatto solo per muratura piena (ad esempio calcestruzzo o muratura). Per le altre strutture murarie sono forse speciali bulloni di ancoraggio e necessari di altri. Serrare se necessario, un esperto.

The accompanying wall mounting hardware (anchors and screws) is suitable only for solid masonry (eg concrete or brick walls). For other wall structures are possibly special anchor bolts and other necessary. Tighten if necessary, an expert.

Ekteki duvara sabit montaj malzemeleri (dübel ve vidalar), sadece sağlam duvarlar için (örnek: beton veya tuğla) elverişlidir. Başka duvarlar için özel dübeller ve farklı vidalar gerekebilir. Gerektiğinde bir uzmana danışınız.

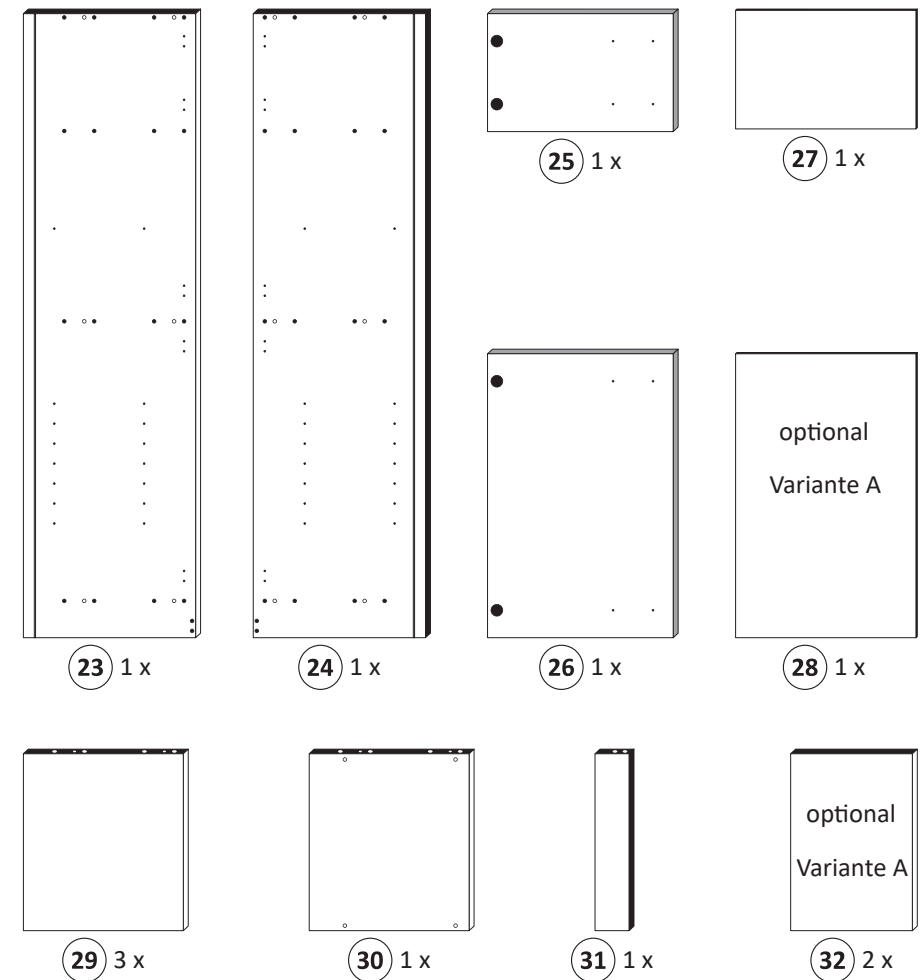

1 Variante A

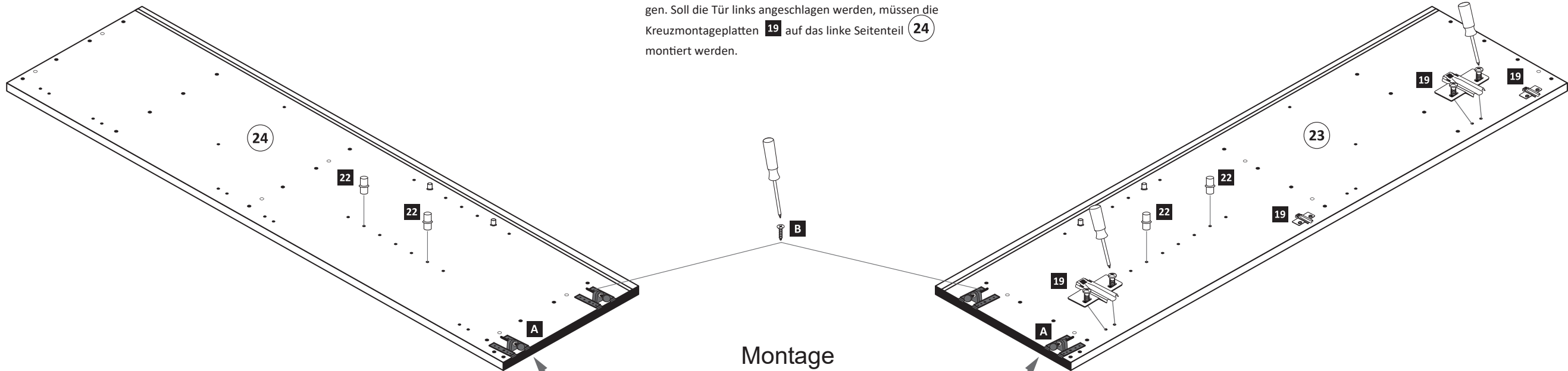

19 4 x 1613	22 5/5 x 16 8 x 2821	A 4 x 1980	B 3,5 x 15 16 x 2804
----------------	----------------------------	---------------	----------------------------

Bitte beachten !
In dieser Aufbauanleitung ist die Tür rechts angeschlagen. Soll die Tür links angeschlagen werden, müssen die Kreuzmontageplatten 19 auf das linke Seitenteil 24 montiert werden.

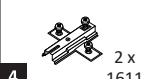

Montage
Zusatzzettel Küchen
Unterbau-Fuß

1 Variante B

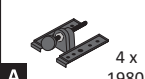
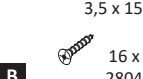
- | | | | |
|--|--|--|---|
|  2 x 1611 |  2 x 1613 |  4 x 1980 |  3,5 x 15
16 x 2804 |
|--|--|--|---|

Bitte beachten !

In dieser Aufbauanleitung ist die Tür rechts angeschlagen. Soll die Tür links angeschlagen werden, müssen die Kreuzmontageplatten **4** und **19** auf das linke Seitenteil **24** montiert werden.

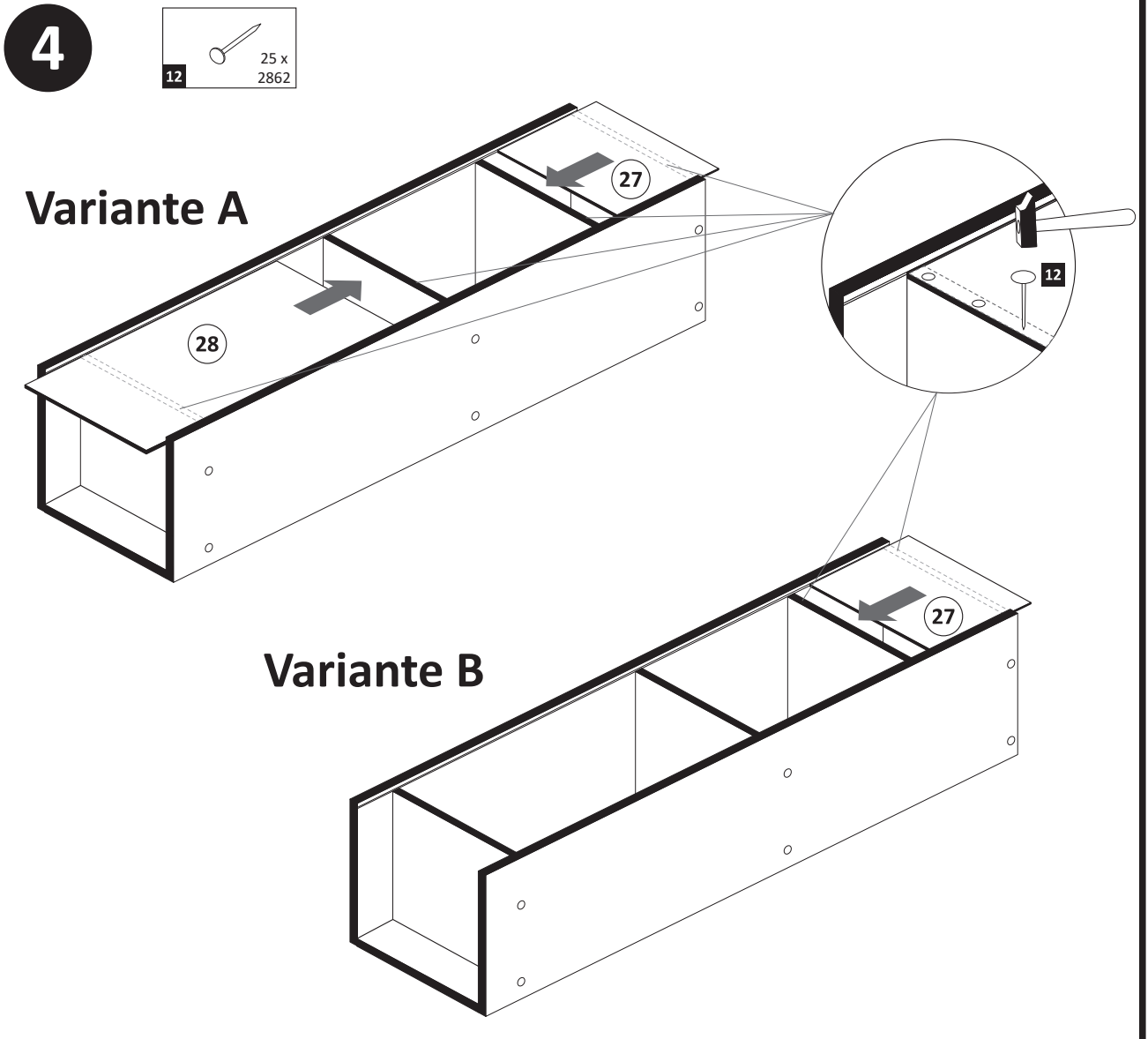
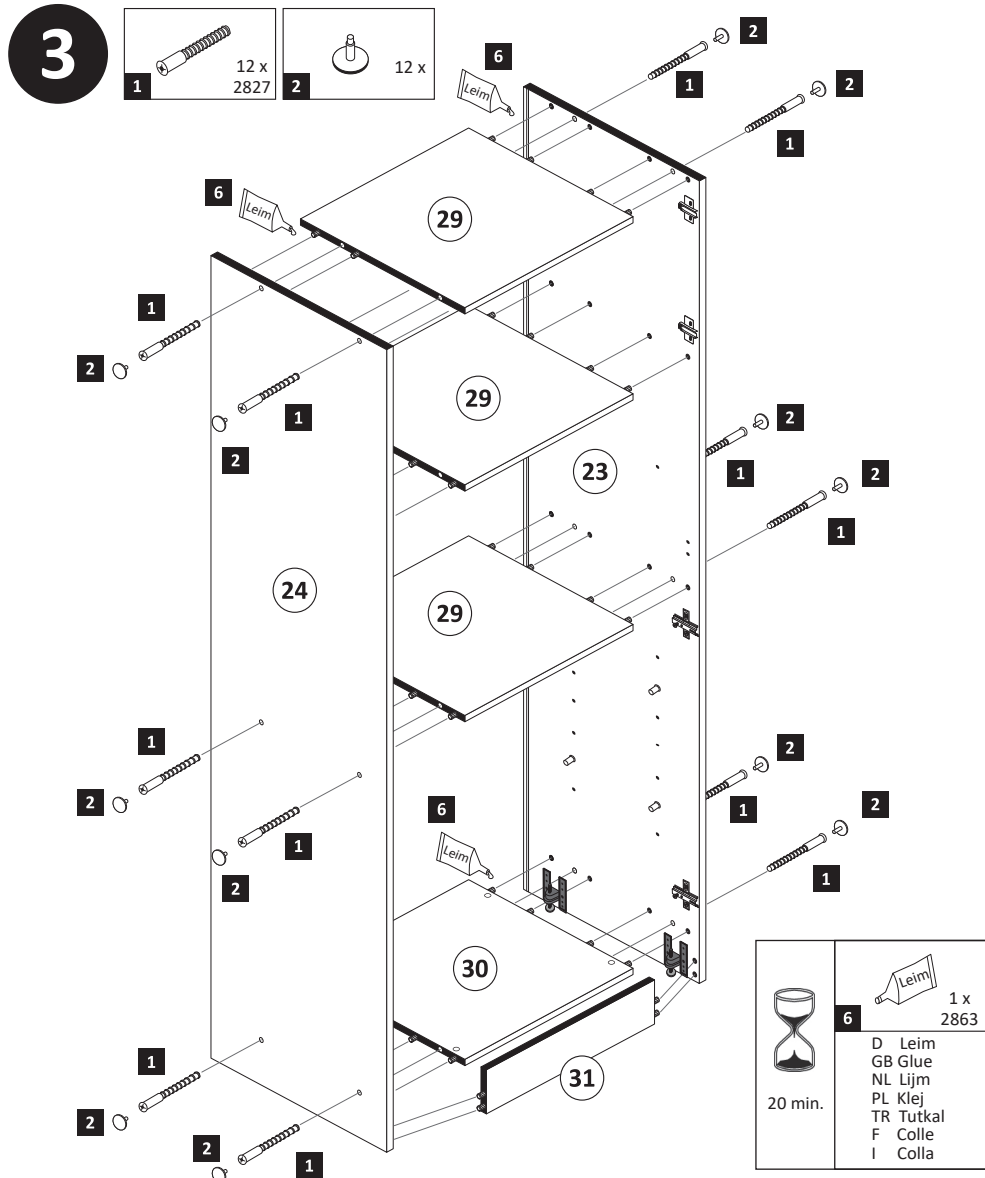
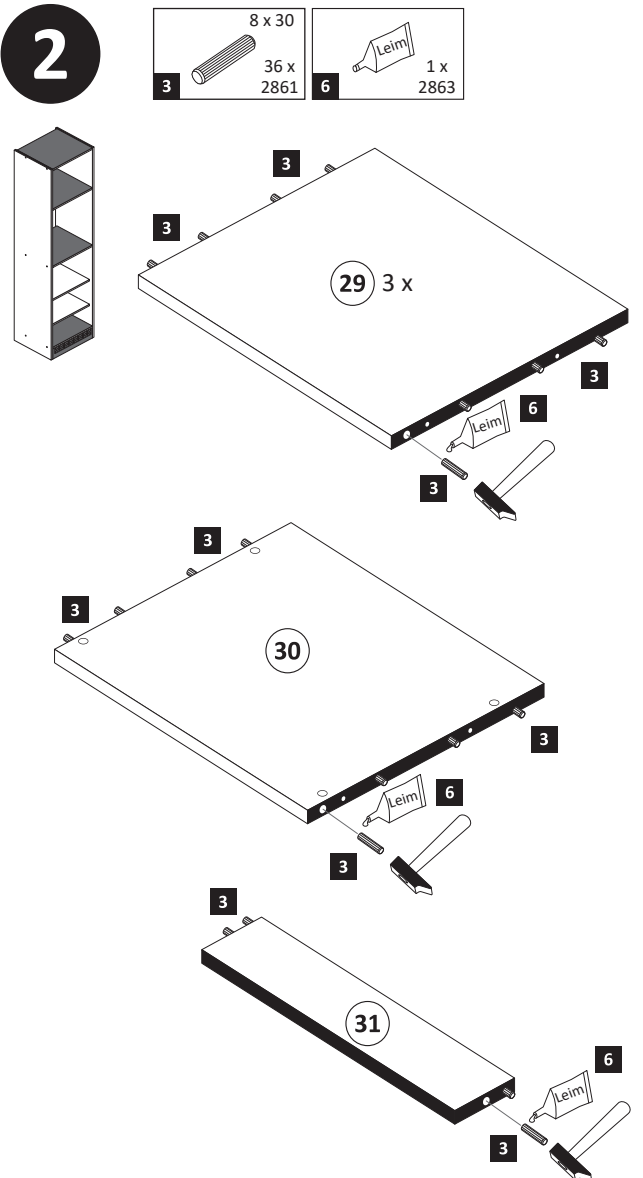
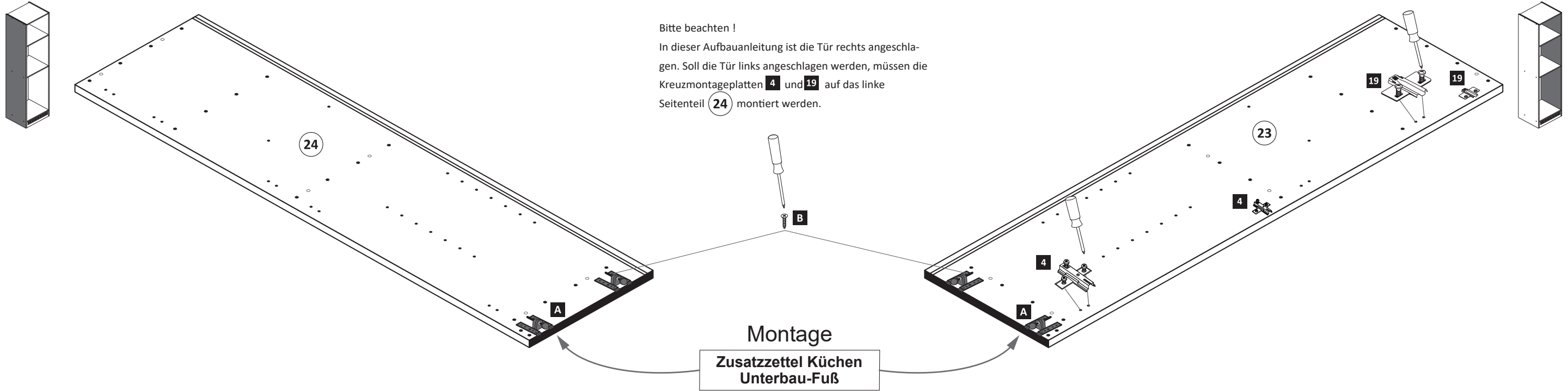

- 5**
- 7 3,5 x 15 8 x 2804
 - 11 gedämpft 4 x 2865
 - 20 gedämpft 4 x 1504

Variante A

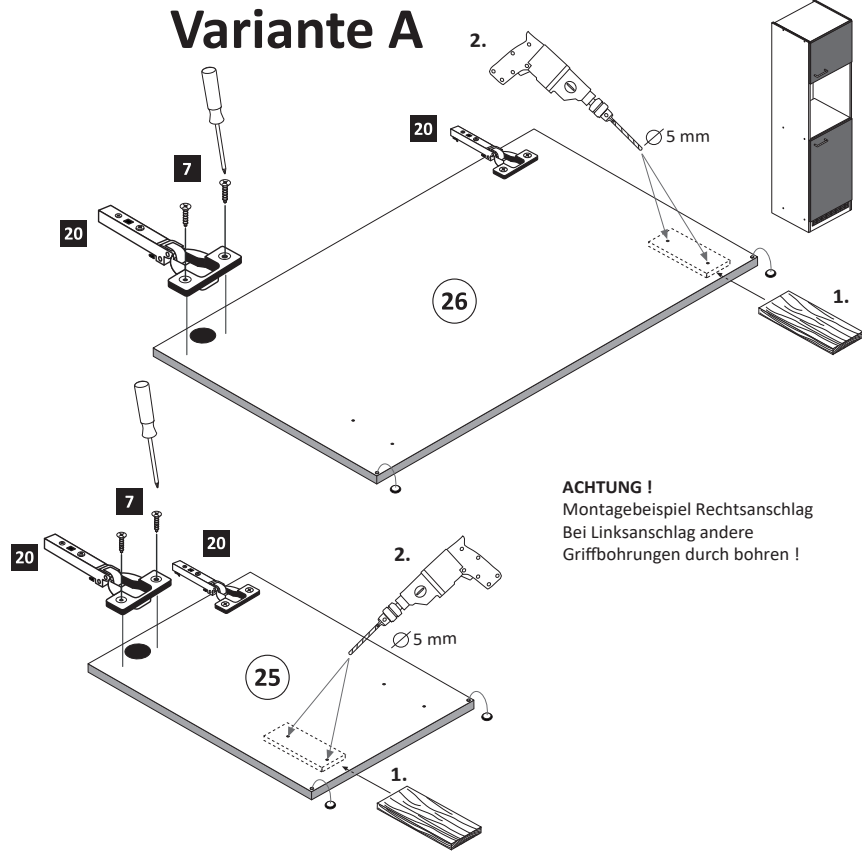

ACHTUNG!
Montagebeispiel Rechtsanschlag
Bei Linksanschlag andere
Griffbohrungen durch bohren!

- 5 2 x 1503
- 7 3,5 x 15 8 x 2804
- 11 gedämpft 4 x 2865
- 20 gedämpft 2 x 1504

Variante B

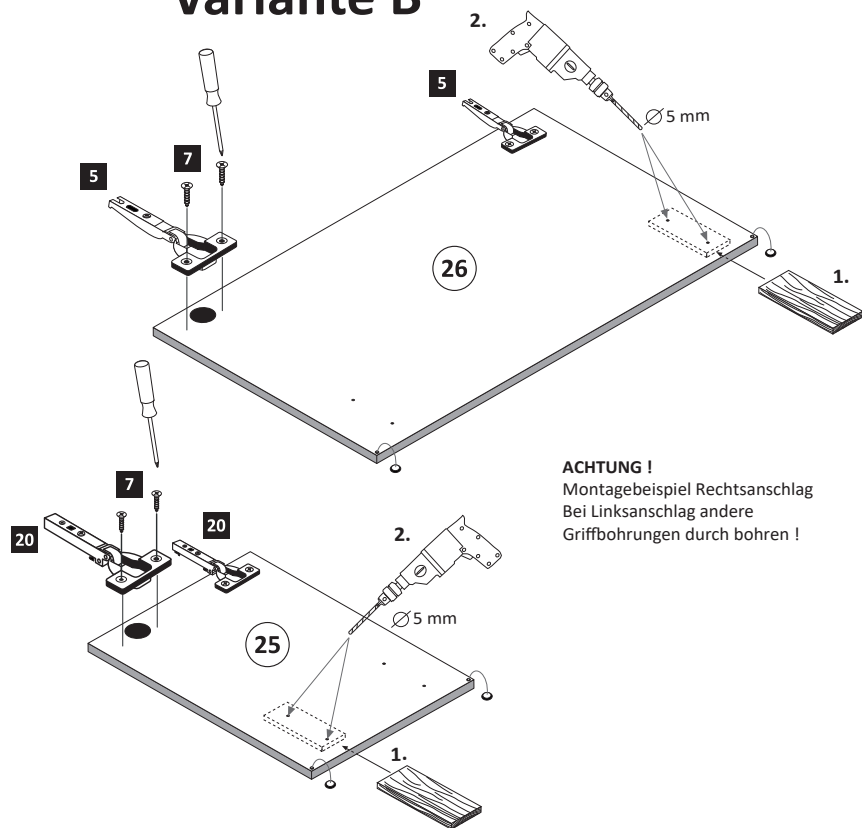

ACHTUNG!
Montagebeispiel Rechtsanschlag
Bei Linksanschlag andere
Griffbohrungen durch bohren!

6 Variante A

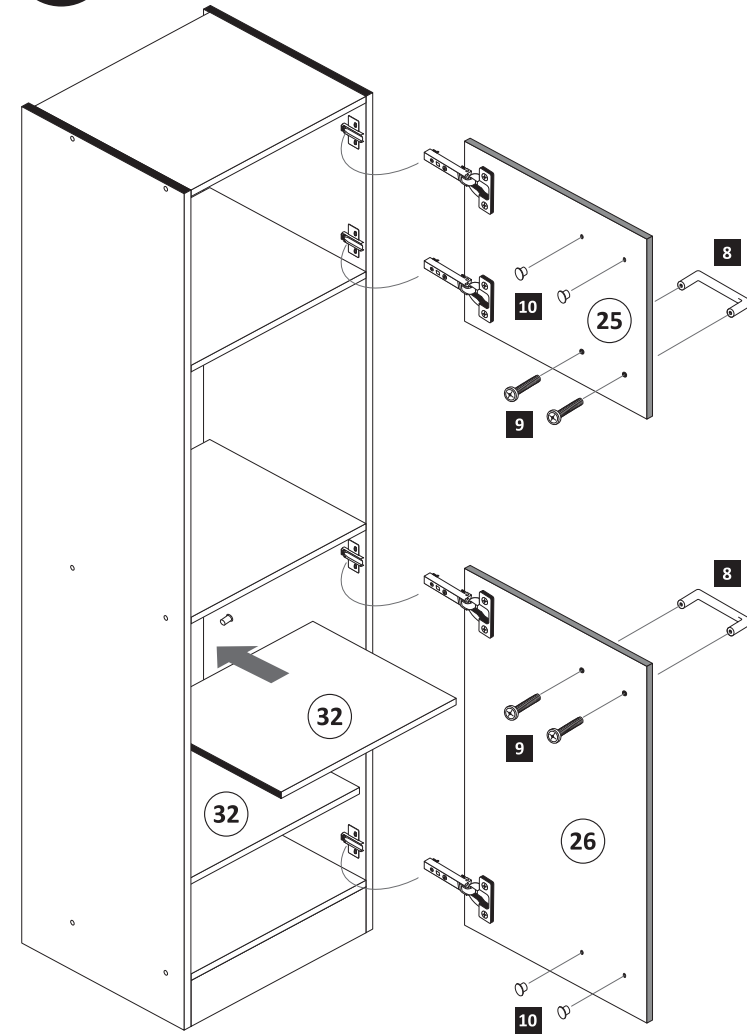

- 8 2 x
- 9 4 x
- 10 5mm 4 x 2855

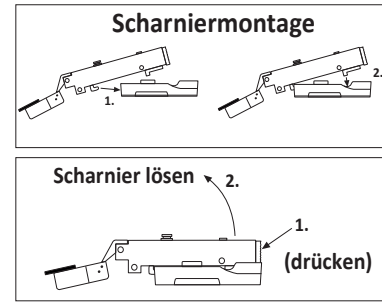

Variante B

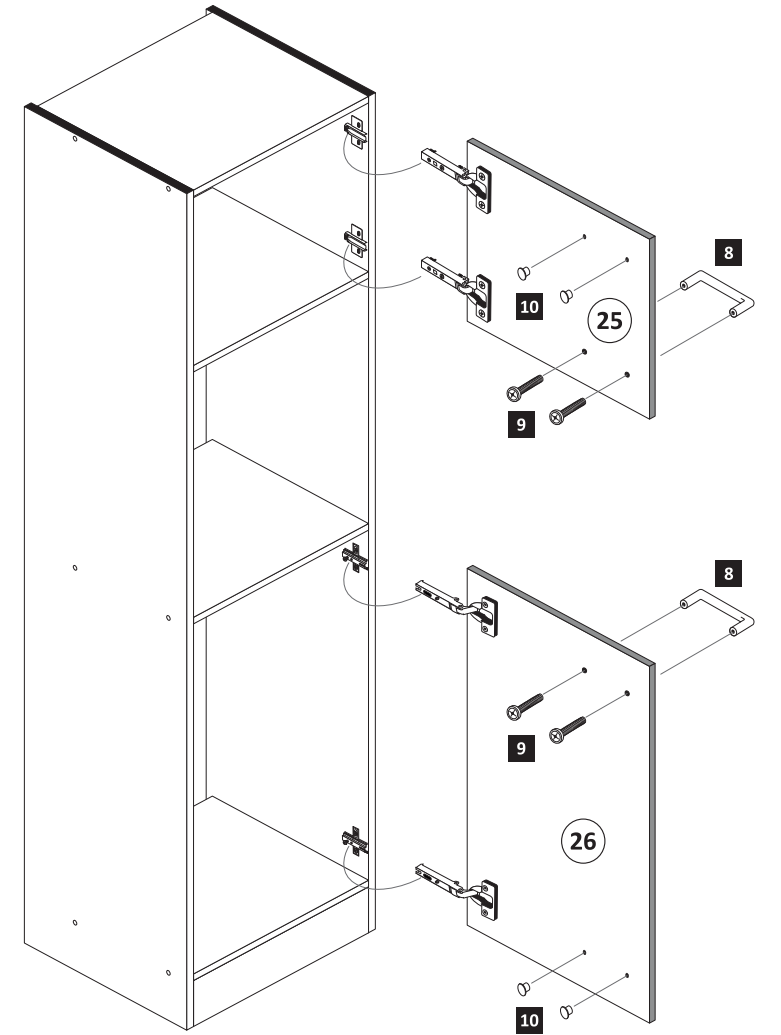

- 7**
- 13 1 x 2845
 - 14 6 x 34 1 x 2844
 - 15 4 x 45 1 x 2814
 - 16 3,5 x 15 1 x 2804
 - 17 4 x 15 1 x 2810

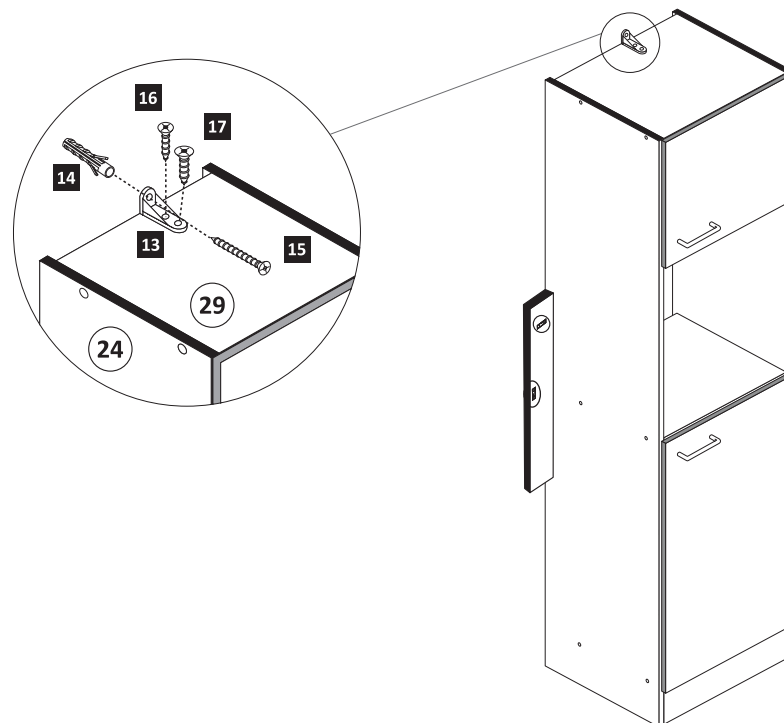

- 8**
- 18 4 x 9 2 x
 - 5 x 30 1 x

