

# -T120-1

Montageanweisung / Installation instructions / Instruction de montage / Istruzioni di montaggio  
montagehandleiding / Instrukcja montazu / Montaj talimatlar / Osszeszerelési útmutató / Nàvod k montázi /  
Nàvod na montaz / Instrucțiune de montaj / Инструкция по монтажу / Montaj talimatina / Monteringsanvisningar  
Upute za montažu / Instrucciones de Montaje / Navodila za montažo

# START

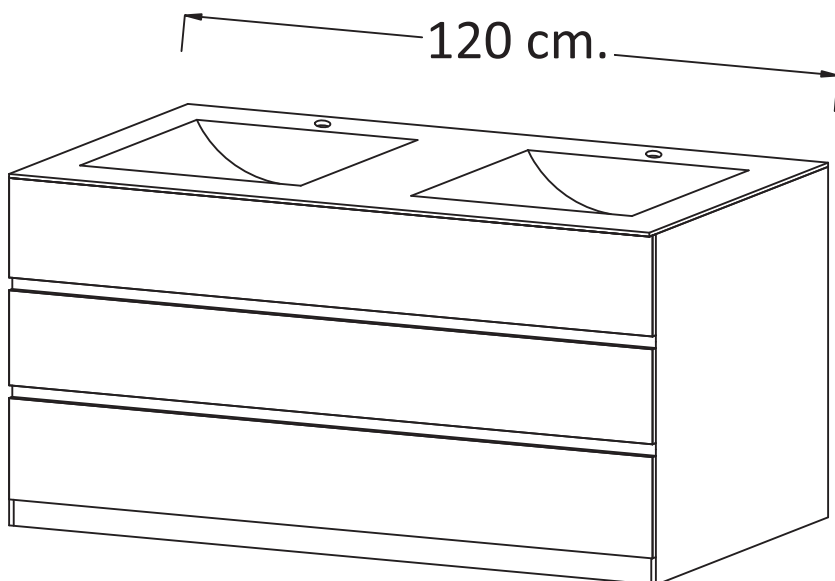
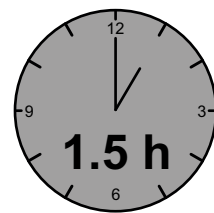
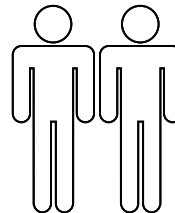
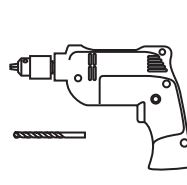
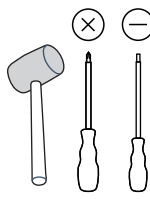
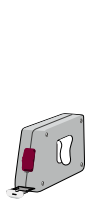

**D** – bitte lesen sie diese montageanleitung gut durch,  
Da wir für fehler, die durch falsche montage entstehen,  
Keine haftung übernehmen!

**Gb** – please read these installation instructions  
Through carefully as we cannot accept any liability  
For faults occurring as a result of incorrect installation!

**Cz** – přečtěte si prosím pozorně tento návod k montáži,  
Aby jste předešli chybám vzniklých špatnou montáží,  
Za které neručíme!

**F** – veuillez lire attentivement cette notice de montage,  
Car nous déclinons toute responsabilité en cas d'erreurs  
Découlant d'un montage erroné !

**I** – prego leggere attentamente le istruzioni per il montaggio,  
Poiché decliniamo qualsiasi responsabilità  
Per difetti derivanti da montaggio errato.

**S** - läs monteringsanvisningarna noggrant.  
Vi avsäger oss allt ansvar för defekter som  
Uppstår p.g.a. Felaktig montering.

**Hr** – pažljivo pročitajte upute za montažu,  
Jer otklanjamo svaku odgovornost za pogreške  
Nastale uslijed pogrešne montaže.

**Slo** – prosimo, da pozorno preberete navodila za montažo,  
Saj zavračamo vsakršno odgovornost za napake,  
Ki bi nastale zaradi napačne montaže.

**Nl** – leest u alstublieft deze montagehandleiding goed door,  
Voor fouten door verkeerde montage zijn wij niet verantwoordelijk.

**Pl** – prosze uwaznie zapoznac sie z instrukcja montazu,  
Poniewaz nie ponosimy odpowiedzialnosci za niewlasciwy montaz.

**HU** – Kérjük, olvassa el figyelmesen  
ezt az összeszerelési útmutatót,  
mert a helytelen összeszerelésből  
a dódó hibákért nem vállalunk felelősséget!

**SK** – Prosíme, dobre prečítajte si tento návod na montáž,  
pretože nepreberáme žiadne ručenie za chyby,  
ktoré vzniknú na základe chybnej montáže!

**RO** – Vă rugăm să cititi cu atenție aceste instrucțiuni  
de montaj deoarece nu preluăm garanția pentru defecte  
ce apar datorită unui montaj incorect!

**RUS** – Пожалуйста, внимательно ознакомьтесь ù  
с данной инструкцией по монтажу, поскольку мы не  
несем ответственности за ошибки, причиной которых  
является неправильный монтаж.

**TU** – İlkonce kullanma klavuzunu iyi okuyun,  
yalnis montaj yapasaniz bunun sorumlusu biz degiliz.

**ES** – Se ruega leer con atención las instrucciones  
de montaje debido a que declinamos cualquier  
responsabilidad  
por defectos derivados de un montaje erróneo.

LC120

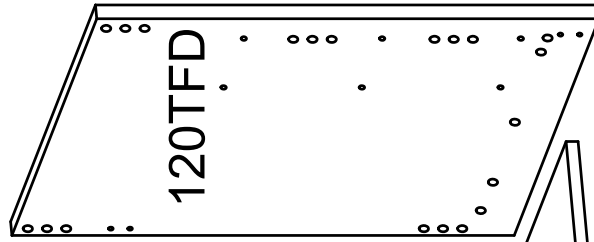

120TFD



120FAS

x5

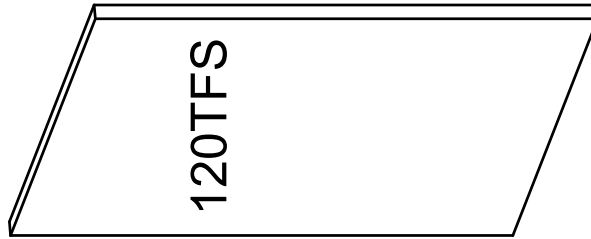

120TFS

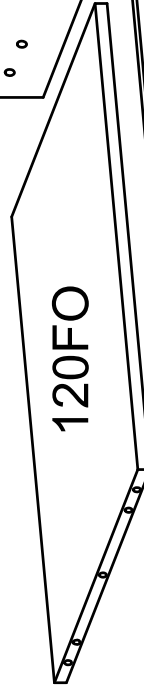

120FO



120TZOC



120SMS

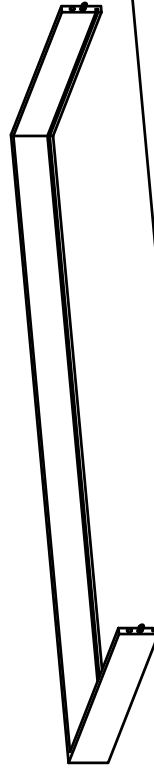

120SPO  
x2

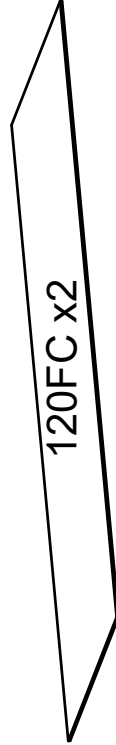

120FC x2

1200

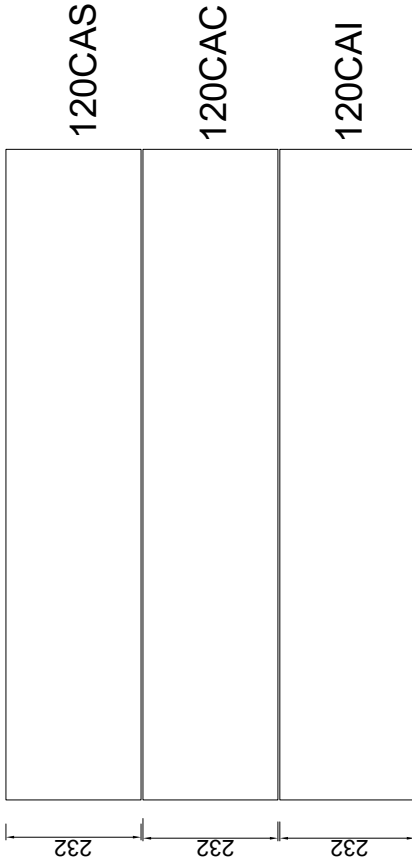

120CAS

120CAC

120CAI

232

232

232

120SMD



120SSIF



458 mm.



120SPC

120SPL x2







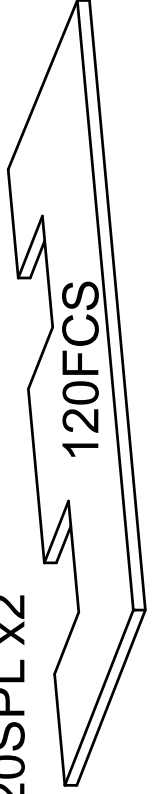

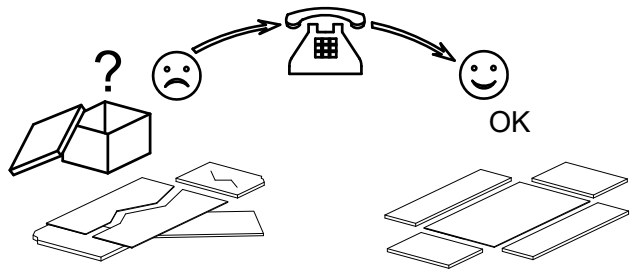
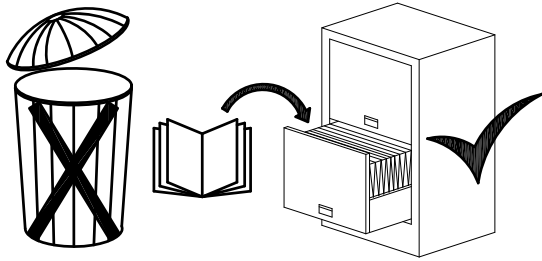

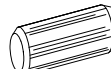
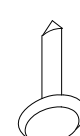
187 mm.

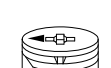

120FCS

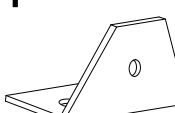
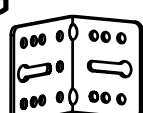



<p><b>B</b></p>  <p>8x30 mm. <b>x30</b></p>	<p><b>CH</b></p>  <p><b>x6</b></p>	<p><b>E11</b></p>  <p>6x11 mm. <b>x16</b></p>
<p><b>C</b></p>  <p>∅15 x 12 mm <b>x14</b></p>	<p><b>P</b></p>  <p><b>x6</b></p>	<p><b>TC</b></p>  <p>4x16 mm. <b>x8</b></p>
<p><b>D</b></p>  <p><b>x14</b></p>	<p><b>L3516</b></p>  <p>3.5x16 mm. <b>x38</b></p>	<p><b>PST</b></p>  <p><b>x4</b></p>
<p><b>ANG</b></p>  <p><b>x2</b></p>	<p><b>L312</b></p>  <p>3x12 mm. <b>x4</b></p>	<p><b>C1</b></p> <p>531010-01SCFS</p>  <p>∅12 mm. <b>x4</b></p>
<p><b>L430</b></p>  <p>4x30 mm. <b>x14</b></p>	<p><b>D1</b></p>  <p><b>x4</b></p>	

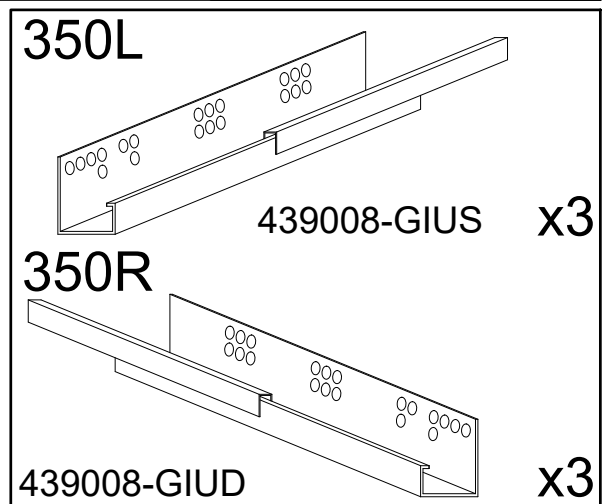
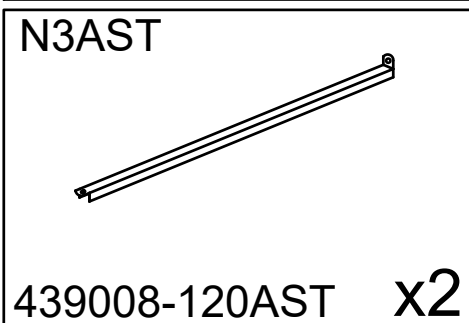

1

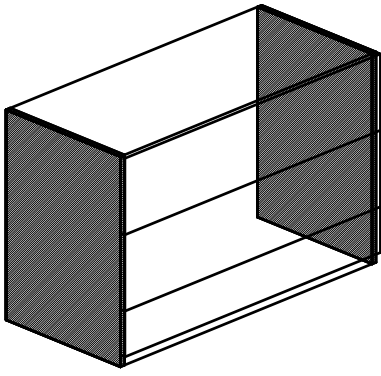

TC



4x16 mm.

x8

PST

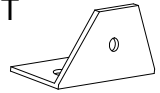

x2

ANG

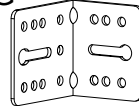

x2

L3516



3.5x16 mm.

x4

CH



x6

E11



6x11 mm.

x12

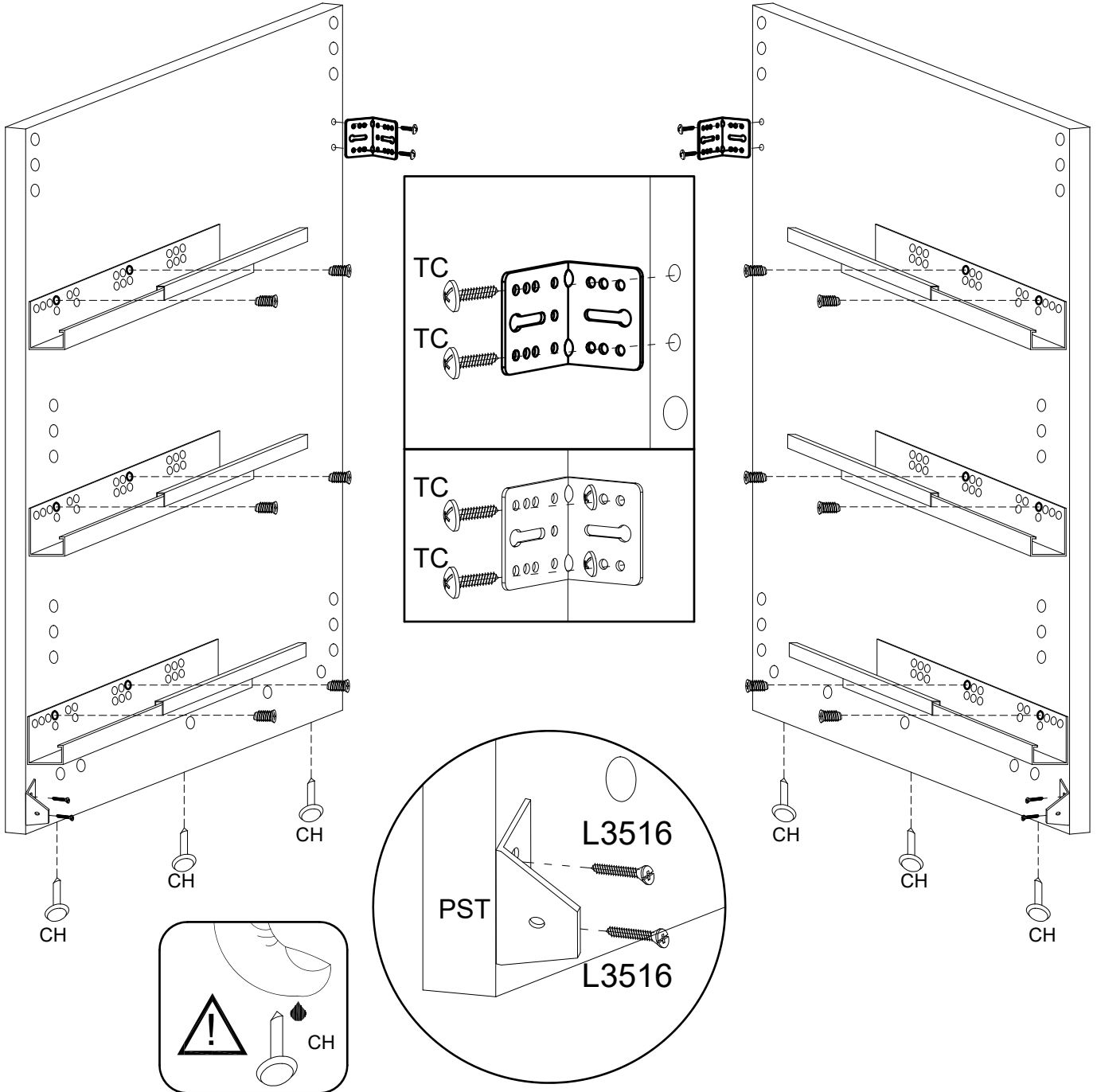

350L

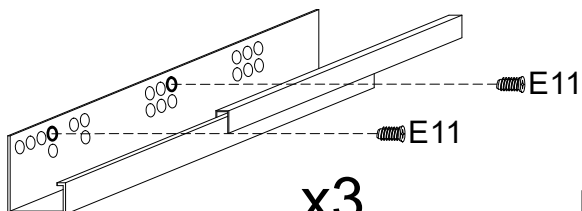

x3

L

350R

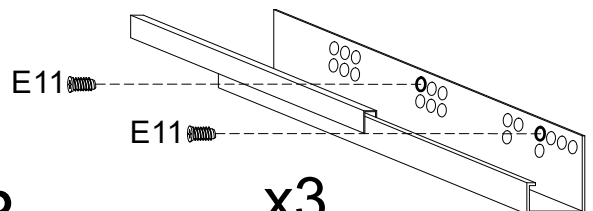

x3

R

# 2

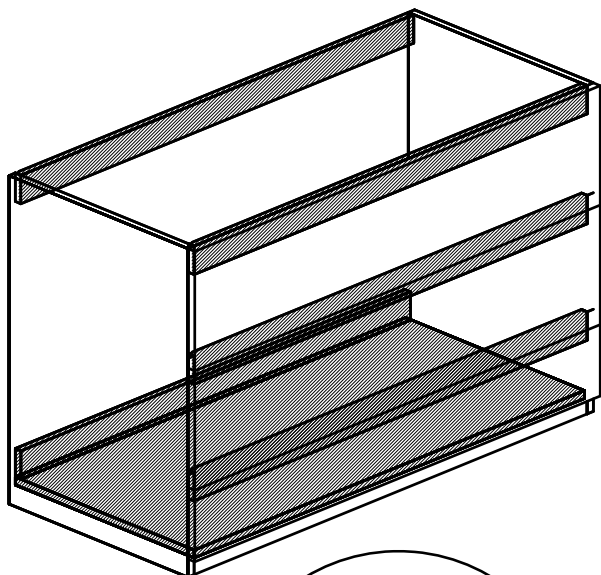
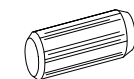
**B**

8x30 mm.

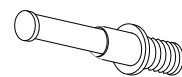
**x26****D****x14****L3516**

3.5x16 mm.

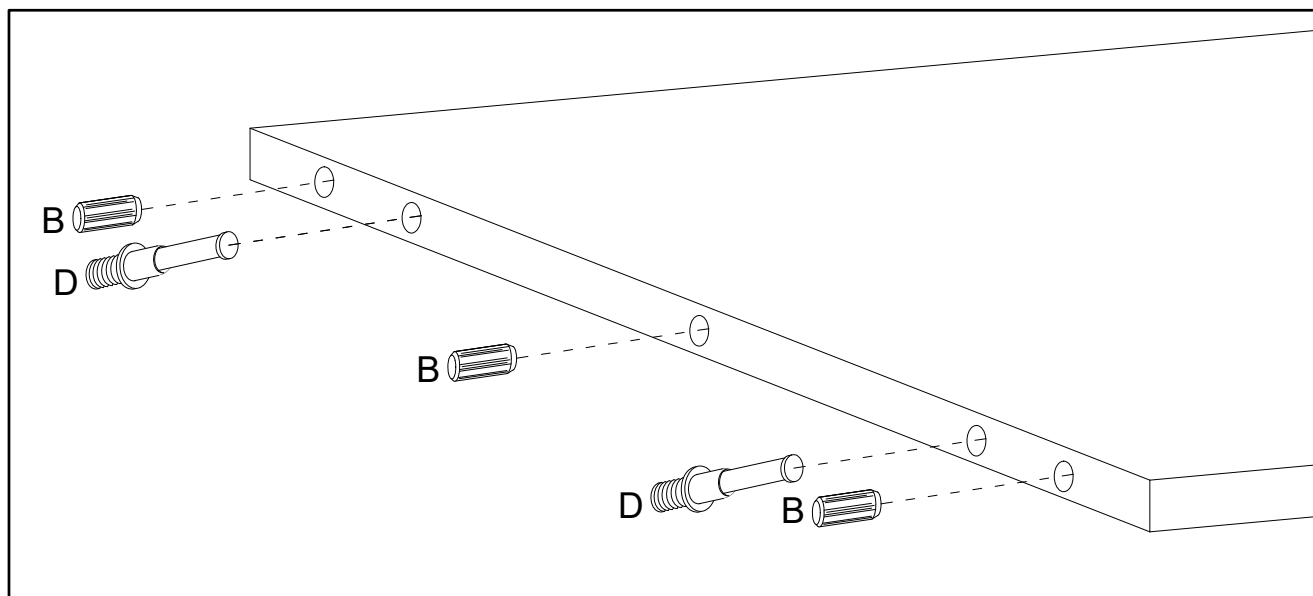
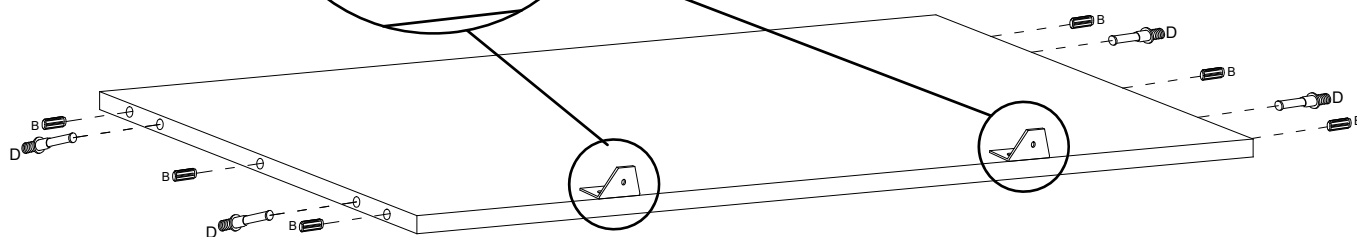
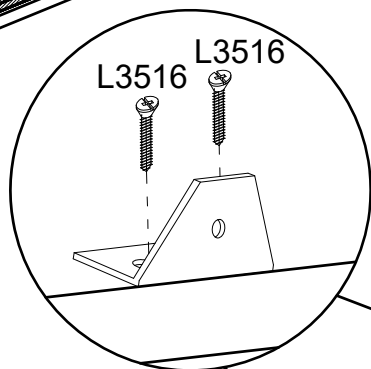
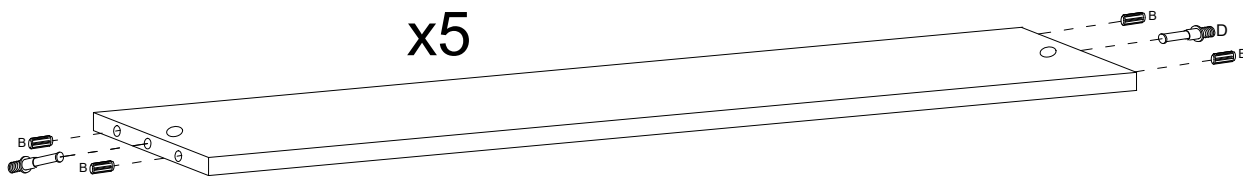
**x4****PST****x2****x5**

C x7  
ø15 x 12 mm

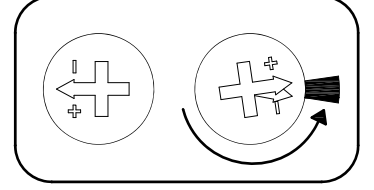
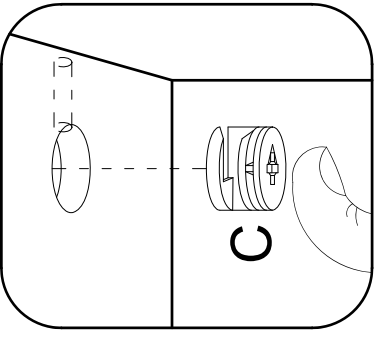
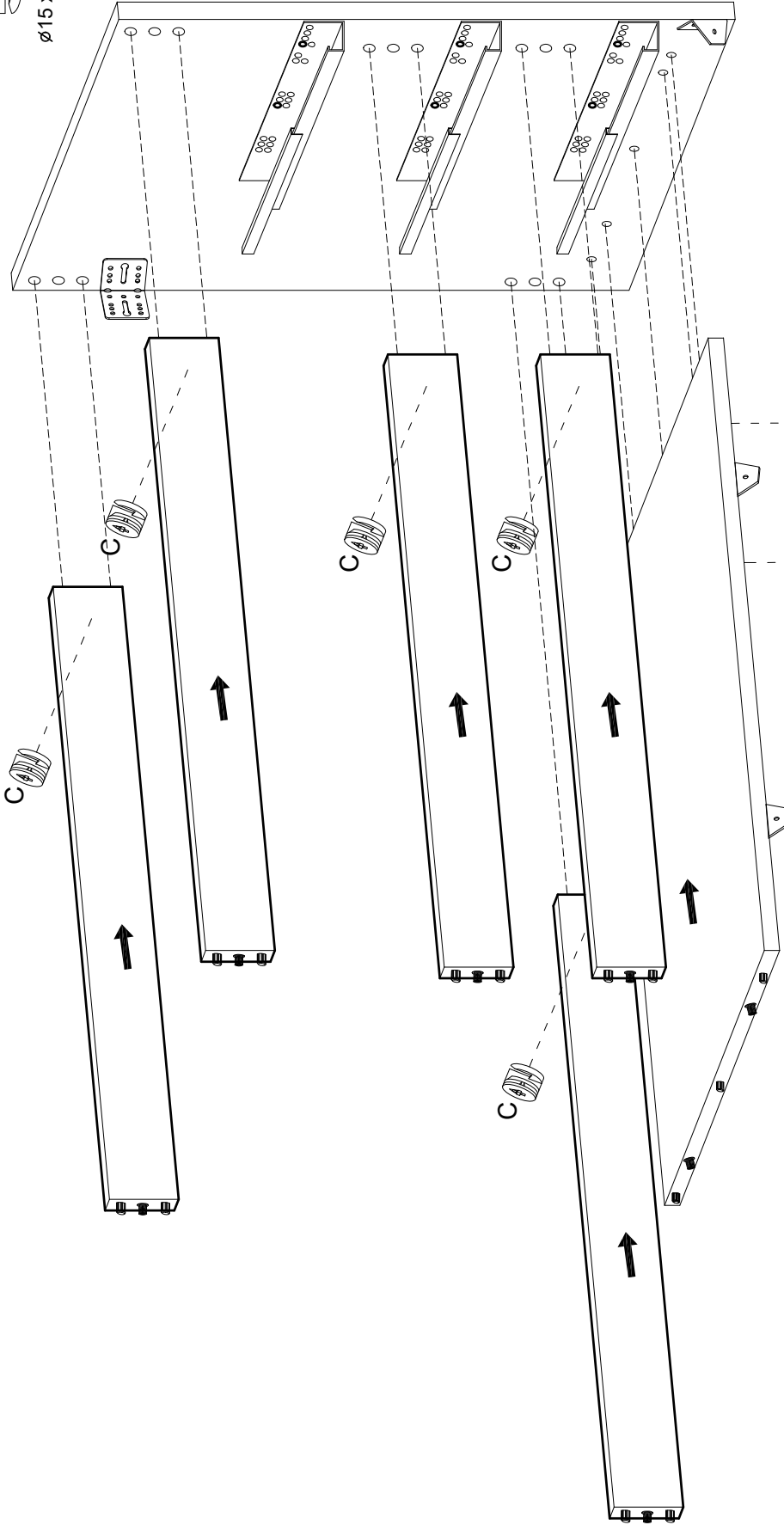

4

C



ø15 x 12 mm

x7

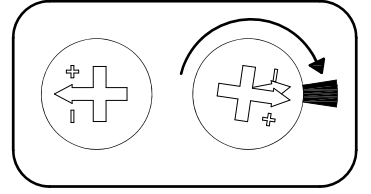
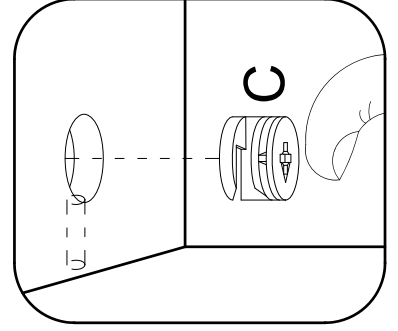
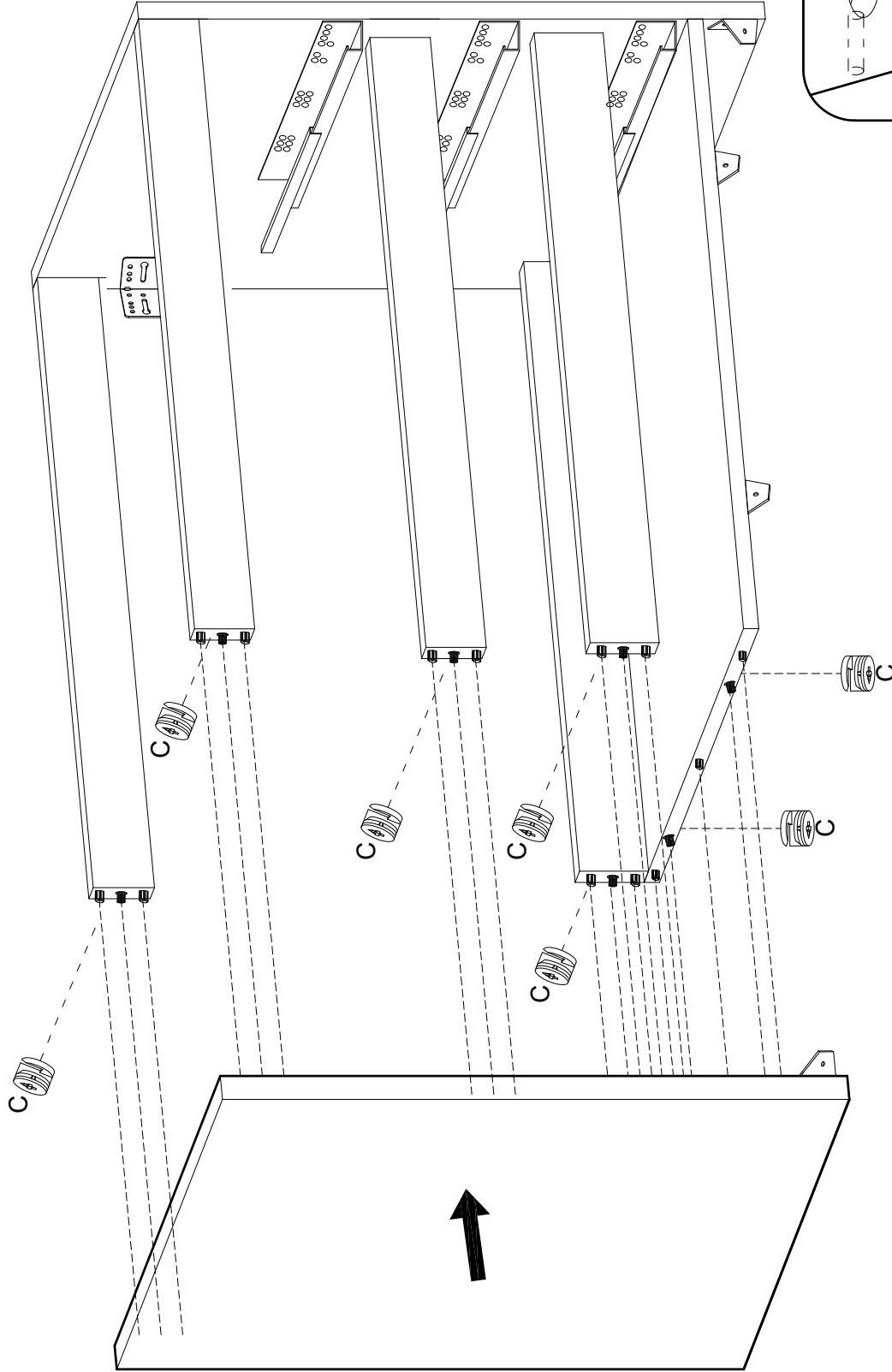

5

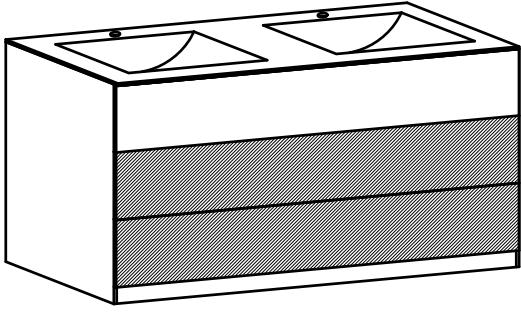

P



C1



ø12 mm.

x4

x4

L312

D1



x4

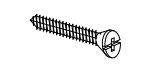

3x12 mm. x4

N3AST

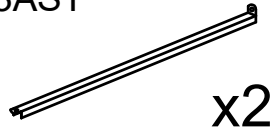

x2

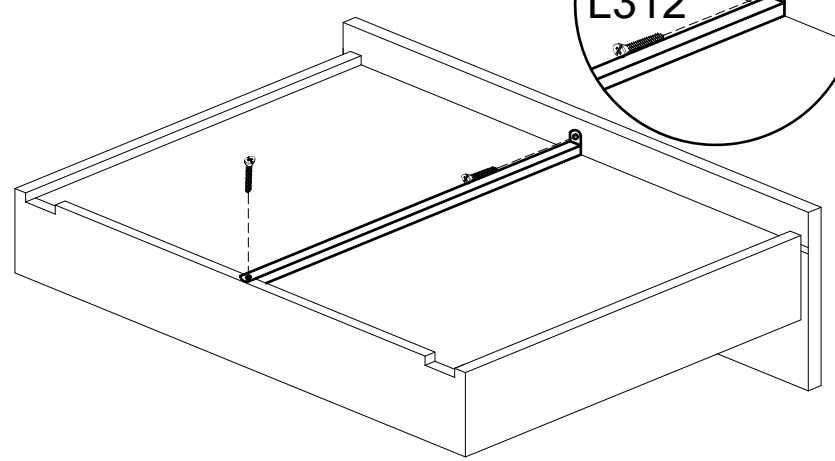
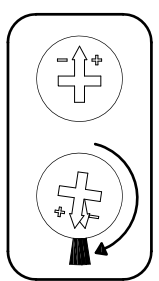
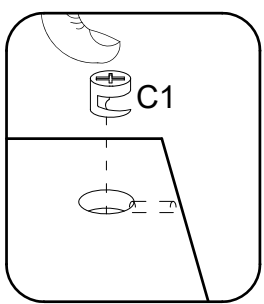
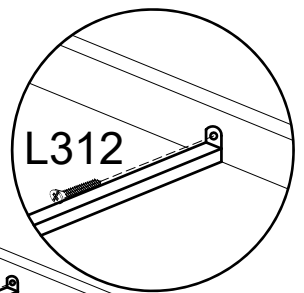
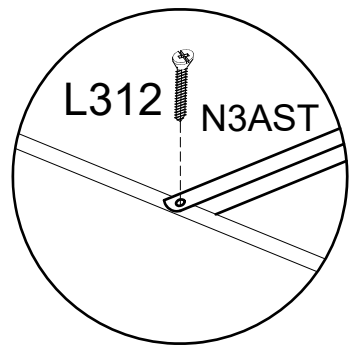
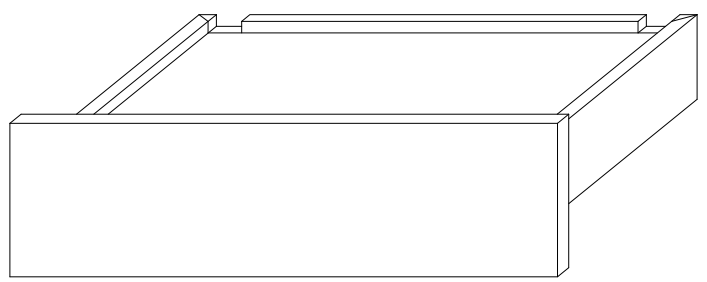
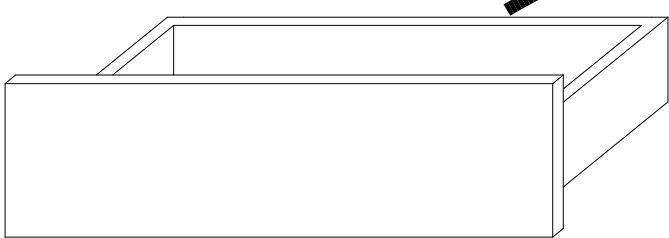
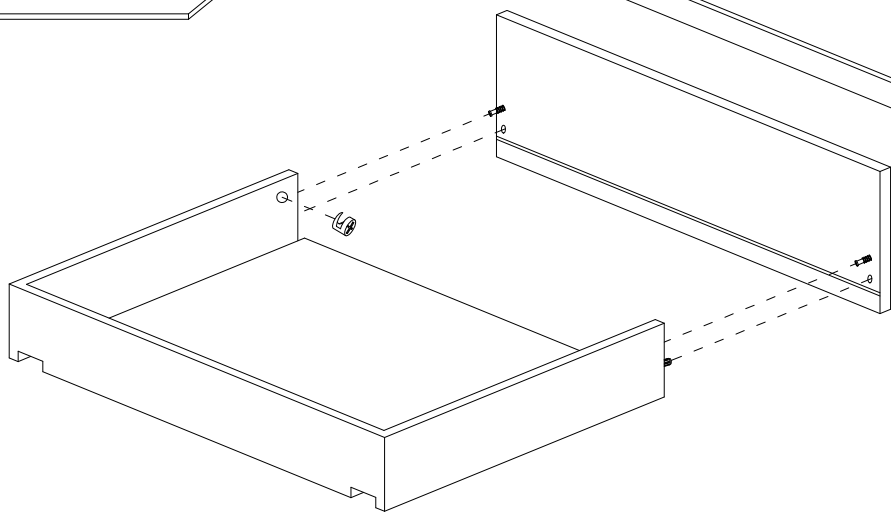
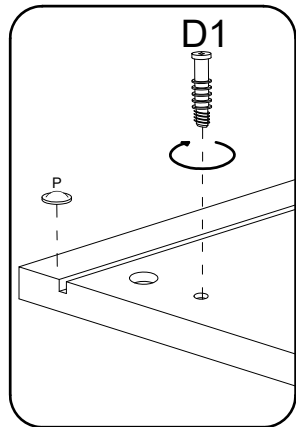
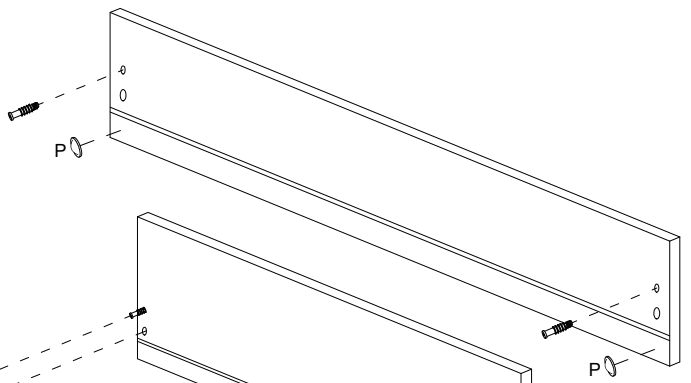
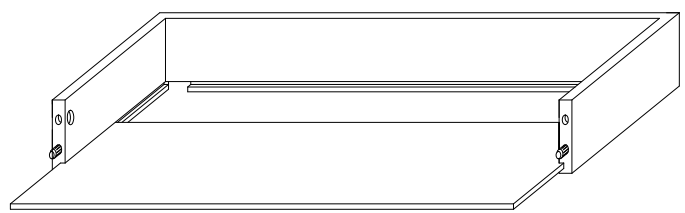



# 6

E11

L3516

6x11 mm. x4

3.5x16 mm. x10

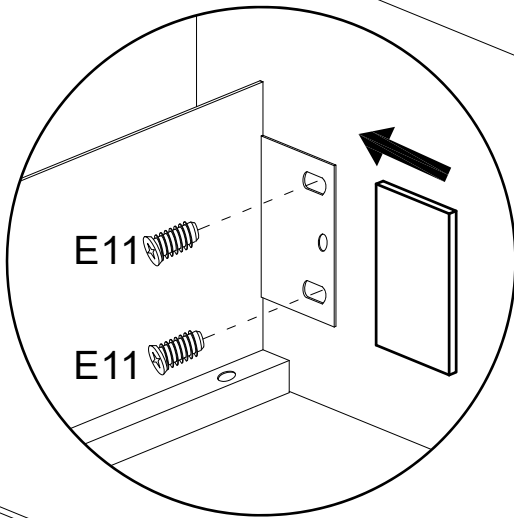
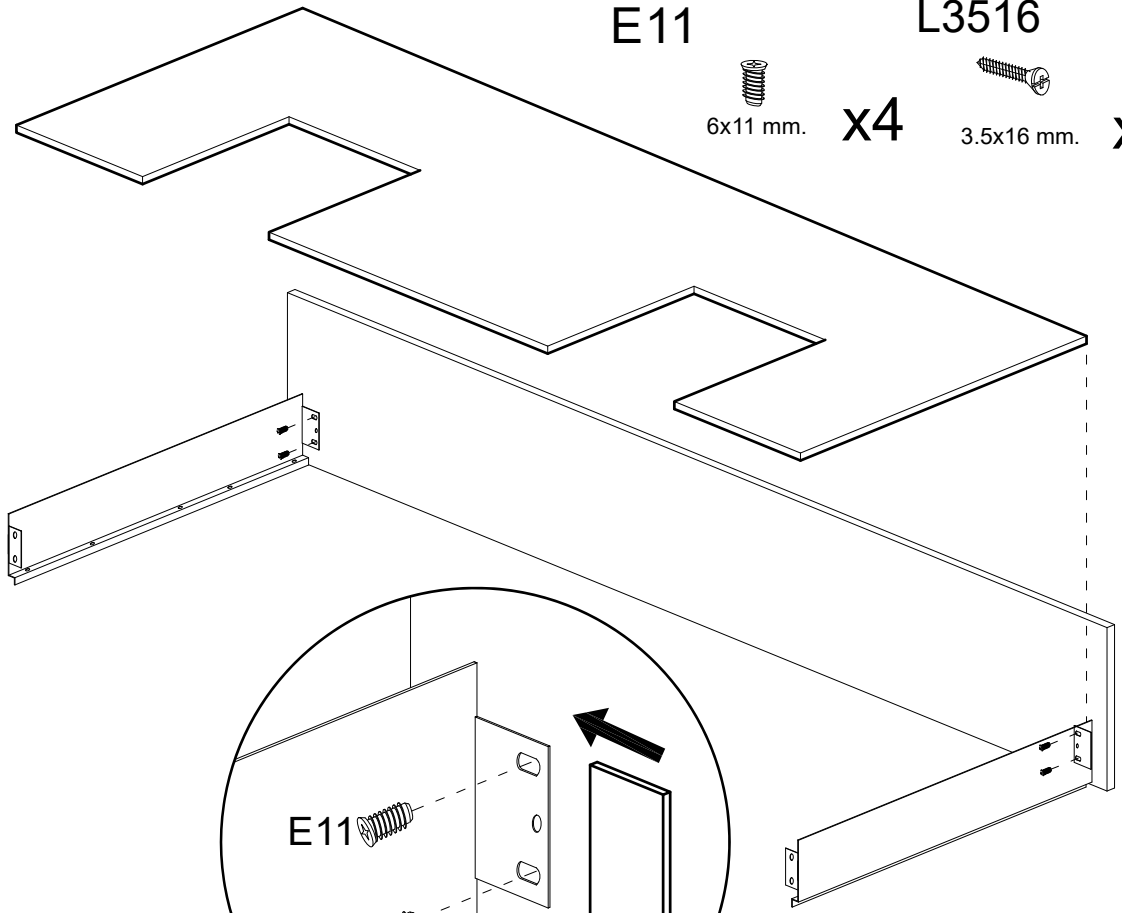

P



x2

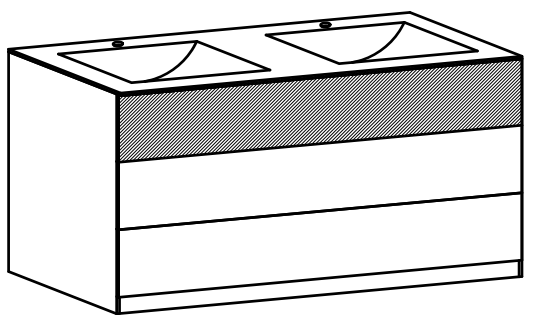
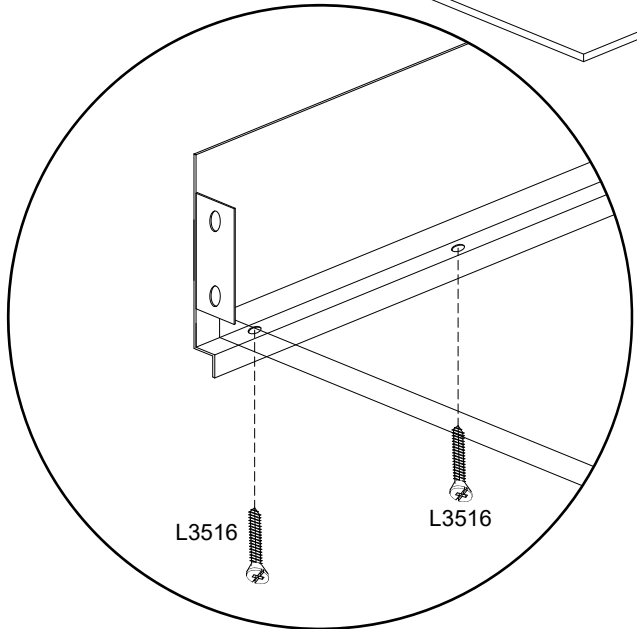
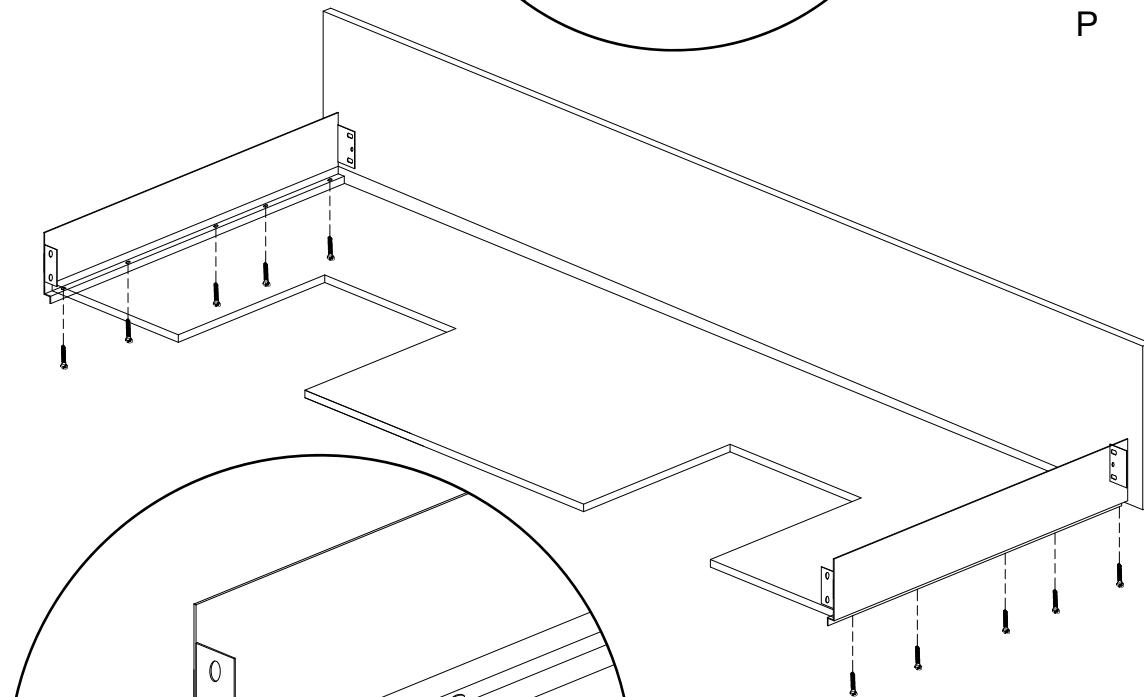

7

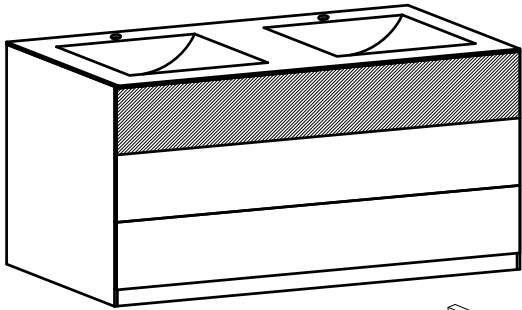

L3516

L430



3.5x16 mm.

x15



4x30 mm.

x4

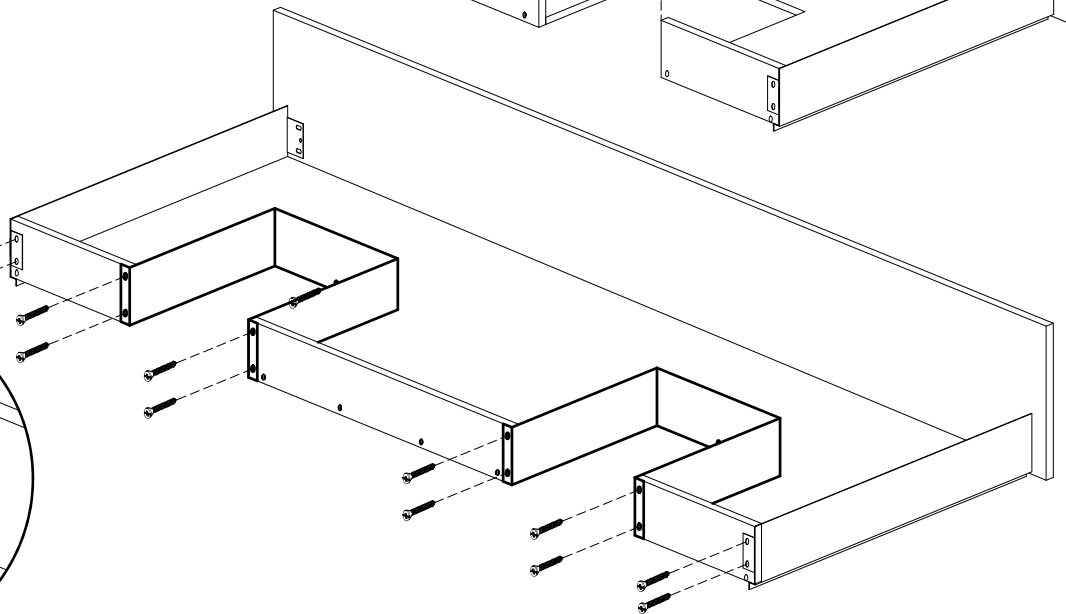
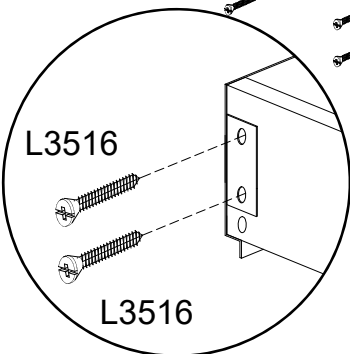
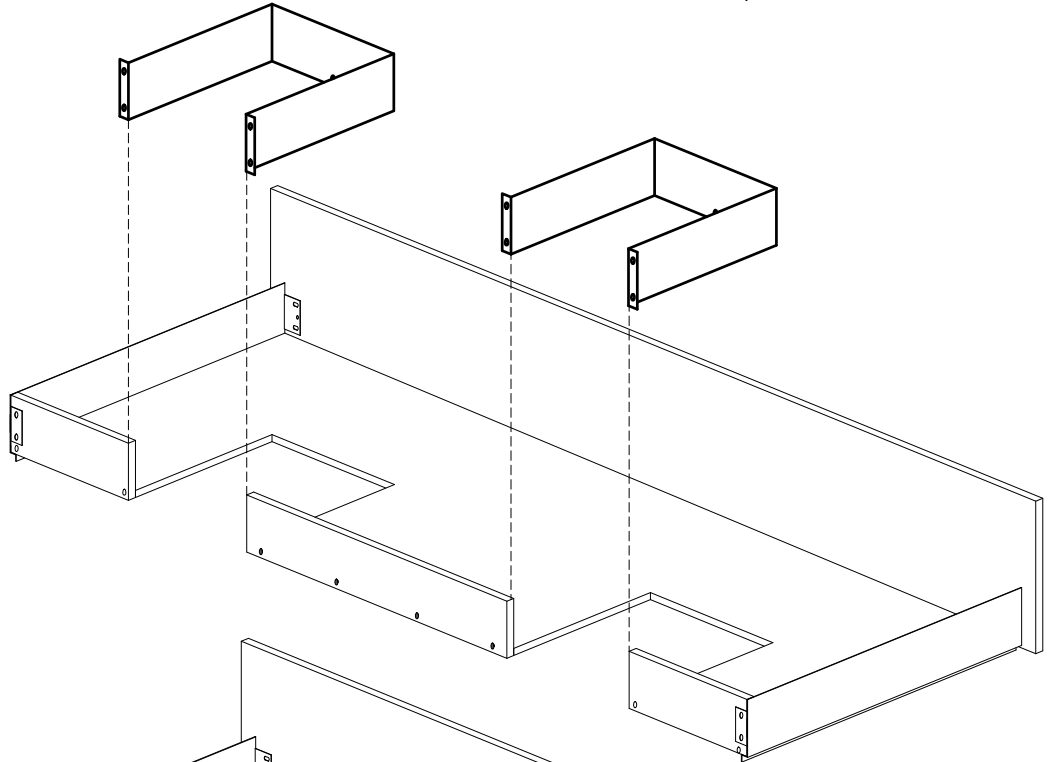
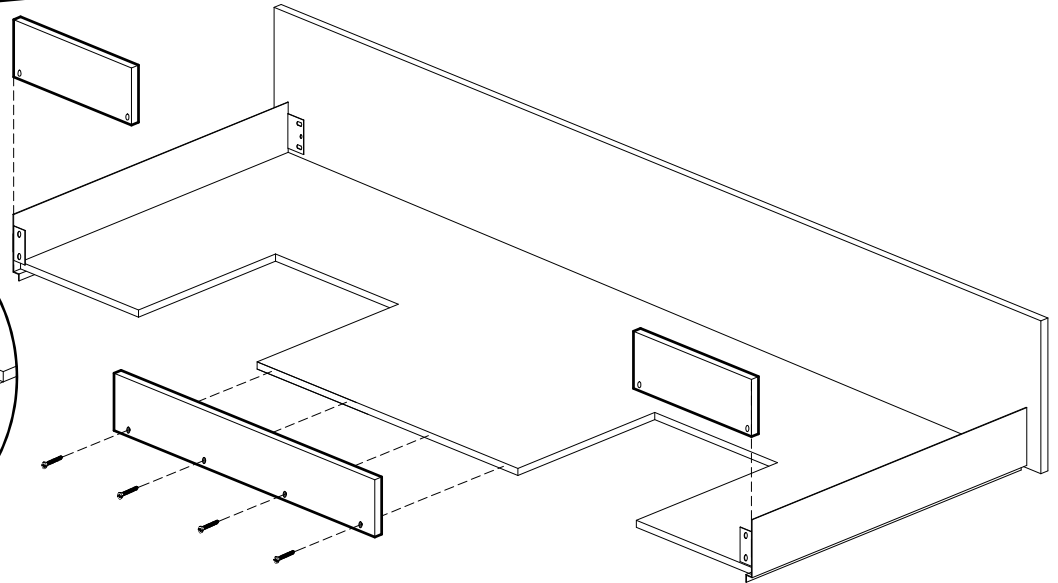
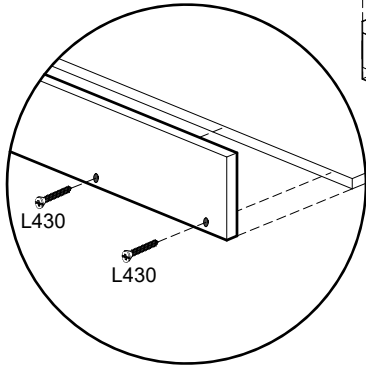

# 8

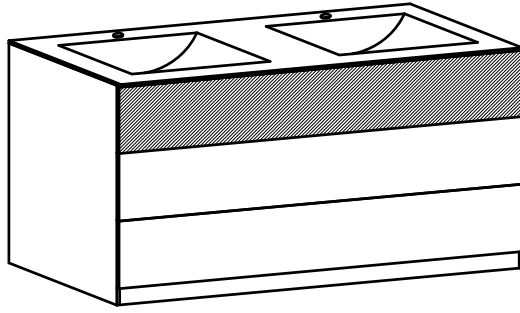

PST

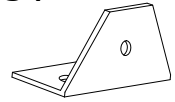

x1

L3516



3.5x16 mm.

x3

L430



4x30 mm.

x4

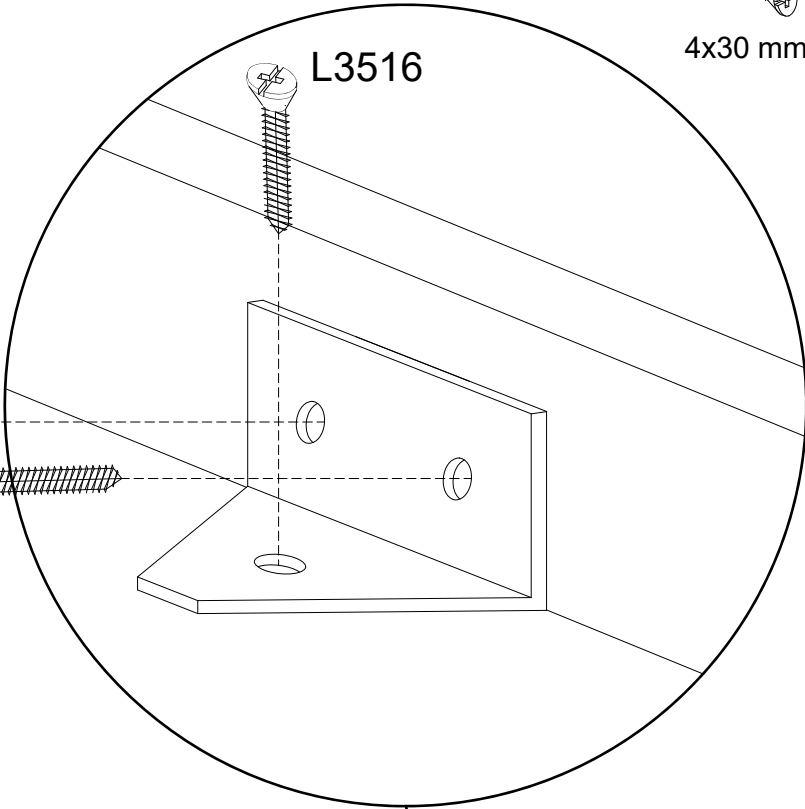

L3516

L3516

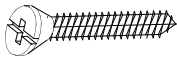

L3516

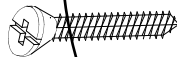

L430

L430

L430

L430

# L430

9

L3516



X3

3.5x16 mm.

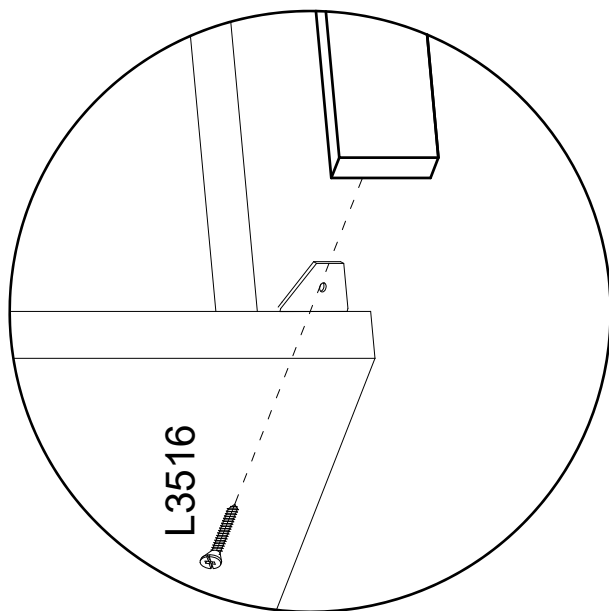
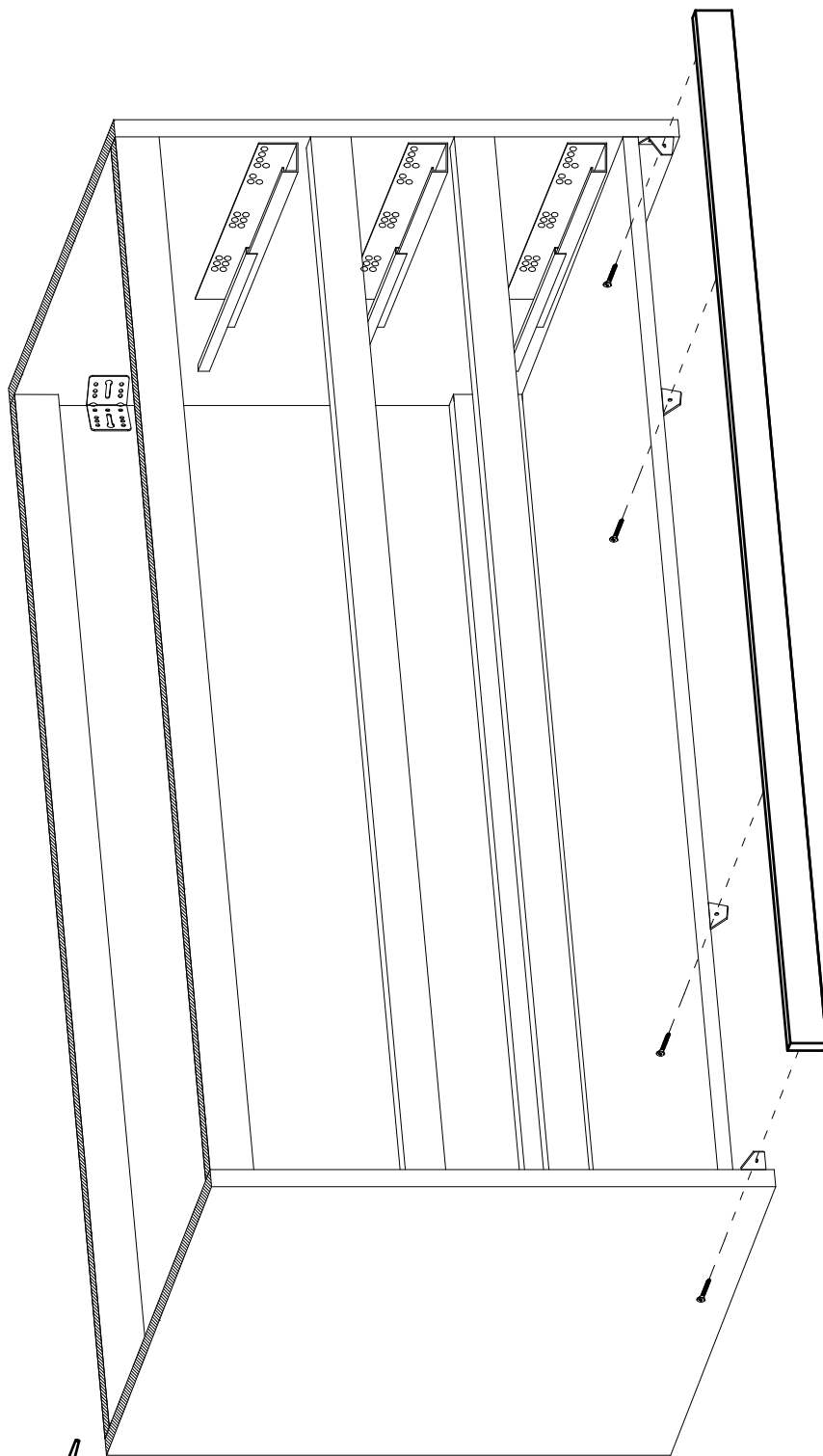
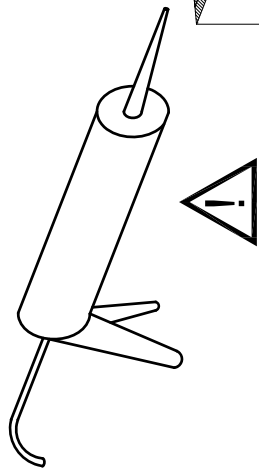
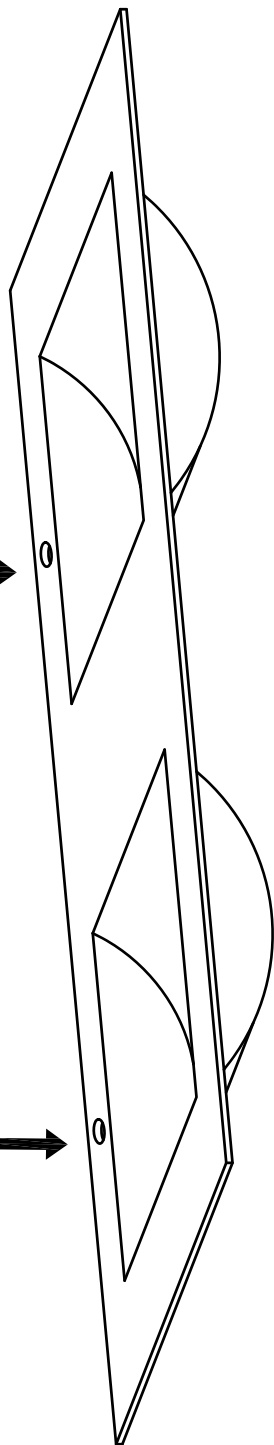

# 10

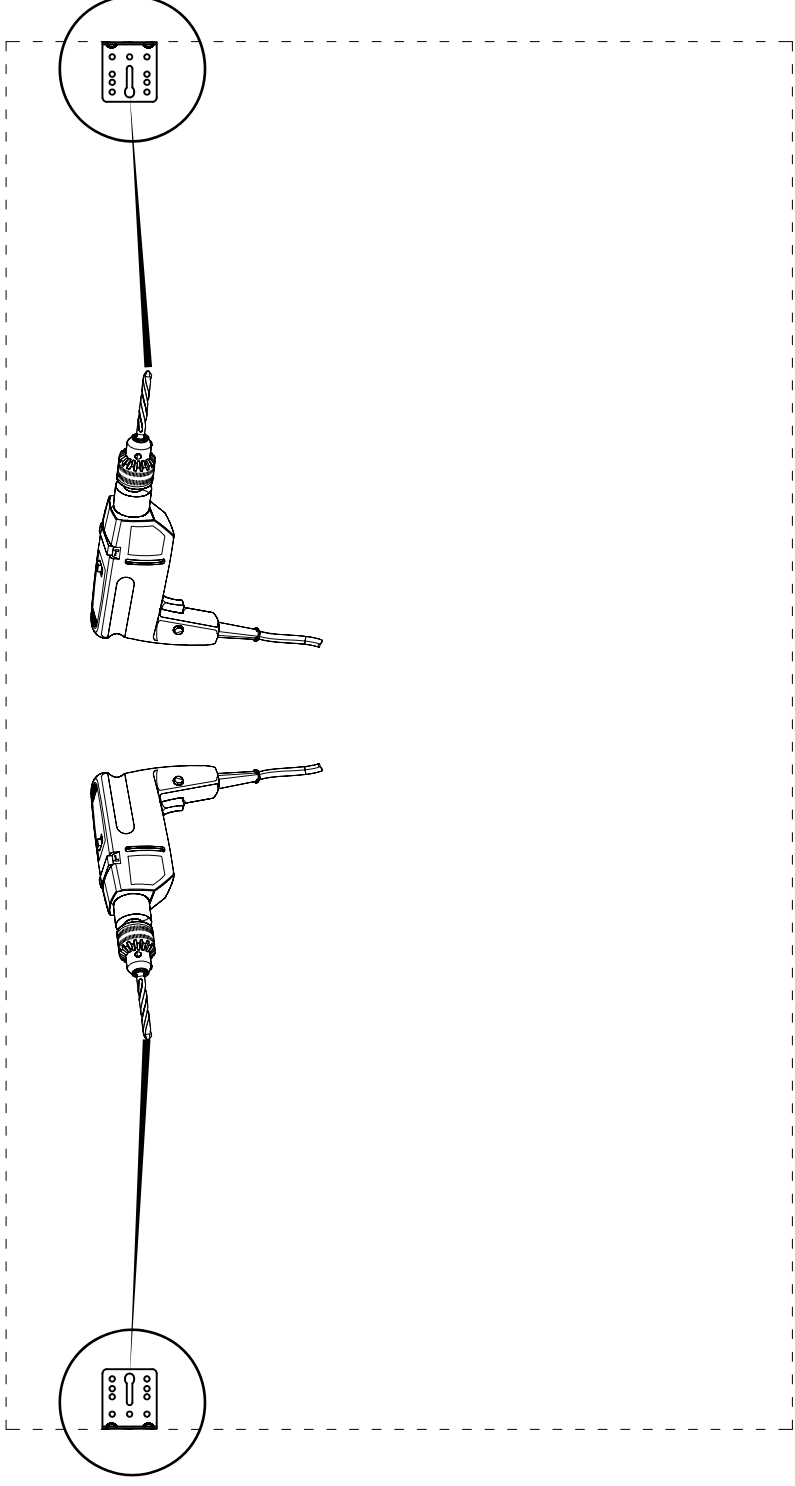

Sehr geehrter Kunde, die Montage der Haengeelemente muss von Fachpersonal ausgefuehrt werden! Bitte verwenden Sie eigene, der Beschaffenheit der Wand entsprechende Duebel. Zu Ihrer eigenen Sicherheit legen wir dem Beschlagbeutel keine Fischerd uebel bei.

Gentile Cliente

Il montaggio dei pensili deve essere effettuato da personale competente. I tasselli di fissaggio non sono compresi nella ferramenta. Scegliere il tipo di tassello per il fissaggio più adatto alla tipologia di muro. Assicurarsi l'idoneità della parete per un sostegno sicuro del pensile.

Cher client,

l'installation des meubles suspendus doit être effectuée par un personnel compétent. Les fishers ne sont pas inclus dans la quincaillerie. Choisir les types des fishers pour le fixation apte au mur. S'assurer de l'adéquation du mur pour support sûr du meuble

Dear Customer

The assembling of the hanging elements must be done by a competent staff. The fishers are not included in the hardware package. Choose the fisher more suitable to the type of the wall. Ensure the suitability of the wall for a secure support of the hanging element.



FR

ELEMENTS D'EMBALLAGE  
PACKAGING ITEMS

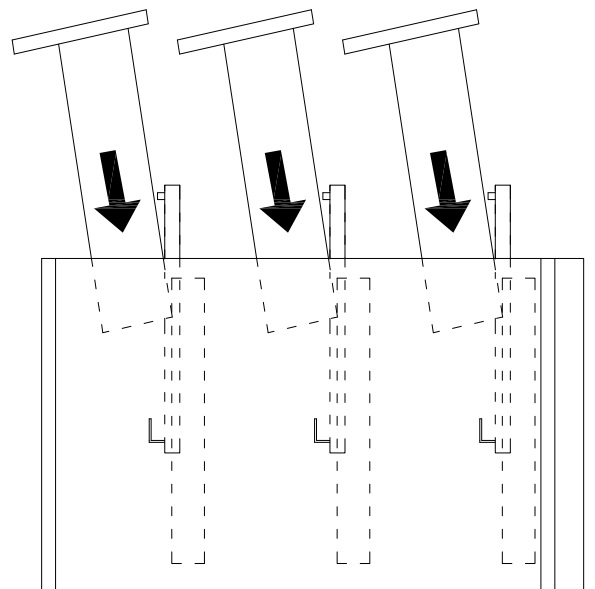
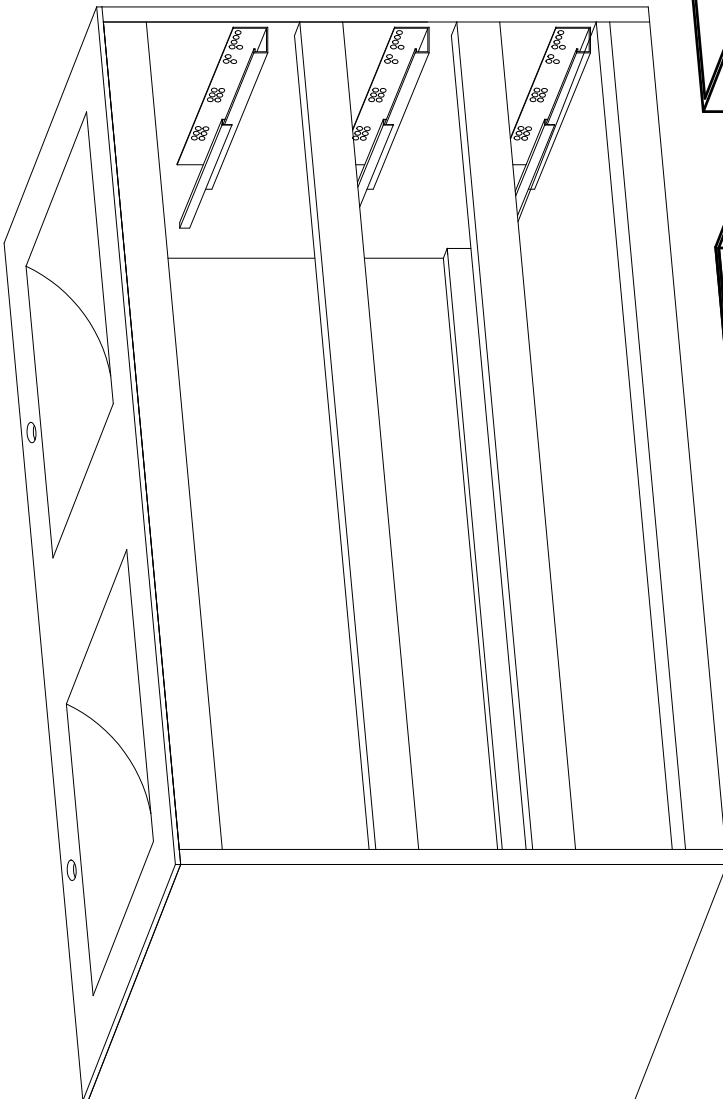

11