

Installationsanleitung Installation Instruction Instructions d'installation

N623P225502 / N623P225503 (140x200)
N623P225500 / N623P225501 (160x200)

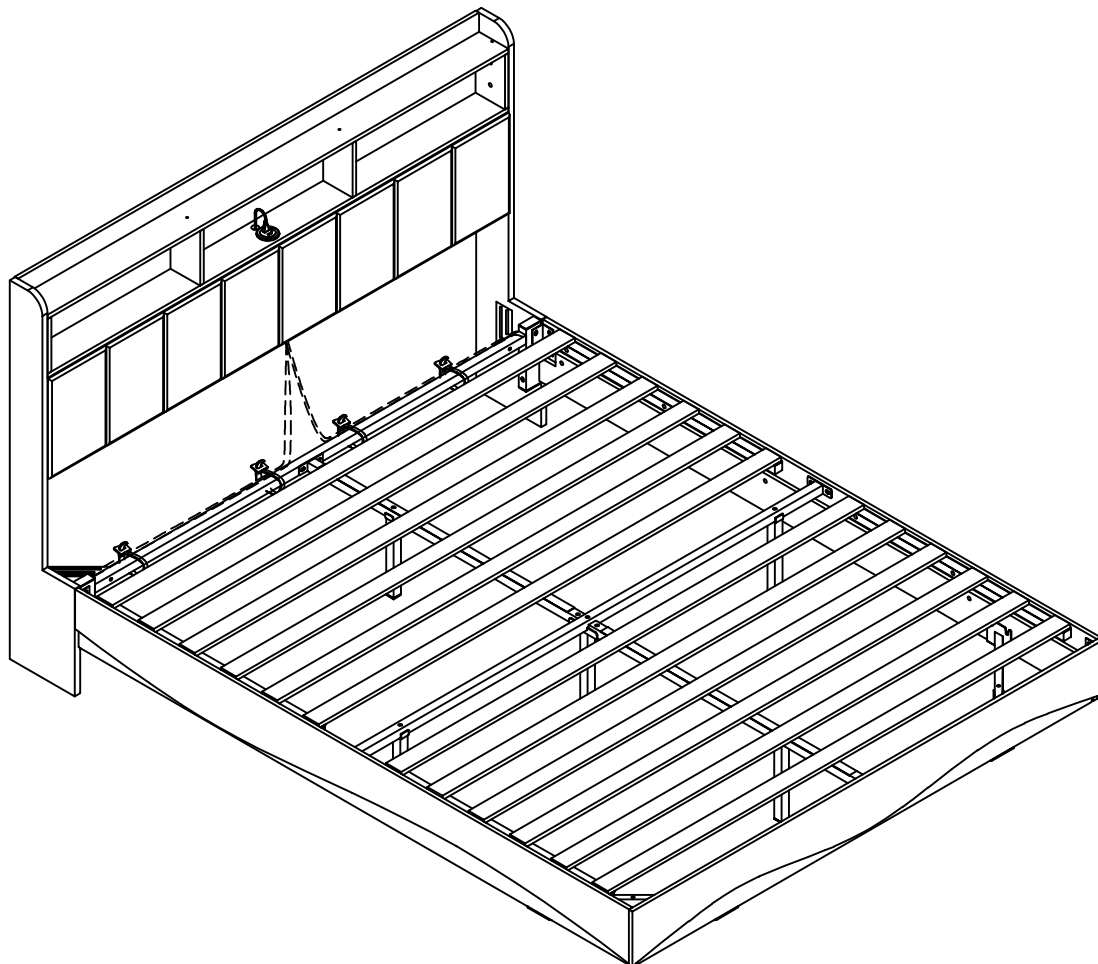

DE: Unser Produkt wird Ihnen in 2 packages geliefert. Die Lieferzeiten dieser 2-Pakete können abweichen, bitte haben Sie Geduld und danken Sie für Ihr Verständnis

UK: Our product will be delivered to you in 2 packages. The delivery times of these 2 packages may differ, please be patient and thank you for your understanding

FR: Nos produits vous seront livrés en paquets de 2. Le délai de livraison peut être différent pour les deux colis, veuillez patienter, merci de votre compréhension

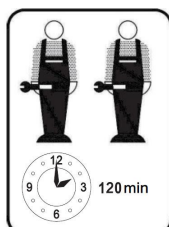

DE:Vor dem Einbau die Schrauben in die Löcher stecken und festziehen, aber nicht bis 100%, 70% bis 80% anziehen reicht aus. Schließlich, nachdem alle Schrauben installiert sind, ziehen Sie alle Schrauben auf 100%.Wenn Sie auf diese Probleme stoßen, wie z. B. Fehlausrichtung der Löcher oder Unfähigkeit, bestimmte Teile zu installieren, überprüfen Sie bitte, ob die Schrauben korrekt verwendet werden und passen Sie die Dichtigkeit der Schrauben an.

UK:Before installation, insert the screws into the holes and tighten them, but do not tighten them to 100%, 70% to 80% is sufficient. Finally, after all screws are installed, tighten all screws to 100%.If you encounter these issues, such as if the holes cannot be aligned or some parts cannot be installed, please check if the screws are used correctly and adjust the tightness of the screws.

FR:Insérer la vis dans le trou avant la fin de l'assemblage, serrer la vis, mais ne pas serrer à 100%, 70% ~ 80% est correct. Enfin, une fois que toutes les vis sont bien serrées, toutes les vis sont serrées à 100%.Si vous rencontrez ces problèmes, par exemple si les trous ne sont pas alignés ou si certaines pièces ne peuvent pas être montées, vérifiez que les vis sont utilisées correctement et Ajustez leur serrage.

English

IMPORTANT ! KEEP FOR FUTURE REFERENCE : READ CAREFULLY

- To be assembled by an adult. Assembly must be checked by an adult before use
- WARNING ! Keep all screws, small parts and plastic bags out of the reach of children
- Properly identify all parts before assembling
- Never use your item if any of its parts are broken or missing
- Should any problems arise, please contact our After Sales Service
- Manufacturer's instructions shall be followed at all times
- Care: Clean with a soft, dry cloth. In case of larger stains, carefully rub with a slightly damp, non-abrasive sponge
- Avoid the risk of fire by not placing furniture near sources of ignition or hot items
- Do not jump on the bed

Deutsch

WICHTIG ! ZUM SPÄTEREN NACHSCHLAGEN AUFBEWAHREN: SORGFÄLTIG LESEN

- Muss von einem Erwachsenen zusammengebaut werden. Der Zusammenbau muss vor dem Gebrauch von einem Erwachsenen überprüft werden
- WARNUNG! Bewahren Sie alle Schrauben, Kleinteile und Plastikbeutel außerhalb der Reichweite von Kindern auf
- Kennzeichnen Sie vor dem Zusammenbau alle Teile richtig
- Benutzen Sie Ihren Artikel niemals, wenn Teile gebrochen sind oder fehlen
- Sollten Probleme auftreten, wenden Sie sich bitte an unseren Kundendienst
- Die Anweisungen des Herstellers sind stets zu befolgen
- Pflege: Mit einem weichen, trockenen Tuch reinigen. Bei größeren Flecken vorsichtig mit einem leicht feuchten, nicht scheuernden Schwamm abreiben. nicht scheuernden Schwamm
- Vermeiden Sie die Gefahr eines Brandes, indem Sie die Möbel nicht in der Nähe von Zündquellen oder heißen Gegenständen aufstellen
- Nicht auf das Bett springen

Français

IMPORTANT ! CONSERVER POUR RÉFÉRENCE ULTÉRIEURE : LIRE ATTENTIVEMENT

- Le montage doit être effectué par un adulte. Le montage doit être vérifié par un adulte avant Utilisation
- ATTENTION ! Tenir les vis, les petites pièces et les sachets en plastique hors de portée des enfants
- Identifiez correctement toutes les pièces avant de les assembler
- N'utilisez jamais votre article si l'une de ses pièces est cassée ou manquante
- En cas de problème, veuillez contacter notre service après-vente
- Les instructions du fabricant doivent être respectées à tout moment
- Entretien : nettoyer avec un chiffon doux et sec. En cas de taches plus importantes, frotter soigneusement avec une éponge non abrasive légèrement humide. légèrement humide et non Abrasive
- Évitez les risques d'incendie en ne plaçant pas les meubles à proximité de sources d'inflammation ou d'objets chauds
- Ne pas sauter sur le lit

Italiano

IMPORTANTE! CONSERVARE PER RIFERIMENTO FUTURO: LEGGERE ATTENTAMENTE

- Deve essere assemblato da un adulto. L'assemblaggio deve essere controllato da un adulto prima dell'uso
- **ATTENZIONE!** Tenere tutte le viti, le piccole parti e i sacchetti di plastica fuori dalla portata dei bambini
- Identificare correttamente tutte le parti prima dell'assemblaggio
- Non utilizzare mai l'articolo se alcune parti sono rotte o mancanti
- In caso di problemi, si prega di contattare il nostro Servizio Post Vendita
- Le istruzioni del produttore devono essere sempre seguite
- Cura: Pulire con un panno morbido e asciutto. In caso di macchie più estese, strofinare accuratamente con una spugna leggermente umida e non abrasiva
- Evitare il rischio di incendio, non collocando i mobili vicino a fonti di accensione o a oggetti caldi
- Non saltare sul letto

Español

¡ IMPORTANTE ! CONSERVELO PARA FUTURAS CONSULTAS: LEA ATENTAMENTE

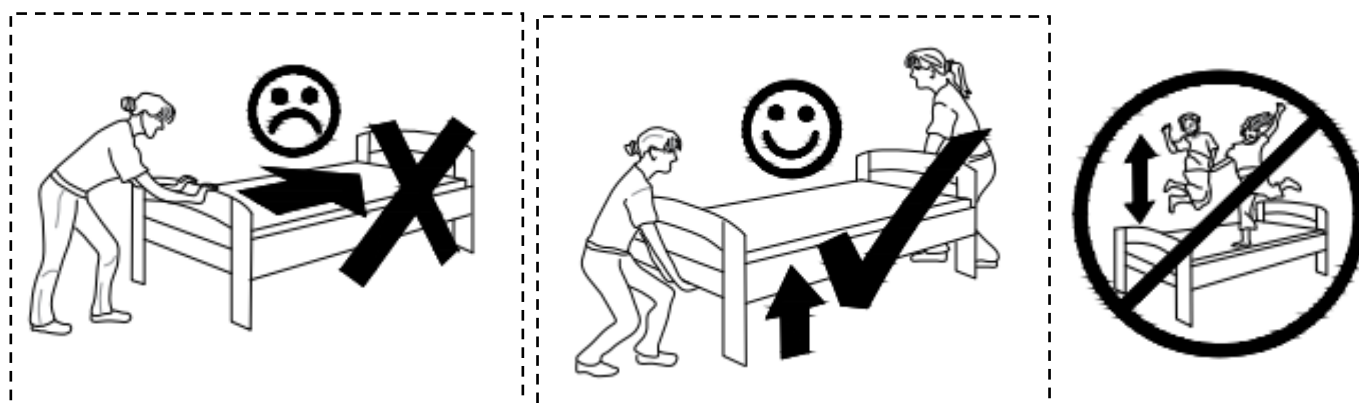

- Debe ser montado por un adulto. El montaje debe ser comprobado por un adulto antes del uso
- ADVERTENCIA Mantenga todos los tornillos, piezas pequeñas y bolsas de plástico fuera del alcance de los niños.
- Identifique correctamente todas las piezas antes de montarlas
 - Nunca utilice su artículo si alguna de sus piezas está rota o falta
 - Si surge algún problema, póngase en contacto con nuestro Servicio Postventa
 - Las instrucciones del fabricante deben seguirse en todo momento
 - Cuidado: Limpiar con un paño suave y seco. En caso de manchas más grandes, frote cuidadosamente con una esponja no abrasiva ligeramente humedecida.
 - Evite el riesgo de incendio no colocando los muebles cerca de fuentes de ignición u objetos calientes.
 - No saltar sobre la cama.

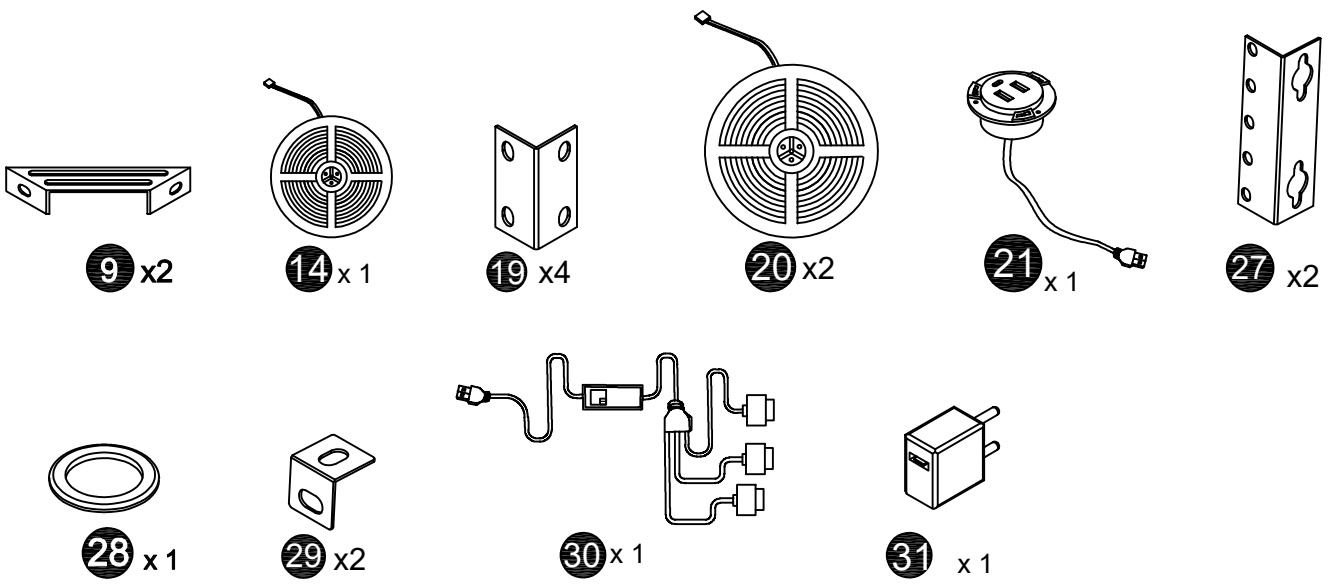
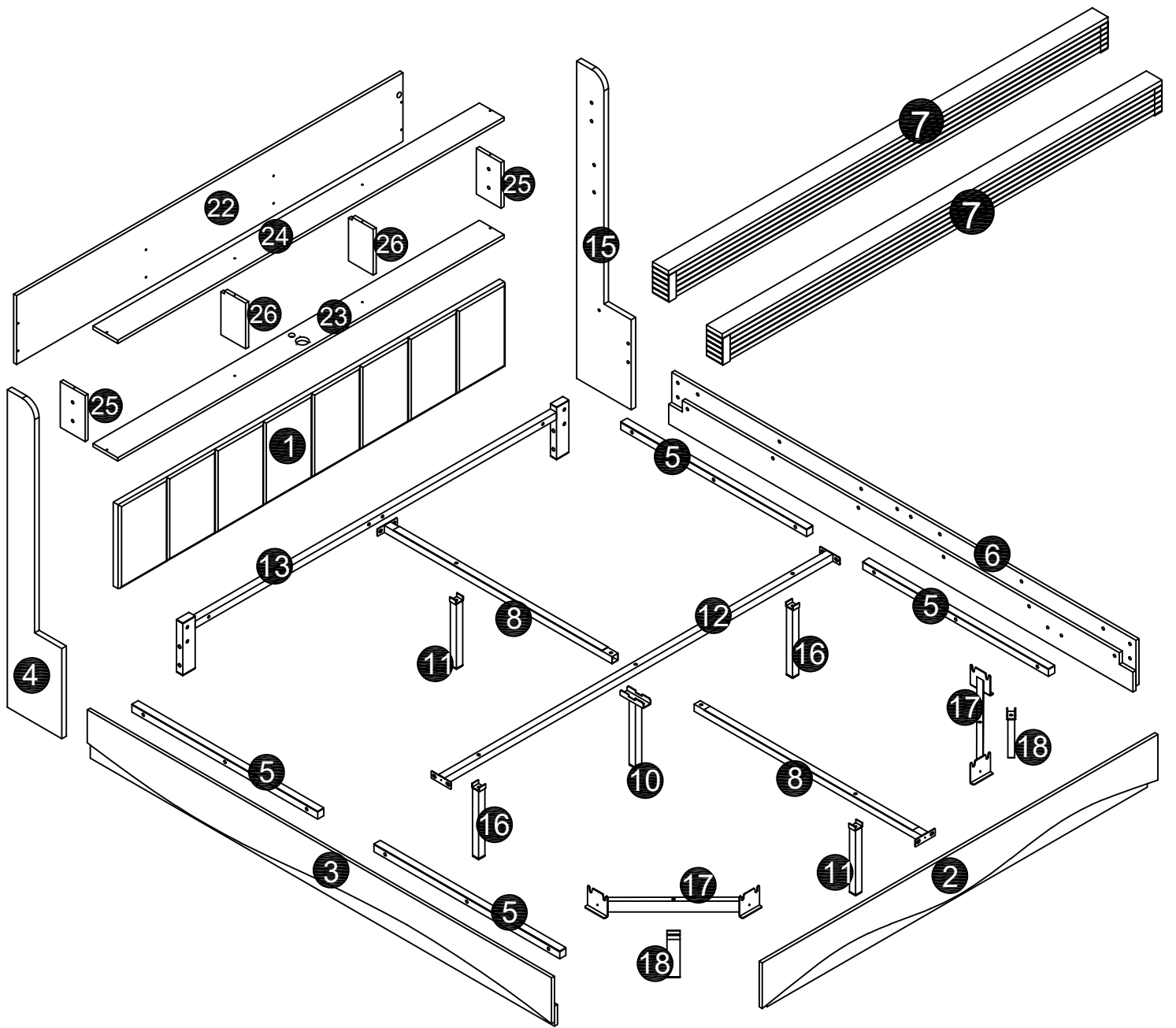





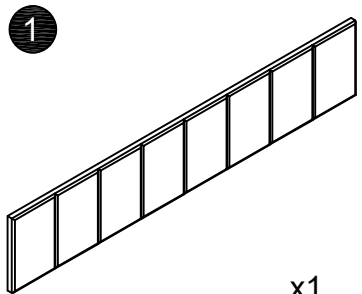
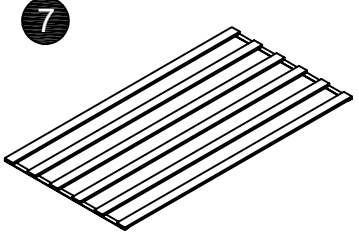
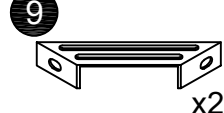
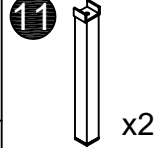
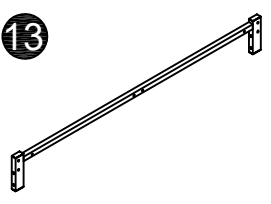
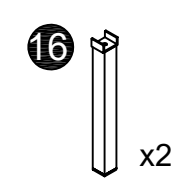

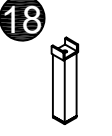
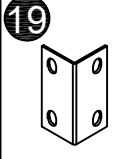
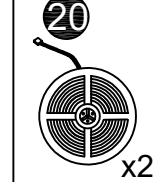
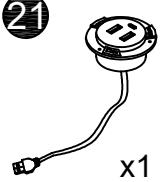
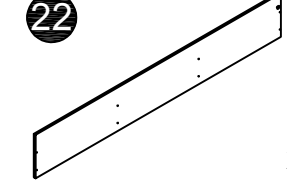
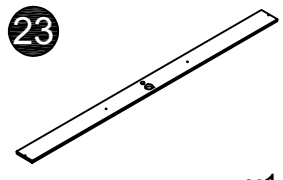
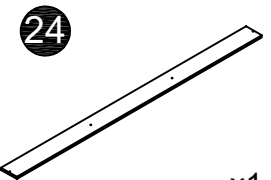
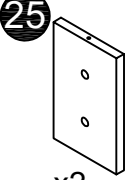
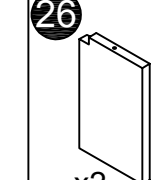
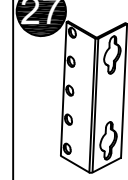
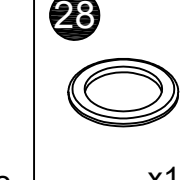
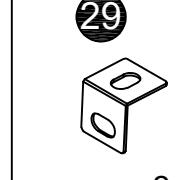
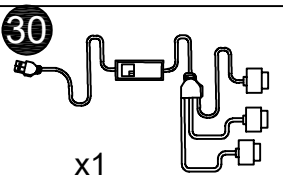
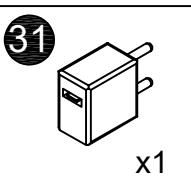





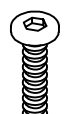
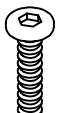

Part list - Teileliste - Liste des pièces

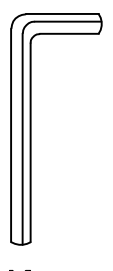

N623P225502 / N623P225500

 1 x1	 7 x2	 9 x2	 11 x2	 13 x1		
 16 x2	 17 x2	 18 x2	 19 x4	 20 x2	 21 x1	 22 x1
 23 x1	 24 x1	 25 x2	 26 x2	 27 x2	 28 x1	 29 x2
 30 x1	 31 x1					

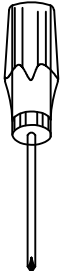
Hardware list - Hardwareliste - Liste de matériel

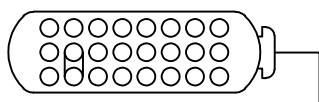
N623P225502 / N623P225500

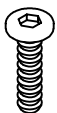
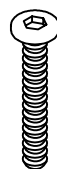
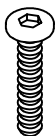
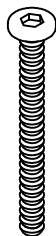

 A M8x20 x 8	 B M8x25 x 6	 C M8x37 x 18	 D M8x32 x 4	 E M8x70 x 7	 F x 10	 G M6x40 x 16	 H M8x14 x 26	 I M6x20 x 6
 J M8 x 1	 K M6 x 1	 L x 3	 N x 1	 O M6x11 x 2	 P x 4	 M x 1 <div style="border: 1px solid black; padding: 5px; margin-top: 10px;"> <p>Unplug the battery separator of the remote control before use Trennen Sie den Akku separator der Fernbedienung Kontrolle vor Gebrauch Débranchez la batterie Séparateur de télécommande Contrôle avant utilisation</p> </div>		

 A M8x20 x 8	 B M8x25 x 6	 C M8x37 x 18	 D M8x32 x 4	 E M8x70 x 7	 H M8x14 x 26	
---	---	--	---	---	--	--

DE:Bitte beachten Sie, dass die Formen der Schrauben A und B und C und D und E und H ähnlich sind. Bitte installieren Sie entsprechend der Anleitung und unterscheiden Sie sie!

UK:Please note that the shapes of screws A and B and C and D and E and H are Esimilar.Please install according to the instructions and distinguish them!

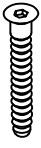
FR:Notez que les formes des vis A et B et C et D et E et H sont similaires.Suivez les instructions pour les installer et les différencier!

 G M6x40 x 16	 I M6x20 x 6	 O M6x11 x 2
--	---	---

DE:Bitte beachten Sie, dass die Formen der Schrauben G und I und O ähnlich sind. Bitte installieren Sie entsprechend der Anleitung und unterscheiden Sie sie!

UK:Please note that the shapes of screws G and I and O are Esimilar. Please install according to the instructions and distinguish them!

FR:Notez que les formes des vis G et I et O sont similaires.Suivez les instructions pour les installer et les différencier!

Part list - Teilleiste - Liste des pièces

N623P225503 / N623P225501

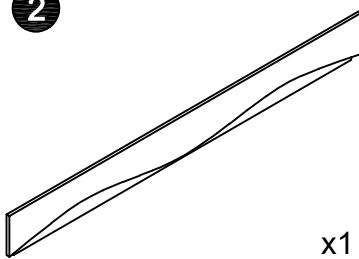
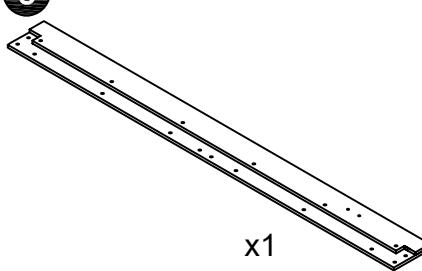
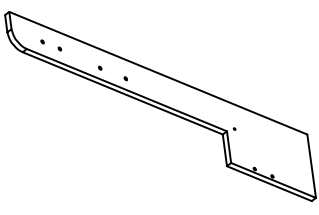
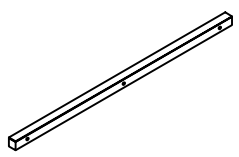
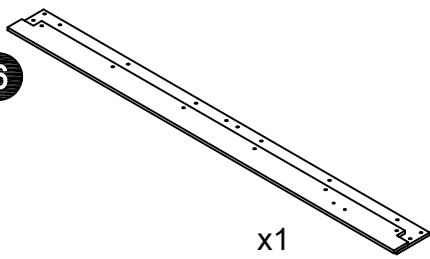
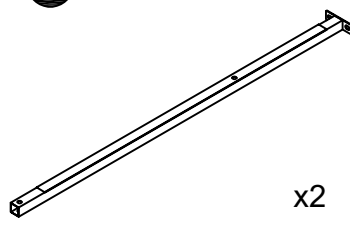
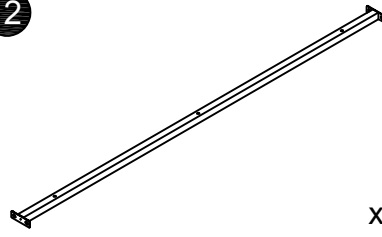
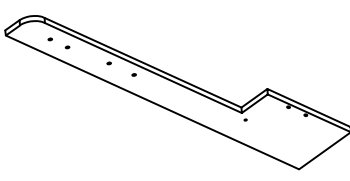
<p>2</p>  <p>x1</p>	<p>3</p>  <p>x1</p>	<p>4</p>  <p>x1</p>	<p>5</p>  <p>x4</p>
<p>6</p>  <p>x1</p>	<p>8</p>  <p>x2</p>	<p>12</p>  <p>x1</p>	
<p>15</p>  <p>x1</p>			

Step 1:

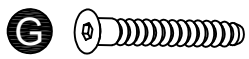

x 8

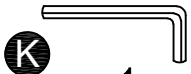

x 1

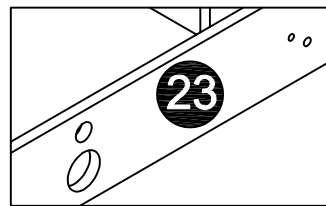
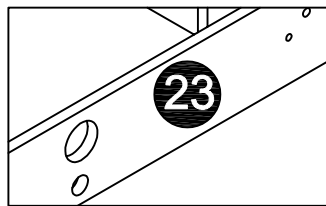
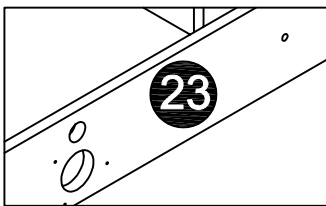
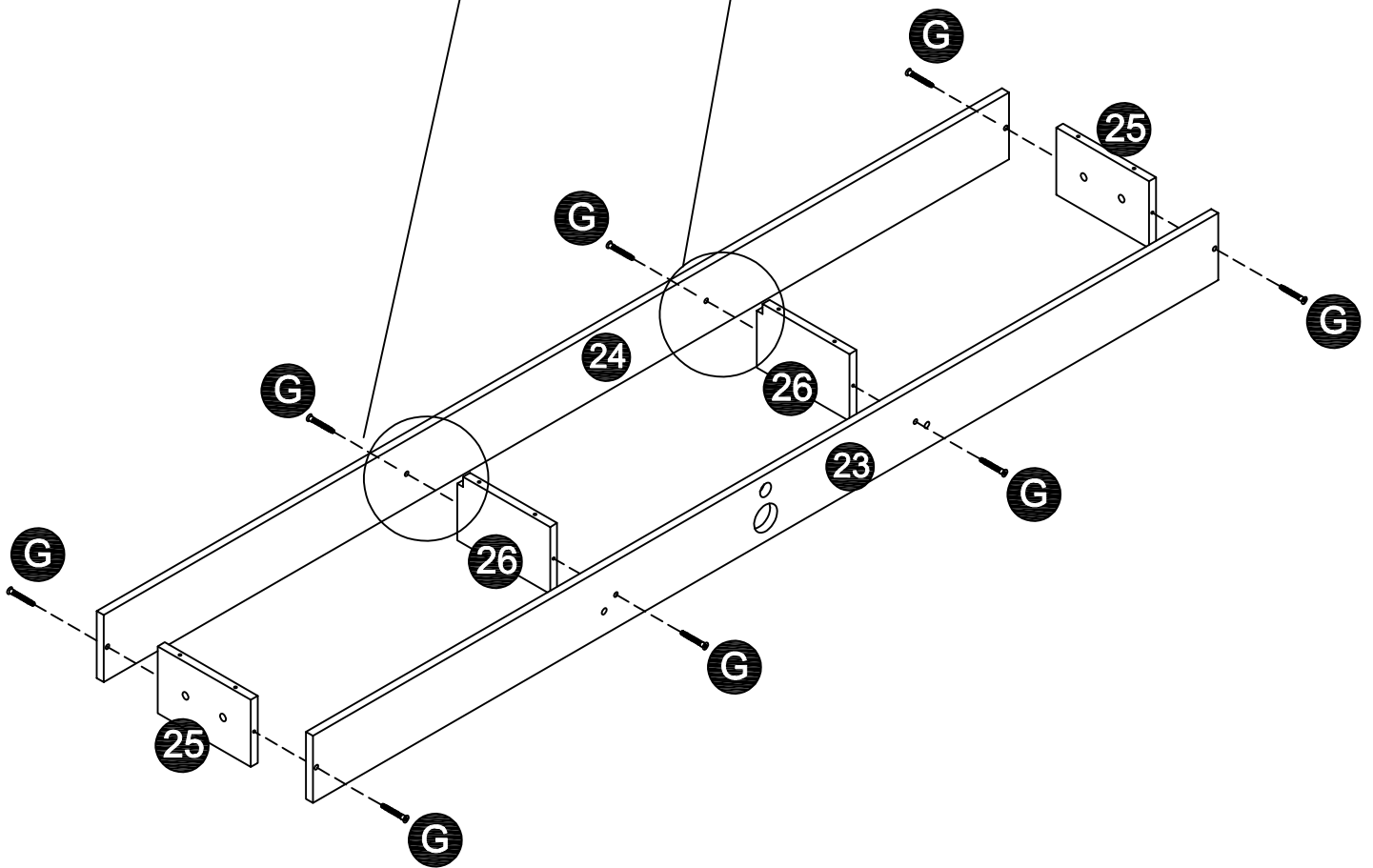
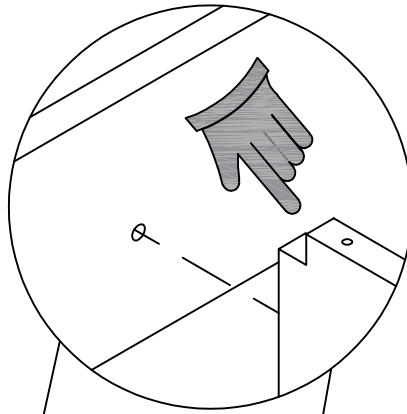

Step 2:

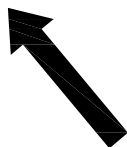
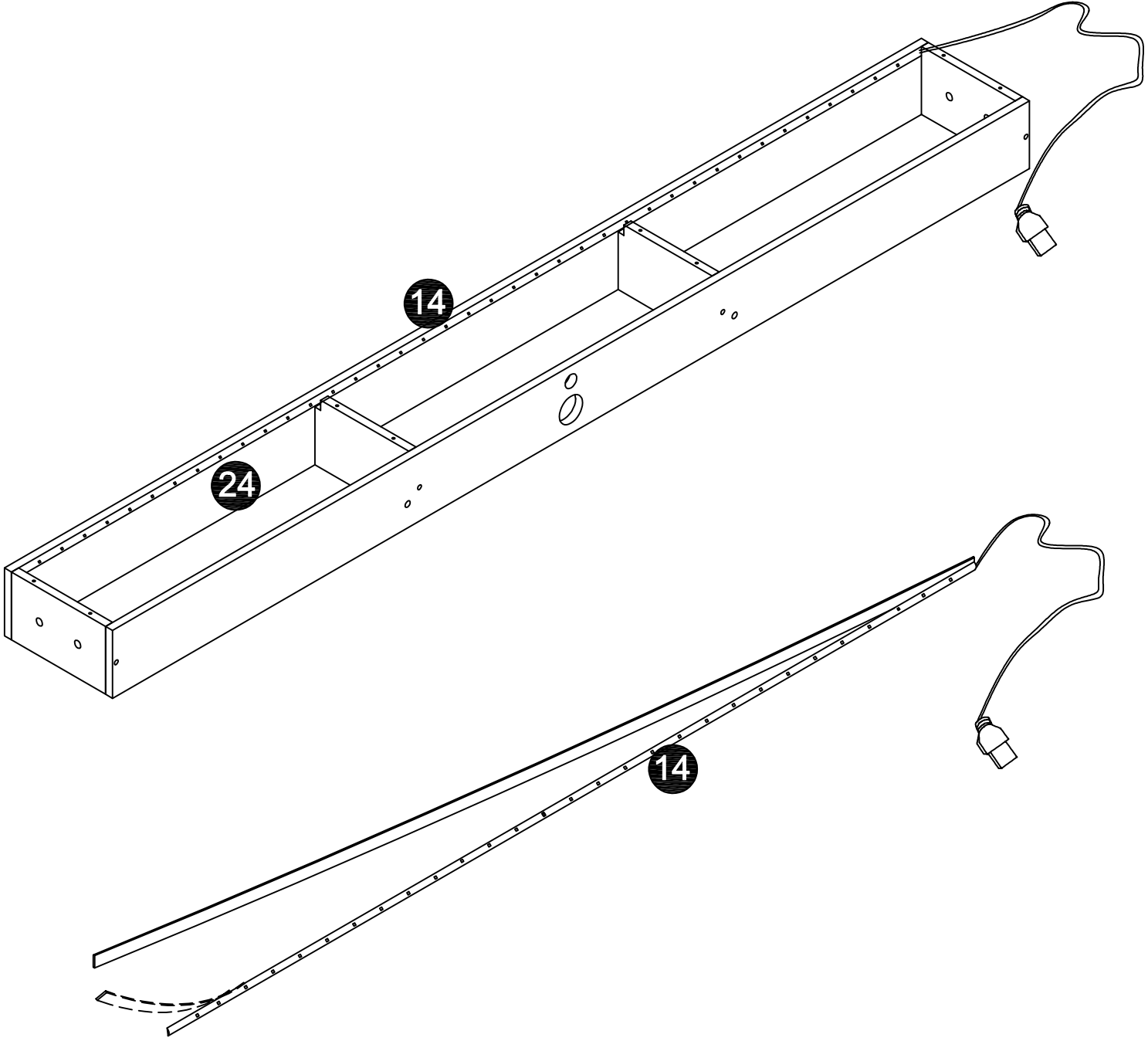
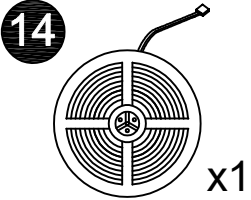

Step 3:

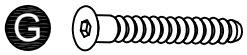

x 8

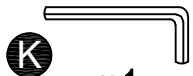

x 1

come through the hole
(durch das Loch kommen)
(Perceur hors du trou)

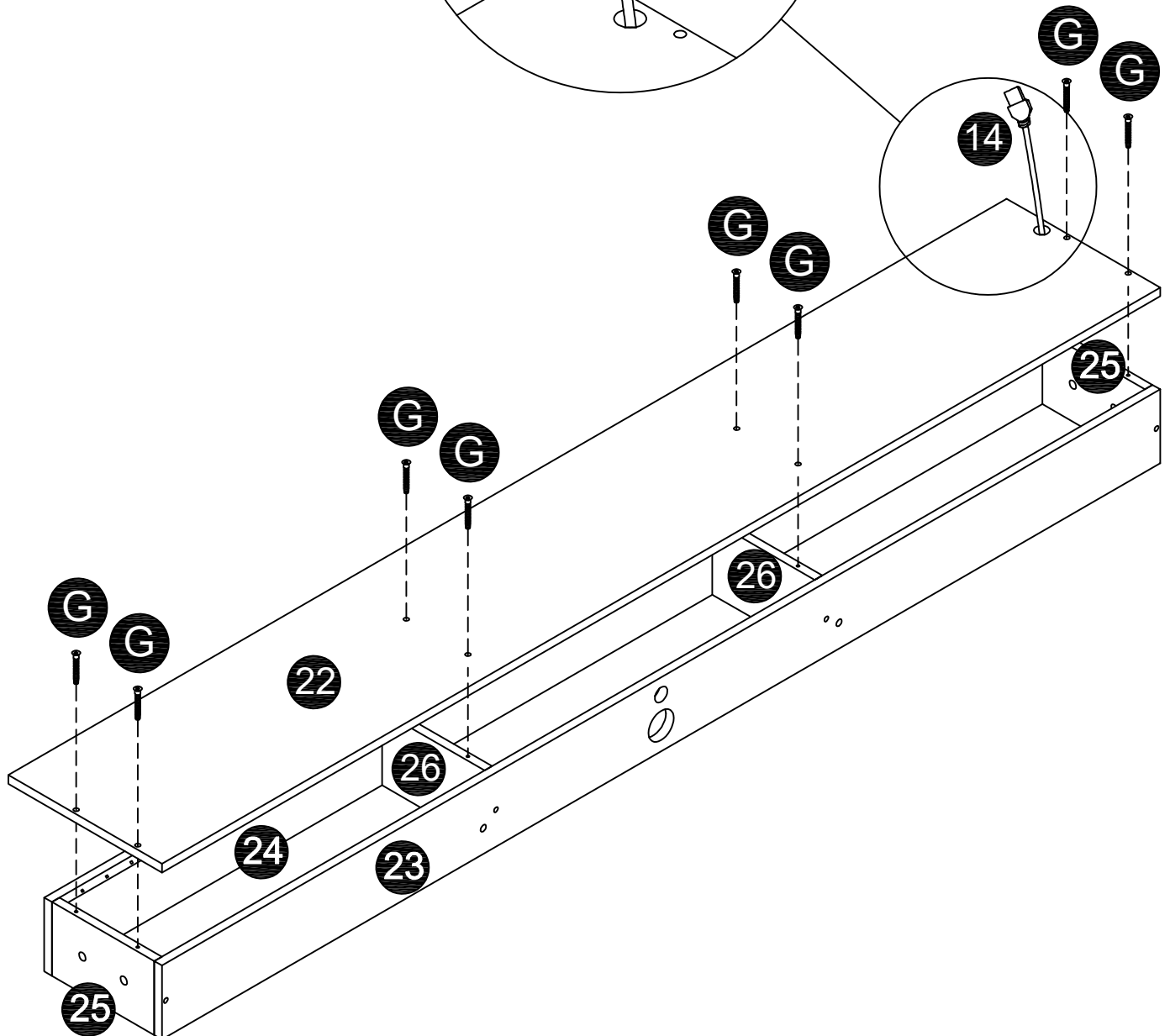
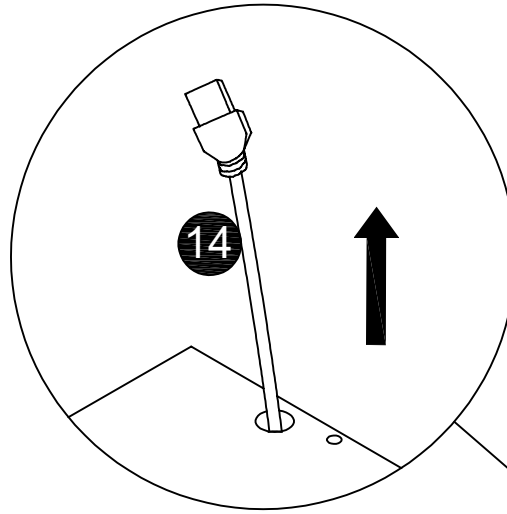

Step 4:

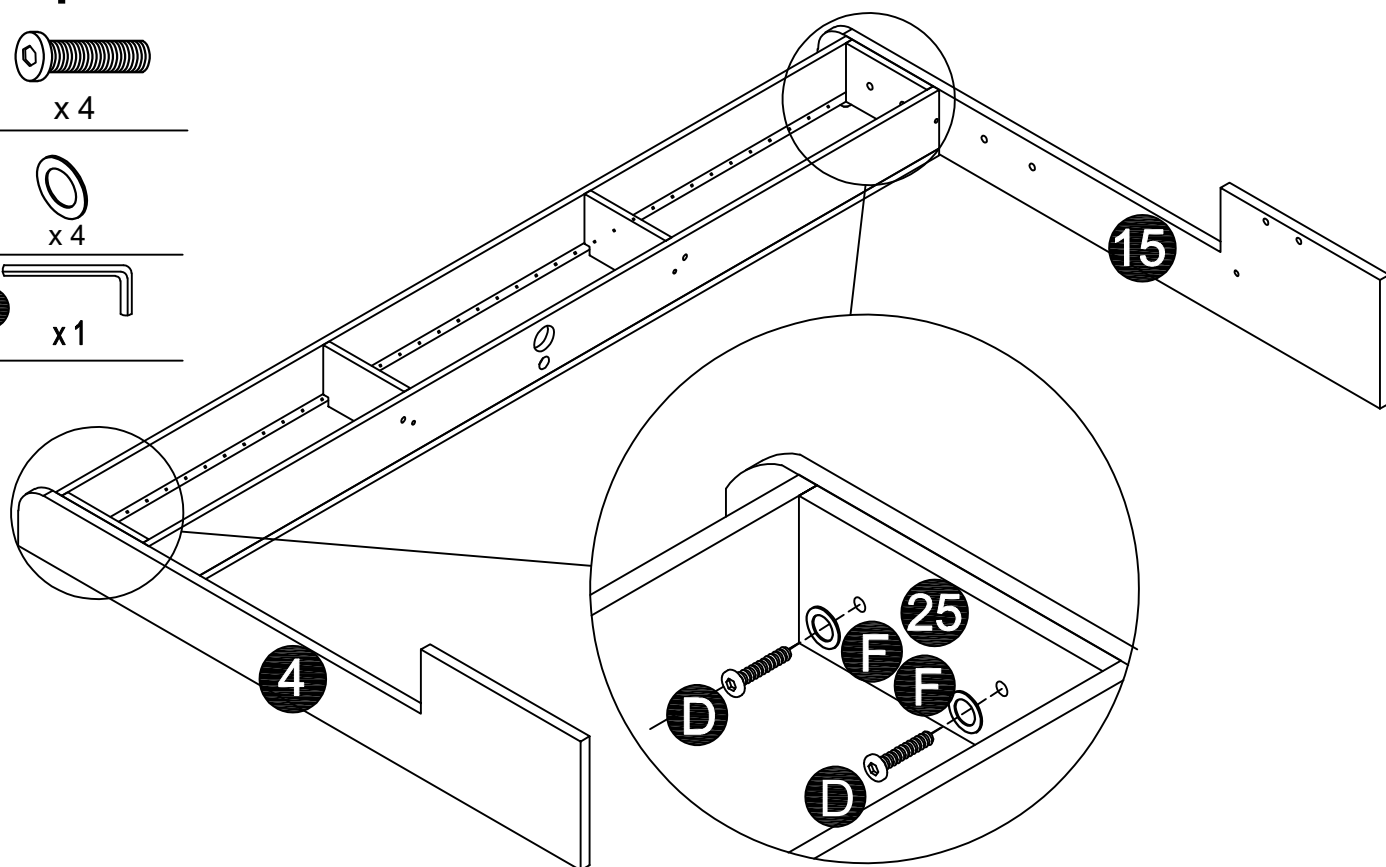
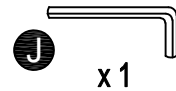
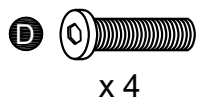

Step 5:

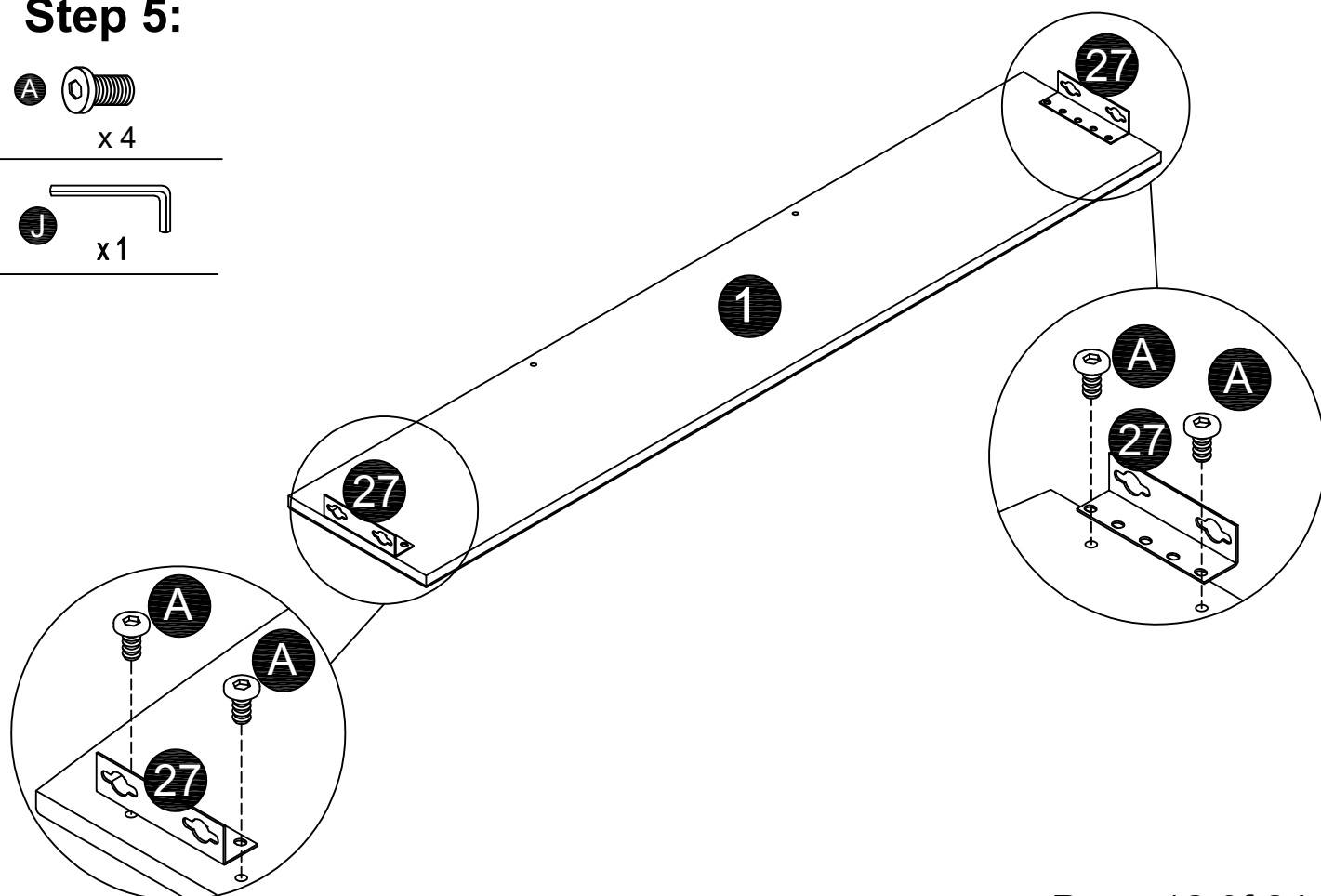
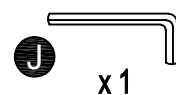
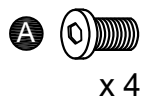

Step 6:

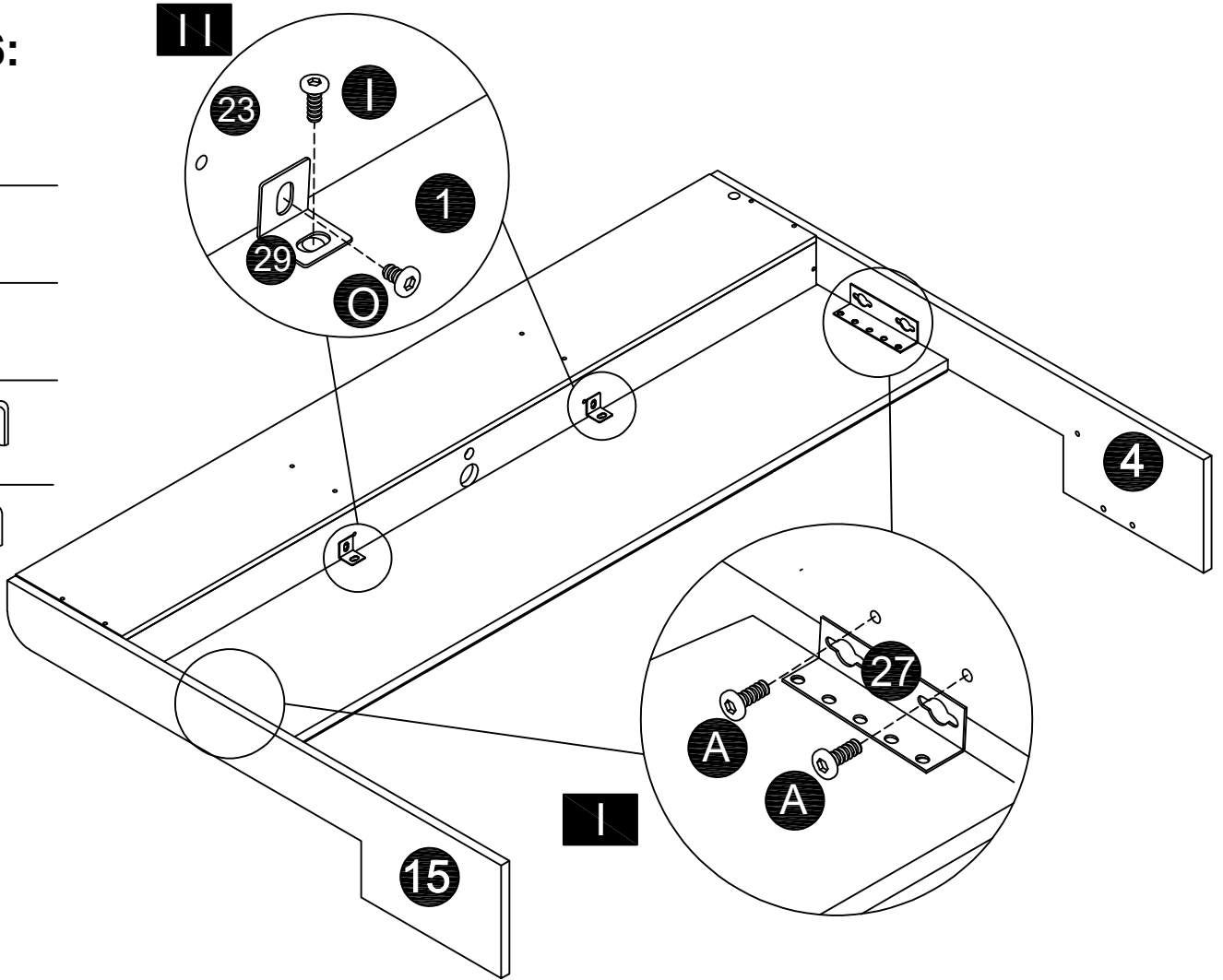
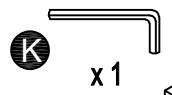
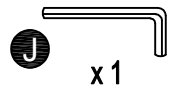
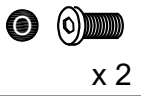
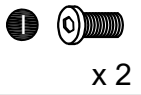
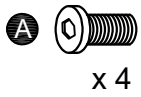

Step 7:

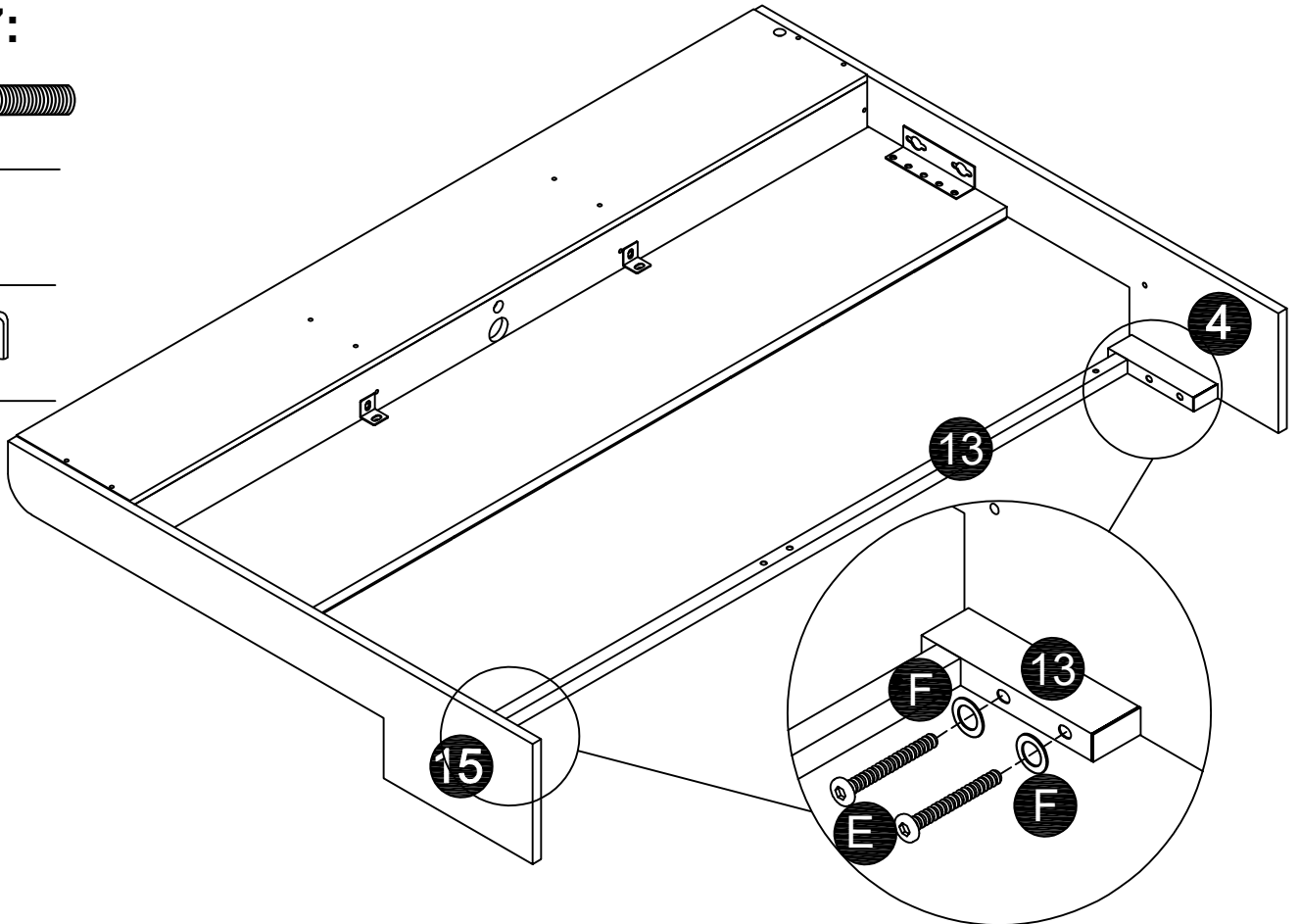
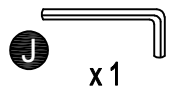
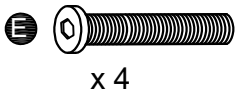

Step 8:

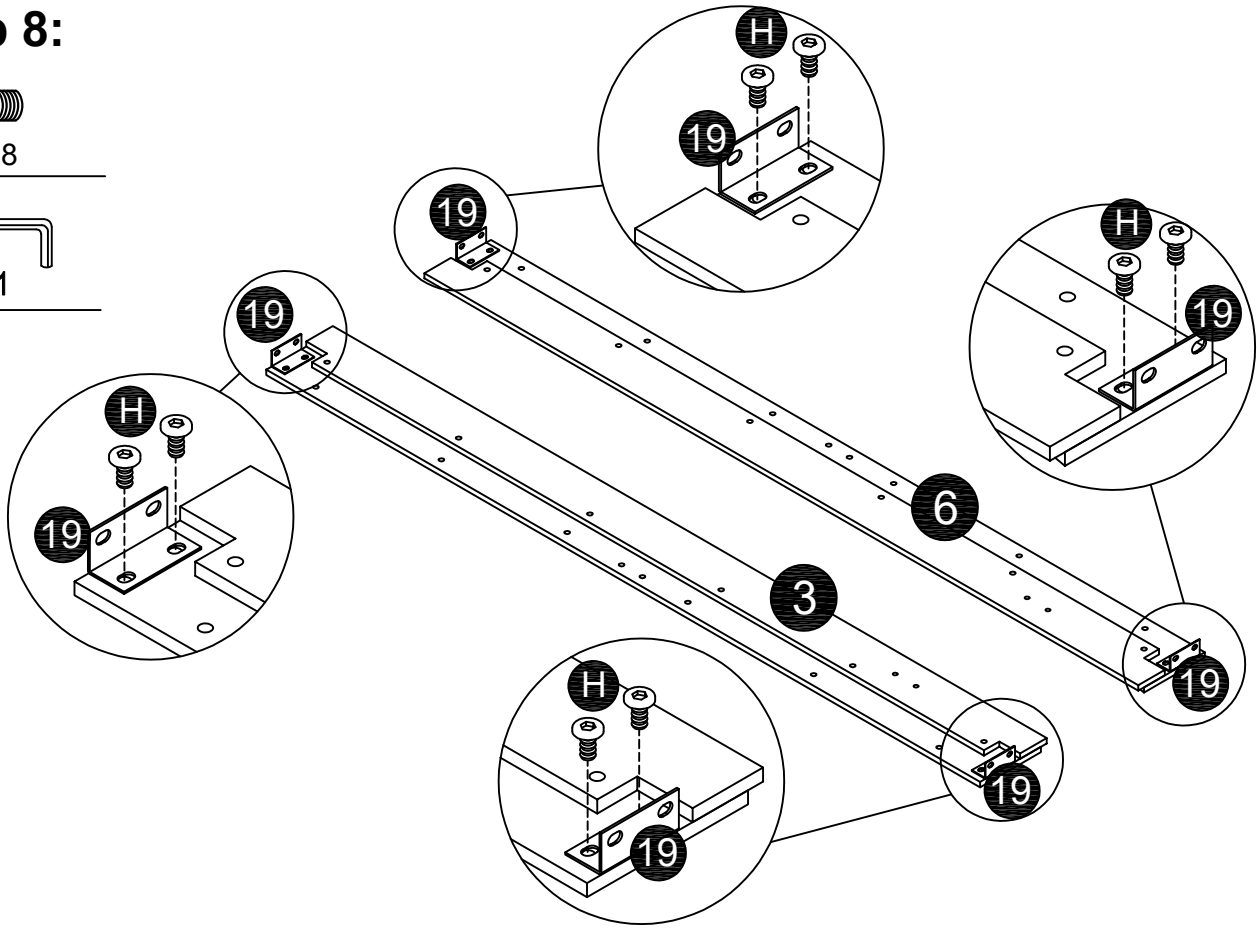
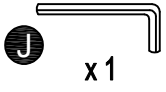
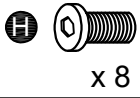

Step 9:

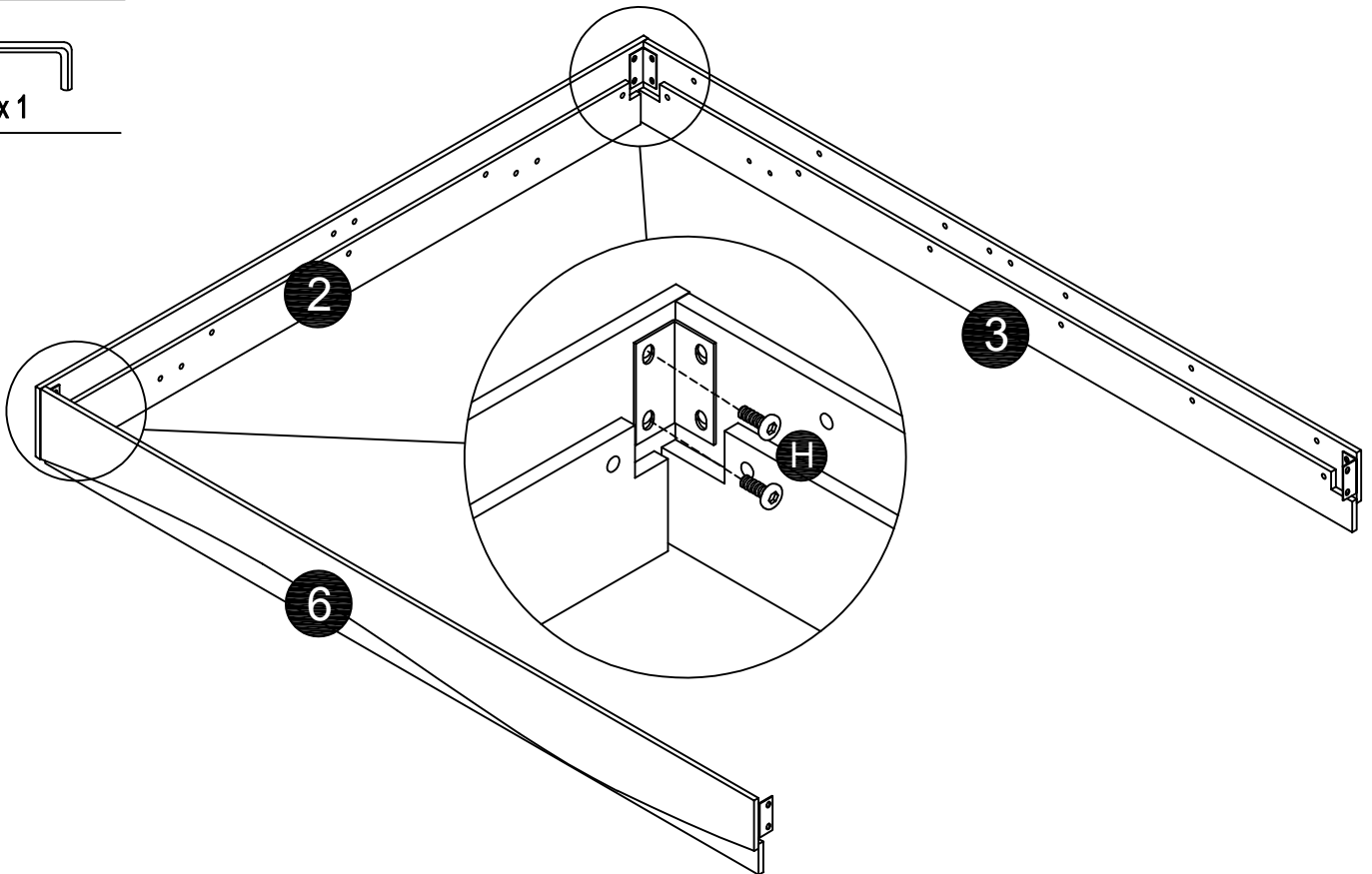
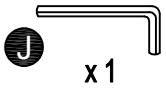
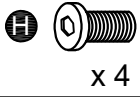

Step 10:

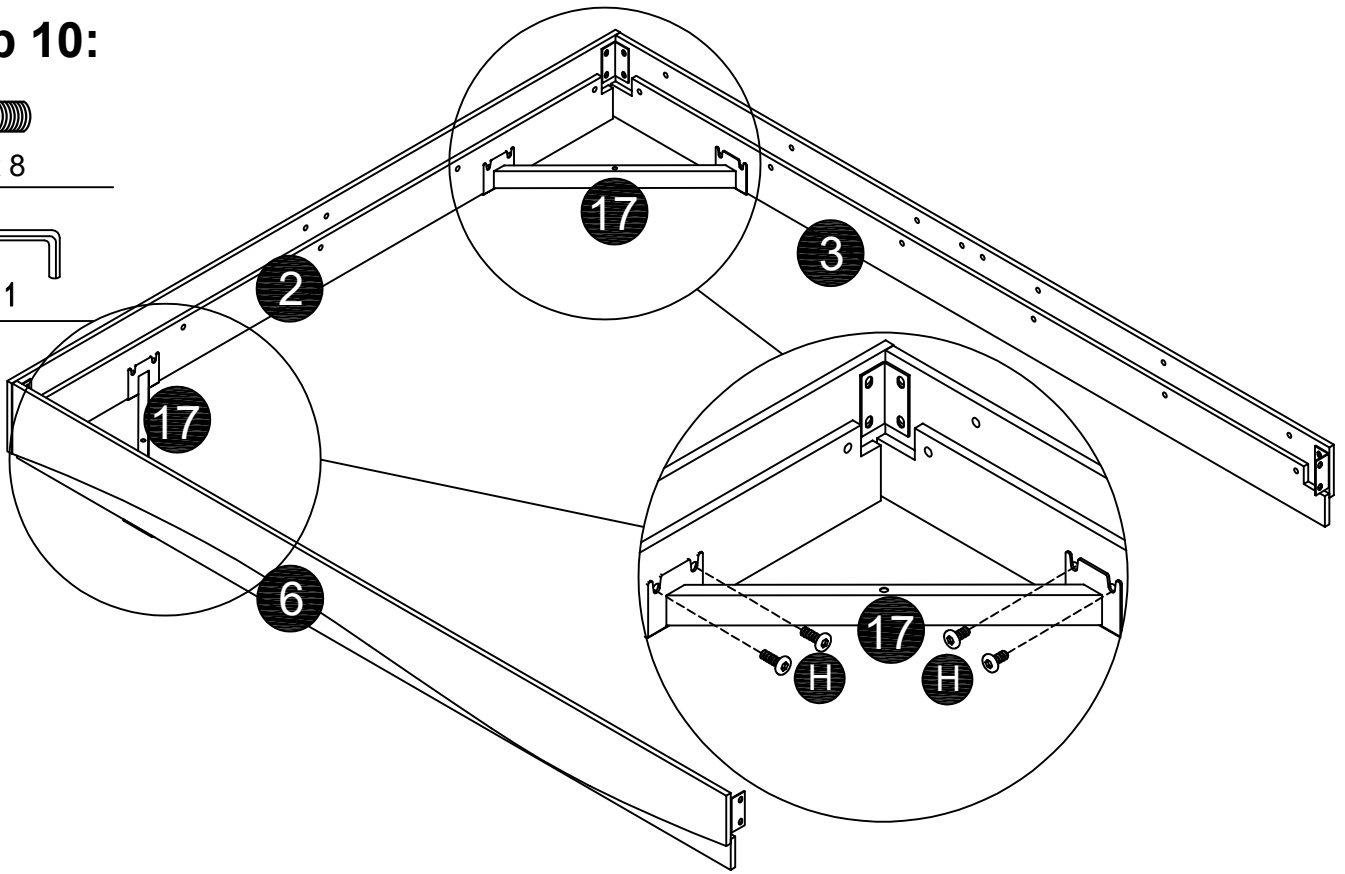
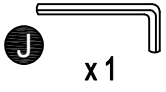
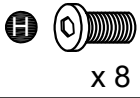

Step 11:

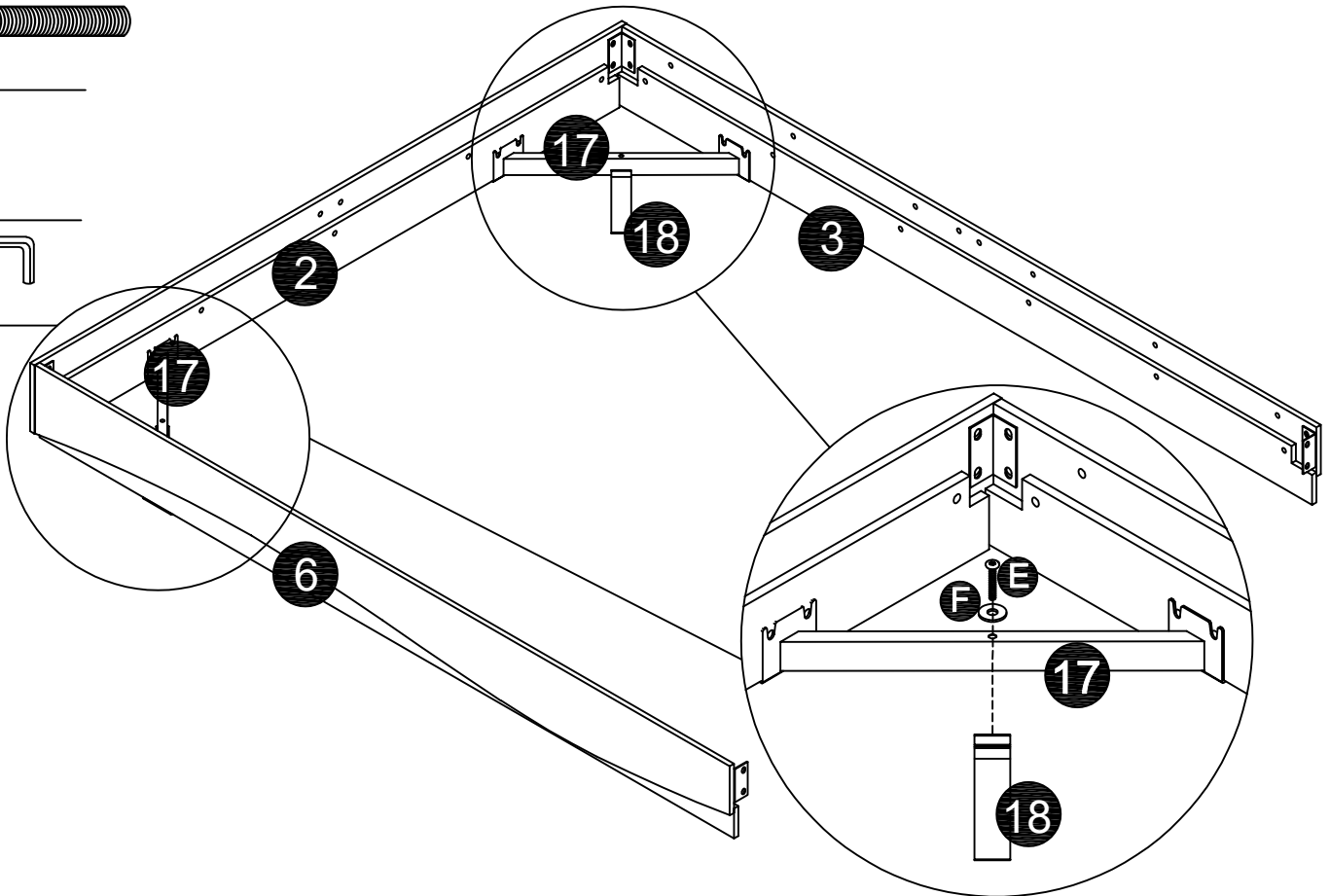
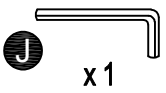
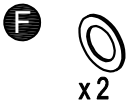
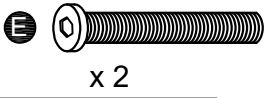

Step 12:

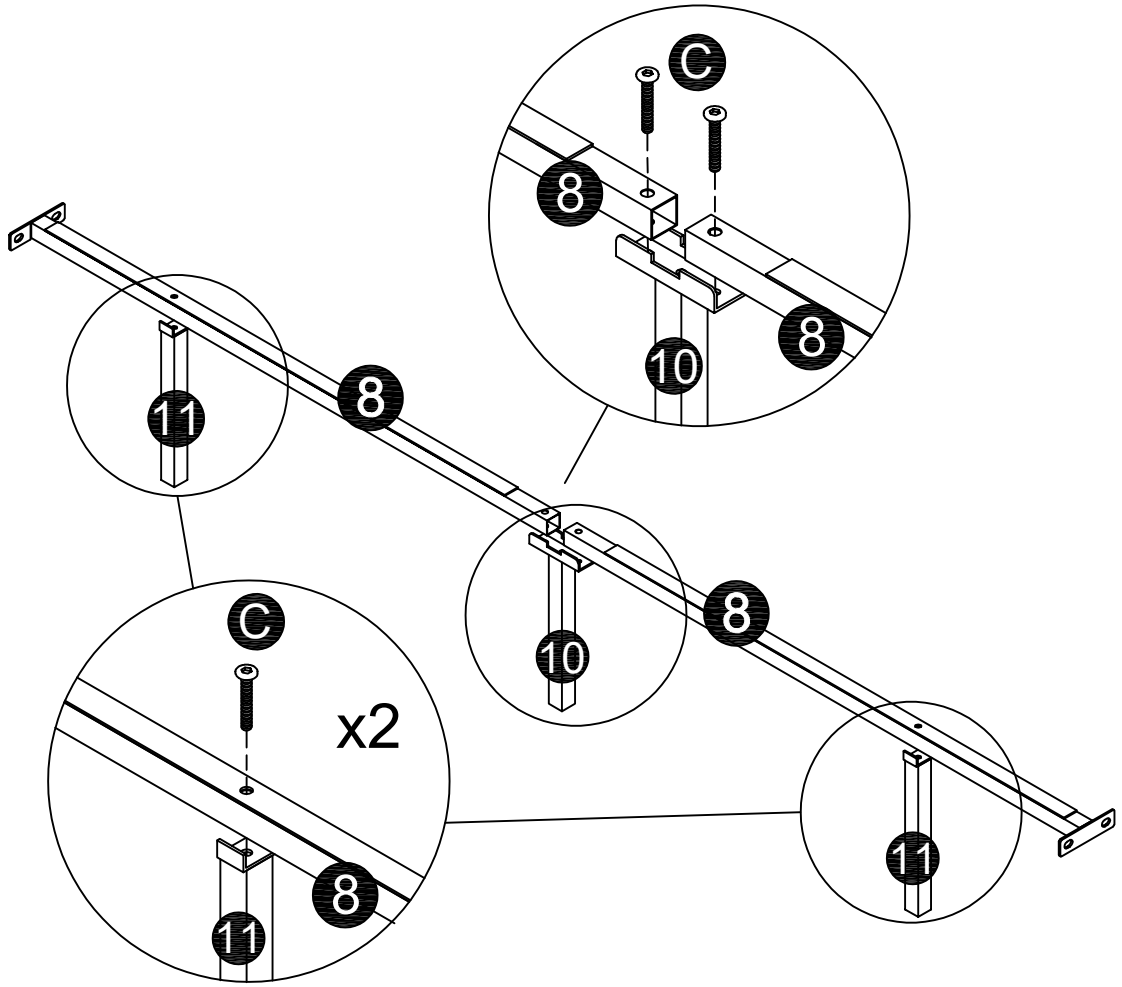
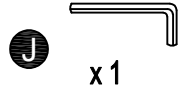
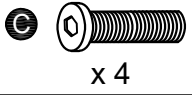

Step 13:

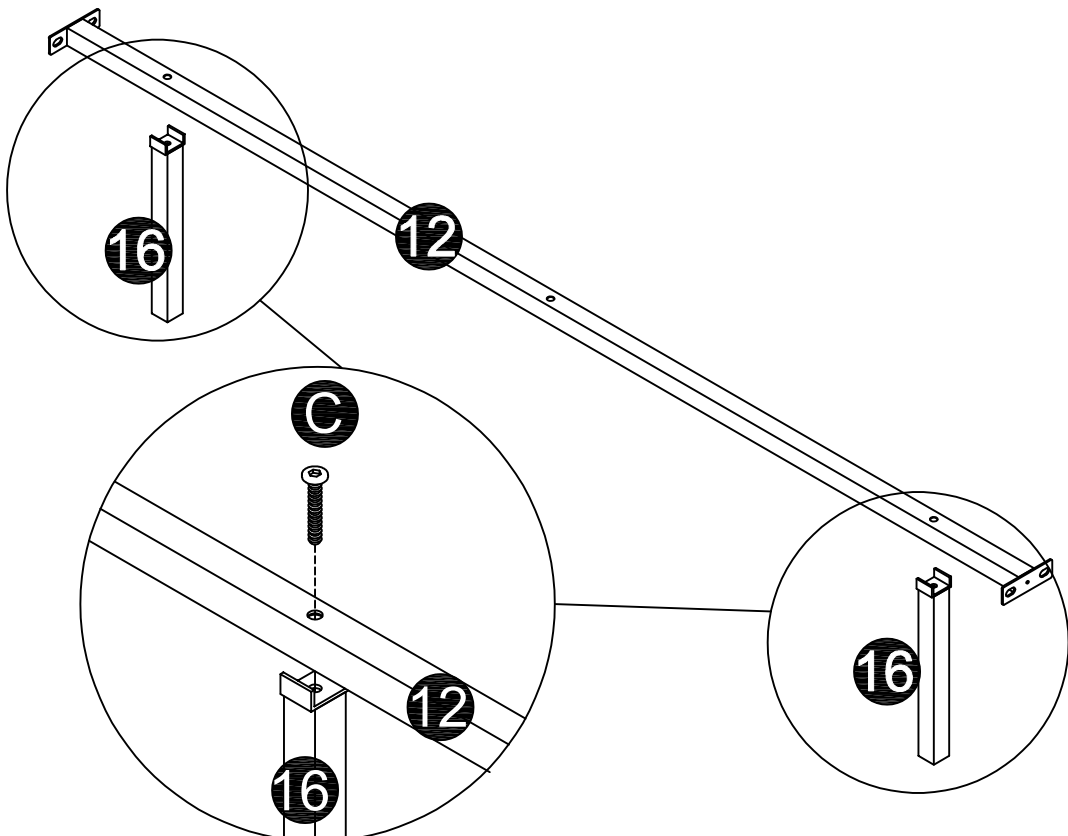
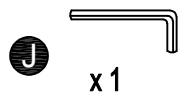
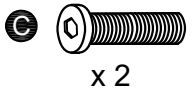

Step 14:

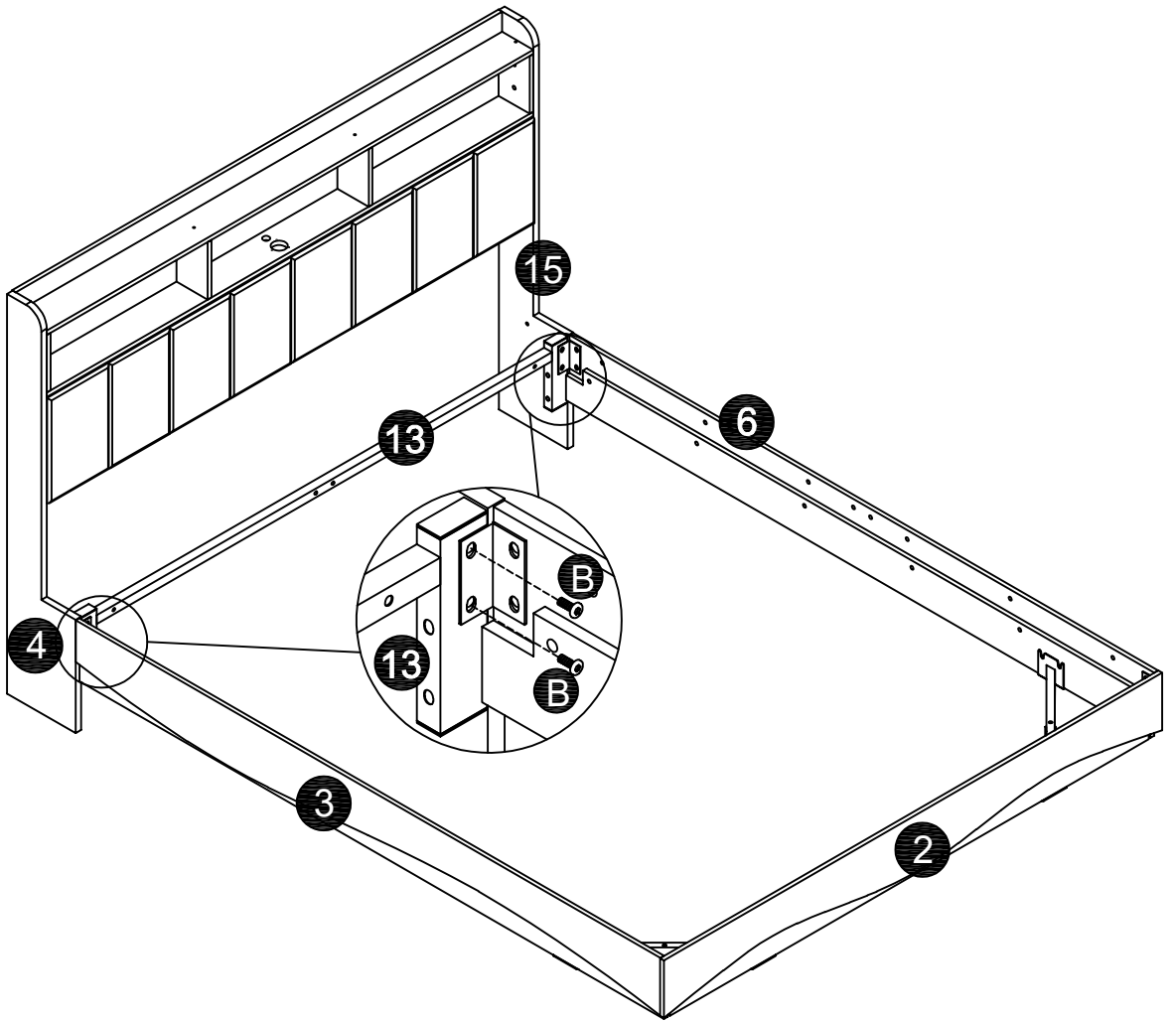
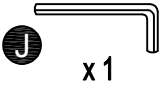
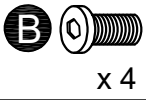

Step 15:

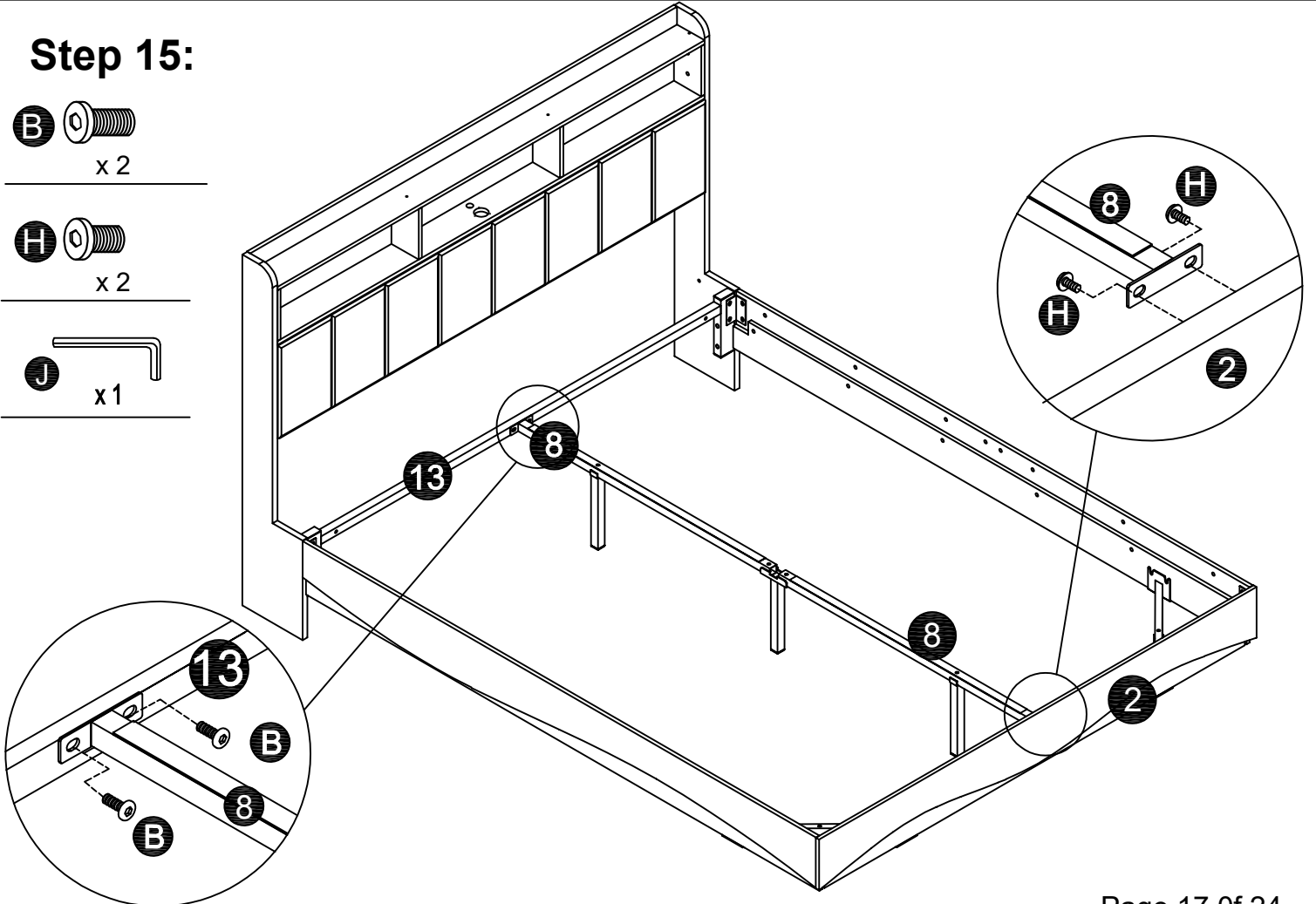
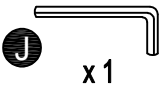
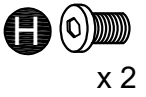
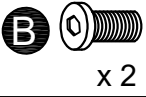

Step 16:

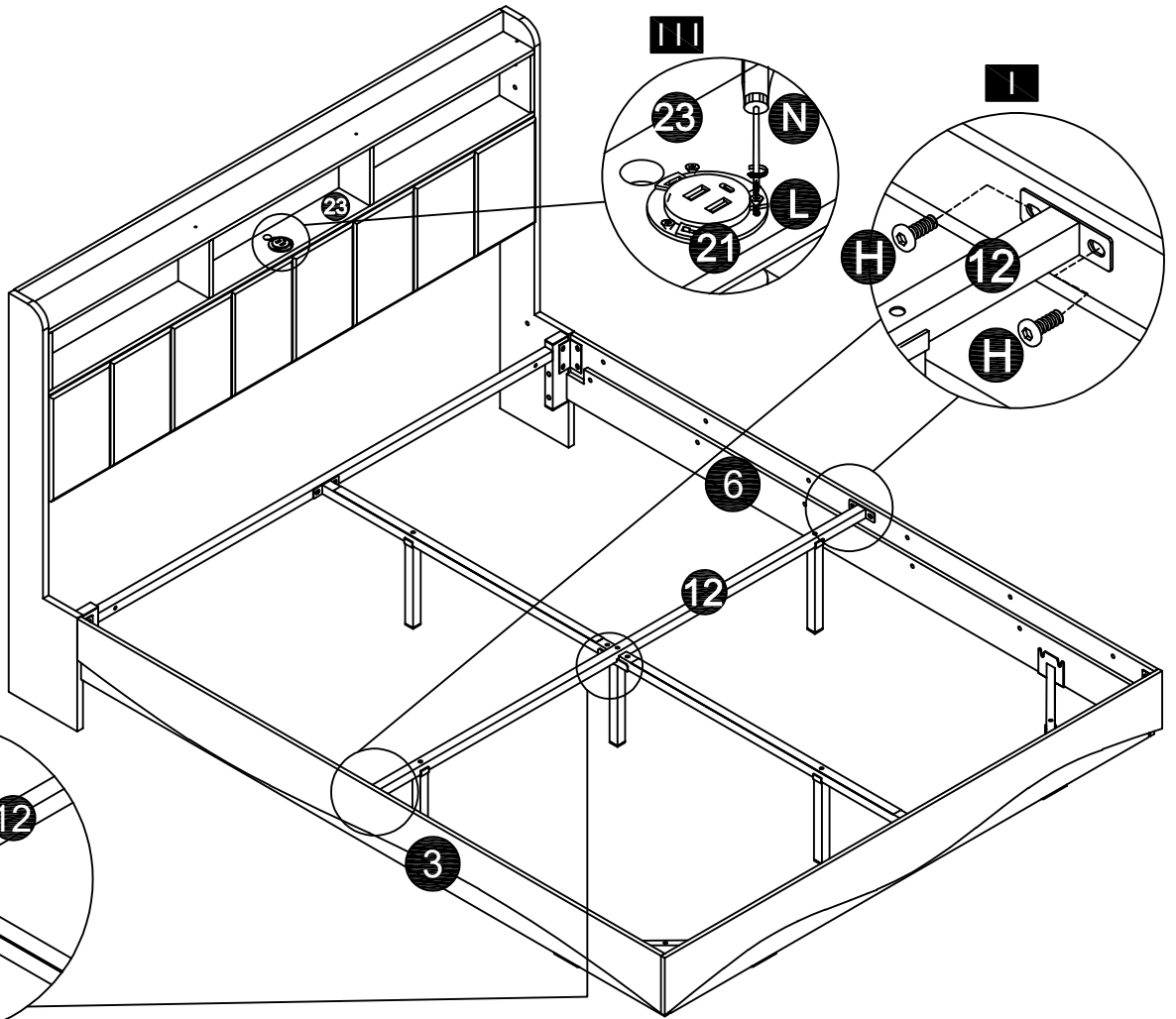
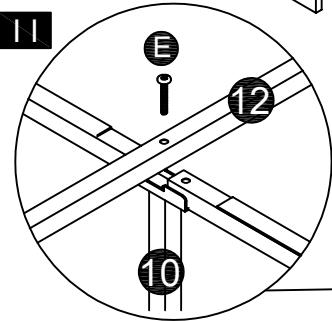
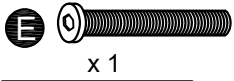
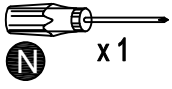
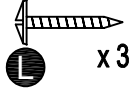
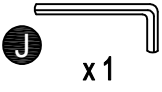
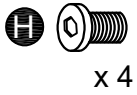

Step 17:

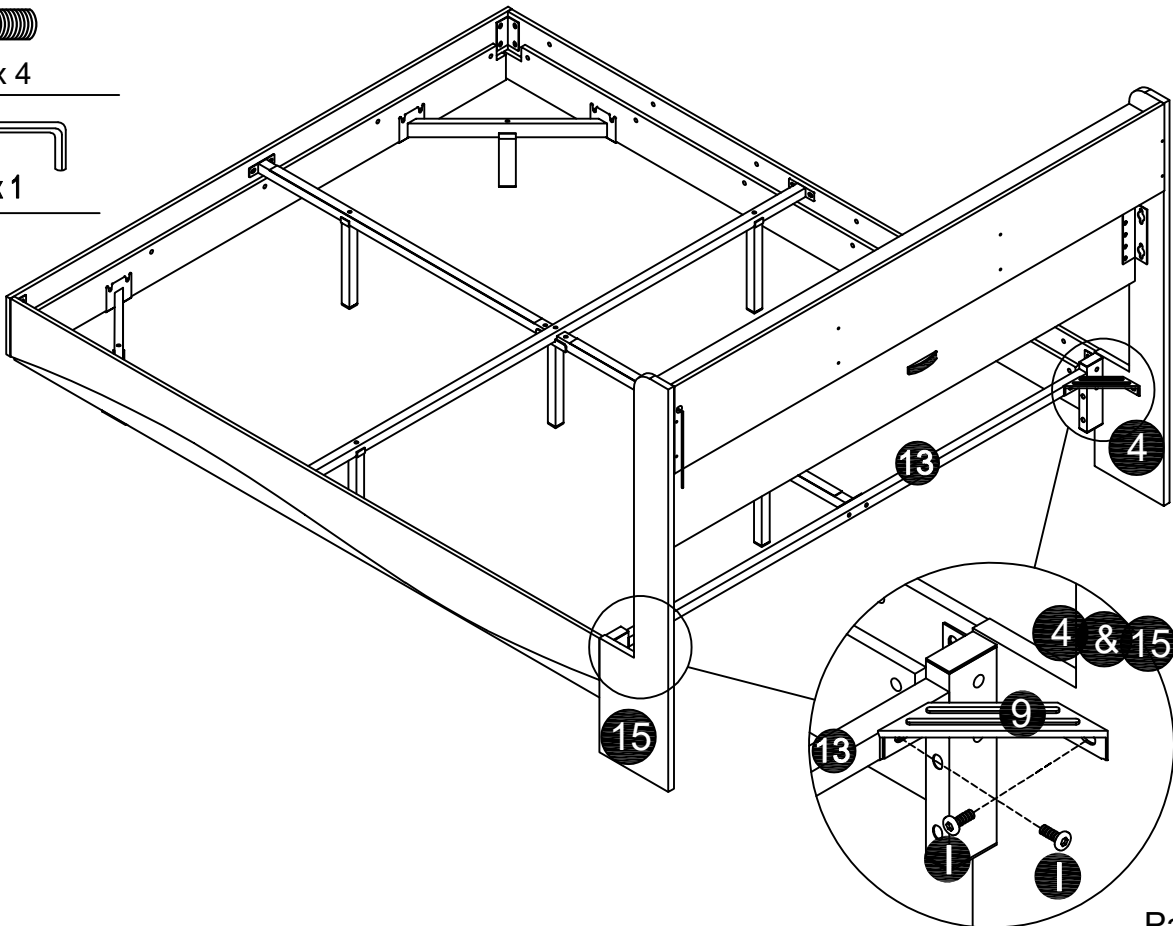
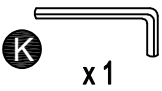
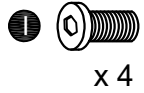

Step 18:

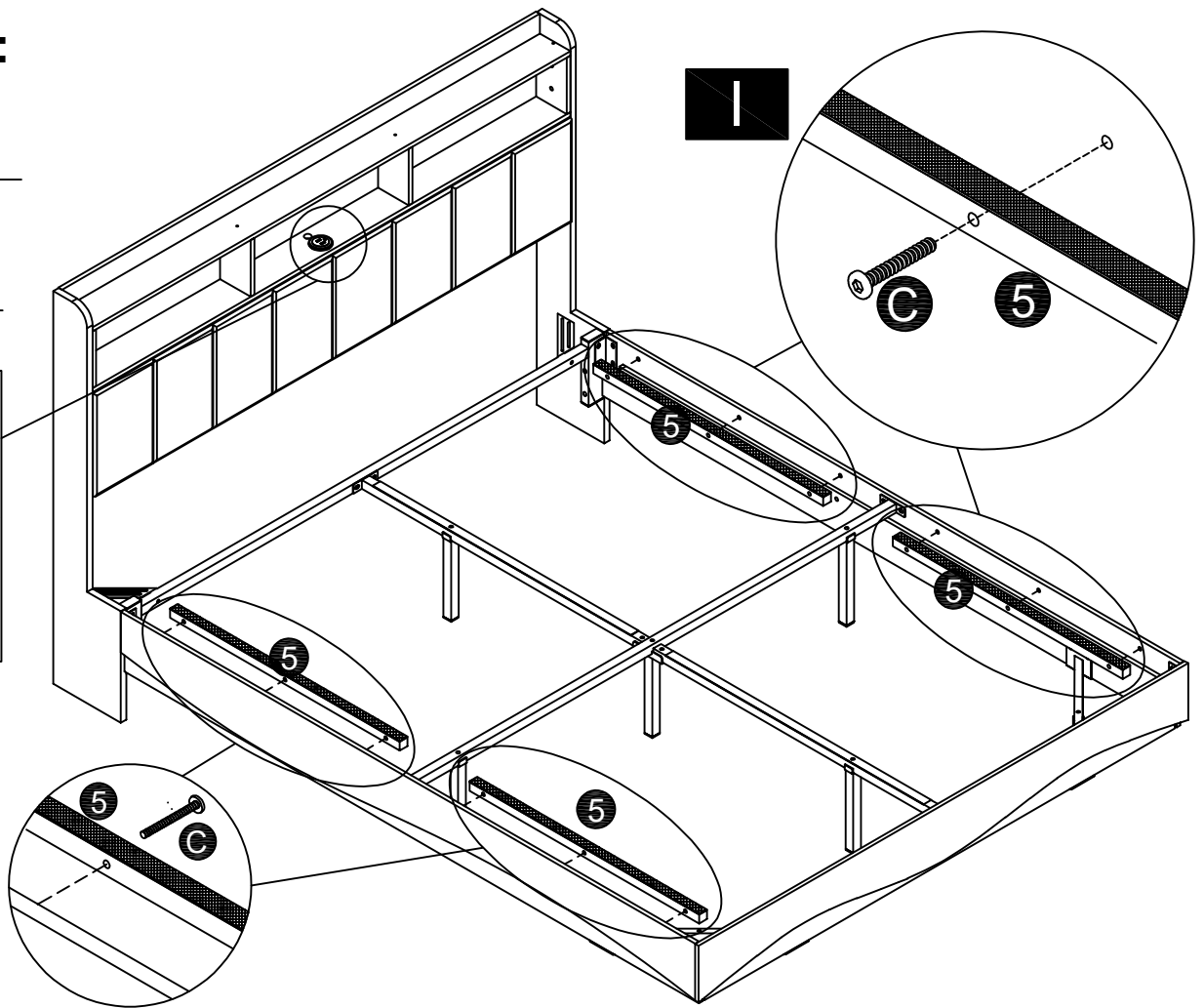
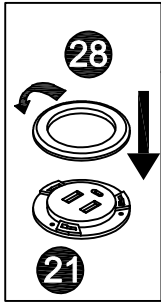
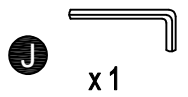
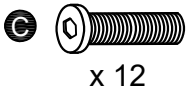

Step 19:

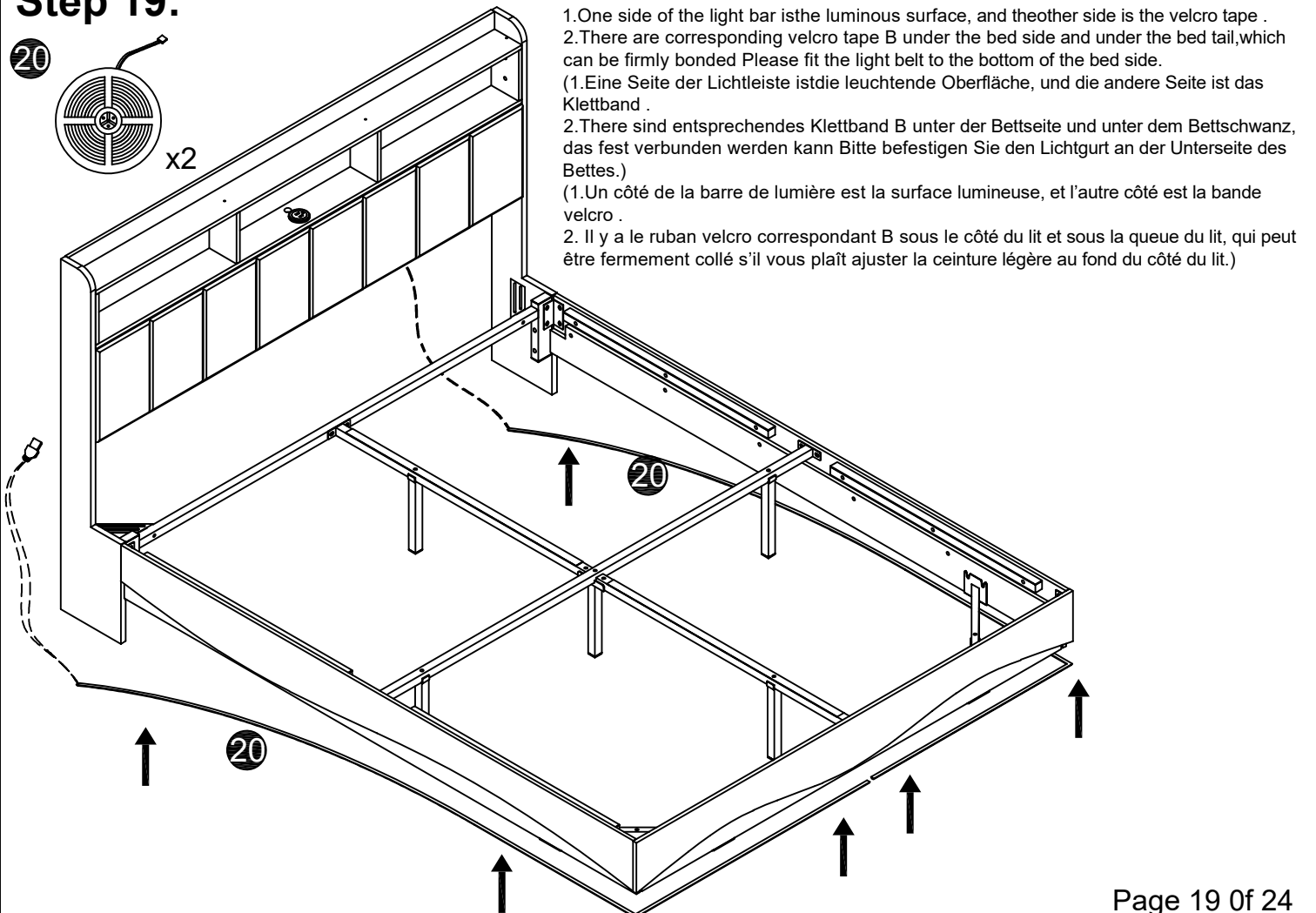
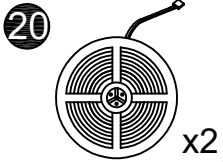

1. One side of the light bar is the luminous surface, and the other side is the velcro tape .

2. There are corresponding velcro tape B under the bed side and under the bed tail, which can be firmly bonded. Please fit the light belt to the bottom of the bed side.

(1. Eine Seite der Lichtleiste ist die leuchtende Oberfläche, und die andere Seite ist das Klettband .

2. There sind entsprechendes Klettband B unter der Bettseite und unter dem Bettschwanz, das fest verbunden werden kann. Bitte befestigen Sie den Lichtgurt an der Unterseite des Bettes.)

(1. Un côté de la barre de lumière est la surface lumineuse, et l'autre côté est la bande velcro .

2. Il y a le ruban velcro correspondant B sous le côté du lit et sous la queue du lit, qui peut être fermement collé s'il vous plaît ajuster la ceinture légère au fond du côté du lit.)

Step 20:

P



x4

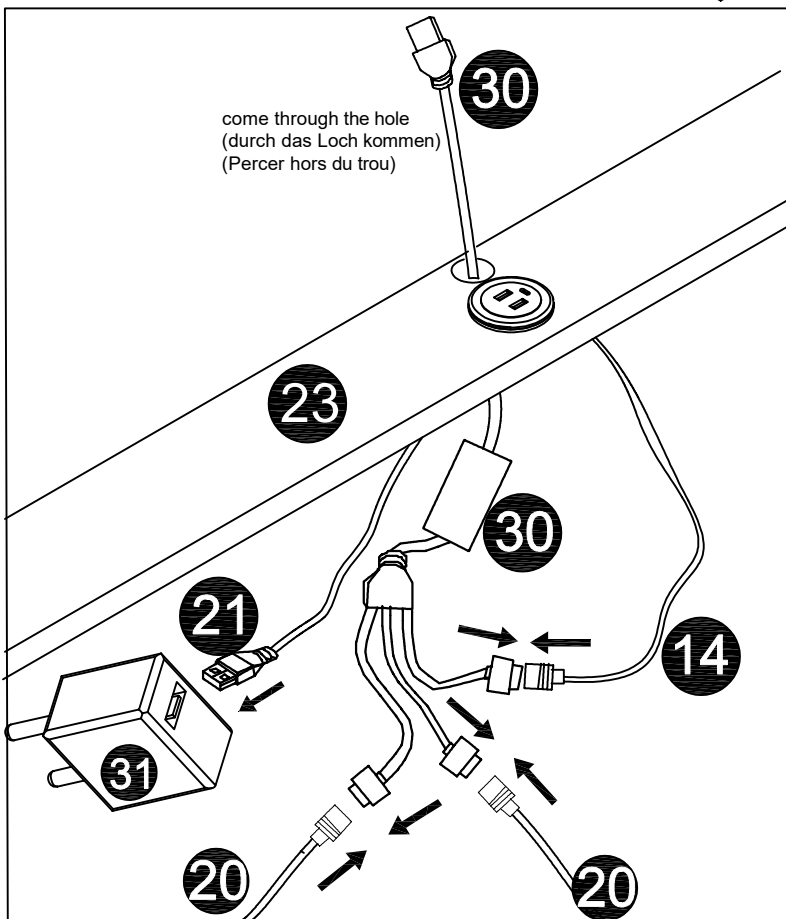
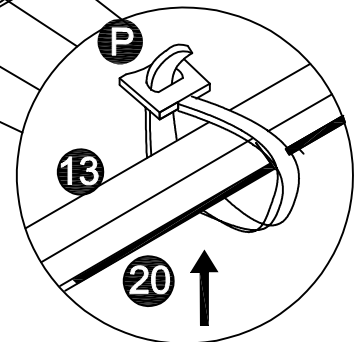
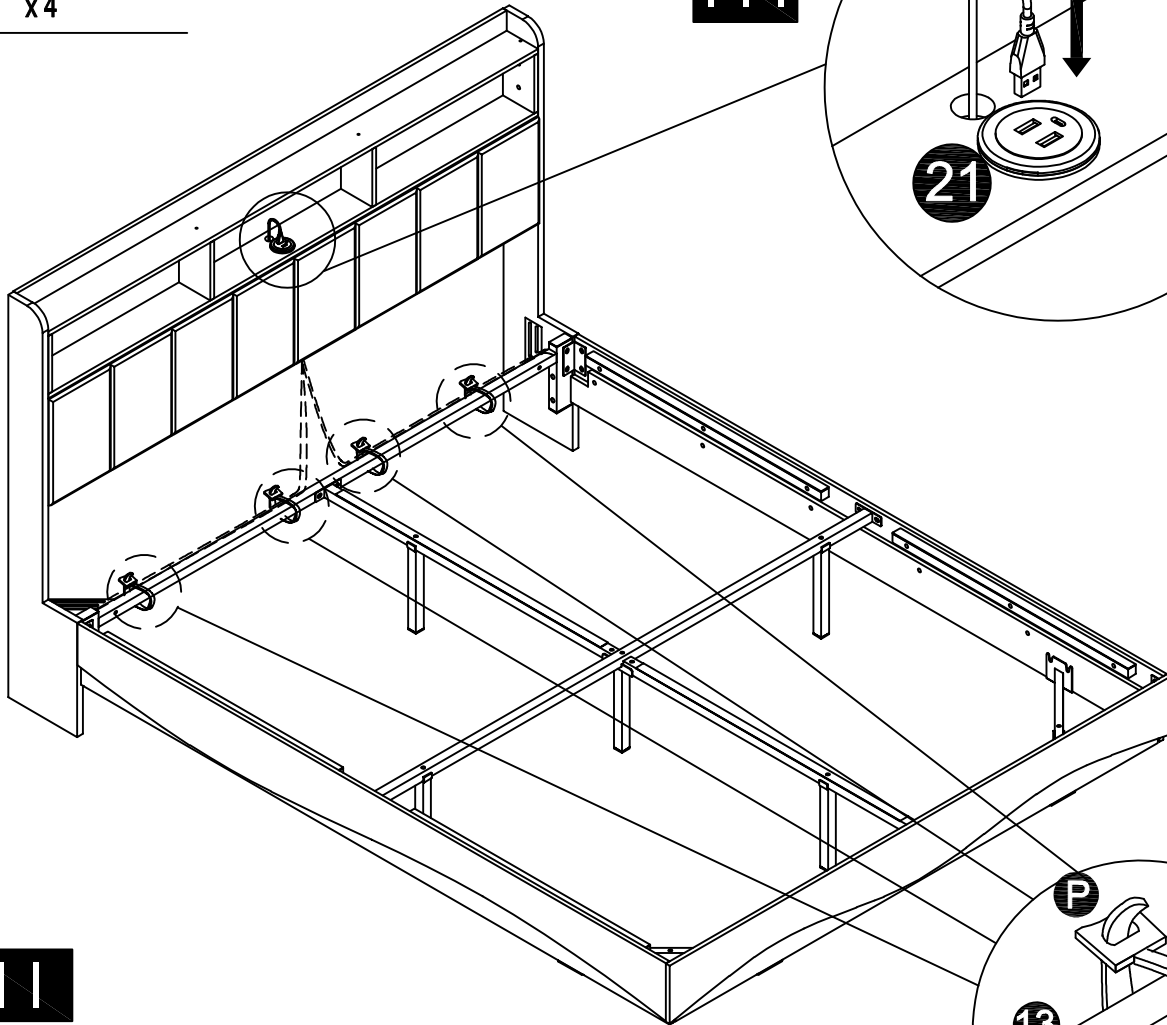
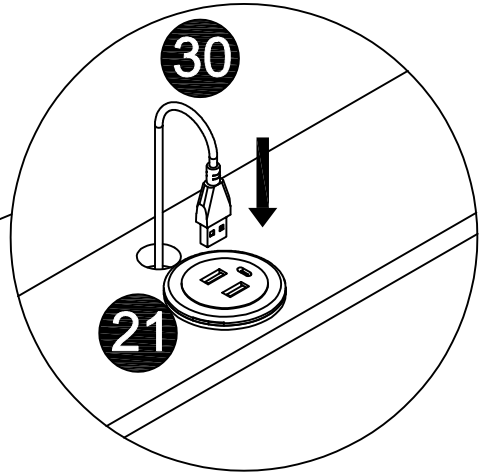

come through the hole
(durch das Loch kommen)
(Percer hors du trou)

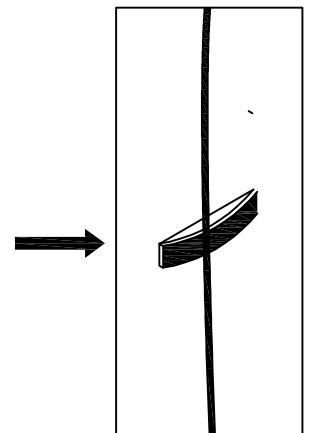
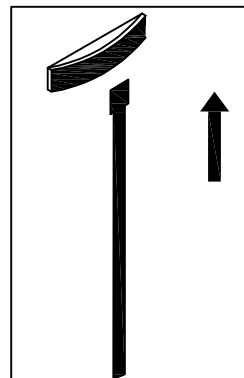

Please string the thread
to the elastic band.
(Bitte string der Faden
zum Gummizug Band.)
(S'il vous plaît string Le fil
Vers l'élastique Bande.)

Step 21:

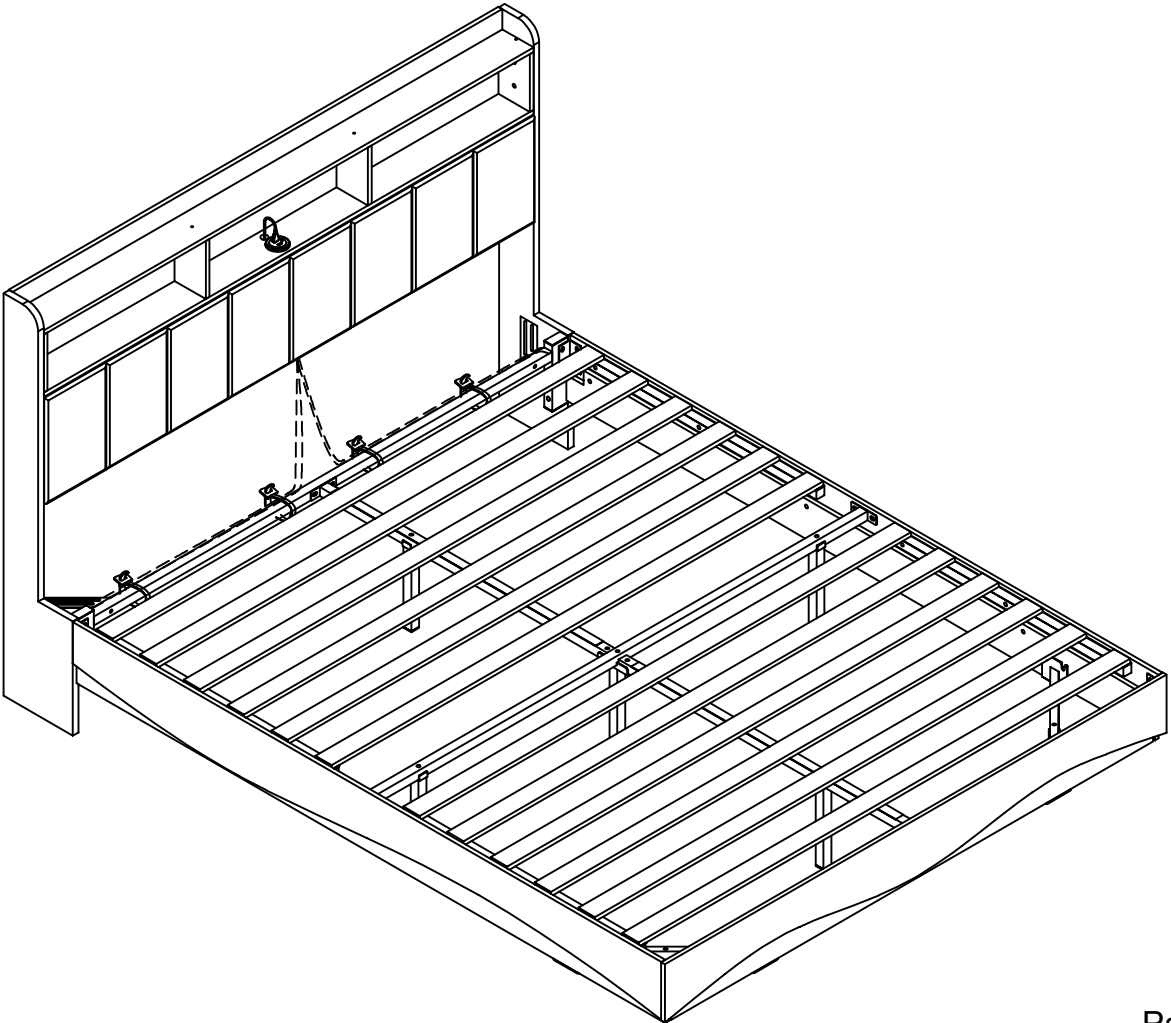
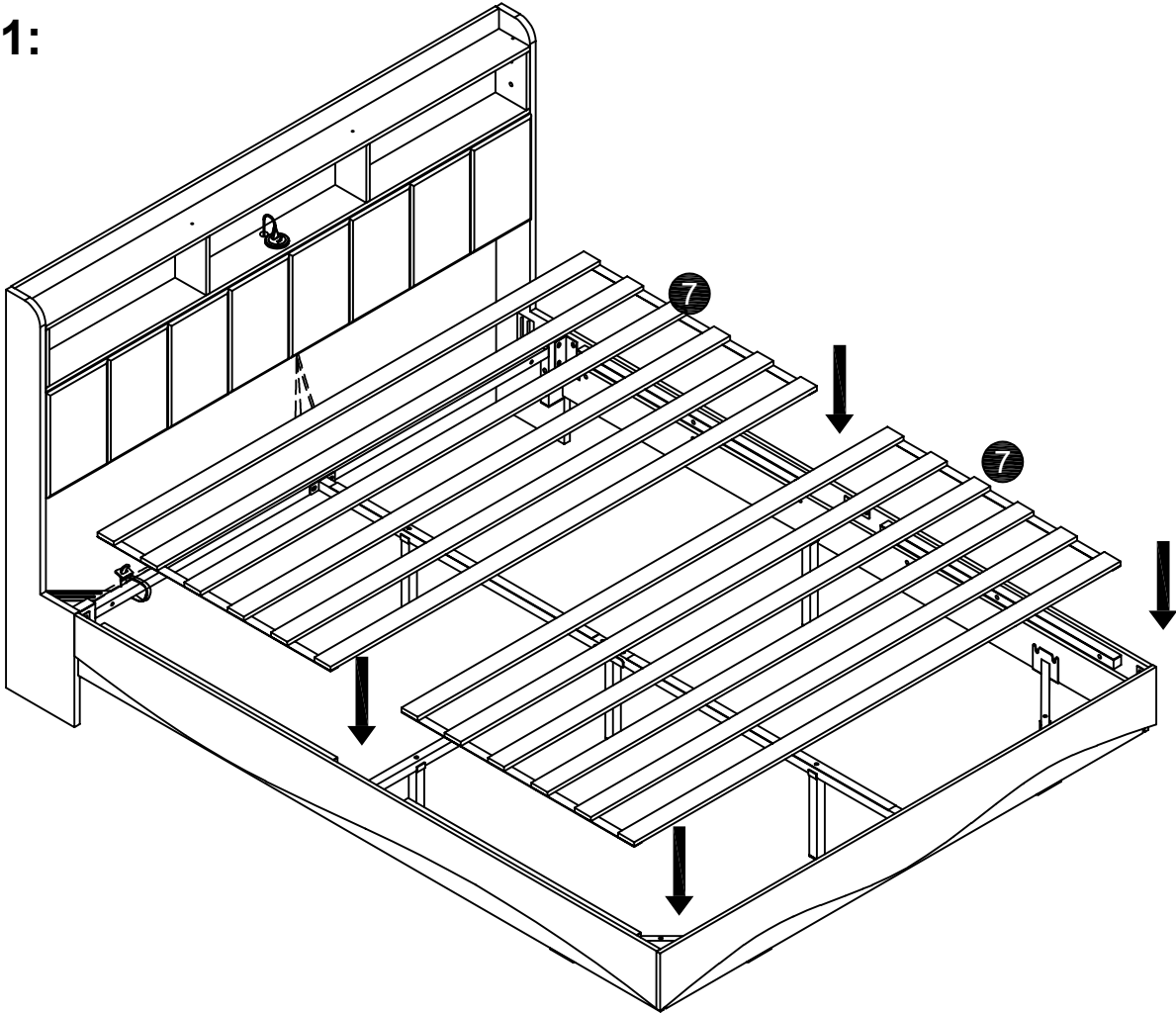

CERTIFICATE



of Conformity Low Voltage Directive 2014/35/EU

Registration No.: AN 50591913 0001

Report No.: CN22ZPS7 002

Holder: XIAMEN INVCY ELECTRONICS
CO., LTD.
1F/3F-5F, BLDG 5,
No.943-5, Tonglong 2nd Rd,
Torch Hi-tech Industrial Zone
(Xiang'an) Xiamen
361000 Fujian
P.R. China

Product: Battery Charger

Identification: Type Designation: IVPxxxx-yyyyz (Invcy)
For detail of the variables xxxx, yyyy, a & z, refer
to TÜV Rheinland license S 50540769 page 0001.
Serial No.: n.a.
Remark: Issued in conjunction with above TÜV Rheinland
license S 50540769 pages 0001-0003.

This certificate of conformity is based on an evaluation of a sample of the above mentioned product. Technical Report and documentation are at the Licence Holder's disposal. This is to certify that the tested sample is in conformity with Annex I of Council Directive 2014/35/EU, referred to as the Low Voltage Directive. This certificate does not imply assessment of the series-production of the product and does not permit the use of a TÜV Rheinland mark of conformity. The holder of the certificate is authorized to use this certificate in connection with the EC declaration of conformity according to Annex IV of the Directive.

Certification Body

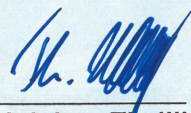

Date 13.07.2023

Dipl.-Ing. Th. Illing

TÜV Rheinland LGA Products GmbH - Tillystraße 2 - 90431 Nürnberg

Page 22 of 24

CE The CE marking may be used if all relevant and effective EC Directives are complied with.





Certificate of Conformity

Certificate Number : QQT202407105EC
Applicant : Shenzhen ShiKeShu Photoelectric Co., Ltd
Address : 1808, Building 11, Tiedong Logistics District, No. 3, Ping'an Avenue, Pinghu Community, Pinghu Street, Longgang District, Shenzhen
Manufacturer : Shenzhen ShiKeShu Photoelectric Co., Ltd
Address : 1808, Building 11, Tiedong Logistics District, No. 3, Ping'an Avenue, Pinghu Community, Pinghu Street, Longgang District, Shenzhen
Brand Name : N/A
Product : 24 Key LED Controller
Model : SKS-DS-03, SKS-DS-04, SKS-DS-05, SKS-BT-10, SKS-JZ-01, SKS-JZ-02, SKS-JZ-14, SKS-JZ-15, SKS-JZ-13, SKS-JZ-17, SKS-JZ-16, SKS-JZ-29, SKS-JZ-09, SKS-JZ-22, SKS-JZ-27, SKS-JZ-25, SKS-JZ-37, SKS-JZ-38, SKS-JZ-39, SKS-PJ-06, SKS-PJ-07

Essential requirement		Applied Standards	Report Number
Art.3.1(a)	Safety	EN IEC 62368-1:2020+A11:2020	QQT202407105-01SR
Art.3.1(a)	Health	EN IEC 62479:2010, EN 50663:2017	QQT202407105-02ER
Art.3.1(b)	EMC	ETSI EN 301 489-1 V2.2.3 (2019-11) ETSI EN 301 489-3 V2.3.2 (2023-01) EN 55032:2015+A11:2020+A1:2020 EN 55035:2017+A11:2020	QQT202407105-03ER
Art.3.2	Radio	ETSI EN 300 220-1 V3.1.1 (2017-02) ETSI EN 300 220-2 V3.2.1 (2018-06)	QQT202407105-04ER

The EUT described above has been tested by us with the listed standards and found in compliance with the council Radio Equipment Directive (RED) 2014/53/EU. It is possible to use CE marking to demonstrate the compliance with this RE Directive.

The certificate applies to the tested sample above mentioned only and shall not imply an assessment of the whole production. It is only valid in connection with the test report number as above listed.



Shenzhen Qiqing Technology Co., Ltd.
 Room.802, Zhongcheng Sci-tech Building, No.543, Jinbi Road, Biling Street,
 Pingshan District, Shenzhen, Guangdong, China
 WEB: www.qq-lab.com Email: Serviec@qq-lab.com Tel: 0755-28266974

Shenzhen ZKT Technology Co., Ltd.
 1/F, No. 101, Building B, No. 6, Tangwei Community Industrial Avenue,
 Fuhai Street, Bao'an District, Shenzhen, China



Certificate of Compliance

Certificate Number: ZKT-2403202772C

- Certificate's Holder** : Shenzhen Pinchengxin Technology Co., Ltd
 3rd Floor, 8th Building Yuanling Industrial Zone, No. 39
 Yuanlingcun Road, Shiyan Street, Bao'an District,
 Shenzhen
- Manufacturer** : Shenzhen Pinchengxin Technology Co., Ltd
 3rd Floor, 8th Building Yuanling Industrial Zone, No. 39
 Yuanlingcun Road, Shiyan Street, Bao'an District,
 Shenzhen
- Trade Mark** : N/A
- Product** : 5050 RGB LED Strip Lights with Bluetooth App Controller
 and 2.4G Remote
- Model(s)** : 5050 RGB LED Strip Lights
- Test Standard** : Art.3.1(a) Safety EN IEC 62368-1:2020+A11:2020
 Art.3.1(a) Health EN IEC 62311:2020
 EN 50665:2017
 Art.3.1(b) EMC ETSI EN 301 489-1 V2.2.3 (2019-11)
 ETSI EN 301 489-17 V3.2.4 (2020-09)
 Art.3.2 Radio ETSI EN 300 328 V2.2.2 (2019-07)

This Attestation of Compliance is issued on a voluntary basis for electrical equipment below the voltage limits of Radio Equipment Directive (RED) 2014/53/EU. The essential requirements are fulfilled accordingly based on the technical specifications applicable at the time of issuance.



This Certificate of Conformity is based on single evaluation of the submitted sample(s) of the above mentioned product. It does not imply an assessment of the whole product and relevant Directives to be observed.