

- (D)** Montageanleitung
- (NL)** Handleiding voor de montage
- (HU)** Szerelési útmutató
- (GB)** Assembly instructions
- (PL)** Instrukcja montażu

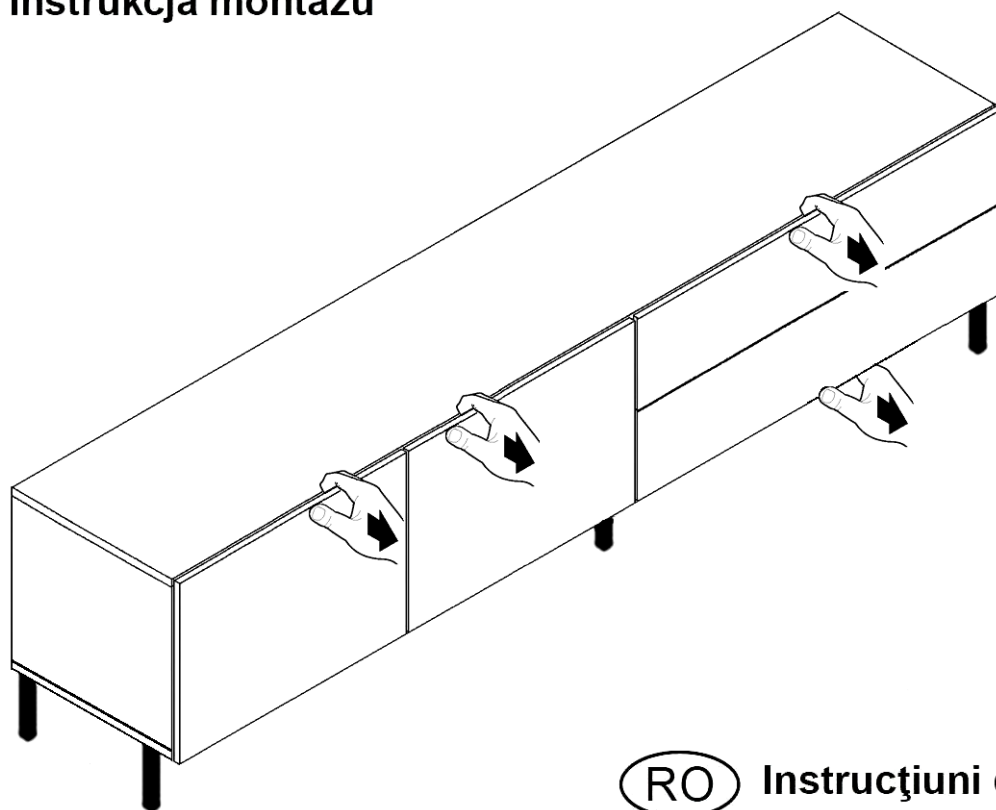

- (RO)** Instrucțiuni de montaj
- (FR)** Notice de montage
- (CZ)** Montážní návod
- (TR)** Montaj talimatı
- (IT)** Istruzioni di montaggio
- (SK)** Návod na montáž
- (RU)** Инструкция по монтажу

**Service • Assistenza • Dienstverlening • Serwis  
Servis • Szerviz • Сервисная служба**

Name • Nom • Nome • Naam •  
Nazwa • Jméno • Názov • Név •  
Denúmie • Ísim • Название

Nr. • No. • N° • Номер • Č • Sz

Тур • Type • Тір • Típus • Тіро •  
Тип

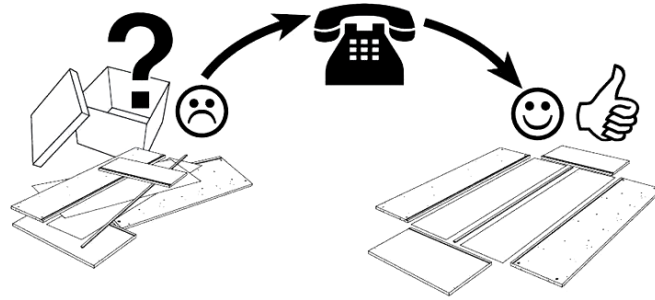
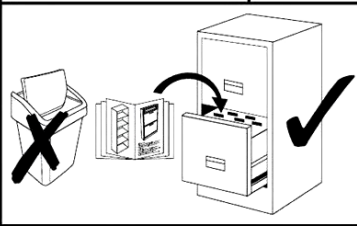

**1** ≠ **3a**

<b>1</b>	1x	ca. 1520 x 330 mm
<b>2</b>	1x	ca. 1501 x 326 mm
<b>3a</b>	1x	ca. 1520 x 330 mm
<b>4a</b>	1x	ca. 314 x 330 mm
<b>5a</b>	1x	ca. 314 x 315 mm
<b>6a</b>	1x	ca. 314 x 315 mm
<b>7a</b>	1x	ca. 314 x 330 mm

<b>9</b>	2x	ca. 348 x 377 mm
<b>10</b>	2x	ca. 757 x 172 mm
<b>11-L</b>	2x	ca. 310 x 88 mm
<b>11-M</b>	2x	ca. 695 x 88 mm
<b>11-R</b>	2x	ca. 310 x 88 mm
<b>12</b>	2x	ca. 707 x 307 mm

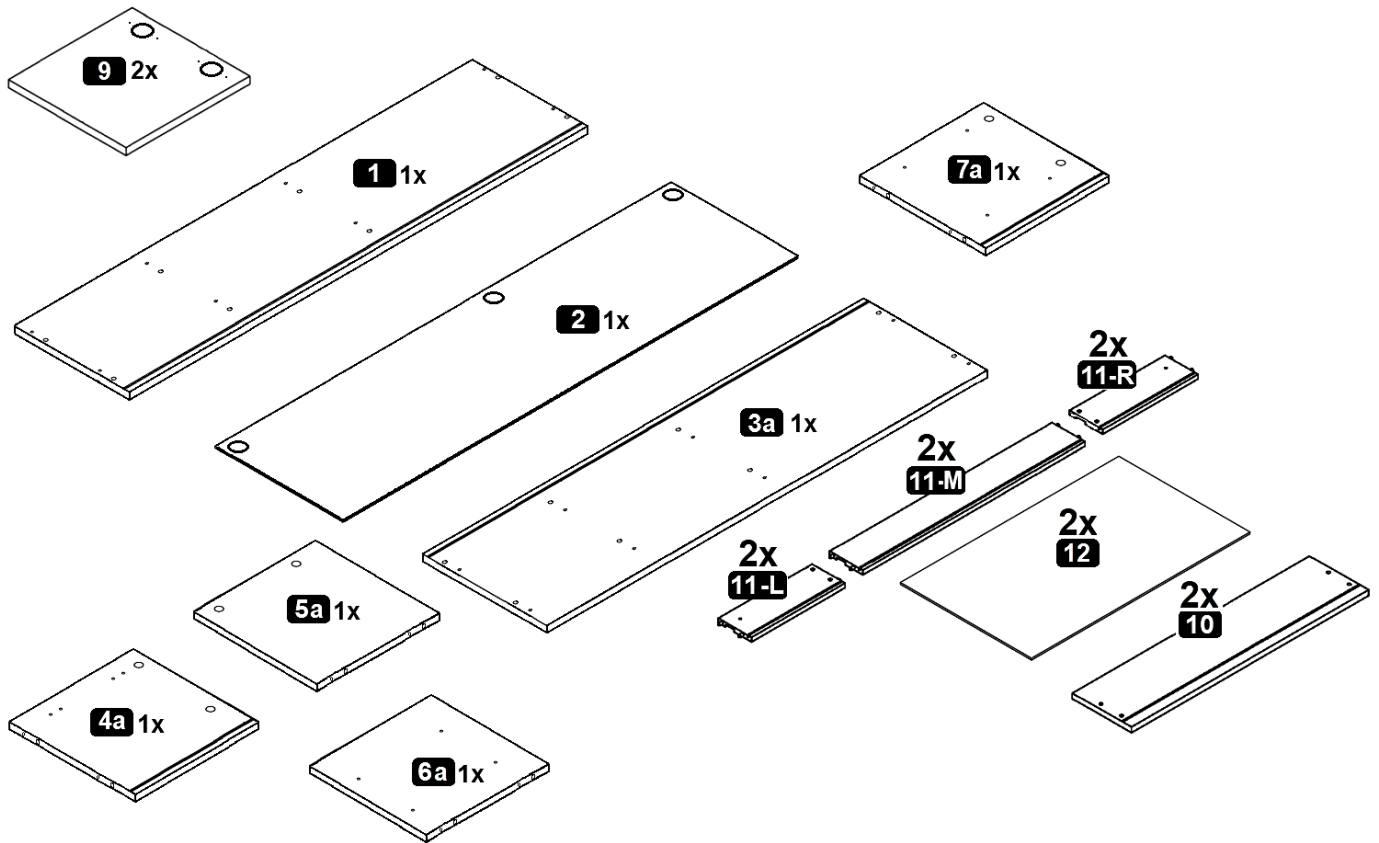

<b>A</b> 8,0 x 30 mm <b>16x</b>	<b>B</b> <b>8x</b>	<b>C</b> <b>8x</b>	<b>F</b> <b>1x</b>
<b>H</b> 17x310 mm <b>4x</b>	<b>I</b> 6,3 x 13 mm <b>8x</b>	<b>J</b> M4,0 x 9 mm <b>4x</b>	<b>L</b> h=2 <b>2x</b>
<b>O</b> 2,7 x 20 mm <b>4x</b>	<b>P</b> h=4 <b>2x</b>	<b>M</b> Ø35 Kr.0 <b>2x</b>	<b>N</b> Ø35 Kr.15 <b>2x</b>
<b>X</b> M4x16 mm <b>10x</b>	<b>Y</b> 4,0x17 mm <b>15x</b>	<b>Z</b> <b>5x</b>	<b>U</b> 5,0 x 50 mm <b>8x</b>

MA1X



**1**

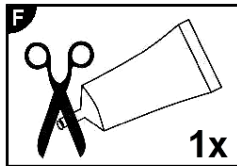
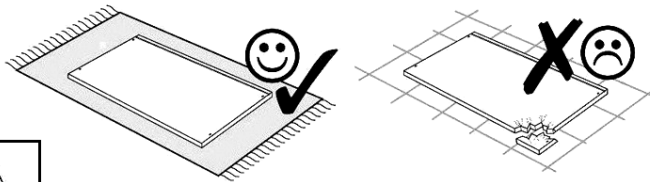

D	Leim
GB	Glue
FR	Colle
IT	Colla
NL	Lijm
PL	Klej
CZ	Lepidlo
SK	Glej
HU	Enyv
RO	Adeziv
TR	Tutkal
RU	Клей

**2x**

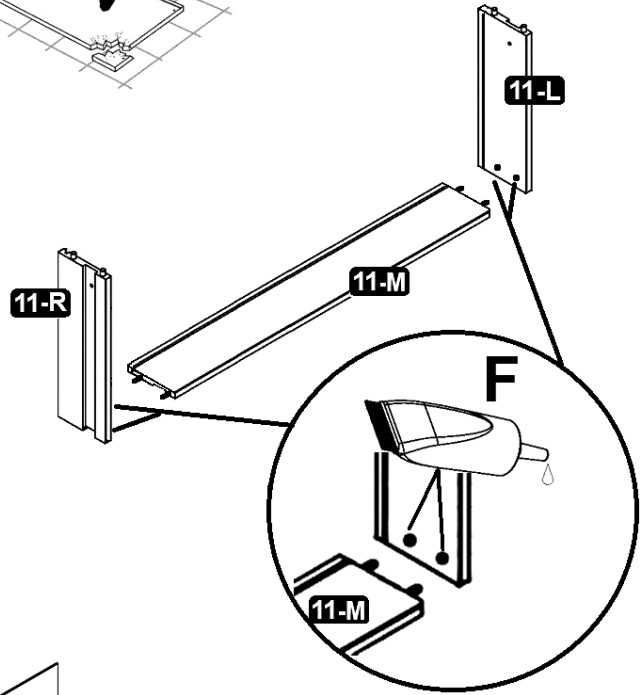

**2x**

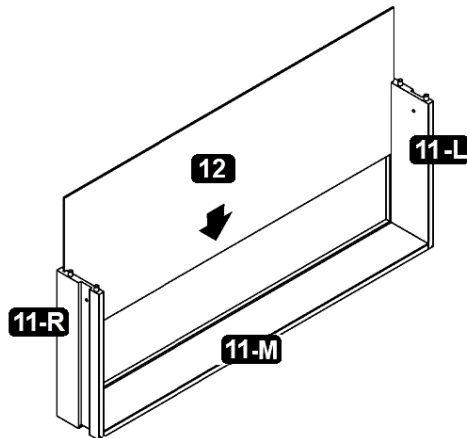

**2x**

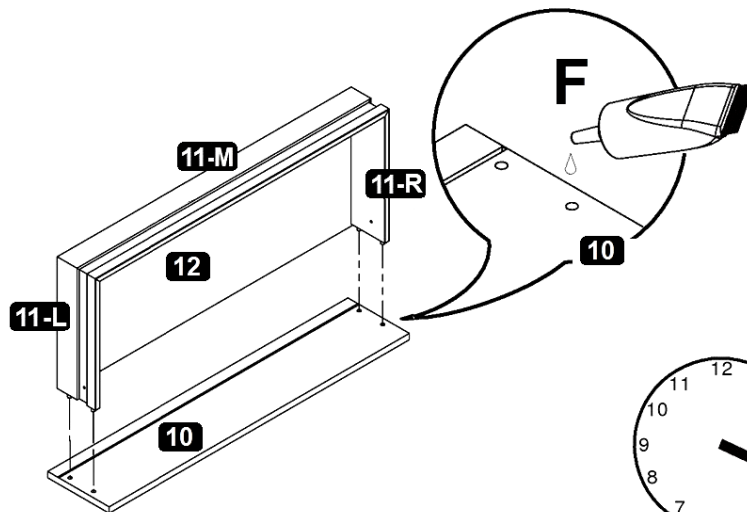

**20min**

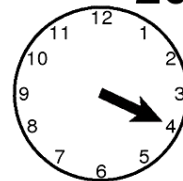



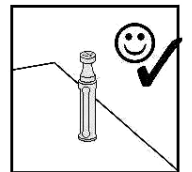
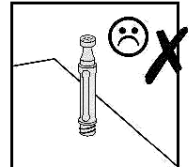
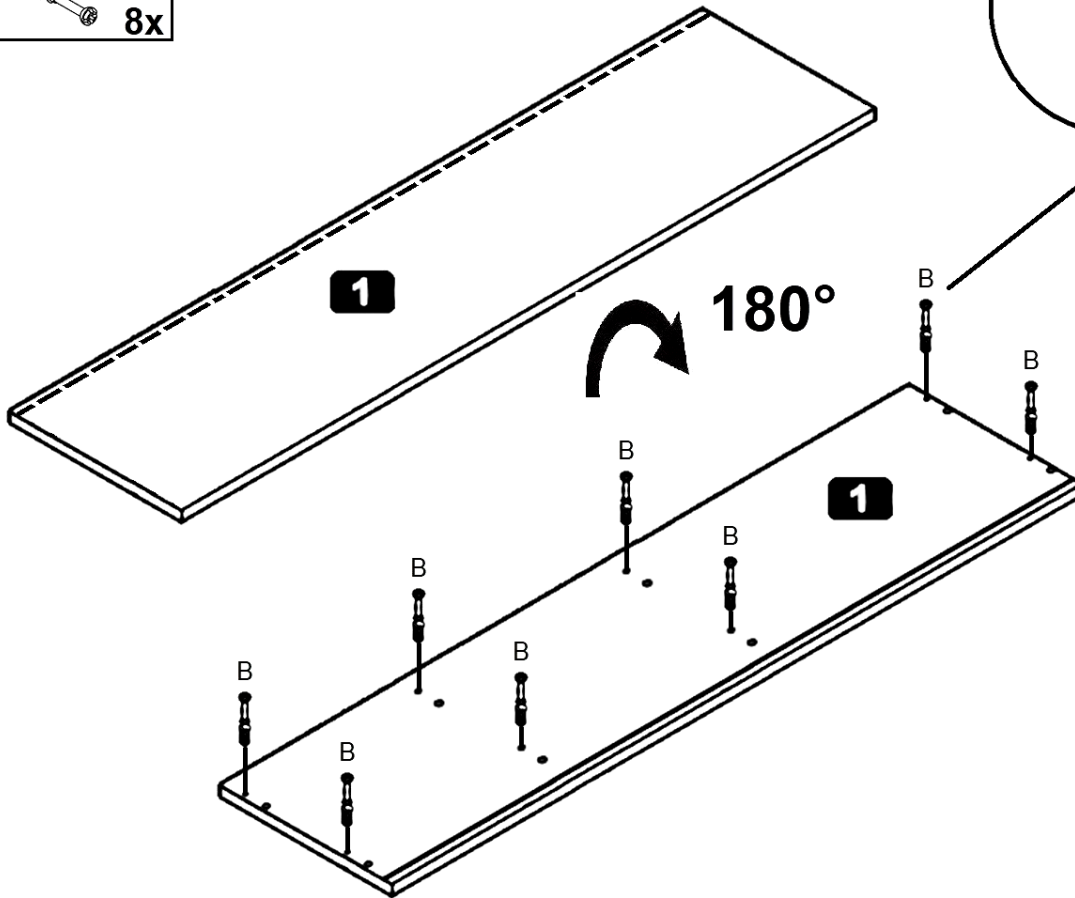
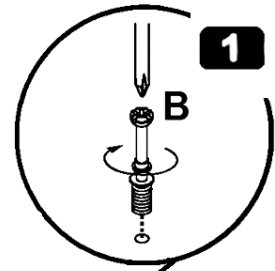
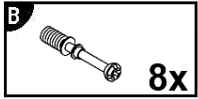
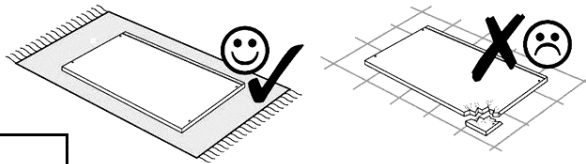

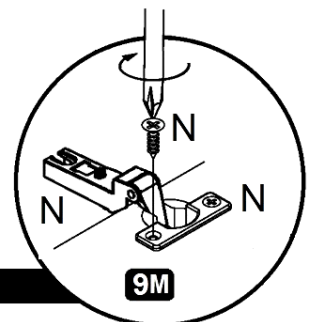
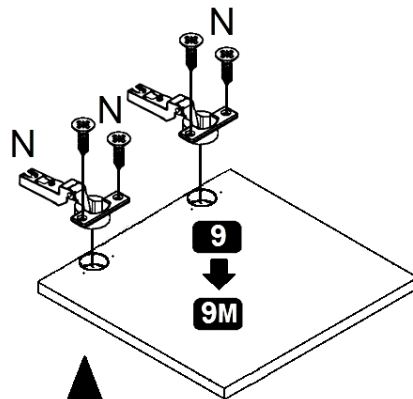
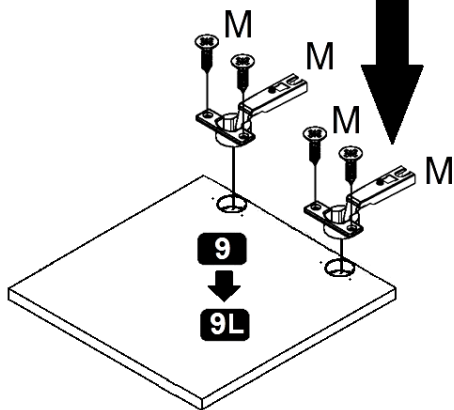
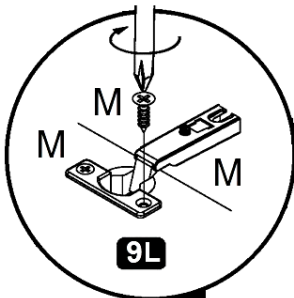
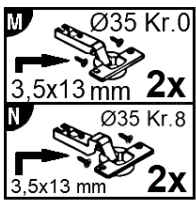

**2**



**3**

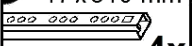

# 4

<b>A</b> 8,0 x 30 mm  <b>16x</b>	<b>C</b>  <b>8x</b>	<b>H</b> 17 x 310 mm  <b>4x</b>	<b>I</b> 6,3 x 13 mm  <b>8x</b>
<b>L</b> h=2  <b>2x</b>	<b>P</b> h=4  <b>2x</b>		

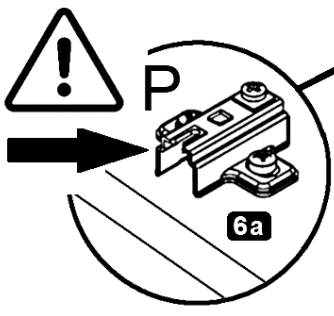
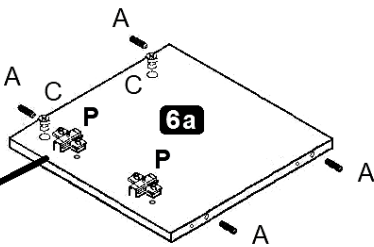
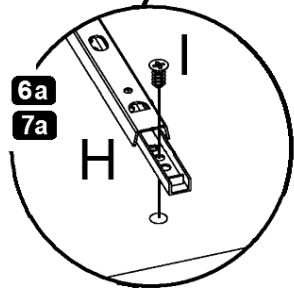
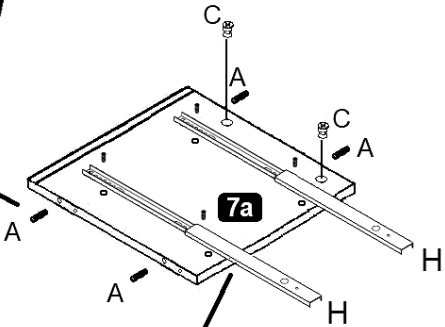
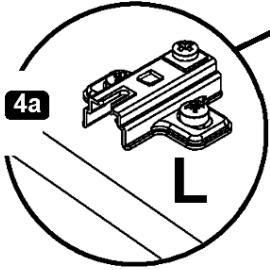
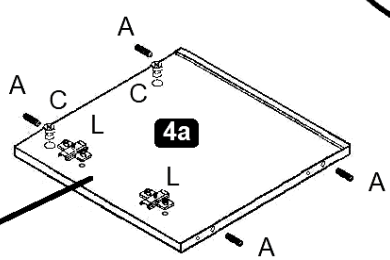
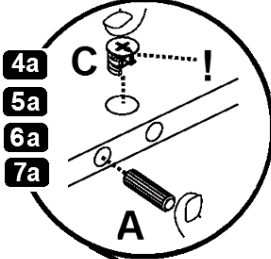

**180°** 

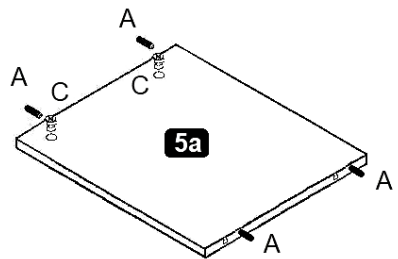
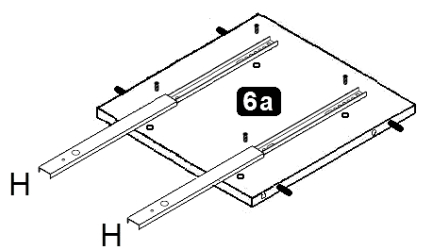

# 5

U 5,0 x 50 mm  
8x

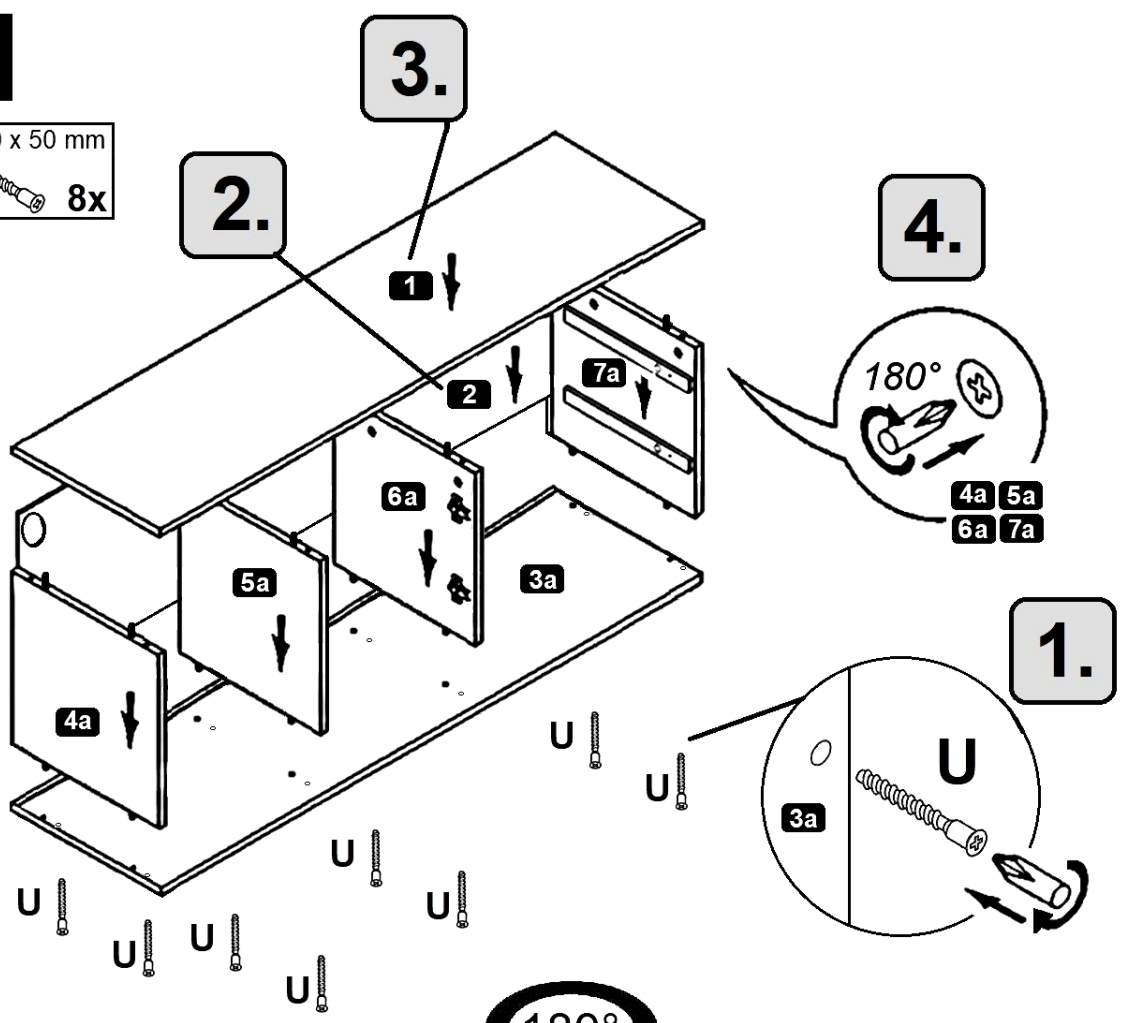

# 6

o 2,7 x 20 mm  
4x

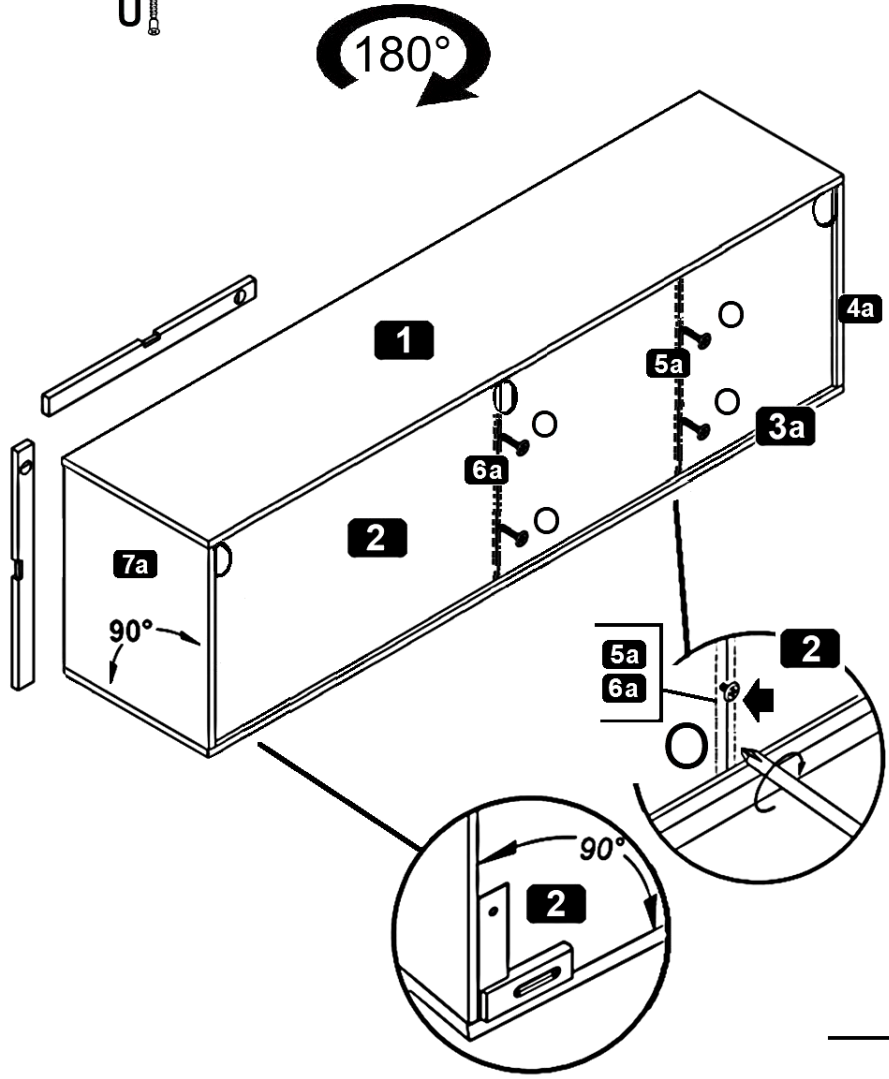

# 7

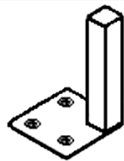

- |                                       |                                      |
|---------------------------------------|--------------------------------------|
| (D) Montage der Metallfüße            | (CZ) Montáž kovových nožiček         |
| (GB) Assembly of the metal feet       | (RO) Asamblarea picioarelor metalice |
| (FR) Assemblage des pieds métalliques | (HU) A fém lábak összeszerelése      |
| (IT) Montaggio dei piedini in metallo | (SK) Montáž kovových nožičiek        |
| (NL) Montage van de metalen voetjes   | (TR) Metal ayakların montajı         |
| (PL) Montaż metalowych nóg            | (RU) Asamblarea picioarelor metalice |

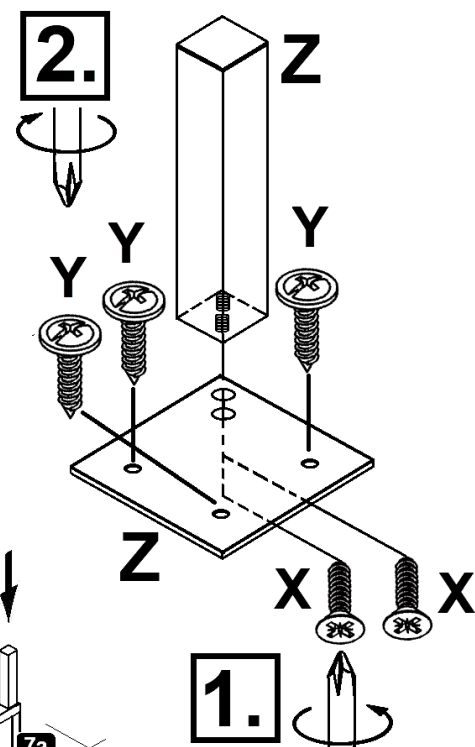
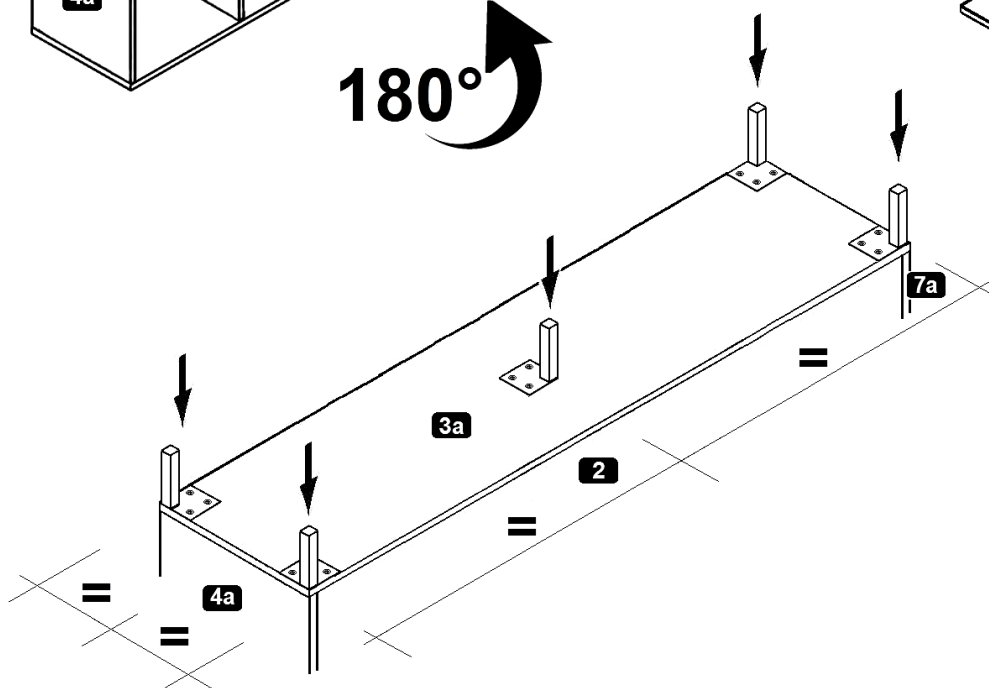
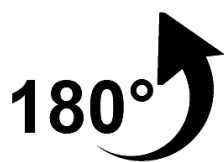
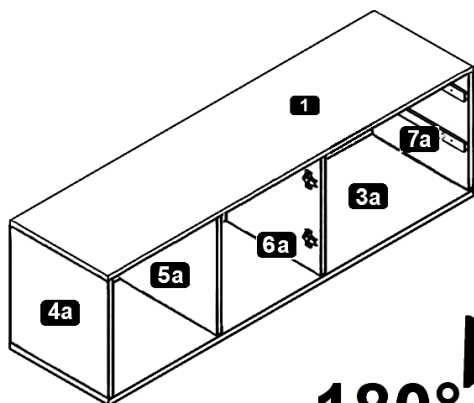
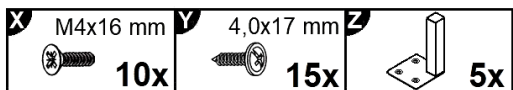

**8**

**J** M4,0 x 9 mm  
 **4x**

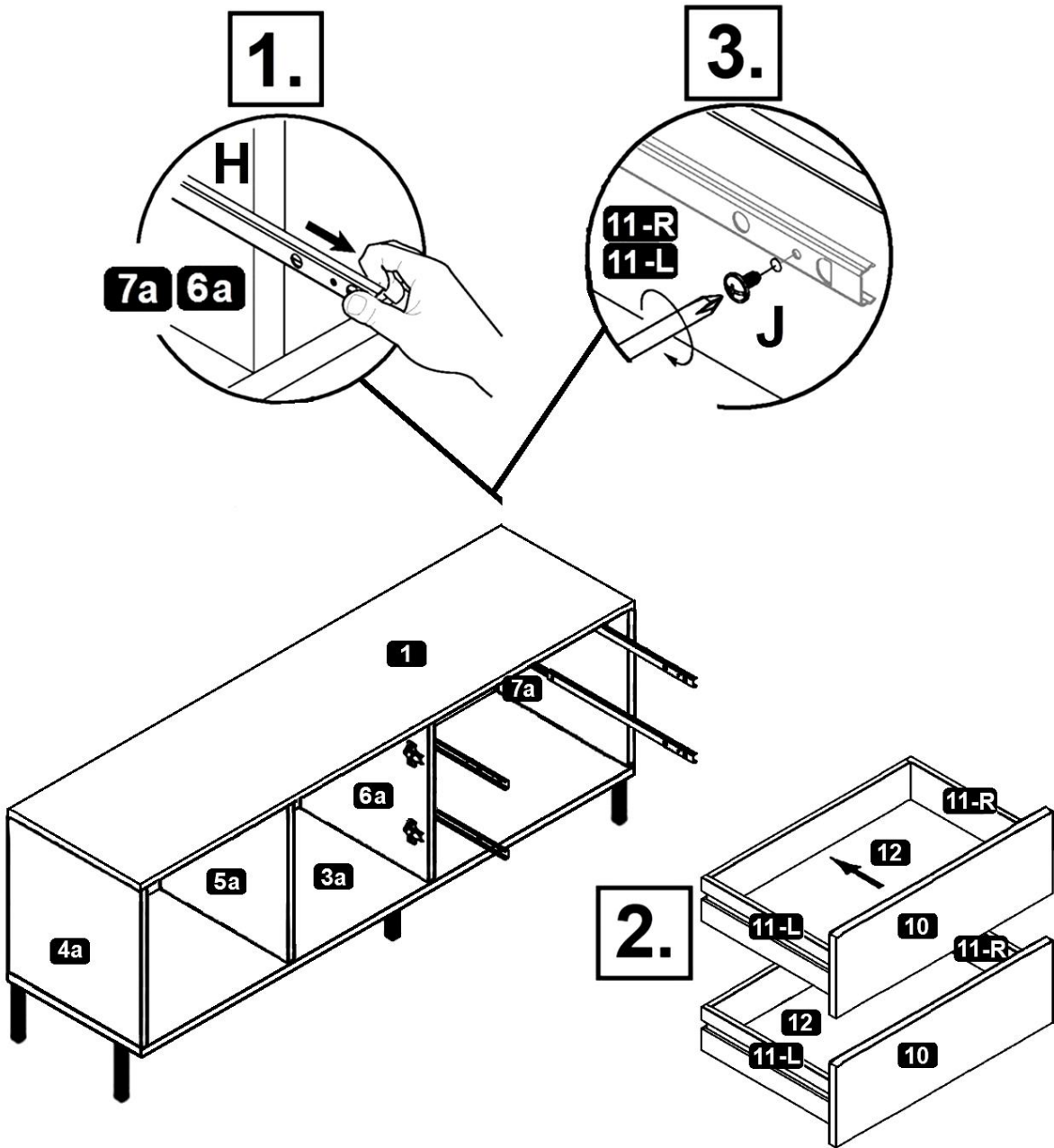



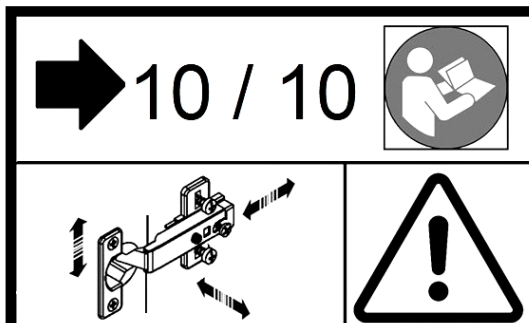
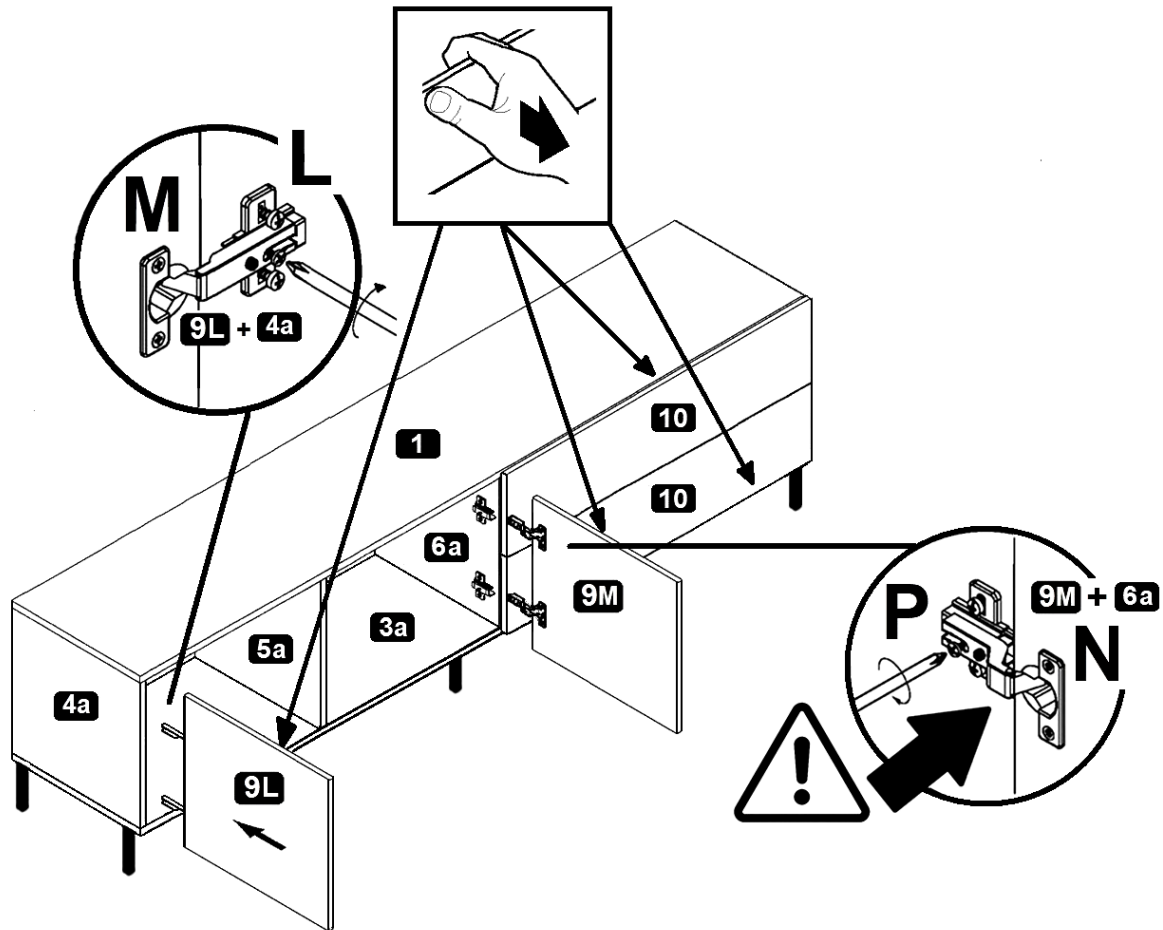

- (D) Türen einstellen  
(Scharniere justieren)
- (GB) Adjusting the doors  
(adjusting the hinges)
- (FR) Régler les portes  
(ajuster les charnières)
- (IT) Sistemare le porte  
(regolare le cerniere)
- (NL) Deuren instellen  
(scharnieren afstellen)
- (PL) Nastawić drzwi  
(wyregulować zawiasy)

- (CZ) Vyrovnajte dvířka  
(seřid'te závěsy)
- (RO) Nastavenie dverí  
(nastavenie závesov)
- (HU) Állítsa be az ajtókat  
(állítsa be a zsanérokot)
- (SK) Reglare uši  
(ajustare balamale)
- (TR) Kapıların ayarlanması  
(menteşelerin seviye ayarı)
- (RU) Регулировка дверей  
(регулировка шарнира)

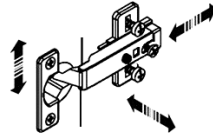

(D) Türen einstellen  
(Scharniere justieren)

(GB) Adjusting the doors  
(adjusting the hinges)

(FR) Régler les portes  
(ajuster les charnières)

(IT) Sistemare le porte  
(regolare le cerniere)

(NL) Deuren instellen  
(scharnieren afstellen)

(PL) Nastawić drzwi  
(wyregulować zawiasy)

(CZ) Vyrovnajte dvířka  
(seřid'te závěsy)

(RO) Nastavenie dverí  
(nastavenie závesov)

(HU) Állítsa be az ajtókat  
(állítsa be a zsanérokot)

(SK) Reglare uši  
(ajustare balamale)

(TR) Kapıların ayarlanması  
(menteşelerin seviye ayarı)

(RU) Регулировка дверей  
(регулировка шарнира)

