

ASSEMBLY INSTRUCTION

WF301945/WF301946
WF301947/WF301948

TIPS

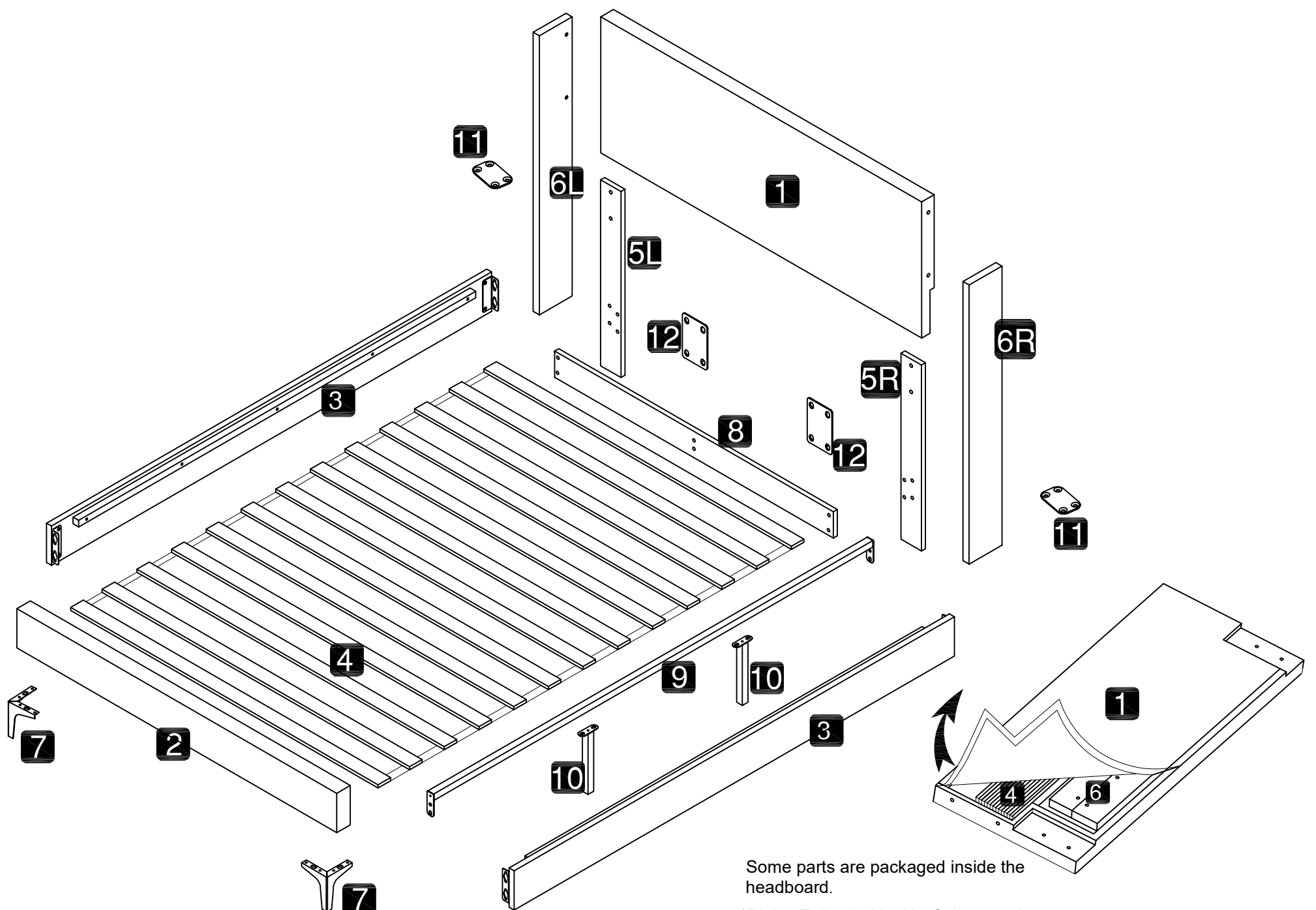

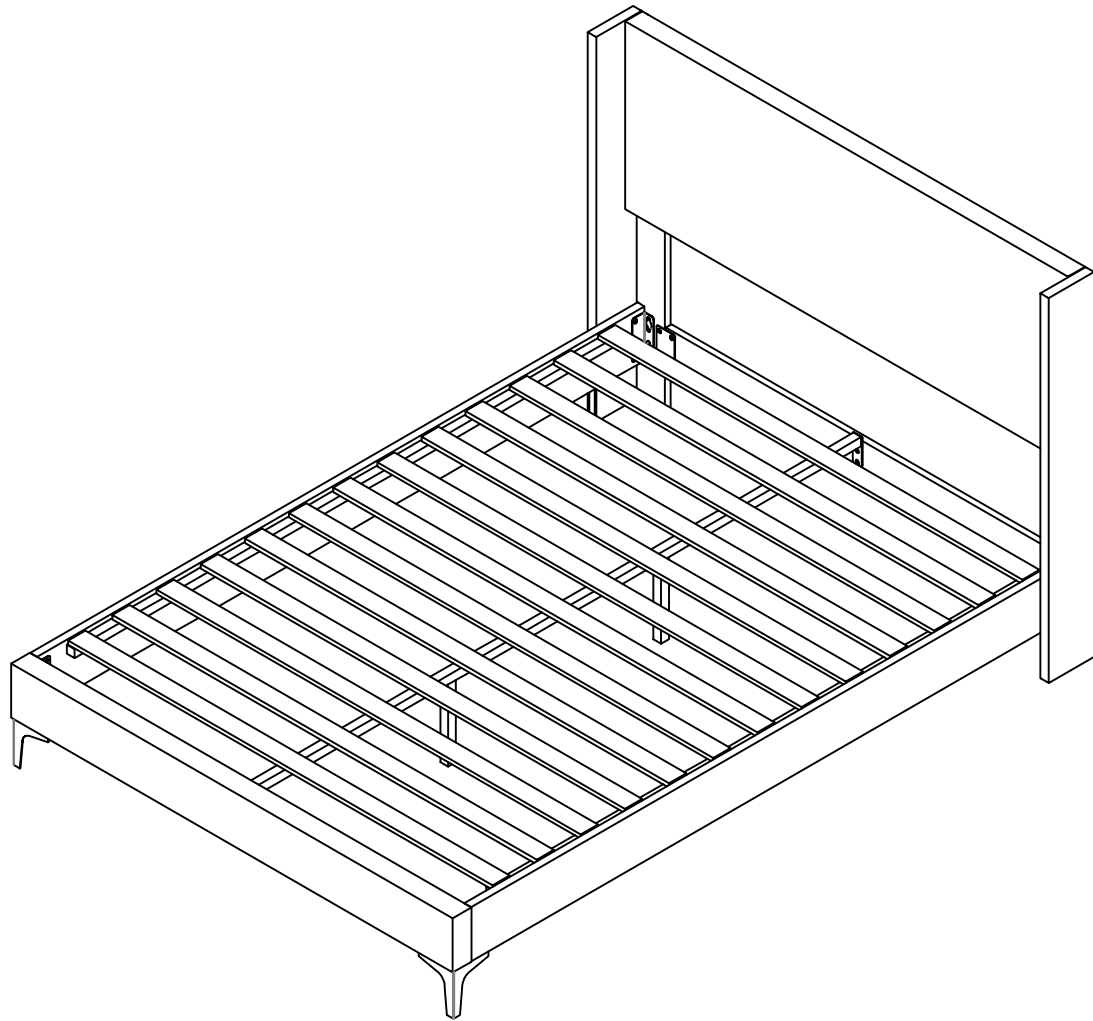



1. Please read the instructions fully before assembly. These instructions include important information which could ensure correct assembly. We have been working on providing high quality products for you. However, in the rare instance that your product is defective, missing parts or there are some issues, please don't hesitate to contact our customer service to submit parts requirements, assembly suggestion, or warranty claims, and we will give the best solution as soon as possible. If necessary, we need you to provide some more clear pictures of the issue.
2. Insert the screws in holes and tighten the screws, but not too tight, 70%~80% is ok, finally tighten all the screws. If some issues happened that some screws can not target to the hole or some parts are difficult to install, please adjust the tightness of the screws.
3. 2 people are recommended to finish



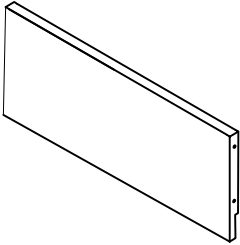
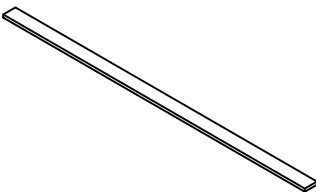

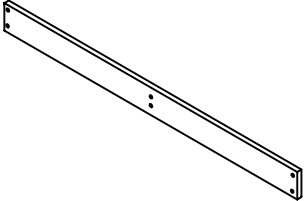
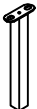
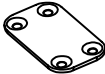
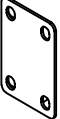

Some parts are packaged inside the headboard.

(Einige Teile sind im Kopfteil verpackt.)

Part List WF301945AAG/WF301947AAS

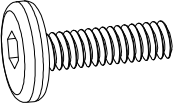
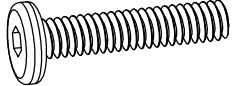
<p>1</p>  <p>Headboard x 1</p>	<p>4</p>  <p>Slats x 13</p>	<p>5L</p>  <p>Head board leg -(LH) x 1</p>	<p>5R</p>  <p>Head board leg-(RH) x 1</p>
<p>6L</p>  <p>Bedside wing -(LH)x 1</p>	<p>6R</p>  <p>Bedside wing -(RH)x 1</p>	<p>7</p>  <p>Leg x 2</p>	<p>8</p>  <p>Head board leg Connecting plate x 1</p>
<p>10</p>  <p>Connected support leg x 2</p>	<p>11</p>  <p>belaying cleat x 2</p>	<p>12</p>  <p>Connecting iron sheet x 2</p>	

Hardware List WF301945AAG/WF301947AAS

<p>A</p>  <p>Bolts(M8x20mm) x22</p>	<p>B</p>  <p>Bolts(M8x40mm) x8</p>	<p>C</p>  <p>Screw(5.0x25mm) x4</p>	<p>D</p>  <p>Screw(4.0x15mm) x8</p>	<p>E</p>  <p>Flat Washer x10</p>
<p>F</p>  <p>Allen Key x1</p>				

Part List WF301946AAG/WF301948AAS

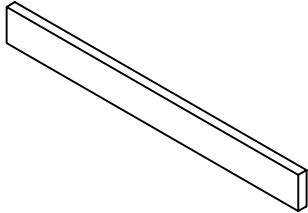
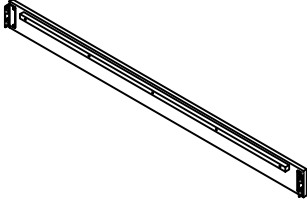
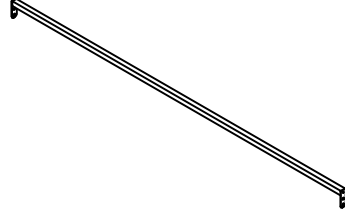
<p>2</p>  <p>Footboard x 1</p>	<p>3</p>  <p>Side Rails x 2</p>	<p>9</p>  <p>Central Support Rail x 1</p>	
--------------------------------------------------------------------------------------------------------------------------	---------------------------------------------------------------------------------------------------------------------------	---------------------------------------------------------------------------------------------------------------------------------------	--

Step 1

B  x4

E  x4

F  x1

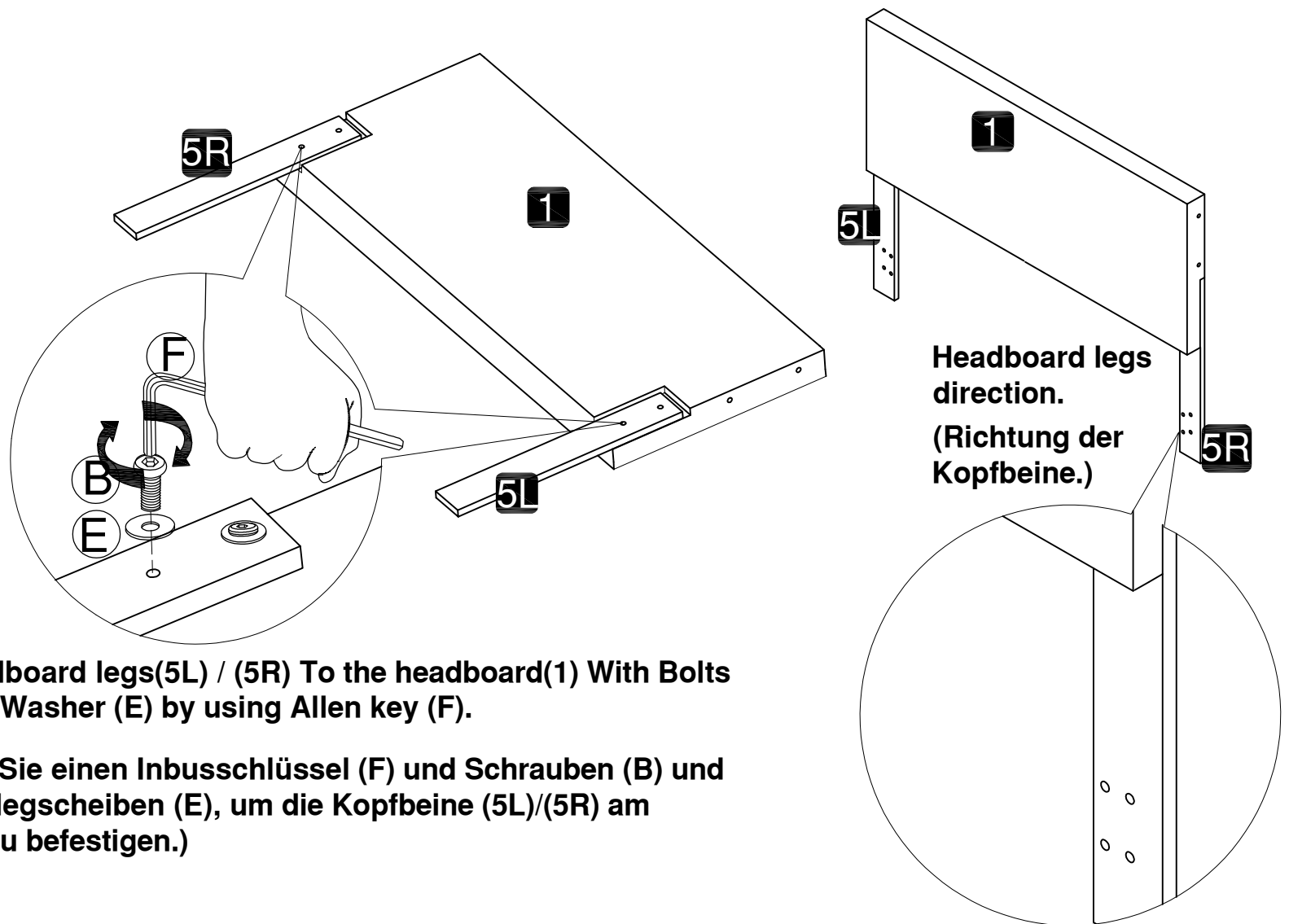

Fix the Headboard legs(5L) / (5R) To the headboard(1) With Bolts (B) and Flat Washer (E) by using Allen key (F).

(Verwenden Sie einen Inbusschlüssel (F) und Schrauben (B) und flache Unterlegscheiben (E), um die Kopfbeine (5L)/(5R) am Kopfteil (1) zu befestigen.)

Step 2

A  x4

F  x1

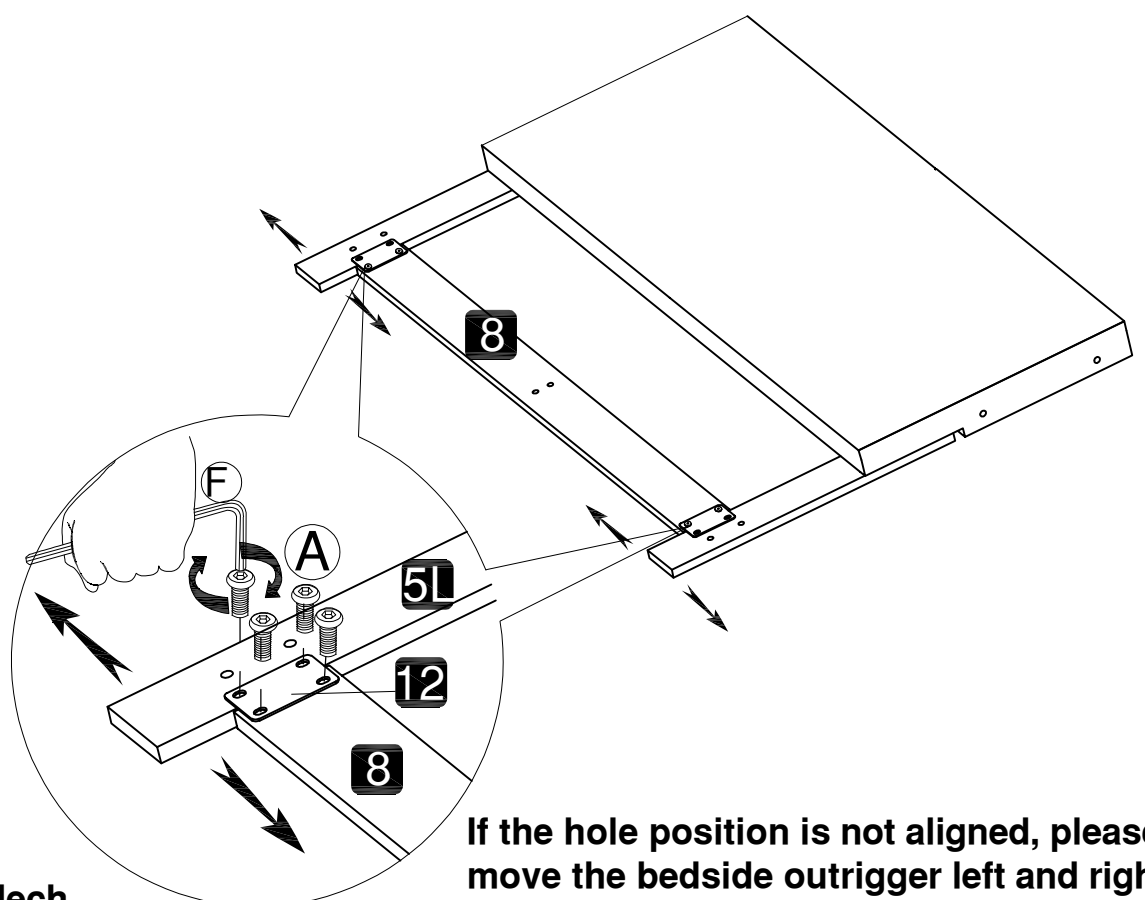

Fix the connecting iron sheet (12) to the head plate leg (5L)/(5R) and leg connecting plate (8) with the hexagon wrench (F) bolt (A).

(Befestigen Sie das Verbindungsblech (12) am Kopfplattenbein (5L)/(5R) und Beinverbindungsplatte (8) mit dem Sechskantschlüssel (F) Bolzen (A).)

If the hole position is not aligned, please move the bedside outrigger left and right until the hole position is aligned.

(Wenn die Lochposition nicht ausgerichtet ist, bewegen Sie bitte die Bettstütze nach links und rechts, bis die Lochposition ausgerichtet ist.)

Step 3

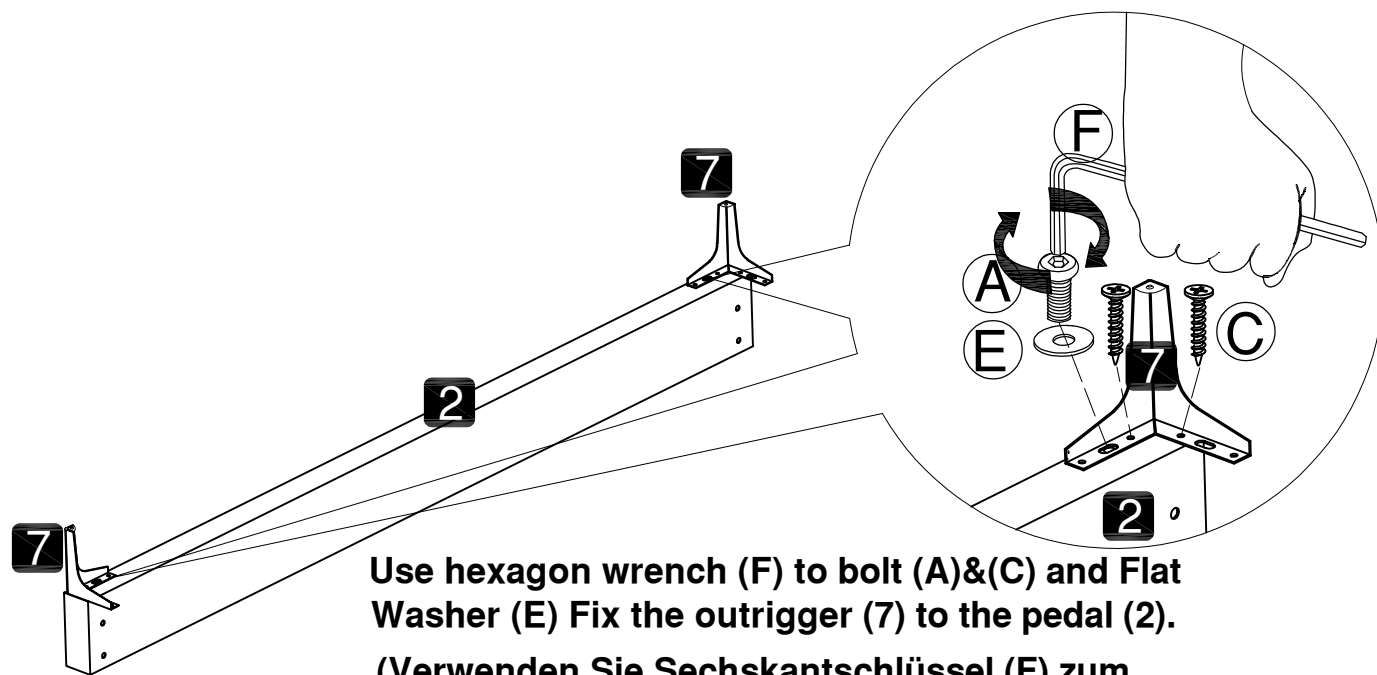
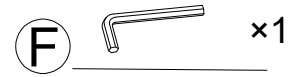
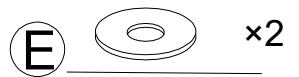
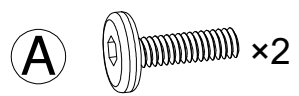

Use hexagon wrench (F) to bolt (A)&(C) and Flat Washer (E) Fix the outrigger (7) to the pedal (2).

(Verwenden Sie Sechskantschlüssel (F) zum Schrauben (A)&(C) und Flachscheibe(E) Befestigen Sie die Stütze (7) am Pedal (2).)

Step 4

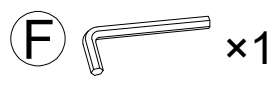
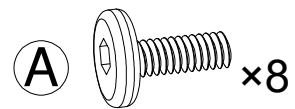

Fix the Connected support leg (10) to the Central Support Rail (9) with the wrench (F) and bolt (A).

(Befestigen Sie das angeschlossene Stützbein (10) mit dem Schlüssel (F) und Bolzen (A) an der zentralen Stützschiene (9).)

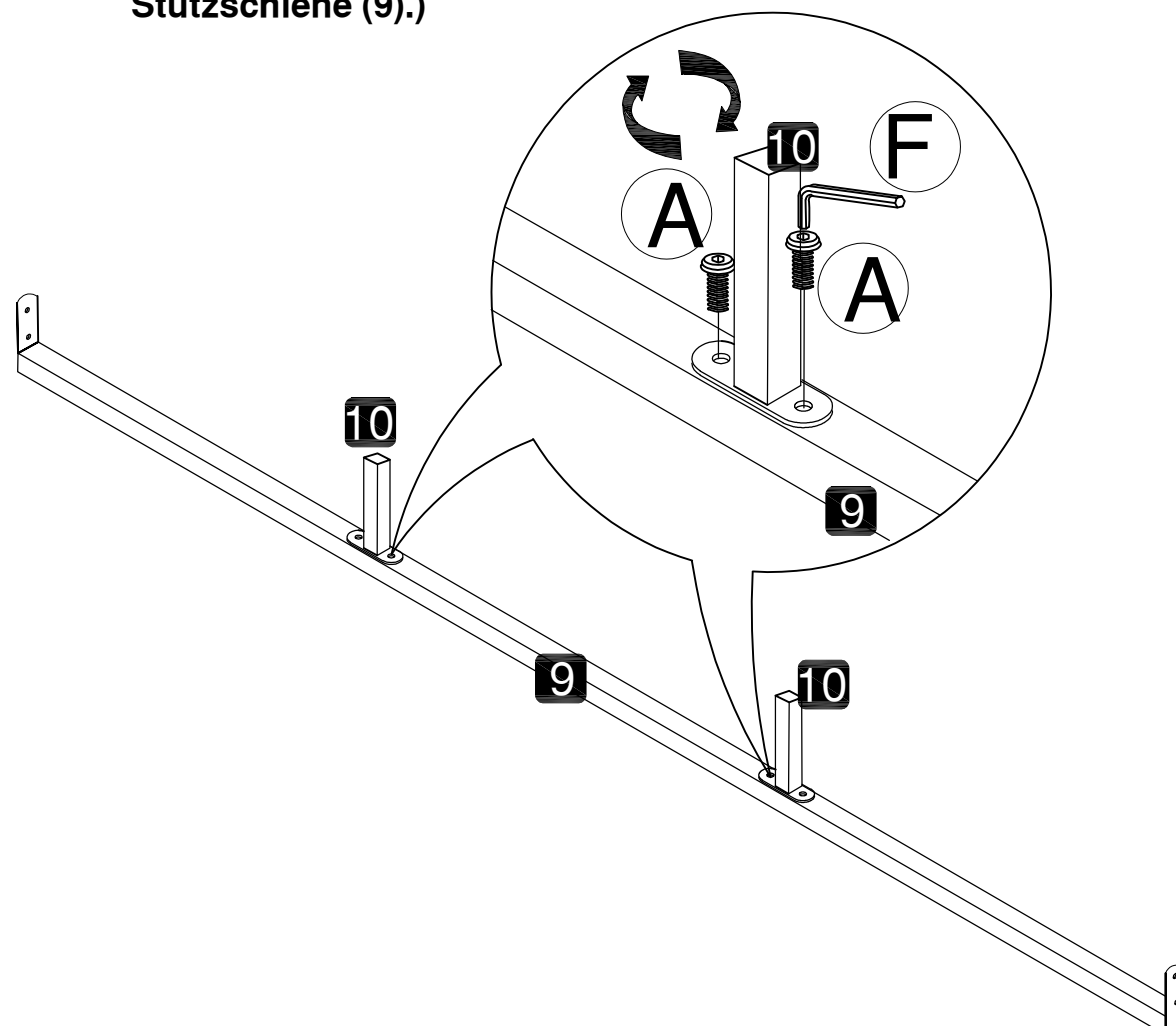

Step 5

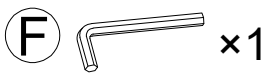
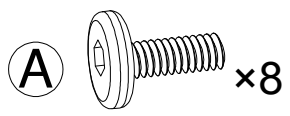

Use the hexagonal wrench (F) and bolt (A) to fix the assembled side member (3) to the headboard support leg (5) and pedal (2).

(Verwenden Sie den Sechskantschlüssel (F) und den Bolzen (A), um das montierte Seitenteil (3) am Kopfteil Stützbein (5) und Pedal (2) zu befestigen.)

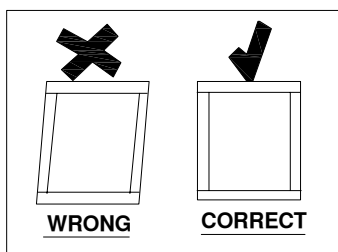
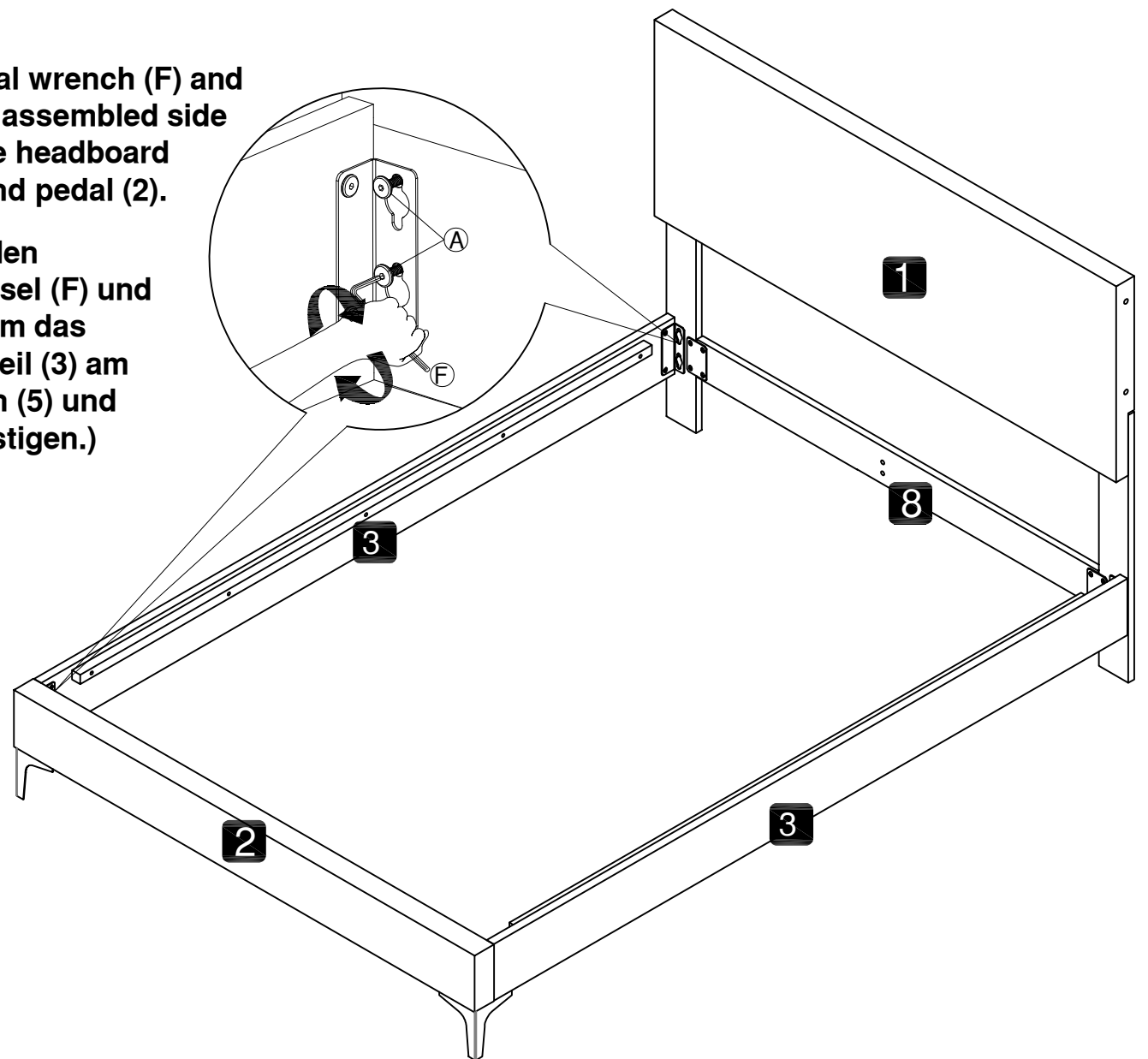

Step 6

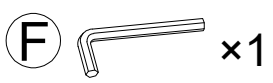
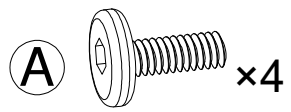

Use the hexagonal wrench (F) and bolt (A) to fix the central support rod (9) to the head board leg Connecting plate (8) and pedal (2).

(Verwenden Sie den Sechskantschlüssel (F) und den Bolzen (A), um die zentrale Stützstange (9) am Kopfbrettbein zu befestigen Anschlussplatte (8) und Pedal (2).)

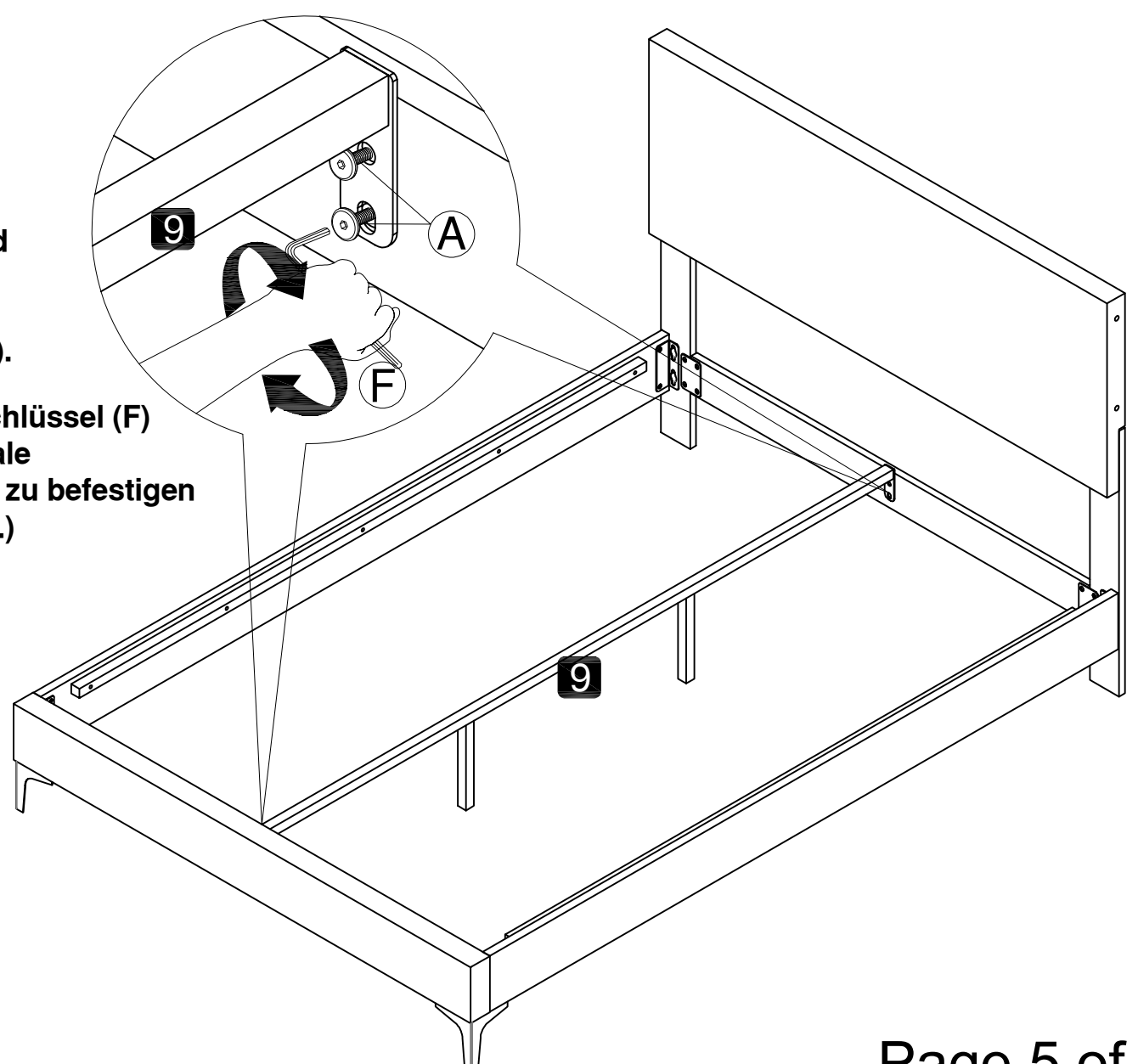

Step 7

Paste slats (4) onto side rails.

(Lamellen (4) auf Seitenschiene kleben.)

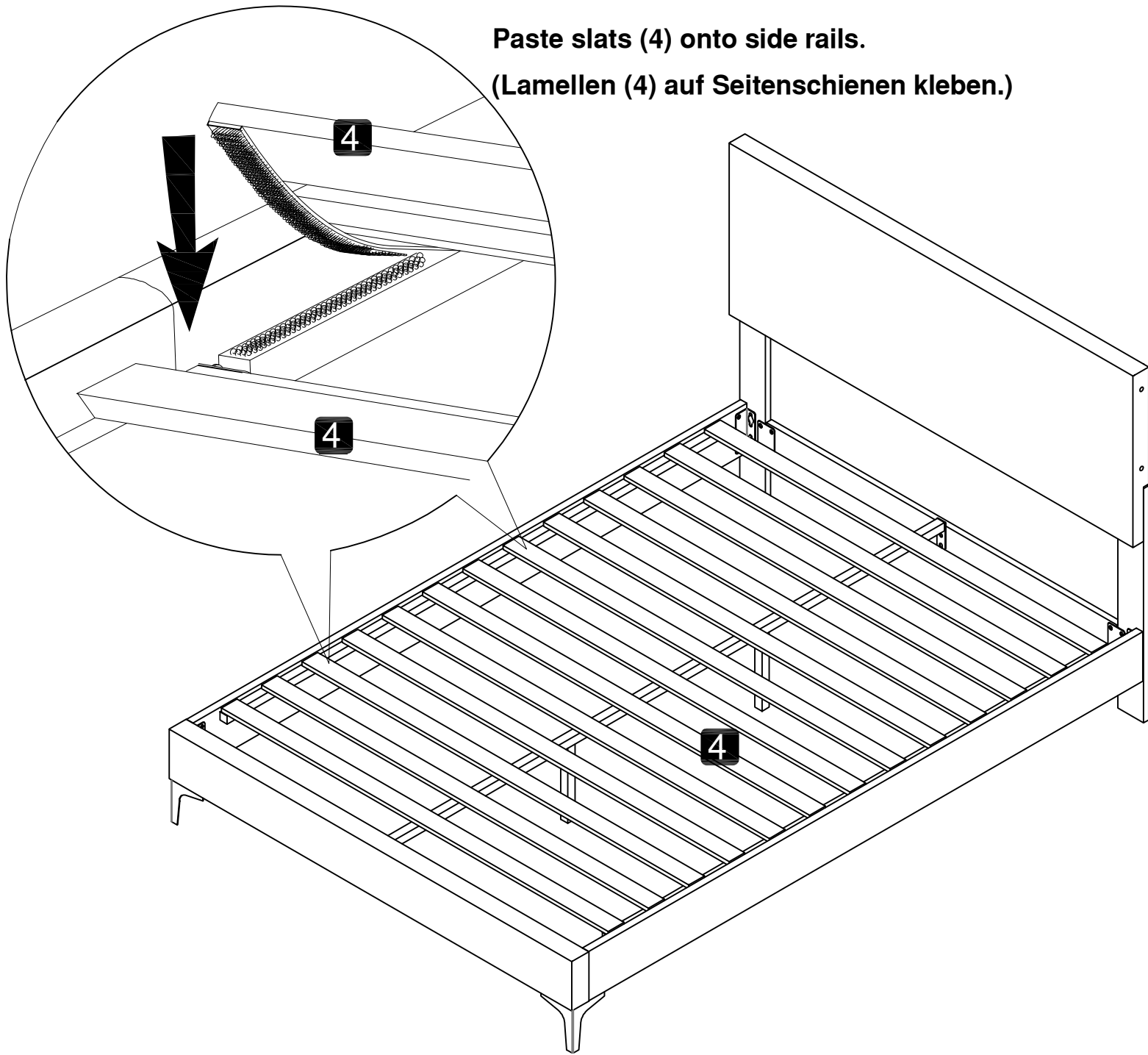

Step 8

B  x4

D  x8

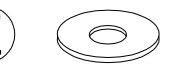
E  x4

F  x1

Fix the wing plates (6L) and (6R) to the headboard (1) with an Allen wrench (F), bolts (B) and flat washers (E).

(Befestige den Flügel (6L)&(6R) mit einem Inbusschlüssel (F) und Schrauben (B)&Flachscheiben (E) am Kopfteil (1).)

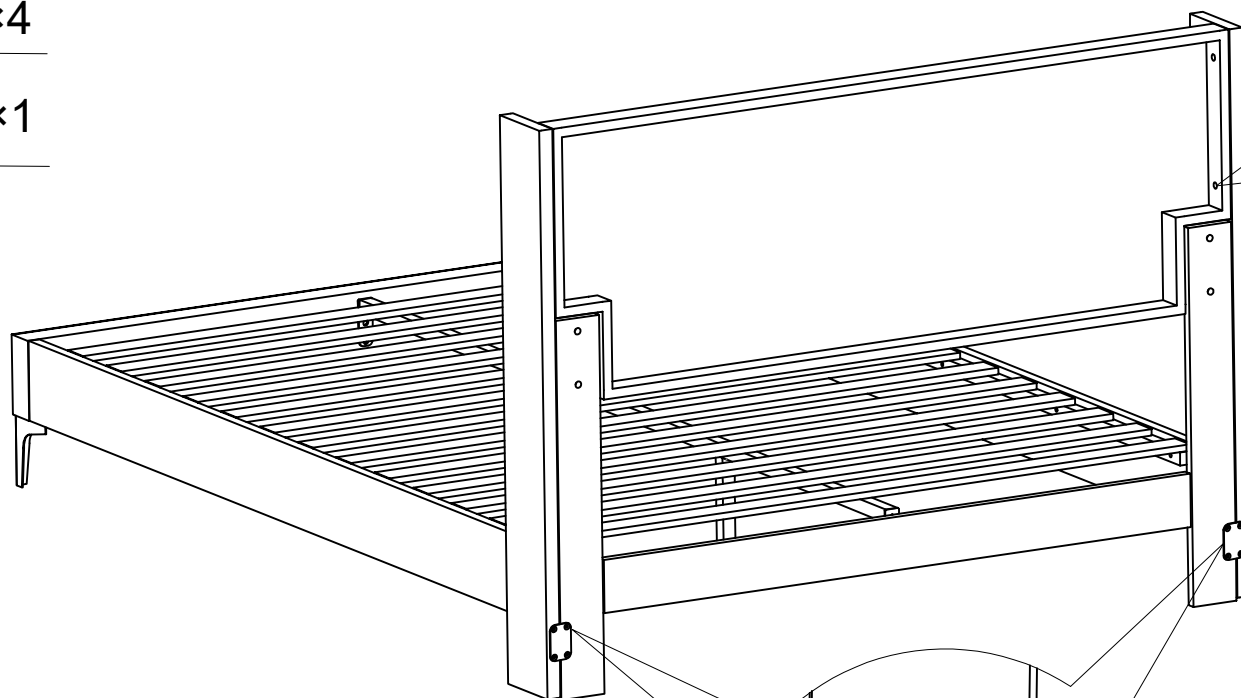
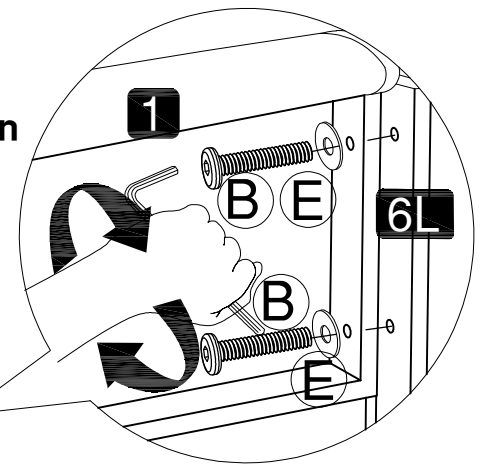

Fix the reinforcing plate (11) to the bedside outrigger (6) with screws (D).

(Befestigen Sie die Verstärkungsplatte (11) mit Schrauben (D) am Bettstütze (6).)

